

Chapter 1: SYSTEM DESCRIPTION

SCOPE

This document describes the functional specifications for the Compal NoteBook personal computer ACY25 series. The system is hardware and software compatible with the IBM PC/AT personal computer.

SYSTEM

- Intel Mobile P4 1.4G/1.5G/1.6G/1.7G/1.8G/1.9G/2.0GHz (μ FCPGA CPU)
- SIS650(SIS315 VGA embedded)
- SB SIS961 for system controller, PCI controller, LPC, AC_link interface, IDE controller & USB interface.
- SMSC LPC47N227 for FDC, one Serial ports and one Parallel port
- NS87591 for Keyboard Controller, Keyboard Scanner and Battery management Unit
- ENE CB1420 for Card Bus PCMCIA controller.
- Realtech ALC202A for AC97 codec
- Realtech 8100BL for On Board LAN controller

Memory

- Two 200-pin +2.5V DDR SO-DIMM connector, supporting PC1600/PC2100 DDR SDRAM memory card. Maximum upgradable to 1GMB by two 512MB DDR SO-DIMM modules. 128MB, 256MB, 512MB DDR SDRAM RAM module.
- 512KB L2 Cache on CPU

BIOS

- 512KB Flash ROM for system and Keyboard BIOS (Bootblock)
 - a) Suspend to Disk
 - b) Password protection for System and HDD
 - c) PC99 and windows WinXP/W2K ready with PnP
 - d) ACPI compliant BIOS
 - e) Support windowXP
 - f) Various hot key for system control

Power

- The charging time from empty to full capacity 3hrs typical (system off), 6.0hrs typical (system on) at room temperature. based on system loading.
- More than 300 charging / discharging cycles.
- 2.5hr battery mark operation time with PMU disable, ACPI enabled and backlight adjusted to 3/7 Maximum brightness.
- 8-cell Li-Ion of 18650 size battery pack with 57.7wh capacity

One 2.5" (9.5mm) up to 40GB Hard Disk

- Bus Master IDE
- Removable
- Support Ultra 100 synchronous DMA(ATA-100)

LAN on board 3COM Realtech 8100BL

Options

- Removable 2.5" IDE HDD, upto 40GB
- Removable Module : CD-ROM, DVD, CDRW, CDRW/DVD COMBO.
- MINI-PCI AC-Link soft modem
- 128MB/256MB/512MB PC1600/PC2100 DDR SO-DIMM modules
- Lilon Main Battery Pack

Touch Pad with two buttons(Standards Compliance)

- ACPI compliance
- Win XP and W2K hardware compliance

I/O Ports

- One 25 pins Parallel port, EPP/ECP Capability
- One 15 pins CRT port
- One 6 pins external PS2/AT full keyboard connector
- One Audio Microphone in, Line out port (with Digital volume control)
- Build in Microphone
- One 3 pins AC Adapter Jack
- One type III/Two type II PCMCIA Card Bus slots
- Three 4 pins USB port
- One RJ11/RJ45 for modem and LAN

PCMCIA Controller

- PC card 95 supported with one type III/two type II card sockets
- SRAM, OTPROM, FLASH ROM, mask ROM memory card up to 64MB
- MODEM/LAN card
- 32bit PCI bus
- Card bus card

Excellent Power Management Function

- Standby mode or Hibernation mode, by time out or by hot key
- Speedstep option
- HDD Local Stand-By mode by time out
- LCD Local Stand-By mode by time out
- Low battery alarm by beep and system window (power state indication using the 2 LED on the palm rest add detail here)
- System status indicators
 - a) LED system window by 3 LED's for Num Lock, Caps Lock, Scroll Lock display
 - b) 4 LED'S indicators
 - 1) POWER: System Active - LED is solid green
Suspend - LED is solid amber
 - 2) IDE : Action - LED flashes green as accessed
 - 3) BATTERY: Charging - LED is blinking green per four seconds
Fully charged - LED is solid green
Discharging - LED is off
Low batt. (10%) - LED is sold amber;
Critical low (5%) - LED is fast blinking amber per second
system beeps when critical low first reached.
 - 4) Wireless: LED is solid green
- Auto-backlight off when LCD cover closed
- ACPI 1.0B supported

Switch

- Power switch
- LCD Lid switch
- Internet switch
- Wireless ON/OFF switch
- E-mail switch

AC Adapter

- Universal AC adapter module. 90-265V_{AC}, 47-63HZ, 70W.

Security

- Boot-up password protection
- Single level password architecture. (Supervisor)
- HDD Password

Memory Card & DDR SO-DIMM Socket

- 128MB, 256MB, 512MB +2.5V PC1600/PC2100 200-Pin DDR SO-DIMM Memory Card Ready.

Electrical specifications

Mother Board

Microprocessor

- Intel μ FCPGA
- Design for Mobile, Northwood, PENTIUM 4
- Level 2 Cache controller supported
- Level 1 Write-Back Cache supported

System Logic

- SIS
- Host Bridge/ controller processor host Bus support
- Integrated DRAM controller
- VB BUS Interface
- Power management Functions
- Hyber Link Interface

Memory

- System SDRAM
128MB,256MB,512MB PC1600 /PC2100 DDR SO-DIMM memory modules upgradable to 1GMB extended memory maximum
- System + EC ROM BIOS
512KB Flash ROM

Fixed Disk Interface

- PCI IDE supported
- ATA-5 supported
- PIO MODE 4 Timing supported
- Ultra 100 synchronous DMA mode supported

Video Subsystem

- Graphics Controller embedded in NB SIS650
- 256 bit graphics core
- Texture mapped 3D with point sampled, Bilinear, Trilinear, and Anisotropic filtering
- Hardware setup with support for strips and fans
- Hardware motion compensation assist for software MPEG/DVD decode
- PC 99 and PC 2001 Compliant

Super I/O Controller

- SMSC LPC47N227
- Outstanding Features
- LPC bus interface, based on Intel's LPC Interface Specification Revision 1.01, February 1999 (supports CLKRUN and LPCPD signals)
- PC99 and ACPI compliant
- Serial IRQ support (15 options)
- Interrupt Serializer (4 Parallel IRQs to Serial IRQ)
- Internal FDD signal support
- 5V tolerant and back-drive protected pins (except LPC bus pins)
- 100-pin TQFP Package

Keyboard Controller

- NS87591
- KBC standard interface
- Support three independent PS/2 devices (K/B, mouse and internal pointing device)
- Real Time Clock (RTC)
DS1287,MC146818 and PC87911 compatible
- Four on chip times
 - 16-bit programmable timer base counter with 5 bit prescaler
 - 8-bit WATCHDOG timer
 - 16-bit timer with 30-us resolution
 - 16-bit general purpose timer with PWM and Capture Capabilities
- Support AMP1.2
- Active mode operating frequency 4-10 MHz

ACPI CarBus Controller ENE CB1420

- ACPI-PCI Bus Power Management Interface specification Rev 1.1 Compliant
- Supports OnNow LAN wakeup, OnNow Ring Indicate, PCI CLKRUN#, and PME#, AND CardBus CCLKRUN#
- Compliant with PCI specification v2.2, PC Card Standard 7.0 and JEIDA 4.1
- Yenta™ PCI to PCMCIA CardBus Bridge register compatible
- ExCA (Exchangeable Card Architecture) compatible registers mappable in memory and I/O space
- Intel™ 82365SL PCIC Register Compatible
- Supports PCMCIA_ATA Specification
- Supports 5V/3.3V PC Cards and 3.3V CardBus cards
- Supports single PC Card or CarBus slot with hot insertion and removal
- Supports multiple FIFOs for PCI/CardBus data transfer
- Supports Direct Memory Access for PC/PCI and PCI/Way on PC Card socket
- Programmable interrupt protocol: PCI, PCI+ISA, PCI/Way or PC/PCI interrupt signaling modes
- Win'98 IRQ and PC-98/99 compliant
- D3_{cold} state PME# wakeup support
- 3.3Vaux Power Support
- Integrated PC 98-Subsystem Vendor ID support, with auto lock bit

Floppy Disk Drive

- 3.5"1.44MB, 3 mode as an I/O module

Hard Disk Drive

- 2.5" up to 40 GB, 9.5mm height

CD-ROM Module

- 12.7mm height module
- CD-ROM, DVD, CDRW,COMBO
- 24X CD_ROM

Audio Port

MIC IN

- AC-coupled input,100mVP-P maximum

Line out

- 1V_{P-P}

Built-in Microphone

- Sensitivity-45dB
- S/N:58dB

Built-in Speakers

- 8Ω, 1W (resonant frequency 460HZ) speakerX2

Built-in Speakers

- 8Ω, 1W (resonant frequency 460HZ) speakerX2

Display Device

- COLOR TFT/XGA LCD (CPT CLAA141XF01)
Dimensions : 298.5 (W) X 227.5 (H) X 5.5 (D) mm (max)
Active area : 285.7(W) X 214.3(H) mm, 14.1"
1024 X 768 XGA Resolution
Response time: 30 (max)
Contrast ratio 200:1 (Typ)
Brightness 150 Nit (Typ)
- COLOR TFT/XGA LCD (AU B150XN01)
Dimensions : 315.8 (W) X 240.5 (H) X 6.5 (D)mm (max)
Active area : 304.1(W) X 228.1(H)mm, 15"
1024 X 768 XGA Resolution
Response time: 40ms(max)
Contrast ratio 250:1 (Typ)
Brightness 200 Nit (Typ)
- COLOR TFT/XGA LCD (LG LP150X04)
Dimensions : 315.8(W) X 240.5 (H) X 6.8(D)mm (max)
Active area : 304.1(W)X228.1(H)mm,15.0"
1024 X 768 XGA Resolution
Response time: 30ms(max)
Contrast ratio 250:1 (Typ)
Brightness 200 Nit (Typ)
- COLOR TFT/SXGA+ LCD (IBM ITSX95C)
Dimensions : 317.3 (W) X 242. (H) X 6.3 (D) mm (max)
Active area : 304.5(W) X 228.3(H) mm, 15.0"
1400 X 1050 SXGA Resolution
Response time: 60 (max)
Contrast ratio 200:1 (Typ)
Brightness 140 Nit (Typ)
- COLOR TFT/SXGA+ LCD (LG LP150E01-A2M2)
Dimensions : 317.3(W) X 241.5(H) X 6.6 (D) mm (max)
Active area : 304.5(W) X 228.375(H) mm, 15"
1400 X 1050 SXGA+ Resolution
Response time: 50 (max)
Contrast ratio 200:1 (Typ)
Brightness 180 Nit (Typ)
- COLOR TFT/XGA LCD (AU UB141X03)
Dimensions : 298.5(W) X 226.7(H) X 5.5 (D) mm (max)
Active area : 285.696(W) X 214.272(H) mm, 14.1"
1024 X 768 XGA Resolution
Response time: 50 (max)
Contrast ratio 250:1 (Typ)
Brightness 150 Nit (Typ)
- COLOR TFT/XGA LCD (Hitachi TX38D85VC1CAB)
Dimensions : 315.5(W) X 240.5(H) X 6.8 (D) mm (max)
Active area : 304.1(W) X 228.1(H) mm, 15"
1024 X 768 XGA Resolution
Response time: 60 (max)
Contrast ratio 100:1 (Typ)
Brightness 150 Nit (Typ)
- COLOR TFT/SXGA+ LCD (CPT CLAA150PA01)
Dimensions : 317.3(W) X 242(H) X 6.8 (D) mm (max)
Active area : 304.1(W) X 228.1(H) mm, 15"
1400 X 1050 SXGA+ Resolution
Response time: 40ms (max)
Contrast ratio 200:1 (Typ)
Brightness 150 Nit (Typ)

Keyboard

- 86 /90 keys with 101/102 key emulation
- 3.0±0.15mm full stroke keys, operating force 60±10g
- Phantom key auto detect
- Overlay numeric keypad
- Support independent pgdn/pgup/home/end keys
- Support reverse T cursor keys
- Factory-configurable different languages by OEM customer
- Window key supported

Mechanical Specification

- FOR 14.1"
12.7"(W)x10.8"(D)x1.5"(H)[322.0mm(W)x274mm(D)x38.0mm(H)]
6.7lb~7.2lb(including: HDD, CD-ROM, FDD and BATT module)
- FOR 15.0"
12.9"(W)x10.8"(D)x1.5"(H)[327mm(W)x274mm(D)x38.5mm(H)]
6.78lb~7.5lb(including: HDD, CD-ROM, FDD and BATT module)

Option Pack:

- AC adapter : 444g
- HDD Pack : 160g(9.5mm)
- BATT (Li-ion) : 414g(8cell)
- CD-ROM module : 259g
- FDD module : 202g
- Memory card reader module

Mechanical Function

- Removable HDD.
- Module (CD-ROM , BATT , DVD , FDD)
- Battery changeable (Li-ion).
- For security can use Kensington Lock.
- Scissor type key board standard pitch 3.0 m/m travel length.
- PCMCIA sockets supported with one type II cards.

Mechanical Material

- Plastic PC+ABS(Bayer, FR2000)

Environment Specification

Operating

Temperature	+5°C to +35°C
Relative Humidity	10% to 90% without condensation
Altitude	sea level to 10000FL

Storage or Shipment

Temperature	-20°C to +50°C
Relative Humidity	10% to 90% without condensation
Altitude	sea level to 40,000ft

Chapter 2: Software Specification For System BIOS

System Component Summary

Platform	CY25
Processor	Intel® Mobile P4 uFCBGA/uFCPGA
FSB	400MHz
Core Logic	<ul style="list-style-type: none"> - SIS 650 + SIS961(SB) - PC 133 compliant - Integrated VGA - SpeedStep support - IMVP support - DDR 266 support
System Memory	<ul style="list-style-type: none"> - PC1600/PC2100 DDR SDRAM memory interface design - 0MB DDR RAM on board - Two DDR SODIMM (200-pin/2.5V/1.25V) connectors - Maximum memory up to 1GB with two 512MB SODIMM - One on Bottom/RAM Door, easily removable to allow easy upgrade
System ROM	512KB flash BIOS ROM
Video Chip	<ul style="list-style-type: none"> - Integrated VGA chip in SiS650 North Bridge - SMA (Shared Memory Architecture) - 16MB VGA memory default setting, up to 64MB
Display	<ul style="list-style-type: none"> - 1024 x 768 XGA TFT color LCD, display area 14" - 1024 x 768 XGA TFT color LCD, display area 15" - 1400 x 1050 SXGA+ TFT color LCD, display area 15"
PCMCIA	<ul style="list-style-type: none"> - ENE CB1420 CardBus controller - PC card 95 supported with two Type II or one Type III - PCI Card Bus - No ZV(Zoom Video) support
Audio Controller	<ul style="list-style-type: none"> - Integrated Software Audio in SiS961 South Bridge with Realtek ALC202A AC97 Codec (No SPDIF) - Internal microphone
Super I/O Controller	SMC LPC47N227
Keyboard Controller	NS PC87591 K/B Controller
Pointing Device	- ALPS Touch pad with two buttons, scroll up/down buttons.
Keyboard	<ul style="list-style-type: none"> - Support Windows key, Application key - 19 mm pitch, 3.0 mm travel length - Full size keyboard with localization, key layouts for US, Europe and Japan required - Spill-proof
HDD	<ul style="list-style-type: none"> - 9.5mm height, 2.5" HDD - Easily removable (Configurable) - PCI Bus Master Enhanced IDE - Support Ultra DMA-66/100
FDD	<ul style="list-style-type: none"> - Internal standard square type FDD drive, - 12.7mm, - 1.44MB, 3 mode support
Module Bay	<ul style="list-style-type: none"> - 12.7mm, 24X CD-ROM drive, easily configurable design - 12.7mm, 8X CD-RW drive (Manufacture option) - 12.7mm, 8X DVD-ROM drive (Manufacture option) - 12.7mm, 8X DVD/CDRW COMBO (Manufacture option)
Power	70W universal AC adapter, 90-264V AC, 47-63Hz

Status	<ul style="list-style-type: none"> - Power status LEDs (Green/Amber) - Caps/Num/Scroll lock LEDs - HDD activity LEDs (Green) - Battery status/charging LED 	
Controls	<ul style="list-style-type: none"> - Power button, - Lid switch, - 2 user-programmable one-touch buttons, 	<ul style="list-style-type: none"> - Touch pad Left/Right - Scroll up/down button,
I/O Ports	<ul style="list-style-type: none"> - Parallel port, - VGA port, - PS/2 port, - Microphone-in jack, - Headphone out jack, - Serial port - Three USB ports, - S-Video 	<ul style="list-style-type: none"> - DC-in jack, - MODEM port w/ RJ-11 connector - LAN port w/RJ- 45 connector - Two branded audio speakers, - Internal microphone, - Composite TV-out, - One Mini-PCI socket
LAN	<ul style="list-style-type: none"> - Realtek 8100 on board LAN 	
Mini-PCI	<ul style="list-style-type: none"> - Option 1: Modem only - AC Link software Modem - Option 2: Combo - AC Link software Modem + Intersil 802.11b - Option 3: No Modem - TBD 	
1394	<ul style="list-style-type: none"> - VIA chipset: VT6306 (Option) - PCI single chip solution, PCI 2.2 compliant. - OHCI v1.1 - IEEE1394.A 	

System Controls

Hot Keys

All Fn Key will support Sticky key mode.

<i>Fn+ F5</i>	<i>Force Switching Display Mode(LCD->CRT->Simulataneous)</i>
<i>Fn + F10</i>	<i>Cursor keypad on/off. Pressing this hot key can enable/disable the embedded cursor keypad. Numeric lock state is logically disable.</i>
<i>Fn + F11</i>	<i>Num keypad on/off Pressing this hot key can enable/disable the embedded Numeric keypad. Numeric lock state is logically enable.</i>
<i>Fn + F12</i>	<i>Scroll Lock on/off</i>
<i>Fn + ↑</i>	<i>Increase Brightness (total 10 levels)</i>
<i>Fn + ↓</i>	<i>Decrease Brightness (total 10 levels)</i>

- After rebooting, pad lock is set to off and Num lock is set to on. In this state, the embedded cursor/number pad is not enabled on the notebook keyboard.

Note: Hot keys for brightness/contrast/Volumn up/down adjustment are in repeat mode, others will only be updated once for each key depression.

When the embedded cursor/number pad is on, holding down Fn will turn the embedded cursor/number pad off.

Buttons

Power Button

Under ACPI, the power button action is under the control of the operation system.

- The following is a table of the state transitions in ACPI mode.

Initial	Final	Comments
Off	On	Does a normal reboot. Prompts for password if required.
Standby	On	Restores device states from RAM. Prompts for password if required.
Hibernate	On	Restores RAM and device states from disk. Prompts for password if required.
On	Standby, Hibernate(default) or Off	. Action depends on OS setting. Can be set to Standby, Hibernate, or Off(default). . Note that the Off option is done under the control of the OS, so it is functionally the same as doing a Start-Shut down but probably quicker.

Power Button Over-ride

Holding down the Power Button for 4 seconds will cause an unconditional transfer to the Off state without notifying the operating system.

If press power button for less than 4 seconds, the system will enter suspend to RAM or OFF state according to OS UI setting.

Lid Switch

This section describes the expected behavior of the system when the lid is opened or closed by the user.

If the system is running under legacy mode:

- Closing the lid will turn off LCD backlight.

If the system is running under ACPI mode:

- The function of lid switch will follow the OS setting in power management (Nothing, standby, Hibernate or Power off). If standby, the system wakes up when the lid opens. If nothing, the backlight must still turn off when the lid is closed.

System status indicators

Please refer to Keyboard BIOS specification.

Core BIOS Features

Enhanced IDE Disk Drive Support (EDD)

In addition to AT standard disk drive support, the Phoenix NoteBIOS 4.06 also supports:

- Auto-detection and sizing of all IDE drives.
- Logical Block Addressing(LBA)
- Fast DMA support
- Ultra DMA-33/66/100 support

The CHS translation mode will be used.

Multi Boot

The notebook can support Multi Boot for selecting the boot sequence of hard disk, floppy, CD ROM, Network Boot in Setup. It identifies all IPL (Initial Program Load) devices in the system and attempts to boot them in the order specified in Setup.

Quiet Boot

Quiet Boot replaces the customary technical messages during POST with a more visually pleasing and comfortable display (OEM Logo screen). During POST, right after the initialization of VGA, The notebook displays an illustration called the OEM screen during system boot instead of the traditional POST screen that displays the normal diagnostic messages.

The OEM Logo screen stays up until just before the operating system loads unless:

- Press <Esc> to change the boot order.
- Press <F2> to enter Setup. (When pressed, need to show "Entering Setup...")
- Press <F12> to boot from LAN (When pressed, need to show "Booting from LAN...")
- Whenever POST detects a non-terminal error, it switches to the POST screen near the end of POST, just prior to prompting for a password.
- If the BIOS or an option ROM requests keyboard input, the system switches over to the POST screen with prompts for entering the information. POST continues from there with the regular POST screen.

New Interrupt 15h extensions

The BIOS must support the recently defined standard INT 15 extensions:

Big Memory

Big memory support that can reporting greater than 64 megabytes of RAM. The notebook supports the INT 15h big-memory reporting functions of E801h, E881h, and E820h. This feature reports all available extended memory (both below and above the 64MB limit) using both a real mode (E801h) and a 32-bit protected mode (E881h) interface. Operating systems can access the real-mode interface through the standard INT 15h call. They can access the protected-mode interface through a 32-bit interrupt call, much like the EISA protected-mode interface. The Microsoft-defined E820h function returns a complete memory map through a series of repeated calls.

Boot Block

The Flash ROM used in many systems today offer the customer the advantage of electronically reprogramming the BIOS without physically replacing the BIOS ROM. This advantage, however, does create a possible hazard: power failures or fluctuations that occur during updating the Flash ROM can damage the BIOS code, making the system unbootable. To prevent this possible hazard, many Flash ROM include a special non-volatile region that can never be erased. This region, called the boot block, contains a fail-safe recovery routine. If the boot block finds corrupted BIOS, it prompts the end user to insert a diskette, from which it loads several files that replace the corrupted BIOS on the Flash ROM with an uncorrupted one.

Plug-n-Play (PnP) Support

To achieve the goal of PnP, a POST conflict detection and resolution (CDR) module, and a run-time services module will be integrated into the system BIOS.

The PnP runtime service module includes multiple interfaces so that the system can support the current DOS/Win3.1 non-PnP drivers, as well as Win95 operating system that include specific support for the PnP BIOS specification.

Security Features

Security features to be supported are passwords, electronic serial number, PC identification string.

The Electronic Serial Number provides a unique way of identifying an individual notebook.

PC Identification strings allow the user or administrator to personalize the notebook for asset tracking or identification if it is lost.

The Passwords, Serial Number, and PC Identification strings are to be stored in EEPROM.

2 Level Passwords

The notebook supports two levels of password protection. The password support consists of a User Password and an Administrator Password. They each contain up to eight characters, and are stored in EEPROM. Using the administration password to enter the setup utility allows the user to access all the configurable fields. Whereas using the user password only allows the user to configure a limited number of fields.

When the password is enabled, the notebook may display a suitable password prompt on the main display in the following situations:

- Turning on from off states. (No BIOS suspend/resume password)
- Entering to Setup.

The User will attempt to enter a password, then press ENTER. If the User fails to enter the password in three tries the system will be halt.

User Password

The user can choose:

- The password will never be required
- Be required to boot.
- The user password may not be set unless the administrator password is set. If the user wishes to only have one password then the administrator password is used.

Administrator Password

There are three primary uses for the Administrator Password:

- Protect users from changing system configuration that could cause the notebook to malfunction.
- As the users password if only a single password is desired.

Passwords and Setup

There are individual checkbox items in Setup to allow the user to specify when to require a password. The wording of these options should be:

Password Required to:

Boot [Enabled]

The following table lists the items in the Setup utility which can be modified by the User.

Time & Date

User password

While setting new password, three failures to enter the old password will result in the system turning off.

Valid Password Characters

Valid Password Characters

- The numbers 0 to 9.
- The letters A to Z (not case sensitive).

The password is stored as scan codes.

Electronic Serial Number

The electronic serial number is a ten (10) byte string which matches the manufacturing serial number on the bottom of the notebook. The BIOS must display the electronic serial number in the boot screen and in Setup. The format of the line should be

Serial Number: SSSSSSSSSS

where SSSSSSSSSS is the electronic serial number. The format of the serial number is:

CCYWWNNNNN

Where

CC is a two character country code (TW for Taiwan).

Y is the year of manufacture (7 = 1997, 8 = 1998, etc.)

WW is the week of manufacture (1 to 52)

NNNNN is the unit number (see below).

Unit number is a number from 00000 to 99999 and is incremented for each unit produced.

The unit number is reset at the beginning of each week. Before displaying the serial number, the BIOS must check for the special 'invalid' serial number (INVALID000). If this special serial number is detected, the BIOS should display the message:

INVALID ELECTRONIC SERIAL NUMBER

ENTER THE SERIAL NUMBER NOW:

The BIOS must then force the user to enter the serial number and program the entered serial number into the EEPROM. The BIOS must perform validity checks on the serial number entered.

System boards sent to service must be preprogrammed with this invalid serial number. This is to insure that when a service technician swaps a new main board into a system that he/she sets the serial number to match the serial number of the system.

This same electronic serial number is used for the serial number returned by the SM BIOS.

Software Password Backdoor

Because users occasionally forget their password we need a method of removing the password for them. This method must involve little risk to the security of the password system in general.

The method is that the User calls up Customer Support, Support tells them to press some *special key combination which causes a 'secret code' to be displayed, the user describes this to support representative who then use their secret decoder ring to generate a 'super-password' which they tell the user to type in. This removes (deletes) all passwords (user and administrator).

During the password request process, three failed attempts to enter the backdoor password will also cause system turning off.

The back door password process can only be held on the cold boot.

Thermal management

There are two types of cooling techniques used for thermal management. The first type is passive cooling where the CPU speed is reduced or other devices power consumption is

reduced in an effort to reduce heat generation. The second type is active cooling where a fan is turned on to cool the system.

In non-ACPI mode(Legacy Mode), the thermal management is achieved by controlling the fan depend on the temperature. Besides turning the fan on and off. The system may also be shut off whenever the temperature can't be reduced even the fan are spinning in the full speed. The system will be turned off immediately when it's over-heating (over 85°C). The fan will be turned off when temperature is under 65°C. The table below listed the control point of temperature changes:

Temperature	Fan Off	Fan on(100%)	System Off
< 62°C	X		
65°C		X	
> 85°C			X

Power Management

Introduction

The notebook supports ACPI power management modes. The system will dynamically switch to ACPI mode for configuration and power management when an ACPI OS is loaded.

System Time-outs

The system Time-outs include the Standby time-out, the Suspend time-out, and the Hibernate time-out.

System Time-outs are handled by the operating system in ACPI mode. BIOS time-outs must be disabled. System time-outs are set using the control panel power applet.

System Power Management

The overall system can be in one of five system power states as described below:

Legacy Mode	ACPI mode	Power Management
Off	Mech. Off (G3)	All devices in the system are turned off completely.
	Soft Off (G2/S5)	OS initiated shutdown. All devices in the system are turned off completely.
On	Working (G0/S0)	Individual devices such as the CPU and hard disk may be power managed in this state.
	Standby (S1)	CPU in Stop Clock state VGA Standby, turn off backlite PCMCIA Standby Audio Power Down Hard Disk Spin Down motor Super I/O Low Power Mode
	Suspend to RAM (S3)	CPU set power down VGA Suspend PCMCIA Suspend Audio Power Down Hard Disk Power Down CD-ROM Power Down Super I/O Low Power mode
	Save to Disk (S4)	Also called Hibernate state. System Saves all system states and data onto disk prior to power off the whole system.

Device Power Management

The device specific power management supported by this notebook includes the CPU and the hard disk.

CPU power management

- ACPI mode

The operating system detects when the system is idle and places the CPU in one of the 3 CPU low power states (C1, C2 or C3) depending on how much latency it believes the system can afford.

The C1 state is simply the CPU halt instruction. The C2 state is the CPU stop grant state. The C3 state is the CPU stop clock state. The CPU stays in this state until an interrupt occurs.

Hard Disk

- ACPI mode

Newer OSes use the spin down timer of the hard drive to set time-outs. The user can set the hard disk spin down time-out in the control panel power applet.

System Wake Up Sources

The table below lists the wake up events for all low power states:

Events	S1	S3	S4	Process required
Hot Key(*1)	-	-	-	-
Power button	V	V	V	-
Lid open	V	V	-	-
Lid close	-	-	-	-
Modem Ring (Mini-PCI Modem)	V	V	-	-
Modem Ring (USB/PCMCIA Modem)	-	-	-	-
Modem Ring (Serial Port Modem)	-	-	-	-
LAN (Mini-PCI NIC)	V	V	-	-
LAN (USB/PCMCIA NIC)	-	-	-	-
AC/Battery	-	-	-	V
Thermal	-	-	-	V
RTC	V	V	-	-
COM/LPT/KB/Mouse/FDD/HDD	-	-	-	-
Audio/Video activity	-	-	-	-
PCMCIA	-	-	-	Driver
USB(*2)	-	-	-	Driver
Module swap---Battery	-	-	-	V
Module swap---non Battery	-	-	-	V
CRT(no event) plug/unplug	-	-	-	V
Hot Plug PS/2 devices	-	-	-	KB only

Critical low battery	-	-	-	-
----------------------	---	---	---	---

Field 'Process Required' identifies that further process for the occurred events must be processed during wake up or resume procedure.

*1: Hot keys are not wake up source of standby, suspend to RAM and Hibernate states.

*2: Activity of the USB device is dependent on the driver support.

Power Button

The power button will wake the system from any low power state as described in the Power Button section.

Real Time Clock Alarm

The Real Time Clock alarm interrupt will wake the system from standby, suspend.

Power Management – ACPI

Introductions

The Advanced Configuration and Power Interface (ACPI) is a well-specified power management and configuration mechanism. It evolves the existing collection of power management codes, APM, PnP BIOS, ..etc.

Power State Transition Diagram

The state transition diagram is identical to the one in APM mode.

Time-outs while On AC Power

OS determines the behavior of the feature.

Embedded controller

The keyboard controller will act as the ACPI embedded controller and support the ACPI EC protocol and interface.

SCI/SMI events

All ACPI OS controllable events will be triggered as SCI. Otherwise SMI will be triggered.

PC2001

The notebook must meet Microsoft Logo requirements in accordance with the PC2001 Design Guide and the Microsoft Logo test programs.

Miscellaneous Features

Single BIOS ROM

The system BIOS and Keyboard BIOS share one single flash ROM. The size of the flash ROM is 512KB.

USB Support

This feature allows the use of a USB keyboard to access BIOS Setup and to be used in DOS without additional drivers.

IDE interface

The IDE device supported master channel.

Flash utility – one BIOS ROM only

The flash utility can be used to program both system and keyboard BIOS at the same time.

EEPROM

There is one EEPROM which is used to store many important system and user data in the notebook. The size of the EEPROM is 2K bytes.

Password Protection

Password and Security support will be implemented in this model. See the PhoenixBIOS 4.0 User Manual for sample screen and the description of Password and Security support.

VGA Support

This section describes the expected behavior when a video monitor is connected to the VGA port on the notebook or port replicator.

The BIOS will use both of the RGB and pin 11 methods to determine the presence of an external VGA monitor. Either case meet will indicate an external VGA monitor is present.

The BIOS setup utility will have a menu for setting up the behavior of the external VGA port according to user preference. There are two settings:

Setting 1, AUTO: Auto-select External VGA if attached(CRT only), LCD if external not attached.

Setting 2, BOTH: Both External VGA and LCD always on.

When setting 1 is selected the BIOS will automatically turn the internal display off and the external monitor on, whenever an external monitor is detected. Otherwise it will enter LCD only mode (with the backlite off if the cover lid is closed). This means that the BIOS must check for the external video being present during POST; on resume from standby, on resume from suspend to RAM, on resume from hibernate; on warm dock, on hot dock, on hot undock, and on warm undock.

When setting 2 is selected, the BIOS will always turn on both the internal display and external monitor regardless of whether an external monitor is detected.

The hot key for switching the external video (Fn + F5) must only make a temporary change. It must not change the user's preference in CMOS, it will just change the current state of the external video port. Also the hot key must not check to see if an external monitor is detected before switching to external only mode. It should just toggle between internal only, both, and external only (without regard to monitor detect). The hot key setting will not survive suspend to RAM, hibernate. In these cases the mode should be set back to the setting stored in CMOS.

Internal Pointing Device Support

Added a new BIOS setup to enhance the PS/2 pointing devices

PS/2 Pointing Devices:

Auto-Selected: Disable internal pointing devices if external PS/2 mouse is present.

Simultaneous: The internal pointing device is always enabled. Any external pointing device connected will also be enabled at the same time.

- *If an external PS/2 mouse is detected, it will be enabled. If USB mice are detected, they will be enabled as well. If an external mouse contains a third mouse button, it will function as expected.*
- *Double click the Mouse icon in the Windows2000/XP Control Panel to adjust pointer speed, double click speed, right-handed versus left-handed button settings, and pointer appearance. The settings in this applet apply to all the external and internal pointing devices in the system. Except as described below, there are no individual pointing device adjustments available.*
- *Tapping (or double tapping) on the TouchPad is equivalent to a single (or double) left mouse click. The Synaptics TouchPad driver will be available on the hard drive and the*

customer may choose to manually install it. The Synaptics TouchPad driver should only be installed after first selecting Touch pad only in BIOS Setup.

- Hold down center button of external PS/2 mouse: While holding down the center button of an external mouse, move the mouse. This will cause the window to move. If the center button is not held down, all pointing devices function normally.
- Use TouchPad: The TouchPad is locked in as the Scrolling or Magnifying Glass device. Sweeping across the TouchPad causes the window to move. The other pointing devices function normally.

BIOS Version and Resource Allocated

BIOS version number

The BIOS version string is in below format:

pppp.x.yy

Where:

pppp Four letter platform descriptor.

x One digit BIOS major revision number.

yy Two digit BIOS minor revision number

Below lists the BIOS version numbers that will be assigned to this platform.

Platform	QA Releases	Production Release
CY25	CY25_0.xx	CY25_1.00

NOTE: yy starts at 0 and is incremented with each release of the specific type. During the development and testing of the second release the engineering and QA release will

Configuration Requirements

The table below lists the possible usage of the system resources:

IRQ	Hardware
00	System Timer
01	Keyboard
02	Programmable Interrupt Controller
03	Free by default or Generic
04	Communications Port (COM1)
05	PCI AUDIO/MODEM
06	Standard Floppy Disk Controller
07	ECP Printer Port (LPT1)
08	Real Time Clock
09	SCI
10	LAN / Universal Serial Bus
11	PCMCIA/VGA
12	Mouse
13	Numeric data processor
14	Primary IDE controller (hard disk)

15	Secondary IDE controller (CD ROM)
----	-----------------------------------

DMA	Hardware
00	PnP Audio System CODEC
01	Free
02	Standard Floppy Disk Controller
03	ECP Printer Port (default)

System Management BIOS(SM BIOS) version 2.3.1 or greater

This product require that SMB 2.3.1 BIOS sub-structures be supported as follows:

TYPE	Structure Type	Required?
0	BIOS Information	YES
1	System Information (Component ID)	YES
2	Motherboard Information	YES
3	System Enclosure	YES
4	Processor Information	YES
5	Memory Controller	YES
6	Memory Information	YES
7	Cache Information	YES
8	Port Connector Information	YES
9	System Slots	YES
10	On Board Devices	YES
11	OEM Strings	YES
12	System Configuration	YES
13	BIOS Language Information	NO
14	Group Associations	NO
15	System Event Log	NO
16	Physical Memory Array	YES
17	Memory Devices	YES
18	Memory Error Information	NO
19	Memory Array Mapped Address	YES
20	Memory Device Mapped Address	YES
21	Built-in Pointing Device	YES
22	Portable Battery	YES
23	System Reset	NO
24	Hardware Security	NO

25	System Power Control	NO
26	Voltage Probe	NO
27	Cooling Device	NO
28	Temperature Probe	NO
29	Electrical Curretn Probe	NO
30	Out-of-Band Remote Access	NO
32	BIOS Intergrity Service	YES
126	Inactive	NO
127	End-of-Table	YES

This product require that the Serial Number field, which is a string at offset 7 of the Type 1 (System Information) sub-structure, is to be filled in with the unit's Electronic Serial Number. This would be filled in at boot time. Please see section 5.4.2 for information on the Electronic Serial Number.

POST summary screen

The Post summary screen is a screen that appears at the end of the POST processing if quiet boot is disabled or the user presses the Esc key during POST. The screen must contain the information listing below:

- A copyright message
- Electronic Serial Number
- UUID number
- The BIOS revision number and model name in customer format

At the bottom of the screen, the screen should have the following messages:

Press ESC to change boot order

Press <F2> to enter setup, <F12> to boot from LAN

CMOS RAM management

The BIOS will automatically update certain information in CMOS on each boot. This information includes:

- DRAM size and configuration
- Hard disk configuration
- Always report the existence of one FDD.

If the CMOS RAM fails checksum or a power lost on CMOS battery is detected during boot, an appropriate error message will be displayed:

System CMOS checksum bad – Default configuration used

The system BIOS must automatically load default values defined in the setup menu during POST when encounter these problems. The user must not be required to take any action to continue the rest of POST(or entering SETUP).

Diskless Boot

This feature allows the system to boot off of a LAN when the hard disk is absent or has not been loaded with the operating system. It is utilized by the software download process in manufacturing. This product will use PXE since this is a PC2001 requirement.

System Setup

Invoking setup

The setup function can only be invoked by pressing F2 when " Press <F2> to enter Setup" message is prompted on the bottom of screen during POST.

The setup uses a menu driven interface to allow the user to configure their system. The features are divided into 6 parts as follows:

Main Allows the user to specify standard IBM PC AT system parameters.

System Devices Provides advanced settings of the system.

Security Provides security settings of the system.

Boot Allows the user to specify the boot options.

Info. Display the system informations.

Exit Allows the user to save CMOS setting and exit Setup.

During setup, all Fn function keys and power saving functions are disabled.

Setup screens

Main Menu

PhoenixBIOS Setup Utility			
<u>Main</u>	System Devices	Security	Boot Info. Exit
			Item specific Help
System Time:	[09:00:00]		
System Date:	[01/01/2002]		<Tab>, <Shift-Tab>, or
Floppy Disk Drive	1.44 MB		Floppy disk size
Internal Hard Disk:	[xxxxx MB]		Disk Size
ATAPI Device :	[Model Name]		
Boot Display Device:	[Both]		
Screen Expansion:	[Enabled]		
Television Type:	[NTSC]		Select NTSL or PAL standard
VGA Memory:	[32MB]		VGA Memory Size Configuration
F1 Help	↑↓ Select Item	F5/F6 Change Values	F9 Setup defaults
Esc Exit	←→ Select Menu	Enter Select	▶ Sub-Menu F10 Save and Exit

System Time and System Date

The hours is displayed with 24 hour format. The values set in these two fields take effect immediately.

Floppy Disk Drive

The Floppy Drive status is auto detected by system.

1.44MB, 3 ^{1/2} “	If there exists floppy drive.
Not installed	If there is no floppy drive.

Internal Hard Disk

The hard disk types and capacity are auto detected and set by the system. If there is no hard disk present or unknown type, "None" should be shown on this field, otherwise the capacity must be shown.

ATAPI Device

The CD-ROM, DVD-ROM or CD-RW are auto detected and set by the system. If there is no ATAPI Device present or unknown type, "None" should be shown on this field, otherwise the model name must be shown.

Boot Display Device

Both: Simultaneously enable both the integrated LCD screen and the system's external video port (for an external CRT or projector).

Auto-Selected: During power on process, the system will detect if any display device is connected on external video port. If any external display device is connected, the power on display will be in CRT (or projector) only mode. Otherwise it will be in LCD only mode.

Screen Expansion:

Enabled:

Disabled:

VGA Memory

VGA Memory size = 16/32/64 MB.

The default value is set to 32 MB.

Television Type:

NTSC: TV is NTSC standard

PAL: TV is PAL standard

Intel® SpeedStep™ Technology:

Automatic; / Maximum Performance / Battery Optimized / Reversed

NOTE: The sub-items under each device will not be shown if the device control is set to disable or auto. This is because the user is not allowed to control the settings in these cases.

System Devices

PhoenixBIOS Setup Utility	
Main	System Devices
	Security Boot Info. Exit
	Item specific Help
PS/2 Pointing Device	[Both]
Serial Port:	[Enabled]
Base I/O address	[3F8h]
Interrupt	[IRQ4]
Parallel Port:	[Enabled]
Mode:	[ECP]
Base I/O address:	[378h]
Interrupt	[IRQ7]
ECP DMA channel:	[DMA1]
Intel® SpeedStep™ Technology	[Automatic]
F1 Help ↑↓ Select Item F5/F6 Change Values F9 Setup defaults Esc Exit ←→ Select Menu Enter Select ▶ Sub-Menu F10 Save and Exit	

PS/2 Pointing Device

Configures the integrated internal pointing device using options:

Auto-Selected: If an external PS/2 mouse is connected to the system, then disable the internal pointing device. Otherwise enable the onboard pointing device. When an external PS/2 mouse is warm/hot plugged into the PS/2 mouse port, the internal pointing device will be disabled.

Both: The internal pointing device is always enabled. Any external pointing device connected will also be enabled at the same time.

Serial Port

Disabled/**Enabled**/Auto

Base I/O address

3F8h/2F8h/3E8h/2E8h

Interrupt

IRQ3/**IRQ4**

Parallel Port

Disabled/**Enabled**/Auto

Mode

Normal/Bi-directional/ECP/EPP

Base I/O address

378h/278h/3BCh

Interrupt

IRQ 5/IRQ 7

ECP DMA channel:

This field is hidden if **Mode** is not **ECP**

DMA 1/DMA 3

Security Menu

The following is Security menu if both of password is disabled, or enter Supervisor password when password is enabled:

PhoenixBIOS Setup Utility			
Main	System Devices	Security	Boot Info. Exit
			Item specific Help
User Password is		Clear	
Administrator Password is		Clear	
Set User Password		[Enter]	
Set Administrator Password		[Enter]	Supervisor Password controls access to the setup utility
Password Required to:			
Boot:		[Enabled]	
Processor Serial Number :		[Enabled]	
F1 Help ↑↓ Select Item F5/F6 Change Values F9 Setup defaults			
Esc Exit ←→ Select Menu Enter Select ▶ Sub-Menu F10 Save and Exit			

User Password is / Administrator Password is

These two fields shows that Administrator/User Passwords are set or not.

Set System Password is set.

Clear System Password is not set.

Set User Password / Set Administrator Password

Enter This field always shows the message.

While these fields are highlighted and press 'Enter', a window similar to the following is shown:

Set Administrator Password
Enter New Password []
Confirm New Password []

If there is an old password then setup will prompt with the following window instead and a current password will be required to be entered at first:

Set Administrator Password
Enter current password []
Enter New Password []
Confirm New Password []

User can now type password in field "Enter New Password", and re-enter password in field "Confirm New Password" for verification.

If the verification is OK:

Setup Notice
Changes have been saved.
[continue]

The password setting is complete after user presses enter.

If the current password entered does not match the actual current password:

Setup Warning
Invalid password
Re-enter Password
[continue]

If the new password and confirm new password strings do not match:

Setup Warning
Password do not match
Re-enter Password

The format of the password is as follows:

Length No more than 8 characters.

Characters 0-9, A-Z (not case sensitive)

Password Required to

Defines whether a password is required or not while the events defined in this group happened. The following sub-options are all requires the Administrator password for changes and should be grayed out if the user password was used to enter setup.

Boot

Allows the user to specify whether or not a password is required to boot.

Disabled/Enabled

Boot Menu

This menu allows the user to decide the order of boot devices to load the operating system. Bootable devices includes the diskette drive in module bay, the onboard hard disk drive and the CD-ROM in module bay.

PhoenixBIOS Setup Utility			
Main	System Devices	Security	Boot
1. Hard Disk		Item specific Help	
2. CD-ROM/DVD Drive		Use <↑> or <↓> to select a device,	
3. Floppy		then press <F6> to move it up the	
4. Network Boot		List, or <F5> to move it down the list.	
		Press <Esc> to escape the menu	
F1 Help	↑↓ Select Item	F5/F6 Change Values	F9 Setup defaults
Esc Exit	←→ Select Menu	Enter Select	▶ Sub-Menu F10 Save and Exit

Informations Menu

PhoenixBIOS Setup Utility					
Main	System Devices	Security	Boot	Info.	Exit
					Item specific Help
System BIOS Version:	CY25_1.00				
VGA BIOS Version:	SiS 1.07.xx				
Serial Number:	XXXXXXXXXX				
UUID Number:	XXXXXXXXXX XXXXXXXXXX				
System Memory:	640 KB	Show System Memory Size			
Extended Memory:	127 MB	Show Extended Memory Size			
F1 Help ↑↓ Select Item F5/F6 Change Values F9 Setup defaults					
Esc Exit ←→ Select Menu Enter Select ▶ Sub-Menu F10 Save and Exit					

UUID Number

UUID = 16 bytes

System Memory

This field reports the memory size of system base memory. The size is fixed to 640KB.

Extended Memory

This field reports the memory size of the extended memory in the system.
Extended Memory size = Total memory size - 1 MB

Exit Menu

PhoenixBIOS Setup Utility					
Main	System Devices	Security	Boot	Info.	Exit
Saving Changes and Exit		Item specific Help			
Discarding Changes and Exit		Exit System Setup and save your changes to CMOS			
Get Default Values		Exit utility without saving Setup data to CMOS.			
		Load default values for all SETUP item.			
F1 Help ↑↓ Select Item F5/F6 Change Values F9 Setup defaults					
Esc Exit ←→ Select Menu Enter Select ▶ Sub-Menu F10 Save and Exit					

Saving Changes and Exit

Allows the user to save changes to CMOS and reboot the system. The following message is shown when user presses "Enter" on the item.

Setup Confirmation
Save configuration changes and exit now
[Yes] [No]

System will reboot if Yes is selected and will stay in Setup if No is selected.

Discarding Changes and Exit

Allows the user to not save changes before exiting Setup. The following message is shown when user presses "Enter" on this item.

Warning Configuration has not been saved! Save before exiting? [Yes] [No]

System will reboot after either selection.

Get Default Values

Allows the user to load default values in CMOS Setup. The following message is shown when user presses "Enter" on this item:

Setup Confirmation Load default configuration now? [Yes] [No]
--

It still stay in Setup after either selection.

OS Compatibility

OS	Retail Support
MS-DOS	Minimal (Diagnostics and Manufacturing utilities)
Microsoft XP Home Edition	Full
Microsoft XP Professional Edition	Full
Microsoft Windows 2000	Not supported
Microsoft Windows Millennium	Not supported
Microsoft Windows 98 Second Edition (ACPI only)	Not supported
Microsoft Windows NT 4.0 SP5+	Not supported

Software Specification for KB-BIOS

General purpose

This document define the EC specification with standard interface and also define the special feature for OEM function .It's useful for software engineer to access EC status,and for SA test guide.

Features

- Advanced Power Management 1.2 support
- ACPI1.0 b and PC2001 compliant
- Support SMBus specification V1.0
- Hot keys for system control
- Audio volume output control
- External LED control
- Battery scope report and control
- Battery learning support
- Sticky key support
- Power switch control
- Speaker control
- Port replicator
- Extra key emulation
- Two host interface channels support
- Supports three independent devices
- Devices Hot Plug-and Play/Hot swapping configuration
- Internal Keyboard country selection

Types of KB-BIOS provided

- Standard version

Support for US(87)/UK(88)/Japanese(90) keyboard.

KB-BIOS command support with SYSTEM-BIOS

Command set 40h-4Fh for OEM defined through Port60/64 and Port62/66

Command Set (from system's point of view) via 60/64 and 62/66

CMD	DATA	Description	return
40h		Boot fail restart	
	0x01-0x7F	Boot fail restart, write in a byte to EC and enable the timer. This command called by BIOS and will cause the system reboot after the byte count down to zero if system still no reset the counter. It could make sure the system success boot up.	None

CMD	DATA	Description	return
41h		EC state notification	
	A0h	Return core code version number	One byte
	A1h	Return platform id	'COMPAL'
42h		Bank assign for EEPROM	None
	0x00-0x07	Bank assign for EEPROM,work with 4D/4E command replace 4B/4C command	None
43h	00h - FFh	Get RAM value from EC, Host can use this command to send address to get OEM RAM value. The address range are from 00h to DFh.	1 WORD
	0x19	Get PANEL ID	Panel id
44h	None	Get project ID	0x12
45h		Hook for every projects	NONE
46h		fan speed read	
	01h	fan speed 1 N = 60M/return value(rotate one circle 4 pulses) N = 120M/return value(rotate one circle 2 pulses)	2 bytes (high byte, low byte)
	02h	Fan speed 2 N = 60M/return value(rotate one circle 4 pulses) N = 120M/return value(rotate one circle 2 pulses)	2 bytes (high byte low byte)
47h		Speaker mute On/Off	
	A7h	Mute off	None
	A8h	Mute on	None
48h		Reserved for docking control	None
49h		Thermal control notification	
	A0h	Fan off	None
	A1h	Fan speed level 1	None
	A2h	Fan speed level 2	None
	A3h	HCT enable	None
49h	A5h	Fan speed level 4	None
4Ah		Auto into S2R(Delay about 4 Secs) or S2D and resume by timeout, This command provided engineer to verify S2R or S2D and resume function is OK or not Resume count(second base), Range is from 0x02 to 0x7F Bit7 = 0 -> Enabled S2R function 1 -> Enabled S2D function	
	0x02-0x7F	Enabled S2R function	None
	0x80-0xFF	Enabled S2D function	None

CMD	DATA	Description	return
4Bh		Write the data to device through SMBus interface	
	1 00h-FFh	Slave address of device	
	2 00h-FFh	Lo byte address if device is EEPROM otherwise is command or register	
	3 00h-FFh	Hi byte address if device is EEPROM, otherwise is zero	
		data byte to write	0=Write OK 0xFE = Fail
4Ch		Read data from devices through SMBus	
	1 00h-FFh	Slave address of device	
	2 00h-FFh	Lo byte address if device is EEPROM otherwise is command or register	
	3 00h-FFh	Hi byte address if device is EEPROM, otherwise is zero	data byte (00h-FFh)
4Dh		Write byte into EEPROM	
	1 00h-FFh	EEPROM address	
	2 00h-FFh	Data byte for write byte	0=Write OK 0xFE = Fail
4Eh		Read byte from EEPROM	
	00h-FFh	EEPROM address	Data byte 0xFE = Fail
4Fh		Reserved for R591 utility	None

Command set 50h-5Fh for OEM defined through Port60/64 and Port62/66

Command Set (from system's point of view) via 60/64 and 62/66

CMD	DATA	Description	return
50h	None	Get Docking status.	A0h = No dock A6h = simple docked
51h	None	Get revision number of KB-BIOS	BIOS Rev. 3 bytes byte0 : bit0-bit2 = major number(0-7) bit3-bit7 = type of KB-BIOS e.g. 0 = A, 1=B and so on.. byte1 minor revision number(0-9) byte2 If it is 00h then system display "ROM", other It is "T01" if it is 01h and so on..
52h	None	Hook for every projects(Get platform ID)	5Bytes "ACY25"
53h	None	Reserved	None
54h	0x00-0xFF	EC CMOS RAM read	Data byte from CMOS
55h		EC CMOS RAM write	
	0x00-0xFF	CMOS address offset	
	0x00-0xFF	data byte	0x00 => pass 0x01 => fail
56h		Get SMI trigger source	One byte
		Battery status change	80h
		Ask suspend(On mode)	A0h
		brightness level update	A1h
		contrast level update	A2h
		audio volume decreased	A3h
		audio volume increased	A4h
		Lid open	A5h
		Lid closed	A6h
		External device plugged	A7h
		External device removed	A8h

CMD	DATA	Description	return
		Bluetooth wake up event	A9h
		Bluetooth switch event	Aah
		Scr expand event	Abh
56h		Cpu fast event	Adh
		Cpu slow event	Aeh
		Pop up event	Afh
		Resume request from suspend	B0h
		Ask time out event	B1h
		Battery life in critical low state	B2h
		Battery life in low power state	B3h
		Standby request	B4h
		Battery Plug-In	B5h
		Battery Plug-Out	B6h
		Reserved	B7h
		Suspend to RAM request	B8h
		Save to DISK request	B9h
		Docked request	Bah
		Undock request	Bbh
		Reserved	Bch
		Thermal change event	Bdh
		Write LM75 event	Beh
		SMBus event	Bfh
		Password event	C0h
		mute function toggle	C1h
		Power button pressed	C2h
		TV out toggle	C3h
		Beep Alarm event	C4h
		Reserved	C5h
		Change use battery	C6h
		AC power plug-in	C7h
		AC power plug-out	C8h
		IR toggle event	C9h
		Modem Ring In	Cah
		Unload OS Ultra Base Devices	Cbh
		Surprise undock event	Cch
		Battery polling	Cdh
		PME signal active	Ceh

CMD	DATA	Description	return
		Mouse hot plug event	Cfh
56h		CRT plug in/out event	D0h
		Sleep button event	D1h
		RTC date/time update event	D2h
		Device change event	F0h
		Bluetooth lan event	F1h
		no event	FFh
57h	None	Module identification	One byte bit0 : Ext. FDD exis bit1 : Int. FDD exist bit2 : IDE exist other bit : Reserved
58h	0x00-0xFF	Set flat panel type	None
59h		System state notification	None
	70h	Sticky key mode enable	None
	71h	Sticky key mode disable	None
	80h	start to get LCD status panel information from EEPROM	None
	90h	One touch button application allow to send scan code(user button) if user pressed	None
	91h	One touch button application don't allow to send scan code(user button) if user pressed	None
	92h	Mail message is waiting(no support in Hurricane)	None
	93h	Mail message end of waiting(no support in Hurricane)	None
	94h	Mute on	None
	95h	Mute off	None
	9Ah	Ac off(cut off AC power)	None
	9bh	Ac on	None
	A2h	System enter S2D(S4) state	None
	A3h	System enter beep mode for battery LB state in CMOS setup	None
	A4h	System enter quiet mode for battery LB state in CMOS setup	None
	A5h	Fan control by EC	None
	A8h	Fan control by OS	None
	A9h	external PS2 only	None

CMD	DATA	Description	return
	Aah	Both enable external PS2 and internal touch pad	None
	Ach	Auto enable/disable external PS2 and internal touch pad	None
	B1h	System into standby	None
	B2h	Resume from standby	None
	B5h	VGA suspend enable	None
	B6h	VGA suspend disable	None
	B8h	Modem ring disable	None
	B9h	PME enable	None
	Bah	PME disable	None
	Bbh	S4 status bit clear	None
	Bch	S4 status bit set	None
	C1h	force battery pack auto learning	None
	C2h	disable battery pack learning	None
	C3h	SMI/SCI Trigger event enable	None
	C4h	SMI/SCI Trigger event disable	None
	Cbh	PCMCIA suspend disable	None
	Cch	PCMCIA suspend enable	None
	Cdh	Wake up LAN disable	None
	Ceh	Wake up LAN enable	None
	D0h	Disable IRQ1	None
	D1h	Enable IRQ 1	
	D2h	Beep alarm 100mS	None
	D5h	PCMCIA reset off	None
	D6h	PCMCIA reset on	None
	E1h	Turn LCD back-light on	None
	E2h	Turn LCD back-light off	None
	E5h	Select US keyboard Matrix	None
	E6h	Select JP keyboard Matrix	None
	E7h	Select UK keyboard Matrix	None
	E8h	EC into ACPI mode	None
	E9h	Non-ACPI mode (EC default)	None
	F2h	disable watchdog	None
	F3h	enable watchdog	None
	F4h	enable RTC access by EC	None
	F5h	disable RTC access by EC	None
	F6h	Clear header of Boot code	None

CMD	DATA	Description	return
	F7h	Restart system and Clear header of Boot code	None
	F8h	Shut down system and Clear header of Boot code	None
	F9h	Clear header of Boot code	None
5Ah		RTC update	
	1 A0h	Update Year of RTC ,Year(00-99) BCD format	
	2 00-99	Year which want to display	None
	1 A1h	Update Month of RTC ,Month (1..12) BCD format	
	2 01-12	Month which want to display	None
	1 A2h	Update DAY of RTC ,Day(01-07) BCD format	
	2 01-07	Day which want to display	None
	1 A3h	Update HOUR of RTC ,Hour(00-23) BCD format	
	2 00-23	Hour which want to display	None
	1 A4h	Update Minute of RTC ,Minute (0..59), BCD format	
	2 00-59	Minutes which want to display	None
	1 A5h	Update Second of RTC ,Second (0..59), BCD format	
	2 00-59	Seconds which want to display	None
5Bh		Reserved	
5Ch	None	Get brightness level	current brightness level (0x00-0x0a)
5Dh		Set brightness level	
	0x00h-0x0ah	new brightness level	None
5Eh	None	Get contrast level	Current contrast level (0x00-0x40)
5Fh		Set contrast level	
	0x00h-0x40h	new contrast level	None

Hot keys for system control

- Definitions

All Fn Key will support Sticky key mode.

<i>Fn + F5</i>	<i>Force Switching Display Mode(LCD->CRT->Simulataneous)</i>
<i>Fn + F10</i>	<i>Cursor keypad on/off.</i>

	<i>Pressing this hot key can enable/disable the embedded cursor keypad. Numeric lock state is logically disable.</i>
<i>Fn + F11</i>	<i>Num keypad on/off Pressing this hot key can enable/disable the embedded Numeric keypad. Numeric lock state is logically enable.</i>
<i>Fn + F12</i>	<i>Scroll Lock on/off</i>
<i>Fn + ↑</i>	<i>Increase Brightness (total 10 levels)</i>
<i>Fn + ↓</i>	<i>Decrease Brightness (total 10 levels)</i>

After rebooting, pad lock is set to off and Num lock is set to on. In this state, the embedded cursor/number pad is not enabled on the notebook keyboard.

Note: Hot keys for brightness/contrast adjustment are in repeat mode, others will only be updated once for each key depression.

Audio volume output control

Use Volume Up/Down Button for Increasing/Decreasing respectively, it controls the volume output of the audio chip.

External Buttons status report and control

Define the function of buttons which is controlled by EC.

Power Switch

- *If system is Off/S2D : System will be turned on while Power switch is depressed by more than 500 ms with or without AC insert*
- *If system is in S2R/Standby state : System will resume while Power switch is depressed by more than 100 ms*

Mechanical off button

- *It will reset KB-BIOS then turn off system. This signal connect to 591 LREST to do hardware reset.*

Wireless on/off switch

It will enable/disable wireless function.

One touch Button

- *Support 2 one touch buttons, it will launch homologous application.
User Button 1: press this button can launch default defined Internet application.
User Button2 : press this button can launch default defined E-mail browser application.*

External LEDs status report and control

Define the Led display status.

Definitions of Lock LEDs

- *Caps lock LED: Caps Lock State of Keyboard*
- *Num Lock LED: Num Lock State of Keyboard*

Definitions of System state LED

- There is one dual-color LED indicator both of Green and Amber color
- Green color support for System state. The definition is in below:
Green color activity : System On.
Green color off : System Off.
- Amber color support for power management state. The definition is below:
Amber color activity : System in sleep(S1 state) or S2R mode(S3 state).
Color off : Not in power management mode.

Definitions of DC-DC state LED

- *Green color : for battery charging state.*
Green color activity:Battery charging with AC(green LED on for 1sec per 4 sec)
Green color on : Battery full by AC charge.
Green color off : Battery full/discharge
- *Amber color(Green and Red) : for battery discharge state.*
Amber color activity : battery within low state(remain 12 minutes left)
Amber color blinking : battery in critical low state(remain 3 minutes left).
LED flash once per second.
Amber color off : Battery charging
- *Red color : Stop charge by battery Bad cell, Over temperature or charging protection.*

Definitions of Wireless on/off State LED

- *Blue color: Wireless power on.*
- *Off: Wireless power off.*

Battery status report and control

Define the battery type spec and battery protection function.

Battery status

- There are four battery states for each battery pack depend on getting the battery state through SMBus protocol from Smart battery pack: full, normal, low, critical low.
- The battery gas-gauge and level of low power states should base on 'current' system configuration.
- Battery turn on system condition : gasgauge > 5%

Battery discharge/charging control

Charging	Discharging	Action
Charging : $0^{\circ}\text{C} < T < 50^{\circ}\text{C}$ Stop charging: $T > 60^{\circ}\text{C}$		Stop charging & Red Led on
$T > 73^{\circ}\text{C}$	$T > 73^{\circ}\text{C}$ $T > 73^{\circ}\text{C}$	Shut down
	R.S.O.C. $\leq 10\%$	LB(Beeping)
	R.S.O.C. $< 3\%$	LLB Dependent on OS
	TBD	LLC Shut down System
	R.S.O.C $< 5\%$ during system is in S2R mode.	S2D
Fast Charge Time out: 8 Hours Trickle Charge Time Out: 1 Hour.		Battery BAD & Red Led on
TBD		OverVoltage & Red Led on

In ACPI mode

- System should 'Save to Disk'(S2D) or beeping(Low condition) depend on OS setting .

Battery type

- The KB-BIOS will support for **smart** battery pack by SMBus protocol.
- ACPI1.0b and PC2001 Compliant,with PC2001 spec "A mobile system must use a Smart Battery or an ACPI control method battery",our currently design is ACPI control method battery.

Li-ion Battery : ~~14.8V/3900mAH(4S2P)~~

14.8V/4000mAH(4S2P)

Ni-MH Battery : No Support

- Compatible with Intel's SMBus and Philip's I2C bus protocol.

KB-BIOS Power management support

EC will support S1(sleep mode),S3(standby mode),S4(suspend to disk) mode to save the power consumption.

Power states

- Sleep mode
LCD panel back-light off
- Save to RAM
keyboard(int./ext.) scanning off
- Save to DISK
no actions except turning off system with AC exist or turn off KBC without AC.

SMI/SCI/SWI/SBS/SPB events(To be Changed)

- Following list is which events(SMI/SCI/SWI/SBS) will be generated under different OS.

Function Description	APM Mode				ACPI mode					
	ON mode	S2R mode	S2D mode	Trigger event	S0 status	S1,S2,S3 status	S4 status	S5 status	SCI event	SWI event
Brightness level changed	SMI	-	-	A1h	SCI	-	-	-	11h	-
Contrast level changed	SMI	-	-	A2h	SMI	-	-	-	12h	-
CoverLid close	SMI	-	-	A6h	SCI	-	-	-	16h	-
Display toggle	SMI	-	-	Ach	SCI	-	-	-	1ch	-
Battery in critical low	SMI	SMI	-	B2h	SCI	SCI	-	-	22h	-
Battery in low state	SMI	-	-	B3h	SCI	-	-	-	23h	-
Standby request	SMI	-	-	B4h	-	-	-	-	24h	-
Battery pack plugin	SMI	-	-	B5h	SBS	-	-	-	25h	-
Battery pack removed	SMI	-	-	B6h	SBS	-	-	-	25h	-
Suspend To RAM request	SMI	-	-	B8h	SCI	-	-	-	28h	-
Save To DISK request	SMI	-	-	B9h	-	-	-	-	29h	-
Docking in	SMI	-	-	Bah	SCI	SPB	-	-	2ah	-
Undock	SMI	-	-	BBh	SCI	-	-	-	2bh	-
AC plugin	SMI	-	-	C7h	SBS	-	-	-	37h	-
AC removed	SMI	-	-	C8h	SBS	-	-	-	38h	-
Modem ringin	SMI	-	-	Cah	-	SPB	-	-	3ah	04
PME signal active	SMI	SMI	-	Ceh	SCI	SPB	-	-	3eh	02
CRT plugin/out	SMI			D0h	SCI				40h	
RTC Update	SMI			D2h	SCI				42h	

Thermal Status Report and Fan Control

EC will control fan on/off function according to the CPU temperature(EC can get temperature from thermal sensor through SMBus) .In currently spec,Fan will be off when temperature below

55°C ~~50°C~~ ,and if temperature over 92°C ~~85°C~~ five times,EC will auto turn off system to protect CPU.For detail data please reference follows table.

Fan State & System State	Temperature
Fan Off	55°C 50°C
Fan on 3.5V	70°C 60°C
Fan on 5V	76°C 65°C
Throttling on	78°C
Throttling off	65°C
Turn off Fan & shut down	92°C 85°C

Port replicator and Docking station

Button control

- The power switch and power kill button on docking station was identical to the one on the NoteBook PC.
- Software controlled mechanical interlock and eject button.

Docked and undock control

- Support for cold dock ,warm dock ,hot dock and hot undock .
- Support for Software and Hardware eject with AC power source exist.

LEDs indicator

There are two LED indicators in SPR: System state LED and DC-DC state LED.

Extra keyboard emulation

Windows key emulation

- Left/Right windows keys both depressed: Fn and Application key depressed simultaneously.
- Right window key : press Fn+Left window key.

Fn Key emulation (Not support)

- External keyboard Fn-key emulation except Pad-Lock by pressing both Left Ctrl and Left Alt of external keyboard. It will not work on USB keyboard.

Internal Key-Pad mode control

		Number lock on	Key pad on	Number lock and Key pad both on	Number lock and Key pad both off
Single key	U	4	Left key	4	U
	J	1	End key	1	J
	:	:	:	:	:
Fn +	U	U	U	U	Left key
	J	J	J	J	End key
	:	:	:	:	:

We have several keys support keypad mode. List as below:

“7,”8,”9,”0,”U,”I,”O,”P,”J,”K,”L,”,”,”M,”.”/”.

Other Fn key

- *Scroll lock* :press Fn + F12
- *Numeric keypad lock*: Fn + F11
- *Pad lock*: Fn + F10

Two host interface channels support

Keyboard and mouse interface transfer port

- One channel is dedicated for the keyboard and mouse data transfer(host address 60h and 64h). The Keyboard and Mouse channel of KBC is compatible to the legacy 8042 host interface. It is base on two registers: Command/Data and Status
- The KB-BIOS interrupt generates IRQ1(Keyboard) and IRQ12(Mouse) for system.

Power management interface transfer port

- The other for the power management function(host address 62h and 66h). The Power Management channel of KBC structure and operation are similar to those of the Keyboard/Mouse channel.

Support three independent devices

- The KBC provides three data transfer channels. Each channel has two quasi-bidirectional signals that are used for the direct interface to an external keyboard, mouse or any other PS/2 compatible pointing device.
- The three channels are identical and thus allow the connector ports to be interchangeable.

Devices PnP configuration

Hot Plug-and-Play support

- The KBC watches both external devices, checking if the devices have recently been plugged in or unplugged. The Hot pluggability of external PS2 devices feature detects the attachment or removal of these devices.

Hot swapping control

- When the device is plugged in, the software automatically initializes the state of that device, checks port swapping, and setup the KBC to handle dual-device operation. In dual-device operation, the internal device is set in the same state as external device. When the external device is unplugged, the internal device becomes the primary device.

ACPI EC interface Specification support

ACPI interface support

- The KBC provides support for Advance Configuration and Power Interface specification(ACPI) Embedded Controller interface.

EC command support

- The 2nd (Power Management) host interface channel of the KBC is dedicated to this function.
- All EC commands defined in the ACPI specification - Read/Write, Burst Mode enable/disable and Query command - are supported.

Internal keyboard change Configuration

US/UK/JP country option

- The KBC supports three country selection by KBD_SEL application.
- You can key in KBD_SEL get the syntax for your option at DOS prompt.

Sticky key support

- Press shift key 5 times will enable sticky key function. Turns on StickyKeys, which allows you to press a modifier key (CTRL, ALT, or SHIFT), or the windows logo key, and have it remain active until the next time you press a key other than CTRL, ALT, SHIFT, or windows logo key. This is useful for people who have difficulty pressing two keys simultaneously.

EC name space Configuration

SMBus EC interface ACPI RAM definition

Offset	Description
60h	SMBus protocol
61h	SMBus statue Bit0-Bit4 – Status Bit5 – Reserved Bit6 – ALARM Bit7 – DONE
62h	SMBus Address
63h	SMBus Command
64h – 83h	SMBus Data
84h	SMBus BCNT
85h	SMBus alarm address
86h	SMBus alarm data 0
87h	SMBus alarm data 1

Word registers to Emulate smart charge RAM definition

Offset	Description
90h – 91h	CHG_MODE0 CHG_MODE1 Bit0 – INHIBIT_CHARGE(0=enabled, 1=inhibit) Bit1 – ENABLE_POLLING(0=disable, 1=enable) Bit2 – POR_RESET(0=Mode unchanged, 1=set power on defaults) Bit3 – RESET_TO_ZERO(0=No change, 1=set charging values to zero) Bit4-15 – Reserved
92h – 93h	CHG_STAT0 CHG_STAT1 Bit0 – CHARGE_INHIBITED(Status of bit in CHG_MODE register) Bit1 – MASTER_MODE(Set if HOST controlled & ENABLE_POLL) Bit2 – VOLTAGE_NOTREG(Set if CHG_VOLT not in regulation) Bit3 – CURRENT_NOTREG(Set if CHG_CURRENT not in regulation) Bit4 – LEVEL_2(Set always at least level 2) Bit5 – LEVEL_3(Set always if level 3 capable)

Offset	Description
	<i>Bit6 – CURRENT_OR(Set if CHG_CURRENT out of range)</i> <i>Bit7 – VOLTAGE_OR(Set if CHG_VOLT out of range)</i> <i>Bit8 – THERMISTOR_OR(Set if thermistor R>100K Ohms)(Open)</i> <i>Bit9 – THERMISTOR_COLD(Set if thermistor R>30K Ohms)(Cold Batt)</i> <i>Bit10 – THERMISTOR_HOT(Set if thermistor R<3K Ohms)(Hot Batt)</i> <i>Bit11 – THERMISTOR_UR(Set if thermistor R<500 Ohms)(Under range)</i> <i>Bit12 – ALARM_INHIBITED(Set if charging inhibited from Alarm)</i> <i>Bit13 – POWER_FAIL(Set if power fail)</i> <i>Bit14 – BATTERY_PRESENT(Set if battery present)</i> <i>Bit15 – AC_PRESENT(Set if charging power source available)</i>
94h – 95h	CHG_CURRENT0 CHG_CURRENT1 <i>Bit0-Bit15 – Requested charging current(mA)</i> <i>0=Turn off charger</i> <i>65535=Provide maximum safe charger current</i>
96h – 97h	CHG_VOLT0 CHG_VOLT1 <i>Bit0-Bit15 – Requested charging voltage(mV)</i> <i>0=Turn off charger</i> <i>65535=Provide maximum safe charger voltage</i>
98h – 99h	CHG_ALARM0 CHG_ALARM1 <i>*** Alarm Bits ***</i> <i>0x8000 – OVER_CHARGED_ALARM</i> <i>0x4000 – TERMINATE_CHARGE_ALARM</i> <i>0x2000 – RESERVED</i> <i>0x1000 – OVER_TEMP_ALARM</i> <i>0x0800 – TERMINATE_DISCHARGE_ALARM</i> <i>0x0400 – RESERVED</i> <i>0x0200 – REMAINING_CAPACITY_ALARM</i> <i>0x0100 – REMAINING_TIME_ALARM</i> <i>*** Status Bits ***</i> <i>0x0080 – INITIALIZED</i> <i>0x0040 – DISCHARGING</i> <i>0x0020 – FULLY_CHARGED</i> <i>0x0010 – FULLY_DISCHARGED</i> <i>*** Error Code ***</i> <i>0x0000 – 0x000F – All bits set hi prior to AlarmWarning() xmit</i>

Word registers to Emulate smart selector RAM definition

Offset	Description
9Ah	<p>SEL_STATE0</p> <p>Bit0 – PRESENT_A(Set if 1st battery present) Bit1 – PRESENT_B(Set if 2nd battery present) Bit2 – PRESENT_C(Set if 3rd battery present) Bit3 – PRESENT_D(Set if 4th battery present) Bit4 – CHARGE_A(Set if 1st battery be charging) Bit5 – CHARGE_B(Set if 2nd battery be charging) Bit6 – CHARGE_C(Set if 3rd battery be charging) Bit7 – CHARGE_D(Set if 4th battery be charging)</p>
9Bh	<p>SEL_STATE1</p> <p>Bit0 – PWR_BY_A(Set if system power up by 1st) Bit1 – PWR_BY_B(Set if system power up by 2nd) Bit2 – PWR_BY_C(Set if system power up by 3rd) Bit3 – PWR_BY_D(Set if system power up by 4th) Bit4 – SMB_A(Set if 1st battery on SMBus) Bit5 – SMB_B(Set if 2nd battery on SMBus) Bit6 – SMB_C(Set if 3rd battery on SMBus) Bit7 – SMB_D(Set if 4th battery on SMBus)</p>

EC interface OEM common RAM definition

Offset	Description
9Ch	<p>ACPI_FLAG0</p> <p>Bit0 – Primary HDD(1:exist) Bit1 – Internal FDD(1:exist) Bit2 – CDROM(1:on) Bit3 –Secondary HDD(1:exist) Bit4 – LS120(1:exist) Bit5 – External FDD(1:exist) Bit6 –CRT plug in (1:exist) Bit7 – Reserved</p>
9Dh	<p>ACPI_FLAG1</p> <p>Bit0 – Sleep button(1:pressed) Bit1 – Video out button(1:pressed) Bit2 – Decrease Volume(1:pressed) Bit3 – Increase Volume(1:pressed) Bit4 – Mute button(1:pressed) Bit5 – Contrast button(1:pressed) Bit6 – Brightness button(1:pressed) Bit7 – Save to disk button(1:pressed)</p>
9Eh	<p>ACPI_FLAG2</p> <p>Bit0 - ACPI entry S4 state Bit1 – Password button status Bit2 – Spark beep button status Bit3 – Touchpad button status Bit4 –Bit7 Reserved.</p>
9Fh	Reserved
A0h	<p>UbStatus: Ultra Base control pin status</p> <p>Bit0 – DPWR, Turn on Dock PCI power(0=off, 1=on)</p>

Offset	Description
	<i>Bit1 – UDRF, Undock request(0=inactive, 1=undock & flash LED)</i> <i>Bit2 – UDRS, Undock request(0=inactive, 1=undock & solid LED)</i> <i>Bit3 – EQBF, Enable Q-Buff(0=disable, 1=enable)</i> <i>Bit4 – DWELL, Docked well LED(0=LED off, 1=LED on)</i> <i>Bit5 – QVCCOK, Dock power ready status(0=No, 1=Yes)</i> <i>Bit7 –CheckEject , (SoftEject request : 0=No 1=Yes)</i>
A1h	<i>DCID: Customer ID</i> <i>Bit0 –DockType0, Dock on or not(0=off, 1=on)</i> <i>Bit1 –DockType1, reserved</i> <i>Bit4 – OS_undock OK</i> <i>Bit5 – OS dock OK</i> <i>Bit6 – Safe Undock OK</i> <i>Bit7 –DockChange, Ultra Base had changed from docked to undock or undock to dock (0=no, 1=yes)</i>
A2h	<i>Battery Learning steps.</i>
A3h	<i>SYS_STATUS: System indicator</i> <i>Bit0 – S0LED, S0 state LED(0=LED off, 1=LED on)</i> <i>Bit1 – S3LED, S3 state LED(0=LED off, 1=LED on)</i> <i>Bit2 – VGAQ, VGA H/W suspend(0=VGA on, 1=VGA suspend)</i> <i>Bit3 – PCMQ, PCMCIA H/W suspend(0/1=PCMCIA on/suspend)</i> <i>Bit4 – PCMR, PCMCIA H/W reset (0=disable, 1=enable)</i> <i>Bit5 –ADP,Ac adapter (0=offline, 1=online)</i> <i>Bit6 –SYSR6(reserved)</i> <i>Bit7 –SYSR7(reserved)</i>
A4h	<i>WAKEUP_ENABLE: Enable wake up function</i> <i>Bit0 –PMEWAKE(PME Wk Enable:0=Disable, 1=Enable)</i> <i>Bit1 –MDMWAKE (Modem Wk Enable:0=Disable, 1=Enable)</i> <i>Bit2 - LANWAKE(LAN wakeup enable:0=Disable, 1=Enable)</i> <i>Bit3-Bit7 – reserved</i>
A5h	<i>FANOFF_TEMP: Fan off temperature level</i>
A6h	<i>FANSPD1_TEMP: Fan on speed 1t</i>
A7h	<i>FANSPD2_TEMP: Fan on speed 2</i>
A8h	<i>FANSPD3_TEMP: Fan on speed 3</i>
A9h	<i>FANSPD4_TEMP: Fan on speed 4</i>
AAh	<i>FANSPD5_TEMP: Fan on speed 5</i>
ABh	<i>FANSPD6_TEMP: Fan on speed 6</i>
ACH	<i>FANSPD7_TEMP: Fan on speed 7</i>
ADh	<i>Temperature index</i>
A Eh	<i>Reserved</i>
AFh	<i>THERMAL_STATUS</i> <i>Bit0 – MODE (0=Local mode, 1=Remote mode)</i> <i>Bit1 – FANSPDB0(Fan on/off parameter0)</i> <i>Bit2 – FANSPDB1(Fan on/off parameter1)</i> <i>Bit 2 1 (When control by OS)</i> <i>0 0 : Fan off</i>

Offset	Description
	0 1 : Fan on speed 1 1 0 : Fan on speed 2 1 1 : Fan on speed 3 Bit3 – INITOK (0:Control by OS 1:Control by EC) Bit4 – Fan1 Active Bit5 – Fan2 Active Bit6 – Fan speed timer init OK
B0h	CPU_TEMP: CPU current temperature
B1h	SWI_Events: SWI Event indicators Bit1 – Lid Open, Lid open event (0= off, 1= on) Bit2 – PME, PME event (0= off, 1= on) Bit3 –Power Button, Power button event (0= off, 1= on) Bit4 –Ring In, Ring In event (0= off, 1= on) Bit5 – BtWake,Bluetooth wake up event(0=off,1=on) Bit6 – Dock ,Dock in event(0=off,1=on)
B2h	Percentage : Battery in critical low condition.
B3h	Percentage : Battery in low condition.
B4h	Fan1 pulse width low byte
B5h	Fan1 pulse width high byte
B6h	Fan2 pulse width low byte
B7h	Fan2 pulse width high byte
B8h	Bluetooth Status Bit0 – Detach(0=Detach, 1=Attach) Bit1 – Power(0=power off, 1=power on) Bit2 – Detach Status(0=Detach OK, 1=Attach OK) Bit3 –Power Status(0=Power off OK, 1=Power on OK) Bit4 – Switch(0=switch off, 1=switch ok) Bit5 –wake up Bit6 –Bluetooth led(0=led off, 1=led on)
B9h	Lcd brightness value (0x00-0x0a)
BAh	Lcd contrast value (0x00-0x1F)
BBh	Reserved
BCh	Project ID
BDh	Reserved
BEh	I/TOC timer low byte
BFh	I/TOC timer high byte
F9h	Fan1 RPM low byte
FAh	Fan1 RPM high byte
FBh-FFh	Reserved

Control method for 1st battery pack RAM definition

Offset	Description
C0h	Bit4-6 – Manufacturer Bit 6 5 4 0 0 1 : Sanyo 0 1 0 : Sony 1 0 0 : Panasonic Bit7- Battery type 0 : Ni-MH 1 : Li-ion
C1h	Battery Status Bit0 – Discharging Bit1 – Charging Bit2 – Discharging and Now is critical low Bit3-7 – Reserved
C2h-C3h	Remaining Capacity
C4h-C5h	Serial Number
C6h-C7h	Present Voltage
C8h-C9h	Design Voltage
CAh-CBh	Design Capacity
CCh-CDh	Full charge capacity
Ceh	Gasgauge
CFh-D8h	Reserved

Control method for 2nd battery pack RAM definition

Offset	Description
E0h	Bit4-6 – Manufacturer Bit 6 5 4 0 0 1 : Sanyo 0 1 0 : Sony 1 0 0 : Panasonic Bit7- Battery type 0 : Ni-MH 1 : Li-ion
E1h	Battery Status Bit0 – Discharging Bit1 – Charging Bit2 – Discharging and Now is critical low Bit3-7 – Reserved

Offset	Description
E2h-E3h	<i>Remaining Capacity</i>
E4h-E5h	<i>Serial Number</i>
E6h-E7h	<i>Present Voltage</i>
E8h-E9h	<i>Design Voltage</i>
EAh-EBh	<i>Design Capacity</i>
ECh-EDh	<i>Full charge capacity</i>
EEh	<i>Gasgauge</i>
Efh-F8h	<i>Reserved</i>

Chapter 3: Hardware

Major Sub-assembly Specification

System interconnection (For BY25)

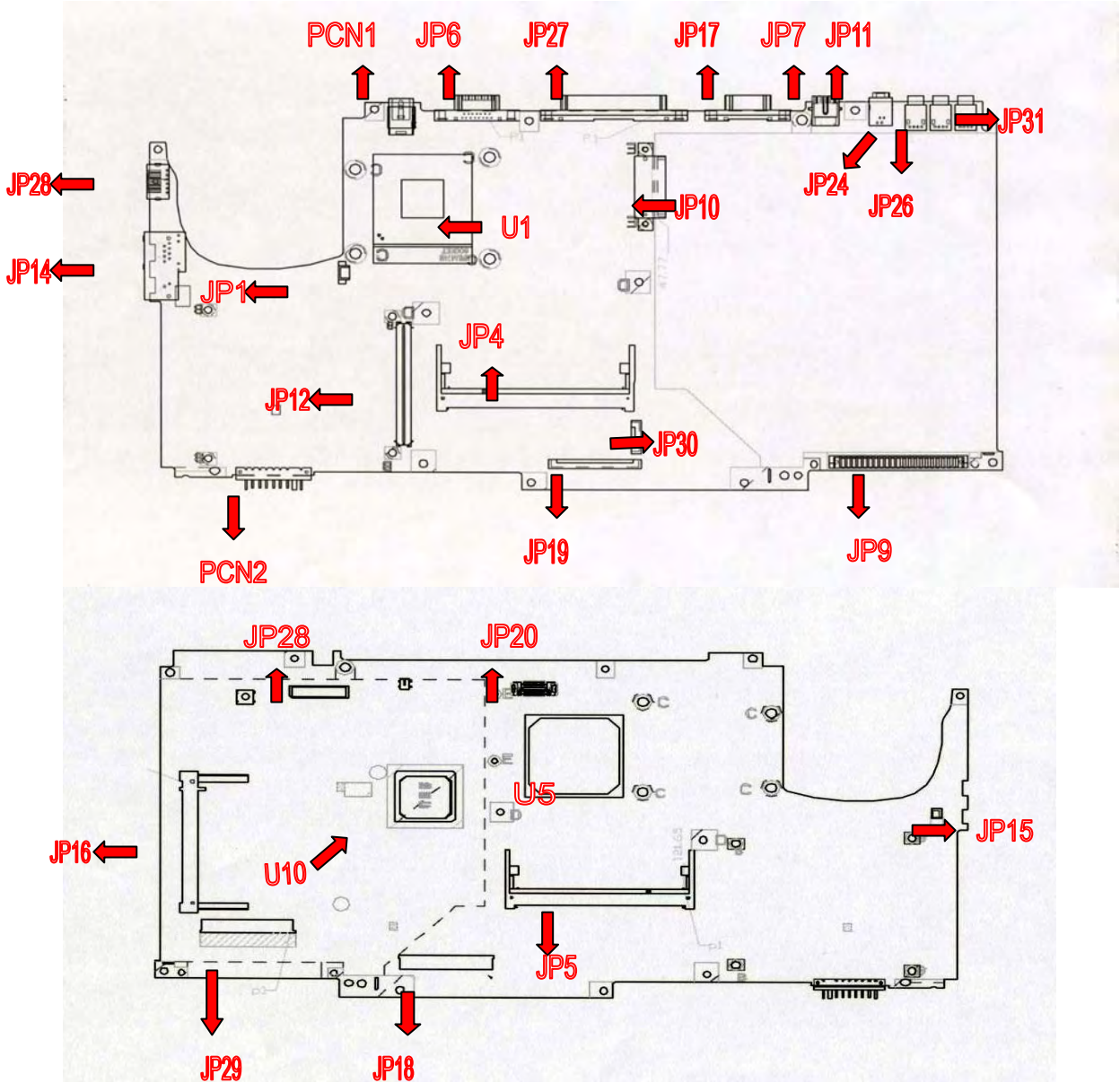

JP28 KBD/PS2_6.PRT
JP24,JP26,JP31 USB _CON..PRT
JP6 CRT CONN..PRT
JP1 LPTCN-27.PRT
JP9 HDD
PCN2 BATT-B.PRT
JP19 FDD.PRT
PCN1 DC JACK PRT
JP10 CDROM.PRT
JP12 PCMCIA-CONN. 84P.PRT
JP5 DDR-200P.PRT

JP18 Int. KB Interface CONN
U5 Northbridge

JP20 Switch button Interface CONN

JP1 CPU FAN CONN.
JP14 RJ45-11 CONN.
JP4 DDR 200P SO-DIMM
JP15 MODEM CONN
JP29 Audio M/B
JP16 MINI-PCI CONN
JP7 TV-OUT CONN
JP8 PANEL CONN
JP30 CARD READER CONN
JP11 1394 CONN

U1 CPU socket
U10 Southbridge

MOTHER BOARD

JP28 KBD/PS2_6.PRT

PIN NO	SIGNAL	PIN NO	SIGNAL
1.	KBD_DATA	2.	PS2_DATA
3.	GND	4.	VCC
5.	KBD_CLK	6.	PS2_CLK

JP24,JP26,JP31 USB _CON..PRT

PIN NO	SIGNAL	PIN NO	SIGNAL
1.	VCC	2.	USB(2,0,4)D-
3.	USB(2,0,4)D+	4.	GND

JP6 CRT CONN..PRT

PIN NO	SIGNAL	PIN NO	SIGNAL
1.	R_RED	2.	R_GREEN
3.	R_BLUE	4.	C
5.	GND	6.	GND
7.	GND	8.	GND
9.	CRTVDD	10.	GND
11.	MSEN#	12.	DDCDATA
13.	HSYNC	14.	VSYNC
15.	DDCCLK		

JP1 LPTCN-27.PRT

PIN NO	SIGNAL	PIN NO	SIGNAL
1.	+5V_PRN	2.	FD0
3.	FD1	4.	FD2

5.	FD3	6.	FD4
7.	FD5	8.	FD6
9.	FD7	10.	LPTACK#
11.	LPTBUSY	12.	LPTPE
13.	LPTSLCT	14.	LPTAFD#
15.	LPTERR#	16.	LPT_INIT#
17.	SLCTIN#	18.	GND
19.	GND	20.	GND
21.	GND	22.	GND
23.	GND	24.	GND
25.	GND		

JP9 HDD

PIN NO	SIGNAL	PIN NO	SIGNAL
1.	HD_IDERST#	2.	GND
3.	PD_D7	4.	PD_D8
5.	PD_D6	6.	PD_D9
7.	PD_D5	8.	PD_D10
9.	PD_D4	10.	PD_D11
11.	PD_D3	12.	PD_D12
13.	PD_D2	14.	PD_D13
15.	PD_D1	16.	PD_D14
17.	PD_D0	18.	PD_D15
19.	GND	20.	NC
21.	PD_DREQ	22.	NC
23.	PD_IOW#	24.	GND
25.	PD_IOR#	26.	GND
27.	PD_IORDY	28.	PD_CSEL
29.	PD_DACK#	30.	GND
31.	PD_IRQA	32.	NC
33.	PD_A1	34.	CBLIDA
35.	PD_A0	36.	PD_A2
37.	PD_CS#1	38.	PD_CS#3
39.	HDD_LED#	40.	GND
41.	+5VS	42.	+5VS
43.	GND	44.	+5VS

PCN2 BATT-B.PRT

PIN NO	SIGNAL	PIN NO	SIGNAL
1.	BATT+	2.	LI/NIMH#

3.	GND	4.	BATT_TEMP
5.	EEPROMVCC	6.	SMB_EC_CK1
7.	SMB_EC_DA1	8.	GND

JP19 FDD.PRT

PIN NO	SIGNAL	PIN NO	SIGNAL
1.	HDSEL#	2	GND
3	RDATA#	4	GND
5	WR#	6	GND
7	TRACK0#	8	GND
9	WGATE#	10	GND
11	WDATA#	12.	FDD_DET#
13.	STEP#	14.	3MODE
15	FDDIR#	16.	NC
17	MTR0#	18.	NC
19	NC	20.	NC
21	DISKCHG#	22.	+5VS
23	DRV0#	24.	+5VS
25.	INDEX#	26.	+5VS

PCN1 DC JACK PRT (70W)

PIN NO	SIGNAL	PIN NO	SIGNAL
1.	VIN	2.	GND

JP10 CDROM.PRT

PIN NO	SIGNAL	PIN NO	SIGNAL
1.	INT_CD_L	2.	INT_CD_R
3.	CD_AGND	4.	GND
5.	CD_IDERST#	6.	SD_D8
7	SD_D7	8.	SD_D9
9.	SD_D6	10.	SD_D10
11.	SD_D5	12.	SD_D11
13.	SD_D4	14.	SD_D12
15.	SD_D3	16.	SD_D13
17.	SD_D2	18.	SD_D14
19.	SD_D1	20.	SD_D15
21.	SD_D0	22.	SD_DREQ
23.	GND	24.	SD_SIOR#
25.	SD_SIOW#	26.	GND
27.	SD_SIORDY	28.	SD_DACK#

29.	SD_IRQ15	30.	NC
31.	SD_SBA1	32.	CBLIDB
33.	SD_SBA0	34.	SD_SBA2
35.	SD_CS1#	36.	SD_SCS3#
37.	CDLED#	38.	+5V_IDE
39.	+5V_IDE	40.	+5V_IDE
41.	+5V_IDE	42.	+5V_IDE
43.	GND	44.	+5VS
45.	GND	46.	GND
47.	SD_CSEL	48.	GND
49.	NC	50.	+5VS

JP12 PCMCIA-CONN. 84P.PRT

PIN NO	SIGNAL	PIN NO	SIGNAL
A1.	GND	A2.	GND
A3.	S1_D3	A4.	S1_CD1#
A5.	S1_D4	A6.	S1_D11
A7.	S1_D5	A8.	S1_D12
A9.	GND	A10.	S1_D6
A11.	S1_D13	A12.	S1_D7
A13.	S1_D14	A14.	S1_CE1#
A15.	S1_D15	A16.	GND
A17.	S1_A10	A18.	S1_CE2#
A19.	S1_OE#	A20.	S1_VS1
A21.	S1_A11	A22.	GND
A23.	S1_IORD#	A24.	S1_A9
A25.	S1_IOWR#	A26.	S1_A8
A27.	S1_A17	A28.	GND
A29.	S1_A13	A30.	S1_A18
A31.	S1_A14	A32.	S1_A19
A33.	S1_WE#	A34.	S1_A20
A35.	S1_RDY#	A36.	S1_A21
A37.	S1_VCC	A38.	S1_VCC
A39.	S1_VPP	A40.	S1_VPP
A41.	S1_A16	A42.	GND
A43.	S1_A22	A44.	S1_A15
A45.	S1_A23	A46.	S1_A12
A47.	S1_A24	A48.	S1_A7
A49.	GND	A50.	S1_A25

A51	S1_A6	A52	S1_VS2
A53	S1_A5	A54	S1_RST
A55	S1_A4	A56	S1_WAIT#
A57	GND	A58	S1_A3
A59	S1_INPACK#	A60	S1_A2
A61	S1_REG#	A62	S1_A1
A63	S1_BVD2	A64	S1_A0
A65	GND	A66	S1_BVD1
A67	S1_D0	A68	S1_D8
A69	S1_D1	A70	S1_D9
A71	S1_D2	A72	S1_D10
A73	GND	A74	S1_WP
A75	S1_CD2#	A76	GND
A77	GND		

PIN NO	SIGNAL	PIN NO	SIGNAL
B1.	GND	B2.	GND
B3.	S2_D3	B4.	S2_CD1#
B5.	S2_D4	B6.	S2_D11
B7	S2_D5	B8.	S2_D12
B9.	GND	B10.	S2_D6
B11.	S2_D13	B12.	S2_D7
B13.	S2_D14	B14.	S2_CE1#
B15.	S2_D15	B16.	GND
B17.	S2_A10	B18.	S2_CE2#
B19.	S2_OE#	B20.	S2_VS1
B21.	S2_A11	B22.	GND
B23.	S2_IORD#	B24.	S2_A9
B25.	S2_IOWR#	B26.	S2_A8
B27	S2_A17	B28	GND
B29.	S2_A13	B30.	S2_A18
B31.	S2_A14	B32.	S2_A19
B33.	S2_WE#	B34.	S2_A20
B35.	S2_RDY#	B36.	S2_A21
B37	S2_VCC	B38	S2_VCC
B39.	S2_VPP	B40.	S2_VPP
B41.	S2_A16	B42.	GND
B43.	S2_A22	B44.	S2_A15

B45.	S2_A23	B46.	S2_A12
B47.	S2_A24	B48.	S2_A7
B49.	GND	B50.	S1_A25
B51	S1_A6	B52	S1_VS2
B53	S1_A5	B54	S1_RST
B55	S1_A4	B56	S1_WAIT#
B57	GND	B58	S1_A3
B59	S1_INPACK#	B60	S1_A2
B61	S1_REG#	B62	S1_A1
B63	S1_BVD2	B64	S1_A0
B65	GND	B66	S1_BVD1
B67	S1_D0	B68	S1_D8
B69	S1_D1	B70	S1_D9
B71	S1_D2	B72	S1_D10
B73	GND	B74	S1_WP
B75	S1_CD2#	B76	GND
B77	GND		

JP5 DDR-200P.PRT

PIN NO	SIGNAL	PIN NO	SIGNAL
1.	MVREF_DIM	2.	MVREF_DIM
3.	GND	4.	GND
5.	MD0	6.	MD4
7	MD1	8.	MD5
9.	+2.5V	10.	+2.5V
11.	RDQS0	12.	GND
13.	MD6	14.	MD3
15.	GND	16.	GND
17.	MD2	18.	MD7
19.	MD8	20.	MD12
21.	+2.5V	22.	+2.5V
23.	MD9	24.	MD13
25.	RDQS1	26.	GND
27	GND	28	GND
29.	MD10	30.	MD14
31.	MD15	32.	MD11
33.	+2.5V	34.	+2.5V
35.	DDR_CLK0	36.	+2.5V
37	DDR_CLK0#	38	GND

39.	GND	40.	GND
41.	MD16	42.	MD20
43.	MD21	44.	MD17
45.	+2.5V	46.	+2.5V
47.	RDQS2	48.	GND
49.	MD18	50.	MD22
51	GND	52	GND
53	MD19	54	MD23
55	MD24	56	MD28
57	+2.5V	58	+2.5V
59	MD25	60	MD29
61	RDQS3	62	GND
63	GND	64	GND
65	MD30	66	MD26
67	MD31	68	MD27
69	+2.5V	70	+2.5V
71	GND	72	GND
73	GND	74	GND
75	GND	76	GND
77	RDQS8	78	GND
79	GND	80	GND
81	+2.5V	82	+2.5V
83	GND	84	GND
85	NC	86	NC
87	GND	88	GND
89	DDRCLK2	90	GND
91	DDRCLK2#	92	+2.5V
93	+2.5V	94	+2.5V
95	CKE3	96	CKE2
97	GND	98	GND
99	MAA12	100	MAA11
101	MAA9	102	MAA8
103	GND	104	GND
105	MAA7	106	MAA6
107	MAA5	108	MAA4
109	MAA3	110	MAA2
111	MAA1	112	MAA0
113	+2.5V	114	+2.5V

115	MAA10	116	MAA12
117	MAA11	118	SRAS#
119	SWE#	120	SCAS#
121	RCS0#	122	RCS1#
123	NC	124	NC
125	GND	126	GND
127	MD32	128	MD36
129	MD37	130	MD33
131	+2.5V	132	+2.5V
133	RDQS4	134	GND
135	MD34	136	MD38
137	GND	138	GND
139	MD35	140	MD39
141	MD40	142	MD44
143	+2.5V	144	+2.5V
145	MD41	146	MD45
147	RDQS5	148	GND
149	GND	150	GND
151	MD42	152	MD43
153	MD46	154	MD47
155	+2.5V	156	+2.5V
157	+2.5V	158	DDR_CLK1#
159	GND	160	DDR_CLK1
161	GND	162	GND
163	MD48	164	MD49
165	MD52	166	MD53
167	+2.5V	168	+2.5V
169	RDQS6	170	GND
171	MD50	172	MD54
173	GND	174	GND
175	MD51	176	MD55
177	MD57	178	MD56
179	+2.5V	180	+2.5V
181	MD61	182	MD60
183	RDQS7	184	GND
185	GND	186	GND
187	MD58	188	MD62
189	MD59	190	MD63

191	+2.5V	192	+2.5V
193	SMBDAT	194	GND
195	SMBCK	196	GND
197	+3VS	198	GND
199	NC	200	NC

JP18 Int. KB Interface CONN

PIN NO	SIGNAL	PIN NO	SIGNAL
1.	ID1	2.	ID2
3.	GND	4.	USER BTN#
5.	LED+	6.	LED-
7.	KSO0	8.	KSO1
9.	KSO2	10.	KSO3
11.	KSO4	12.	KSO5
13.	KSO6	14.	KSO7
15.	KSO8	16.	KSO9
17.	KSO10	18.	KSO11
19.	KSO12	20.	KSO13
21.	KSO14	22.	KSO15
23.	KSI0	24.	KSI1
25.	KSI2	26.	KSI3
27.	KSI4	28.	KSI5
29.	KSI6	30.	KSI7

JP20 Switch button Interface CONN

PIN NO	SIGNAL	PIN NO	SIGNAL
1.	+3VALW	2.	+3VS
3.	SCROLLLED#	4.	NUMLED#
5.	CAPSLLED#	6.	51ON#
7.	EC ACT#	8.	GND-MIC
9.	INT MIC	10.	GND-MIC
11.	USER BTN0#	12.	USER BTN1#
13.	USER BTN2#	14.	USER BTN3#
15.	GND	16.	NC
17.	NC	18.	NC
19.	NC	20.	GND

JP1 CPU FAN CONN.

PIN NO	SIGNAL	PIN NO	SIGNAL
1.	+5VFAN1	2.	FAN1_SPEED1
3.	GND		

JP14 RJ45-11 CONN.

PIN NO	SIGNAL	PIN NO	SIGNAL
1.	R	2.	R
3.	RX-	4.	R
5.	R	6.	RX+
7.	TX-	8.	TX+
9.	NC	10.	MOD TIP
11.	MOD RING	12.	NC
13.	GND	14.	GND
15.	LED1 GRNP	16.	LED GRNN
17.	LED2 YELP	18.	LED2 YELN

JP4 DDR 200P SO-DIMM

PIN NO	SIGNAL	PIN NO	SIGNAL
1.	MVREF_DIM	2.	MVREF_DIM
3.	GND	4.	GND
5.	MD0	6.	MD4
7.	MD1	8.	MD5
9.	+2.5V	10.	+2.5V
11.	RDQS0	12.	GND
13.	MD6	14.	MD3
15.	GND	16.	GND
17.	MD2	18.	MD7
19.	MD8	20.	MD12
21.	+2.5V	22.	+2.5V
23.	MD9	24.	MD13
25.	RDQS1	26.	GND
27.	GND	28.	GND
29.	MD10	30.	MD14
31.	MD15	32.	MD11
33.	+2.5V	34.	+2.5V
35.	DDR_CLK3	36.	+2.5V
37.	DDR_CLK3#	38.	GND
39.	GND	40.	GND
41.	MD16	42.	MD20
43.	MD21	44.	MD17
45.	+2.5V	46.	+2.5V
47.	RDQS2	48.	GND
49.	MD18	50.	MD22
51.	GND	52.	GND
53.	MD19	54.	MD23

55	MD24	56	MD28
57	+2.5V	58	+2.5V
59	MD25	60	MD29
61	RDQS3	62	GND
63	GND	64	GND
65	MD30	66	MD26
67	MD31	68	MD27
69	+2.5V	70	+2.5V
71	GND	72	GND
73	GND	74	GND
75	GND	76	GND
77	RDQS8	78	GND
79	GND	80	GND
81	+2.5V	82	+2.5V
83	GND	84	GND
85	NC	86	NC
87	GND	88	GND
89	DDRCLK5	90	GND
91	DDRCLK5#	92	+2.5V
93	+2.5V	94	+2.5V
95	CKE3	96	CKE2
97	GND	98	GND
99	MAA12	100	MAA11
101	MAA9	102	MAA8
103	GND	104	GND
105	MAA7	106	MAA6
107	MAA5	108	MAA4
109	MAA3	110	MAA2
111	MAA1	112	MAA0
113	+2.5V	114	+2.5V
115	MAA10	116	MAA12
117	MAA11	118	SRAS#
119	SWE#	120	SCAS#
121	RCS2#	122	RCS3#
123	NC	124	NC
125	GND	126	GND
127	MD32	128	MD36
129	MD37	130	MD33
131	+2.5V	132	+2.5V
133	RDQS4	134	GND
135	MD34	136	MD38

137	GND	138	GND
139	MD35	140	MD39
141	MD40	142	MD44
143	+2.5V	144	+2.5V
145	MD41	146	MD45
147	RDQS5	148	GND
149	GND	150	GND
151	MD42	152	MD43
153	MD46	154	MD47
155	+2.5V	156	+2.5V
157	+2.5V	158	DDR_CLK4#
159	GND	160	DDR_CLK4
161	GND	162	GND
163	MD48	164	MD49
165	MD52	166	MD53
167	+2.5V	168	+2.5V
169	RDQS6	170	GND
171	MD50	172	MD54
173	GND	174	GND
175	MD51	176	MD55
177	MD57	178	MD56
179	+2.5V	180	+2.5V
181	MD61	182	MD60
183	RDQS7	184	GND
185	GND	186	GND
187	MD58	188	MD62
189	MD59	190	MD63
191	+2.5V	192	+2.5V
193	SMBDAT	194	+3VS
195	SMBCK	196	GND
197	+3VS	198	GND
199	NC	200	NC

P15 MODEM CONN

PIN No	SIGNAL	PIN No	SIGNAL
1	MOD RING	2	MOD TIP

JP29 Audio M/B

PIN NO	SIGNAL	PIN NO	SIGNAL
--------	--------	--------	--------

1	CLK 14M SIO	2	GND
3	AC97 BCLK	4	HPLUG
5	AC97 RST#	6	AC97 SYNC
7	AC97 SDOUT	8	AC97 SDIN0
9	MD MIC	10	MONO IN
11	MOD AUDIO MONR	12	+3VS
13	CD AGND	14	CDROM L
15	CDROM R	16	GND MIC
17	INTMIC	18	GND
19	PS2 DATA	20	PS2 CLK
21	EC MUTE	22	FULL LED#
23	ACT LED#	24	CHARGING LED#
25	POWER1 LED#	26	POWER2 LED#
27	LED2	28	+5VS
29	+5VALW	30	+3VALW

JP16 MINI-PCI CONN

PIN No	SIGNAL	PIN No	SIGNAL
1.	NC	2.	NC
3.	NC	4.	NC
5.	NC	6.	NC
7.	NC	8.	NC
9.	NC	10.	NC
11.	NC	12.	NC
13.	D	14.	NC
15.	NC	16.	NC
17.	PIRQD#	18.	+5VS
19.	+3VS	20.	PIRQB#
21.	REQ#4	22.	GNT#4
23.	GND	24.	+3.3VAUX
25.	PCLK MINI	26.	PCIRST#
27.	GND	28.	+3VS
29.	REQ#1	30.	GNT#1
31.	+3VS	32.	GND
33.	AD31	34.	MINI PME#
35.	AD29	36.	LAN PME#
37.	GND	38.	AD30
39.	AD27	40.	+3VS
41.	AD25	42.	AD28
43.	LAN IDSEL	44.	AD26
45.	CBE#3	46.	AD24

47.	AD23	48.	MINI IDSEL
49.	GND	50.	GND
51	AD21	52	AD22
53	AD19	54	AD20
55	GND	56	PAR
57	AD17	58	AD18
59	CBE#2	60	AD16
61	IRDY#	62	GND
63	+3VS	64	FRAME#
65	CLKRUN#	66	TRDY#
67	SERR#	68	STOP#
69	GND	70	+3VS
71	PERR#	72	DEVSEL#
73	CBE#1	74	GND
75	AD14	76	AD15
77	GND	78	AD13
79	AD12	80	AD11
81	AD10	82	GND
83	GND	84	AD9
85	AD6	86	CBE#0
87	AD7	88	+3VS
89	+3VS	90	AD6
91	AD5	92	AD4
93	NC	94	AD2
95	AD3	96	AD0
97	+5VS	98	NC
99	AD1	100	NC
101	GND	102	GND
103	AC97 SYNC	104	NC
105	AC97 SDIN1	106	AC97 SDOUT
107	AC97 BCLK	108	NC
109	+3.3VAUX	110	AC97 RST#
111	MOD AUDIO MON	112	NC
113	GND	114	GND
115	MD MIC	116	MD AUDIO MON
117	GND	118	GND
119	GND	120	GND
121	MODEM RI#	122	NC
123	+5VS	124	+3.3VAUX
127	GND	129	GND

JP7 TV-OUT CONN

PIN No	SIGNAL	PIN No	SIGNAL
1	GND	2	LUMA
3	GND	4	CRMA
5	GND	6	
7	COMPS		

JP8 PANEL CONN

PIN No	SIGNAL	PIN No	SIGNAL
1.	LCDVDD	2.	LCDVDD
3.	DC2	4.	GND
5.	TX0-	6.	TX0+
7	GND	8.	TX1-
9.	TX1+	10.	GND
11.	TX4-	12.	TX4+
13.	GND	14.	TXBCLK-
15.	TXBCLK+	16.	GND
17.	PID3	18.	PID2
19.	PID1	20.	PID0
21.	TX2-	22.	TX2+
23.	GND	24.	TCACLK-
25.	TXACLK+	26.	GND
27	TX5-	28	TX5+
29.	GND	30.	TX6-
31.	TX6+	32.	GND
33.	DD2	34.	LCDVDD
35.	LCDVDD	36.	DAC BRIG
37	INVT PWM	38	DISPOFF#
39.	B+	40.	B+

JP30 CARD READER CONN

PIN No	SIGNAL	PIN No	SIGNAL
1	+5VS	2	+5VS
3	USB5 D+	4	USB5 D-
5	PCIRST#	6	GND

JP11 1394 CONN

PIN No	SIGNAL	PIN No	SIGNAL
1	XTPA0+	2	XTPA0-
3	XTPB0+	4	XTPB0-

Chapter 4: AC-DC CONVERTER

ACY25 series Power System block diagram

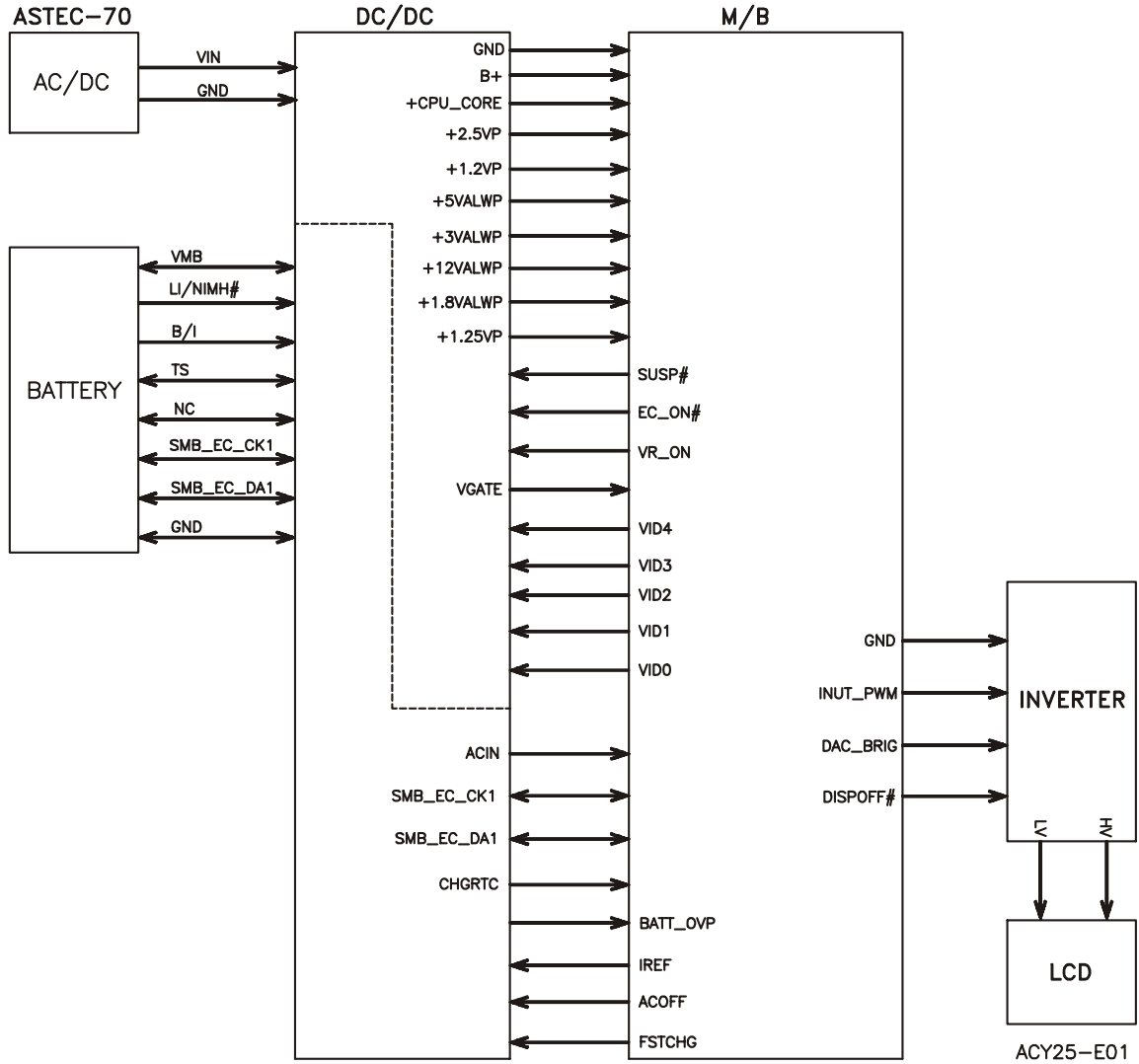

Description

This specification defines the performance and characteristic ASTEC SA80-3105-2278 AC adapter power supply. It supplies a constant voltage 19V output source for ACY25 series notebook computer.

Feature

Accepts universal input from 90V_{AC} to 265V_{AC}

Offers constant Voltage 19.5V output source with 70W max output power capacity.

High efficiency 84% typical after burn in one hour

Compact Size

Electrical Specification

Input Voltage range: *universal input, 90V_{AC} TO 265V_{AC}*

Inrush current: *188A_{pk} MAX @240V_{AC} (cold start)*

Input frequency range: *47~63Hz*

Input Current: *1.2A_{max} at 90V_{AC}, 70W LOAD*

Start-up time: *≤3sec at all line and load condition*

HOLD-UP time: *≥10m sec at 120V_{AC}.full load condition*

OUTPUT Voltage Regulation: *18.5V~20V including the effects of line Voltage variation, load current, ripple and noise*

OUTPUT Current: *0A_{min}, 3.68A_{max} continuous*

OUTPUT Voltage ripple: *≤300mV PK-PK for resistor load*

OUTPUT Voltage Dynamic regulation: *Output change between 0A and 3.51A, Applied at 100Hz with 50% duty cycle at 0.5A/us slew Rate. Voltage overshoot<0.5V.*

DC OUTPUT PIN OUT:

Adapter power return

Adapter power + output.

AC SOCKET : 2PIN (L,N,FG) 2.5A 250V UL : 94V-0.

Temperature Range:

Operating temperature: +5°C TO 40°C

Storage temperature: -100°C TO +70°C

DC-DC CONVERTER

Description

The DC-DC converter is designed to supply the power for ACY25 series notebook computer of Compal. It supply +5VALWP, +3VALWP, +1.8VALWP, +2.5VP, +CPU_CORE, +1.25VP,+1.2VP for logical system, and supplies for the built-in NS87591 microprocessor which handles the keyboard and PMU control functions of the system. The power ON/OFF is also controlled by NS87591. There is also a charger power source built-in it. It can charge battery pack whether the computer is ON or OFF.

Features

High efficiency, up to 90%(using battery)

Accept wide range DC input voltage from 8V to 21V

Built-in charger power source

The power ON/OFF is controlled by software

Electrical specification

Input Voltage/Current

10V to 20V at the summing point of AC Adapter and battery

INPUT Current 5A max from battery

INPUT Current 3.5A max from AC Adapter

Temperature Range:

Operating temperature : 0°C to 40°C

storage temperature range : -20°C to 65°C

DC/DC OUTPUT

Fixed output voltage/Current

Item	+5VALWP	+1.25VP	+1.2VP
nominal voltage	+5V	+1.25V	+1.2V
min. load	0A	0A	0A
max. load	4A	2A	0.2A
peak load	5.5A	3A	0.3A
total regulation	5V±5%	2% static 4% transient	5%
ripple voltage	100mVp-p max.	25mVp-p max.	60mVp-p max.
Item	+12VALWP	+3VALWP	+1.8VALWP
nominal voltage	+12V	+3.3V	+1.8V
min. load	0A	0A	0A
max. load	120mA	4A	1.5A
peak load	200mA	6A	2.5A
total regulation	12V±5%	3.3V±5%	1.8V±5%
ripple voltage	200mVp-p max.	100mVp-p max.	60mVp-p max.
Item	+CPU_CORE	+2.5VP	
Nominal voltage	Base on table1	+2.5V	
Min load	0mA	0mA	
Max load	32A	4A	
Peak load	40A	6A	
Total regulation	-2mV/A with +-45mV	5%	
Ripple voltage	60mVp-p max.	60mVp-p max.	

Table 1

VID[4..0]	+CPU_CORE P	VID[4..0]	+CPU_CORE P	VID[4..0]	+CPU_CORE P	VID[4..0]	+CPU_CORE P
00000	1.75	01000	1.35	100000	0.975	11000	0.775
00001	1.70	01001	1.30	10001	0.950	11001	0.750
00010	1.65	01010	1.25	10010	0.925	11010	0.725
00011	1.60	01011	1.20	10011	0.900	11011	0.700
00100	1.55	01100	1.15	10100	0.835	11100	0.675
00101	1.50	01101	1.10	10101	0.850	11101	0.650
00110	1.45	01110	1.05	10110	0.825	11110	0.625
00111	1.40	01111	1.00	10111	0.800	11111	0.600

Charger

Controlled by NS87591 microprocessor from motherboard

Temperature sense capability for the battery (charge active between 0°C~ 40°C)

fast charge [2.5Amps-8cells(3900mAH), Lilon Battery when system off, approach 30W fast charge when system ON.(depend on system load)

Charging termination: check the Full_charged bit in Battery status of Smart Battery.

When system turns off, the charging time from empty to full is 3.0 hrs typically at room temperature.

Other battery services are presented by NS87591 microprocessor include maximum charging timer, charging temperature range etc.

Charger power:

BATT++ Constant voltage mode: 16.8V±1%

Constant charger current mode:2.5A±10%-8cells(3900mAH)

Constant adapter current mode:3.20A±10%

OVER Current protection:

+5VALWP: 5.67~9.17A

+3.3VALWP: 5.23~8.73A

+CPU_CORE: 40~60A

OVER Voltage protection:

+5VALWP: $V_0+V_0*(4\sim10\%)$

+3.3VALWP: $V_0+V_0*(4\sim10\%)$

+CPU_CORE: $V_0+V_0*12\%$

Short circuit protection:

latch mode for +5VALWP, +3VALWP, +CPU_CORE

auto recovery mode for +12VALWP

I/O

P1:Ac adapter input Jack socket

Pin 1: Adapter power return

Pin 2: Adapter power + input

DC/DC Interface

DC/DC			
Signals	I/O	Voltage Level	Description
EC_ON#	I	0~floating	Active Low, NS87591 use this pin to control the system power on/off.
ACOFF	I	0~3.3V	Active High, turn off the adaptor power for battery automatic learning cycle.
ACIN	O	0~3.3V	Active High, go high when adaptor plug-in.
VGATE	O	0~3.3V	Active High, go high when +CPU_CORE ready.
VR_ON	I	0~3.3V	Active High, turn on/off the +CPU_CORE, +1.2VP
VID[0..4]	I	0~3.3V	CPU VID
FSTCHG	I	0~3.3V	Active High, NS87591 use this pin to enable charger.
IREF	I	0~3.3V	NS87591 DAC output, it control the charging current.
SMB_EC_CK1	I/O	0~5V	SMBus Clock.
SMB_EC_DA1	I/O	0~5V	SMBus data.
BATT_TEMP	O	0~3.3V	Battery Temperature detect pin
SUSP#	O	0~3.3V	Active High, NS87591 use this pin to suspend system

BATTERY

Lithium-Ion battery for ACY25 series

18650 2P4S, 14.8V/3900mAH, Lithium-Ion battery

Built-in protection and gas gauge function.

More than 300 charging/discharging cycles.

Modularized battery pack, easy to be replaced.

On board RTC battery: Maxell ML1220/1FC 3V/14mAH Lithium or Sanyo ML1220-TT28 3V/15mAH Lithium

ACY25 14.1” & 15” INVERTER SPECIFICATION

General Description

There are two control signals that come from system to control lamp brightness. One signal is named DAC_BRIG, which limits current to meet LCD lamp current specification. Another one is named PWM, which adjusts lamp brightness. This inverter brightness is adjusted by PWM burst mode. The PWM burst mode is that turning on and off the lamp at a rate of 150Hz. The effective brightness is a function of the duty cycle.

Features

- Wide range 9V to 21V input voltage
- Brightness adjustment by PWM burst mode.
- Close loop controls lamp current.

Absolute maximum rating

Environment: Temperature:

Operating temperature: 0°C ~ 55°C

Storage temperature : -20°C ~ 70°C

Humidity: 0 ~ 90% without condensation

MTBF: 50000 hours.

Electrical characteristic

No	Item	Symbol	Min.	Typ.	Max.	Unit	Comment
1	Input voltage	INV_PWR	9	14.8	21	V	
2	Input current	Iin	--	0.33	--	A	
3	Lamp current	I _L	2.7	--	6.3	mA	*Note 1
4	Frequency	F	45	55	65	KHz	*Note2
5	Output power	Pout	--	--	4.5	W	
6	Efficiency	η	80%	--	--	--	
7	Starting voltage	V _s	1600	--	--	V	At 0°C
8	Starting time	T _{vs}	1	--	1.5	Sec	
9	Dispoff#		2.8	3.3	3.6	V	Backlight on/off signal
			0	0.5	0.8	V	Low level
10	Limited lamp maximum current	DAC-BRIG	0		3.3	V	*Note 1

11	PWM signal *note 4	INV_PWM	142	150	158	Hz	PWM signal frequency
			3.0	3.3	3.6	V	PWM signal amplitude
			30	--	100	%	$Duty = \frac{T_{on}}{Period}$
12	lamp current over-shoot	$I_{Zero-PK}$	--	--	10	%	Line transient(10.8V to 21V/100us) and turn on transient
13	Current Waveform factor	$\frac{I_p}{I_{rms}}$	1.27	$\sqrt{2}$	1.56	Multiple	OR $\frac{I_{-p}}{I_{rms}} *10$
14	Unbalance Rate	$\frac{I_p - I_{-p} }{I_{rms}}$	-10%	0	+10%	Multiple	
15	Turn off voltage	Voff	--	--	100Vp-p	V	PWM=40%
16	Voltage Rise time	Trise	--	--	300us	us	PWM=40%
17	Voltage fall time	Tfall	--	--	300us	us	PWM=40%

Notes:

- *1. Limited lamp maximum current by DAC_BRIG signal:
When DAC_BRIG voltage is 0V and INV_PWM enables (100%), lamp has max. limited current.
When DAC_BRIG voltage is 3.3V and INV_PWM enables (100%), lamp has min. limited current.
DAC_BRIG signal comes from system chipset with internal resistance of 3K Ω .
- *2. Inverter operating frequency should be within specification (45~65kHz) at max. and min. brightness load.
- *3. INV_PWM enable implies INV_PWM signal is High level (On duty cycle is 100%). It is a square wave of 150Hz to adjust backlight brightness that is a function of PWM duty cycle. Backlight brightness is maximum value under INV_PWM at 100% and brightness is minimum under INV_PWM at 40%.
- *4. The system interface signals belong to 3.3V.
- *5. Please make sure open lamp output voltage should be within starting voltage specification.
- *6. Inverter should pass human body safety test.
- *7. Inverter should no smoking by any component open/ short test
- *8. Transformer voltage stress should not be over 85% under any condition
(turn on overshoot transient and line transient).
- *9. Audio noise should be less than 36dB at 10 cm distance.

Electrical specification

No	Symbol	Min.	Typ.	Max.	Unit	Comment
1	V _{oper.}	--	700	--	Vrms	Lamp operating voltage
	I _L	5.7	6.0	6.3	mArms	DAC_BRIG: 0 V, PWM: 100%
	I _L	2.7	3.0	3.3	mArms	DAC_BRIG: 0 V, PWM:30%
	F	45	55	65	KHz	
	η	80%	--	--	--	

Thermal

All components on inverter board should follow below rules:

Component using conditions (component stress) must be within component specification including voltage rating, current rating, temperature etc.

Component temperature should follow below:

- $\Delta T < 30^{\circ}\text{C}$, at 25 , 35 $^{\circ}\text{C}$.
- Component temperature should be less than 70 $^{\circ}\text{C}$ inside system at 35 $^{\circ}\text{C}$.

Connector description

Input Connector:

CN1: ACES 87213-0700; JST SM07B-SRSS-TB

Pin No.	Symbol	Description
1	INV_PWR	Input voltage (9V-21V)
2	INV_PWR	Input voltage (9V-21V)
3	INV_PWM	Adjust brightness by burst mode(3.3 V 150Hz)
4	DISOFF #	Backlight on/off control, active HIGH(3.3V)
5	DAC_BRIG	Max. current limit
6	GND	Power system return
7	GND	Power system return

Output Connector:

CN2: JST_SM02B_BHSS-1

Pin No.	Symbol	Description
1	HV	Connected to high voltage of LCD lamp
2	LV	Connected to low voltage of LCD lamp

Note : Please mark " CAUTION HIGH VOLTAGE" around CN2

Safety Protection

Open lamp protection:

When inverter is on open lamp status, any component on inverter should be O.K and inverter is no damaged, no fire and no arcing. If inverter can't shunt down during open lamp happen, inverter must pass below conditions:

Human body test.

Open lamp burning: Inverter burns for 24 hours at open lamp status. No parts damage.

Human body safety test:

Short inverter output, transformer secondary output to GND by a $2K\Omega$ resistor which connects one end to GND and another one to those outputs. They should meet output current limitation requirement as follow. Output current I is the current that flows through $2K\Omega$ resistor.

Output current $I \leq 0.7\text{mA}$, if frequency $f \leq 1\text{KHz}$

Output current $I \leq 0.7\text{mA} * f$ (kHz) , if $f \geq 1\text{KHz}$.

However, output current should be less than 70mA even frequency is more than 100KHz.

Abnormal test:

Any one component is short or open; inverter should be no fire, no arcing. And result must meet output current limitation requirement.

Chapter 5: Disassembly

General

This chapter provides detailed directions for disassembling the computer. You will require a medium size screwdriver, small screwdriver and a 6mm nut driver (for the helix screw nuts on the rear ports).

Before starting to disassemble the computer, refer to the diagram below. This indicates which modules need to be removed to access the module needing replacement. Always start by removing the battery pack. Then work down through the diagram, removing only those modules necessary to reach the module to be replaced.

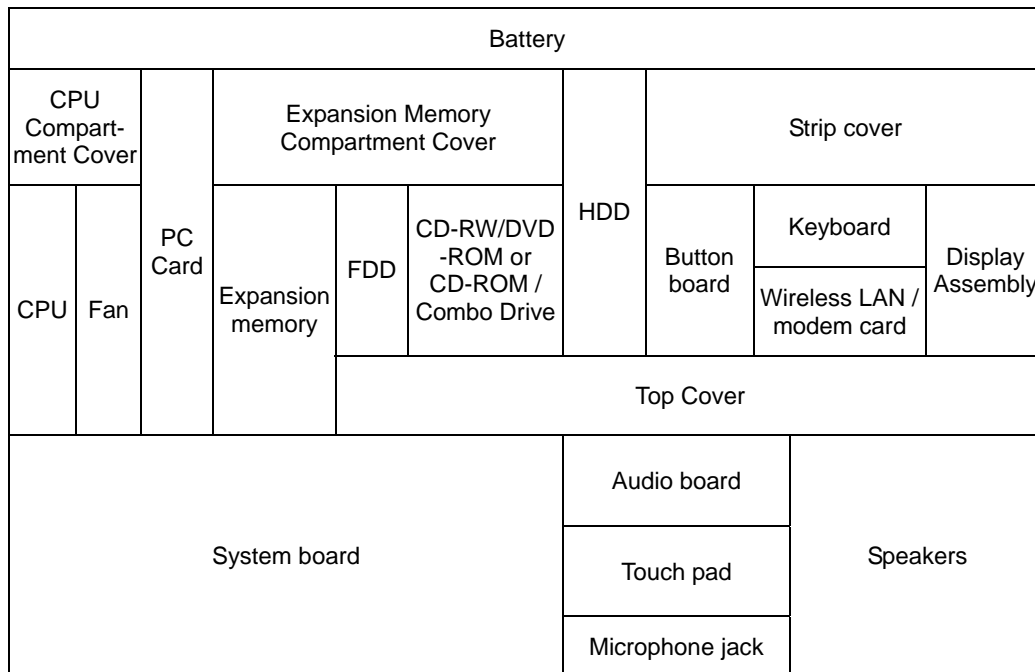

The example below shows which modules need to be removed before the audio board can be removed and repaired or replaced. The audio board is overlapped by the top cover, which must be removed before the audio board can be reached. The top cover is in turn overlapped by several other units (shaded gray) and these must be removed before the top cover can be reached. Always starts the disassembly process by removing the battery.

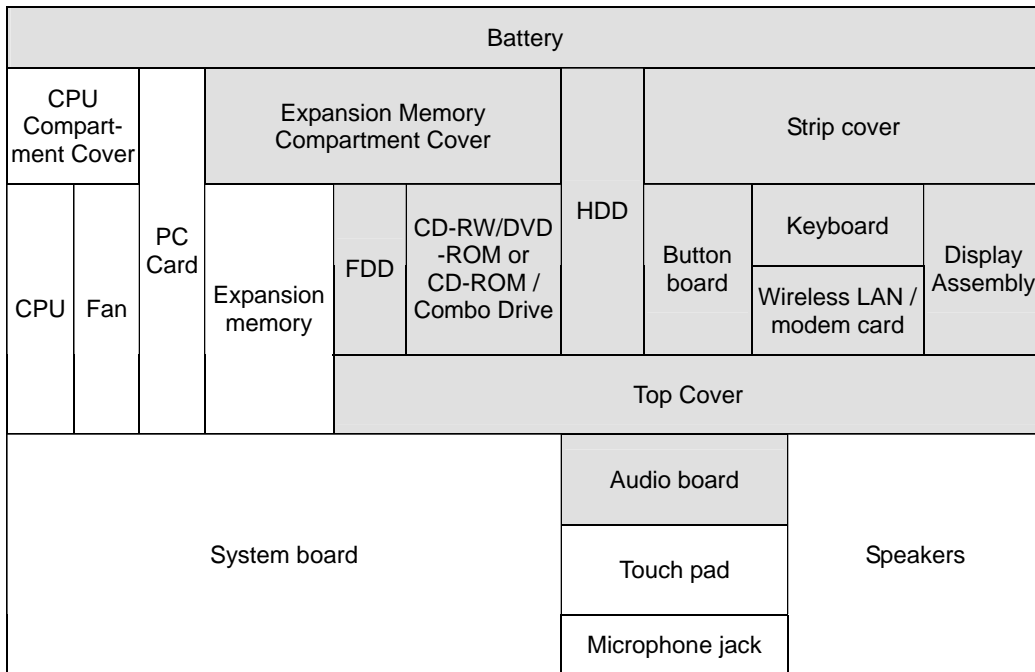

Safety Precautions

Before you begin disassembly, read the following safety precautions and observe them carefully as you work.

DANGER:

1. *Always use the lithium ion battery pack or backup battery that is authorized by the manufacturer or compatible with the unit. Since other battery packs have different specifications, they may be incompatible with the unit, and may burst or explode. Heating or disassembling the battery pack could cause leakage of alkaline solution. Throwing the battery pack into a fire could cause the battery pack to explode.*
2. *The power supply, FL inverter and other components carry high voltages. To avoid the risk of electric shock when you need to turn on the power of a partially disassembled computer to check its operation, be very careful not to touch connectors or components. Also, do not disassemble individual components in first-level maintenance.*

WARNING: To avoid the risk of electric shock or other injury:

1. *Always turn the power off and disconnect the AC adaptor from the power source.*
2. *Remove any metal jewelry or accessories such as necklaces, bracelets, or rings. Batteries in the computer retain an electrical charge so there is danger of electrical shock even when the computer is disconnected from an AC power source.*
3. *Never work with wet or damp hands.*
4. *The computer contains sharp edges and corners: be careful not to injure yourself.*
5. *Make sure that all replacement components meet the specifications for the computer and that all cables and connectors are securely fastened.*

CAUTION: To avoid damage to the computer:

1. *When you change a component, be sure the replacement component meets the required specifications. Never use foreign parts.*
2. *Metal objects such as screws or paper clips which fall into the unit can cause a short-circuit, fire, or other internal damage.*
3. *When assembling the computer, make sure you use the correct screws to secure the various pieces in place. Screw sizes are listed in their corresponding figure. Make sure all screws are securely fastened. Loose screws can cause short circuits, resulting in heat, smoke, or fire.*
4. *Before removing an module or other component, make sure all cables to the component have been disconnected.*
5. *If you use AC power, be sure to use the cable that came with the computer or one recommended by the manufacturer.*

Before You Begin

Look over the procedures in this section before you begin disassembling the computer. Familiarize yourself with the disassembly and reassembly steps. Begin each procedure by removing the AC adaptor and the battery pack.

1. Do not disassemble the computer unless it is operating abnormally.
2. Use only the correct and approved tools.
3. Make sure the working environment is free from the following elements whether you are using or storing the computer.
 - ⇒ Dust and contaminants
 - ⇒ Static electricity
 - ⇒ Extreme heat, cold and humidity
4. Do not perform any operations that are not necessary and use only the described procedures for disassembling and installing modules in the computer.
5. After removing parts from the computer, place them in a safe place away from the computer so they will not be damaged and will not interfere with your work.
6. You will remove and replace many screws when you disassemble the computer. When you remove screws, make sure they are placed in a safe place and identified with the correct parts.
7. When assembling the computer make sure you use the correct screws to secure the various pieces. Screw sizes are listed in their corresponding figures.
8. The computer contains many sharp edges and corners, so be careful not to injure yourself.
9. After you have replaced a component, make sure the computer is functioning properly by performing the appropriate test on the component you have fixed or replaced.

Disassembly Procedures

The computer has two basic types of cable connectors:

- Pressure Plate Connectors
- Standard Pin Connectors

To disconnect a Pressure Plate connector, lift up the tabs on either side of the connector's plastic pressure plate and slide the cable out of the connector. To connect the cable to a Pressure Plate connector, make sure the pressure plate is fully lifted and slide the cable into the connector. Secure the cable in place by pushing the sides of the pressure plate down so the plate is flush with the sides of the connector. Gently pull on the cable to make sure the cable is secure. If you pull out the connector, connect it again making sure the connector's pressure plate is fully lifted when you insert the cable.

Standard pin connectors are used with all other cables. These connectors can be connected and disconnected by simply pulling them apart or pushing them together.

Assembly Procedures

After you have disassembled the computer and fixed or repaired the problem that was causing the computer to operate abnormally, you will need to reassemble the computer.

While assembling the computer, remember the following general points:

- Take your time. Most problems arise when you get in a hurry assembling the computer.
- Make sure all cables and connectors are securely fastened.
- Before securing the module or other parts, make sure that no cables will be pinched by screws or the module.
- Check that all latches are closed securely.
- Make sure all the correct screws are used to secure all components. Using the wrong screw can either damage the threads on the screw or the head of the screw and may prevent proper seating of a module.

After installing a component in the computer, confirm that the component and the computer are functioning properly.

Tools and Equipment

The use of Electrostatic Discharge (ESD) equipment is very important for your safety and the safety of those around you. Proper use of these devices will increase the success rate of your repairs and lower the cost for damaged or destroyed parts. The following equipment is necessary to disassemble and reassemble the computer:

- One medium size screwdriver
- One small screwdriver
- One 6mm nut driver (for the helix screw nuts on the rear ports)
- Tweezers, to lift out screws that you cannot grasp with your fingers.
- ESD mats for the floor and the table you are working on.
- ESD wrist strap or heel grounder.
- Anti-static carpeting or flooring.
- Air-ionizers in highly static sensitive areas.

Battery

1. Place the computer upside down with the front facing toward you.
2. Press the battery release button down and slide the battery latch to the right.
3. The battery pack will pop up slightly. Lever it out by easing up the protruding edge.



Figure 5-1: Removing the battery

PC Card

1. Push the eject button for the card you want to release. The button will pop out when you release it.



Figure 5-2: Ejecting a PC card (1/2)

2. Push the eject button once more to pop the PC Card out slightly.
3. Grasp the PC Card and remove it.
4. Push the eject button back into place, if necessary.



Figure 5-3: Ejecting a PC card (2/2)

Display Assembly

The instructions and figures below are for the 15" display. Differences with the 14" display are indicated where necessary.

Removing the display assembly

1. Remove two M2.5x5 screws securing the strip cover.



Figure 5-4: Removing two screws securing the strip cover

2. Open the display fully so that the display and computer are flat on the table.
3. Insert the end of a small screwdriver between the strip cover and one of the display assembly hinges. Gently pry off the strip cover.



Figure 5-5: Removing the strip cover

4. Lever the LCD display wire set connector off the system board connector. Do not pull on the wire itself as this may cause damage. Instead, pull on the connector white wire set connector.
5. Remove two M2.5×5 screws securing the display assembly hinges.

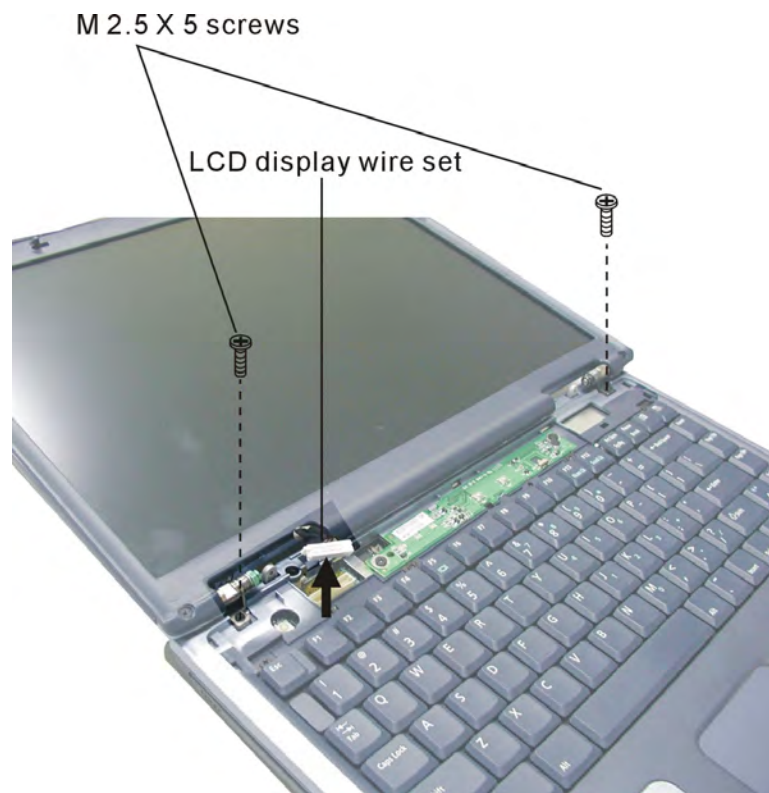

Figure 5-6: Releasing the LCD display wire set and hinges

6. Turn the computer over. Remove two M2.5×9 screws from the base and two M2.5×7 screws from the rear panel.



Figure 5-7: Removing two screws securing the display assembly

7. Turn the computer upright. Open the display so that it is perpendicular to the desk, then gently lift off the display.



Figure 5-8: Lifting off the display assembly

Disassembling the display assembly

1. Remove two mask seals and two M2.5×7 screws securing the LCD bezel. If disassembling the 14" display, two M2.5×5 screws must also be removed from the top of the LCD bezel.

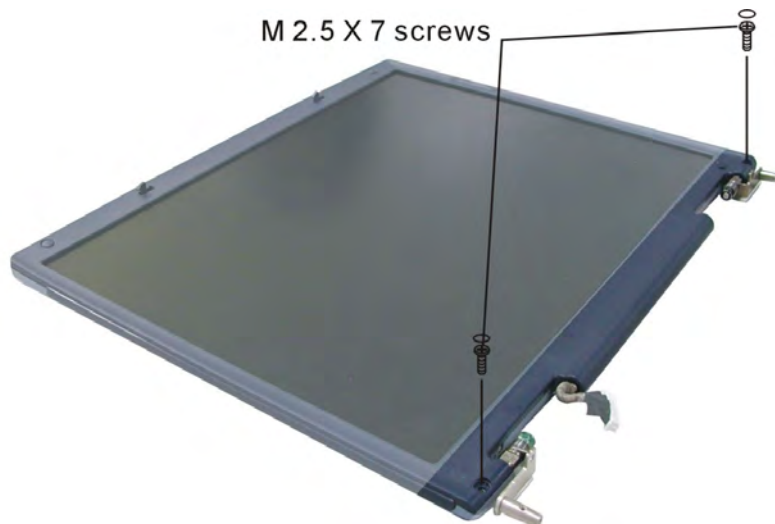

Figure 5-9: Removing two screws securing the LCD bezel

2. Ease the bezel off the display, starting from one of the sides. The bezel is secured by latches, with four on each of the sides, seven along the bottom edge and six along the top edge.



Figure 5-10: Removing the LCD bezel

3. Remove the following eight screws securing the LCD module in the LCD cover:
 - ⇒ Two M2×3 screws from each side
 - ⇒ Two M2.5×5 screws from the upper corners
 - ⇒ Two M2.5×5 screws from the bottom corners

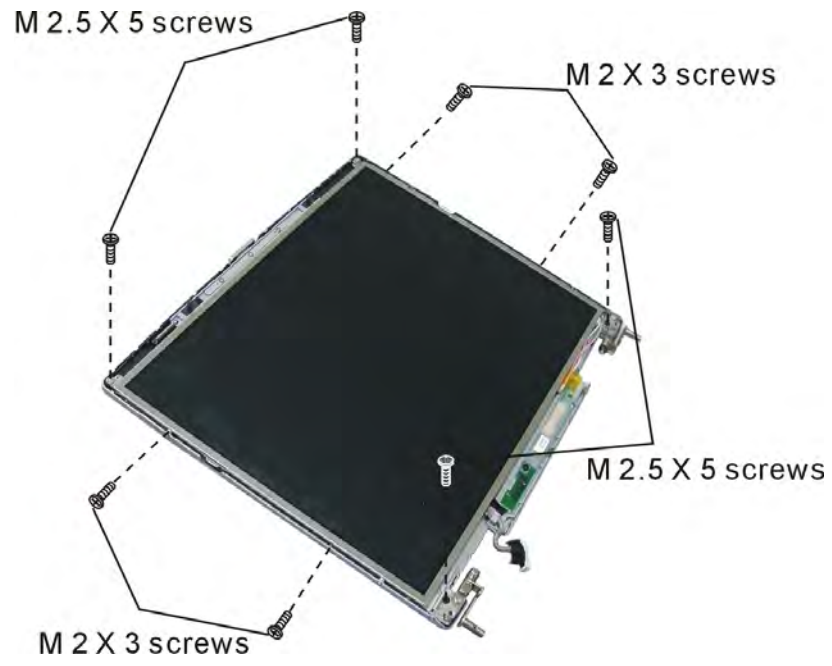

Figure 5-11: Removing eight screws securing the LCD module

4. Lift the LCD module out of the LCD cover.

5. Release the LCD cable from its hook to the left of the FL inverter board.
6. Detach the HV cable from the right of the FL inverter board.



Figure 5-12: Detaching the FL inverter board

7. Remove one M2.5×3 screw securing the FL inverter board.
8. Gently lift out the FL inverter board and detach the FL FPC from its left-hand end.



Figure 5-13: Detaching the FL FPC

9. Remove the LCD array and place face down.
10. Remove two pieces of tape sticking the LCD cable to the LCD array.
11. Detach the LCD cable from its connector

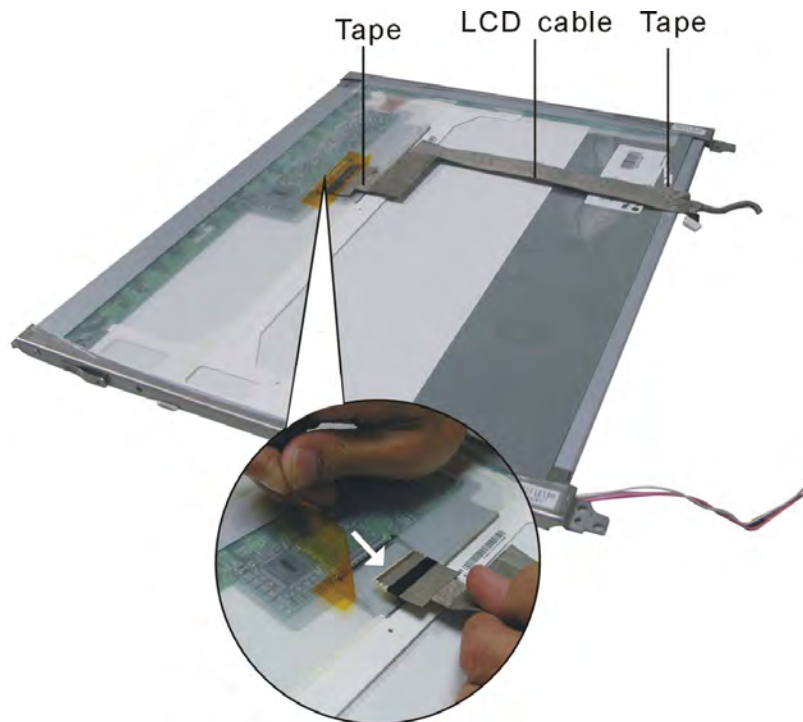

Figure 5-14: Removing the LCD cable

12. Remove six M2×2.5 screws securing the LCD bracket to the LCD module (the 14" LCD module is secured by four screws).

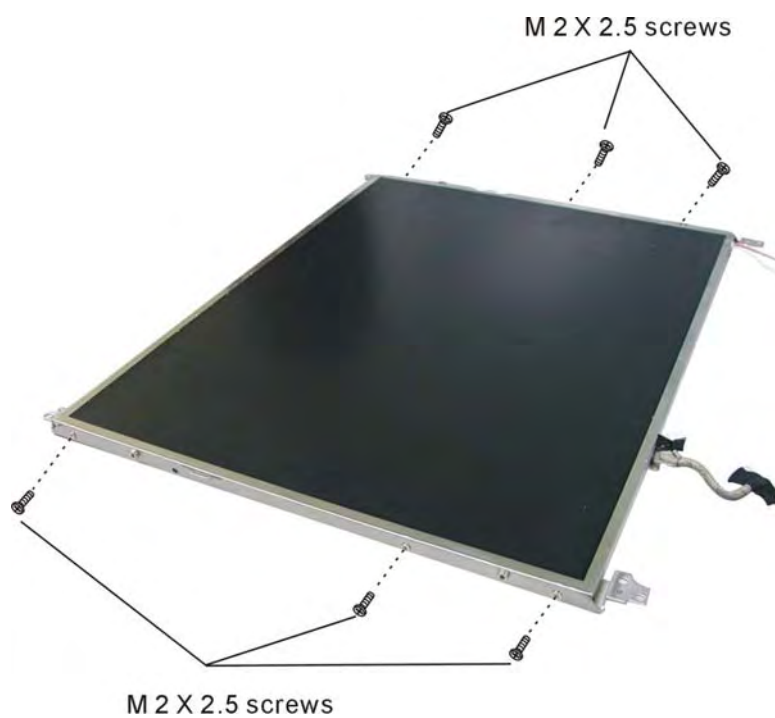

Figure 5-15: Removing the LCD bracket

Keyboard / button board

- 1. Remove four M2.5x3 screws securing the keyboard.



Figure 5-16: Removing four screws securing the keyboard

2. Lift the keyboard up and place higher on the computer base unit so that the keyboard cable connector is exposed.
3. Detach the keyboard cable and remove the keyboard.



Figure 5-17: Removing the keyboard

4. Remove two M2.5×3 screws securing the button board. Remove the button board.

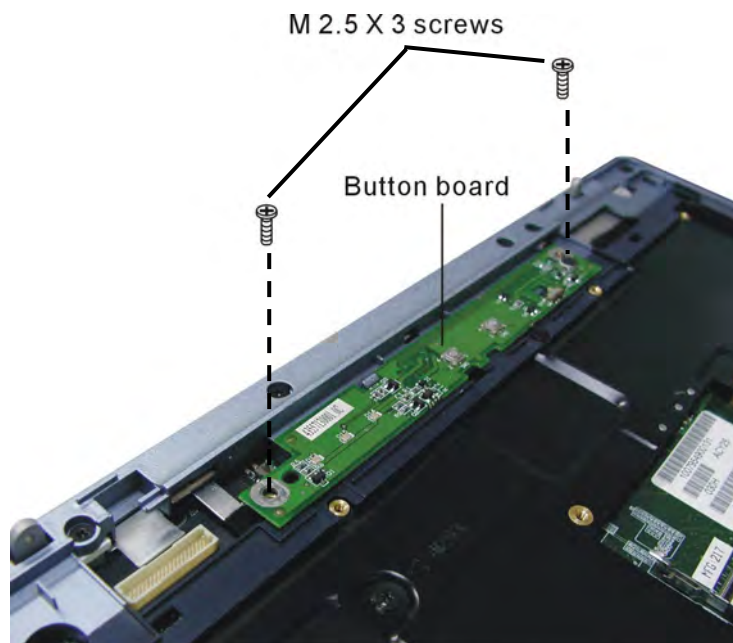

Figure 5-18: Removing the button board

Wireless LAN / Modem Unit

1. Remove two M2.5×3 screws securing the wireless LAN card compartment cover.
Remove the cover.

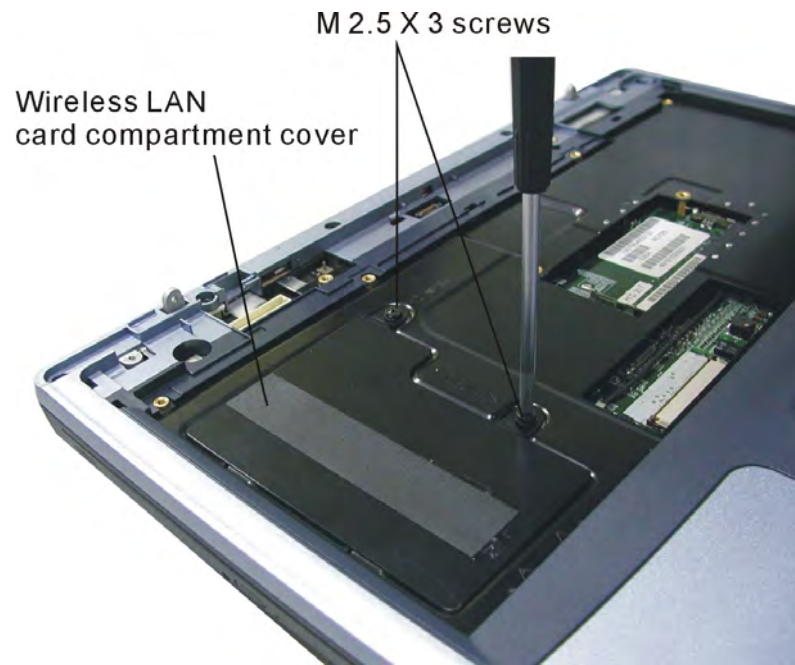

Figure 5-19: Removing the Wireless LAN compartment cover

2. Disconnect the modem cable.
3. If you will subsequently remove the top cover, you should peel back the tape covering the Touch pad FFC and detach the FFC from its connector. If your aim is solely to remove the Wireless LAN / modem card you do not need to detach the FFC.

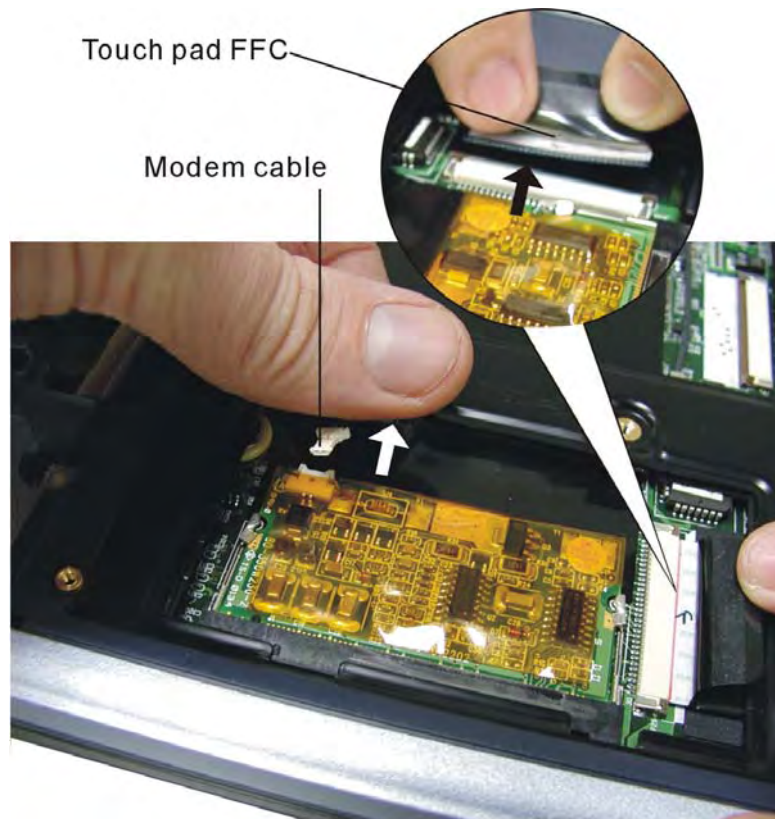

Figure 5-20: Disconnecting the Wireless LAN / modem card

4. Push out the two latches securing the wireless LAN /modem card. One end of the card will pop up.
5. Grasp the wireless LAN /modem card and pull it out.

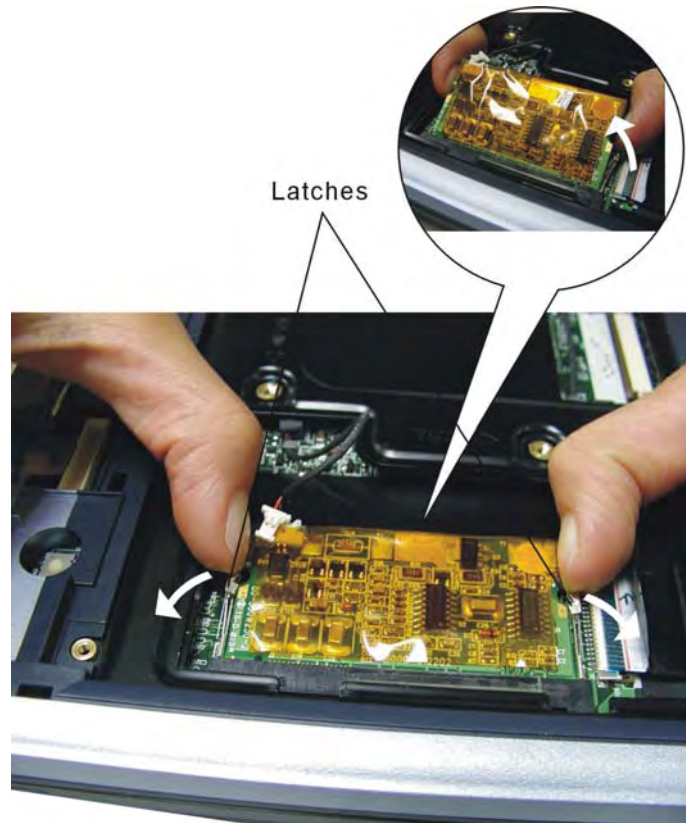

Figure 5-21: Removing the Wireless LAN / modem card

Expansion Memory

1. Remove one M2.5×5 screw securing the expansion memory compartment cover.
Lift off the cover.

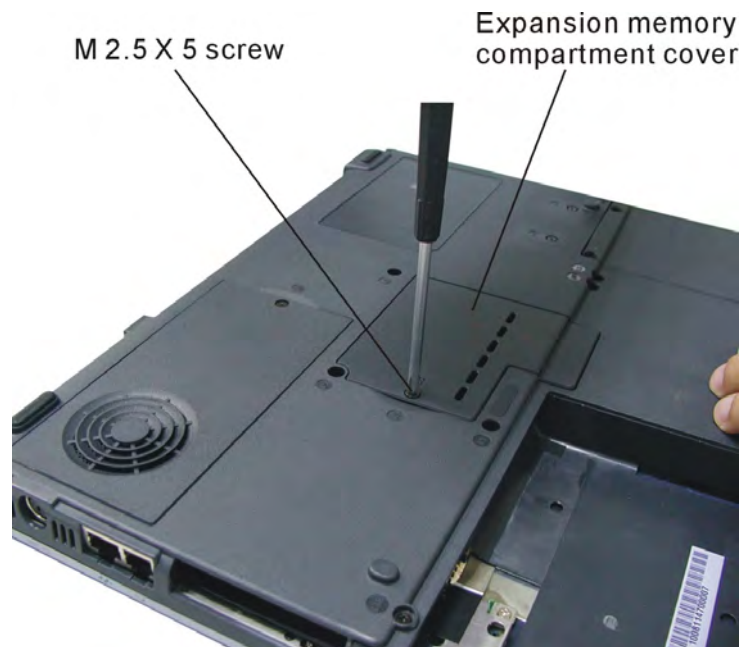

Figure 5-22: Removing one screw securing the expansion memory compartment cover

2. Gently press out the latches securing the expansion memory. One end of the memory will pop up.
3. Grasp the expansion memory and pull it out.

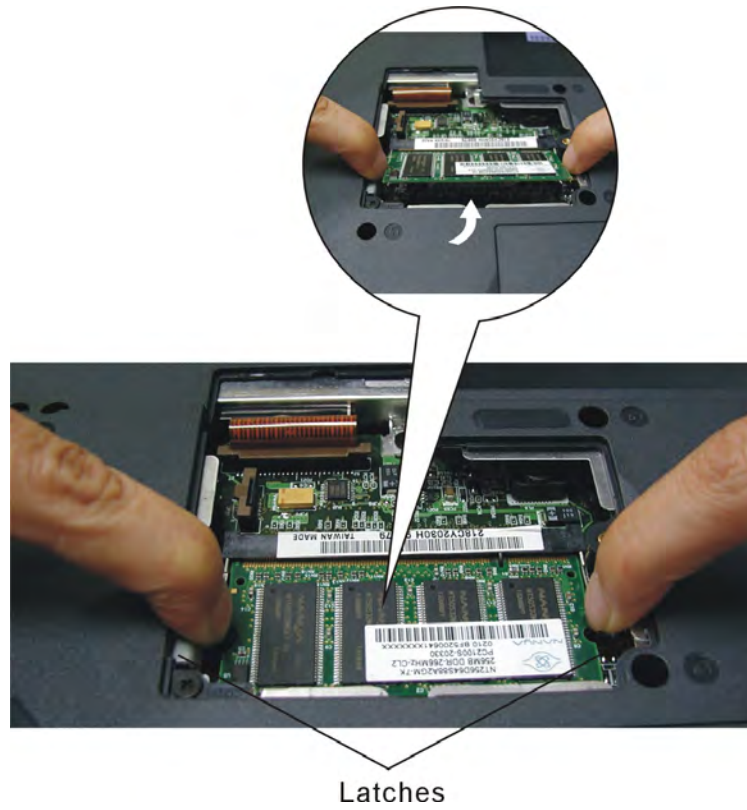

Figure 5-23: Removing the expansion memory

4. A spare expansion memory slot is located beneath the keyboard. To access this remove the keyboard following the instructions in section 4.5. Remove the memory card in the same way by easing the two latches apart.

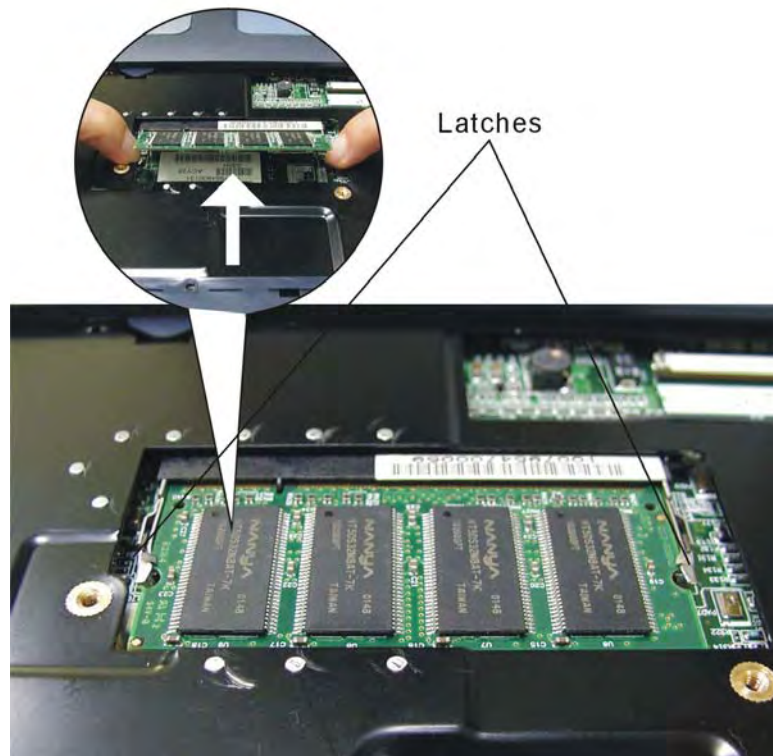

Figure 5-24: Removing the spare expansion memory

CD-RW/DVD-ROM or CD-ROM/Combo Drive

1. Remove one M2.5×5 screw securing the expansion memory compartment cover (see section 4.7). Lift off the cover.
2. Remove one M2.5×7 screw securing the CD-RW/DVD-ROM or CD-ROM/Combo Drive.

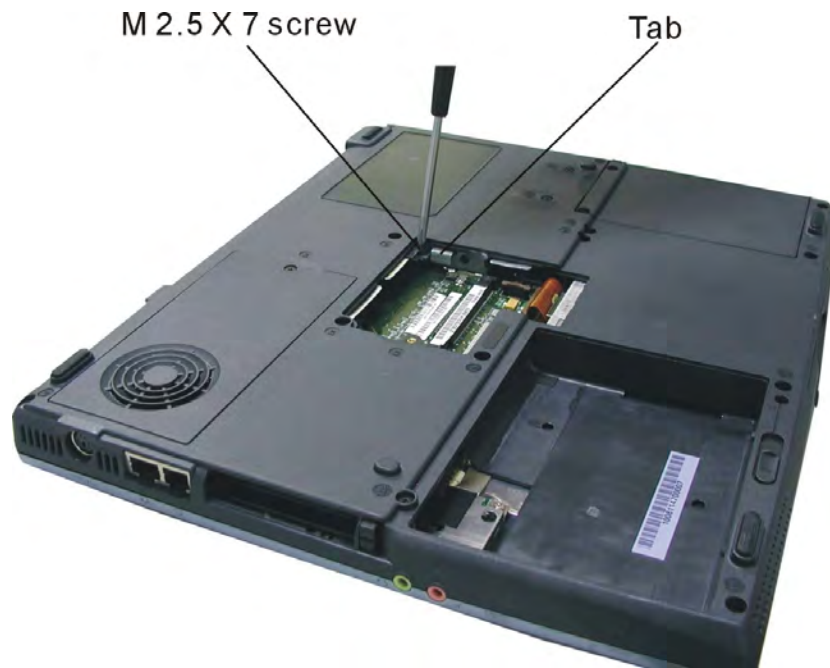

Figure 5-25: Removing one screw securing the CD-RW/DVD-ROM or CD-ROM/Combo Drive

3. Push on the tab to push out the drive. Grasp the front of the drive to pull it fully out.



Figure 5-26: Removing the CD-RW/DVD-ROM or CD-ROM/Combo Drive

4. Remove two M2.0x3 screws securing the drive bracket.

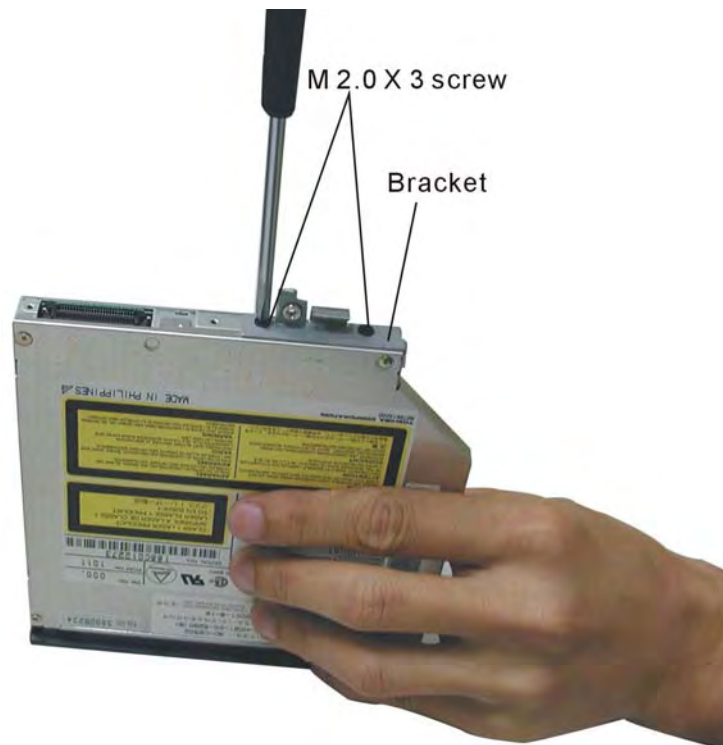

Figure 5-27: Removing the CD-RW/DVD-ROM or CD-ROM/Combo drive bracket

FDD

1. Remove one M2.5×5 screw securing the expansion memory compartment cover (see section 4.7). Lift off the cover.
2. Detach the FDD cable.
3. Remove one M2.5×5 screw next to the FDD cable securing the FDD.
4. Remove one M2.5×5 screw on the base securing the FDD.



Figure 5-28: Detaching the FDD

5. Push the FDD out until you can grasp the front. Then pull the entire unit out.
6. Detach the FDD brace. For the Panasonic FDD unit (pictured) remove three M2.5×3 screws from the sides and one M2×3 screw from the rear. For the Mitsui FDD unit, remove four M2×4 screws.
7. After detaching the FDD brace, detach the FDD cable.



Figure5-29: Removing the FDD brace and cable

HDD

1. Remove two M2.5×9 screws securing the HDD unit.

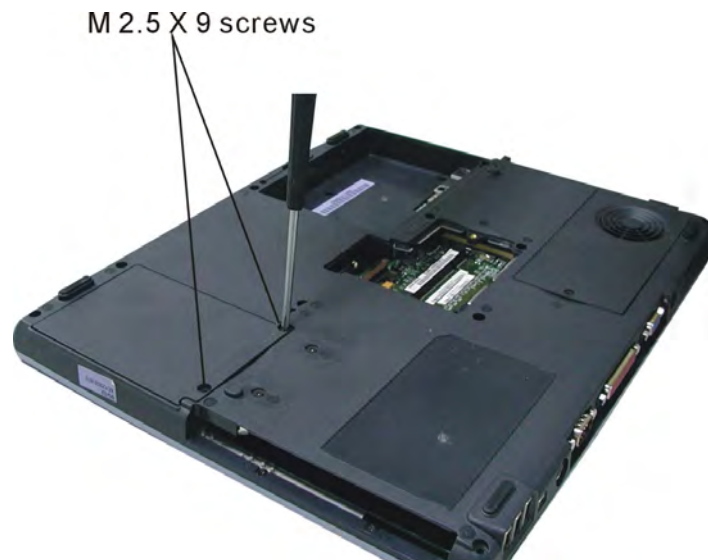

Figure 5-30: Removing two screws securing the HDD unit

2. Lift out the HDD unit.
3. Remove four M3×3 screws securing the HDD shielding.
4. Lift the HDD out of the shielding.
5. Pull off the HDD connector.

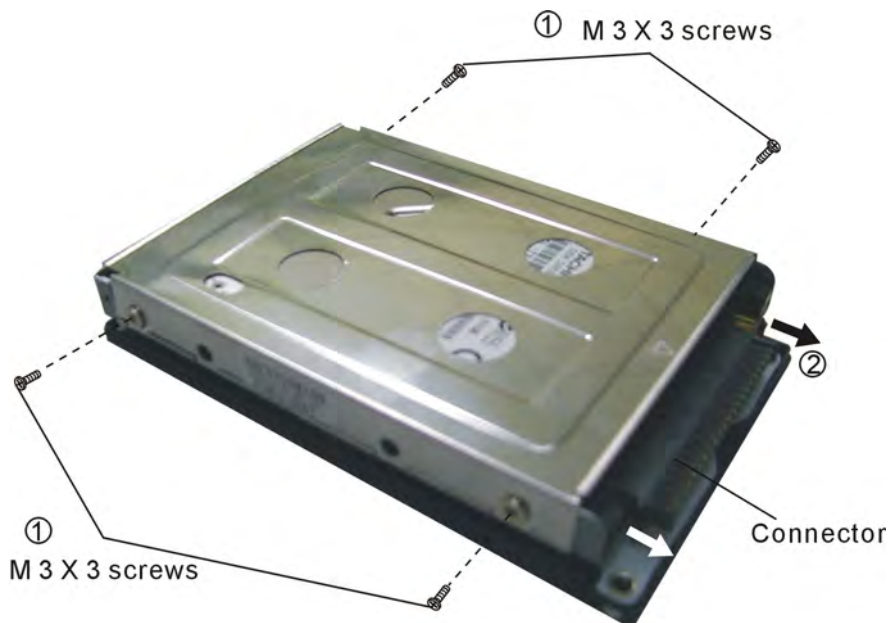

Figure 5-31: Removing the HDD shielding

Fan

1. Remove one M2.5×5 screw securing the CPU compartment cover.



Figure 5-32: Removing the CPU compartment cover

2. Remove two M2.5×7 screws securing the fan.
3. Lift the fan slightly so that you can detach the fan cable.
4. Remove the fan.

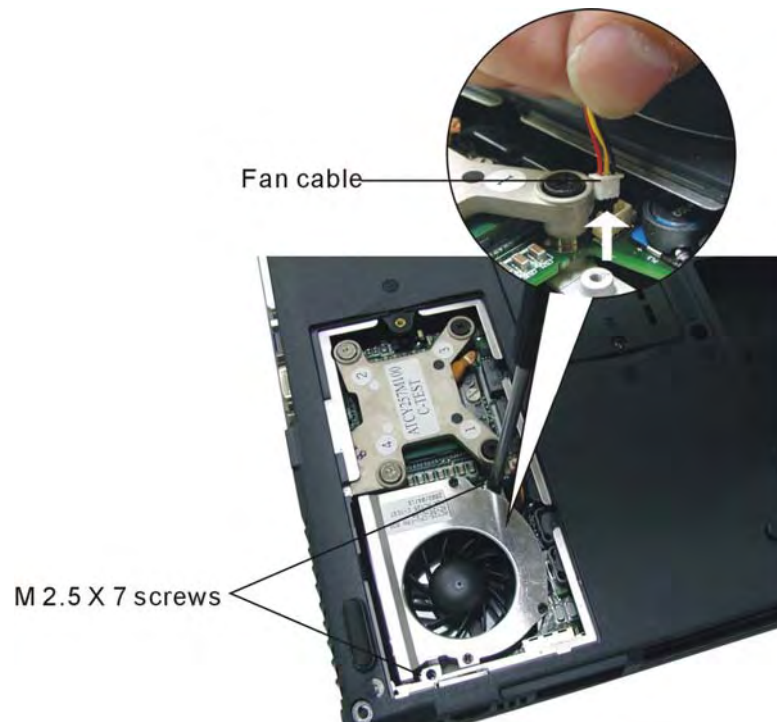

Figure 5-33: Detaching the fan

CPU

1. Remove one M2.5×5 screw securing the CPU compartment cover (see section 4.11).
2. Remove four screws securing the thermal unit

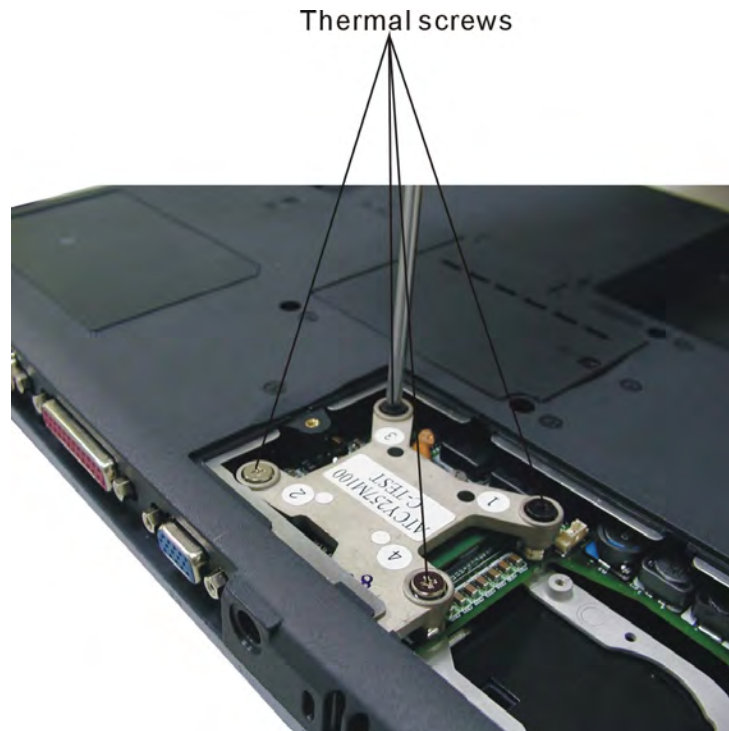

Figure 5-34: Removing four screws securing the thermal unit

3. Lift out the thermal unit.

4. Turn the cam on the CPU socket with a flat-blade screwdriver so that the notch on the cam is aligned with the "open" side of the CPU socket to unlock the CPU.
5. Gently lift out the CPU.

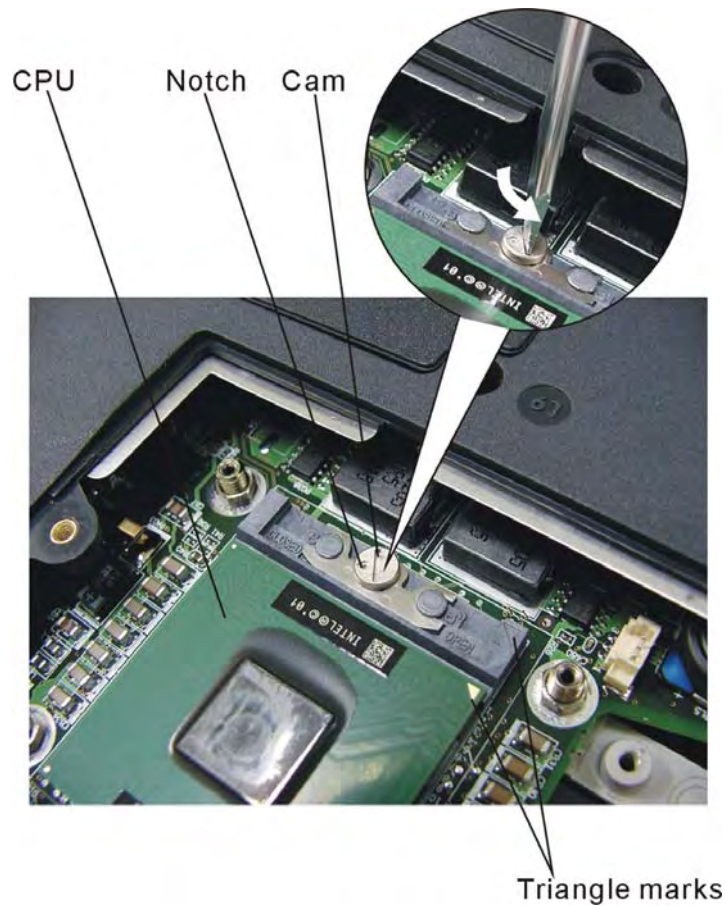

Figure 5-35: Removing the CPU

CAUTION: When replacing the CPU, make sure the triangle marks on the CPU and CPU socket are aligned before gently pressing the CPU into place.

CAUTION: You should change the thermal pad between the thermal unit and CPU before replacing the thermal unit.

CAUTION: When replacing the unit, be sure to fasten the screws in the order indicated on top of the unit).

Top Cover

1. Remove the following screws securing the top cover:

⇒ Two M2.5×12 screws

⇒ Two M2.5×5 screws

⇒ Two M2.5×3 screw

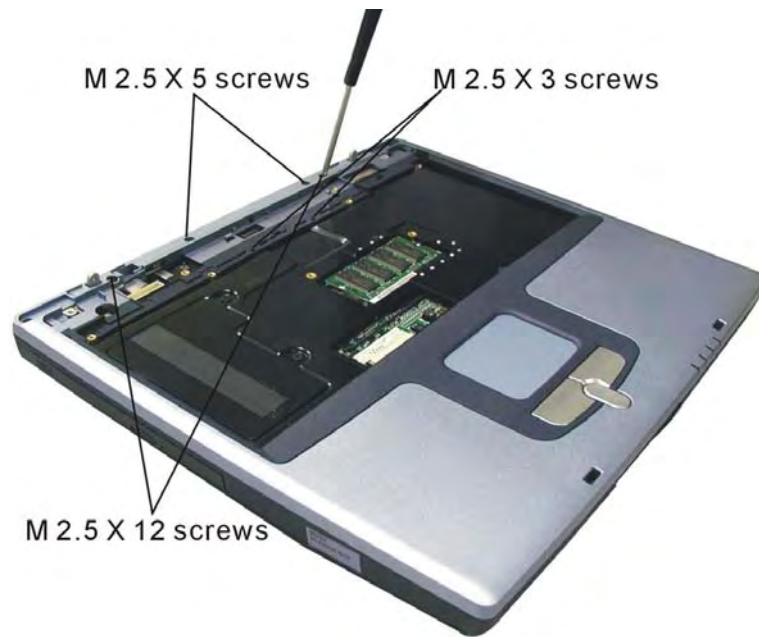

Figure 5-36: Removing five screws securing the top cover

2. Turn the computer over and remove the following screws securing the top cover:
 - ⇒ Eight M2.5×9 screws
 - ⇒ Two M2.5×18 screws
 - ⇒ Two M2.5×7 screws
 - ⇒ Two M2.5×5 screws

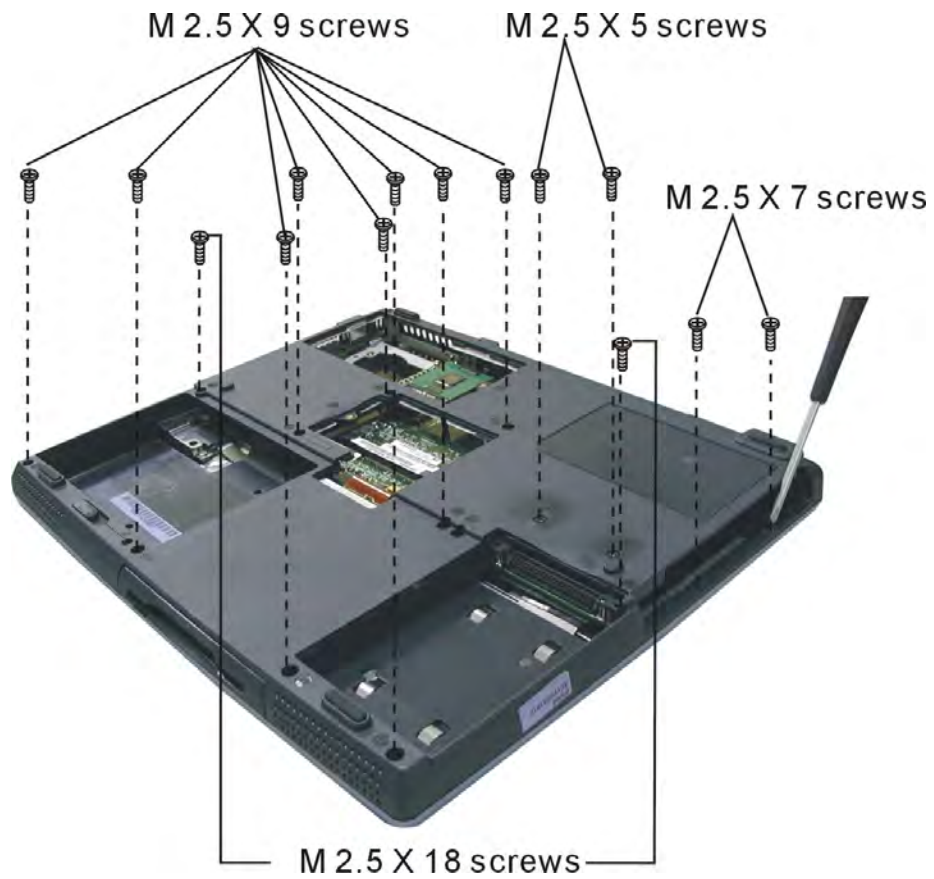

Figure 5-37: Removing 14 screws securing the top cover

3. Lift top cover off by pulling gently upwards from the back corners.

Touch Pad

1. Remove six M2.5×4 screws securing the mouse cover board.
2. Lift off the mouse cover board.
3. Detach the speaker cables from the audio board.

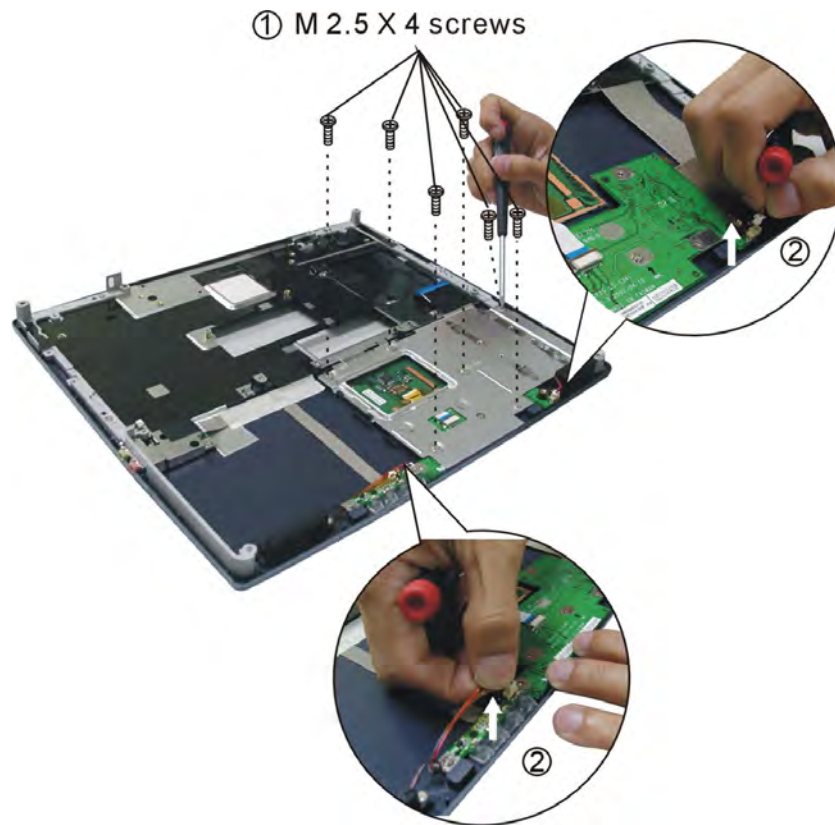

Figure 5-38: Removing the mouse cover board

4. Detach the Touch pad board FFC cable.
5. Remove two M2.5×4 screws securing the audio board.
6. Gently lift out and turn over the audio board.
7. Disconnect the microphone jack FFC.
8. Remove the audio board.

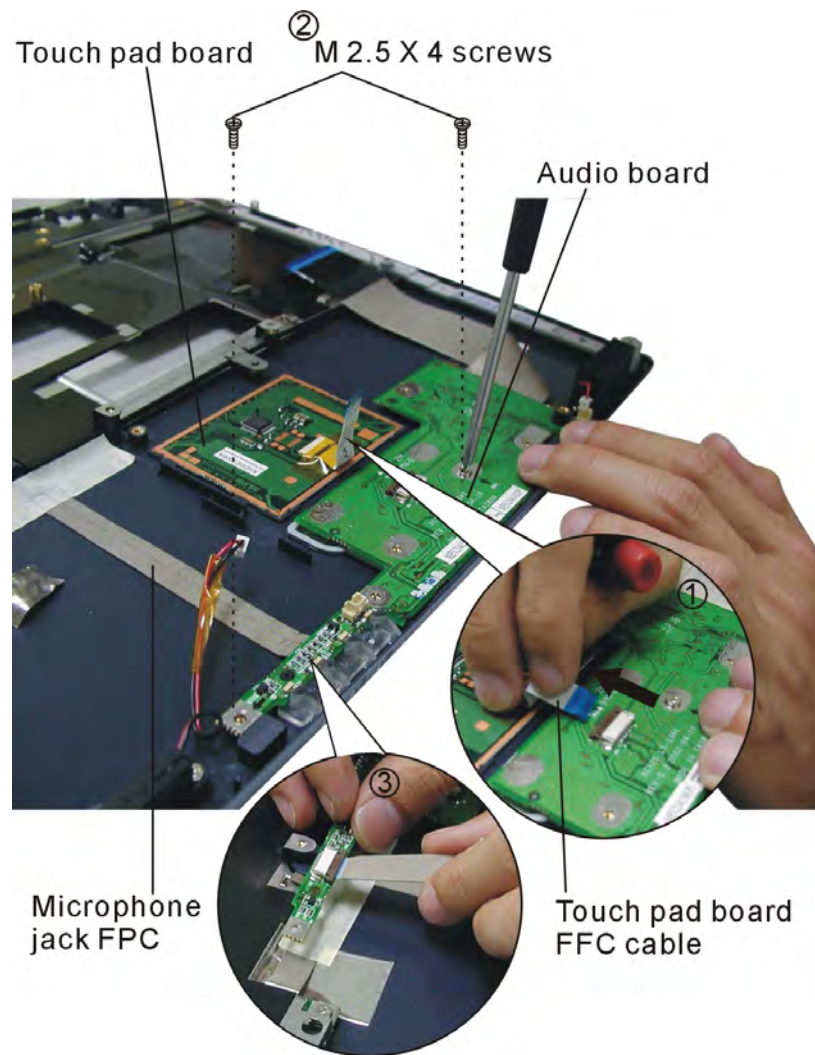

Figure 5-39: Removing the audio board

9. Lift out the touch pad board.

Speakers

1. Remove one M2.5×4 screw securing each of the speakers.
2. Detach both speaker cables from the audio board (you will already have detached the cables if you have removed the audio board).

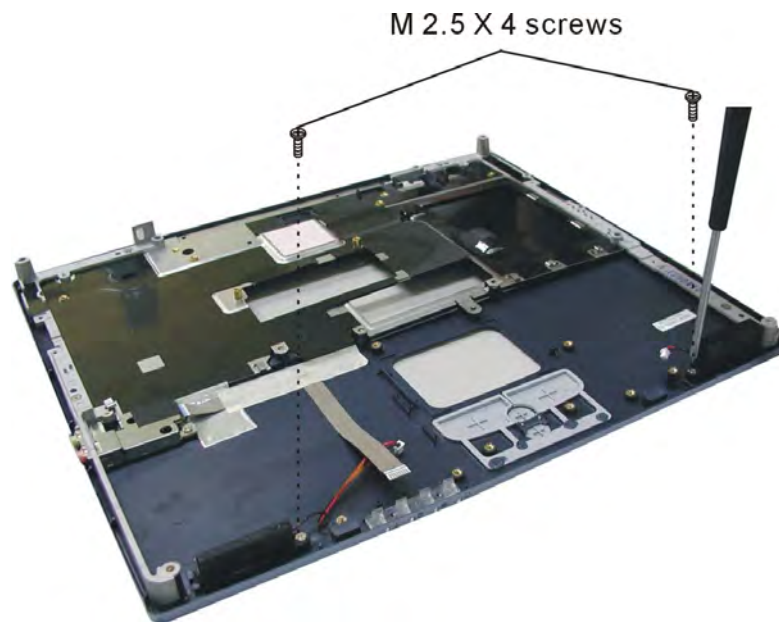

Figure 5-40: Removing the speakers

3. Lift out the speakers.

Microphone jack

1. Remove two M2.5×4 screws securing the microphone jack.
2. Peel off the tape securing the microphone jack FFC.
3. Remove the microphone jack.

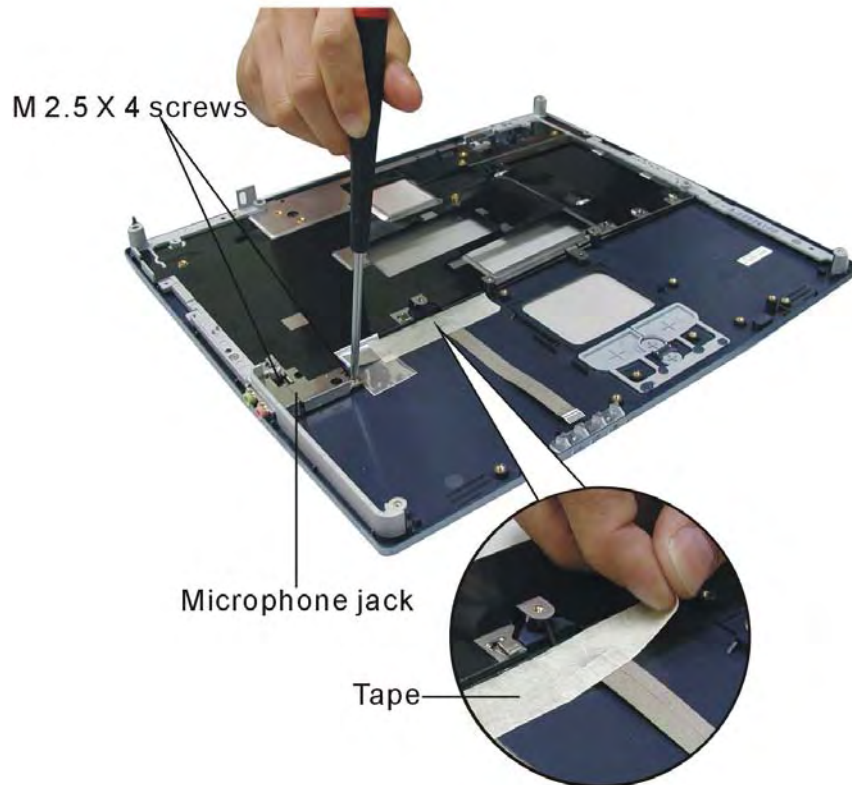

Figure 5-41: Removing the microphone jack

System Board

1. Remove three M2.5×5 screws securing the system board
2. Remove six helix screw nuts securing the rear ports.
3. Remove the system board by lifting from the center of the inside edge of the board.

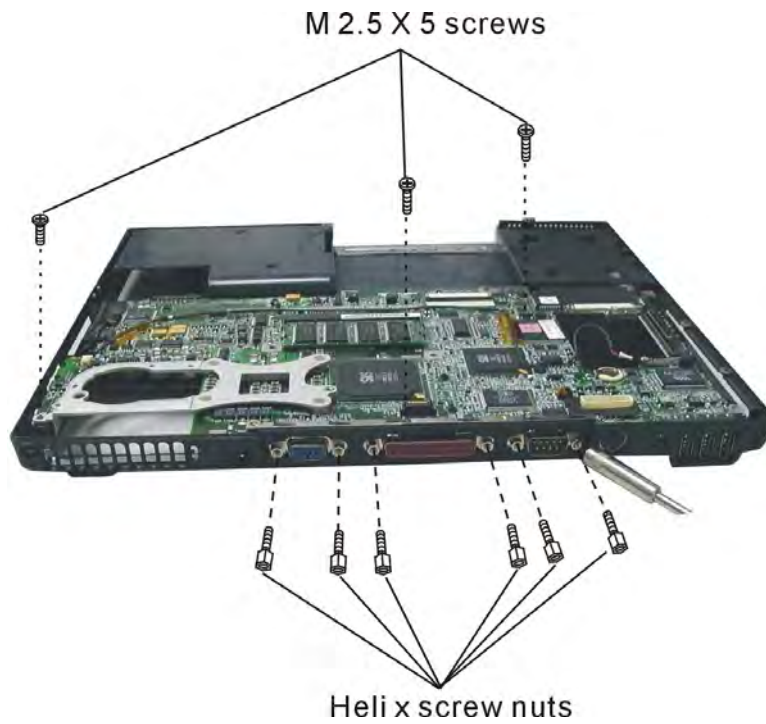

Figure 5-42: Removing the system board

Chapter 6: Testing and Troubleshooting

The purpose of this chapter is to provide a systematic method of isolating problems you may have with the ACY25 series Notebook Computer. We assume that you have a basic understanding of DOS-based computer systems as well as knowledge of standard trouble-shooting procedures. This manual is written under the assumption that the problems are indeed related with Notebook itself. The improper usage and application software problems are excluded in this chapter. The system BIOS Beep Code is an integrated unit to detect some errors in the system board. This beep code will give immediate identification of certain system board problems. If the troubleshooting procedure is followed step by step, it can efficiently isolate the problem and the problem can be solved easily.

PERFORM VISUAL INSPECTION

Check the following:

Power cords are properly connected and secured

Power supply is adequate for operation

There are no obvious shorts or opens

There are no obviously burned or heated components

All components appear normal

Troubleshooting Flowchart

Use the flowchart in Figure 6-1 as a guide for determining which troubleshooting procedures to execute. Before going through the flowchart steps, verify the following:

- Ask the user if a password is registered and, if it is, ask him or her to enter the password.
- Verify with the customer that Windows XP is installed on the hard disk. Operating systems that were not preinstalled by Compal can cause the computer to malfunction.
- Make sure all optional equipment is removed from the computer.
- Make sure the floppy disk drive is empty.

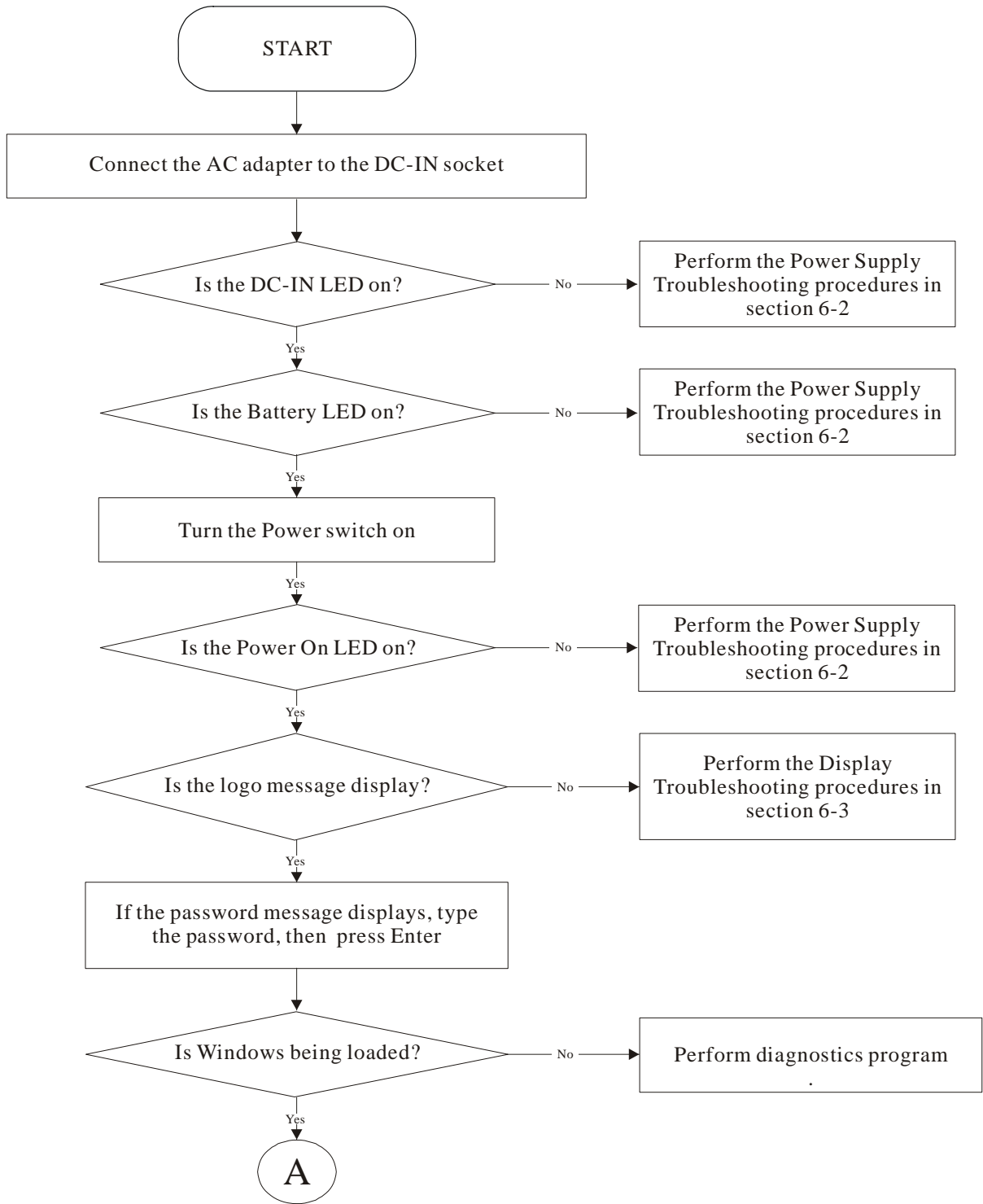

Figure 6-1 Troubleshooting flowchart (1/2)

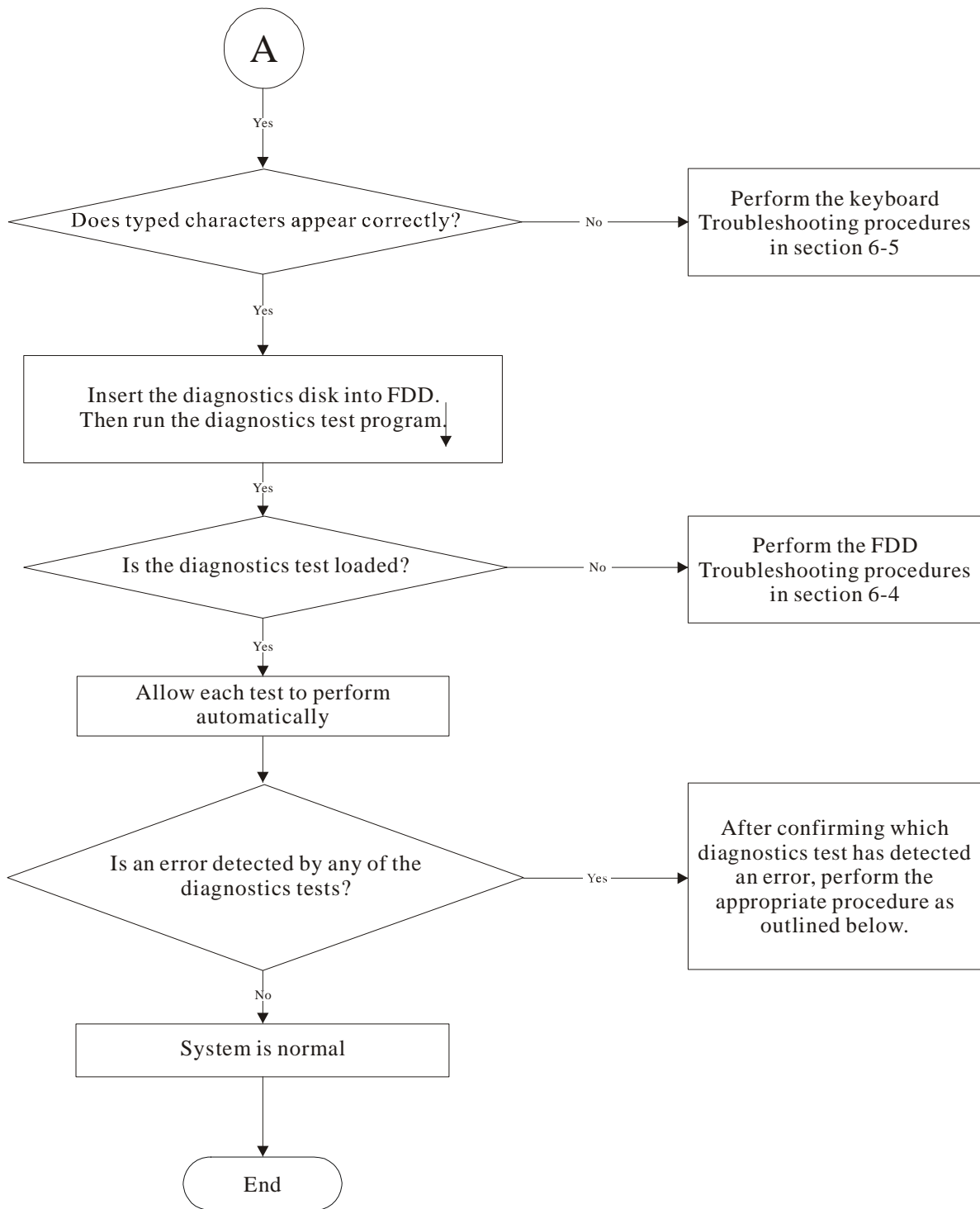

Figure 6-1 Troubleshooting flowchart (2/2)

If the diagnostics program cannot detect an error, the problem may be intermittent. The test program should be executed several times to isolate the problem. When a problem has been located, perform the appropriate troubleshooting procedures as follows:

1. If an error is detected by the main battery test, perform the Power Supply Troubleshooting procedures in Section 6-2.
2. If an error is detected by the display test, perform the Display Troubleshooting procedures in Section 6-3.
3. If an error is detected by the floppy disk test, perform the FDD Troubleshooting procedures in Section 6-4.
4. If an error is detected by the keyboard test, perform the Keyboard Troubleshooting procedures in Section 6-5.
5. If an error is detected by the printer (parallel) port test, perform the Printer Port Troubleshooting procedures in Section 6-8.
6. If an error is detected by the CD-ROM/DVD-ROM test, perform the DVD-ROM and CD-RW/DVD-ROM Troubleshooting Procedures in Section 6-11.
7. If an error is detected by the Modem test, perform the Modem Troubleshooting Procedures in Section 6-12 or the LAN Troubleshooting Procedures in Section 2.11.
8. If an error is detected by the Sound test, perform the Sound Troubleshooting Procedures in Section 2.12.

Other problems that are not covered by the diagnostics program may be discovered by a user.

1. If an error is detected when using an external USB device, perform the External USB Devices Troubleshooting procedures in Section 6-6.
2. If an error is detected when using the TV-out connection, perform the TV-Out Failure Troubleshooting procedures in Section 6-7.
3. If an error is detected when using the touch pad, perform the Touch Pad Troubleshooting procedures in Section 6-9.
4. If an error is detected when using the speakers, perform the Speaker Troubleshooting procedures in Section 6-10.
5. If an error is detected when using the CD/DVD drive, perform the CD-ROM/DVD Drive Troubleshooting procedures in Section 6-11.
6. If an error is detected when using the modem, perform the Modem Troubleshooting procedures in Section 6-12.
7. If an error is detected when using the PCMCIA unit, perform the PCMCIA Troubleshooting procedures in Section 6-13.

Power Supply Troubleshooting

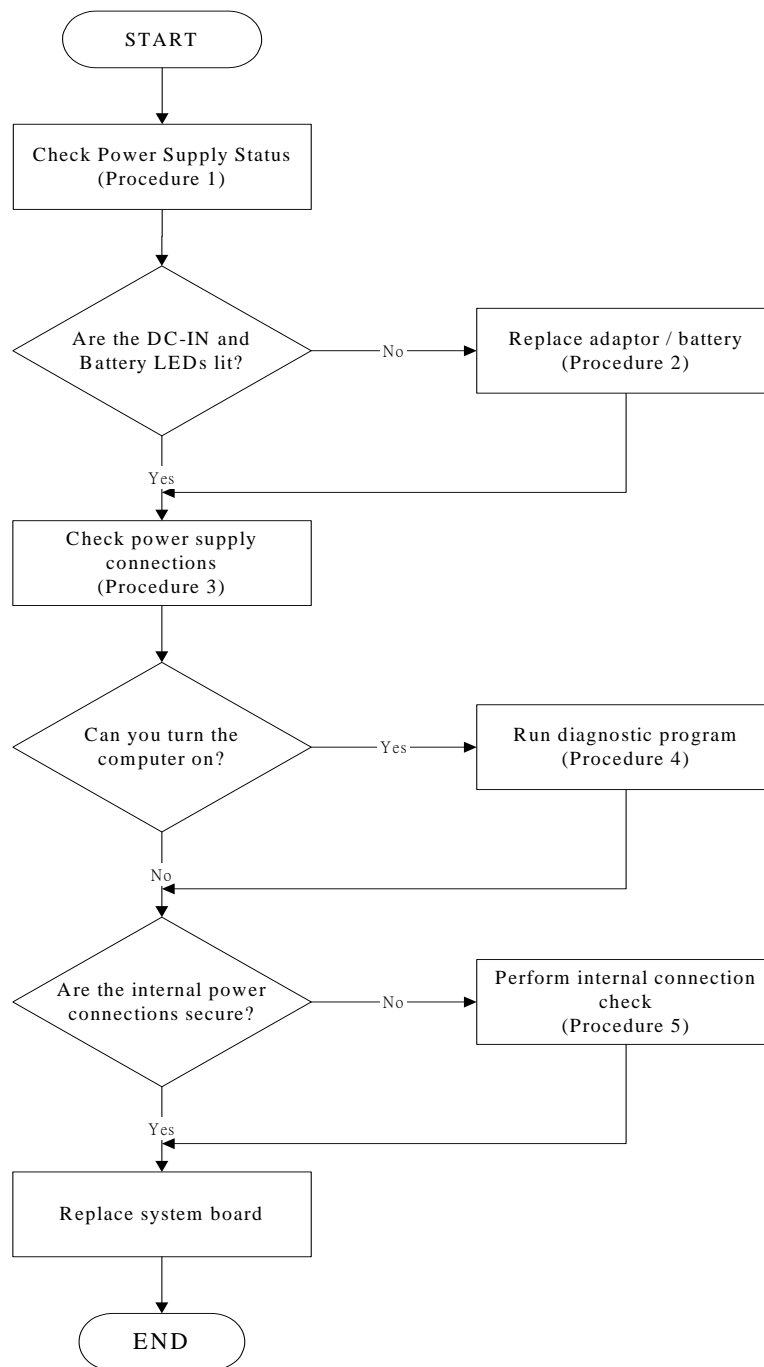

Figure 6-2 Power Supply Troubleshooting Process

The power supply controls many functions and components. To determine if the power supply is functioning properly, start with Procedure 1 and continue with the other Procedures as instructed. The flowchart in Figure 6-2 gives a summary of the process. The procedures described in this section are:

- Procedure 1: Power status check
- Procedure 2: Adaptor / battery replacement
- Procedure 3: Power supply connection check
- Procedure 4: Diagnostic check
- Procedure 5: Internal connection check

Procedure 1 Power Status Check

The following LEDs indicate the power supply status:

 Battery LED

 DC-IN LED

The power supply controller displays the power supply status through the Battery and the DC-IN LEDs as listed in the tables below.

Table 2-1 Battery LED

Battery State	LED colors	Definition
Charging	Amber, solid on	Battery charging with AC .
	Green, solid on	Battery fully charged by AC
	Green color off	Battery abnormal: stop charging with AC (Bad cell/ Overheated)
Discharging	Amber, blinking LED on for 1 second every 4 seconds	Battery within low state: 12 minutes remaining
	Amber, blinking (LED on 1 second every 2 seconds)	Battery within critical low state: 3 minutes remaining. The system is protected and cannot be re-powered on without the AC power connected.
	Amber color off	Battery not in low or critical low state; in discharging state

Table 2-2 DC-IN LED

DC-IN LED	Power supply status
Solid on	AC power exists (LED is solid green).
Off	No AC power exists.

To check the power supply status, install a battery pack and connect an AC adaptor to the DC-IN port on the computer and to a power supply.

If the DC-IN LED or Battery LED are not lit, go to Procedure 2

Procedure 2 Adaptor / battery replacement

A faulty adaptor may not supply power or may not charge the battery. Perform Check 1.

Check 1 Connect a new AC adaptor. If the problem is not resolved, go to Check 2.

Check 2 Insert a new battery. If the problem is still not resolved, go to Procedure 3.

Procedure 3 Power supply connection check

The power supply wiring diagram is shown below:

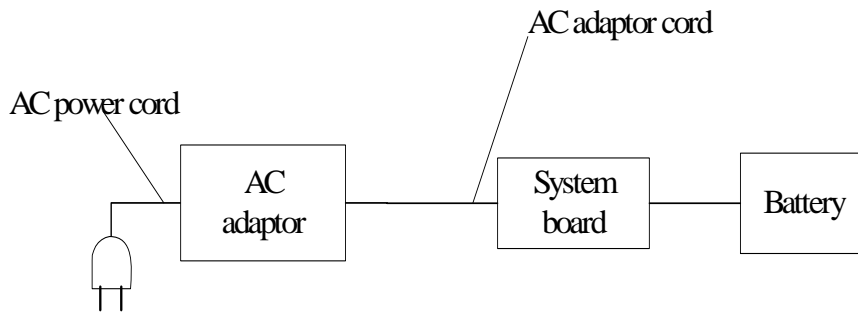

Any of the connectors may be disconnected. Perform Check 1.

Check 1 Disconnect the AC power cord from wall outlet. Check the power cable for breaks. If the power cord is damaged, connect a new AC power cord. If there is no damage, go to Check 2.

Check 2 Make sure the AC adaptor cord and AC power cord are firmly plugged into the DC-IN socket, AC adaptor inlet and wall outlet. If these cables are connected correctly, go to Check 3.

Check 3 Make sure that the DC-IN input port socket is firmly secured to the system board of the computer.

- If the DC-IN input socket is loose, go to Procedure 5.
- If it is not loose, go to Check 4.

Check 4 Use a multimeter to make sure that the AC adaptor output voltage is close to 19 V. If the output is several percent lower than 19 V, go to Check 5. If the output is close to 19 V, go to Check 6.

Check 5 Connect a new AC adaptor or AC power cord.

- If the DC-IN LED does not light, go to Procedure 4.
- If the battery LED does not light, go to Check 6.

Check 6 Make sure the battery pack is installed in the computer correctly. If the battery is properly installed and the battery LED still does not light, go to Procedure 4.

Procedure 4 Diagnostic check

The power supply may not charge the battery pack. Perform the following procedures:

1. Reinstall the battery pack.
2. Attach the AC adaptor and turn on the power. If you cannot turn on the power, go to Procedure 5.
3. Run the Diagnostic test following the procedures described Tests and Diagnostics. If no problem is detected, the battery is functioning normally.

Procedure 5 Replacement check

The system board may be disconnected or damaged. Disassemble the computer following the steps described *Replacement Procedures*. Check the connection between the AC adaptor and the system board. After checking the connection, perform Check 1:

- Check 1 Use a multimeter to make sure that the fuses on the system board are not blown. If a fuse is not blown, go to Check 2. If a fuse is blown, go to Check 3.
- Check 2 Make sure that the battery cable is firmly connected to the system board. If it is connected firmly, go to Check 3.
- Check 3 The system board may be damaged. Replace it with a new one following the instructions in Chapter 4.

Display Troubleshooting

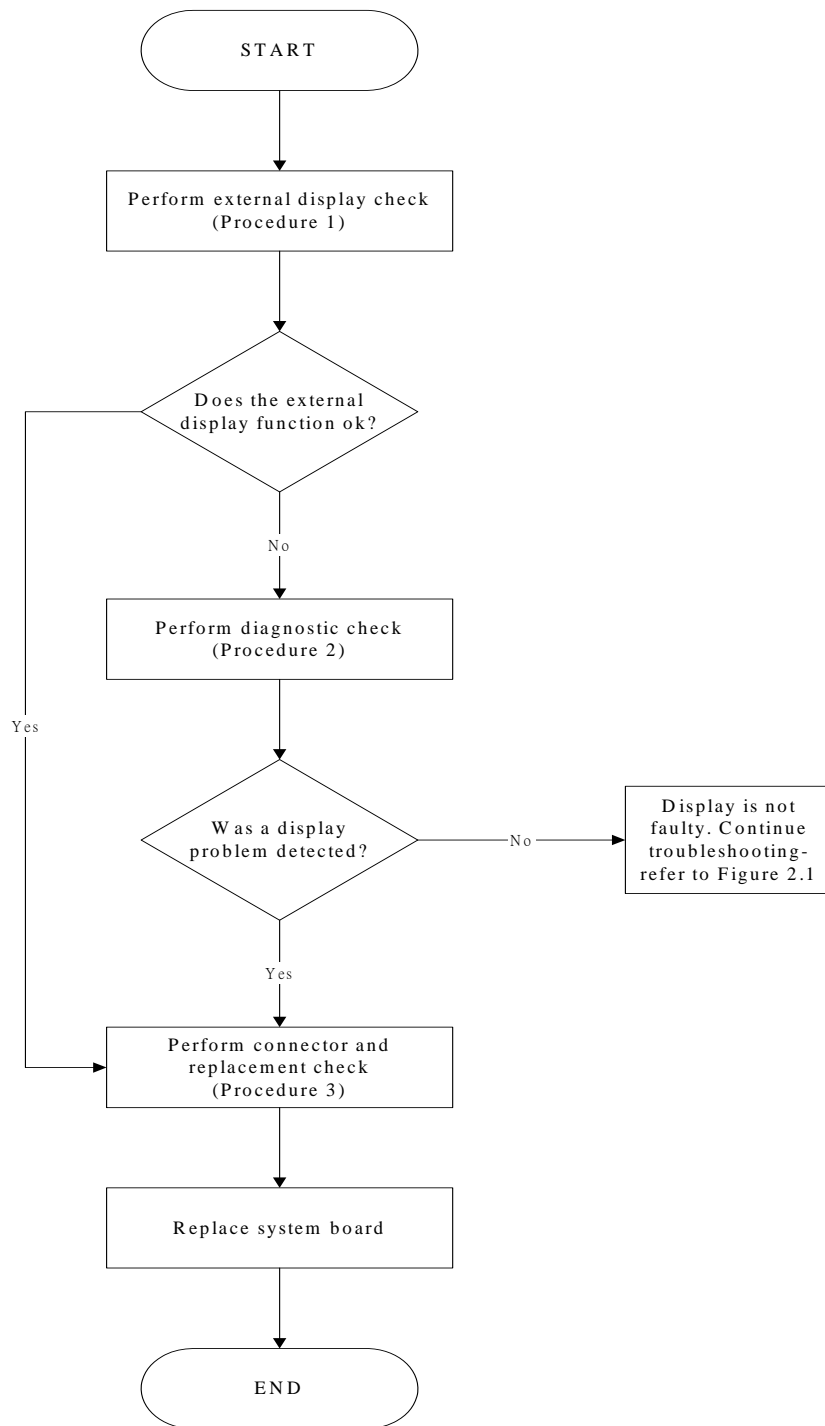

Figure 6-3 Display troubleshooting process

This section describes how to determine if the computer's display is functioning properly. The process is outlined in Figure 6-3. Start with Procedure 1 and continue with the other procedures as instructed.

Procedure 1: External display check

Procedure 2: Diagnostic check

Procedure 3: Connector and replacement check

Procedure 1 External display check

Connect an external display to the computer's external monitor port, then boot the computer. The computer automatically detects the external display. Press Fn+F5 to switch to the external display.

If the external display works correctly, the internal LCD may be damaged. Go to Procedure 3.

If the external monitor appears to have the same problem as the internal monitor, the system board may be damaged. Go to Procedure 2.

Procedure 2 Diagnostic check

The Display Test program is stored on the computer's Diagnostics disk. This program checks the display controller on the system board. Insert the Diagnostics disk in the computer's floppy disk drive, turn on the computer and run the test. Refer to Chapter 3, *Tests and Diagnostics* for details.

If an error is detected, go to Procedure 3. If an error is not detected, the display is functioning properly.

Procedure 3 Connector and replacement check

The FL inverter board, LCD module, and system board are connected to the display circuits. Any of these components may be damaged. *Replacement Procedures*, for instructions on how to disassemble the computer and then perform the following checks:

- Check 1 Make sure the DDRRAM module is seated properly. Test display again. If the problem still exists, replace the DDRRAM module. If the problem still exists, perform check 2.
- Check 2 Replace the FL inverter board with a new one and test display again. If the problem still exists, perform Check 3.
- Check 3 Replace the LCD module with a new one and test display again. If the problem still exists, perform Check 4.
- Check 4 Replace the LCD/FL cable with a new one and test display again. If the problem still exists, perform Check 5.
- Check 5 Replace the CPU with another of the same specifications. If the problem still exists, perform Check 6.
- Check 6 The system board may be damaged. Replace it with a new one.

FDD Troubleshooting

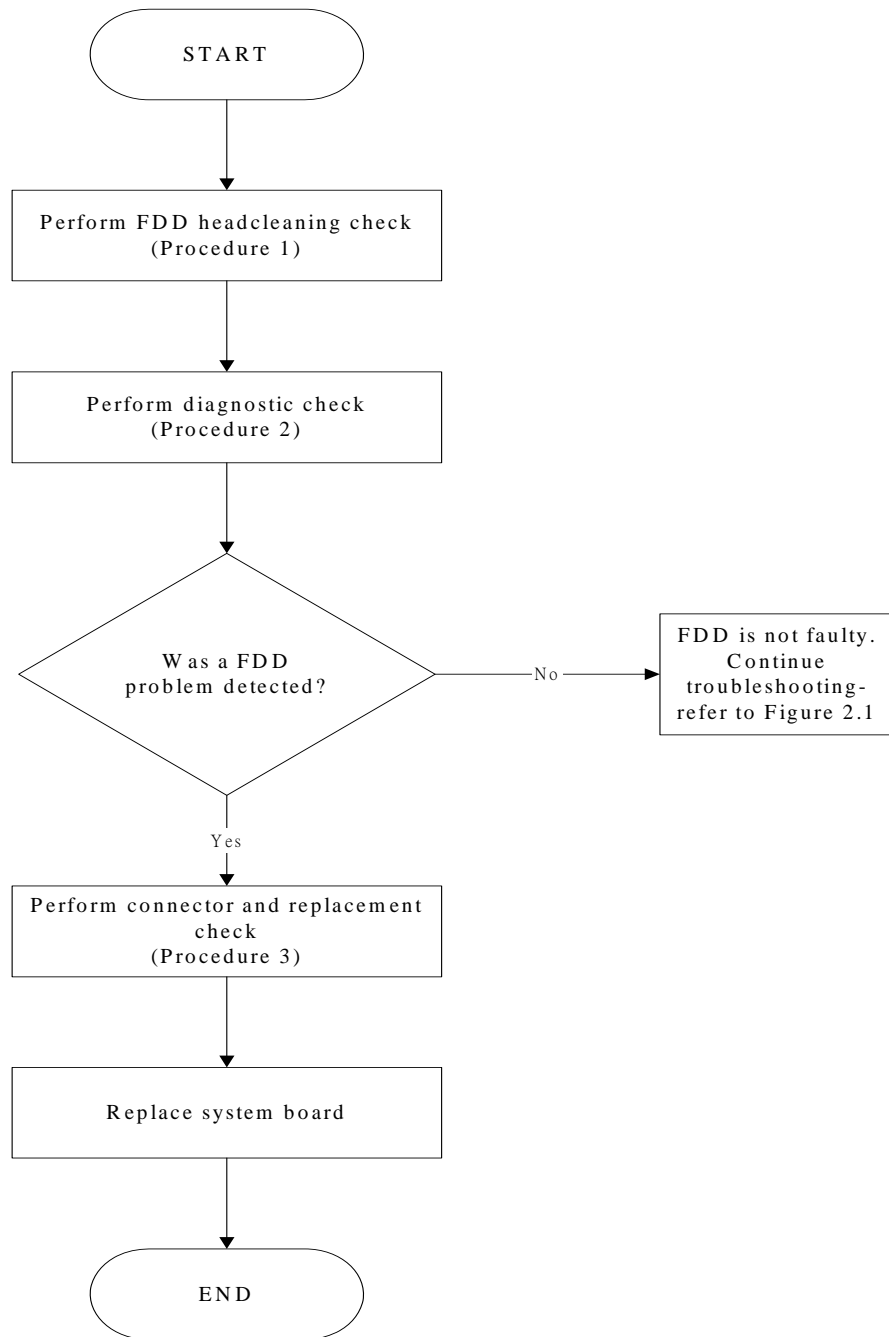

Figure 6-4 FDD troubleshooting process

This section describes how to determine if the FDD is functioning properly. Perform the steps below starting with Procedure 1 and continuing as required. Figure 6-4 gives an outline of the process.

Procedure 1: FDD head cleaning check

Procedure 2: Diagnostic check

Procedure 3: Connector check and replacement check

Procedure 1 FDD head cleaning check

The FDD heads can become dirty over time, affecting their performance. Use an FDD cleaning kit to clean the heads. If the FDD still does not function properly after cleaning, go to Procedure 2.

Procedure 2 Diagnostic check

Insert the Diagnostics Disk in the FDD, turn on the computer and run the test.

If no FDD problem is detected by the diagnostic test, the FDD is functioning normally. If an error occurs, go to Procedure 3.

Procedure 3 Connector check and replacement check

The 3.5-inch FDD is connected to the system board. For instructions on how to disassemble the computer and then perform the following checks:

- Check 1 Make sure the FDD flexible cable is firmly connected to the FDD and system board. If any of the connections are loose, reconnect firmly and repeat Procedure 2. If any of the connections is damaged, or there is still an error, go to Check 2.
- Check 2 The FDD unit or FDD flexible cable may be defective or damaged. If the FDD is still not functioning properly, perform Check 3.
- Check 3 Replace the system board.

Keyboard Troubleshooting

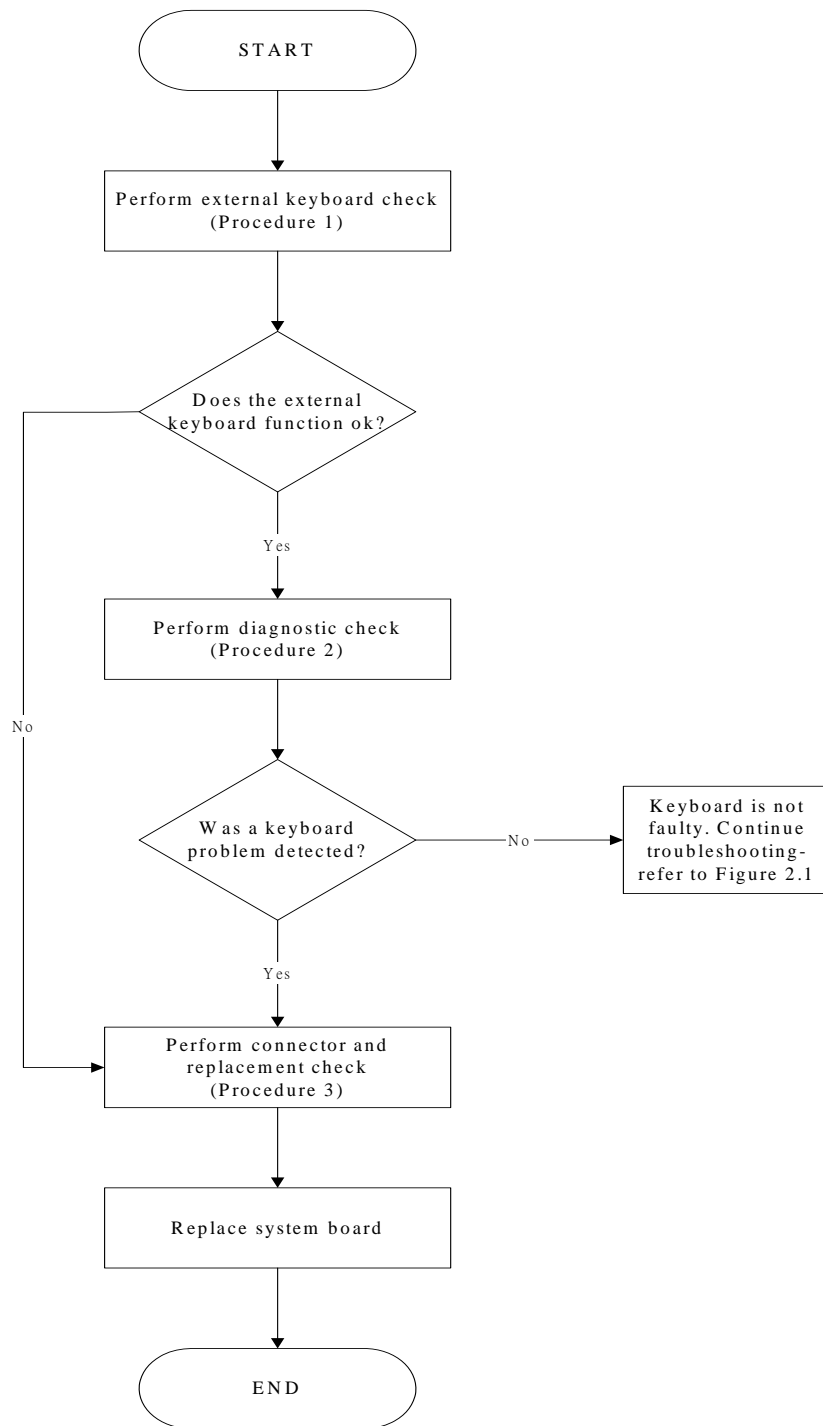

Figure 6-5 Keyboard troubleshooting process

To determine if the computer's keyboard is functioning properly, perform the following procedures. Figure 6-5 outlines the process. Start with Procedure 1 and continue with the other procedures as instructed.

Procedure 1: External keyboard check

Procedure 2: Diagnostic check

Procedure 3: Connector and replacement check

Procedure 1 External keyboard check

Connect a USB keyboard to one of the computer's keyboard/mouse ports, then boot the computer. The computer automatically detects the external keyboard.

If the external keyboard works correctly, the internal keyboard or its connections may be faulty. Go to Procedure 2.

If the external keyboard appears to have the same problem as the internal keyboard, the system board may be damaged.

Procedure 2 Diagnostic test

Run the Diagnostic Program, which will automatically execute the Keyboard Test. Refer to Chapter 3, *Tests and Diagnostics* for more information on how to run the program.

If an error is located, go to Procedure 3. If an error does not occur, the keyboard is functioning properly.

Procedure 3 Connector and replacement check

The keyboard and/or system board may be disconnected or damaged. *Replacement Procedures* and perform the following checks.

Check 1 Make sure the keyboard cable is firmly connected to the system board.

If the connection is loose, reconnect firmly and repeat Procedure 2. If there is still an error, go to Check 2.

Check 2 The keyboard may be damaged.

If the problem still exists, perform Check 3.

Check 3 The system board may be damaged. R

External USB Devices Troubleshooting

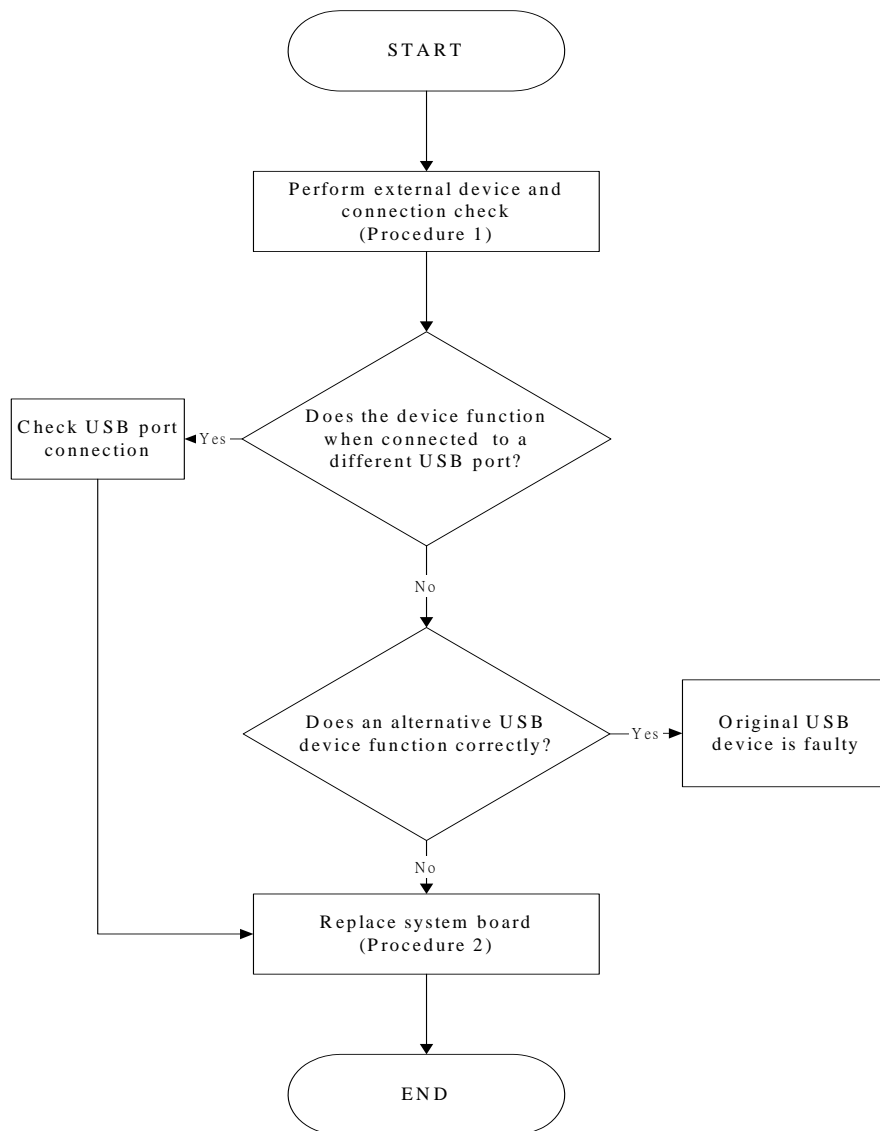

Figure 6-6 External USB device troubleshooting process

To determine if the computer's external USB devices are functioning properly, perform the following procedures. Figure 6-6 outlines the process. Start with Procedure 1 and continue as instructed.

Procedure 1: External device and connection check

Procedure 2: Replace system board

Procedure 1 External device and connection check

The USB device may be damaged or the connection may be faulty. Perform Check 1.

Check 1 Make sure USB device cable is firmly plugged into one of the USB sockets. If the cable is connected correctly, go to Check 2.

Check 2 Plug the USB device into another USB socket (there are three in all). If the USB device still does not work, go to Check 4.

If the device functions correctly when connected to another USB port, go to Check 3

Check 3 Make sure that the USB socket is firmly secured to the system board of the computer. If the malfunction remains, the system board may be damaged. Go to Procedure 2.

Check 4 Connect an alternative USB device to one of the computer's USB ports, and then boot the computer. The computer automatically detects the external device.

If the alternative USB device works correctly, the original device may be damaged and should be replaced.

If the alternative USB device appears to have the same problem as the original device, the system board may be damaged. Go to Procedure 2.

Procedure 2 Replace system board

If the error persists, the system board may be damaged.

TV-Out Failure Troubleshooting

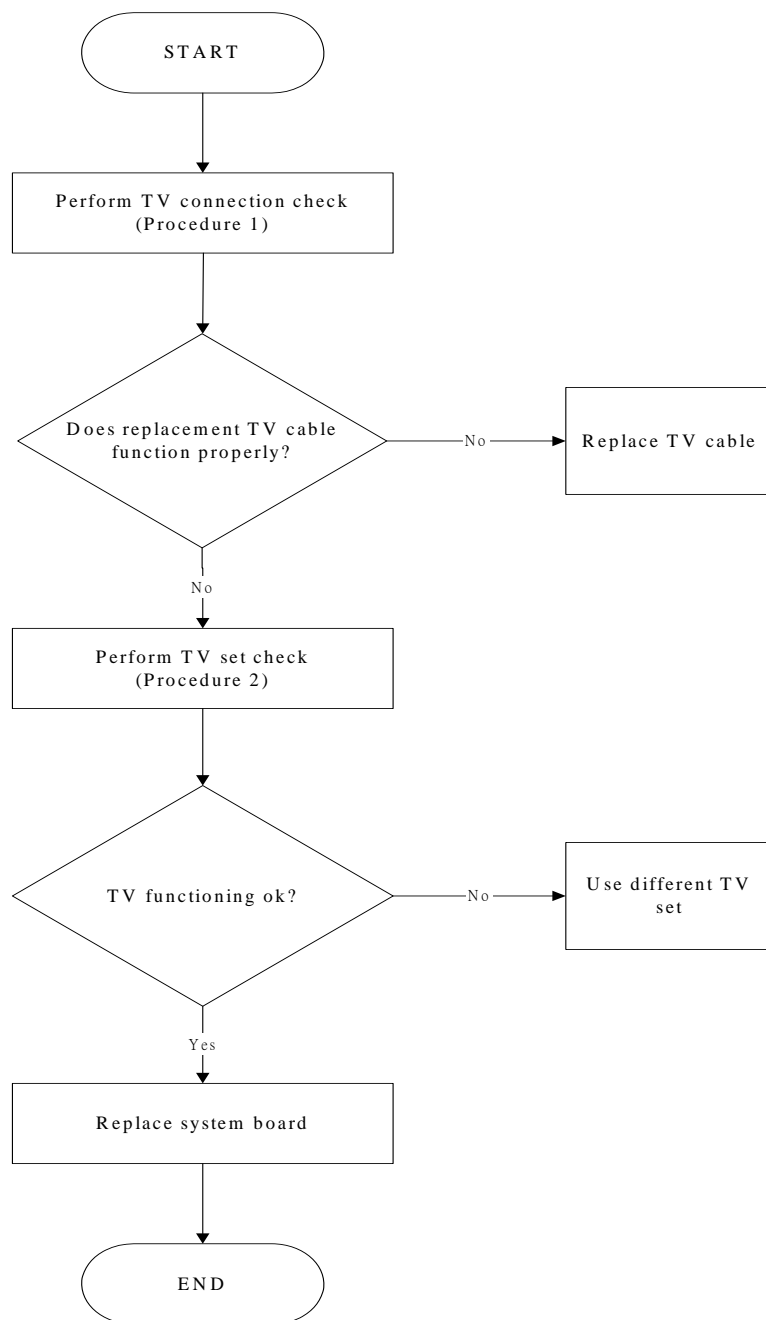

Figure 6-7 TV-out troubleshooting process

To determine if the computer's TV-out port is functioning properly, perform the following procedures. Figure 6-7 outlines the process. Start with Procedure 1 and continue as instructed.

Procedure 1: TV connection check

Procedure 2: TV set check

Procedure 1 TV connection check

The TV cable may be damaged or the connections may be loose. Perform Check 1:

Check 1 Make sure TV cable is firmly plugged into both the TV set and the TV-out port of the computer. If the cable is connected correctly, go to Check 2.

Check 2 Make sure the TV-out port is firmly secured to the system board of the computer. If the malfunction remains, go to Check 3.

Check 3 The TV cable may be damaged. Replace with a good cable. If the malfunction remains, go to Procedure 2

Procedure 2 TV set check

The TV set may be faulty. Perform Check 1:

Check 1 Try using the set for television reception. If it does not work, the set may be damaged. If the set does work, perform Check 2.

Check 2 Try connecting a different television to the computer. If the replacement television works, the original set may be damaged. If the replacement set does not work the system board may be damaged.

Printer Port Troubleshooting

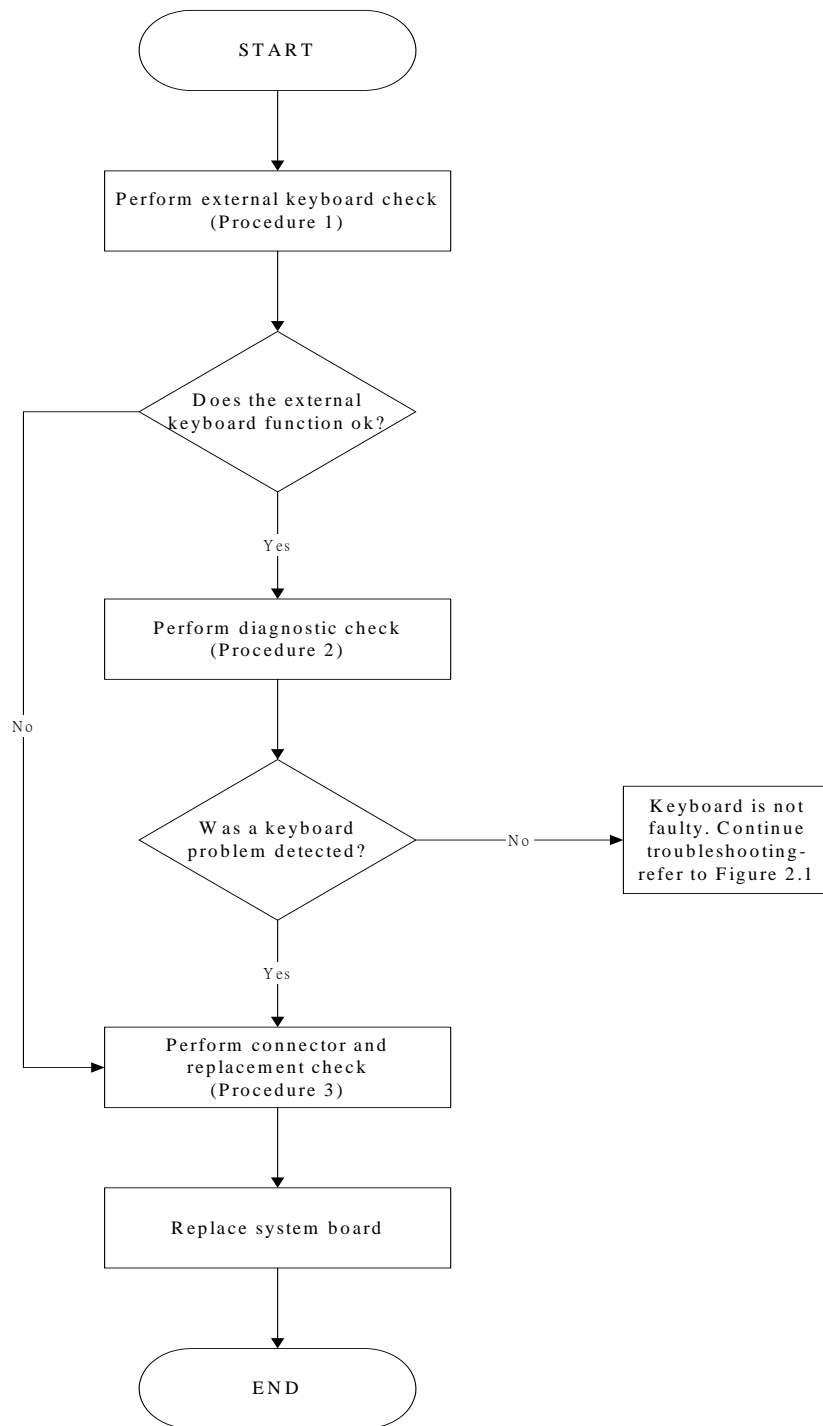

Figure 6-8 Printer port troubleshooting process

To determine if the computer's printer (parallel) port is functioning properly, perform the following procedures. Figure 6-8 outlines the process. Start with Procedure 1 and continue as instructed.

Procedure 1: Diagnostic test

Procedure 2: Printer and connection test

Procedure 3: Replace system board

Procedure 1 Diagnostic test

Attach the printer port loopback connector firmly to the printer port and run the Diagnostic Program. If the printer port test passes, there may be a problem with the printer. Go to Procedure 2. If the printer port test fails, go to Procedure 3.

Procedure 2 Printer and connection test

The printer may be faulty or not connected properly. Perform Check 1.

Check 1 Make sure printer cable is firmly plugged into both the printer and the printer port of the computer. If the cable is connected correctly, go to Check 2.

Check 2 Make sure the printer port is firmly secured to the system board of the computer. If the malfunction remains, go to Check 3.

Check 3 The printer cable may be damaged. Replace with a good cable. If the malfunction remains, go to Check 4.

Check 4 The printer may be faulty. Replace it with a good printer or connect it to a different computer.

If the replacement printer works or the original printer does not work on a different computer, the printer should be replaced.

If the replacement printer does not work either, or the original printer functions normally on a different computer, go to Procedure 3.

Procedure 3 Replace system board

The system board may be damaged.

Touch Pad Troubleshooting

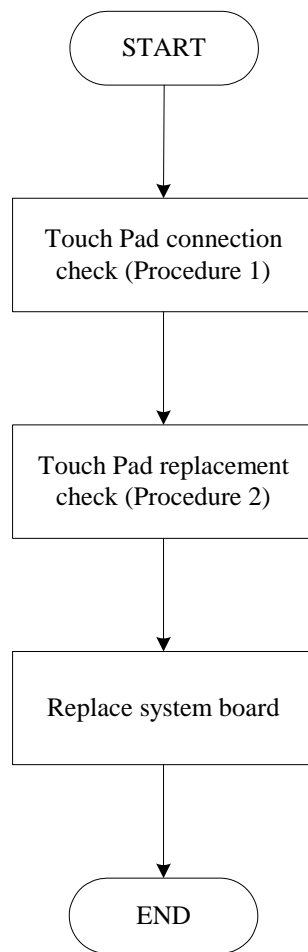

Figure 6-9 Touch Pad troubleshooting process

To determine if the computer's built-in Touch Pad is functioning properly, perform the following procedures. Figure 6-9 outlines the process. Start with Procedure 1 and continue as instructed.

Procedure 1: Touch Pad connection check

Procedure 2: Touch Pad replacement check

Procedure 1 Touch Pad connection check

The Touch Pad is connected by the Touch Pad FPC to the system board. Make sure the Touch Pad FPC cable is firmly connected to the Touch Pad and system board. *Replacement Procedures*, for instructions on how to disassemble the computer and then perform the following checks.

If any of the connections are loose, reconnect firmly. If any of the connections is damaged, or there is still an error, go to Procedure 2.

Procedure 2 Touch Pad replacement check

The Touch Pad unit or FPC may be defective or damaged.

Speaker Troubleshooting

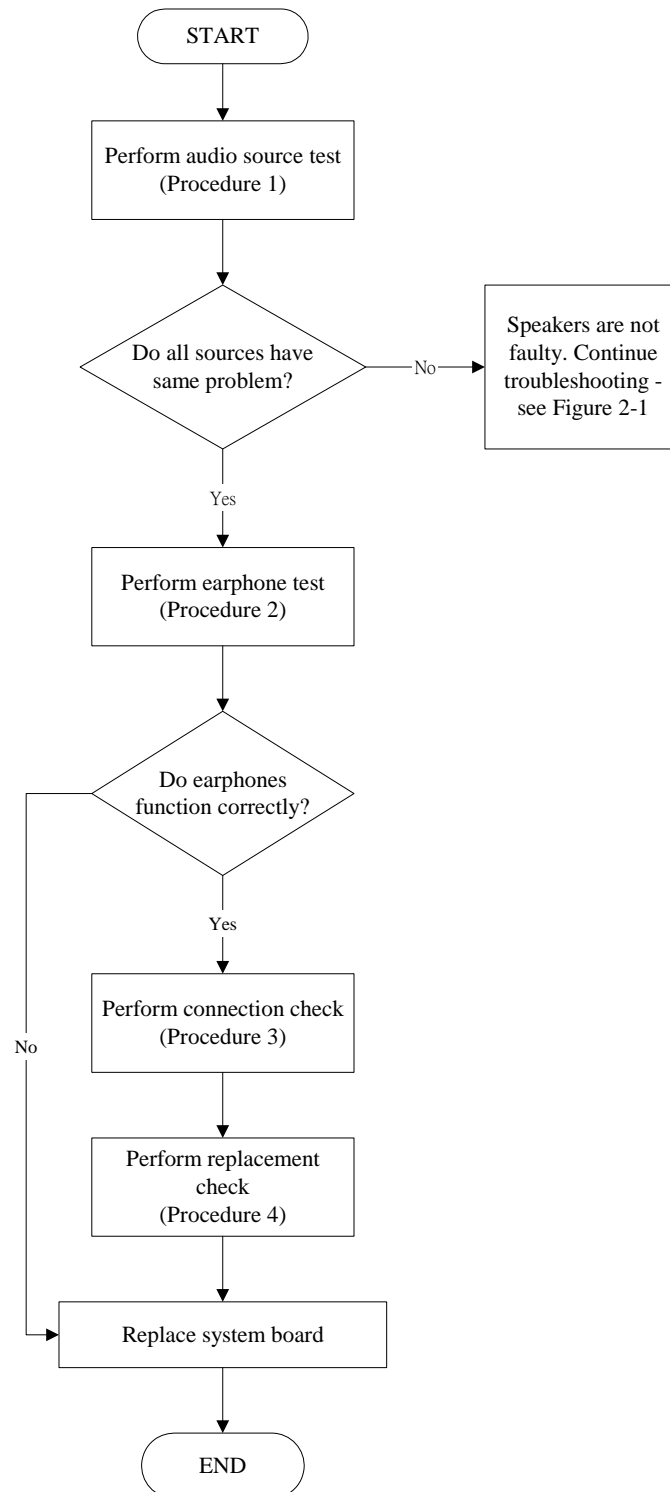

Figure 6-10 Speaker troubleshooting process

To determine if the computer's built-in speakers are functioning properly, perform the following procedures. Figure 6-10 outlines the process. First adjust the speaker volume to an appropriate level. Start with Procedure 1 and continue as instructed.

Procedure 1: Audio source test

Procedure 2: Earphone test

Procedure 3: Connection check

Procedure 4: Replacement check

Procedure 1 Audio source test

Try different audio sources (e.g. an audio CD and digital music file) to determine whether the fault is in the speaker system or not. If not all sources have sound problems, the problem is in the source devices. If all have the same problem, continue with Procedure 2.

Procedure 2 Earphone test

Connect a set of earphones or external speakers. If these function correctly, go to Procedure 3. If they do not function correctly, the system board may be defective or damaged. Replace it with a new one.

Procedure 3 Connection check

Disassemble the computer following the steps described *Replacement Procedures* and make sure the speaker cable is firmly connected to the system board. If the stereo speakers are still not functioning properly, go to Procedure 4.

Procedure 4 Replacement Check

If the stereo speakers don't sound properly, the stereo speakers may be defective or damaged. Replace them with new ones. If the stereo speakers still do not work properly.

DVD-ROM and CD-RW/DVD-ROM Troubleshooting

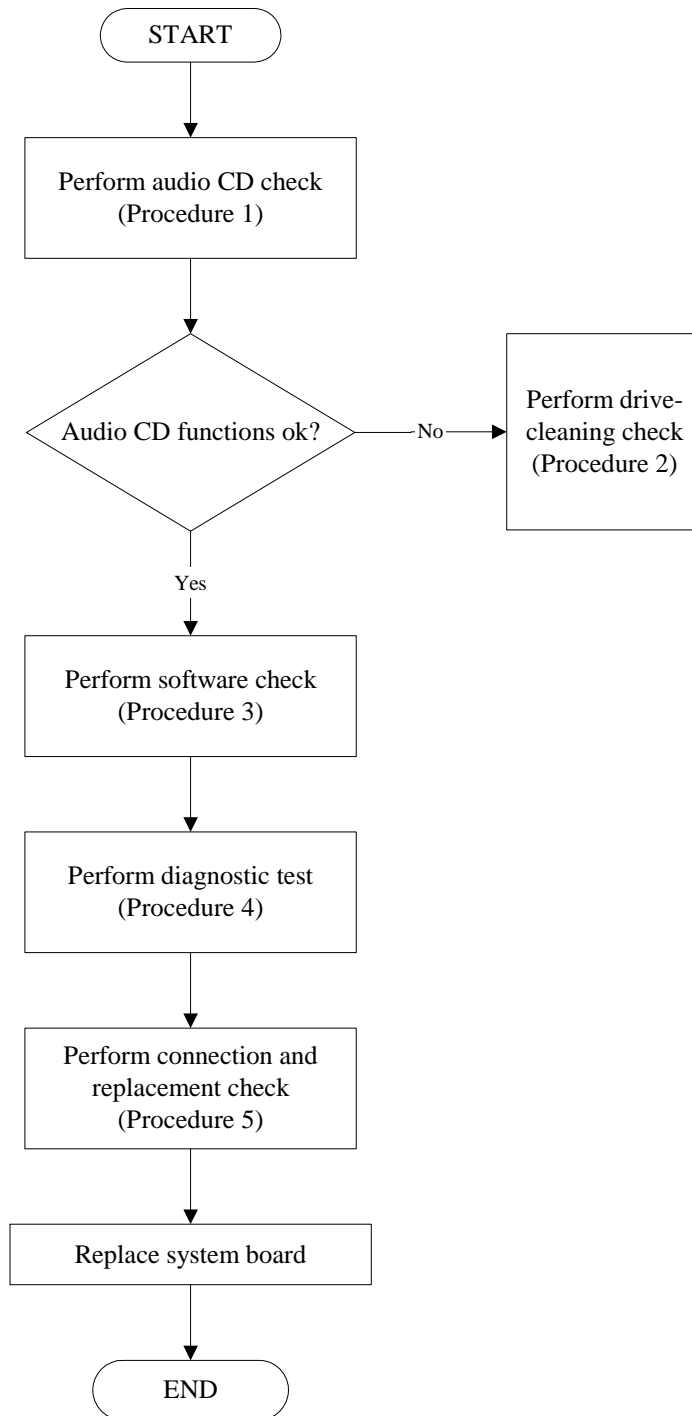

Figure 6-11 CD-ROM/DVD drive troubleshooting process

This section describes how to determine if the computer's internal DVD-ROM drive or CD-RW/DVD-ROM drive is functioning properly. Figure 6-11 outlines the process. Perform the steps below starting with Procedure 1 and continue with the other procedures as required.

Procedure 1: Audio CD test

Procedure 2: Drive cleaning check

Procedure 3: Software check

Procedure 4: Diagnostic test

Procedure 5: Connection and replacement check

Procedure 1 Audio CD check

First, insert an audio CD into the CD/DVD drive. If it works, the problem is not with the drive. Go to Procedure 3. If the audio CD does not work, go to Procedure 2. If the CD/DVD LED on the front panel does not light when the disc is played and the drive gives no response, go straight to Procedure 3.

Procedure 2 Drive cleaning check

Insert a CD/DVD drive-cleaning disk into the drive clean according to the drive-cleaning product instructions. If the problem persists, go to Procedure 3.

Procedure 3 Software check

Ensure that the appropriate driver has been installed on the computer for the CD/DVD drive.

Procedure 4 Diagnostic test

The CD-ROM/DVD-ROM test program stored in the Diagnostics Disk will test the drive's ability to play an audio CD, as well as the functions of the CD control buttons.

If any errors occur while executing the diagnostic program, go to Procedure 5.

Procedure 5 Connection check and replacement check

The DVD-ROM drive or the CD-RW/DVD-ROM drive connects to the system board. The drive may be disconnected, or the drive or system board may be damaged. Replacement Procedures and perform the following checks:

Check 1 Make sure the drive is firmly connected to the system board. If the connection is good and there is still an error, go to Check 2.

Check 2 The drive or drive cable may be defective or damaged. Replacement Procedures. If the drive is still not functioning properly, perform Check 3.

Check 3 The system board may be damaged.

Modem Troubleshooting

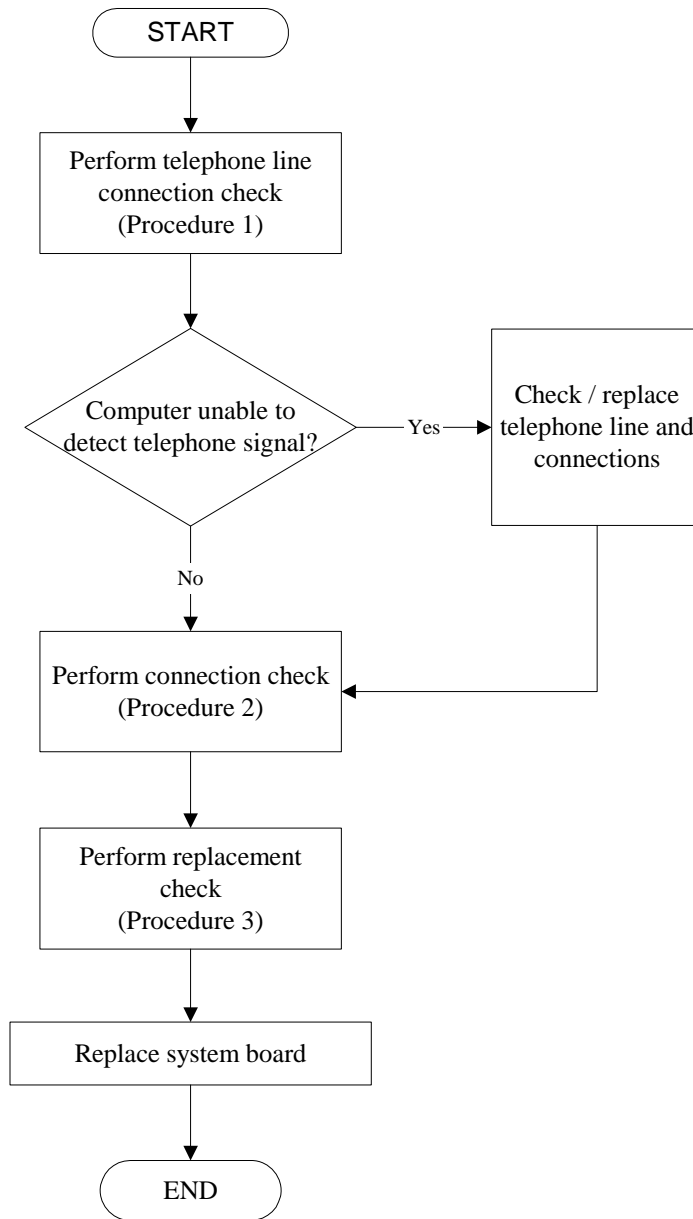

Figure 6-12 Modem troubleshooting process

This section describes how to determine if the computer's modem is functioning properly. Figure 6-12 outlines the process. Perform the steps below starting with Procedure 1 and continuing with the other procedures as required.

Procedure 1: Telephone line connection check

Procedure 2: Modem card connection check

Procedure 3: Modem card replacement check

Procedure 1 Telephone line connection check

The telephone cable may be damaged or the connections may be loose. Attempt to connect the computer to a network through using the modem. If the modem does not function at all, go to Procedure 3. If the attempt fails because the computer detects no telephone signal, the fault may be in the telephone cable, the wall socket or the modem port. Perform Check 1:

Check 1 Make sure telephone cable is firmly plugged into both the telephone wall socket and the modem port of the computer. If the cable is connected correctly, go to Check 2.

Check 2 Make sure the modem port is firmly secured to the system board of the computer. If the malfunction remains, go to Check 3.

Check 3 The telephone cable may be damaged. Replace with a good cable. If the malfunction remains, go to Procedure 2

Procedure 2 Modem card connection check

Disassemble the computer following the steps described *Replacement Procedures* and ensure that the modem card is well connected to the system board. If the problem persists, perform Procedure 3.

Procedure 3 Modem replacement check

The modem card or RJ-11 jack may be faulty. Try replacing them. If the problem persists, the system board may be defective or damaged. Replace the System Board with a new one following the steps *Replacement Procedures*.

PCMCIA Troubleshooting

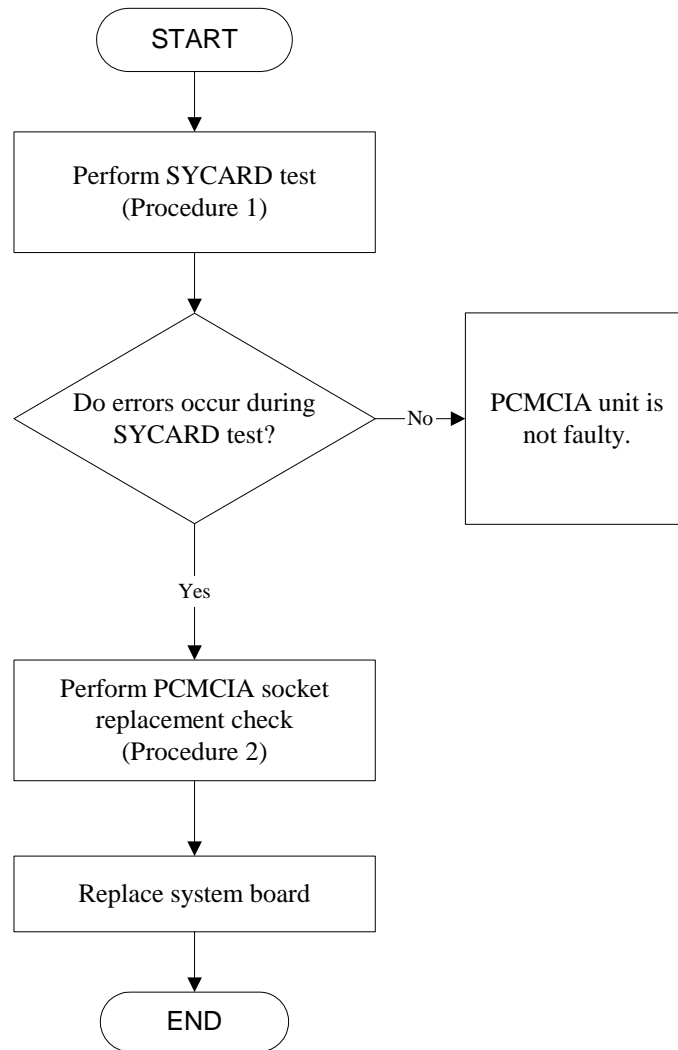

Figure 6-13 PCMCIA troubleshooting process

This section describes how to determine if the PCMCIA card player is functioning properly. The process is summarized in Figure 6-13. Perform the steps below starting with Procedure 1 and continuing with the other procedures as required.

Procedure 1: Sycard test

Procedure 2: PCMCIA socket replacement check

Procedure 1 SYCARD test

The SYCARD test card contains a PCMCIA test program. Ensure the card is fully inserted into the socket before running the program.

If an error occurs during the SYCARD test, perform Procedure 2. If no error occurs, it is likely that the original PC card was faulty.

Procedure 2 PCMCIA socket replacement check

The PCMCIA socket may be damaged or defective, for instance the socket pins can be bent. Disassemble the computer following the steps described in Chapter 4, Replacement Procedures and replace the socket. If the problem persists, the system board may be defective or damaged.

IEEE 1394 Troubleshooting

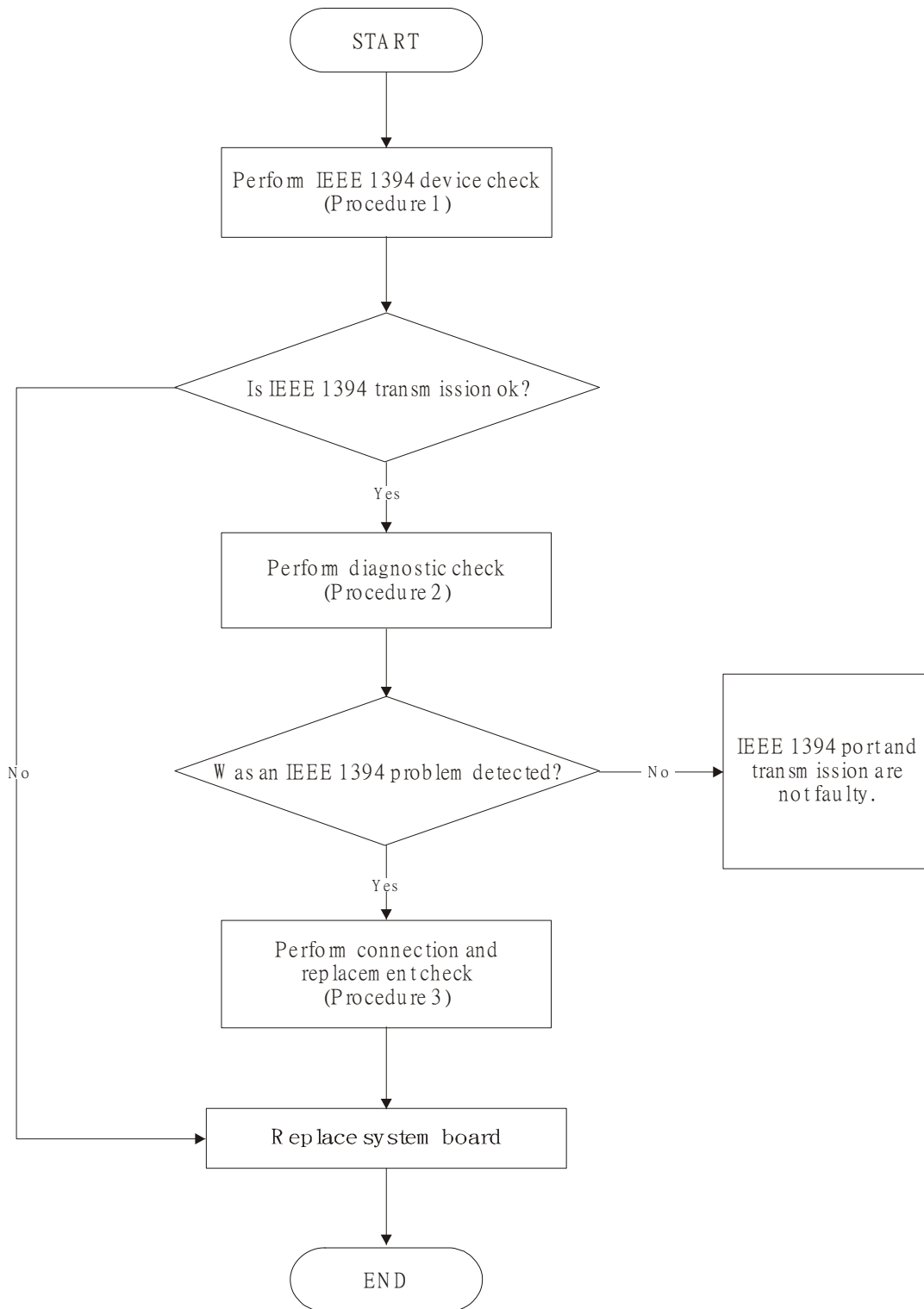

Figure 6-14 IEEE 1394 troubleshooting process

To determine if the computer's IEEE 1394 system is functioning properly, perform the following procedures. Figure 2-14 outlines the process. Start with Procedure 1 and continue with the other procedures as instructed.

Procedure 1: IEEE 1394 device check

Procedure 2: Diagnostic check

Procedure 3: Connection and replacement check

Procedure 1 IEEE 1394 device check

Connect an IEEE 1394 device to the computer's IEEE 1394 port, then boot the computer for Windows XP. The computer should automatically detect the 1394 device. Check whether the device can transmit data to the computer.

If the device is able to communicate with the computer, the problem may be intermittent or connections may be faulty. Go to Procedure 2.

If communication is impaired, there may be a faulty connection. Go to Procedure 3.

Procedure 2 Diagnostic check

Run the Diagnostic Program, which will automatically execute the IEEE 1394 port test to test transmission. Refer to Chapter 3, Tests and Diagnostics for more information on how to run the program.

If an error is located, go to Procedure 3. If an error does not occur, the 1394 port is functioning properly.

Procedure 3 Connection and replacement check

The transmission cable may be damaged or the connections may be loose. Perform Check 1:

- Check 1 Make sure the transmission cable is firmly plugged into both the IEEE 1394-compatible device and the IEEE 1394 port of the computer. If the cable is connected correctly, go to Check 2.
- Check 2 Make sure the IEEE 1394 port is firmly secured to the system board of the computer. If the malfunction persists, go to Check 3.
- Check 3 The transmission cable may be damaged. Replace with a good cable. If the malfunction persists, go to Check 4.
- Check 4 The system board may be damaged. Replace it with a new one following the instructions in Chapter 4.

Wireless LAN Troubleshooting

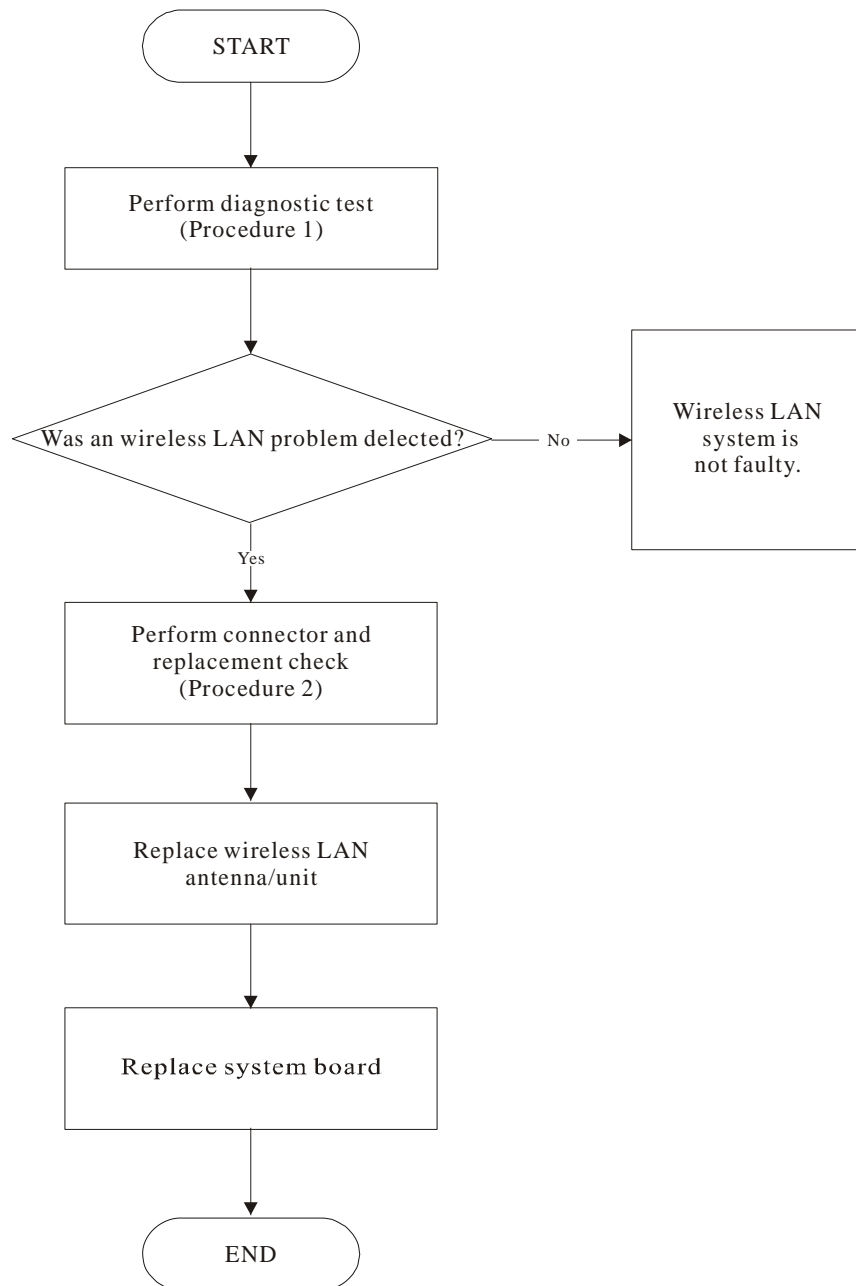

Figure 6-15 Wireless LAN troubleshooting process

The wireless LAN antenna wire, wireless LAN unit or system board may each be the source of a wireless LAN fault. Any of these components may be damaged. To determine if the computer's wireless LAN system is functioning properly, perform the following procedures. Figure 2-15 outlines the process. Start with Procedure 1 and continue with the other procedures as instructed.

Procedure 1: Diagnostic test

Procedure 2: Connector and replacement check

Procedure 1 Diagnostic test

Run the Diagnostic Program, which will automatically execute the wireless LAN test. Refer to Chapter 3, Tests and Diagnostics for more information on the program. If an error is located, go to Procedure 2. If an error is not located, the wireless LAN system is functioning properly.

Procedure 2 Connector and replacement check

The wireless LAN antenna, wireless LAN unit or system board may be disconnected or damaged. Disassemble the computer following the steps described in Chapter 4, *Replacement Procedures*, and perform the following checks.

- Check 1 Make sure that the wireless LAN antenna is firmly connected to the wireless LAN unit (refer to Chapter 4 for instructions) and that the wireless LAN unit is securely slotted into the system board. If the problem persists, go to Check 2.
- Check 2 Check that the wireless communication switch is turned to "On", then make sure that the wireless communication LED on the front panel is lit. If the LED is lit but the wireless LAN function is still faulty, the antenna may be damaged. Replace with a new antenna following the steps in Chapter 4, *Replacement Procedures*. If the problem persists, or if the wireless LAN LED is not lit when the wireless communication switch is turned to "On", go to Check 3.
- Check 3 The wireless LAN unit may be damaged. Replace it with a new one following the instructions in Chapter 4. If the problem still exists, perform Check 4.
- Check 4 The system board may be damaged. Replace it with a new one following the instructions in Chapter

Material List by Single-Item/Single-Level

Date : 05-07-2002
 Time : 11:02:16
 Plant: TW01
 Report by UID: 8746109

Drawing No: ACY25
 Revision: 1A

C NO	PART NO	DESCRIPTION	QUANTITY REQUIRED	LOCATION
			25D01	
#	ACY25D01	FG 030 14.1" XGA TEST	REF - - - -	
001	AB805320010	IC RH80532GC021512 B 1.5G UFCPGA	1	001
002	AB805320030	IC RH80532GC021512B0 1.5G FCPGA2	1	001
003	AB805320110	IC RH80532GC025512 B 1.6G UFCPGA	1	001
004	AB805320130	IC RH80532GC025512B0 1.6G FCPGA2	1	001
005	AB805320210	IC RH80532GC017512 B 1.4G UFCPGA	1	001
006	AB805320230	IC RH80532GC017512B0 1.4G FCPGA2	1	001
007	AB805320320	IC RH80532GC013512B0 1.3G FCPGA2	1	001
008	AB805320410	IC RH80532GC029512 B 1.7G UFCPGA	1	001
009	AB805320430	IC RH80532GC029512B0 1.7G FCPGA2	1	001
010	AB805320800	IC TST RH80532GC033512S 1.8PCPGA A31	1	001
011	AB805320810	IC RH80532GC033512B 1.8G UFCPGA	1	001
012	DD100020000	HDD 20G 2.75"W .37"H MK2018GAP	1	002
013	DD100020100	HDD 40G 2.75"W .37"H MK4018GAP	1	002
014	DD100020300	HDD 30G 2.75"W .37"H MK3018GAP	1	002
015	DD100020500	HDD 20G 2.75"W .37"H DK23DA-20F	1	002
016	DD100020600	HDD 30G 2.75"W .37"H DK23DA-30F	1	002
017	DD100020700	HDD 40G 2.75"W .37"H DK23DA-40F	1	002
018	DD100020900	HDD 20G .37"H IC25N020ATCS04-0	1	002
019	DD100021000	HDD 30G .37"H IC25N030ATCS04-0	1	002
020	DD100021100	HDD 40G .37"H IC25N040ATCS04-0	1	002
021	GA020120605	PWR CORD SP021AX1.8MXIS033 H03 BLK	1	003
022	GA020260000	PWR CORD LP21X1.8MXLS7 EC 2P L	1	003
023	GA040060100	PWR CORD LP60LX1.8MXLS7 UK 2P L	1	003
024	GA040100000	PWR CORD SP61*1.8M*IS037 H03 BLK UK	1	003
025	GA050070100	PWR CORD SP12NX1.8MXIS033 SPT-2 BLK	1	003
026	GA050100000	PWR CORD LP5X1.8MXLS7C US 2P L	1	003
027	GA060040009	PWR CORD SP501X1.8MXIS033 2LDF BLK	1	003
028	GA060090000	PWR CORD LP15AX1.8MXLS7 AUS 2P L	1	003
029	GA090020000	PWR CORD SP505X1.8MXIS033 RVV2C BLK	1	003
030	GA090040000	PWR CORD PC205X1.8XCOC03 CHI 2P L	1	003
031	GC86508PA30	BATT CGR18650A LI-ION 3.9AH 30N3	1	004
032	GC86508SM20	BATT ICR18650 LI-ION 3.9AH 30N3	1	004
033	PK100006400	AC ADAP ASTEC SA80-3105-2278 70W 2P	1	005
034	PK100007000	AC ADAP LITEON PA-1750-01CA 75W 2P A30	1	005
035	PK051000340	DDR MODU HYN HYMD116M645A6-H 128M/266	1	006
036	PK051000820	DDR MODU SAM M470L1624BT0-CB0 128M/266	1	006
037	PK051001500	DDR MODU NAN NT128D64S88A2GM-7K 128/266	1	006
038	PK051002000	DDR MODU APACER 77.10921.580 128M/266	1	006
039	PK051020320	DDR MODU SAM M470L3224BT0-CB0 256/266	1	006
040	PK051020820	DDR MODU HYN HYMD232M6466-H 256M/266	1	006
041	PK051021100	DDR MODU NAN NT256D64S88A2GM-7K 256/266	1	006
042	PK051021300	DDR MODU MIT MH32D64KQH-75 256M/266	1	006
043	PK051021700	DDR MODU APACER 77.11021.580 256M/266	1	006
044	PK051030010	DDR MODU SAM M470L6423CK0-CB0 512/266	1	006
045	PK051030500	DDR MODU MIT MH64D64AKQH-75 512M/266	1	006
046	PK13CY250AR	K/B PACK CHICONY ACY25 AR-E REV00 A30	1	101
047	PK13CY250BE	K/B PACK CHICONY ACY25 BE REV00 A30	1	101
048	PK13CY250CF	K/B PACK CHICONY ACY25 CF REV00 A30	1	101
049	PK13CY250CH	K/B PACK CHICONY ACY25 CH REV00 A30	1	101
050	PK13CY250CZ	K/B PACK CHICONY ACY25 CZ REV00 A30	1	101
051	PK13CY250DM	K/B PACK CHICONY ACY25 DM REV00 A30	1	101

Material List by Single-Item/Single-Level

Date : 05-07-2002
 Time : 11:02:16
 Plant: TW01
 Report by UID: 8746109

Drawing No: ACY25
 Revision: 1A

C NO	PART NO	DESCRIPTION	QUANTITY REQUIRED	LOCATION
			25D01	
052	PK13CY250FR	K/B PACK CHICONY ACY25 FR REV00 A30	1	101
053	PK13CY250GR	K/B PACK CHICONY ACY25 GR REV00 A30	1	101
054	PK13CY250HG	K/B PACK CHICONY ACY25 HG REV00 A30	1	101
055	PK13CY250IT	K/B PACK CHICONY ACY25 IT REV00 A30	1	101
056	PK13CY250JA	K/B PACK CHICONY ACY25 JA REV00 A30	1	101
057	PK13CY250KO	K/B PACK CHICONY ACY25 KO REV00 A30	1	101
058	PK13CY250NW	K/B PACK CHICONY ACY25 NW REV00 A30	1	101
059	PK13CY250PO	K/B PACK CHICONY ACY25 PO REV00 A30	1	101
060	PK13CY250RU	K/B PACK CHICONY ACY25 RU REV00 A30	1	101
061	PK13CY250SD	K/B PACK CHICONY ACY25 SD REV00 A30	1	101
062	PK13CY250SP	K/B PACK CHICONY ACY25 SP REV00 A30	1	101
063	PK13CY250SW	K/B PACK CHICONY ACY25 SW REV00 A30	1	101
064	PK13CY250TI	K/B PACK CHICONY ACY25 TI REV00 A30	1	101
065	PK13CY250TR	K/B PACK CHICONY ACY25 TR REV00 A30	1	101
066	PK13CY250UK	K/B PACK CHICONY ACY25 UK REV00 A30	1	101
067	PK13CY250US	K/B PACK CHICONY ACY25 US REV00 A30	1	101
068	54B60130001	SYS UNIT ACY25-030 W/WLAN	1	251
069	54B60130002	SYS UNIT ACY25-030 W/O WLAN	1	251
070	51085630001	LCD ASSY ACY25 14.1"-AU	1	252
071	51085630002	LCD ASSY ACY25 14.1"-CPT	1	252
072	51085530001	COMBO ASSY ACY25 TOS-8X(SD-R2102)	1	253
073	51085530002	COMBO ASSY ACY25 KME-8X (UJDA720)	1	253
074	51085530003	COMBO ASSY ACY25 HLDS-8X(GCC-4080)	1	253
075	51085530004	COMBO ASSY ACY25 AVC (SD-R2102)	1	253
076	51085530005	COMBO ASSY ACY25-16X SHP(SD-R2212)	1	253
077	51085530006	COMBO ASSY ACY25-16X MIT(SD-R2212)	1	253
078	51085530007	COMBO ASSY ACY25-16X TOS(SD-R2212)	1	253
079	51085530008	COMBO ASSY ACY25-16X KME(UJDA730)	1	253
080	51085030001	HDD ASSY ACY25 (W/O HDD)	1	254
081	51085130001	FDD ASSY ACY25 PAN	1	255
082	51085130002	FDD ASSY ACY25 MTM	1	255
083	51085230001	CD-ROM ASSY ACY25 QSI-24X	1	256
084	51085230002	CD-ROM ASSY ACY25 SAM-24X	1	256
085	51085330001	DVD ASSY ACY25 TOS-SHARP 8X	1	257
086	51085330002	DVD ASSY ACY25 HLDS-8X	1	257
087	51085330003	DVD ASSY ACY25 LITE-8X	1	257
088	51085330004	DVD ASSY ACY25 TOS-AVC 8X	1	257
089	51085330005	DVD ASSY ACY25 TOS-2502 8X	1	257
090	51085430001	CD-RW ASSY ACY25 KME-8X	1	258
091	51085430002	CD-RW ASSY ACY25 TOS-16X	1	258
092	64005130003	PACKING 030 N30N3-030 14.1(TEST)	1	300
093	X6684630002	INTEL LABEL N30N3 FOR PIII CPU	1	400

Material List by Single-Item/Single-Level

Date : 05-07-2002
 Time : 11:02:16
 Plant: TW01
 Report by UID: 8746109

Drawing No: ACY25
 Revision: 1A

C NO	PART NO	DESCRIPTION	QUANTITY REQUIRED	LOCATION
	ACY25F01	FG 030 15" XGA TEST	25F01	
#	ACY25F01	FG 030 15" XGA TEST	REF - - - -	
001	AB805320010	IC RH80532GC021512 B 1.5G UFCPGA	1	001
002	AB805320030	IC RH80532GC021512B0 1.5G FCPGA2	1	001
003	AB805320110	IC RH80532GC025512 B 1.6G UFCPGA	1	001
004	AB805320130	IC RH80532GC025512B0 1.6G FCPGA2	1	001
005	AB805320210	IC RH80532GC017512 B 1.4G UFCPGA	1	001
006	AB805320230	IC RH80532GC017512B0 1.4G FCPGA2	1	001
007	AB805320320	IC RH80532GC013512B0 1.3G FCPGA2	1	001
008	AB805320410	IC RH80532GC029512 B 1.7G UFCPGA	1	001
009	AB805320430	IC RH80532GC029512B0 1.7G FCPGA2	1	001
010	AB805320800	IC TST RH80532GC033512S 1.8PCPGA A31	1	001
011	AB805320810	IC RH80532GC033512B 1.8G UFCPGA	1	001
012	DD100020000	HDD 20G 2.75"W .37"H MK2018GAP	1	002
013	DD100020100	HDD 40G 2.75"W .37"H MK4018GAP	1	002
014	DD100020300	HDD 30G 2.75"W .37"H MK3018GAP	1	002
015	DD100020500	HDD 20G 2.75"W .37"H DK23DA-20F	1	002
016	DD100020600	HDD 30G 2.75"W .37"H DK23DA-30F	1	002
017	DD100020700	HDD 40G 2.75"W .37"H DK23DA-40F	1	002
018	DD100020900	HDD 20G .37"H IC25N020ATCS04-0	1	002
019	DD100021000	HDD 30G .37"H IC25N030ATCS04-0	1	002
020	DD100021100	HDD 40G .37"H IC25N040ATCS04-0	1	002
021	GA020120605	PWR CORD SP021AX1.8MXIS033 H03 BLK	1	003
022	GA020260000	PWR CORD LP21X1.8MXLS7 EC 2P L	1	003
023	GA040060100	PWR CORD LP60LX1.8MXLS7 UK 2P L	1	003
024	GA040100000	PWR CORD SP61*1.8M*IS037 H03 BLK UK	1	003
025	GA050070100	PWR CORD SP12NX1.8MXIS033 SPT-2 BLK	1	003
026	GA050100000	PWR CORD LP5X1.8MXLS7C US 2P L	1	003
027	GA060040009	PWR CORD SP501X1.8MXIS033 2LDF BLK	1	003
028	GA060090000	PWR CORD LP15AX1.8MXLS7 AUS 2P L	1	003
029	GA090020000	PWR CORD SP505X1.8MXIS033 RVV2C BLK	1	003
030	GA090040000	PWR CORD PC205X1.8XCOC03 CHI 2P L	1	003
031	GC86508PA30	BATT CGR18650A LI-ION 3.9AH 30N3	1	004
032	GC86508SM20	BATT ICR18650 LI-ION 3.9AH 30N3	1	004
033	PK100006400	AC ADAP ASTEC SA80-3105-2278 70W 2P	1	005
034	PK100007000	AC ADAP LITEON PA-1750-01CA 75W 2P A30	1	005
035	PK051000340	DDR MODU HYN HYMD116M645A6-H 128M/266	1	006
036	PK051000820	DDR MODU SAM M470L1624BT0-CB0 128M/266	1	006
037	PK051001500	DDR MODU NAN NT128D64S88A2GM-7K 128/266	1	006
038	PK051002000	DDR MODU APACER 77.10921.580 128M/266	1	006
039	PK051020320	DDR MODU SAM M470L3224BT0-CB0 256/266	1	006
040	PK051020820	DDR MODU HYN HYMD232M6466-H 256M/266	1	006
041	PK051021100	DDR MODU NAN NT256D64S88A2GM-7K 256/266	1	006
042	PK051021300	DDR MODU MIT MH32D64KQH-75 256M/266	1	006
043	PK051021700	DDR MODU APACER 77.11021.580 256M/266	1	006
044	PK051030010	DDR MODU SAM M470L6423CK0-CB0 512/266	1	006
045	PK051030500	DDR MODU MIT MH64D64AKQH-75 512M/266	1	006
046	PK13CY250AR	K/B PACK CHICONY ACY25 AR-E REV00 A30	1	101
047	PK13CY250BE	K/B PACK CHICONY ACY25 BE REV00 A30	1	101
048	PK13CY250CF	K/B PACK CHICONY ACY25 CF REV00 A30	1	101
049	PK13CY250CH	K/B PACK CHICONY ACY25 CH REV00 A30	1	101
050	PK13CY250CZ	K/B PACK CHICONY ACY25 CZ REV00 A30	1	101
051	PK13CY250DM	K/B PACK CHICONY ACY25 DM REV00 A30	1	101

Material List by Single-Item/Single-Level

Date : 05-07-2002
 Time : 11:02:16
 Plant: TW01
 Report by UID: 8746109

Drawing No: ACY25
 Revision: 1A

C NO	PART NO	DESCRIPTION	QUANTITY REQUIRED	LOCATION
			25F01	
052	PK13CY250FR	K/B PACK CHICONY ACY25 FR REV00 A30	1	101
053	PK13CY250GR	K/B PACK CHICONY ACY25 GR REV00 A30	1	101
054	PK13CY250HG	K/B PACK CHICONY ACY25 HG REV00 A30	1	101
055	PK13CY250IT	K/B PACK CHICONY ACY25 IT REV00 A30	1	101
056	PK13CY250JA	K/B PACK CHICONY ACY25 JA REV00 A30	1	101
057	PK13CY250KO	K/B PACK CHICONY ACY25 KO REV00 A30	1	101
058	PK13CY250NW	K/B PACK CHICONY ACY25 NW REV00 A30	1	101
059	PK13CY250PO	K/B PACK CHICONY ACY25 PO REV00 A30	1	101
060	PK13CY250RU	K/B PACK CHICONY ACY25 RU REV00 A30	1	101
061	PK13CY250SD	K/B PACK CHICONY ACY25 SD REV00 A30	1	101
062	PK13CY250SP	K/B PACK CHICONY ACY25 SP REV00 A30	1	101
063	PK13CY250SW	K/B PACK CHICONY ACY25 SW REV00 A30	1	101
064	PK13CY250TI	K/B PACK CHICONY ACY25 TI REV00 A30	1	101
065	PK13CY250TR	K/B PACK CHICONY ACY25 TR REV00 A30	1	101
066	PK13CY250UK	K/B PACK CHICONY ACY25 UK REV00 A30	1	101
067	PK13CY250US	K/B PACK CHICONY ACY25 US REV00 A30	1	101
068	54B60130001	SYS UNIT ACY25-030 W/WLAN	1	251
069	54B60130002	SYS UNIT ACY25-030 W/O WLAN	1	251
070	51085630011	LCD ASSY ACY25 15"-AU (XGA)	1	252
071	51085630012	LCD ASSY ACY25 15"-LG (XGA)	1	252
072	51085630013	LCD ASSY ACY25 15"-HIT (XGA)	1	252
073	51085530001	COMBO ASSY ACY25 TOS-8X(SD-R2102)	1	253
074	51085530002	COMBO ASSY ACY25 KME-8X (UJDA720)	1	253
075	51085530003	COMBO ASSY ACY25 HLDS-8X(GCC-4080)	1	253
076	51085530004	COMBO ASSY ACY25 AVC (SD-R2102)	1	253
077	51085530005	COMBO ASSY ACY25-16X SHP(SD-R2212)	1	253
078	51085530006	COMBO ASSY ACY25-16X MIT(SD-R2212)	1	253
079	51085530007	COMBO ASSY ACY25-16X TOS(SD-R2212)	1	253
080	51085530008	COMBO ASSY ACY25-16X KME(UJDA730)	1	253
081	51085030001	HDD ASSY ACY25 (W/O HDD)	1	254
082	51085130001	FDD ASSY ACY25 PAN	1	255
083	51085130002	FDD ASSY ACY25 MTM	1	255
084	51085230001	CD-ROM ASSY ACY25 QSI-24X	1	256
085	51085230002	CD-ROM ASSY ACY25 SAM-24X	1	256
086	51085330001	DVD ASSY ACY25 TOS-SHARP 8X	1	257
087	51085330002	DVD ASSY ACY25 HLDS-8X	1	257
088	51085330003	DVD ASSY ACY25 LITE-8X	1	257
089	51085330004	DVD ASSY ACY25 TOS-AVC 8X	1	257
090	51085330005	DVD ASSY ACY25 TOS-2502 8X	1	257
091	51085430001	CD-RW ASSY ACY25 KME-8X	1	258
092	51085430002	CD-RW ASSY ACY25 TOS-16X	1	258
093	64005130003	PACKING 030 N30N3-030 14.1(TEST)	1	300
094	X6684630002	INTEL LABEL N30N3 FOR PIII CPU	1	400

Material List by Single-Item/Single-Level

Date : 05-07-2002
 Time : 11:02:16
 Plant: TW01
 Report by UID: 8746109

Drawing No: ACY25
 Revision: 1A

C NO	PART NO	DESCRIPTION	QUANTITY REQUIRED	LOCATION
	25G01			
#	ACY25G01	FG 030 15" SXGA TEST	REF - - - -	
001	AB805320010	IC RH80532GC021512 B 1.5G UFCPGA	1	001
002	AB805320030	IC RH80532GC021512B0 1.5G FCPGA2	1	001
003	AB805320110	IC RH80532GC025512 B 1.6G UFCPGA	1	001
004	AB805320130	IC RH80532GC025512B0 1.6G FCPGA2	1	001
005	AB805320210	IC RH80532GC017512 B 1.4G UFCPGA	1	001
006	AB805320230	IC RH80532GC017512B0 1.4G FCPGA2	1	001
007	AB805320320	IC RH80532GC013512B0 1.3G FCPGA2	1	001
008	AB805320410	IC RH80532GC029512 B 1.7G UFCPGA	1	001
009	AB805320430	IC RH80532GC029512B0 1.7G FCPGA2	1	001
010	AB805320800	IC TST RH80532GC033512S 1.8PCPGA A31	1	001
011	AB805320810	IC RH80532GC033512B 1.8G UFCPGA	1	001
012	DD100020000	HDD 20G 2.75"W .37"H MK2018GAP	1	002
013	DD100020100	HDD 40G 2.75"W .37"H MK4018GAP	1	002
014	DD100020300	HDD 30G 2.75"W .37"H MK3018GAP	1	002
015	DD100020500	HDD 20G 2.75"W .37"H DK23DA-20F	1	002
016	DD100020600	HDD 30G 2.75"W .37"H DK23DA-30F	1	002
017	DD100020700	HDD 40G 2.75"W .37"H DK23DA-40F	1	002
018	DD100020900	HDD 20G .37"H IC25N020ATCS04-0	1	002
019	DD100021000	HDD 30G .37"H IC25N030ATCS04-0	1	002
020	DD100021100	HDD 40G .37"H IC25N040ATCS04-0	1	002
021	GA020120605	PWR CORD SP021AX1.8MXIS033 H03 BLK	1	003
022	GA020260000	PWR CORD LP21X1.8MXLS7 EC 2P L	1	003
023	GA040060100	PWR CORD LP60LX1.8MXLS7 UK 2P L	1	003
024	GA040100000	PWR CORD SP61*1.8M*IS037 H03 BLK UK	1	003
025	GA050070100	PWR CORD SP12NX1.8MXIS033 SPT-2 BLK	1	003
026	GA050100000	PWR CORD LP5X1.8MXLS7C US 2P L	1	003
027	GA060040009	PWR CORD SP501X1.8MXIS033 2LDF BLK	1	003
028	GA060090000	PWR CORD LP15AX1.8MXLS7 AUS 2P L	1	003
029	GA090020000	PWR CORD SP505X1.8MXIS033 RVV2C BLK	1	003
030	GA090040000	PWR CORD PC205X1.8XCOC03 CHI 2P L	1	003
031	GC86508PA30	BATT CGR18650A LI-ION 3.9AH 30N3	1	004
032	GC86508SM20	BATT ICR18650 LI-ION 3.9AH 30N3	1	004
033	PK100006400	AC ADAP ASTEC SA80-3105-2278 70W 2P	1	005
034	PK100007000	AC ADAP LITEON PA-1750-01CA 75W 2P A30	1	005
035	PK051000340	DDR MODU HYN HYMD116M645A6-H 128M/266	1	006
036	PK051000820	DDR MODU SAM M470L1624BT0-CB0 128M/266	1	006
037	PK051001500	DDR MODU NAN NT128D64S88A2GM-7K 128/266	1	006
038	PK051002000	DDR MODU APACER 77.10921.580 128M/266	1	006
039	PK051020320	DDR MODU SAM M470L3224BT0-CB0 256/266	1	006
040	PK051020820	DDR MODU HYN HYMD232M6466-H 256M/266	1	006
041	PK051021100	DDR MODU NAN NT256D64S88A2GM-7K 256/266	1	006
042	PK051021300	DDR MODU MIT MH32D64KQH-75 256M/266	1	006
043	PK051021700	DDR MODU APACER 77.11021.580 256M/266	1	006
044	PK051030010	DDR MODU SAM M470L6423CK0-CB0 512/266	1	006
045	PK051030500	DDR MODU MIT MH64D64AKQH-75 512M/266	1	006
046	PK13CY250AR	K/B PACK CHICONY ACY25 AR-E REV00 A30	1	101
047	PK13CY250BE	K/B PACK CHICONY ACY25 BE REV00 A30	1	101
048	PK13CY250CF	K/B PACK CHICONY ACY25 CF REV00 A30	1	101
049	PK13CY250CH	K/B PACK CHICONY ACY25 CH REV00 A30	1	101
050	PK13CY250CZ	K/B PACK CHICONY ACY25 CZ REV00 A30	1	101
051	PK13CY250DM	K/B PACK CHICONY ACY25 DM REV00 A30	1	101

Material List by Single-Item/Single-Level

Date : 05-07-2002
 Time : 11:02:16
 Plant: TW01
 Report by UID: 8746109

Drawing No: ACY25
 Revision: 1A

C NO	PART NO	DESCRIPTION	QUANTITY REQUIRED	LOCATION
			25G01	
052	PK13CY250FR	K/B PACK CHICONY ACY25 FR REV00 A30	1	101
053	PK13CY250GR	K/B PACK CHICONY ACY25 GR REV00 A30	1	101
054	PK13CY250HG	K/B PACK CHICONY ACY25 HG REV00 A30	1	101
055	PK13CY250IT	K/B PACK CHICONY ACY25 IT REV00 A30	1	101
056	PK13CY250JA	K/B PACK CHICONY ACY25 JA REV00 A30	1	101
057	PK13CY250KO	K/B PACK CHICONY ACY25 KO REV00 A30	1	101
058	PK13CY250NW	K/B PACK CHICONY ACY25 NW REV00 A30	1	101
059	PK13CY250PO	K/B PACK CHICONY ACY25 PO REV00 A30	1	101
060	PK13CY250RU	K/B PACK CHICONY ACY25 RU REV00 A30	1	101
061	PK13CY250SD	K/B PACK CHICONY ACY25 SD REV00 A30	1	101
062	PK13CY250SP	K/B PACK CHICONY ACY25 SP REV00 A30	1	101
063	PK13CY250SW	K/B PACK CHICONY ACY25 SW REV00 A30	1	101
064	PK13CY250TI	K/B PACK CHICONY ACY25 TI REV00 A30	1	101
065	PK13CY250TR	K/B PACK CHICONY ACY25 TR REV00 A30	1	101
066	PK13CY250UK	K/B PACK CHICONY ACY25 UK REV00 A30	1	101
067	PK13CY250US	K/B PACK CHICONY ACY25 US REV00 A30	1	101
068	54B60130001	SYS UNIT ACY25-030 W/WLAN	1	251
069	54B60130002	SYS UNIT ACY25-030 W/O WLAN	1	251
070	51085630021	LCD ASSY ACY25 15"-CPT (SXGA)	1	252
071	51085630022	LCD ASSY ACY25 15"-LG (SXGA)	1	252
072	51085630023	LCD ASSY ACY25 15"-IBM (SXGA)	1	252
073	51085530001	COMBO ASSY ACY25 TOS-8X(SD-R2102)	1	253
074	51085530002	COMBO ASSY ACY25 KME-8X (UJDA720)	1	253
075	51085530003	COMBO ASSY ACY25 HLDS-8X(GCC-4080)	1	253
076	51085530004	COMBO ASSY ACY25 AVC (SD-R2102)	1	253
077	51085530005	COMBO ASSY ACY25-16X SHP(SD-R2212)	1	253
078	51085530006	COMBO ASSY ACY25-16X MIT(SD-R2212)	1	253
079	51085530007	COMBO ASSY ACY25-16X TOS(SD-R2212)	1	253
080	51085530008	COMBO ASSY ACY25-16X KME(UJDA730)	1	253
081	51085030001	HDD ASSY ACY25 (W/O HDD)	1	254
082	51085130001	FDD ASSY ACY25 PAN	1	255
083	51085130002	FDD ASSY ACY25 MTM	1	255
084	51085230001	CD-ROM ASSY ACY25 QSI-24X	1	256
085	51085230002	CD-ROM ASSY ACY25 SAM-24X	1	256
086	51085330001	DVD ASSY ACY25 TOS-SHARP 8X	1	257
087	51085330002	DVD ASSY ACY25 HLDS-8X	1	257
088	51085330003	DVD ASSY ACY25 LITE-8X	1	257
089	51085330004	DVD ASSY ACY25 TOS-AVC 8X	1	257
090	51085330005	DVD ASSY ACY25 TOS-2502 8X	1	257
091	51085430001	CD-RW ASSY ACY25 KME-8X	1	258
092	51085430002	CD-RW ASSY ACY25 TOS-16X	1	258
093	64005130003	PACKING 030 N30N3-030 14.1(TEST)	1	300
094	X6684630002	INTEL LABEL N30N3 FOR PIII CPU	1	400

END OF REPORT

Material List by Single-Item/Single-Level

Date : 05-02-2002
 Time : 15:12:42
 Plant: TW01
 Report by UID: 8746109

Drawing No: 510850
 Revision: 1A

C NO	PART NO	DESCRIPTION	QUANTITY REQUIRED	LOCATION
			30001	
#	51085030001	HDD ASSY ACY25 (W/O HDD)	REF - - - -	
001	MAAA4303000	SCREW M3.0X0.8+3K-NL	4	001
002	EECY2538100	ACY25 HDD BRK COVER	1	002
003	APCY257T100	ACY25_HDD_DOOR_ASSY	1	003
004	DC040011210	SOCKET CONN. AFH-22SD2 44P OCTEKCONN	1	010

END OF REPORT

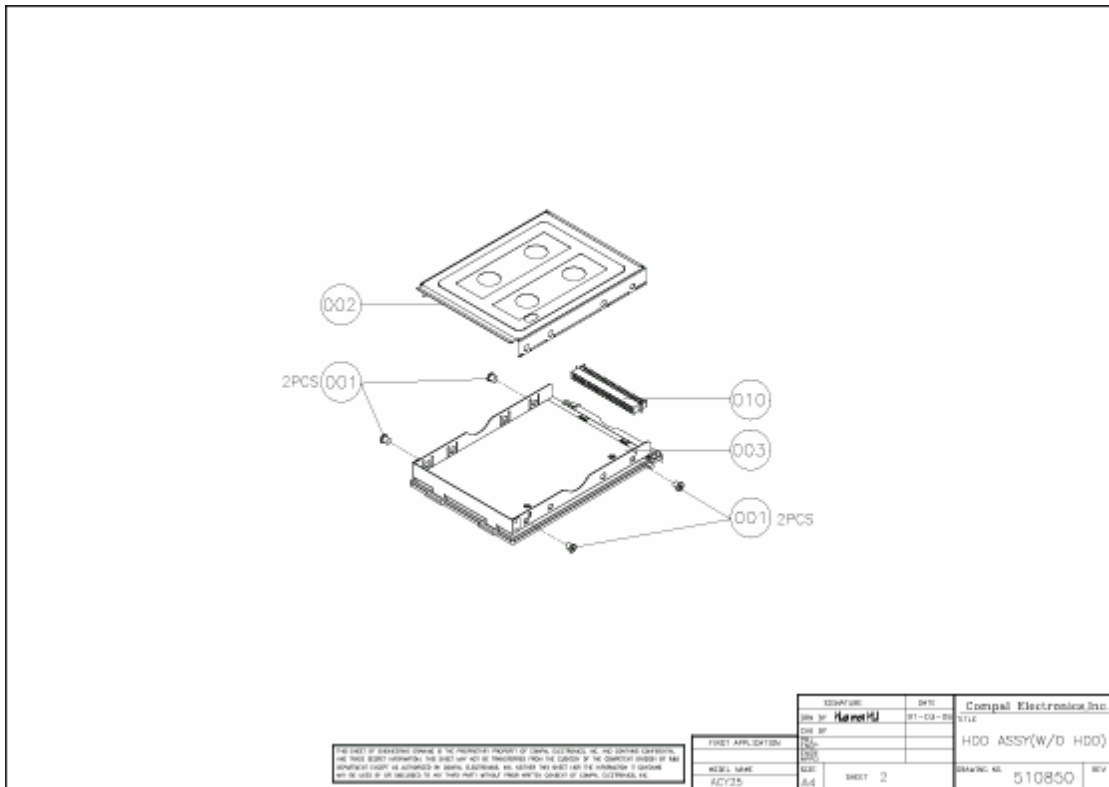

<small>THIS SHEET OF DRAWINGS REMAINS THE PROPERTY OF COMPAQ ELECTRONICS, INC. NO LOANING, REPRODUCTION, OR DISSEMINATION OF THIS SHEET OR THE INFORMATION THEREON IS TO BE MADE TO ANY OTHER PERSON OR ENTITY WITHOUT THE WRITTEN PERMISSION OF COMPAQ ELECTRONICS, INC. ANY UNAUTHORIZED USE OF THIS SHEET OR THE INFORMATION THEREON IS PROHIBITED.</small>	FIRST APPLICATION DATE BY	DATE OF ISSUE BY	COMPANY TITLE
	MODEL NAME ACY25	SIZE 6.4	SHEET 2

Material List by Single-Item/Single-Level

Date : 05-07-2002
 Time : 08:43:09
 Plant: TW01
 Report by UID: 8746109

Drawing No: 510851
 Revision: 1B

C NO PART NO DESCRIPTION QUANTITY REQUIRED LOCATION
 30001 30002

#	51085130001	FDD ASSY ACY25 PAN	REF	-	-	-	-
#	51085130002	FDD ASSY ACY25 MTM	-	REF	-	-	-
001	MAAA0203000	SCREW M2.0X0.4+3K-ZK	-	4			001
002	MAC925003Z0	SCREW M2.5_9_5.5*0.8_03_R00	3	-			001
003	FACY2532100	ACY25 FDD PANEL MIM	-	1			002
004	FACY2534100	ACY25 FDD PANEL PASC	1	-			002
005	ECCY2533100	ACY25 FDD BRK MIM	-	1			003
006	ECCY2535100	ACY25 FDD BRK PASC	1	-			003
007	MAAA0203000	SCREW M2.0X0.4+3K-ZK	1	-			004
* 008	DA3CY25L010	FPC ACY25 LF-1344 REV1 PANNAS.FDD	1	-			010
* 009	DA3CY25L110	FPC ACY25 LF-1345 REV1 MITSUMI FDD	-	1			010
010	DD000005140	FDD 1.44M 4"W .5"H JU-226A273FC	1	-			011
011	DD000005220	FDD 1.44M 4"W .5"H D353G-2938	-	1			011

END OF REPORT

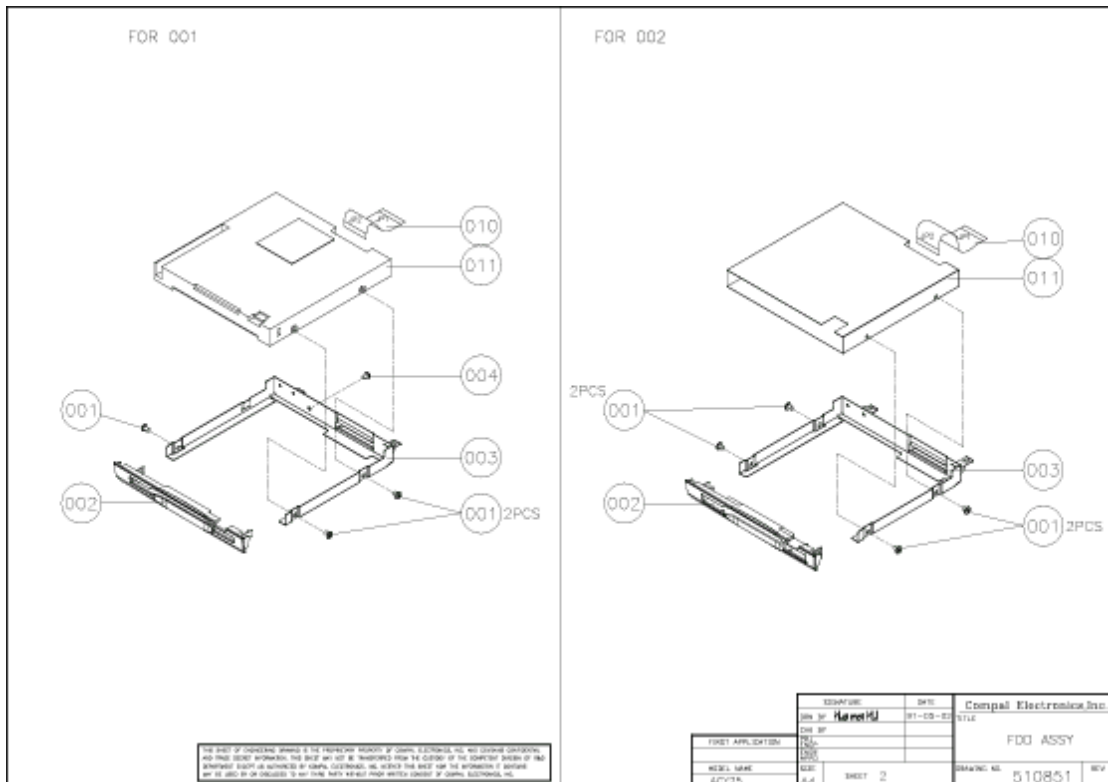

Material List by Single-Item/Single-Level

Date : 05-02-2002
 Time : 15:14:31
 Plant: TW01
 Report by UID: 8746109

Drawing No: 510852
 Revision: 1A

C NO PART NO DESCRIPTION QUANTITY REQUIRED LOCATION
 30001 30002

#	51085230001	CD-ROM ASSY ACY25 QSI-24X	REF	-	-	-	-
#	51085230002	CD-ROM ASSY ACY25 SAM-24X	-	REF	-	-	-
001	MAAA0015320	SCREW M2.0X0.4P+3FP-ZK(NL)	2	2			001
* 002	MABK17025B0	SCREW TPB2XM1.7+2.5K -BNI	1	-			002
003	ECCY2543100	ACY25_CDR_BRK	1	1			003
004	APCY2539100	ACY25 CDR PANEL ASSY QSI	1	-			004
005	APCY253B100	ACY25 CDR PANEL ASSY SAM	-	1			004
006	DD200003740	CDROM DRV 650M 5.25"W .5"H SN-124P	-	1			010
007	DD200005000	CDROM DRV 650M 5.25"W .5"H SCR-242	1	-			010

END OF REPORT

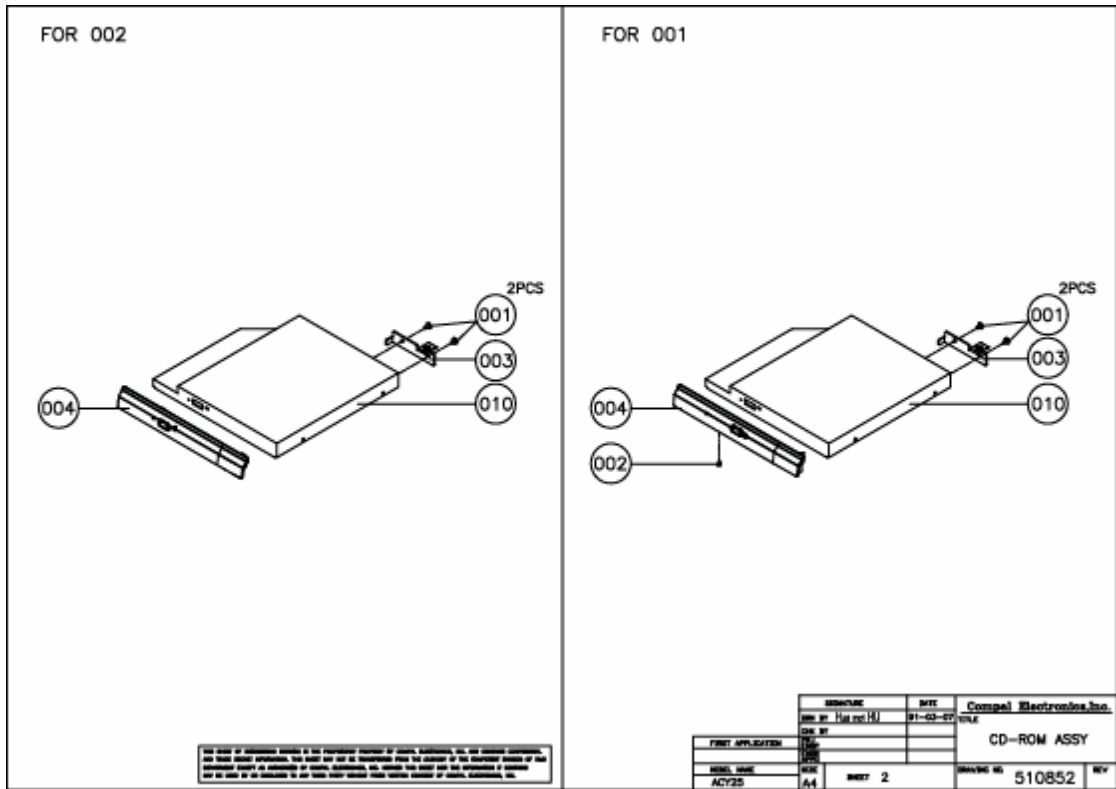

FOR 003

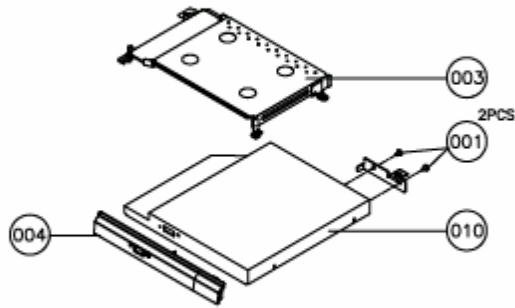

ALL DIMENSIONS UNLESS OTHERWISE SPECIFIED ARE IN MILLIMETERS. DIMENSIONS IN PARENTHESES ARE IN INCHES. DIMENSIONS IN PARENTHESES ARE NOT TO BE USED AS DIMENSIONS. DIMENSIONS IN PARENTHESES ARE NOT TO BE USED AS DIMENSIONS. DIMENSIONS IN PARENTHESES ARE NOT TO BE USED AS DIMENSIONS. DIMENSIONS IN PARENTHESES ARE NOT TO BE USED AS DIMENSIONS.

REVISION	DATE	Company Electronics, Inc.
REV BY: HJ (HJ)	91-03-08	DATE
DESIGN BY:		DVD ASSY
DATE:		
REV:		
REV: A4	SHEET 3	DRAWING NO. 510853 REV

Material List by Single-Item/Single-Level

Date : 05-02-2002
 Time : 15:15:02
 Plant: TW01
 Report by UID: 8746109

Drawing No: 510854
 Revision: 1A

C NO	PART NO	DESCRIPTION	QUANTITY REQUIRED				LOCATION
			30001	30002			
#	51085430001	CD-RW ASSY ACY25 KME-8X	REF	-	-	-	
#	51085430002	CD-RW ASSY ACY25 TOS-16X	-	REF	-	-	
001	MAAA0015320	SCREW M2.0X0.4P+3FP-ZK(NL)	2	2			001
002	MAAAA173500	SCREW TPB-1.7 3.5P-ZK	3	-			002
003	ECCY2543100	ACY25_CDR_BRK	1	1			003
004	APCY253K100	ACY25_CDRW_PANEL_ASSY_KME	1	-			004
* 005	APCY257W100	ACY25_CDRW_PANEL_ASSY_TSH	-	1			004
006	DD400000520	CD-RW DRV 650M 5.25"W .5"H UJDA340CP	1	-			010
007	DD400000900	CD-RW DRV 650M 5.25"W .5"H SR-C8102	-	1			010

END OF REPORT

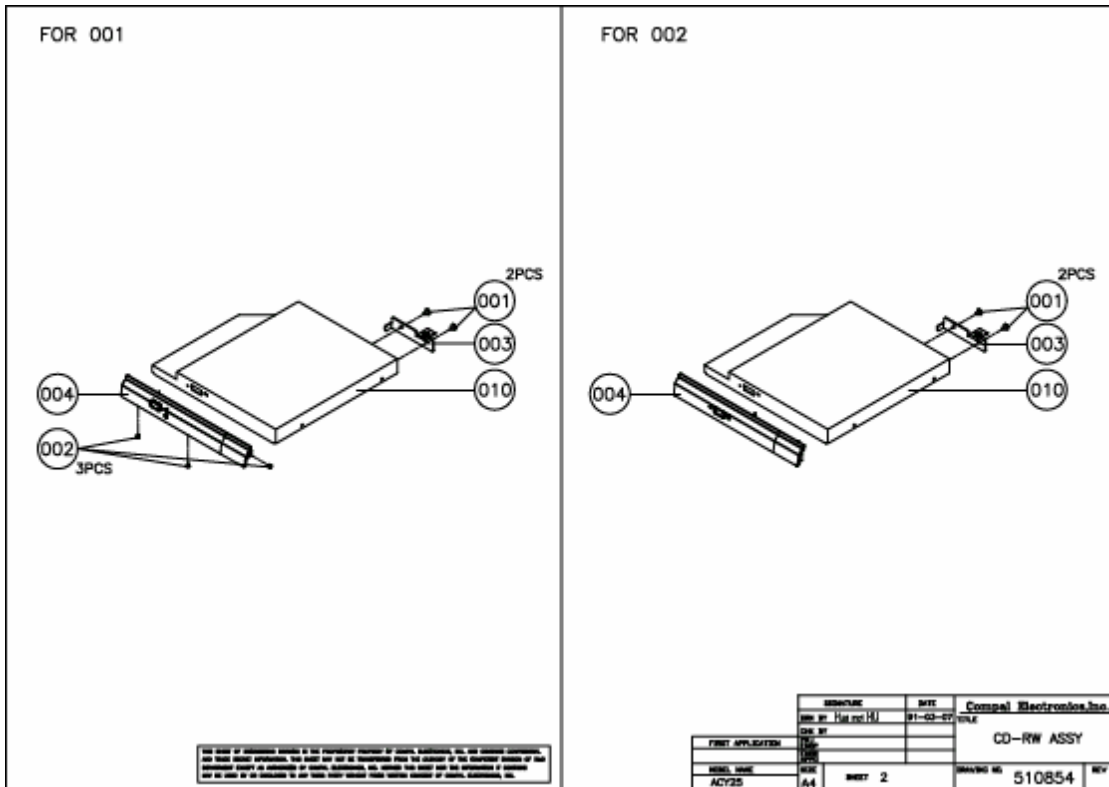

Material List by Single-Item/Single-Level

Date : 05-02-2002
 Time : 15:15:16
 Plant: TW01
 Report by UID: 8746109

Drawing No: 510855
 Revision: 1A

C NO	PART NO	DESCRIPTION	QUANTITY REQUIRED					LOCATION
			30001	30002	30003	30004	30005	
#	51085530001	COMBO ASSY ACY25 TOS-8X(SD-R2102)	REF	-	-	-	-	
#	51085530002	COMBO ASSY ACY25 KME-8X (UJDA720)	-	REF	-	-	-	
#	51085530003	COMBO ASSY ACY25 HLDS-8X(GCC-4080)	-	-	REF	-	-	
#	51085530004	COMBO ASSY ACY25 AVC (SD-R2102)	-	-	-	REF	-	
#	51085530005	COMBO ASSY ACY25-16X SHP(SD-R2212)	-	-	-	-	REF	
001	MAAA0015320	SCREW M2.0X0.4P+3FP-ZK(NL)	2	2	2	2	2	001
002	MAAAA173500	SCREW TPB-1.7 3.5P-ZK	-	3	-	-	-	002
003	ECCY2543100	ACY25_CDR_BRK	1	1	1	1	1	003
004	APCY253D100	ACY25 DRDRW PANEL ASSY TSH	1	-	-	1	1	004
005	APCY253N100	ACY25 DVDRW PANEL ASSY KME	-	1	-	-	-	004
006	APCY253Q100	ACY25 DVDRW PANEL ASSY HLDS	-	-	1	-	-	004
007	DD5000002C0	COMBO DRV 650/4.7 35"H SD-R2102 1016	1	-	-	-	-	010
008	DD5000002D0	COMBO DRV 650/4.7 35"H SD-R2102 AVC 1016	-	-	-	1	-	010
009	DD500000320	COMBO DRV 650/4.7 .5"H UJDA720CP	-	1	-	-	-	010
010	DD500000500	COMBO DRV 650/4.7 .5"H GCC-4080N	-	-	1	-	-	010
011	DD500000900	COMBO DRV 650/4.7 .5"H SD-R2212 SHARP	-	-	-	-	1	010

Material List by Single-Item/Single-Level

Date : 05-02-2002
 Time : 15:15:16
 Plant: TW01
 Report by UID: 8746109

Drawing No: 510855
 Revision: 1A

C NO PART NO DESCRIPTION QUANTITY REQUIRED LOCATION
 30006 30007 30008

51085530006 COMBO ASSY ACY25-16X MIT(SD-R2212) REF - - - -
 # 51085530007 COMBO ASSY ACY25-16X TOS(SD-R2212) - REF - - - -
 # 51085530008 COMBO ASSY ACY25-16X KME(UJDA730) - - REF - -

001 MAAA0015320 SCREW M2.0X0.4P+3FP-ZK(NL) 2 2 2 001
 002 MAAA173500 SCREW TPB-1.7 3.5P-ZK - - 3 002
 003 ECCY2543100 ACY25_CDR_BRK 1 1 1 003
 004 APCY253D100 ACY25 DRDRW PANEL ASSY TSH 1 1 - 004
 005 APCY253N100 ACY25 DVDRW PANEL ASSY KME - - 1 004
 006 DD500001000 COMBO DRV 650/4.7 .5"H SD-R2212 MIT 1 - - 010
 007 DD500001100 COMBO DRV 650/4.7 .5"H SD-R2212 TOS - 1 - 010
 008 DD500001200 COMBO DRV 650/4.7 .5"H UJDA730 KME - - 1 010

END OF REPORT

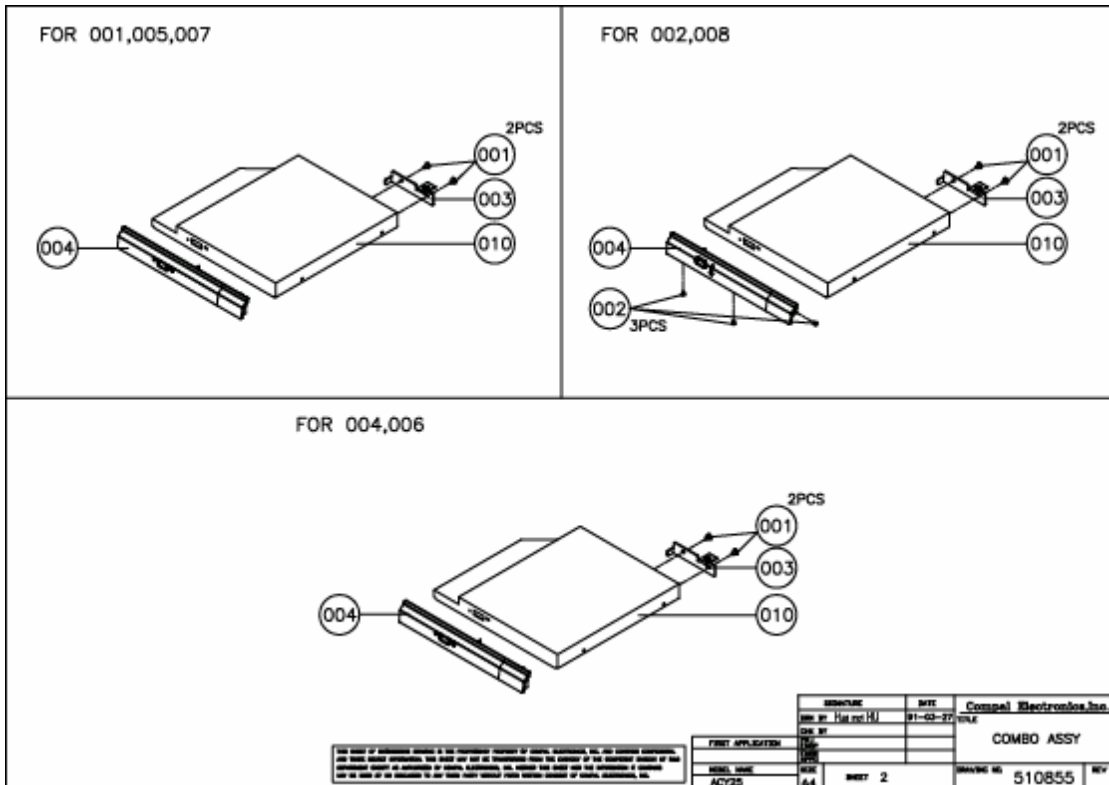

Material List by Single-Item/Single-Level

Date : 05-09-2002
 Time : 15:58:28
 Plant: TW01
 Report by UID: 8746109

Drawing No: 510856
 Revision: 1B

C NO	PART NO	DESCRIPTION	QUANTITY REQUIRED					LOCATION	
			30001	30002	30011	30012	30013		
#	51085630001	LCD ASSY ACY25 14.1"-AU	REF	-	-	-	-		
#	51085630002	LCD ASSY ACY25 14.1"-CPT	-	REF	-	-	-		
#	51085630011	LCD ASSY ACY25 15"-AU (XGA)	-	-	REF	-	-		
#	51085630012	LCD ASSY ACY25 15"-LG (XGA)	-	-	-	REF	-		
#	51085630013	LCD ASSY ACY25 15"-HIT (XGA)	-	-	-	-	REF		
001	AC600014000	LCD MODU TX38D85VC1CAB 15.0" (HITACHI)	-	-	-	-	1	001	
002	AC600019400	LCD MODU CLAA141XF01 14.1" (CPT)	-	1	-	-	-	001	
003	AC600019500	LCD MODU LP150X04 15.0" (LG)	-	-	-	1	-	001	
004	AC600019600	LCD MODU B150XN01 15.0" (AU)	-	-	1	-	-	001	
005	AC600024700	LCD MODU B141XN04 V2 14.1" (AU)	1	-	-	-	-	001	
006	DC025032900	H-CON SET ACY25 SW-LCD LG 15" XGA	-	-	-	1	-	002	
007	DC025033000	H-CON SET ACY25 SW-LCD AU 15" XGA	-	-	1	-	-	002	
008	DC025033100	H-CON SET ACY25 SW-LCD HIT 15" XGA	-	-	-	-	1	002	
009	DC025033200	H-CON SET ACY25 SW-LCD AU 14.1" XGA	1	-	-	-	-	002	
010	DC025033300	H-CON SET ACY25 SW-LCD CPT 14.1" XGA	-	1	-	-	-	002	
011	PK070012600	INVERTER COMMON T511056.00 AMBIT	1	02	1	02	1	02	003
			--	--	--	--	--	--	
012	PK070012700	INVERTER COMMON TWS-442-117 SUMIDA	1	02	1	02	1	02	003
			--	--	--	--	--	--	
013	APCY251F100	ACY25 141 LCD BEZEL ASSY	1	1	-	-	-	101	
014	APCY251R100	ACY25 150 LCD BEZEL ASSY	-	-	1	1	1	101	
015	AMCY251M100	ACY25 150 LCD COVER ASSY	-	-	1	1	1	102	
016	APCY251C100	ACY25 141 LCD COVER SUB ASSY	1	1	-	-	-	102	
017	AMCY2571100	ACY25 141 LCD HINGE BRK R ASSY	1	1	-	-	-	103	
018	AMCY257D100	ACY25 150 LCD BRK AU R ASSY	-	-	1	-	-	103	
019	AMCY257F100	ACY25_150_LCD_BRK_NIT_R_ASSY	-	-	-	-	1	103	
* 020	AMCY2597100	ACY25_150_LCD_BRK_LG_R_ASSY	-	-	-	1	-	103	
021	AMCY251H100	ACY25 141 HINGE BRK L ASSY	1	1	-	-	-	104	
022	ECCY2577100	ACY25 150 LCD BRK AU L	-	-	1	-	-	104	
023	ECCY2579100	ACY25 150 LCD BRK HIT L	-	-	-	-	1	104	
* 024	ECCY2596100	ACY25_150_LCD_BRK_LG_L	-	-	-	1	-	104	
025	ELCY258E100	ACY25 LCD SCREW PAD	2	2	2	2	2	107	
026	FHCY258F100	ACY25 14 LCD SCREW BUMPER	2	2	-	-	-	108	
027	MAAA2003201	SCREW M2X0.4+3FR-NI	-	-	4	4	4	110	
028	MAC925003Z0	SCREW M2.5_9_5.5*0.8_03_R00	1	1	1	1	1	111	
029	MAC925004Z0	SCREW M2.5_9_5.5*0.8_05_R00	4	4	-	-	-	112	
030	MACK20251N0	M2.0 K 4.2*0.8 2.5 R00	4	4	-	-	-	113	
* 031	MACK25070N0	SCREW M2.5_K_5.5*0.8_07_R00	2	2	-	-	-	114	
032	MAC925004Z0	SCREW M2.5_9_5.5*0.8_05_R00	-	-	2	2	2	115	
033	MACK20251N0	M2.0 K 4.2*0.8 2.5 R00	-	-	6	6	6	116	
* 034	MACK25070N0	SCREW M2.5_K_5.5*0.8_07_R00	-	-	4	4	4	117	
* 035	ELCY255R100	ACY25_LCD_PANEL_MYLAR	1	1	1	1	1	118	

Material List by Single-Item/Single-Level

Date : 05-09-2002
 Time : 15:58:28
 Plant: TW01
 Report by UID: 8746109

Drawing No: 510856
 Revision: 1B

C NO	PART NO	DESCRIPTION	QUANTITY REQUIRED			LOCATION
			30021	30022	30023	
#	51085630021	LCD ASSY ACY25 15"-CPT (SXGA)	REF	-	-	-
#	51085630022	LCD ASSY ACY25 15"-LG (SXGA)	-	REF	-	-
#	51085630023	LCD ASSY ACY25 15"-IBM (SXGA)	-	-	REF	-
001	AC600009350	LCD MODU ITSX95C SPWG 15.0" IBM CHINA	-	-	1	001
002	AC600018600	LCD MODU LP150E01-A2M2 15.0" (LG)	-	1	-	001
003	AC600020440	LCD MODU CLAA150PA01(V2) 15" NEW T-CON	1	-	-	001
004	DC025032800	H-CON SET ACY25 SW-LCD LG 15" SXGA+	1	1	1	002
005	PK070012600	INVERTER COMMON T51T056.00 AMBIT	1	02	1	02
			--	--	--	
006	PK070012700	INVERTER COMMON TWS-442-117 SUMIDA	1	02	1	02
			--	--	--	
007	APCY251R100	ACY25 150 LCD BEZEL ASSY	1	1	1	101
008	AMCY251M100	ACY25 150 LCD COVER ASSY	1	1	1	102
009	AMCY257E100	ACY25 150 LCD BRK CPT R ASSY	1	1	1	103
010	ECCY257B100	ACY25 150 LCD BRK CPT L	1	1	1	104
011	ELCY258E100	ACY25 LCD SCREW PAD	2	2	2	107
012	MAAA2003201	SCREW M2X0.4+3FR-NI	4	4	4	110
013	MAC925003Z0	SCREW M2.5_9_5.5*0.8_03_R00	1	1	1	111
014	MAC925004Z0	SCREW M2.5_9_5.5*0.8_05_R00	2	2	2	115
015	MACK20251N0	M2.0 K 4.2*0.8 2.5 R00	6	6	6	116
* 016	MACK25070N0	SCREW M2.5_K_5.5*0.8_07_R00	4	4	4	117
* 017	ELCY255R100	ACY25_LCD_PANEL_MYLAR	1	1	1	118

END OF REPORT

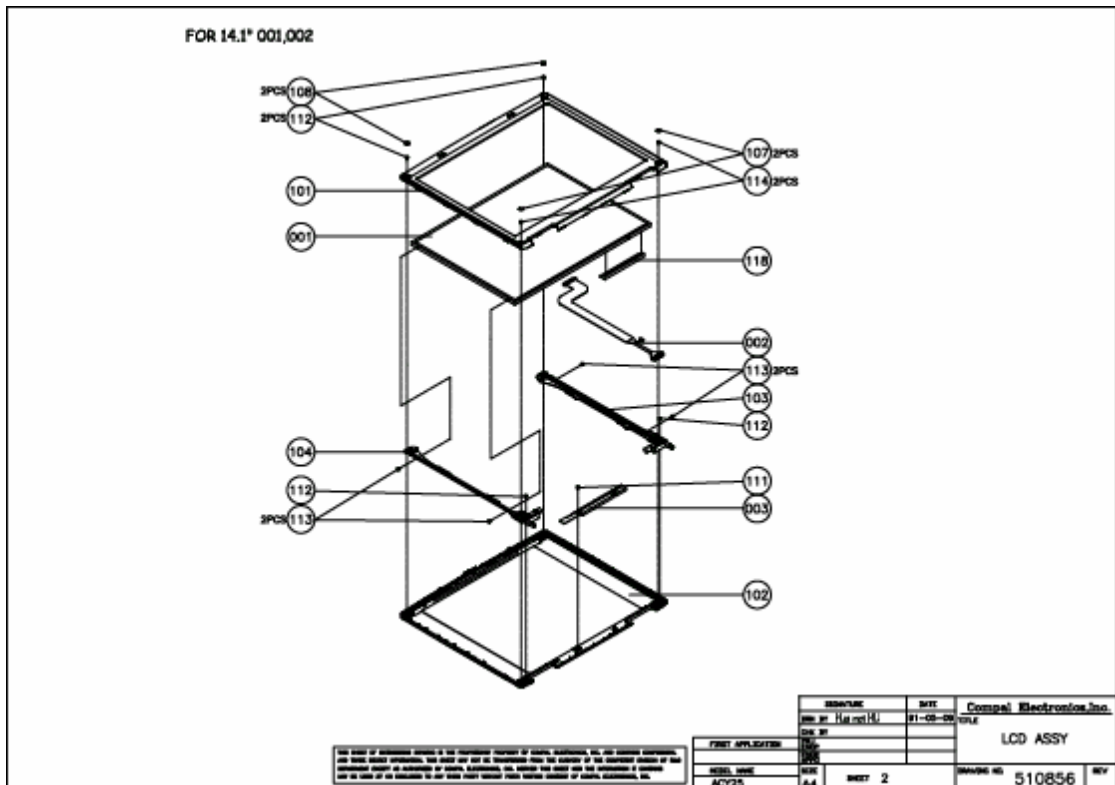

FOR 15" 011,012,013,021,022,023

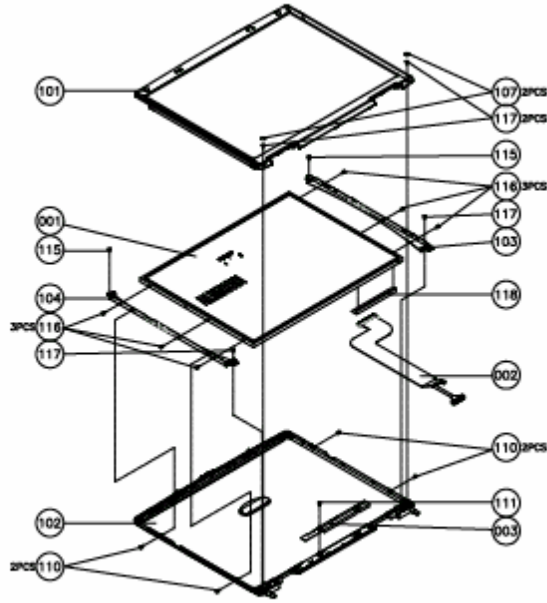

THE NAME OF APPLICATOR SHOWN IN THIS DOCUMENT IS SUBJECT OF TRADE, REGISTRATION, OR PATENT RIGHTS RESERVED. ALL OTHER TRADE NAMES, TRADE MARKS AND/OR PATENT RIGHTS ARE THE PROPERTY OF THE APPLICATOR. THE APPLICATOR IS NOT RESPONSIBLE FOR THE CONTENTS OF THIS DOCUMENT. THE APPLICATOR IS NOT RESPONSIBLE FOR THE CONTENTS OF THIS DOCUMENT. THE APPLICATOR IS NOT RESPONSIBLE FOR THE CONTENTS OF THIS DOCUMENT.

REV. NO.	DATE	COMPANY
01	01-08-00	Compal Electronics, Inc.
02		
03		
04		
05		
06		
07		
08		
09		
10		
11		
12		
13		
14		
15		
16		
17		
18		
19		
20		
21		
22		
23		
24		
25		
26		
27		
28		
29		
30		
31		
32		
33		
34		
35		
36		
37		
38		
39		
40		
41		
42		
43		
44		
45		
46		
47		
48		
49		
50		
51		
52		
53		
54		
55		
56		
57		
58		
59		
60		
61		
62		
63		
64		
65		
66		
67		
68		
69		
70		
71		
72		
73		
74		
75		
76		
77		
78		
79		
80		
81		
82		
83		
84		
85		
86		
87		
88		
89		
90		
91		
92		
93		
94		
95		
96		
97		
98		
99		
100		
101		
102		
103		
104		
105		
106		
107		
108		
109		
110		
111		
112		
113		
114		
115		
116		
117		
118		
119		
120		
121		
122		
123		
124		
125		
126		
127		
128		
129		
130		
131		
132		
133		
134		
135		
136		
137		
138		
139		
140		
141		
142		
143		
144		
145		
146		
147		
148		
149		
150		
151		
152		
153		
154		
155		
156		
157		
158		
159		
160		
161		
162		
163		
164		
165		
166		
167		
168		
169		
170		
171		
172		
173		
174		
175		
176		
177		
178		
179		
180		
181		
182		
183		
184		
185		
186		
187		
188		
189		
190		
191		
192		
193		
194		
195		
196		
197		
198		
199		
200		
201		
202		
203		
204		
205		
206		
207		
208		
209		
210		
211		
212		
213		
214		
215		
216		
217		
218		
219		
220		
221		
222		
223		
224		
225		
226		
227		
228		
229		
230		
231		
232		
233		
234		
235		
236		
237		
238		
239		
240		
241		
242		
243		
244		
245		
246		
247		
248		
249		
250		
251		
252		
253		
254		
255		
256		
257		
258		
259		
260		
261		
262		
263		
264		
265		
266		
267		
268		
269		
270		
271		
272		
273		
274		
275		
276		
277		
278		
279		
280		
281		
282		
283		
284		
285		
286		
287		
288		
289		
290		
291		
292		
293		
294		
295		
296		
297		
298		
299		
300		
301		
302		
303		
304		
305		
306		
307		
308		
309		
310		
311		
312		
313		
314		
315		
316		
317		
318		
319		
320		
321		
322		
323		
324		
325		
326		
327		
328		
329		
330		
331		
332		
333		
334		
335		
336		
337		
338		
339		
340		
341		
342		
343		
344		
345		
346		
347		
348		
349		
350		
351		
352		
353		
354		
355		
356		
357		
358		
359		
360		
361		
362		
363		
364		
365		
366		
367		
368		
369		
370		
371		
372		
373		
374		
375		
376		
377		
378		
379		
380		
381		
382		
383		
384		
385		
386		
387		
388		
389		
390		
391		
392		
393		
394		
395		
396		
397		
398		
399		
400		
401		
402		
403		
404		
405		
406		
407		
408		
409		
410		
411		
412		
413		
414		
415		
416		
417		
418		
419		
420		
421		
422		
423		
424		
425		
426		
427		
428		
429		
430		
431		
432		
433		
434		
435		
436		
437		
438		
439		
440		
441		
442		
443		
444		
445		
446		
447		
448		
449		
450		
451		
452		
453		
454		
455		
456		
457		
458		
459		
460		
461		
462		
463		
464		
465		
466		

Material List by Single-Item/Single-Level

Date : 05-02-2002
 Time : 15:16:09
 Plant: TW01
 Report by UID: 8746109

Drawing No: 510857
 Revision: 1A

C NO	PART NO	DESCRIPTION	QUANTITY REQUIRED		LOCATION
			30001	30002	
#	51085730001	LOGIC UPPER ASSY ACY25 W/WLAN	REF	- - - -	
#	51085730002	LOGIC UPPER ASSY ACY25 W/O WLAN	-	REF - - -	
001	DC330002700	ANTENNA 2.45G 190MM LEFT CNOAACY2501	1	-	001
002	DC330002710	ANTENNA 2.45G 415MM RIGHT CNOAACY2502	1	-	002
003	NBX08000300	FFC 8P F P1.0 PAD=0.7 40MM	1	1	003
004	NBX08000400	FFC 8P F P1.0 PAD=0.7 166MM	1	1	004
005	NBX30000700	FFC 30P F P1.0 PAD=0.7 142MM	1	1	005
006	PK230003300	SPK PACK ACY25 1W 80HM L	1	1	007
007	PK230003400	SPK PACK ACY25 1W 80HM R	1	1	008
008	DC025033500	H-CON SET ACY25 MODEN-MINI PCI-30 2P	1	1	009
009	AMCY2517100	ACY25 UP ESD PLATE SUB ASSY	1	1	101
010	AMCY2522100	ACY25 HINGE SADDLE R ASSY	1	1	102
011	AMCY2524100	ACY25 HINGE SADDLE L ASSY	1	1	103
012	AMCY2526100	ACY25 TRACK PAD BRACKET ASSY	1	1	104
013	AMCY253X100	ACY25 AUDIO ESD PLATE ASSY	1	1	105
014	APCY2515100	ACY25 LOG UP SUB ASSY	1	1	106
015	PK090004300	TRACK PAD ALPS KGDET008A	1	1	107
016	MAC00001206	SCREW M2.5X0.45+4FP-NI (NL)	4	4	110
017	MAC925003Z0	SCREW M2.5_9_5.5*0.8_03_R00	17	-	111
018	MAC925003Z0	SCREW M2.5_9_5.5*0.8_03_R00	-	13	112
* 019	43556930001	SMT ASSY AU/TP BD LS-1341 ACY25	1	1	251
* 020	43557030001	SMT ASSY PHONE BD LS-1342 ACY25	1	1	252

END OF REPORT

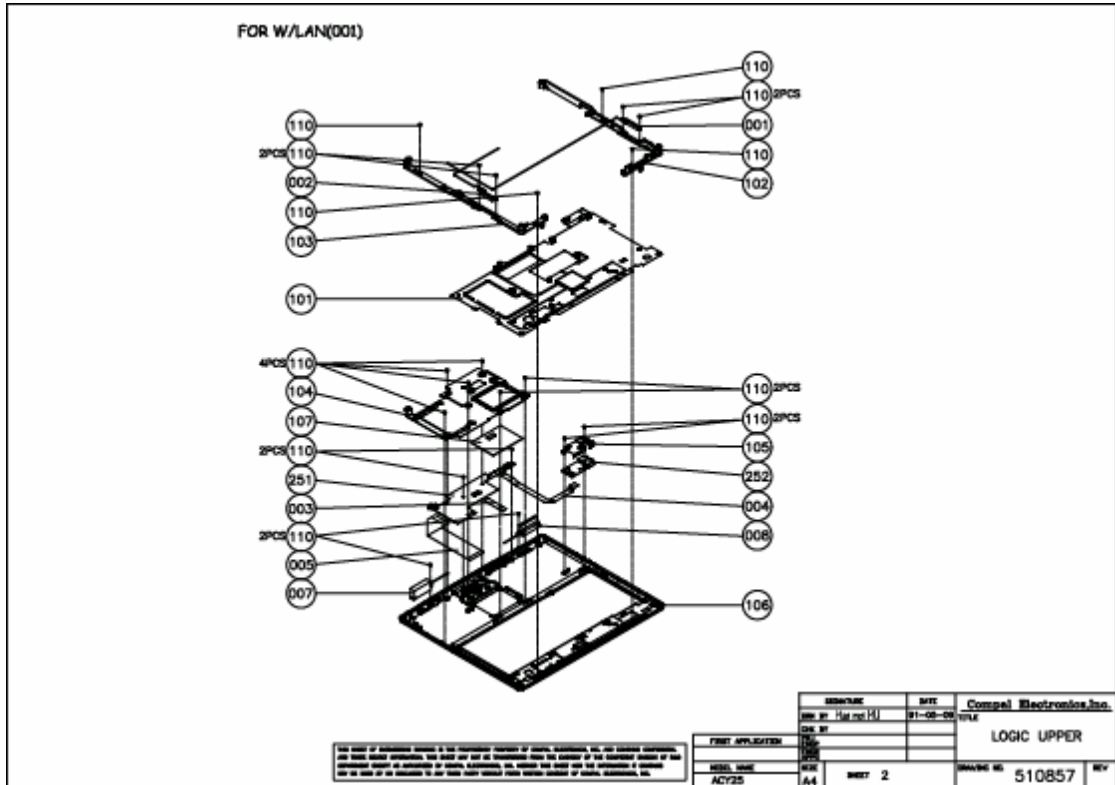

Material List by Single-Item/Single-Level

Date : 05-02-2002
 Time : 16:39:07
 Plant: TW01
 Report by UID: 8746109

Drawing No: 54B601
 Revision: 1A

C NO	PART NO	DESCRIPTION	QUANTITY REQUIRED				LOCATION
			30001	30002			
#	54B60130001	SYS UNIT ACY25-030 W/WLAN	REF	-	-	-	-
#	54B60130002	SYS UNIT ACY25-030 W/O WLAN	-	REF	-	-	-
001	PK010005700	F/D MODEM ACT10 1456VQL9Q(INT)	-	1			007
002	PK293000200	W/M CARD ACT10 WLL030M ASKEY	1	-			008
003	46121030001	CPCBA,M/B LA-1341 ACY25	1	1			251
004	45557130001	PCBA SW BD LS-1343 ACY25	1	1			252
005	51085730001	LOGIC UPPER ASSY ACY25 W/WLAN	1	-			253
006	51085730002	LOGIC UPPER ASSY ACY25 W/O WLAN	-	1			253
007	X6621330001	MEC PARTS ACY25	1	1			300

END OF REPORT

THIS SHEET OF DIMENSIONAL DRAWING IS THE PROPRIETARY PROPERTY OF DORVAL ELECTRONICS, INC. AND CONTAINS CONFIDENTIAL AND TRADE SECRET INFORMATION. THIS SHEET MAY NOT BE TRANSMITTED FROM THE CONTROL OF THE COMPANY OR UNDER OF R&D EQUIPMENT EXCEPT AS AUTHORIZED BY DORVAL ELECTRONICS, INC. NEITHER THIS SHEET NOR THE INFORMATION IT CONTAINS MAY BE USED BY OR DISCLOSED TO ANY THIRD PARTY WITHOUT PRIOR WRITTEN CONSENT OF DORVAL ELECTRONICS, INC.

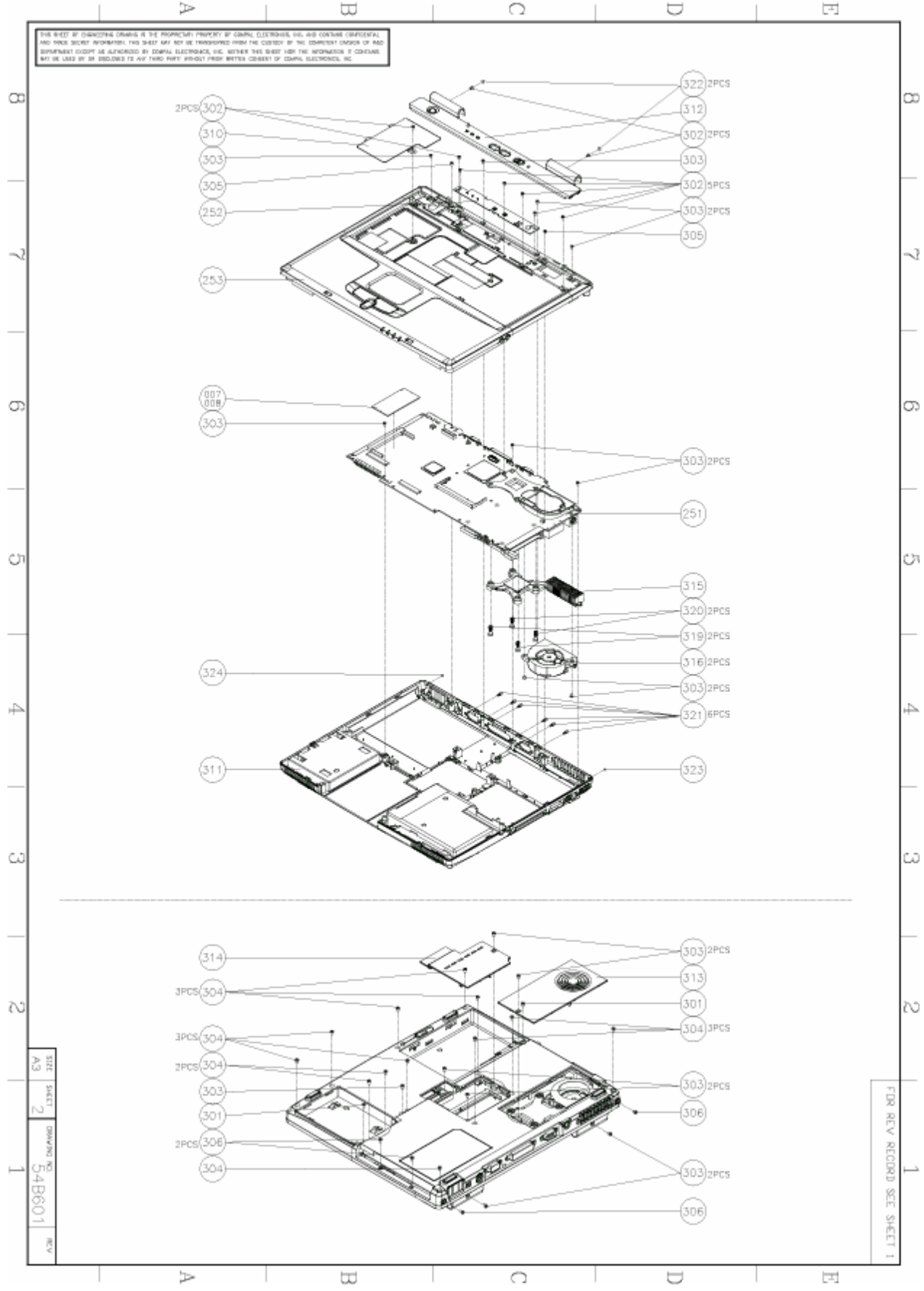

Table of contents:

1. System Description	1-1
<i>Scope</i>	1-2
<i>Electric Specifications</i>	1-4
2. Software Specification for System BIOS	2-1
<i>System Component Summary</i>	2-1
<i>Setup screens</i>	2-14
3. Hardware	3-1
<i>Major Sub-assembly Specification</i>	3-1
4. Power Supply	4-1
<i>DC-DC Converter</i>	4-3
<i>DC-DC Output</i>	4-4
<i>ACY23 14.1,15" Inverter Specification</i>	4-7
5. Disassembly	5-1
<i>General</i>	5-1
<i>Remove Battery Module</i>	5-7
<i>Remove PC Card Module</i>	5-8
<i>Remove Display Assembly</i>	5-9
<i>Remove Keyboard / button board</i>	5-17
<i>Remove Wireless LAN / Modem Unit</i>	5-19
<i>Remove Expansion Memory</i>	5-22
<i>Remove CD-RW/DVD-ROM or CD-ROM/Combo Drive</i>	5-25
<i>Remove FDD Drive</i>	5-27
<i>Remove HDD Drive</i>	5-29
<i>Remove FAN</i>	5-30

<i>Remove CPU</i>	5-31
<i>Remove Top Cover</i>	5-33
<i>Remove Touch Pad</i>	5-35
<i>Remove Speakers</i>	5-37
<i>Remove Microphone jack</i>	5-38
<i>Remove System board</i>	5-39
6. Testing and Troubleshooting	6-1
A. Spare Parts	A-1