

SERVICE MANUAL

TN120R

notebook



Notebook Computer

TN120R

Service Manual

Notice

The company reserves the right to revise this publication or to change its contents without notice. Information contained herein is for reference only and does not constitute a commitment on the part of the manufacturer or any subsequent vendor. They assume no responsibility or liability for any errors or inaccuracies that may appear in this publication nor are they in anyway responsible for any loss or damage resulting from the use (or misuse) of this publication.

This publication and any accompanying software may not, in whole or in part, be reproduced, translated, transmitted or reduced to any machine readable form without prior consent from the vendor, manufacturer or creators of this publication, except for copies kept by the user for backup purposes.

Brand and product names mentioned in this publication may or may not be copyrights and/or registered trademarks of their respective companies. They are mentioned for identification purposes only and are not intended as an endorsement of that product or its manufacturer.

Version 1.0
January 2008

Trademarks

Intel, **Celeron** and **Intel Core** are trademarks/registered trademarks of Intel Corporation.

Windows® is a registered trademark of Microsoft Corporation.

Other brand and product names are trademarks and./or registered trademarks of their respective companies.

About this Manual

This manual is intended for service personnel who have completed sufficient training to undertake the maintenance and inspection of personal computers.

It is organized to allow you to look up basic information for servicing and/or upgrading components of the *TN120R* series notebook PC.

The following information is included:

Chapter 1, Introduction, provides general information about the location of system elements and their specifications.

Chapter 2, Disassembly, provides step-by-step instructions for disassembling parts and subsystems and how to upgrade elements of the system.

Appendix A, Part Lists

Appendix B, Schematic Diagrams

IMPORTANT SAFETY INSTRUCTIONS

Follow basic safety precautions, including those listed below, to reduce the risk of fire, electric shock and injury to persons when using any electrical equipment:

1. Do not use this product near water, for example near a bath tub, wash bowl, kitchen sink or laundry tub, in a wet basement or near a swimming pool.
2. Avoid using a telephone (other than a cordless type) during an electrical storm. There may be a remote risk of electrical shock from lightning.
3. Do not use the telephone to report a gas leak in the vicinity of the leak.
4. Use only the power cord and batteries indicated in this manual. Do not dispose of batteries in a fire. They may explode. Check with local codes for possible special disposal instructions.
5. This product is intended to be supplied by a Listed Power Unit (DC Output 19V, 3.42A or 18.5V, 3.5A **(65W)** AC/DC Adapter).

CAUTION

Always disconnect all telephone lines from the wall outlet before servicing or disassembling this equipment.

**TO REDUCE THE RISK OF FIRE, USE ONLY NO. 26 AWG OR LARGER,
TELECOMMUNICATION LINE CORD**

This Computer's Optical Device is a Laser Class 1 Product

Instructions for Care and Operation

The notebook computer is quite rugged, but it can be damaged. To prevent this, follow these suggestions:

1. **Don't drop it, or expose it to shock.** If the computer falls, the case and the components could be damaged.



2. **Keep it dry, and don't overheat it.** Keep the computer and power supply away from any kind of heating element. This is an electrical appliance. If water or any other liquid gets into it, the computer could be badly damaged.

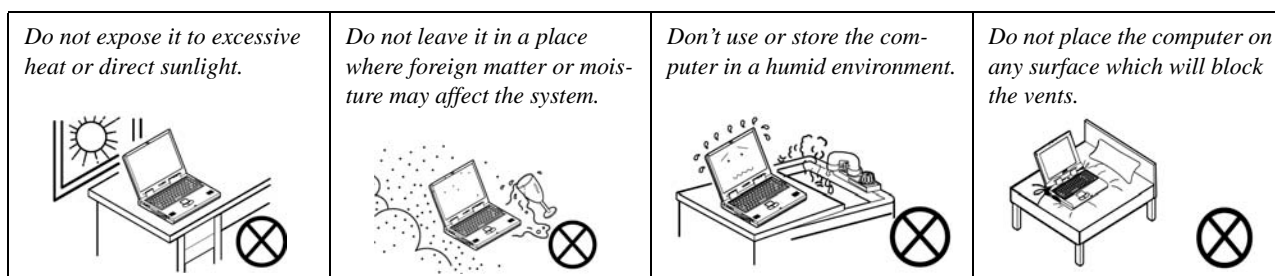

3. **Follow the proper working procedures for the computer.** Shut the computer down properly and don't forget to save your work. Remember to periodically save your data as data may be lost if the battery is depleted.

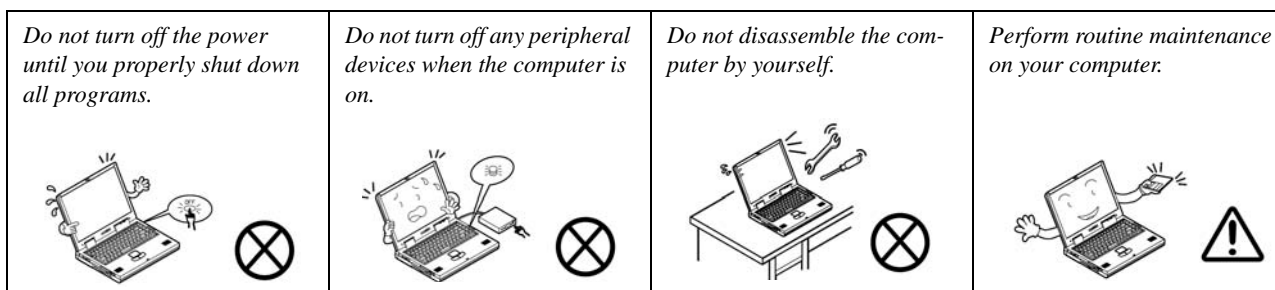

Preface

4. **Avoid interference.** Keep the computer away from high capacity transformers, electric motors, and other strong magnetic fields. These can hinder proper performance and damage your data.
5. **Take care when using peripheral devices.**

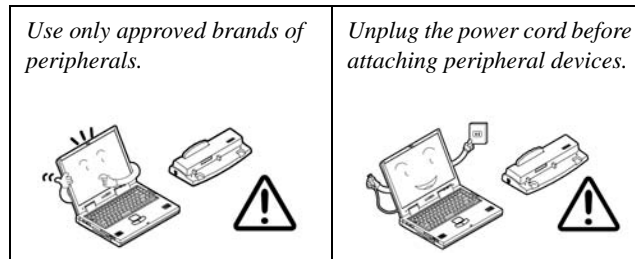

Power Safety

The computer has specific power requirements:

- Only use a power adapter approved for use with this computer.
- Your AC adapter may be designed for international travel but it still requires a steady, uninterrupted power supply. If you are unsure of your local power specifications, consult your service representative or local power company.
- The power adapter may have either a 2-prong or a 3-prong grounded plug. The third prong is an important safety feature; do not defeat its purpose. If you do not have access to a compatible outlet, have a qualified electrician install one.
- When you want to unplug the power cord, be sure to disconnect it by the plug head, not by its wire.
- Make sure the socket and any extension cord(s) you use can support the total current load of all the connected devices.
- Before cleaning the computer, make sure it is disconnected from any external power supplies.

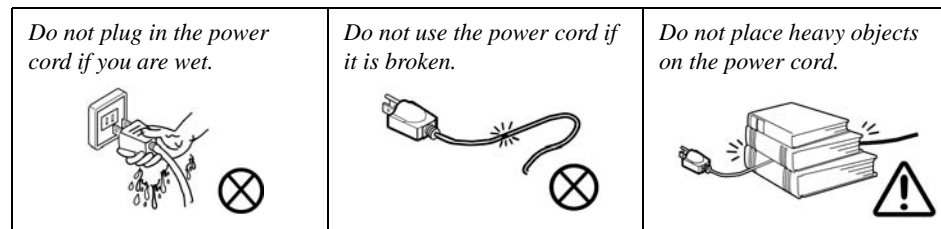

Power Safety Warning

Before you undertake any upgrade procedures, make sure that you have turned off the power, and disconnected all peripherals and cables (including telephone lines). It is advisable to also remove your battery in order to prevent accidentally turning the machine on.

Battery Precautions

- Only use batteries designed for this computer. The wrong battery type may explode, leak or damage the computer.
- Do not continue to use a battery that has been dropped, or that appears damaged (e.g. bent or twisted) in any way. Even if the computer continues to work with a damaged battery in place, it may cause circuit damage, which may possibly result in fire.
- Recharge the batteries using the notebook's system. Incorrect recharging may make the battery explode.
- Do not try to repair a battery pack. Refer any battery pack repair or replacement to your service representative or qualified service personnel.
- Keep children away from, and promptly dispose of a damaged battery. Always dispose of batteries carefully. Batteries may explode or leak if exposed to fire, or improperly handled or discarded.
- Keep the battery away from metal appliances.
- Affix tape to the battery contacts before disposing of the battery.
- Do not touch the battery contacts with your hands or metal objects.



Battery Disposal

The product that you have purchased contains a rechargeable battery. The battery is recyclable. At the end of its useful life, under various state and local laws, it may be illegal to dispose of this battery into the municipal waste stream. Check with your local solid waste officials for details in your area for recycling options or proper disposal.

Caution

Danger of explosion if battery is incorrectly replaced. Replace only with the same or equivalent type recommended by the manufacturer. Discard used battery according to the manufacturer's instructions.

Related Documents

You may also need to consult the following manual for additional information:

User's Manual on CD

This describes the notebook PC's features and the procedures for operating the computer and its ROM-based setup program. It also describes the installation and operation of the utility programs provided with the notebook PC.

Contents

Introduction1-1

Overview	1-1
System Specifications	1-2
External Locator - Top View with LCD Panel Open	1-5
External Locator - Front & Rear Views	1-6
External Locator - Right & Left Side Views	1-7
External Locator - Bottom View	1-8
Mainboard Overview - Top (Key Parts)	1-9
Mainboard Overview - Bottom (Key Parts)	1-10
Mainboard Overview - Top (Connectors)	1-11
Mainboard Overview - Bottom (Connectors)	1-12

Disassembly2-1

Overview	2-1
Maintenance Tools	2-2
Connections	2-2
Maintenance Precautions	2-3
Removing the Battery	2-5
Removing the Hard Disk Drive	2-6
Removing the Modem Module	2-8
Removing the System Memory (RAM)	2-9
Removing the Processor	2-11
Removing the Wireless LAN Module	2-14
Removing the Bluetooth Module	2-15
Removing the Optical (CD/DVD) Device	2-16
Removing the Keyboard	2-17

Part ListsA-1

Part List Illustration Location	A-2
Top (TN120R)	A-3
Bottom (TN120R)	A-4

LCD (TN120R)	A-5
Combo (TN120R)	A-6
DVD-DUAL-RW (TN120R)	A-7
HDD (TN120R)	A-8

Schematic Diagrams.....B-1

SYSTEM BLOCK DIAGRAM	B-2
Merom CPU-1	B-3
Merom CPU-2	B-4
GM965 Crestline 1/5	B-5
GM965 Crestline 2/5, DRAM	B-6
GM965 Crestline 3/5	B-7
GM965 Crestline 4/5	B-8
GM965 Crestline 5/5	B-9
DDRII SO-DIMM 0	B-10
DDRII SO- DIMM 1	B-11
PANEL, INVERTER, CRT, FTP	B-12
ICH8-M 1/4, SATA	B-13
ICH8-M 2/4, PCI, USB	B-14
ICH8-M 3/4	B-15
ICH8-M 4/4	B-16
CLOCK GENERATOR	B-17
NEW CARD, MINI PCIE	B-18
IEEE 1394 VT6311S	B-19
ENE MR510, 7 IN 1	B-20
AUDIO CODEC ALC883	B-21
AUDIO AMP2056A	B-22
KBC-ITE IT8512E	B-23
ODD, CCD, BT, Multi I/O	B-24
LED, FAN, CLICK, LID	B-25
3VS, 5VS, POWER S/W	B-26

Preface

POWER GPU/1.25VS	B-27
POWER 3.3V/5V	B-28
POWER 1.5VS/1.05VS	B-29
POWER 1.8V/0.9V	B-30
CHARGER	B-31
VCORE FOR MEROM CPU	B-32
Multi Board, PCIE LAN RTL8111B	B-33
Multi Board, LED, USB	B-34
Multi Board, 3G, MDC, RJ11, LID	B-35
FPT ExBoard FINGERPRINT	B-36
FPT MBoard FINGERPRINT	B-37
FPT MBoard TP, KEY, CIR	B-38
CLICK BOARD	B-39

Chapter 1: Introduction

Overview

This manual covers the information you need to service or upgrade the **TN120R** series notebook computer. Information about operating the computer (e.g. getting started, and the *Setup* utility) is in the *User's Manual*. Information about drivers (e.g. VGA & audio) is also found in *User's Manual*. That manual is shipped with the computer.

Operating systems (e.g. *Windows XP*, *Windows Vista*, etc.) have their own manuals as do application software (e.g. word processing and database programs). If you have questions about those programs, you should consult those manuals.

The **TN120R** series notebook is designed to be upgradeable. See **“Disassembly” on page 2 - 1** for a detailed description of the upgrade procedures for each specific component. Please note the warning and safety information indicated by the “” symbol.

The balance of this chapter reviews the computer's technical specifications and features.

System Specifications



Latest Specification Information

The specifications listed in this Appendix are correct at the time of going to press. Certain items (particularly processor types/speeds and CD/DVD device types) may be changed, delayed or updated due to the manufacturer's release schedule. Check with your service center for details.

Feature	Specification	
Processor	Intel® Core™2 Duo Processor (478-pin) Micro-FC-PGA Package, Socket P T8100/ T8300	45nm (45 Nanometer) Process Technology 3MB On-die L2 Cache & 800MHz FSB 2.1/ 2.4 GHz
	Intel® Core™2 Duo Processor (478-pin) Micro-FC-PGA Package, Socket P T9300/ T9500	45nm (45 Nanometer) Process Technology 6MB On-die L2 Cache & 800MHz FSB 2.5/ 2.6 GHz
	Intel® Core™2 Duo Processor (478-pin) Micro-FC-PGA Package, Socket P T7100/ T7250	65nm (65 Nanometer) Process Technology 2MB On-die L2 Cache & 800MHz FSB 1.8/ 2.0 GHz
	Intel® Core™2 Duo Processor (478-pin) Micro-FC-PGA Package, Socket P T7300/ T7500/ T7700/ T7800	65nm (65 Nanometer) Process Technology 4MB On-die L2 Cache & 800MHz FSB 2.0/ 2.2/ 2.4/ 2.6 GHz
	Intel® Celeron® M Processor (478-pin) Micro-FCPGA Package, Socket P 530/ 540/ 550/ 560	65nm (65 Nanometer) Process Technology 1MB On-die L2 Cache & 533MHz FSB 1.73/ 1.86/ 2.0/ 2.3 GHz
Core Logic	Intel® GM965 + ICH8M Chipset	
LCD	12.1" WXGA (1280 * 800) TFT LCD Touch Panel	
BIOS	One 8Mb SPI Flash ROM	Phoenix™ BIOS

Feature	Specification	
Memory	Two 200 Pin SO-DIMM Sockets Supporting DDRII (DDR2) 667 MHz Memory Expandable up to 4GB (512/ 1024/ 2048 MB DDRII Modules)	
	512MB Or 1GB Intel® Turbo Memory Module (Option)	
Security	Security (Kensington® Type) Lock Slot	BIOS Password
	Fingerprint ID Reader Module (Factory Option)	
Storage	One Changeable 12.7mm(h) Optical Device (CD/DVD) Type Drive (see " Optional " on page 4) Easy Changeable 2.5" 9.5 mm (h) SATA (Serial) HDD	
Video Adapter	Intel GM965 Integrated Video Shared Memory Architecture - Supports up to 256MB of Video Memory (dynamically allocated from system memory where needed) Supports DirectX9.0 3D Graphics Engine Accelerator Supports DualView™	
Audio	Integrated Azalia Compliant Interface	2 * Built-In Speakers
	3D Stereo Enhanced Sound System Sound-Blaster PRO™ Compatible	Built-In Microphone
Keyboard & Pointing Device	Winkey Keyboard	Built-In TouchPad with Scrolling Function
	Stylus Pen for Touch Panel	
Card Reader	Embedded 7-in-1 Card Reader (MS/ MS Pro/ SD/ Mini SD/ MMC/ RS MMC/ MS Duo) Note: MS Duo/ Mini SD/ RS MMC Cards require a PC adapter	
Card Slots	One ExpressCard/34(54) Slot	
Interface	Three USB 2.0 Ports	One RJ-45 LAN Jack
	One Headphone-Out Jack	One DC-in Jack
	One Microphone-In Jack	One External Monitor Port
	One S/PDIF Out Jack	One Mini-IEEE 1394 Port
	One RJ-11 Modem Jack	2 Built-In Instant Keys (Menu, Rotation)
Power Management	Supports ACPI 3.0	Supports Wake on USB
	Supports Wake on LAN	Supports Resume from Modem Ring
Power	Full Range AC/DC Adapter AC input 100 - 240V, 50 - 60Hz, DC Output 19V, 3.42A / 18.5V, 3.5A (65 Watts)	
Battery	4 Cell Smart Lithium-Ion Battery Pack, 14.8V/2.4AH 8 Cell Smart Lithium-Ion Battery Pack, 14.8V/4.4AH (Option)	

Introduction

Feature	Specification	
<p>Communication</p> <p>*Note: The Intel Turbo Memory and 3.5G Modules cannot coexist. If one of these factory options is included in your purchase option, then the other is unavailable.</p>	<p>1000/100/ 10 Mb Fast Ethernet LAN Azalia 56K Plug and Play Fax Modem V.90 & V.92 Compliant</p> <p>Wireless LAN Module Options: 802.11 b/g MiniCard USB Wireless LAN Module (Option) Intel PRO/Wireless 3945ABG MiniCard PCIe Wireless LAN Module (Option) Intel PRO/Wireless 4965AGN MiniCard PCIe Wireless LAN Module (Option)</p> <p>1.3M or 2.0M Pixel USB PC Camera Module (Factory Option)</p> <p>Bluetooth 2.0 + EDR (Enhanced Data Rate) Module (Factory Option)</p> <p>*UMTS/HSPDA-based 3.5G Module with MiniCard Interface (Factory Option) Quad-band GSM/GPRS (850 MHz, 900 MHz, 1800 MHz, 1900 MHz) UMTS WCDMA FDD (2100 MHz)</p>	
<p>Environmental Spec</p>	<p>Temperature</p> <p>Operating: 5°C ~ 35°C Non-Operating: -20°C ~ 60°C</p>	<p>Relative Humidity</p> <p>Operating: 20% ~ 80% Non-Operating: 10% ~ 90%</p>
<p>Dimensions & Weight</p>	<p>306mm (w) * 224mm (d) * 35 - 37.5mm (h) 2.1 kg With 4 Cell Battery and ODD</p>	
<p>Optional</p> <p>*Note: The Intel Turbo Memory and 3.5G Modules cannot coexist. If one of these factory options is included in your purchase option, then the other is unavailable.</p>	<p>Optical Drive Module Options: DVD/CD-RW Combo Drive Module Super Multi Drive Module</p> <p>Wireless LAN Module Options: 802.11 b/g MiniCard USB Wireless LAN Module Intel PRO/Wireless 3945ABG MiniCard PCIe Wireless LAN Module Intel PRO/Wireless 4965AGN MiniCard PCIe Wireless LAN Module</p> <p>8 Cell Smart Lithium-Ion Battery Pack</p>	<p>Bluetooth 2.0 + EDR (Enhanced Data Rate) Module (Factory Option)</p> <p>1.3M or 2.0M Pixel USB PC Camera Module (Factory Option)</p> <p>Fingerprint ID Reader Module (Factory Option)</p> <p>*512MB Or 1GB Intel® Turbo Memory Module(Robson) NAND Flash Memory Card Module (Factory Option) or *UMTS/HSPDA-based 3.5G Module with MiniCard Interface (Factory Option)</p>



UMTS Modes

Note that UMTS modes CAN NOT be used in North America.

External Locator - Top View with LCD Panel Open



Figure 1
Top View with LCD
Panel Open

1. Built-In PC Camera
(Optional)
2. LCD
3. Fingerprint Reader Module
(Optional)
4. Menu & Screen Rotation Buttons
5. Speakers
6. Screen Hinge
7. LED Status Indicators
8. Keyboard
9. Touchpad & Buttons
10. LED Power & Communication Indicators
11. Power Switch
12. Built-In Microphone

Introduction

Figure 2
Front View

1. LED Power & Communication Indicators
2. Power Switch
3. S/PDIF-Out Jack
4. Microphone-In Jack
5. Headphone-Out Jack
6. 7-in-1 Card Reader
7. Stylus Pen Holder

External Locator - Front & Rear Views



Figure 3
Rear View

1. Security Lock Slot
2. 2 * USB 2.0 Ports
3. DC-In Jack
4. Battery



External Locator - Right & Left Side Views



Figure 4
Right Side View

1. Stylus Pen Holder
2. Optical Device (for DVD Device)
3. Emergency Eject Hole
4. 1 * USB 2.0 Port
5. RJ-11 Phone Jack
6. RJ-45 LAN Jack



Figure 5
Left Side View

1. External Monitor Port
2. Mini-IEEE 1394 Port (supports **SELF Powered** IEEE 1394 devices only)
3. Vent
4. ExpressCard/54(34) Slot

External Locator - Bottom View

Figure 6
Bottom View

1. Battery
2. Hard Disk Bay Cover
(3.5G Module Location)
3. RAM & CPU Bay Cover
4. Vent

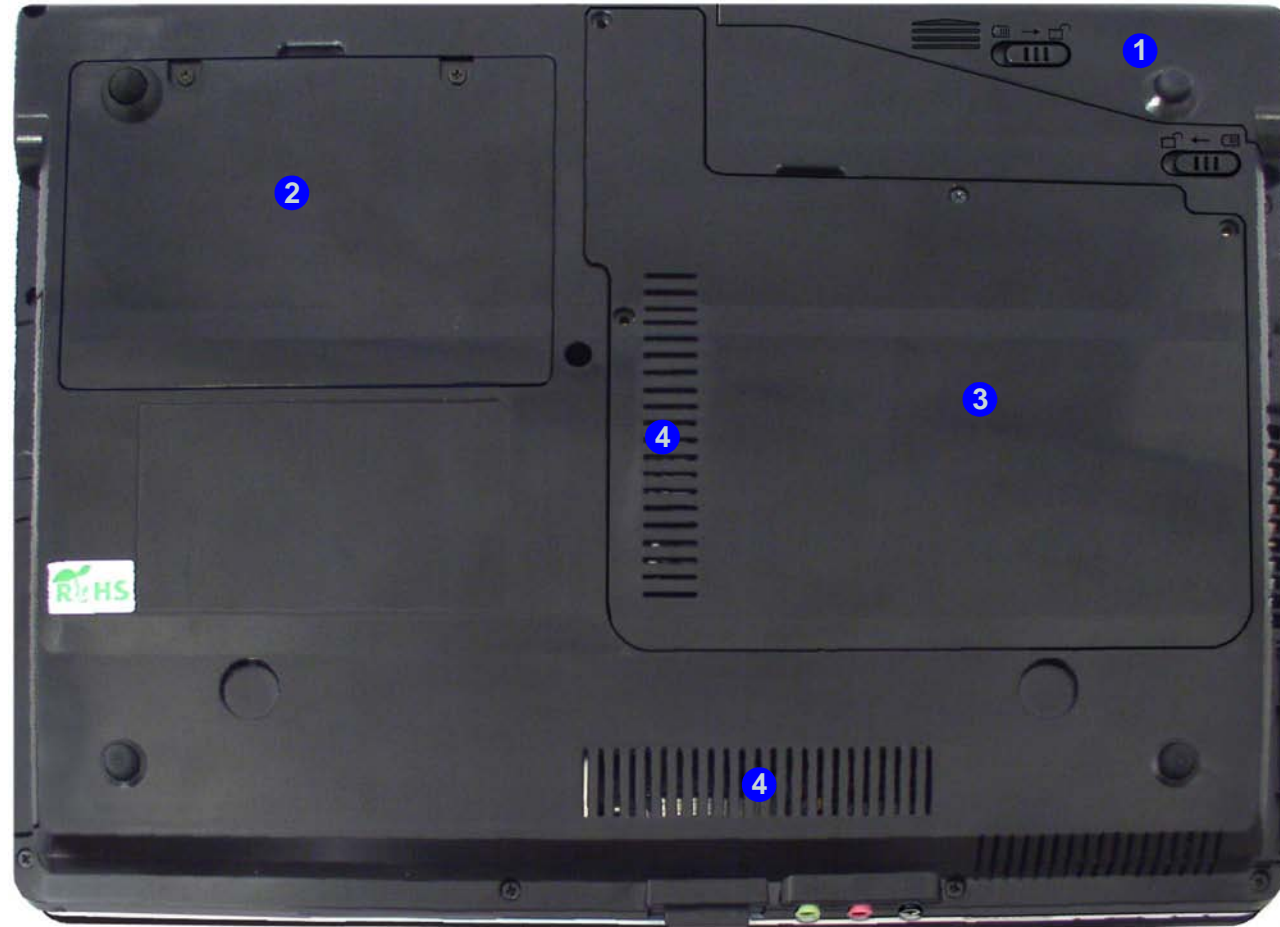

Overheating

To prevent your computer from overheating make sure nothing blocks the vent/fan intakes while the computer is in use.

Mainboard Overview - Top (Key Parts)

Figure 7
**Mainboard Top
Key Parts**

1. Clock Buffer
2. ITE 8512E
3. Card Reader
Controller ENE
MR510
4. RTL 8111B

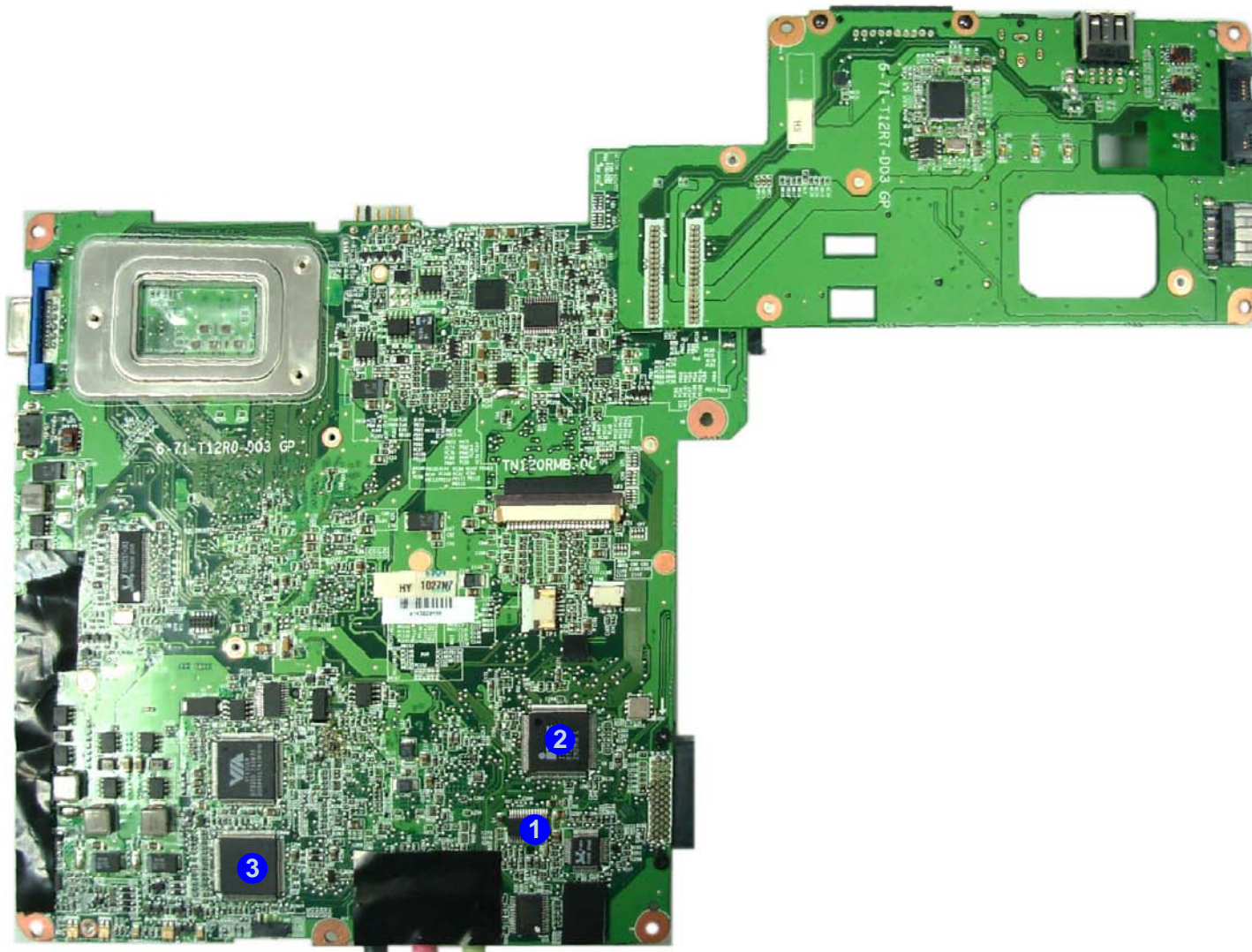

Introduction

Figure 8
**Mainboard Bottom Key
Parts**

1. CPU Socket (no CPU installed)
2. Northbridge-intel GM965
3. ExpressCard Assembly
4. Southbridge-ICH8-M
5. Memory Slots DDRII So-DIMM
6. WLAN Mini Card Slot
7. SIM Card Slot
8. 3.5G Mini Card Slot

Mainboard Overview - Bottom (Key Parts)

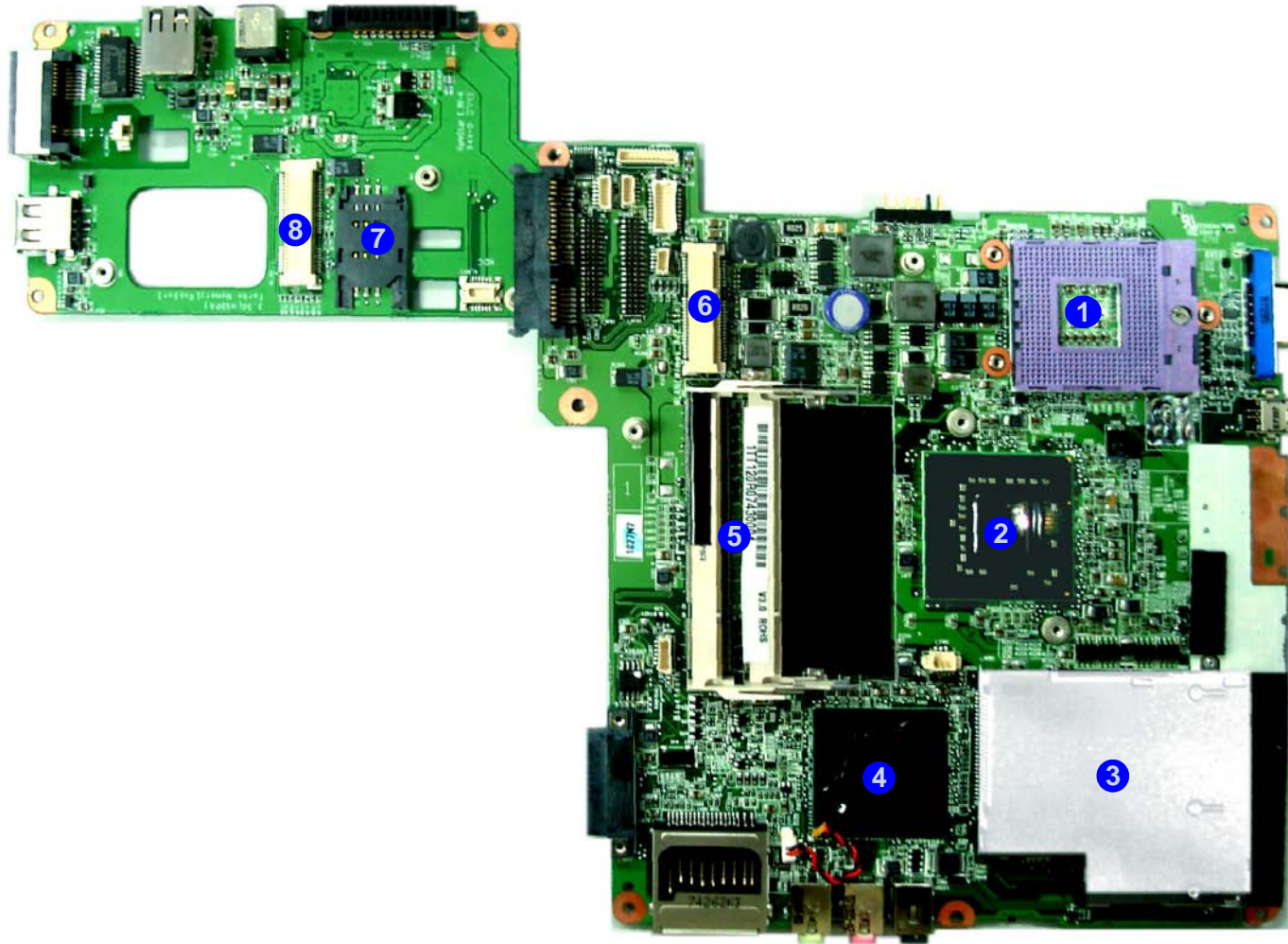

Mainboard Overview - Top (Connectors)

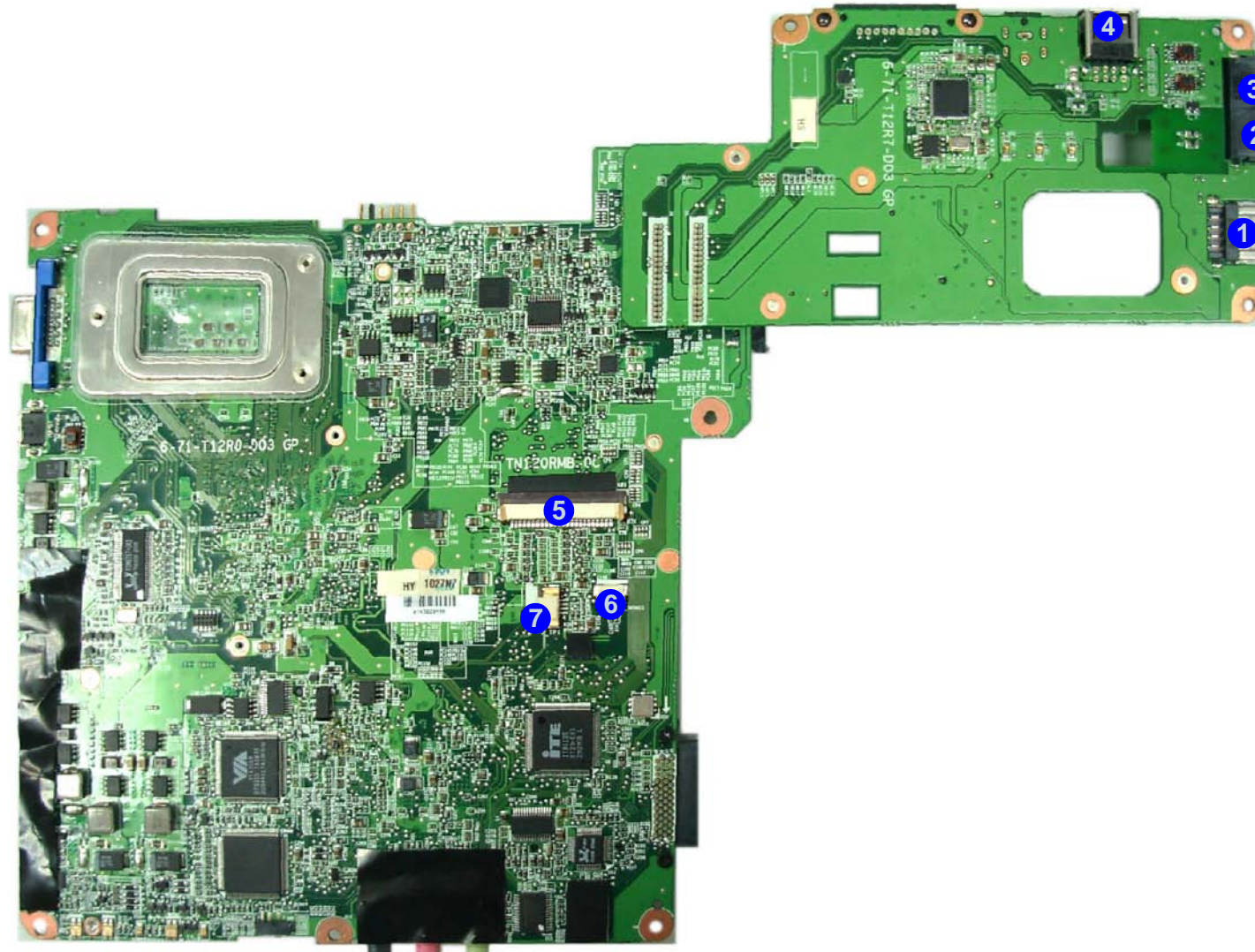

Figure 9
**Mainboard Top
Connectors**

1. USB Port
2. RJ-11 Phone Jack
3. RJ-45 LAN Jack
4. 2 *USB Port
5. Keyboard Cable Connector
6. Internal
Microphone Cable
Connector
7. Touch Pad Cable
Connector
Battery
Connector

Introduction

Figure 10
**Mainboard Bottom
 Connectors**

Mainboard Overview - Bottom (Connectors)

1. Mini-IEEE 1394 Port
2. External Monitor Port
3. Battery Connector
4. DC-In Jack
5. 2 * USB 2.0 Ports
6. USB 2.0 Ports
7. Optical Device Drive Connector
8. 7-in-1 Card Reader
9. Headphone-Out Jack
10. Microphone-In Jack
11. S/PDIF-Out Jack
12. Fan Cable Connector
13. Bluetooth Cable Connector
14. Speaker Cable Connector
15. LCD Cable Connector
16. DC-In Jack
17. CCD Cable Connector
18. Fingerprint Cable Connector

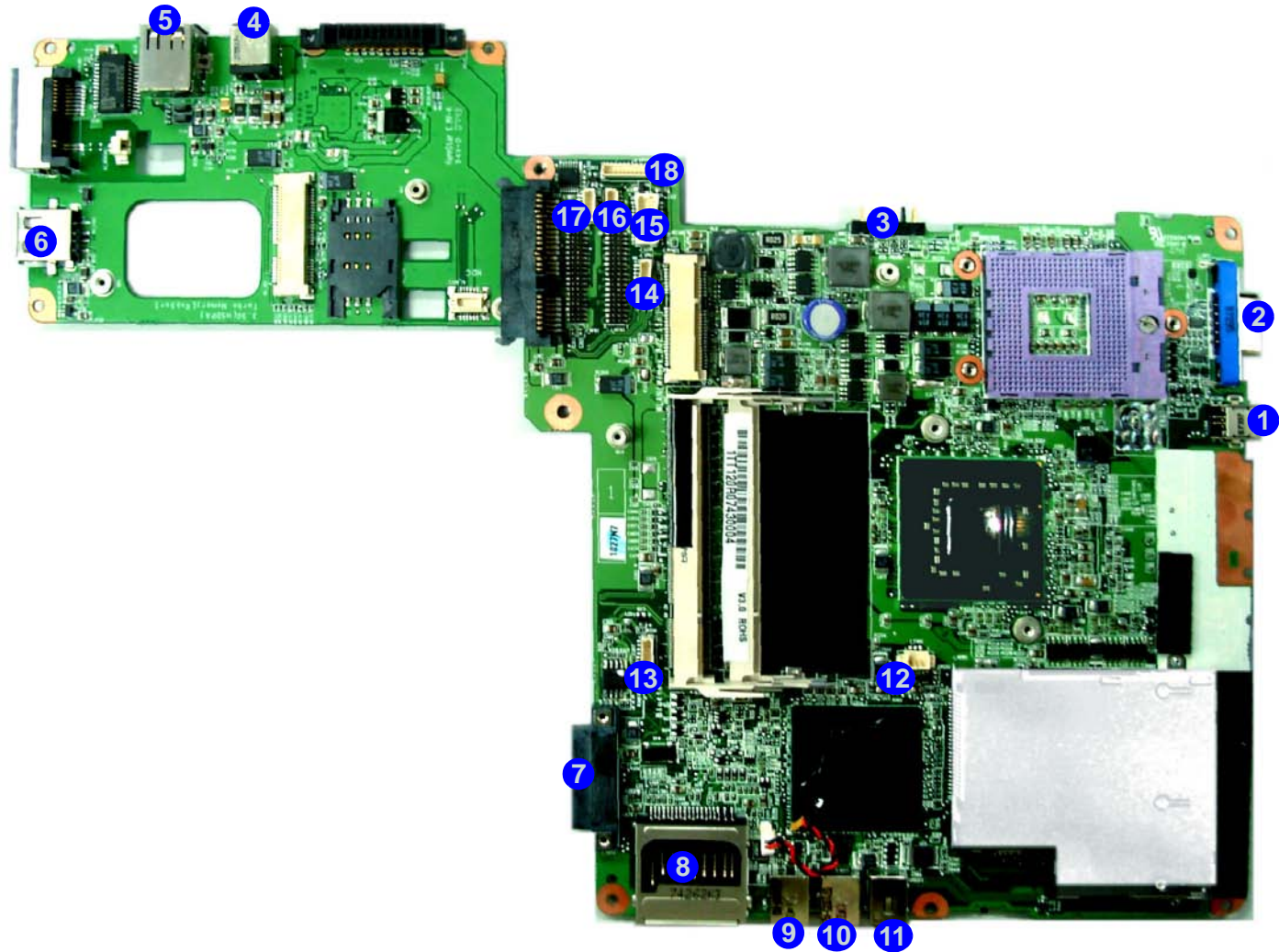

Chapter 2: Disassembly



Overview

This chapter provides step-by-step instructions for disassembling the *TN120R* series notebook's parts and subsystems. When it comes to reassembly, reverse the procedures (unless otherwise indicated).

We suggest you completely review any procedure before you take the computer apart.

Procedures such as upgrading/replacing the RAM, CD device and hard disk are included in the User's Manual but are repeated here for your convenience.

To make the disassembly process easier each section may have a box in the page margin. Information contained under the figure # will give a synopsis of the sequence of procedures involved in the disassembly procedure. A box with a  lists the relevant parts you will have after the disassembly process is complete. **Note:** The parts listed will be for the disassembly procedure listed ONLY, and not any previous disassembly step(s) required. Refer to the part list for the previous disassembly procedure. The amount of screws you should be left with will be listed here also.

A box with a  will also provide any possible helpful information. A box with a  contains warnings.

An example of these types of boxes are shown in the sidebar.

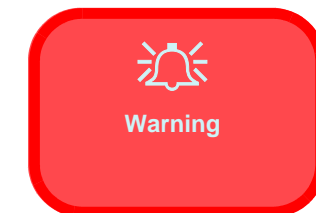
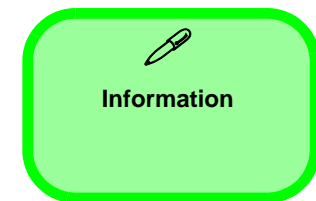

Disassembly

NOTE: All disassembly procedures assume that the system is turned **OFF**, and disconnected from any power supply (the battery is removed too).

Maintenance Tools

The following tools are recommended when working on the notebook PC:

- M3 Philips-head screwdriver
- M2.5 Philips-head screwdriver (magnetized)
- M2 Philips-head screwdriver
- Small flat-head screwdriver
- Pair of needle-nose pliers
- Anti-static wrist-strap

Connections

Connections within the computer are one of four types:

Locking collar sockets for ribbon connectors	To release these connectors, use a small flat-head screwdriver to gently pry the locking collar away from its base. When replacing the connection, make sure the connector is oriented in the same way. The pin1 side is usually not indicated.
Pressure sockets for multi-wire connectors	To release this connector type, grasp it at its head and gently rock it from side to side as you pull it out. Do not pull on the wires themselves. When replacing the connection, do not try to force it. The socket only fits one way.
Pressure sockets for ribbon connectors	To release these connectors, use a small pair of needle-nose pliers to gently lift the connector away from its socket. When replacing the connection, make sure the connector is oriented in the same way. The pin1 side is usually not indicated.
Board-to-board or multi-pin sockets	To separate the boards, gently rock them from side to side as you pull them apart. If the connection is very tight, use a small flat-head screwdriver - use just enough force to start.

Maintenance Precautions

The following precautions are a reminder. To avoid personal injury or damage to the computer while performing a removal and/or replacement job, take the following precautions:

1. **Don't drop it.** Perform your repairs and/or upgrades on a stable surface. If the computer falls, the case and other components could be damaged.
2. **Don't overheat it.** Note the proximity of any heating elements. Keep the computer out of direct sunlight.
3. **Avoid interference.** Note the proximity of any high capacity transformers, electric motors, and other strong magnetic fields. These can hinder proper performance and damage components and/or data. You should also monitor the position of magnetized tools (i.e. screwdrivers).
4. **Keep it dry.** This is an electrical appliance. If water or any other liquid gets into it, the computer could be badly damaged.
5. **Be careful with power.** Avoid accidental shocks, discharges or explosions.
 - Before removing or servicing any part from the computer, turn the computer off and detach any power supplies.
 - When you want to unplug the power cord or any cable/wire, be sure to disconnect it by the plug head. Do not pull on the wire.
6. **Peripherals** – Turn off and detach any peripherals.
7. **Beware of static discharge.** ICs, such as the CPU and main support chips, are vulnerable to static electricity. Before handling any part in the computer, discharge any static electricity inside the computer. When handling a printed circuit board, do not use gloves or other materials which allow static electricity buildup. We suggest that you use an anti-static wrist strap instead.
8. **Beware of corrosion.** As you perform your job, avoid touching any connector leads. Even the cleanest hands produce oils which can attract corrosive elements.
9. **Keep your work environment clean.** Tobacco smoke, dust or other air-borne particulate matter is often attracted to charged surfaces, reducing performance.
10. **Keep track of the components.** When removing or replacing any part, be careful not to leave small parts, such as screws, loose inside the computer.

Cleaning

Do not apply cleaner directly to the computer, use a soft clean cloth.

Do not use volatile (petroleum distillates) or abrasive cleaners on any part of the computer.



Power Safety Warning

Before you undertake any upgrade procedures, make sure that you have turned off the power, and disconnected all peripherals and cables (including telephone lines). It is advisable to also remove your battery in order to prevent accidentally turning the machine on.

Disassembly Steps

The following table lists the disassembly steps, and on which page to find the related information. **PLEASE PERFORM THE DISASSEMBLY STEPS IN THE ORDER INDICATED.**

To remove the Battery:

1. Remove the battery [page 2 - 5](#)

To remove the HDD:

1. Remove the battery [page 2 - 5](#)
2. Remove the HDD [page 2 - 6](#)

To remove the Modem :

1. Remove the battery [page 2 - 5](#)
2. Remove the HDD [page 2 - 6](#)
3. Remove the modem [page 2 - 8](#)

To remove the System Memory:

1. Remove the battery [page 2 - 5](#)
2. Remove the system memory [page 2 - 9](#)

To remove the Processor:

1. Remove the battery [page 2 - 5](#)
2. Remove the processor [page 2 - 11](#)

To remove the Wireless LAN Module:

1. Remove the battery [page 2 - 5](#)
2. Remove the Wireless LAN [page 2 - 14](#)

To remove the Bluetooth:

1. Remove the battery [page 2 - 5](#)
2. Remove the bluetooth [page 2 - 15](#)

To remove the Optical Device:

1. Remove the battery [page 2 - 5](#)
2. Remove the Optical device [page 2 - 16](#)

To remove the Keyboard:

1. Remove the battery [page 2 - 5](#)
2. Remove the keyboard [page 2 - 17](#)

Removing the Battery

1. Turn the computer **off**, and turn it over.
2. Slide the latch **1** in the direction of the arrow, and hold latch **2** in place.
3. Slide the battery **4** in the direction of the arrow **3**.

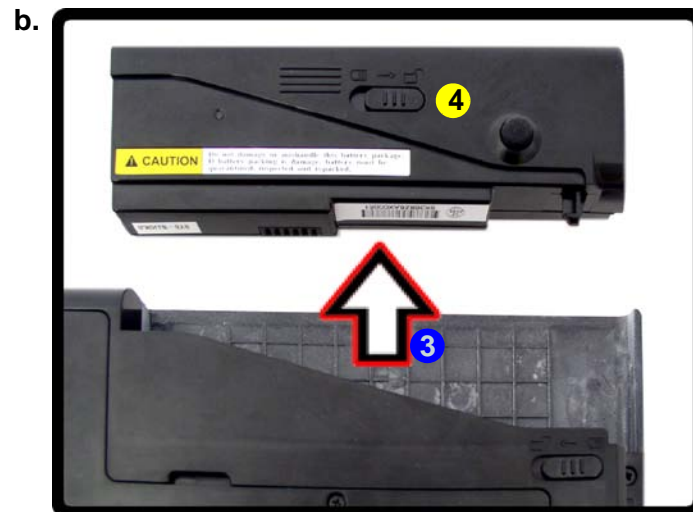
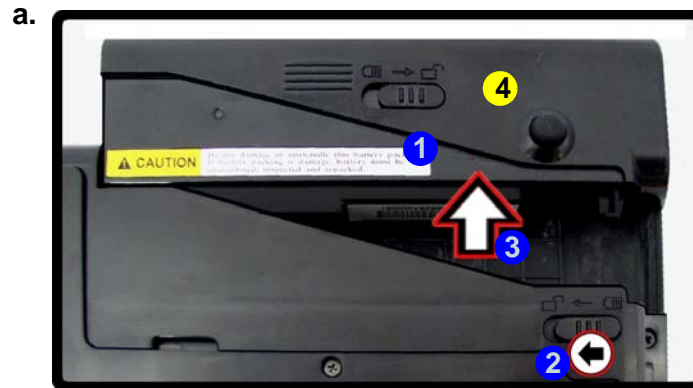
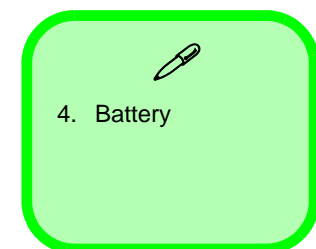

Figure 1
Battery Removal

- a. Slide the 2 latches and hold latch **2** in place.
- b. Slide the battery in the direction of the arrow.



Disassembly

Figure 2
**HDD Assembly
Removal**

- Locate the HDD bay cover and remove the screws.
- Remove the bay cover.

Removing the Hard Disk Drive

The hard disk drive can be taken out to accommodate other 2.5" serial (SATA) hard disk drives with a height of 9.5mm (h). Follow your operating system's installation instructions, and install all necessary drivers and utilities (as outlined in **Chapter 4 of the User's Manual**) when setting up a new hard disk.

Hard Disk Upgrade Process:

- Turn **off** the computer, and remove the battery ([page 2 - 5](#)).
- Locate the hard disk bay cover and remove the screws (1 - 2).
- Remove the bay cover (3).

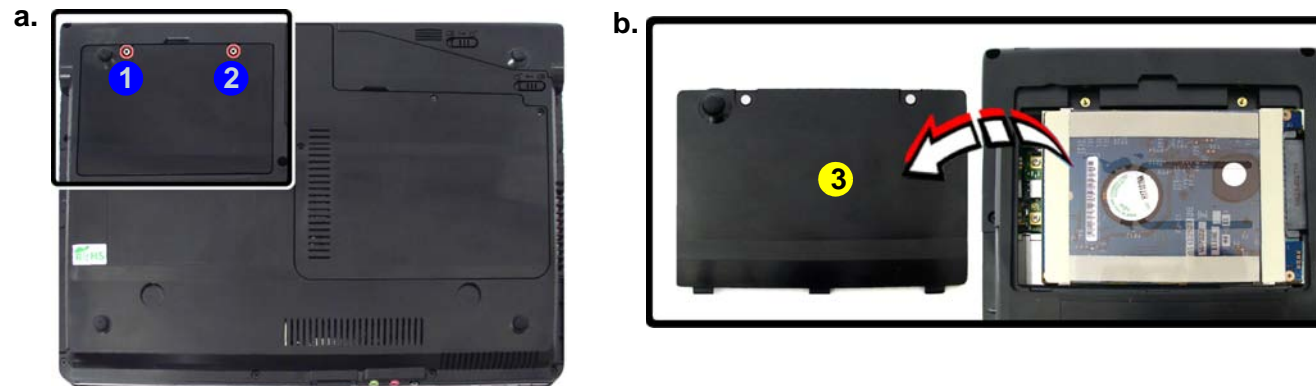

3. HDD Bay Cover

- 2 Screws



HDD System Warning

New HDD's are blank. Before you begin make sure:

You have backed up any data you want to keep from your old HDD.

You have all the CD-ROMs and FDDs required to install your operating system and programs.

If you have access to the internet, download the latest application and hardware driver updates for the operating system you plan to install. Copy these to a removable medium.

- Carefully grip the mylar tab **4** and slide the hard disk in the direction of arrow
- Lift the hard disk up (**Figure d**) in the direction of arrow.
- Remove the screws **5** - **6** and separate the mylar cover **7** from the hard disk **8**.
- Reverse the process to install any new hard disk.

Figure 3
**HDD Assembly
Removal Sequence**

- Slide the HDD in the direction of the arrow.
- Lift the HDD out of the bay.
- Remove the screws and separate the mylar cover from the HDD .

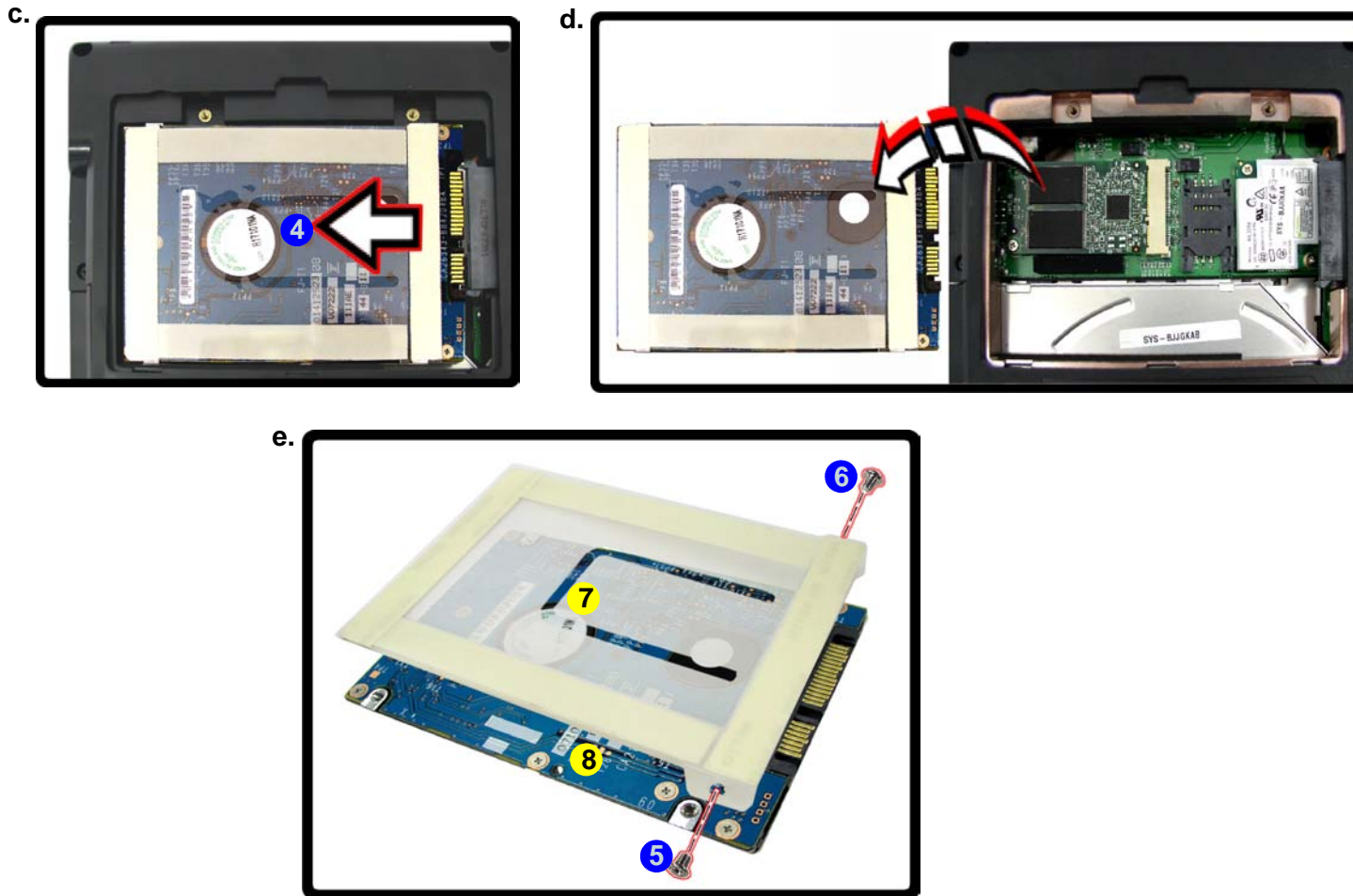

7. Mylar Cover
8. HDD

- 2 Screws

Disassembly

Figure 4
Modem Removal

- a. Remove the hard disk
 - b. Remove the screws.
 - c. Lift the modem up off the socket and disconnect the connector from the modem.
 - d. Remove the modem.
1. Turn off the computer, remove the battery ([page 2 - 5](#)) and the hard disk ([page 2 - 6](#)).
 2. The modem will be visible at point ① under the hard disk.
 3. Remove screws ② - ③.
 4. Lift the modem up off the socket ④ and disconnect the connector ⑤ from the modem.
 5. Lift the modem ⑥ up and off the computer.

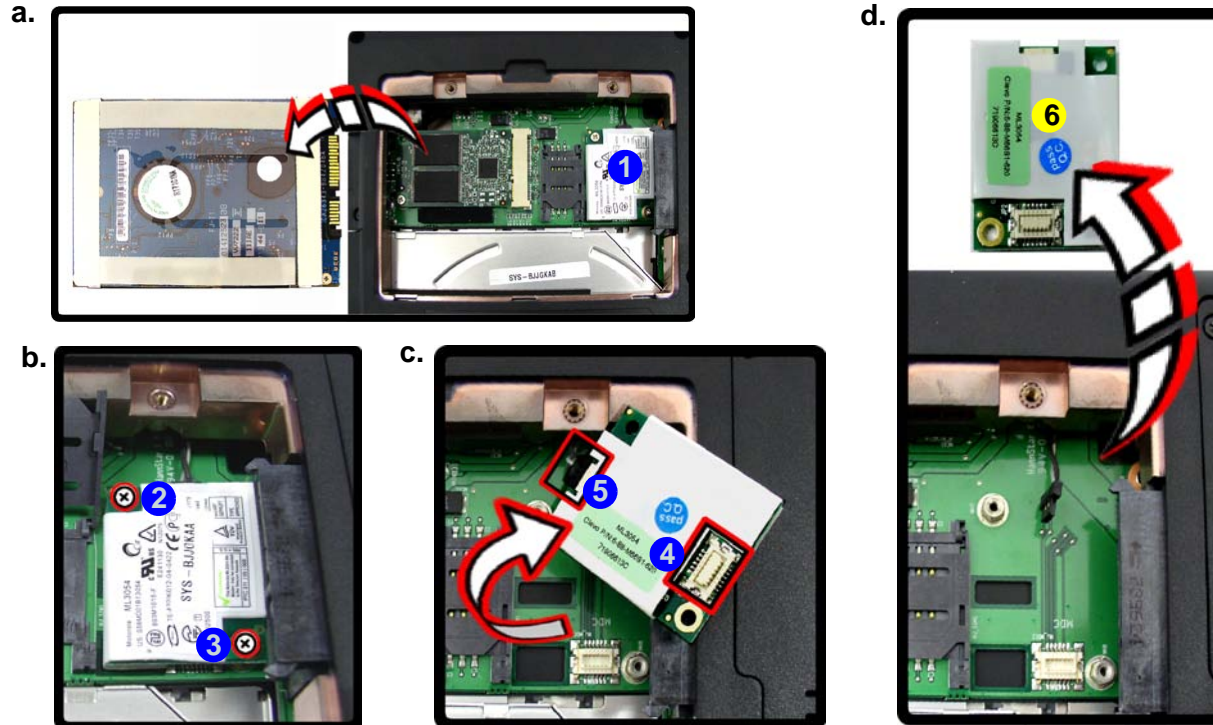

6. Modem

- 2 Screws

Removing the System Memory (RAM)

The computer has two memory sockets for 200 pin Small Outline Dual In-line Memory Modules (SO-DIMM) supporting **DDRII** 533/667MHz. The main memory can be expanded up to 4GB. The SO-DIMM modules supported are 256MB, 512MB and 1024MB **DDRII** Modules. The total memory size is automatically detected by the POST routine once you turn on your computer.

Memory Upgrade Process

1. Turn **off** the computer, remove the battery ([page 2 - 5](#)).
2. Locate the CPU/RAM bay cover, and remove screws **1** - **4**.
3. Carefully (a fan and cable are attached to the under side of the cover) lift up the bay cover.
4. Carefully disconnect the fan cable **5**.
5. Remove the bay cover **6**.
6. The RAM will be visible at point **7** on the mainboard.

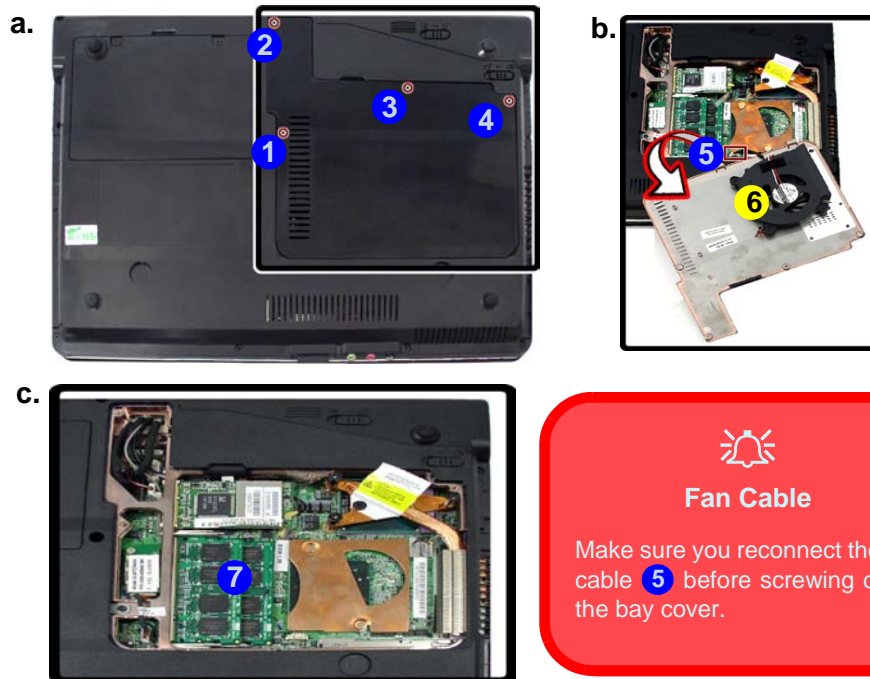

Fan Cable
 Make sure you reconnect the fan cable **5** before screwing down the bay cover.

6. CPU/RAM Bay Cover

- 4 Screws

Contact Warning
 Be careful not to touch the metal pins on the module's connecting edge. Even the cleanest hands have oils which can attract particles, and degrade the module's performance.

Figure 5
RAM Module Removal

- a. Remove the screws.
- b. Disconnect the fan cable and the cover.
- c. Locate the RAM module.

Disassembly

Figure 6 Memory Removal Sequence

- d. Push the release latch(es).
e. Remove the module(s).
f. Make sure you reconnect the fan cable.

7. Gently push the two release latches (8 & 9) on the sides of the memory socket in the direction indicated by the arrows (Figure d).
8. The RAM module(s) 10 will pop-up (Figure e), and you can then remove it.

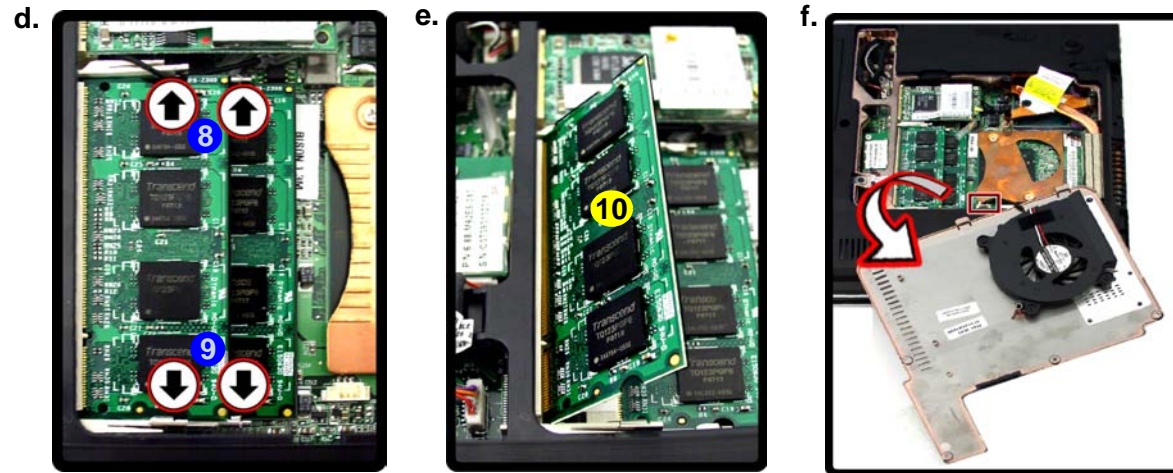

9. Push the latches to release the second module if necessary.
10. Insert a new module holding it at about a 30° angle and fit the connectors firmly into the memory slot.
11. The module will only fit one way as defined by its pin alignment. Make sure the module is seated as far into the slot as it will go. DO NOT FORCE IT; it should fit without much pressure.
12. Press the module down towards the mainboard until the slot levers click into place to secure the module.
13. Replace the bay cover and the screws (make sure you reconnect the fan cable before screwing down the bay cover - Figure f).
14. Restart the computer to allow the BIOS to register the new memory configuration as it starts up.



10 RAM Module(s)

Removing the Processor

1. Turn **off** the computer, and remove the battery ([page 2 - 5](#)) and the CPU/RAM bay cover ([page 2 - 9](#)).
2. Loosen the heat sink screws **3** - **1** (IN THE ORDER 3, 2, 1 AS INDICATED ON THE HEAT SINK - See below).



CPU Heat Sink Screws

In order to prevent damage to the CPU it is very important that the heat sink screws are loosened in the correct order.

There are numbers printed on the heat sink. **The order in which the screws should be loosened, depends on whether you are removing the CPU, or installing the CPU.**

When **REMOVING** the heat sink unit **loosen the screws in the order 3, 2, 1** (as printed on the heat sink). **Figure b** indicates the correct order to loosen the screws when removing the heat sink unit.

a.

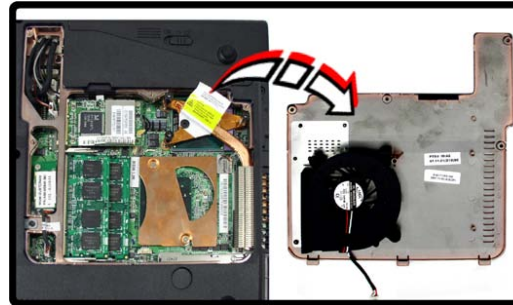

b. HEAT SINK REMOVAL

Loosen screw **3** FIRST.

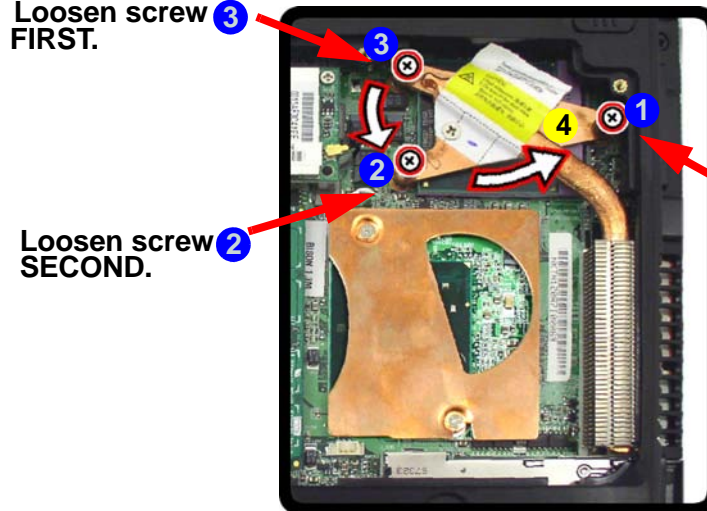

Loosen screw **1** THIRD.

Figure 7
Processor Removal

- a. Remove the cover and locate the heat sink.
- b. Remove the 3 screws in the order indicated.



4. Heat Sink

- 3 Screws

Disassembly

Figure 8
Processor Removal Sequence

- c. Remove the heat sink.
- d. Turn the release latch to unlock the CPU.
- e. Lift the CPU out of the socket.

3. When the screws are loosened sufficiently, carefully lift up the heat sink **4** (*Figure c*) off the computer.
4. Turn the release latch **5** towards the unlock symbol , to release the CPU (*Figure d*).
5. Carefully (it may be hot) lift the CPU **6** up out of the socket (*Figure e*).
6. When re-inserting the CPU, pay careful attention to the pin alignment, it will fit only one way (DO NOT FORCE IT!).

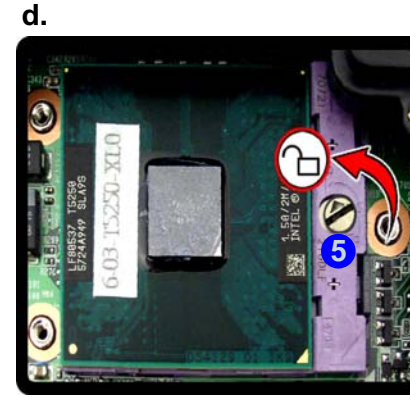

Unlock

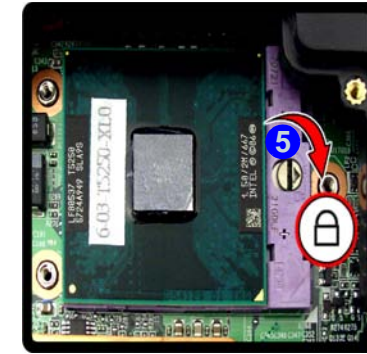

Lock

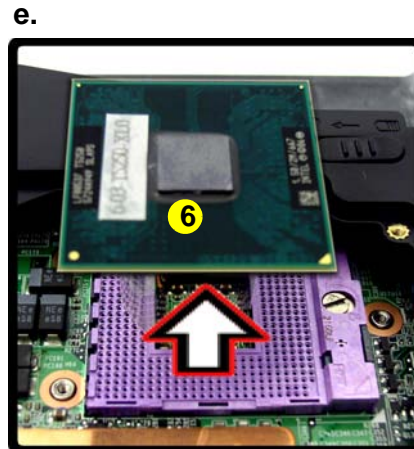

Caution

The heat sink, and CPU area in general, contains parts which are subject to high temperatures. Allow the area time to cool before removing these parts.

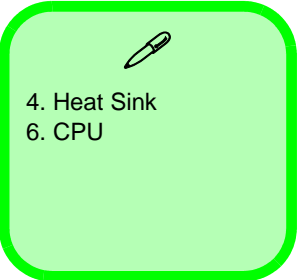
- 
- 4. Heat Sink
 - 6. CPU

7. Tighten the screws ① - ③ (IN THE ORDER 1, 2, 3 AS INDICATED ON THE HEAT SINK - See below).
8. Replace the CPU/RAM bay cover and screws.

Figure 9
Processor Removal
Sequence

f. Tighten the 3 screws in the order indicated.



CPU Heat Sink Screws

In order to prevent damage to the CPU it is very important that the heat sink screws are loosened in the correct order.

There are numbers printed on the heat sink. The order in which the screws should be loosened, depends on whether you are removing the CPU, or installing the CPU.

When **INSTALLING** the heat sink unit tighten the screws in the order 1, 2, 3 (as printed on the heat sink). Figure f indicates the correct order to tighten the screws when installing the heat sink unit.

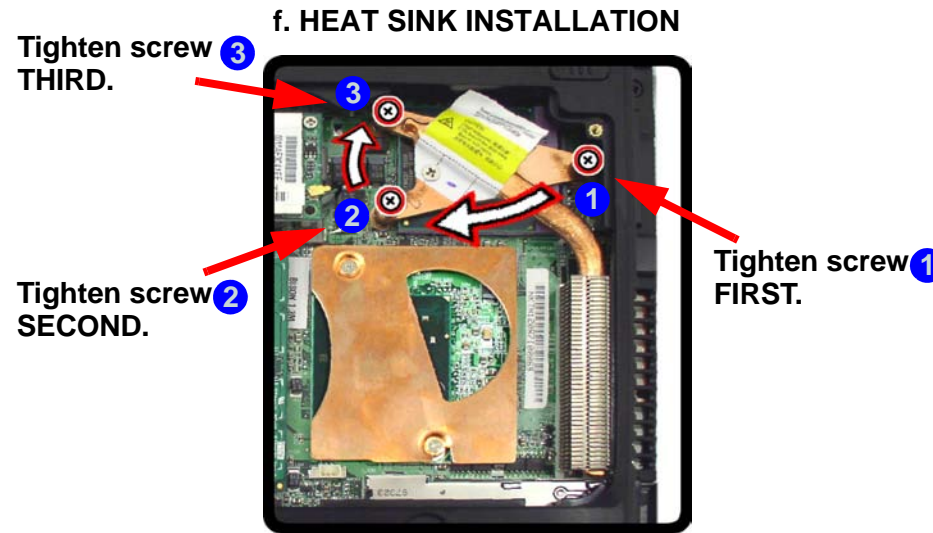

Disassembly

Figure 10
Wireless LAN Module Removal

- Remove the cover and locate the heat sink.
- Disconnect the cable and remove the screw.
- The WLAN module will pop up.
- Remove the WLAN module.

Note: Make sure you reconnect the antenna cable to the “Main” socket (*Figure b*).

Removing the Wireless LAN Module

- Turn **off** the computer, remove the battery ([page 2 - 5](#)) and the CPU/RAM bay cover ([page 2 - 9](#)).
- The Wireless LAN module will be visible at point **1** on the mainboard.
- Carefully disconnect cable **2**, then remove the screw **3** from the module socket.
- The Wireless LAN module **4** will pop-up.
- Lift the Wireless LAN module (*Figure d*) up and off the computer.

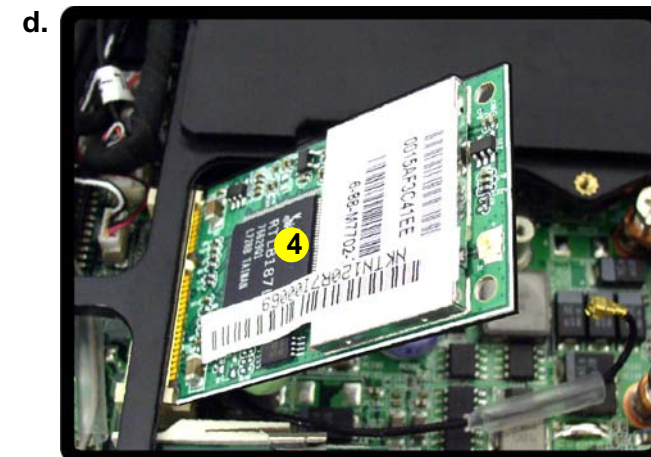
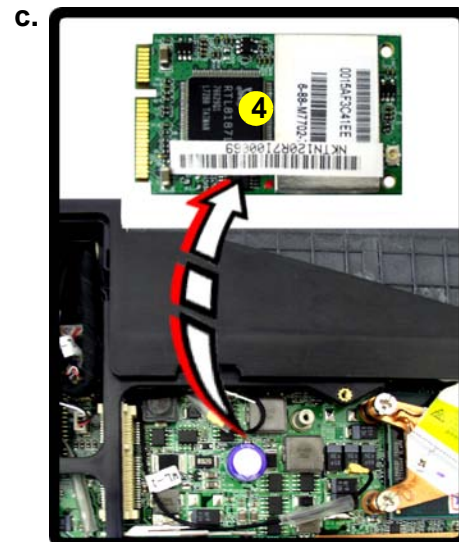
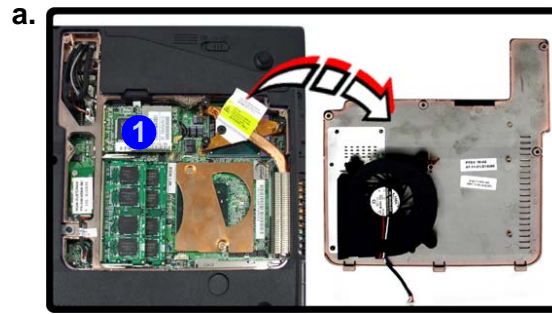

4. WLAN Module

- 1 Screw

Removing the Bluetooth Module

1. Turn **off** the computer, remove the battery ([page 2 - 5](#)), and the CPU/RAM bay cover ([page 2 - 9](#)).
2. The Bluetooth module will be visible at point **1** on the mainboard.
3. Remove screw **2** and turn it over.
4. Carefully disconnect the cable **3** and separate the module from the connector **4**.
5. Lift the Bluetooth module **5** up and off the computer.

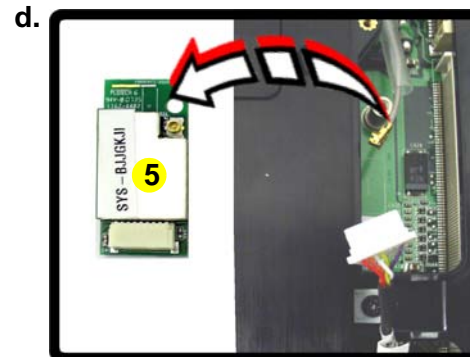
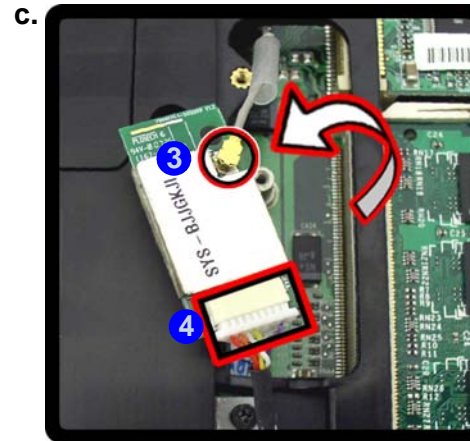
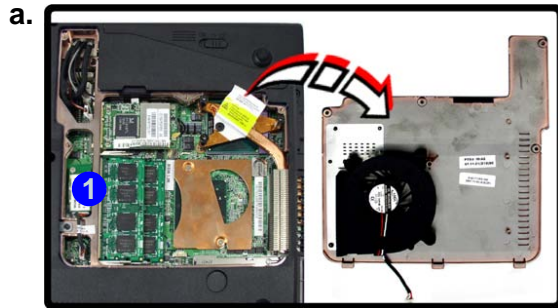
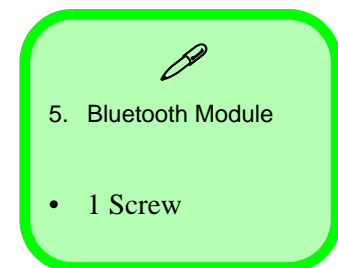

Figure 11
Bluetooth Removal

- a. Remove the cover and locate the Bluetooth module.
- b. Remove the screw.
- c. Disconnect the cable and separate the connector.
- d. Lift the Bluetooth module out.



Disassembly

Figure 12
**Optical Device
 Removal**

- a. Remove the cover and locate the screw.
- b. Remove the screw and push the optical device out off the computer at point 2 and remove the optical device.

Removing the Optical (CD/DVD) Device

1. Turn off the computer, remove the battery ([page 2 - 5](#)), and the CPU/RAM bay cover ([page 2 - 9](#)).
2. Remove the screw at point ①, and use a screwdriver to carefully push out the optical device at point ②.
3. Insert the new device and carefully slide it into the computer (the device only fits one way. DO NOT FORCE IT; The screw holes should line up).
4. Insert the new device and replace the optical device screw ①.
5. **Reconnect the fan cable before replacing the bay cover** (⑤ in [Figure 5 on page 2 - 9](#)).
6. Replace the bay cover and screws.
7. Restart the computer to allow it to automatically detect the new device.

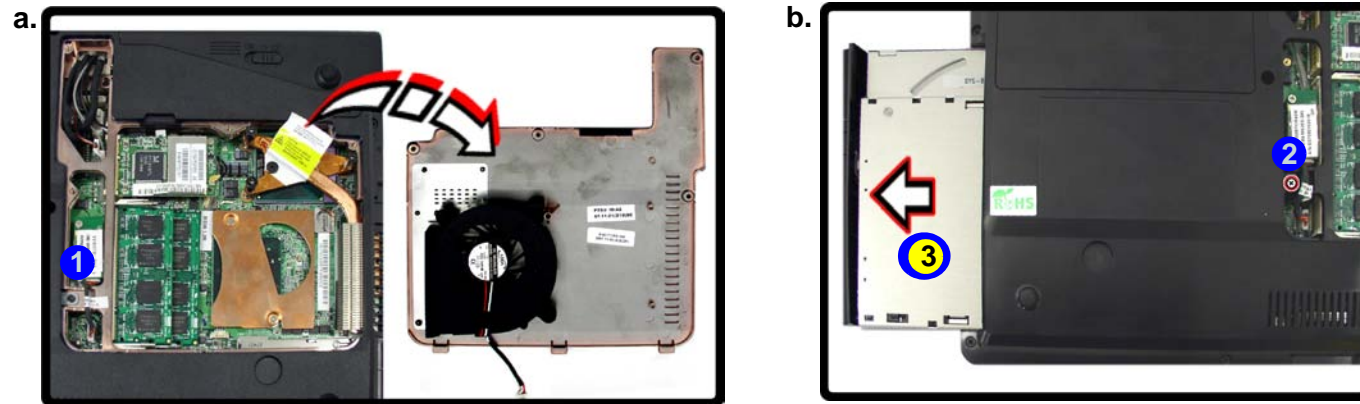

3. Optical Device

- 1 Screw

Removing the Keyboard

1. Turn **off** the computer, and remove the battery ([page 2 - 5](#)).
2. Press the **three** keyboard latches at the top of the keyboard to elevate the keyboard from its normal position (you may need to use a small screwdriver to do this).
3. Carefully lift the keyboard up, being careful not to bend the keyboard ribbon cable ([Figure b](#)).
4. Disconnect the keyboard ribbon cable **4** from the locking collar socket **5**.
5. Carefully lift up the keyboard **6** ([Figure c](#)) off the computer.

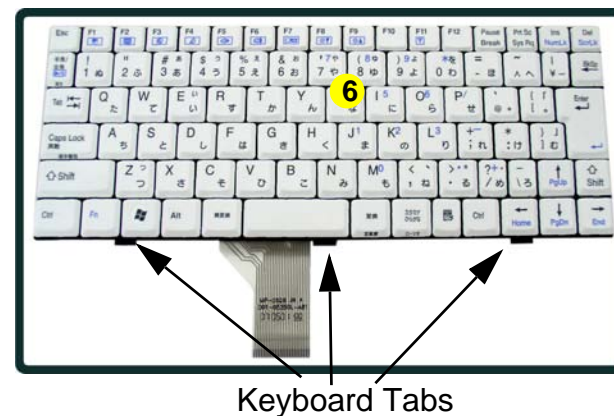
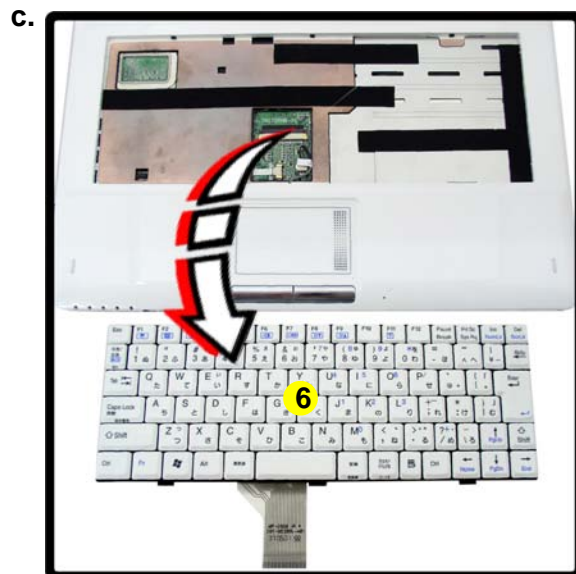
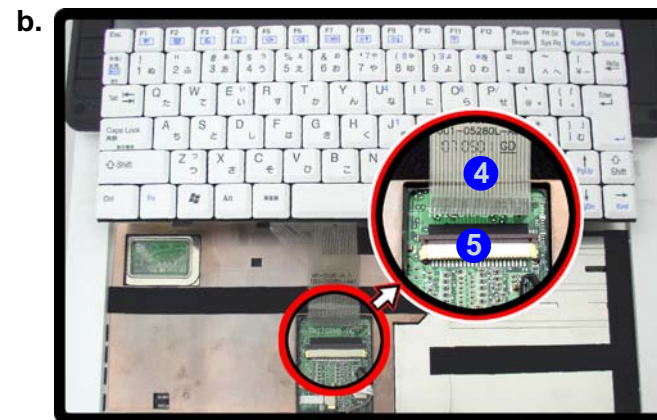
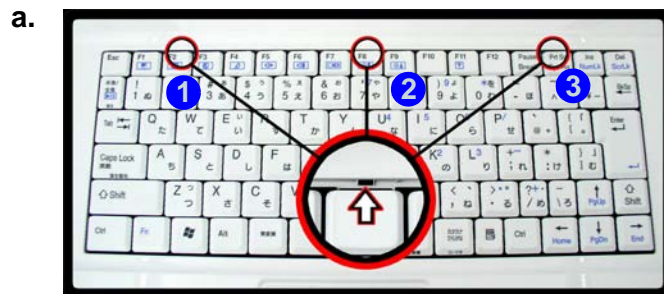



Figure 13
Keyboard Removal

- a. Press the three latches to release the keyboard.
- b. Lift the keyboard up and disconnect the cable from the locking collar.
- c. Remove the keyboard.

Re-Inserting the Keyboard

When re-inserting the keyboard firstly align the **three** keyboard tabs at the bottom of the keyboard with the slots in the case.

6. Keyboard Module.

Appendix A:Part Lists

This appendix breaks down the *TN120R* series notebook's construction into a series of illustrations. The component part numbers are indicated in the tables opposite the drawings.

Note: This section indicates the *manufacturer's* part numbers. Your organization may use a different system, so be sure to cross-check any relevant documentation.

Note: Some assemblies may have parts in common (especially screws). However, the part lists DO NOT indicate the total number of duplicated parts used.

Note: Be sure to check any update notices. The parts shown in these illustrations are appropriate for the system at the time of publication. Over the product life, some parts may be improved or re-configured, resulting in *new* part numbers.

Part List Illustration Location

The following table indicates where to find the appropriate part list illustration.

Table A - 1
**Part List Illustration
Location**

Part	Pages#
Top (TN120R)	<i>page A - 3</i>
Bottom - (TN120R)	<i>page A - 4</i>
LCD - (TN120R)	<i>page A - 5</i>
Combo - (TN120R)	<i>page A - 6</i>
DVD-DUAL-RW - (TN120R)	<i>page A - 7</i>
HDD - (TN120R)	<i>page A - 8</i>

Top (TN120R)

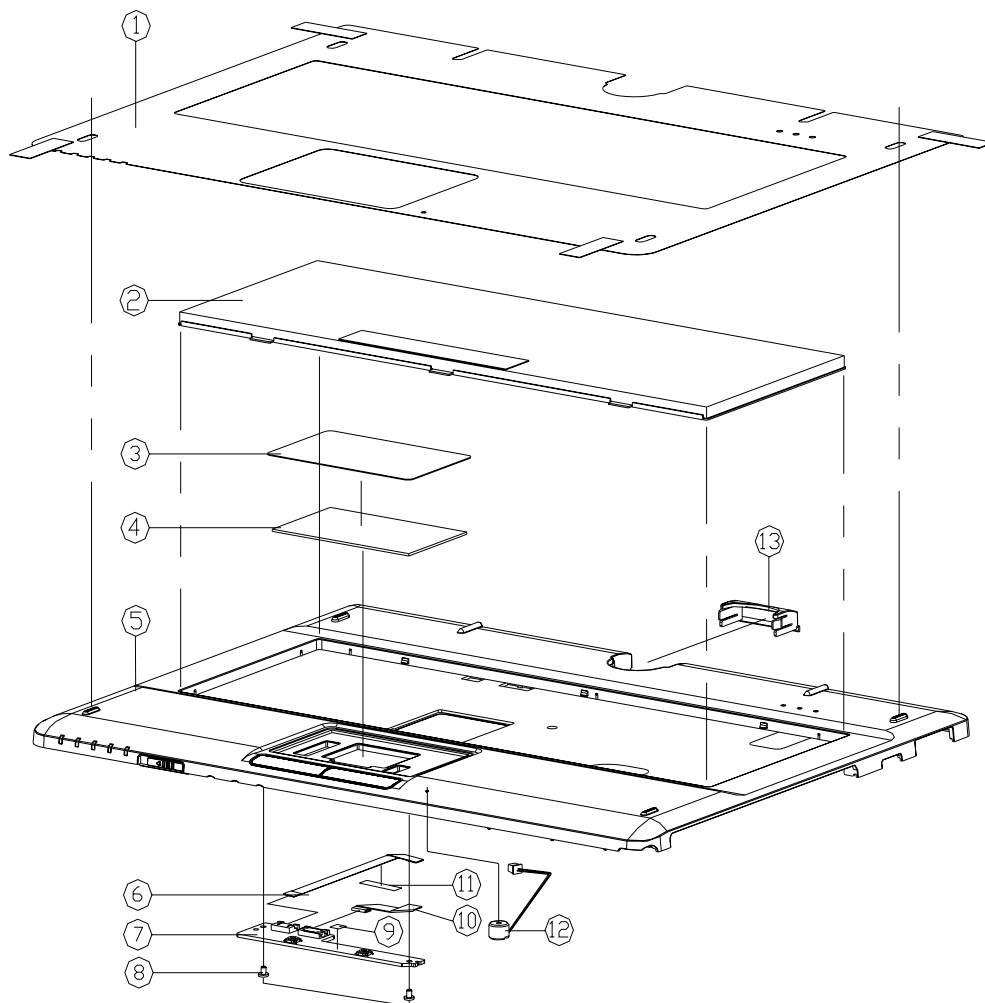

Figure A - 1
Top (TN120R)

ITEM	PART NAME	PART NO	REMARK
1	TOP CASE PROTECT MYLAR BB35 TN120R #000	6-40-T12R2-041	
2	K/B USA WP-052830S-4302 M721S #000	6-80-M7210-010-1	
3	TOUCH PAD MYLAR BB35 TN120R #000	6-40-T12R2-020	
4	TOUCH PAD TM61PDZIR389 M660JE #000	6-49-M66E2-010	
5	TOP CASE MODULE TN120R #000	6-39-T12R2-012	
6	FFC CABLE FOR CLICK TO W/B 4P TN120R #000	6-43-T12R0-010	
7	CLICK BOARD V3.0 TN120R #000	6-77-T12R2-D03	
8	SCREW M2*3L K1 NI ICT NY #000	6-35-B1120-3RA	
9	CLICK BOARD MYLAR FR83 TN120R #000	6-40-T12RS-020	
10	FFC CABLE FOR CLICK TO TOUCH PAD 12P TN120R #000	6-43-T12R2-011	
11	TAPE MYLAR (C)MYLAR M550J #000	6-40-M55J2-030	
12	TOP CASE COVER PC+ABS TN120R #000	6-23-EM55G-011	
13	TOP CASE COVER PC+ABS TN120R #000	6-42-T12R2-061	

A.Part Lists

Bottom (TN120R)

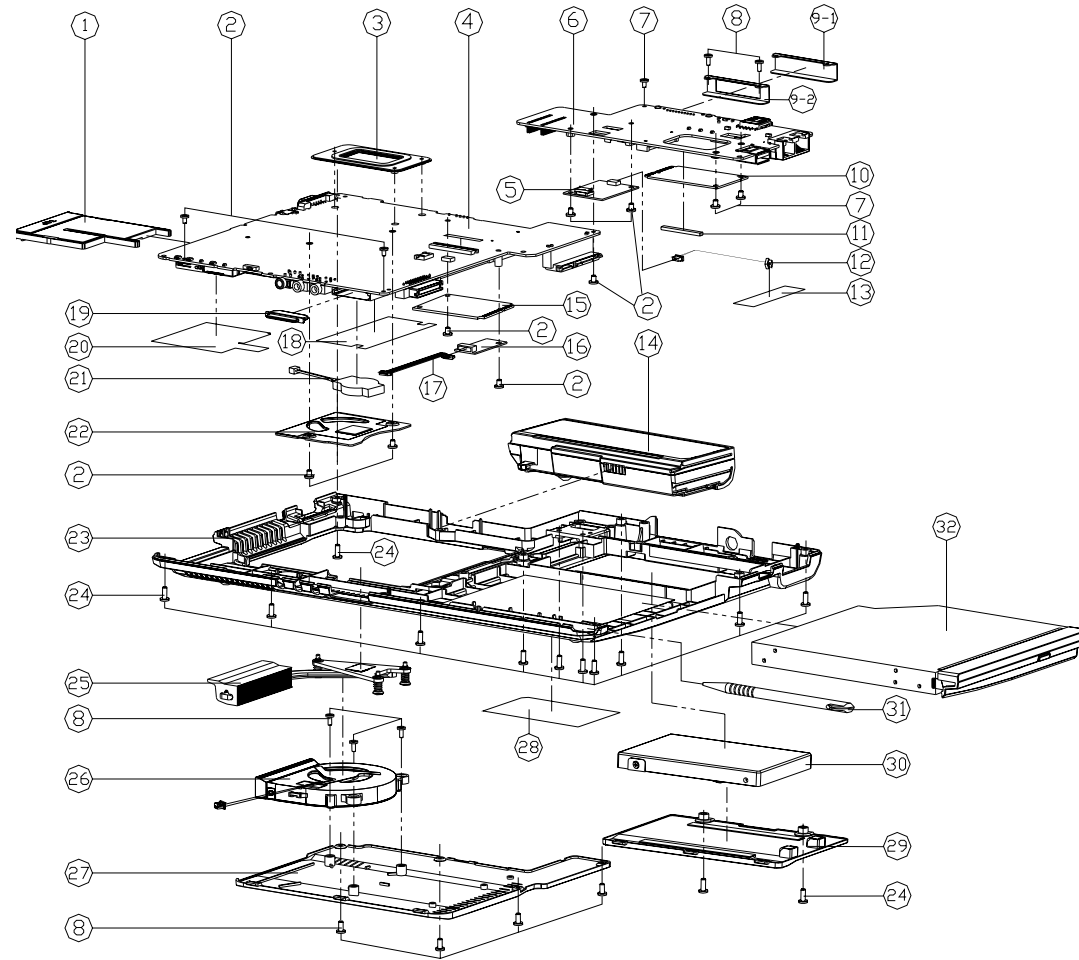
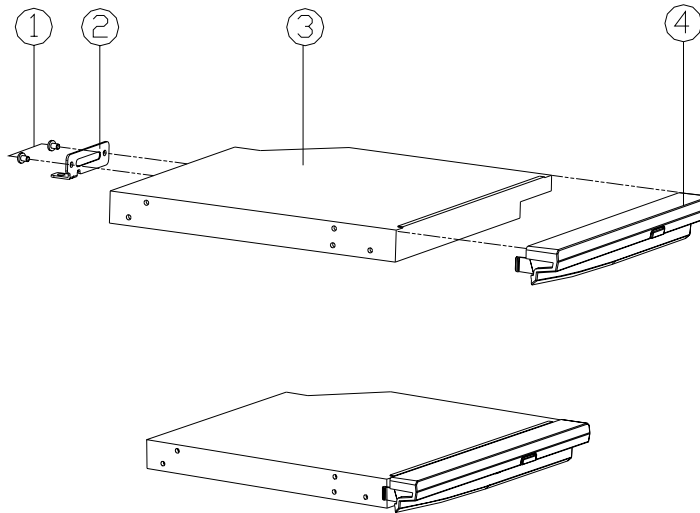

Figure A - 2
Bottom (TN120R)

ITEM	PART NAME	PART NO	REMARK
1	DUMMY NEW CARD PC+ABS TN120R	6-42-T12R3-011	
2	SCREW M2*3L K1 NI ICT NY	6-35-B1120-3RA	
3	CPU SUPPORT BRACKET,SUS M500N	6-33-M50NS-020	
4	MAIN BOARD (W/D G-SENSOR) V30 TN120R	6-77-T12R0-D03	
4	MAIN BOARD (W/D G-SENSOR) V30 TN120R	6-77-T12R0-D03-1	
5	HDD BRACKET FOR 2.5" SATA HDD (OPTION)	6-88-M55S1-531	
5	HDD BRACKET FOR 2.5" SATA HDD (OPTION)	6-88-M66S1-620	
6	MULTI FUNCTION BOARD (W/DOCKING) V30 TN120R	6-77-T12R7-D03	
6	MULTI FUNCTION BOARD (W/DOCKING) V30 TN120R	6-77-T12R7-D03-1	
7	SCREW M2.5*4 NI NI ICT GY-PATCH (B-M40)-140	6-35-B1120-3RD	
8	SCREW M2.5*4 NI NI ICT BK/Z NY	6-35-B6120-SR0	
9-1	W/D DOCKING BRACKET AL TN120R	6-33-T12RS-020	
9-2	DOCKING BRACKET AL TN120R	6-33-T12RS-011	
10	W/DOCKING RUBBER STRAPLESS (W/DOCKING) (OPTION)	6-88-M72SW-720	
11	HDD RUBBER FOR MULTI BEARING SILICONE TN120R	6-47-T12RS-010	<OPTION>
12	WIRE CABLE FOR RJ-11 TO MOD 2P M720S	6-43-M72SU-010	
13	TAPE MYLAR (C)MYLAR M550J	6-40-M55J2-030	
14	W/DOCKING RUBBER STRAPLESS (W/DOCKING) (OPTION)	6-87-T12RS-4DF	
14	W/DOCKING RUBBER STRAPLESS (W/DOCKING) (OPTION)	6-87-T12RS-4D4	
15	W/DOCKING RUBBER STRAPLESS (W/DOCKING) (OPTION)	6-88-M7702-701	
15	W/DOCKING RUBBER STRAPLESS (W/DOCKING) (OPTION)	6-88-M66N2-424	
15	W/DOCKING RUBBER STRAPLESS (W/DOCKING) (OPTION)	6-88-M66R2-420	
15	W/DOCKING RUBBER STRAPLESS (W/DOCKING) (OPTION)	6-88-M66R2-421	
15	W/DOCKING RUBBER STRAPLESS (W/DOCKING) (OPTION)	6-88-M66R2-422	
15	W/DOCKING RUBBER STRAPLESS (W/DOCKING) (OPTION)	6-88-M66R2-423	
16	W/DOCKING RUBBER STRAPLESS (W/DOCKING) (OPTION)	6-88-M5545-390	
16	W/DOCKING RUBBER STRAPLESS (W/DOCKING) (OPTION)	6-88-M5545-620	
17	WIRE CABLE FOR BLUE TOOTH TO W/B SP M720S	6-43-M72SB-010	
18	HDD SOCKET PROTECTOR (W/DOCKING) (OPTION)	6-40-M54RS-020	
19	M500G CARD READER RUBBER	6-47-M52G8-010	
20	NEW CARD MYLAR X30 FOR W/B TN120R	6-40-T12RS-010	
21	MT 20M NY ZHMB NYLON STRAP (W/DOCKING) (OPTION)	6-23-22015-P2C	
22	NORTH BRIDGE HEAT SINK CU TN120R	6-31-T12RN-012	
23	BOTTOM CASE MODULE TN120R	6-39-T12R3-012	
24	SCREW M2.5*8L KI BK/Z NY ICT	6-35-B6125-BR0	
25	CPU THERMAL MODULE TN120R	6-31-T12RS-101	
26	THERMAL CONDUCTIVE PASTE (W/DOCKING) (OPTION)	6-23-AT12R-020	
27	CPU COVER MODULE TN120R	6-42-T12RS-101	
28	PRODUCT LABEL TN120R	6-45-T12R3-011	
29	HDD COVER MODULE TN120R	6-42-T12RJ-101	
30	W/D HDD ASS'Y TN120R	6-79-T12R-J-010	
31	STYLUS PEN PDM TN120R	6-42-T12R0-012	
32	DVD/DUAL RW (SUPER MULTI) BX 051	6-79-T12R0-000	
32	COMBO 24X DVD/CDRW ASSY TN120R	6-79-T12RX-010	<OPTION>

Combo (TN120R)

Figure A - 4
Combo (TN120R)



ITEM	PART NAME	PART NO	REMARK
1	SCREW M2*3L K1 NI ICT NY <small>PH#6</small>	6-35-B1120-3RA	
2	CD-ROM LOCK BRACKET SECC COB#H# 10MM MESSG <small>PH#6</small>	6-33-M55GZ-012	
3	CD-ROM TRAY 20.8MM COBAM 30PCS 14MM C 6 MESSG <small>PH#6</small>	6-8S-907PX-C03	
4	CD-ROM BEZEL MODULE TN120R <small>PH#6</small>	6-42-T12RX-102	

DVD-DUAL-RW (TN120R)

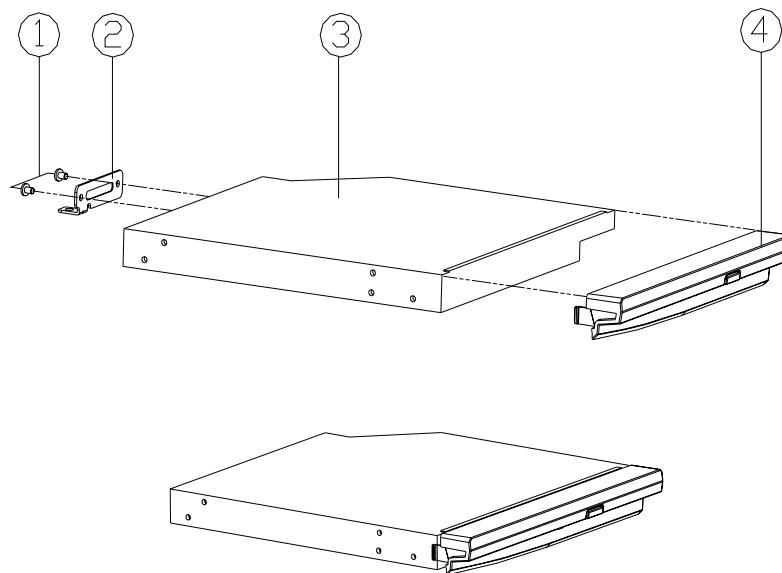

Figure A - 5
DVD-DUAL-RW
(TN120R)

ITEM	PART NAME	PART NO	REMARK
1	SCREW M2*3L K1 NI ICT NY	6-35-B1120-3RA	
2	CD-ROM LOCK BRACKET,SECC	6-33-M55GZ-012	
3	SUPER MULTI DVD RW DRIVE	6-85-A078X-C09	
3	DRIVE	6-85-A078X-T02	
4	SUPER MULTI BEZEL MODULE	6-42-T12RQ-102	

A.Part Lists

HDD (TN120R)

Figure A - 6
HDD (TN120R)

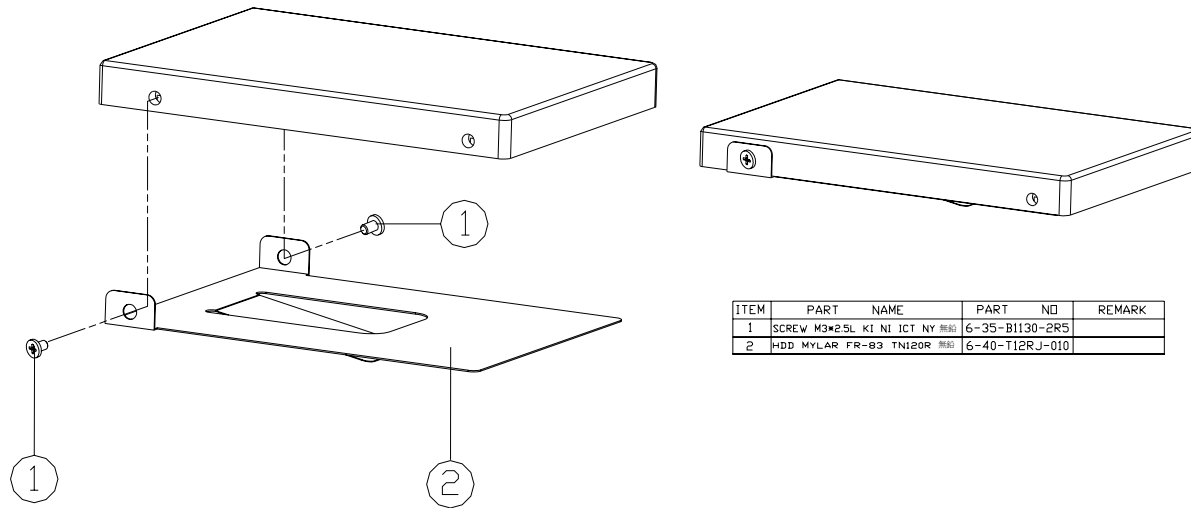

ITEM	PART NAME	PART NO	REMARK
1	SCREW M3*2.5L KI NI ICT NY #80	6-35-B1130-2R5	
2	HDD MYLAR FR-83 TN120R #80	6-40-T12RJ-010	

Appendix B:Schematic Diagrams

This appendix has circuit diagrams of the *TN120R* notebook's PCB's. The following table indicates where to find the appropriate schematic diagram.

Diagram - Page	Diagram - Page	Diagram - Page
<i>SYSTEM BLOCK DIAGRAM - Page B - 2</i>	<i>ICH8-M 4/4 - Page B - 16</i>	<i>POWER 3.3V/5V - Page B - 28</i>
<i>Merom CPU-1 - Page B - 3</i>	<i>ICH8-M 4/4 - Page B - 16</i>	<i>POWER 1.5VS/1.05VS - Page B - 29</i>
<i>Merom CPU-2 - Page B - 4</i>	<i>CLOCK GENERATOR - Page B - 17</i>	<i>POWER 1.8V/0.9V - Page B - 30</i>
<i>GM965 Crestline 1/5 - Page B - 5</i>	<i>NEW CARD, MINI PCIE - Page B - 18</i>	<i>CHARGER - Page B - 31</i>
<i>GM965 Crestline 2/5, DRAM - Page B - 6</i>	<i>IEEE 1394 VT6311S - Page B - 19</i>	<i>VCORE FOR MEROM CPU - Page B - 32</i>
<i>GM965 Crestline 3/5 - Page B - 7</i>	<i>ENE MR510, 7 IN 1 - Page B - 20</i>	<i>Multi Board, PCIE LAN RTL8111B - Page B - 33</i>
<i>GM965 Crestline 4/5 - Page B - 8</i>	<i>AUDIO CODEC ALC883 - Page B - 21</i>	<i>Multi Board, LED, USB - Page B - 34</i>
<i>GM965 Crestline 5/5 - Page B - 9</i>	<i>AUDIO AMP2056A - Page B - 22</i>	<i>Multi Board, 3G, MDC, RJ11, LID - Page B - 35</i>
<i>DDRII SO-DIMM 0 - Page B - 10</i>	<i>KBC-ITE IT8512E - Page B - 23</i>	<i>FPT ExBoard FINGERPRINT - Page B - 36</i>
<i>DDRII SO-DIMM 1 - Page B - 11</i>	<i>ODD, CCD, BT, Multi I/O - Page B - 24</i>	<i>FPT MBoard FINGERPRINT - Page B - 37</i>
<i>PANEL, INVERTER, CRT, FTP - Page B - 12</i>	<i>LED, FAN, CLICK, LID - Page B - 25</i>	<i>FPT MBoard TP, KEY, CIR - Page B - 38</i>
<i>ICH8-M 1/4, SATA - Page B - 13</i>	<i>3VS, 5VS, POWER S/W - Page B - 26</i>	<i>CLICK BOARD - Page B - 39</i>
<i>ICH8-M 2/4, PCI, USB - Page B - 14</i>	<i>POWER GPU/1.25VS - Page B - 27</i>	

Table B - 1
**Schematic
Diagrams**



Version Note

The schematic diagrams in this chapter are based upon version 6-7P-T12R5-003. If your mainboard (or other boards) are a later version, please check with the Service Center for updated diagrams (if required).

Merom CPU-2

Sheet 3 of 38
Merom CPU-2

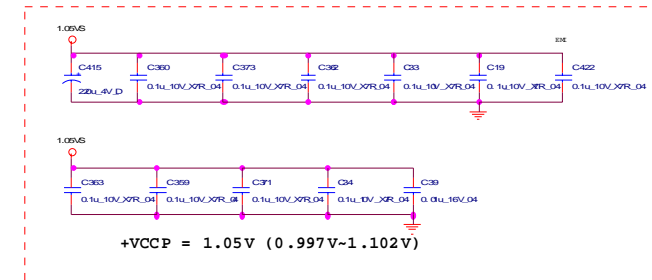
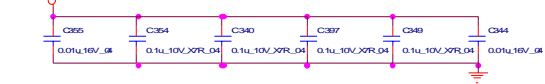
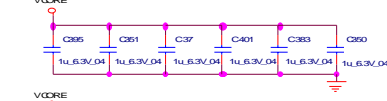
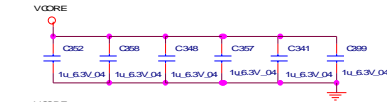
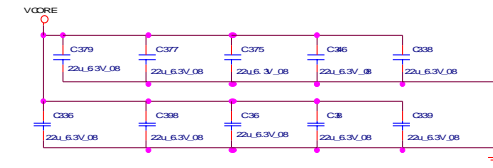
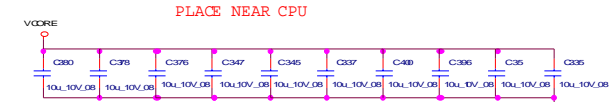
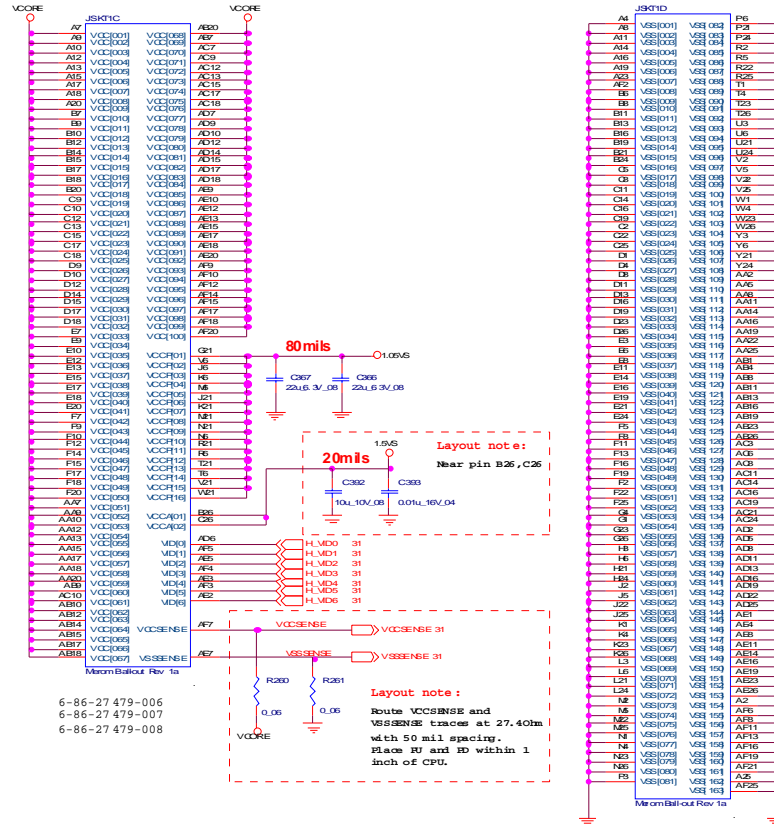

GM965 Crestline 1/5

Layout Notice:
0.1uF should be placed 100mils or less from GMCH pin.

Layout Notice:
10 mils wide, 20 mils spacing

1.05VS
R300 549 1% 0.04 MCH_HSCOMP#
R301 549 1% 0.04 MCH_HSCOMP#
R303 249 1% 0.04 MCH_HSCOMP#

Layout Notice:
MCH_HSWING a 10 mils traces and 20 mils spacing

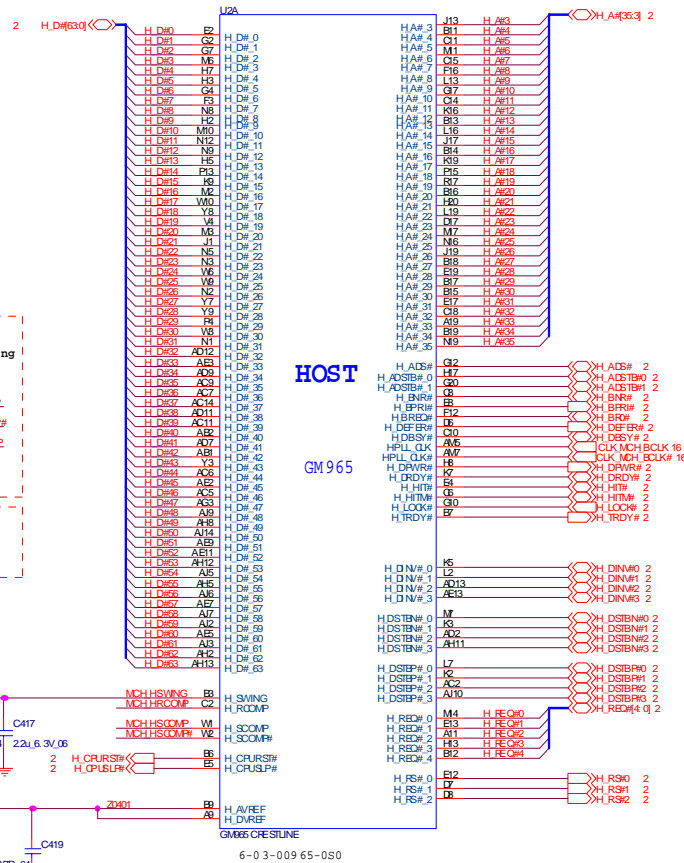
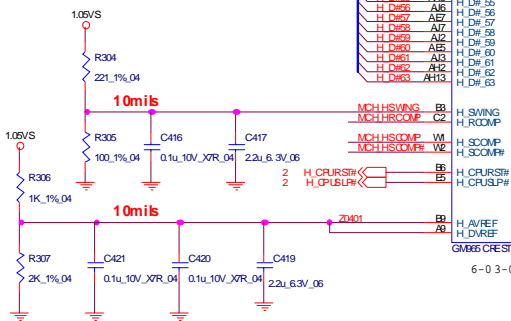

BSEL2	BSEL1	BSEID	Host Clock Frequency	
0	0	1	133 MHz	533 MHz
0	1	0	200 MHz	800 MHz

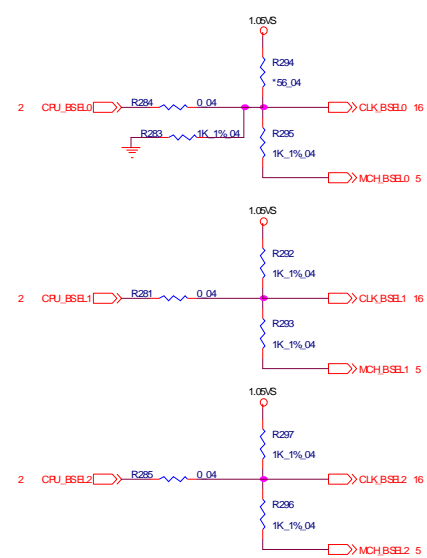

2, 3, 5, 7, 8, 12, 15, 28 1.05V/S

Sheet 4 of 38
GM965 Crestline 1/5

B.Schematic Diagrams

GM965 Crestline 4/5

Sheet 7 of 38
GM965 Crestline 4/5

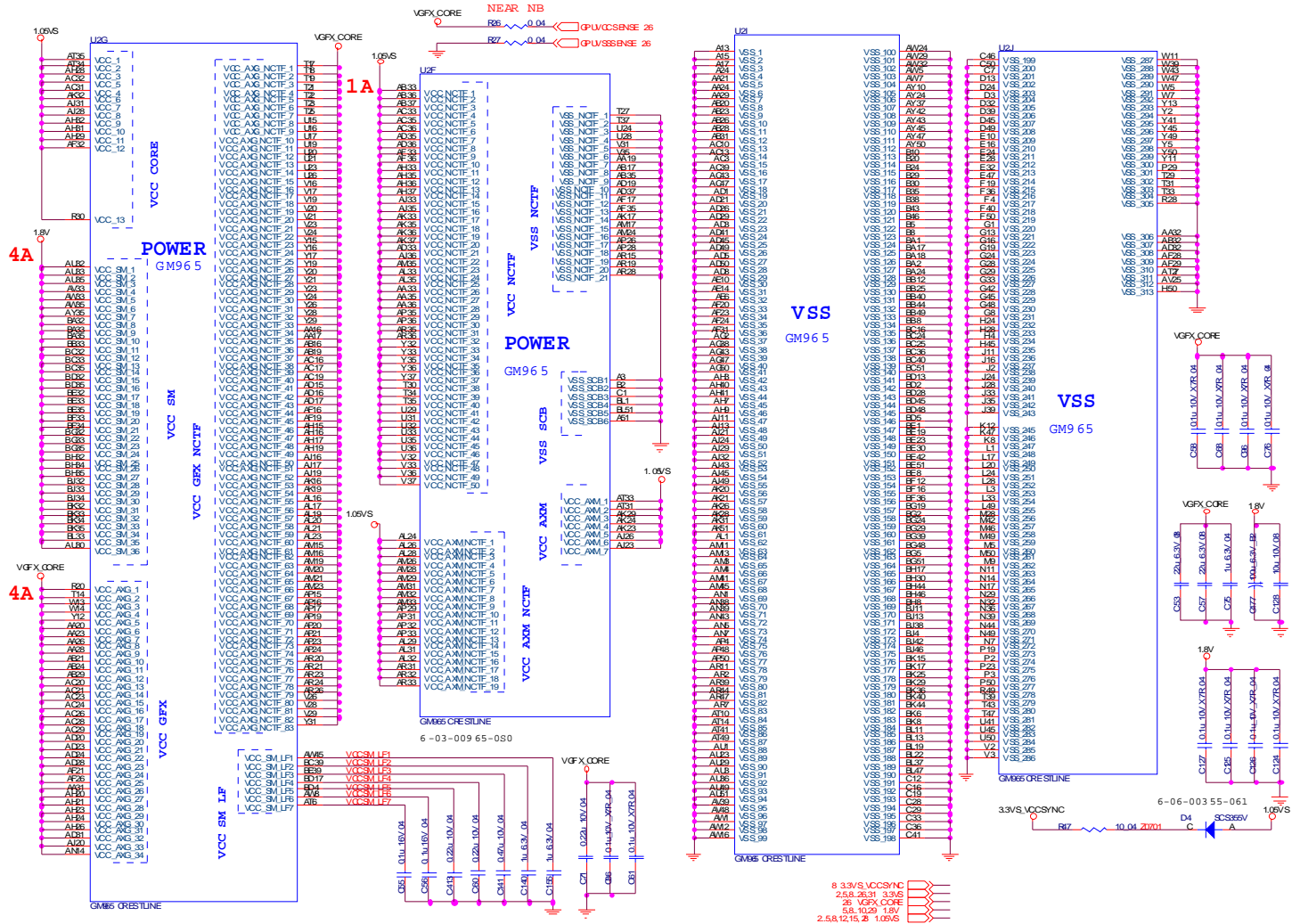

DDRII SO-DIMM 0

SO-DIMM 0

B.Schematic Diagrams

Sheet 9 of 38
DDRII SO-DIMM 1

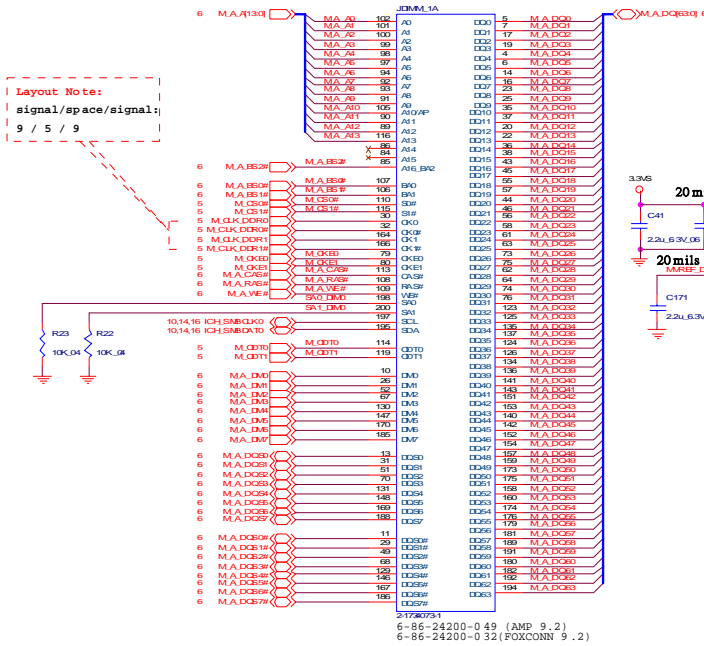

PANEL, INVERTER, CRT, FTP

Sheet 11 of 38
 PANEL, INVERTER,
 CRT, FTP

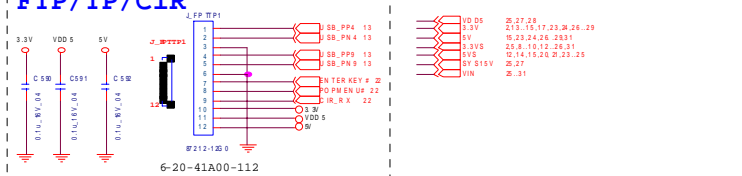
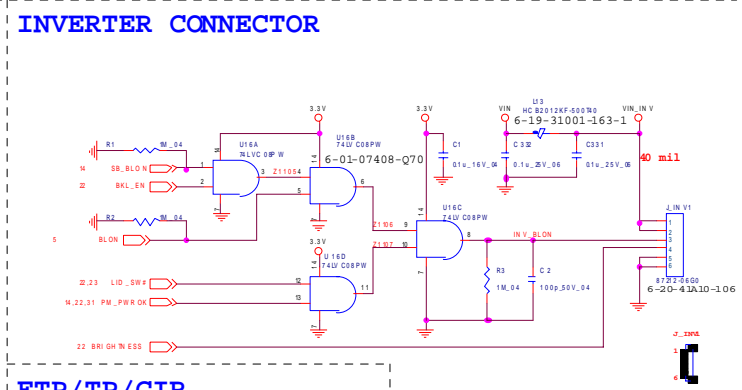
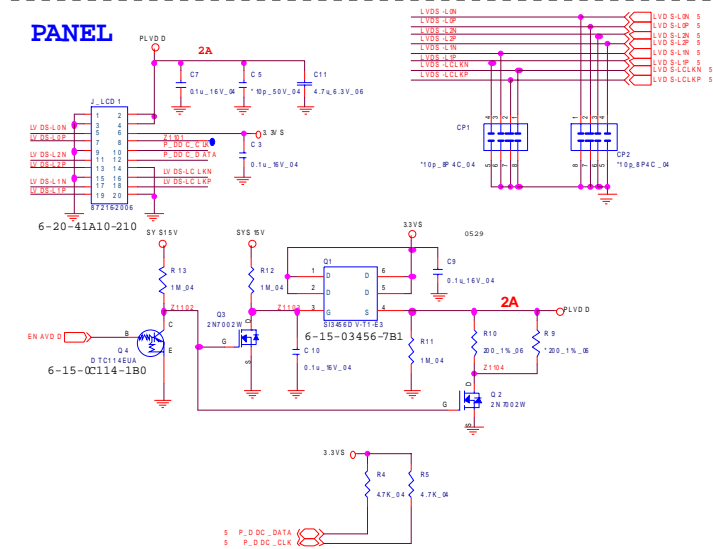
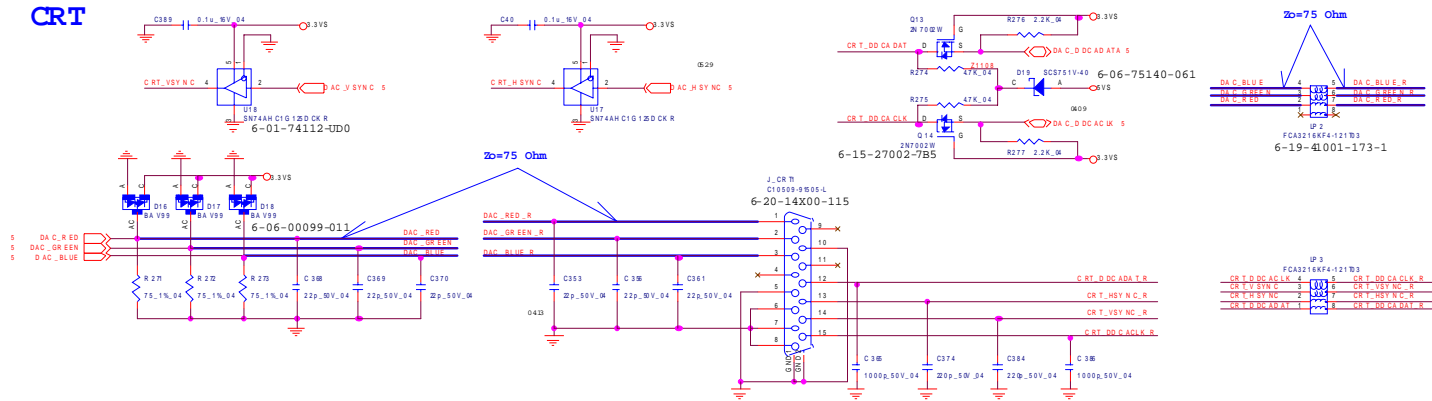

ICH8-M 1/4, SATA

B. Schematic Diagrams

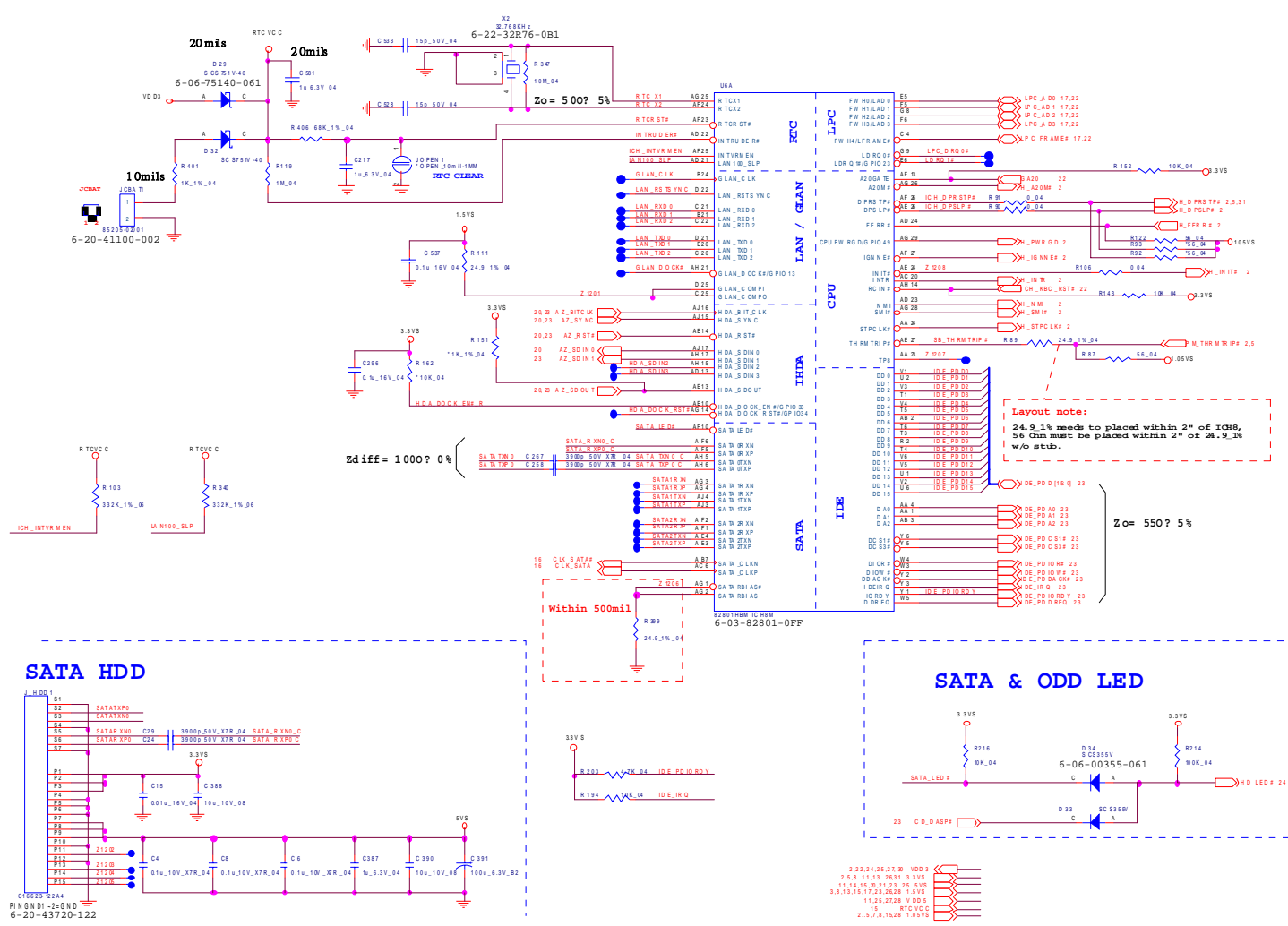

Sheet 12 of 38
ICH8-M 1/4, SATA

Layout note:
24.9.1% needs to be placed within 2" of ICH8.
56 Ohm must be placed within 2" of 24.9.1% w/o stub.

Zo = 550? 5%

ICH8-M 3/4

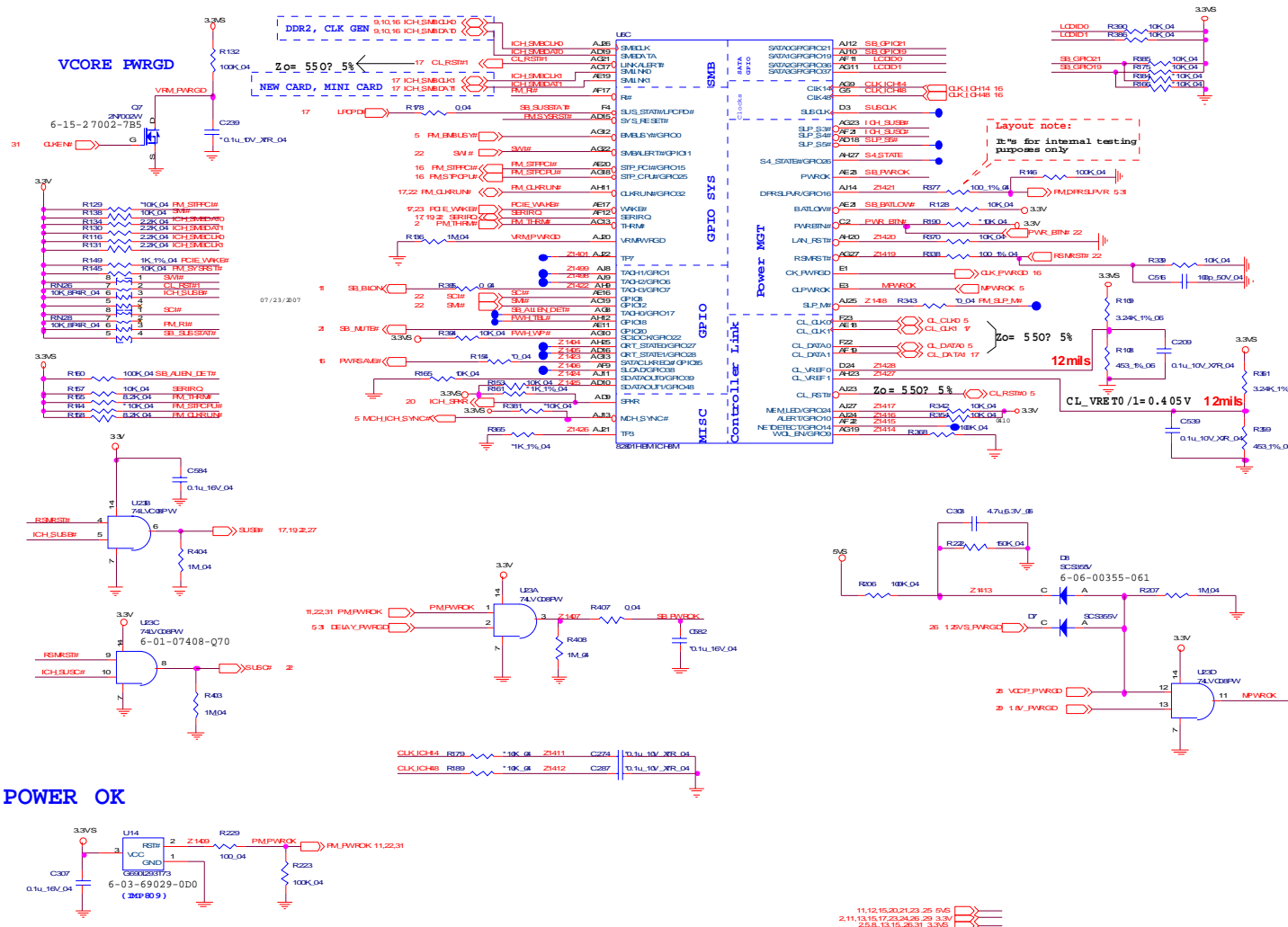

B.Schematic Diagrams

Sheet 14 of 38
ICH8-M 3/4

NEW CARD, MINI PCIE

Sheet 17 of 38
NEW CARD, MINI PCIE
PCIE

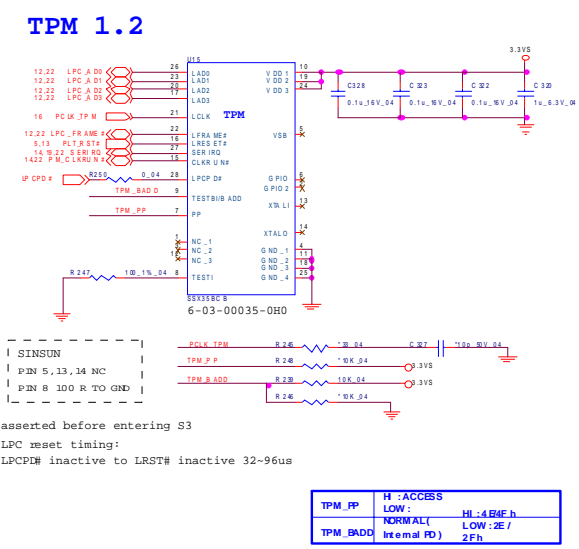
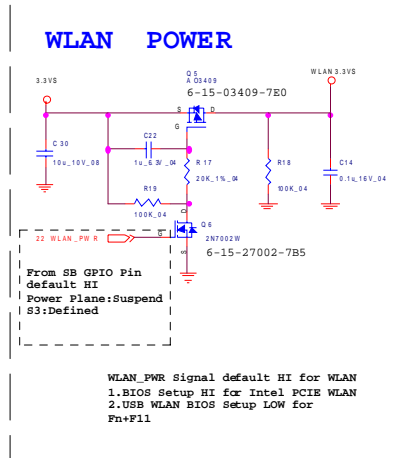
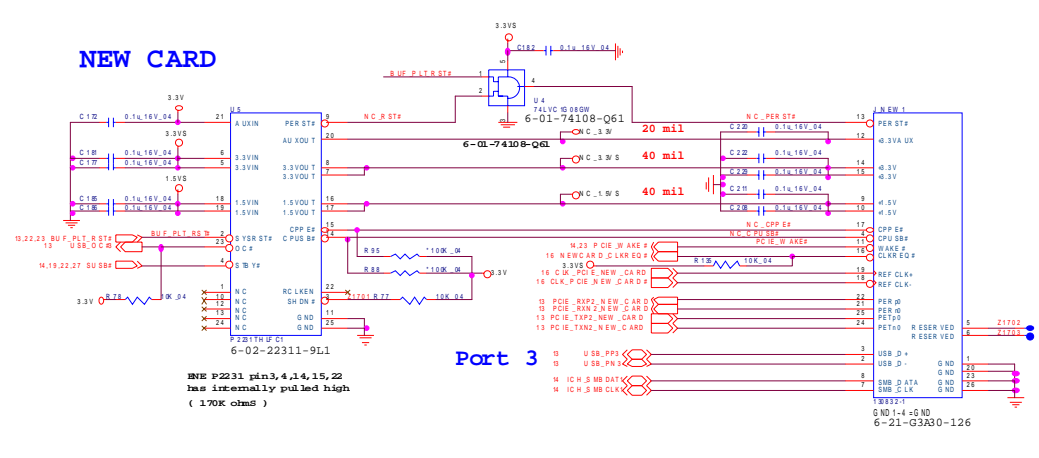

IEEE 1394 VT6311S

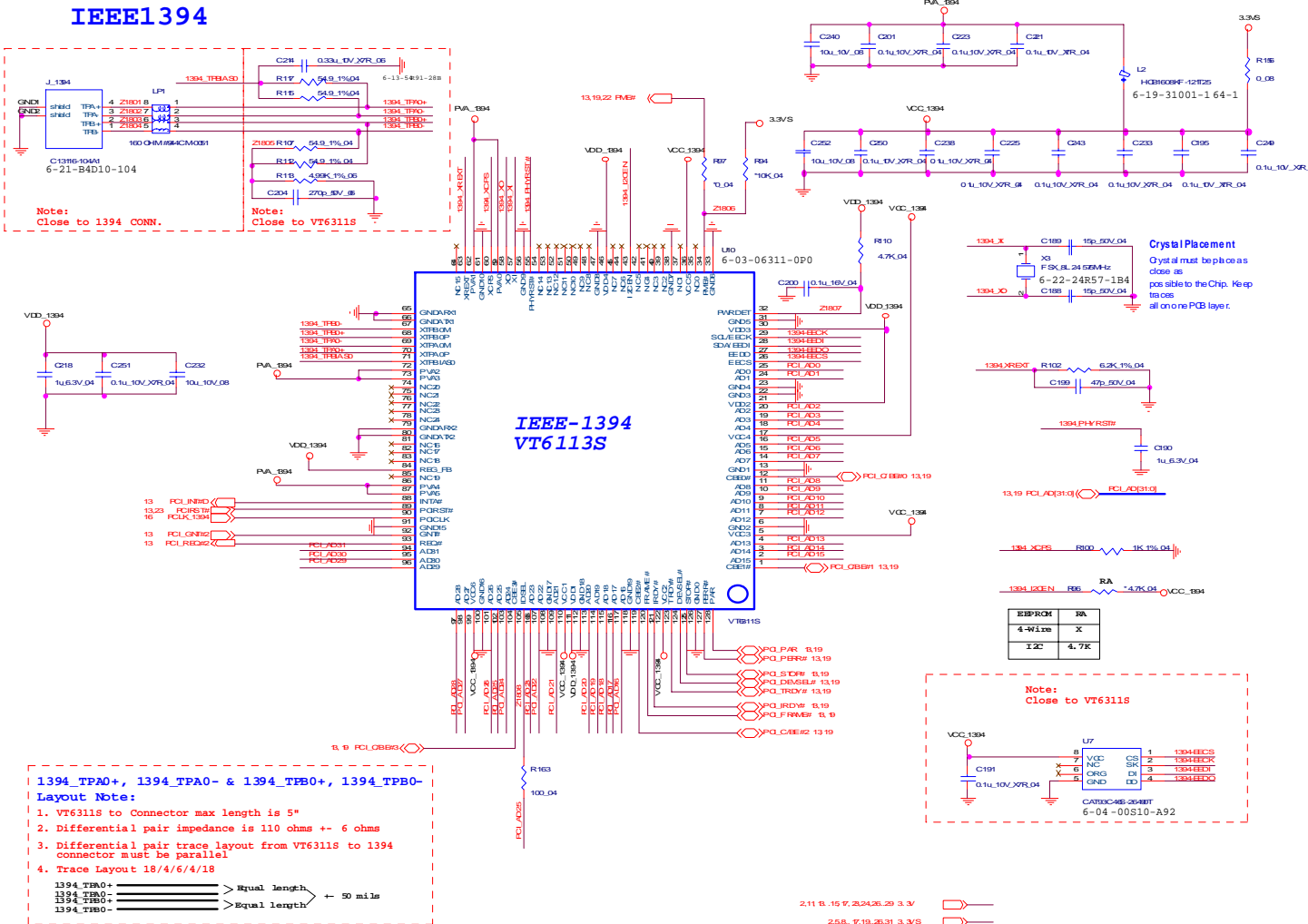

Sheet 18 of 38
IEEE 1394 VT6311S

KBC-ITE IT8512E

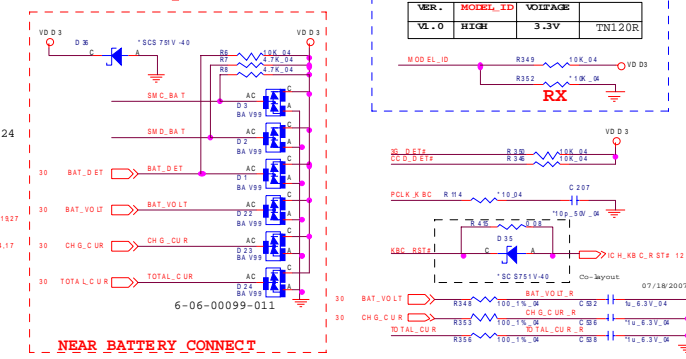
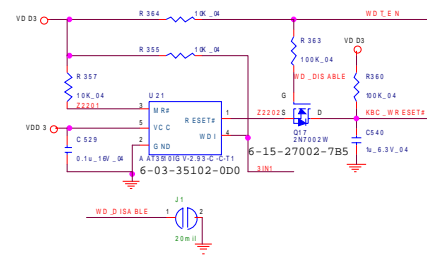
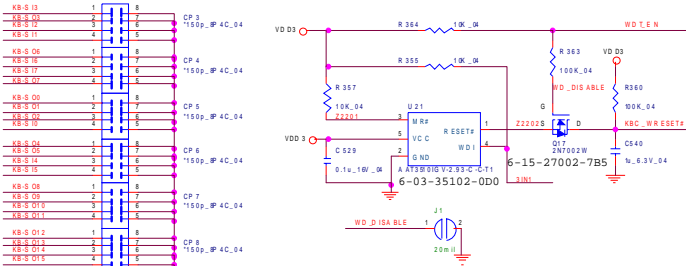
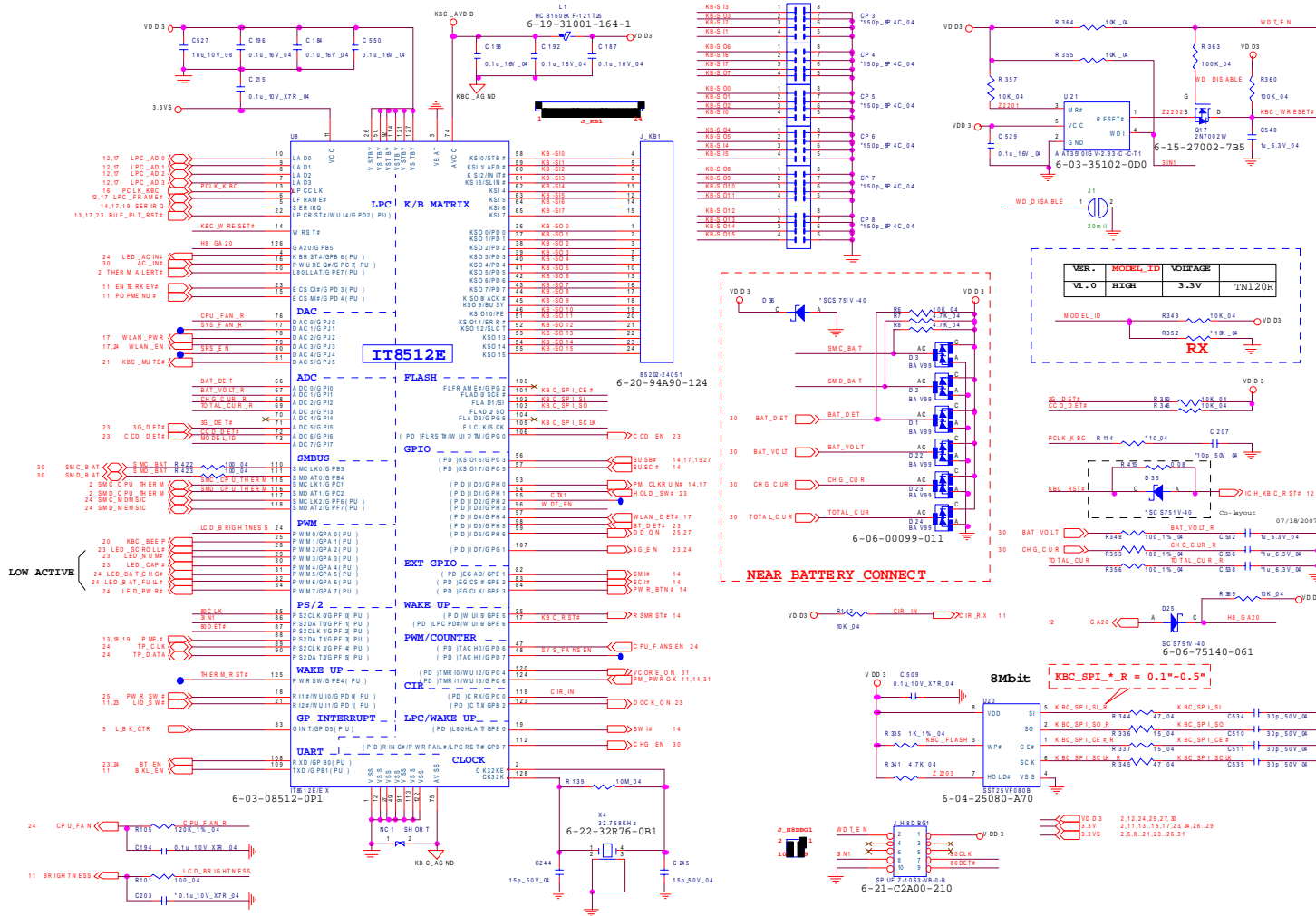

MFR.	MODEL ID	VOLTAJE
VL_0	HIGH	3.3V
		TN120R

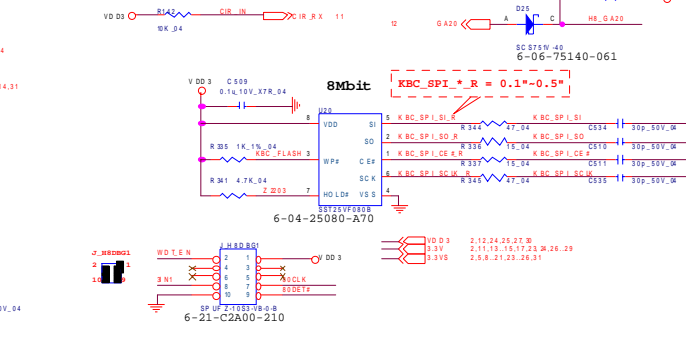

Sheet 22 of 38
KBC-ITE IT8512E

B.Schematic Diagrams

LED, FAN, CLICK, LID

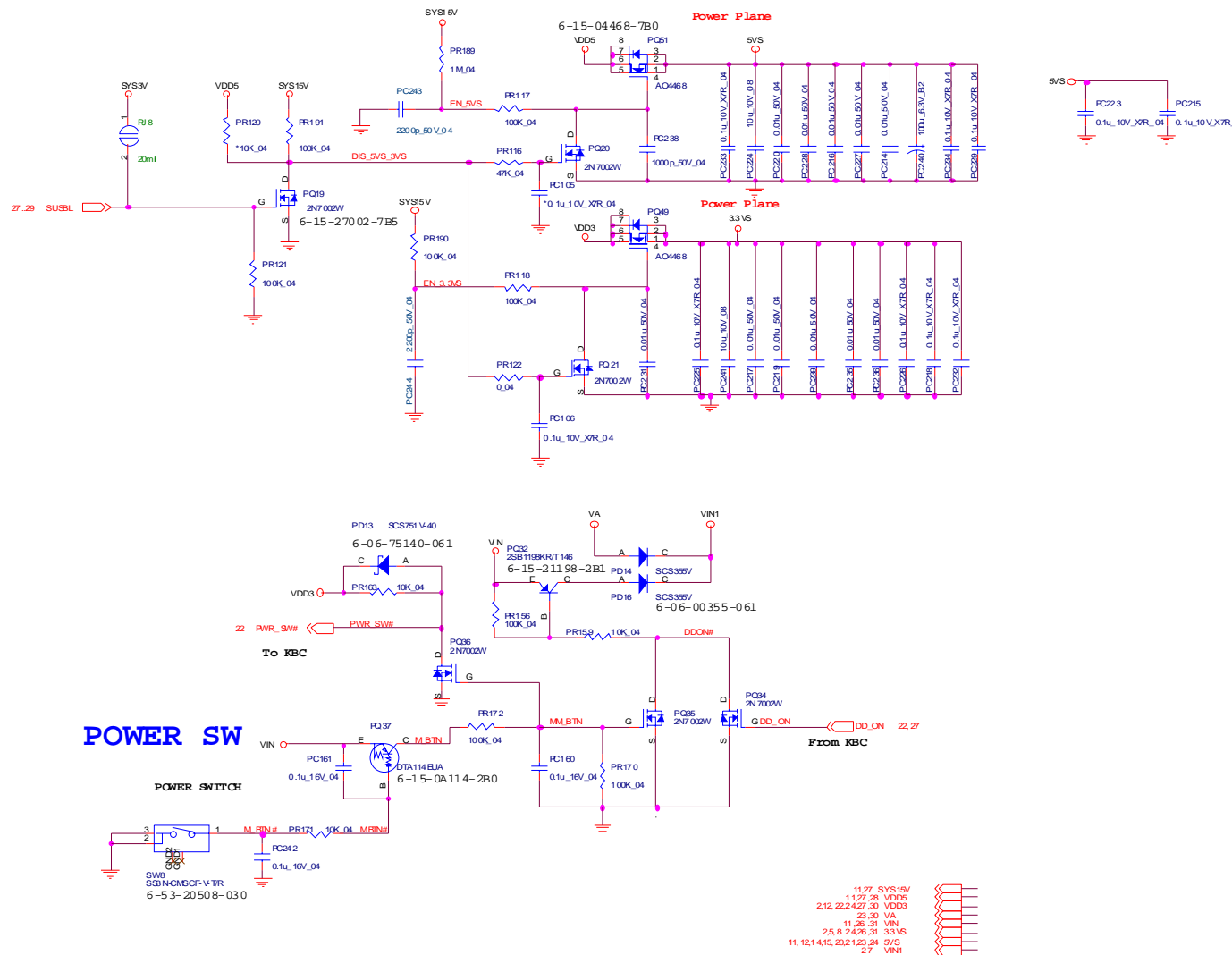

Sheet 24 of 38
LED, FAN, CLICK,
LID

Schematic Diagrams

3VS, 5VS, POWER S/W

B.Schematic Diagrams

Sheet 25 of 38
3VS, 5VS, POWER S/W

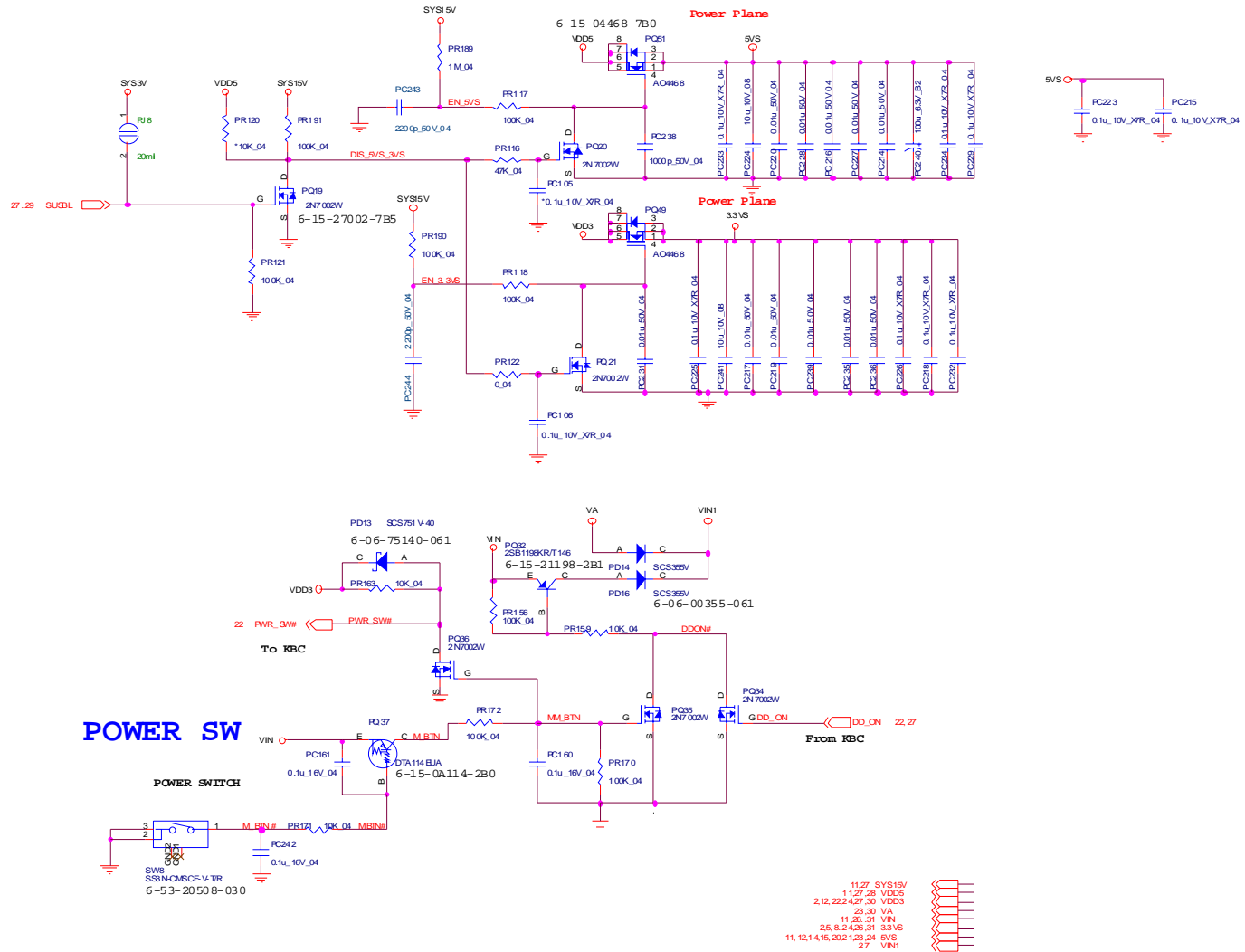

POWER 3.3V/5V

Sheet 27 of 38
POWER 3.3V/5V

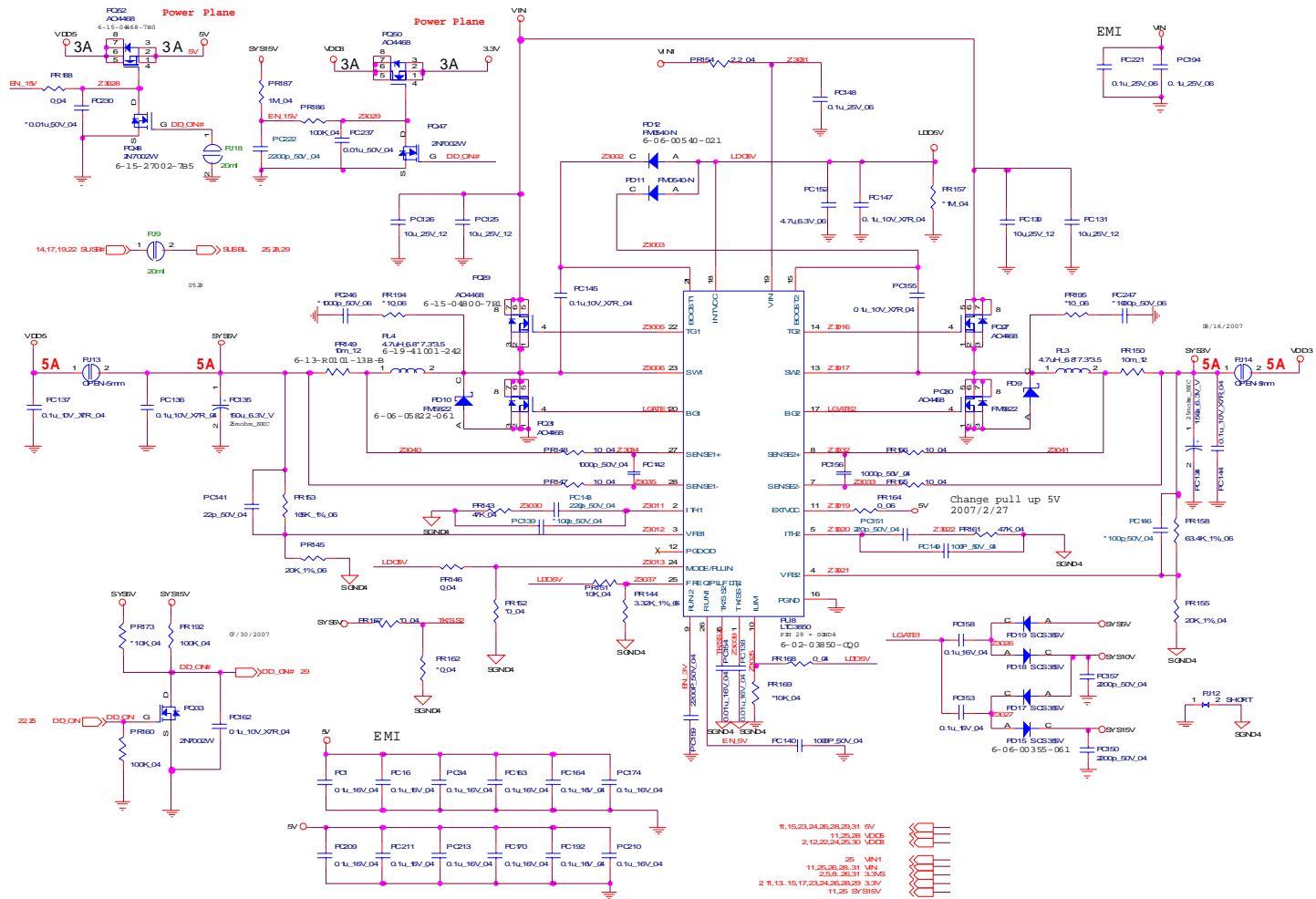

POWER 1.5VS/1.05VS

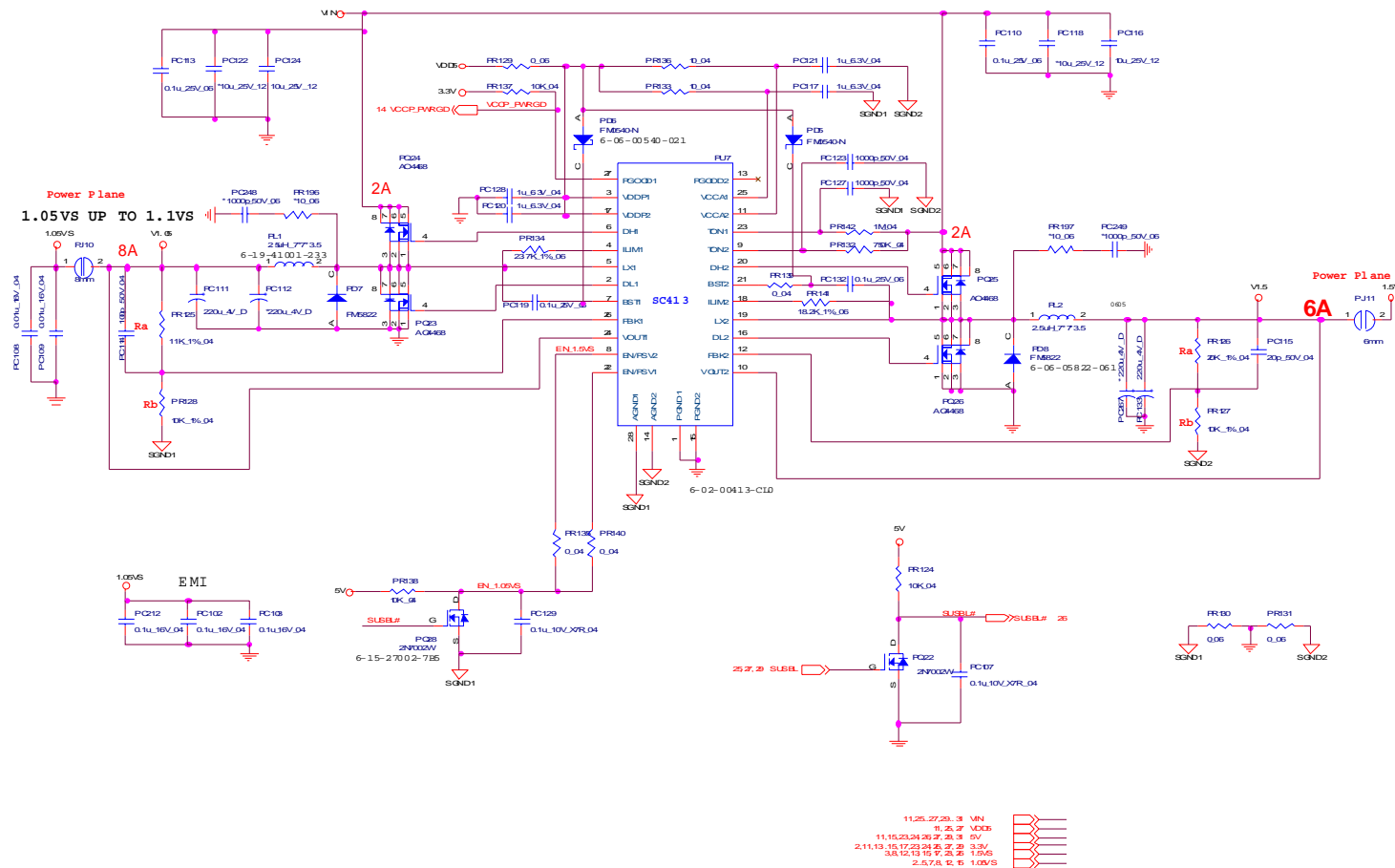

Sheet 28 of 38
POWER 1.5VS/
1.05VS

POWER 1.8V/0.9V

Sheet 29 of 38
POWER 1.8V/0.9V

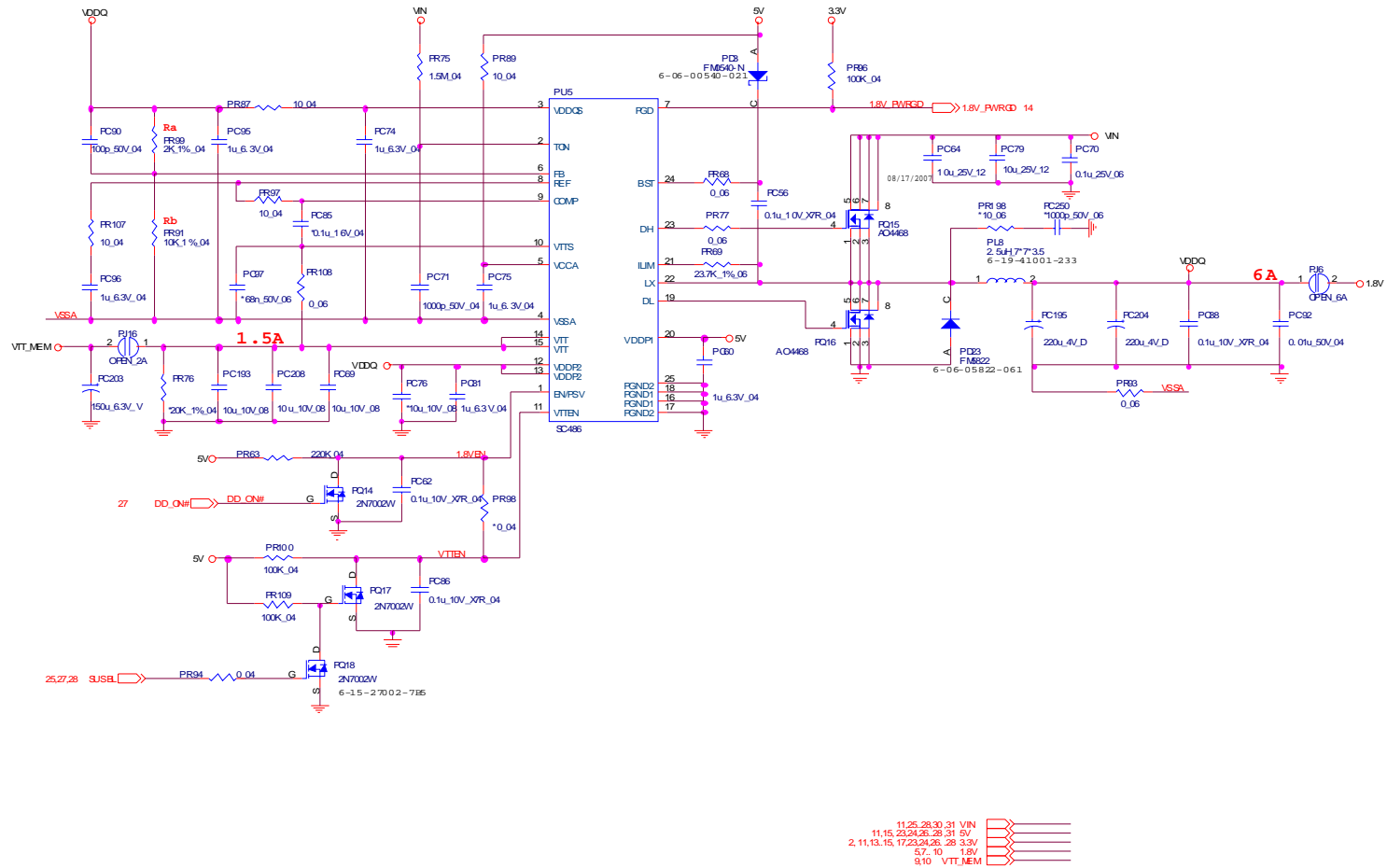

VCORE FOR MEROM CPU

VCORE FOR MEROM CPU

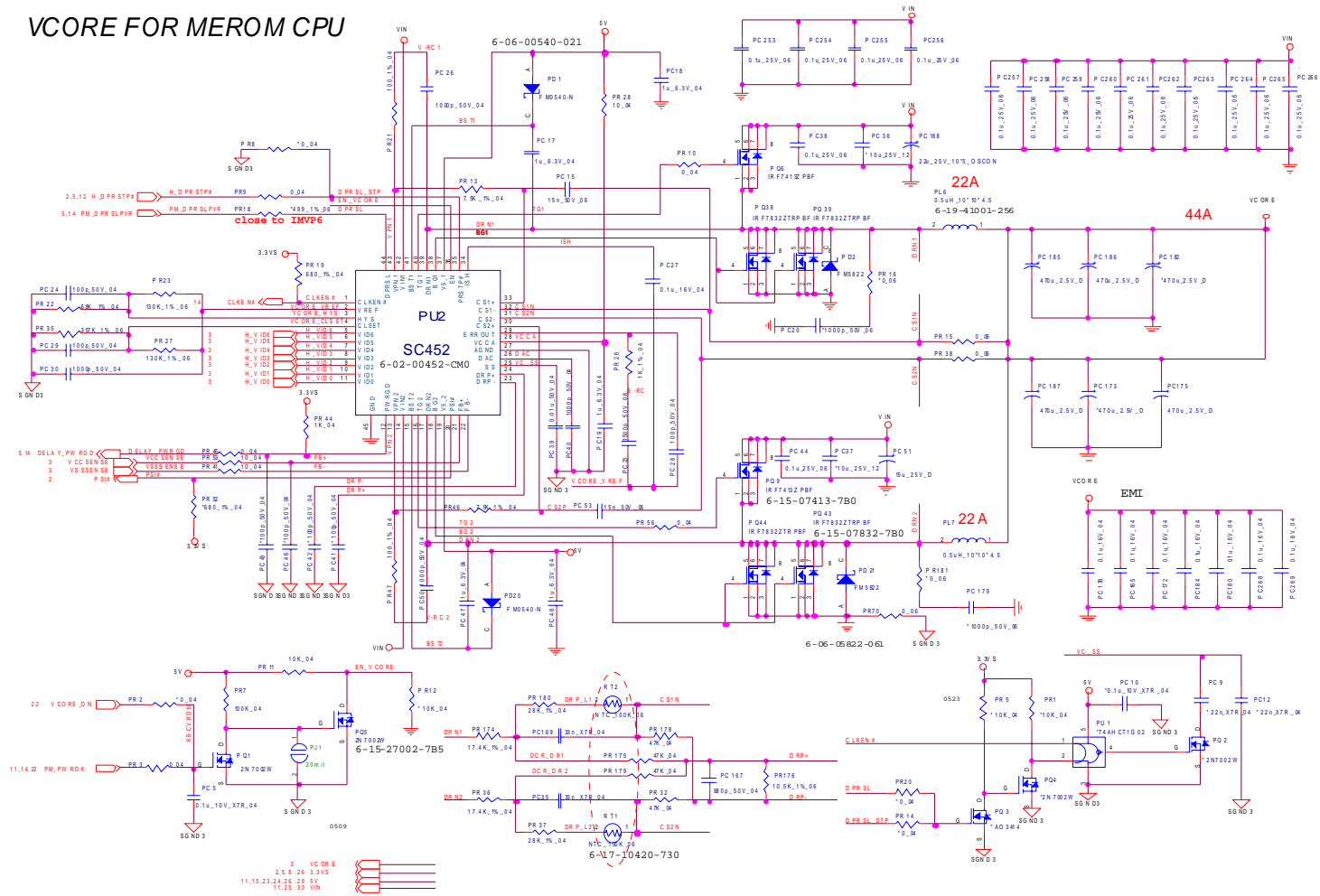

Sheet 31 of 38
VCORE FOR
MEROM CPU

B.Schematic Diagrams

Multi Board, PCIE LAN RTL8111B

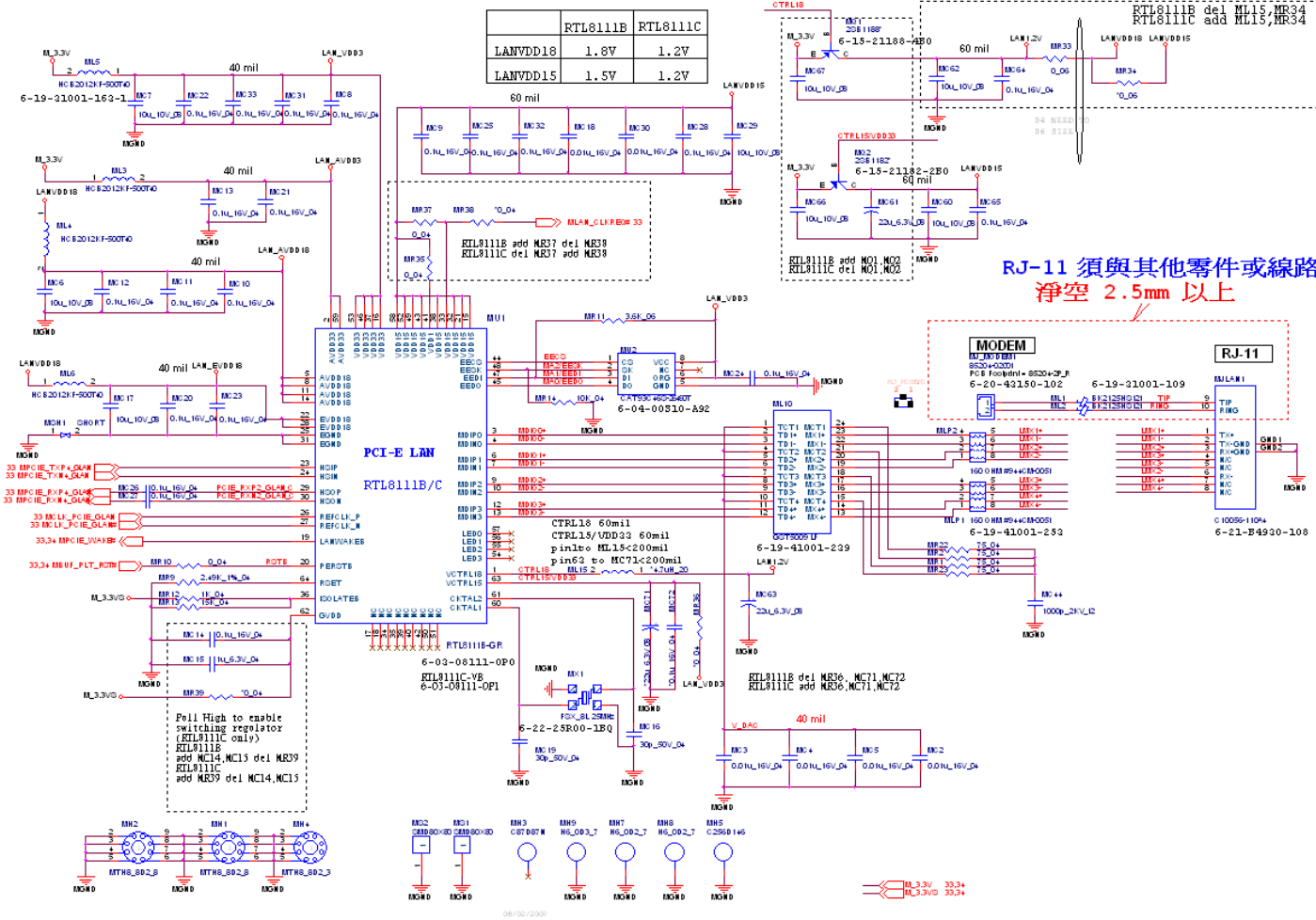

Sheet 32 of 38
Multi Board, PCIE
LAN RTL8111B

Multi Board, 3G, MDC, RJ11, LID

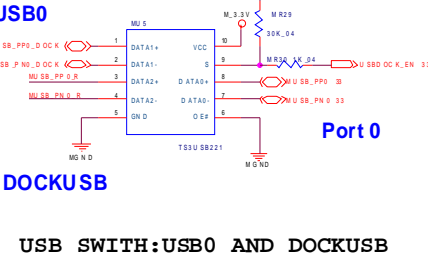
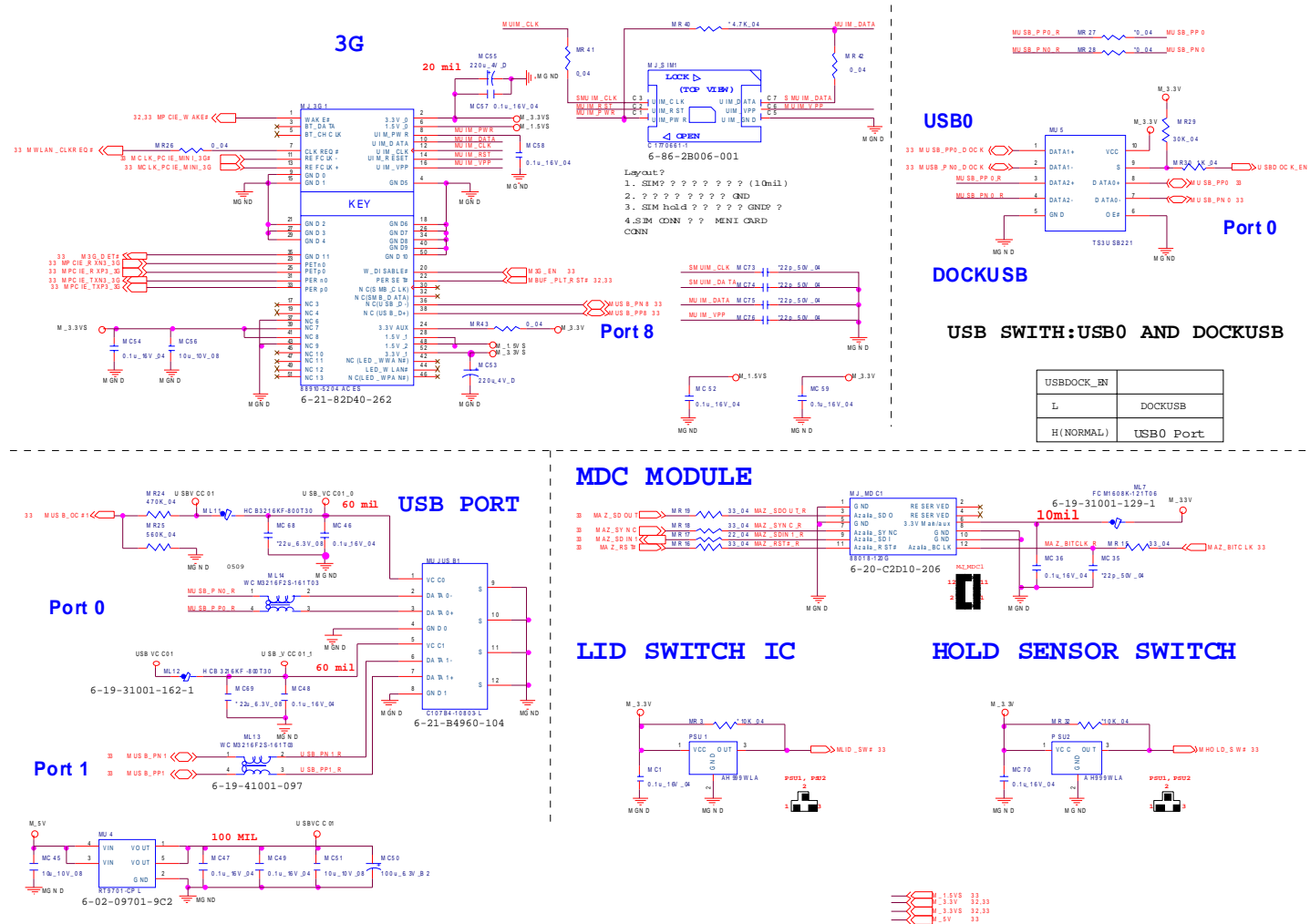

Sheet 34 of 38
Multi Board, 3G,
MDC, RJ11, LID

FPT ExBoard FINGERPRINT

FPT EXB'D FINGERPRINT

Sheet 35 of 38
FPT ExBoard
FINGERPRINT

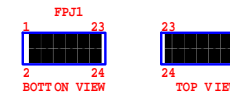
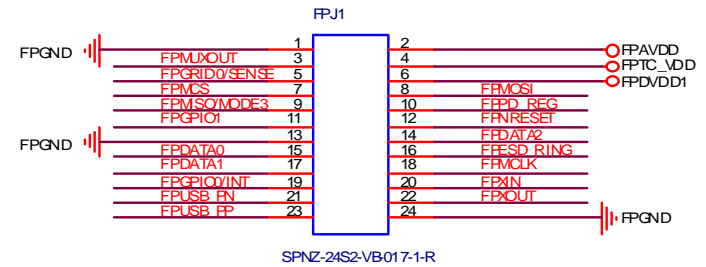
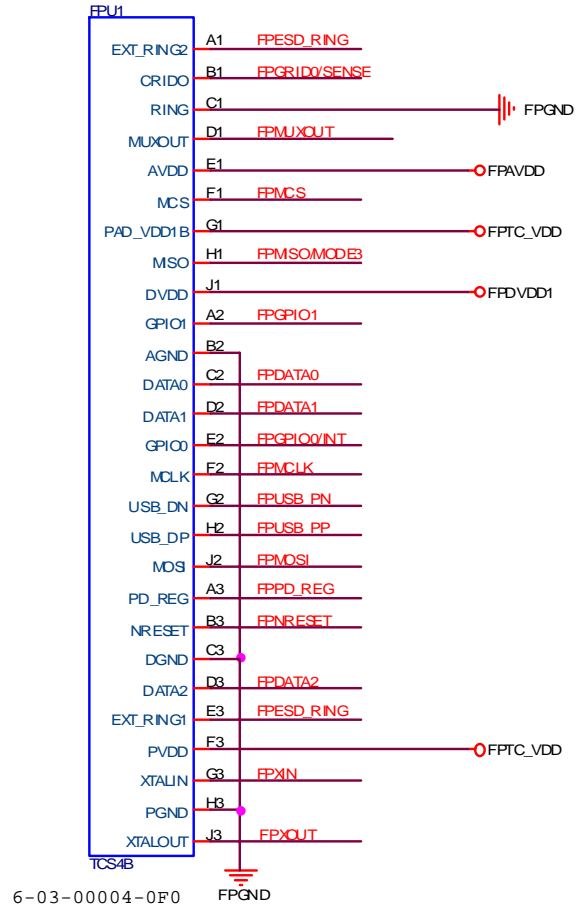

FPT MBoard TP, KEY, CIR

TOUCH PANEL

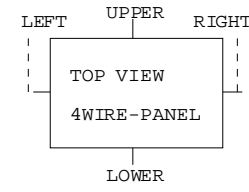
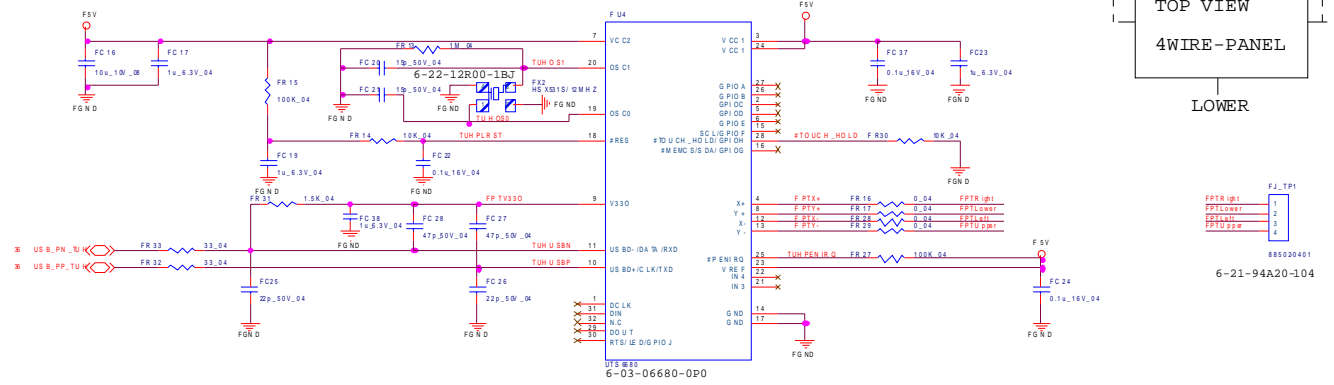

Sheet 37 of 38
FPT MBoard TP,
KEY, CIR

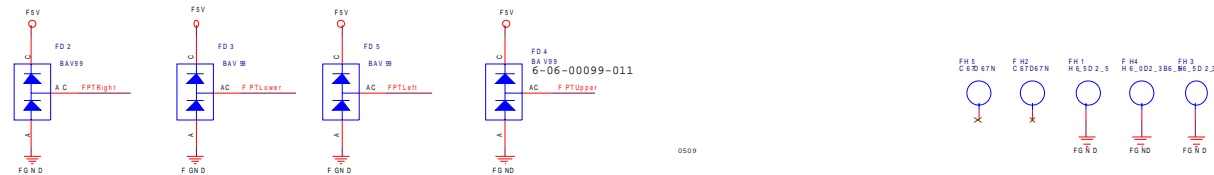

MENU KEY

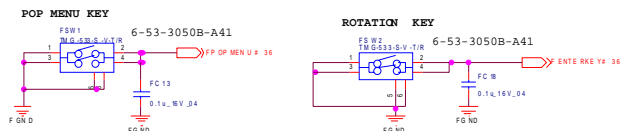

CIR

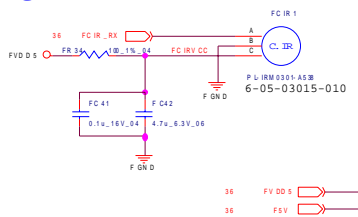

CLICK BOARD

CLICK BOARD

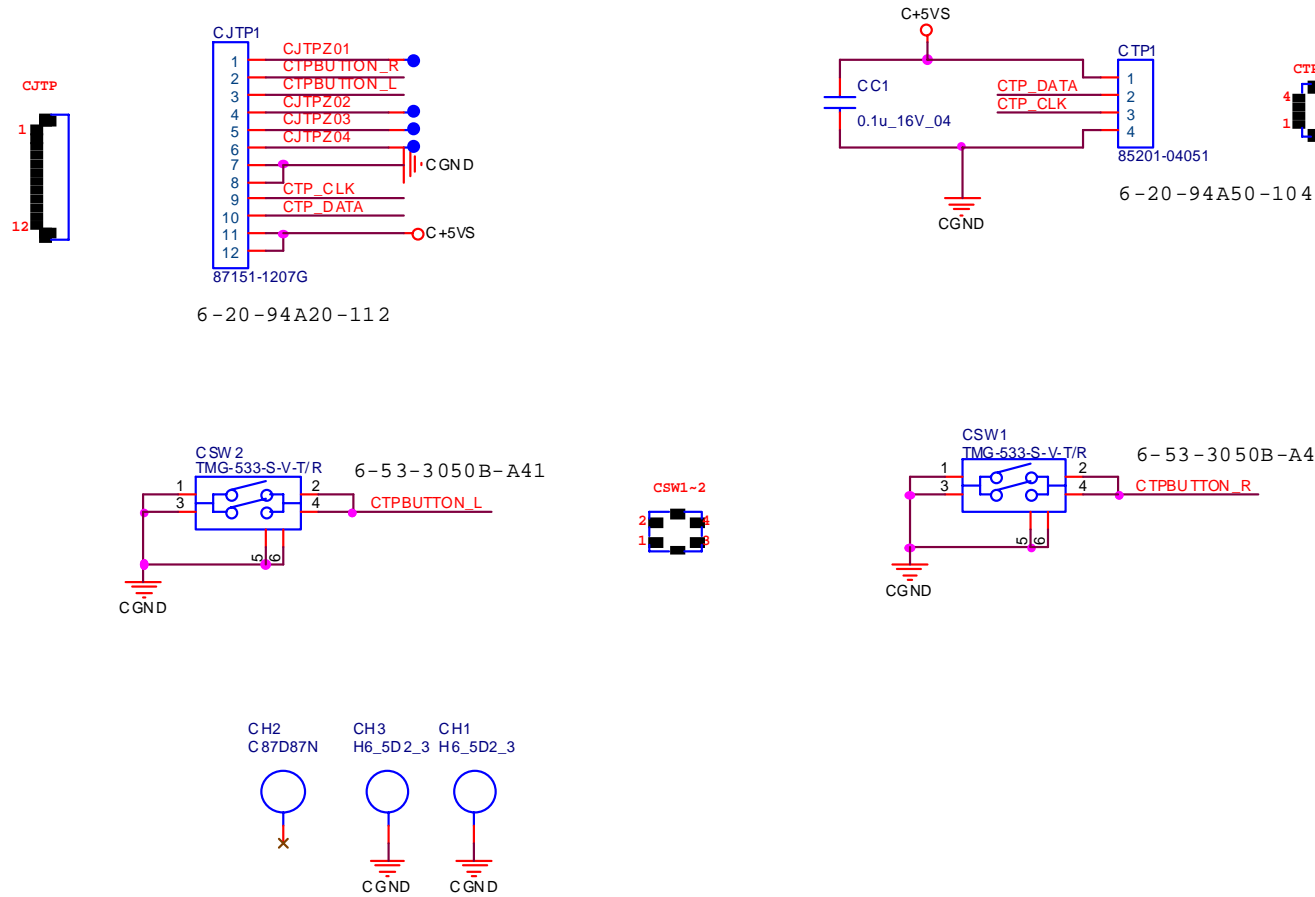

Sheet 38 of 38
CLICK BOARD

Schematic Diagrams