

SERVICE MANUAL

M980NU

notebook



Notebook Computer

M980NU

Service Manual

Notice

The company reserves the right to revise this publication or to change its contents without notice. Information contained herein is for reference only and does not constitute a commitment on the part of the manufacturer or any subsequent vendor. They assume no responsibility or liability for any errors or inaccuracies that may appear in this publication nor are they in anyway responsible for any loss or damage resulting from the use (or misuse) of this publication.

This publication and any accompanying software may not, in whole or in part, be reproduced, translated, transmitted or reduced to any machine readable form without prior consent from the vendor, manufacturer or creators of this publication, except for copies kept by the user for backup purposes.

Brand and product names mentioned in this publication may or may not be copyrights and/or registered trademarks of their respective companies. They are mentioned for identification purposes only and are not intended as an endorsement of that product or its manufacturer.

Version 1.0
June 2009

Trademarks

Intel and **Intel Core** are trademarks of Intel Corporation.

Windows[®] is a registered trademark of Microsoft Corporation.

Other brand and product names are trademarks and/or registered trademarks of their respective companies.

About this Manual

This manual is intended for service personnel who have completed sufficient training to undertake the maintenance and inspection of personal computers.

It is organized to allow you to look up basic information for servicing and/or upgrading components of the *M980NU* series notebook PC.

The following information is included:

Chapter 1, Introduction, provides general information about the location of system elements and their specifications.

Chapter 2, Disassembly, provides step-by-step instructions for disassembling parts and subsystems and how to upgrade elements of the system.

Appendix A, Part Lists

Appendix B, Schematic Diagrams

IMPORTANT SAFETY INSTRUCTIONS

Follow basic safety precautions, including those listed below, to reduce the risk of fire, electric shock and injury to persons when using any electrical equipment:

1. Do not use this product near water, for example near a bath tub, wash bowl, kitchen sink or laundry tub, in a wet basement or near a swimming pool.
2. Avoid using a telephone (other than a cordless type) during an electrical storm. There may be a remote risk of electrical shock from lightning.
3. Do not use the telephone to report a gas leak in the vicinity of the leak.
4. Use only the power cord and batteries indicated in this manual. Do not dispose of batteries in a fire. They may explode. Check with local codes for possible special disposal instructions.
5. This product is intended to be supplied by a Listed Power Unit (Full Range AC/DC Adapter – AC Input 100 - 240V, 50 - 60Hz, DC Output 20V, 11A or 19V, 11.6A).

This Computer's Optical Device is a Laser Class 1 Product

Instructions for Care and Operation

The notebook computer is quite rugged, but it can be damaged. To prevent this, follow these suggestions:

1. **Don't drop it, or expose it to shock.** If the computer falls, the case and the components could be damaged.



2. **Keep it dry, and don't overheat it.** Keep the computer and power supply away from any kind of heating element. This is an electrical appliance. If water or any other liquid gets into it, the computer could be badly damaged.

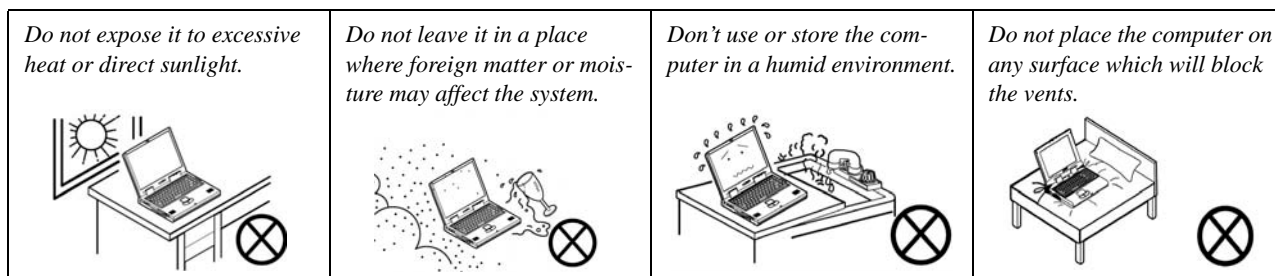

3. **Follow the proper working procedures for the computer.** Shut the computer down properly and don't forget to save your work. Remember to periodically save your data as data may be lost if the battery is depleted.

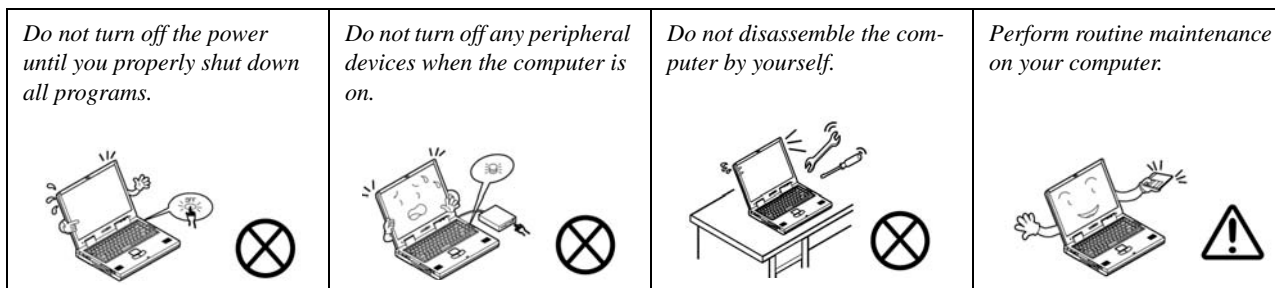

4. **Avoid interference.** Keep the computer away from high capacity transformers, electric motors, and other strong magnetic fields. These can hinder proper performance and damage your data.
5. **Take care when using peripheral devices.**

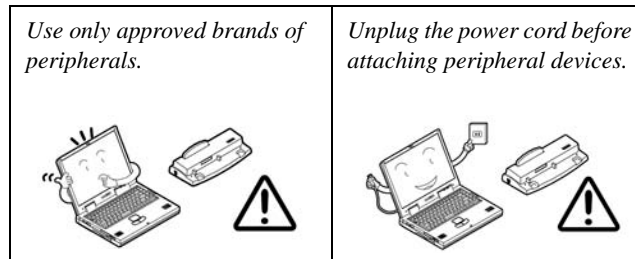

Power Safety

The computer has specific power requirements:

- Only use a power adapter approved for use with this computer.
- Your AC adapter may be designed for international travel but it still requires a steady, uninterrupted power supply. If you are unsure of your local power specifications, consult your service representative or local power company.
- The power adapter may have either a 2-prong or a 3-prong grounded plug. The third prong is an important safety feature; do not defeat its purpose. If you do not have access to a compatible outlet, have a qualified electrician install one.
- When you want to unplug the power cord, be sure to disconnect it by the plug head, not by its wire.
- Make sure the socket and any extension cord(s) you use can support the total current load of all the connected devices.
- Before cleaning the computer, make sure it is disconnected from any external power supplies.

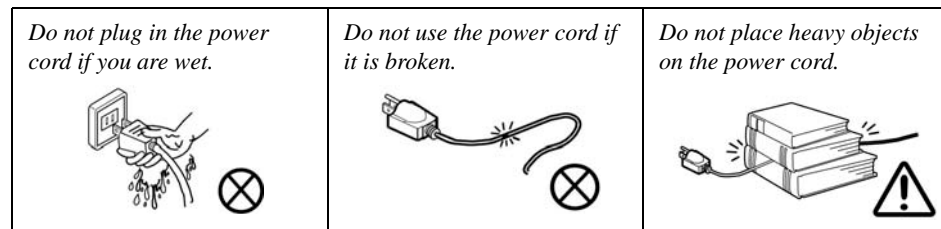

Power Safety Warning

Before you undertake any upgrade procedures, make sure that you have turned off the power, and disconnected all peripherals and cables (including telephone lines). It is advisable to also remove your battery in order to prevent accidentally turning the machine on.

Battery Precautions

- Only use batteries designed for this computer. The wrong battery type may explode, leak or damage the computer.
- Do not continue to use a battery that has been dropped, or that appears damaged (e.g. bent or twisted) in any way. Even if the computer continues to work with a damaged battery in place, it may cause circuit damage, which may possibly result in fire.
- Recharge the batteries using the notebook's system. Incorrect recharging may make the battery explode.
- Do not try to repair a battery pack. Refer any battery pack repair or replacement to your service representative or qualified service personnel.
- Keep children away from, and promptly dispose of a damaged battery. Always dispose of batteries carefully. Batteries may explode or leak if exposed to fire, or improperly handled or discarded.
- Keep the battery away from metal appliances.
- Affix tape to the battery contacts before disposing of the battery.
- Do not touch the battery contacts with your hands or metal objects.

Battery Guidelines

The following can also apply to any backup batteries you may have.

- If you do not use the battery for an extended period, then remove the battery from the computer for storage.
- Before removing the battery for storage charge it to 60% - 70%.
- Check stored batteries at least every 3 months and charge them to 60% - 70%.



Battery Disposal

The product that you have purchased contains a rechargeable battery. The battery is recyclable. At the end of its useful life, under various state and local laws, it may be illegal to dispose of this battery into the municipal waste stream. Check with your local solid waste officials for details in your area for recycling options or proper disposal.

Caution

Danger of explosion if battery is incorrectly replaced. Replace only with the same or equivalent type recommended by the manufacturer. Discard used battery according to the manufacturer's instructions.

Battery Level

Click the battery icon  in the taskbar to see the current battery level and charge status. A battery that drops below a level of 10% will not allow the computer to boot up. Make sure that any battery that drops below 10% is recharged within one week.

Related Documents

You may also need to consult the following manual for additional information:

User's Manual on CD

This describes the notebook PC's features and the procedures for operating the computer and its ROM-based setup program. It also describes the installation and operation of the utility programs provided with the notebook PC.

Contents

Introduction1-1

Overview	1-1
System Specifications	1-2
External Locator - Top View with LCD Panel Open	1-5
External Locator - Front & Right side Views	1-6
External Locator - Left Side & Rear View	1-7
External Locator - Bottom View	1-8
Mainboard Overview - Top (Key Parts)	1-9
Mainboard Overview - Bottom (Key Parts)	1-10
Mainboard Overview - Top (Connectors)	1-11
Mainboard Overview - Bottom (Connectors)	1-12

Disassembly2-1

Overview	2-1
Maintenance Tools	2-2
Connections	2-2
Maintenance Precautions	2-3
Disassembly Steps	2-4
Removing the Battery	2-5
Removing the Optical (CD/DVD) Device	2-6
Removing the Hard Disk Drive	2-7
Removing the System Memory (RAM)	2-9
Removing the VGA Card	2-11
Installing the VGA Card	2-13
Removing the TV Tuner Card	2-14

Part ListsA-1

Part List Illustration Location	A-2
Top with Fingerprint	A-3
Top without Fingerprint	A-4
Bottom	A-5

LCD	A-6
Mainboard	A-7
Blu-Ray Combo	A-8
DVD Super Multi	A-9

Schematic Diagrams.....B-1

System Block Diagram	B-2
PENRYN 1/2	B-3
PENRYN3 2/2	B-4
MCP79 FSBI	B-5
MCP79 MEM CTRL (1)	B-6
MCP79 MEM CTRL (2)	B-7
MCP79 PCI-E	B-8
MCP79 LAN, Panel	B-9
MCP79 PCI, LPC	B-10
MCP79 SATA, USB	B-11
MCP79 HDA, Misc	B-12
MCP79 Power	B-13
MCP79 GND, RMGT PWR, PWRGD	B-14
DDR3 SO-DIMM_0	B-15
DDR SO-DIMM_1	B-16
Panel, Inverter, TPM	B-17
HDMI, Fan Control	B-18
CRT, DVI	B-19
ODD, CCD, BT, USB 2.0	B-20
KBC ITE IT8512-J	B-21
PHY RTL8211CL	B-22
Codec, Subwoofer, DMIC	B-23
Audio AMP	B-24
HDMI Switch	B-25
New Card, Mini Card	B-26

Preface

Card Reader, IEEE 1394	B-27
MXM 3.0 Master	B-28
MXM 3.0 Slave	B-29
MB to Small B'd Connector A	B-30
MB to Small B'd Connector B	B-31
Power System	B-32
Power VCore	B-33
PWR 1.05V, Screw Hole	B-34
Power 1.5V/0.75V	B-35
Power 1.0VS	B-36
Power 3.3V/5V	B-37
Power Charger, DC-In	B-38
Single HDD Board	B-39
Dual HDD Board	B-40
Audio Board	B-41
Power Button Board	B-42
Click & FP Board	B-43
Logo LED Board	B-44
Game Key Board	B-45
TouchPad LED Board	B-46
Front R Side LED Board	B-47
Front L Side LED Board	B-48
Back L Side LED Board	B-49
Touch Sensor Board A	B-50
Touch Sensor Board B	B-51
CIR Board	B-52
Finger Board	B-53
PWR on SEQ Diagram	B-54

Chapter 1: Introduction

Overview

This manual covers the information you need to service or upgrade the *M980NU* series notebook computer. Information about operating the computer (e.g. getting started, and the *Setup* utility) is in the *User's Manual*. Information about drivers (e.g. VGA & audio) is also found in *User's Manual*. That manual is shipped with the computer.

Operating systems (e.g. *Windows XP*, *Windows Vista*, etc.) have their own manuals as do application software (e.g. word processing and database programs). If you have questions about those programs, you should consult those manuals.

The *M980NU* series notebook is designed to be upgradeable. See *“Disassembly” on page 2 - 1* for a detailed description of the upgrade procedures for each specific component. Please note the warning and safety information indicated by the “” symbol.

The balance of this chapter reviews the computer's technical specifications and features.

System Specifications

Processor
<p>Intel® Core™ 2 Quad Processor - (478-pin) Micro-FC-PGA Package, 45nm (45 Nanometer) Process Technology: QX93000 - 2.53 GHz, 12MB On-die L2 Cache & 1066MHz FSB (45W) X9100 - 2.53GHz, 6MB On-die L2 Cache & 1066MHz FSB (44W) Q9000 - 2.0GHz, 6MB On-die L2 Cache & 1066MHz FSB (45W) Q9100 - 2.26GHz, 12MB On-die L2 Cache & 1066MHz FSB (45W)</p> <p>Intel® Core™ 2 Duo Processor - (478-pin) Micro-FC-PGA Package, 45nm (45 Nanometer) Process Technology: T9400 - 2.53 GHz, 6MB On-die L2 Cache & 1066MHz FSB (35W) T9600 - 2.80 GHz, 6MB On-die L2 Cache & 1066MHz FSB (35W) T9800 - 2.93 GHz, 6MB On-die L2 Cache & 1066MHz FSB (35W)</p> <p>Intel® Core™ 2 Duo Processor - (478-pin) Micro-FC-PGA Package, 45nm (45 Nanometer) Process Technology: P9500 - 2.66 GHz, 6MB On-die L2 Cache & 1066MHz FSB (25W) P9600 - 2.53 GHz, 6MB On-die L2 Cache & 1066MHz FSB (25W) P8600 - 2.66 GHz, 3MB On-die L2 Cache & 1066MHz FSB (25W) P8700 - 2.53 GHz, 3MB On-die L2 Cache & 1066MHz FSB (25W)</p>
Core Logic
MCP79 SLI Chipset
Display
18.4" Full HD (1920 * 1080) TFT LCD
Memory
<p>Two 64-bit wide DDRIII (DDR3) data channels Two 204 Pin SO-DIMM Sockets Supporting DDRIII (DDR3) 1066MHz/1333MHz Memory Modules Memory Expandable up to 4GB</p>

Video Adapter
<p>nVIDIA® GeForce GTX 280M SLI PCIe Video Card 1GB GDDR3 Video RAM On Board Supports PCIe * 8 (SLI - 2 * PCIe * 8) Supports Microsoft DirectX® 10.0 Supports HDCP</p>
BIOS
<p>One 8Mb Flash ROM Phoenix™ BIOS</p>
Storage
<p>Up to three (Option) Changeable 2.5" 9.5 mm (h) SATA (Serial) Hard Disk Drives supporting RAID level 0/1 One 12.7 mm Super Multi/Blu-Ray Combo/Writer SATA Optical Device Drive (Option)</p>
Keyboard & Pointing Device
<p>Full Size Winkey Keyboard with Numeric Keypad Built-In TouchPad (Scroll Functionality Included) Eight Touch Sensor Instant Keys (Color, CCD, Bluetooth, WLAN, Internet, Silent Mode, Sound Effect, Mute) Eight Gaming Keys G1 ~ G8</p>
Card Reader
<p>Embedded 7-in-1 Card Reader (MS/ MS Pro/ SD/ Mini SD/ MMC/ RS MMC/ MS Duo) Note: MS Duo/ Mini SD/ RS MMC Cards require a PC adapter</p>

Interface
Four USB 2.0 Ports One eSATA Port One DVI-Out Port (with CRT out) One HDMI (High-Definition Multimedia Interface) Port with Audio Output (with HDCP Support) One Headphone/Speaker-Out Jack One Microphone-In Jack One Line-In Jack One S/PDIF Out Jack One RJ-45 LAN Jack One Mini-IEEE1394a Port One DC-In Jack One Consumer Infrared Port for TV Tuner Remote Controller CATV Jack (for TV Tuner)
Slots
One ExpressCard/34/54 Slot Two Mini Card Slots: Slot 1 for PCIe WLAN Module Slot 2 for USB TV Tuner Module
Audio
High Definition Audio3D Stereo Enhanced Sound System S/PDIF Digital Output Built-In Microphone 5 * Built-In Speakers (2W/ 1.5W, 4Ω) One Sub Woofer (2W, 4Ω, Dolby Surround Supported
Security
Security (Kensington® Type) Lock Slot BIOS Password Fingerprint Reader Module (Factory Option) Trusted Platform Module V1.2 (Factory Option)

Communication
Built-In Giga Base-TX Ethernet LAN Bluetooth 2.1 + EDR (Enhanced Data Rate) Module (Factory Option) Intel® WiFi Link 5300 Series (3*3 - 802.11a/g/n) Wireless LAN PCIe interface Mini-Card Module (Option) Intel® WiFi Link 5100 Series (1*2 - 802.11a/g/n) Wireless LAN PCIe interface Mini-Card Module (Option) 3rd Party 802.11b/g Wireless LAN PCIe interface Mini-Card Module (Option) 2.0M or 3.0M Pixel PC Camera Module with USB interface (Factory Option)
Operating System
Windows Vista Home Premium/ Business/ Enterprise/ Ultimate Note that the TV Tuner module (factory) option in Windows Vista is supported by the Windows Media Center software which comes built-in to the Windows Vista Home Premium and Ultimate Editions only .
Power Management
Supports Wake on LAN Supports Wake on USB
Power
Full Range AC/DC Adapter – AC in 100 - 240V, 50 - 60Hz DC Output 19V, 11.6A or 19V, 12.2A (220 Watts) Easy Changeable Polima Smart Lithium-Ion 4650mAH Main Battery
Physical Dimensions & Weight
439mm (w) * 299mm (d) * 44mm (h) Around 4.9kg with Battery and ODD

Introduction

Environmental Spec
Temperature Operating: 5°C - 35°C Non-Operating: -20°C - 60°C
Relative Humidity Operating: 20% - 80% Non-Operating: 10% - 90%
Optional
Super Multi Drive Module Blu-Ray Combo Drive Module Intel® WiFi Link 5300/5100 Series (3*3/1*2 - 802.11a/g/n) Wireless LAN PCIe Interface Mini-Card Module 3rd Party 802.11b/g Wireless LAN PCIe Interface Mini-Card Module Bluetooth 2.1 + EDR (Enhanced Data Rate) Module (Factory Option) 2.0M or 3.0M Pixel USB 2.0 PC Camera Module (Factory Option) Fingerprint Reader Module (Factory Option) Mini-Card TV Tuner Module with USB Interface (Factory Option)

External Locator - Top View with LCD Panel Open



Figure 1
Top View

1. Optional Built-In PC Camera
2. LCD
3. LED Status Indicators
4. Touch Sensor Instant Keys
5. 8 * Gaming Keys
6. Keyboard
7. TouchPad and Buttons
8. Fingerprint Reader Module (**optional**)
9. LED Power Indicators

Introduction

Figure 2
Front Views

1. Color LEDs
2. Speakers
3. LED Power Indicators
4. Consumer Infrared Transceiver (enabled with optional TV Tuner only)

External Locator - Front & Right side Views



Figure 3
Right Side Views

5. Headphone-In Jack
6. Microphone-In Jack
7. Line-In Jack
8. S/PDIF-Out Jack
9. Cable (CATV) Antenna Jack*
10. Combined eSATA/USB Port
11. USB 2.0 Port
12. Security Lock Slot
13. Power Button



External Locator - Left Side & Rear View



Figure 4
Left Side View

1. DVI-Out Port
2. 2 * USB 2.0 Ports
3. RJ-45 LAN Jack
4. HDMI-Out Port
5. 7-in-1 Card Reader
6. ExpressCard Slot
7. Mini-IEEE 1394 Port
8. Optional Device Drive Bay



Figure 5
Rear View

9. Color LEDs
10. Speakers
11. DC-In Jack

External Locator - Bottom View

Figure 6
Bottom View

1. Sub Woofer
2. Fan Outlet/Intake
3. Component Bay Cover
4. Battery (Secondary HDD Bay - HDD3)
5. Primary HDD Bay (HDD1 & 2)



Overheating

To prevent your computer from overheating make sure nothing blocks the vent/fan intakes while the computer is in use.

Mainboard Overview - Top (Key Parts)

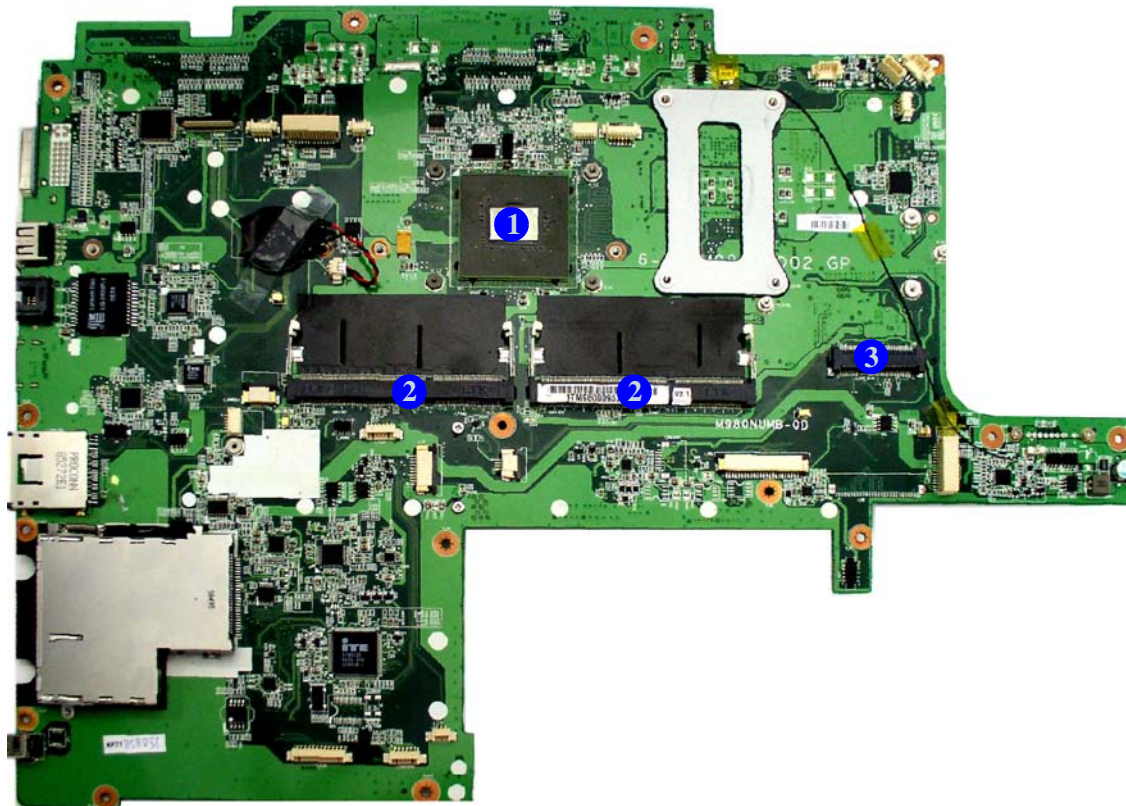

Figure 7
**Mainboard Top
Key Parts**

1. North Bridge
2. Memory Slots
DDR3 So-DIMM
3. Mini-Card
Connector (WLAN
Module)

Introduction

Figure 8
**Mainboard Bottom
Key Parts**

1. CPU Socket
2. VGA Socket
3. Mini-Card Connector (TV Module)

Mainboard Overview - Bottom (Key Parts)

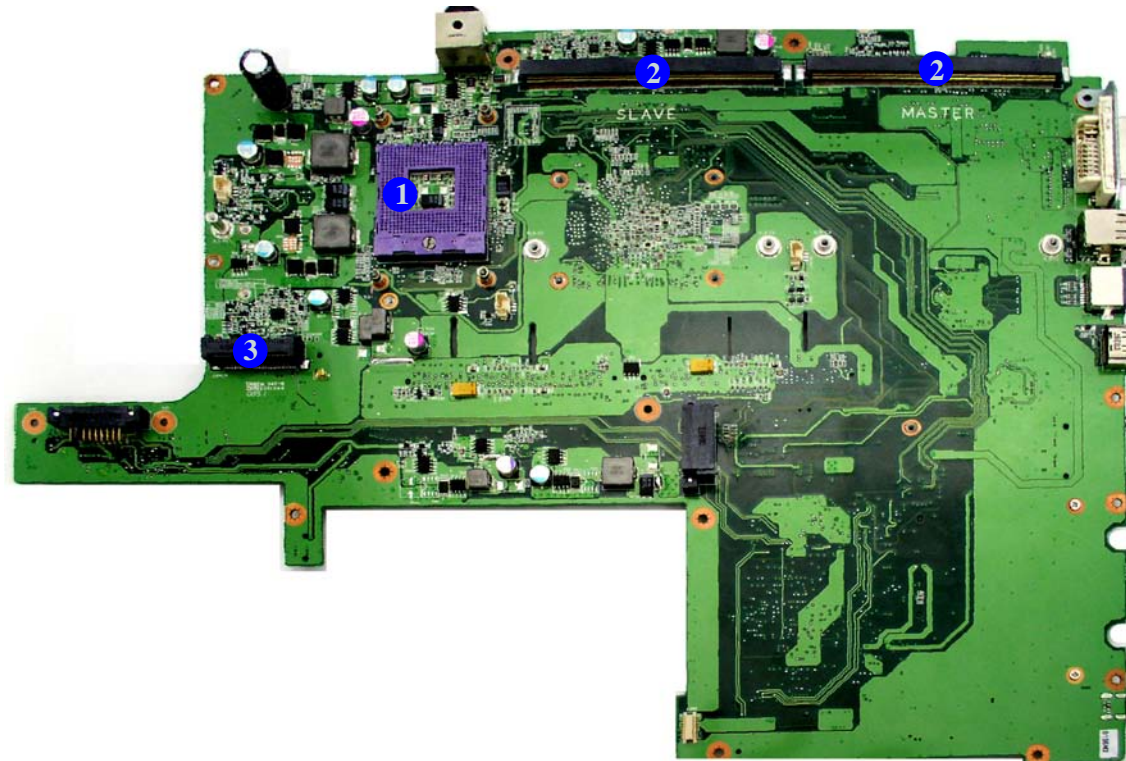

Mainboard Overview - Top (Connectors)

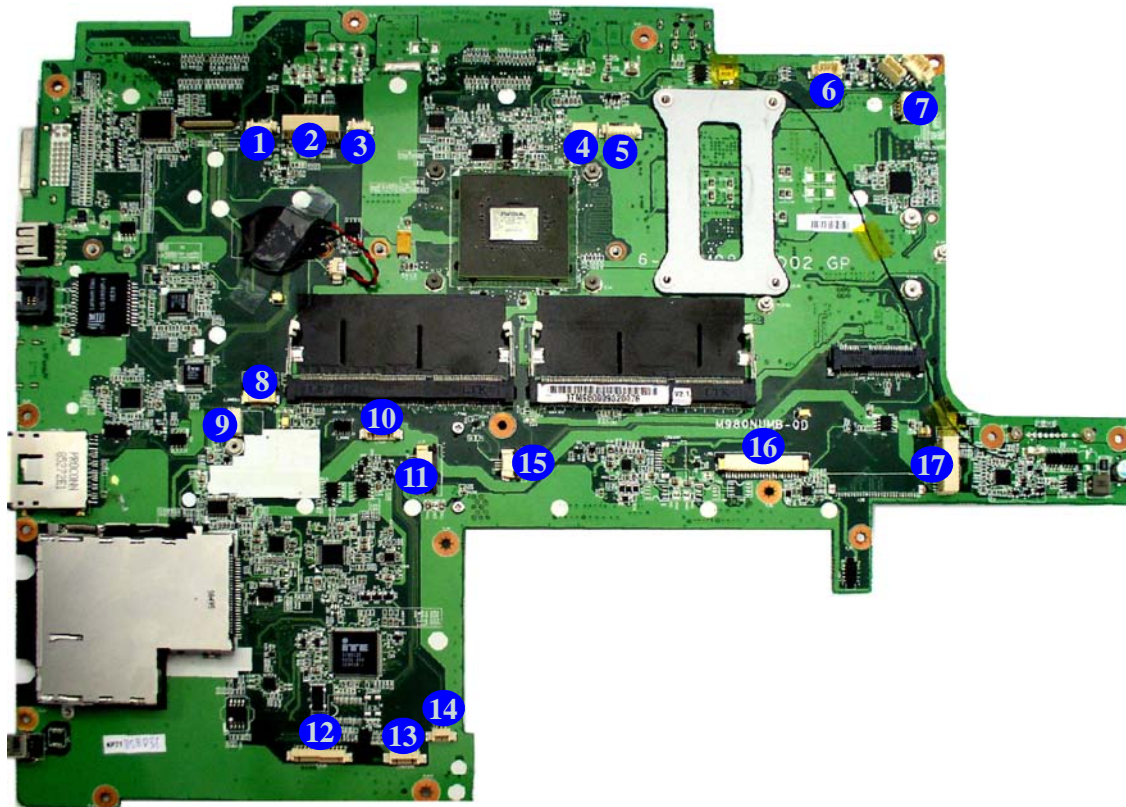

Figure 9
Mainboard Top Connectors

1. CCD Cable Connector
2. LCD Cable Connector
3. Side L Cable Connector
4. Inverter Cable Connector
5. LED Cable Connector
6. Subwoofer Connector
7. Power Button Connector
8. Game-Key Cable Connector
9. Bluetooth Module Connector
10. LED Cable Connector
11. Touch Pad Connector
12. USB Cable Connector
13. Audio Cable Connector
14. SW Connector
15. Fingerprint Connector
16. Keyboard Cable Connector
17. Audio Cable Connector

Introduction

Figure 10
**Mainboard Bottom
Connectors**

Mainboard Overview - Bottom (Connectors)

1. Battery Connector

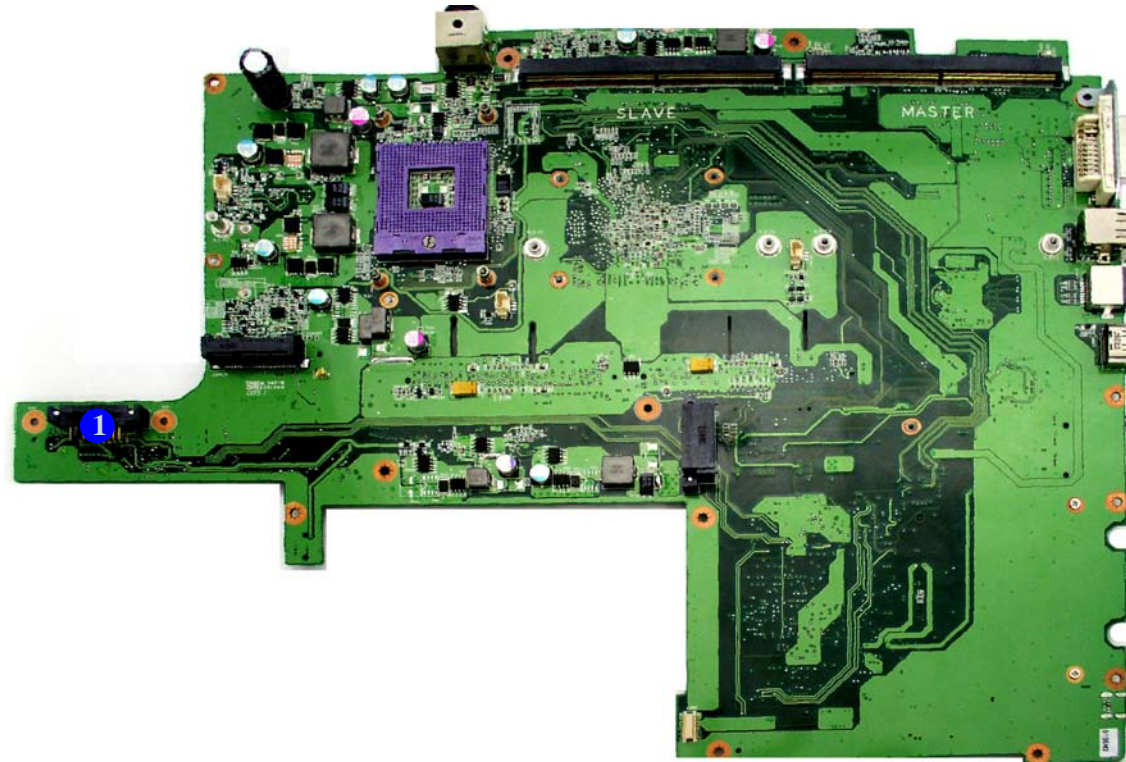

Chapter 2: Disassembly

Overview

This chapter provides step-by-step instructions for disassembling the *M980NU* series notebook's parts and subsystems. When it comes to reassembly, reverse the procedures (unless otherwise indicated).

We suggest you completely review any procedure before you take the computer apart.

Procedures such as upgrading/replacing the RAM, optical device and hard disk are included in the User's Manual but are repeated here for your convenience.

To make the disassembly process easier each section may have a box in the page margin. Information contained under the figure # will give a synopsis of the sequence of procedures involved in the disassembly procedure. A box with a  lists the relevant parts you will have after the disassembly process is complete. **Note:** The parts listed will be for the disassembly procedure listed ONLY, and not any previous disassembly step(s) required. Refer to the part list for the previous disassembly procedure. The amount of screws you should be left with will be listed here also.

A box with a  will also provide any possible helpful information. A box with a  contains warnings.

An example of these types of boxes are shown in the sidebar.

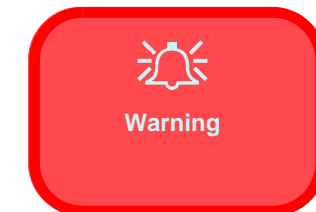
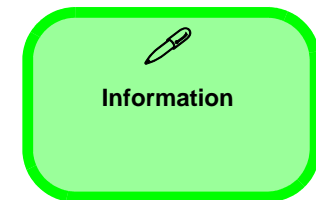

Disassembly

NOTE: All disassembly procedures assume that the system is turned **OFF**, and disconnected from any power supply (the battery is removed too).

Maintenance Tools

The following tools are recommended when working on the notebook PC:

- M3 Philips-head screwdriver
- M2.5 Philips-head screwdriver (magnetized)
- M2 Philips-head screwdriver
- Small flat-head screwdriver
- Pair of needle-nose pliers
- Anti-static wrist-strap

Connections

Connections within the computer are one of four types:

Locking collar sockets for ribbon connectors	To release these connectors, use a small flat-head screwdriver to gently pry the locking collar away from its base. When replacing the connection, make sure the connector is oriented in the same way. The pin1 side is usually not indicated.
Pressure sockets for multi-wire connectors	To release this connector type, grasp it at its head and gently rock it from side to side as you pull it out. Do not pull on the wires themselves. When replacing the connection, do not try to force it. The socket only fits one way.
Pressure sockets for ribbon connectors	To release these connectors, use a small pair of needle-nose pliers to gently lift the connector away from its socket. When replacing the connection, make sure the connector is oriented in the same way. The pin1 side is usually not indicated.
Board-to-board or multi-pin sockets	To separate the boards, gently rock them from side to side as you pull them apart. If the connection is very tight, use a small flat-head screwdriver - use just enough force to start.

Maintenance Precautions

The following precautions are a reminder. To avoid personal injury or damage to the computer while performing a removal and/or replacement job, take the following precautions:

1. **Don't drop it.** Perform your repairs and/or upgrades on a stable surface. If the computer falls, the case and other components could be damaged.
2. **Don't overheat it.** Note the proximity of any heating elements. Keep the computer out of direct sunlight.
3. **Avoid interference.** Note the proximity of any high capacity transformers, electric motors, and other strong magnetic fields. These can hinder proper performance and damage components and/or data. You should also monitor the position of magnetized tools (i.e. screwdrivers).
4. **Keep it dry.** This is an electrical appliance. If water or any other liquid gets into it, the computer could be badly damaged.
5. **Be careful with power.** Avoid accidental shocks, discharges or explosions.
 - Before removing or servicing any part from the computer, turn the computer off and detach any power supplies.
 - When you want to unplug the power cord or any cable/wire, be sure to disconnect it by the plug head. Do not pull on the wire.
6. **Peripherals** – Turn off and detach any peripherals.
7. **Beware of static discharge.** ICs, such as the CPU and main support chips, are vulnerable to static electricity. Before handling any part in the computer, discharge any static electricity inside the computer. When handling a printed circuit board, do not use gloves or other materials which allow static electricity buildup. We suggest that you use an anti-static wrist strap instead.
8. **Beware of corrosion.** As you perform your job, avoid touching any connector leads. Even the cleanest hands produce oils which can attract corrosive elements.
9. **Keep your work environment clean.** Tobacco smoke, dust or other air-borne particulate matter is often attracted to charged surfaces, reducing performance.
10. **Keep track of the components.** When removing or replacing any part, be careful not to leave small parts, such as screws, loose inside the computer.

Cleaning

Do not apply cleaner directly to the computer, use a soft clean cloth.

Do not use volatile (petroleum distillates) or abrasive cleaners on any part of the computer.



Power Safety Warning

Before you undertake any upgrade procedures, make sure that you have turned off the power, and disconnected all peripherals and cables (including telephone lines). It is advisable to also remove your battery in order to prevent accidentally turning the machine on.

Disassembly Steps

The following table lists the disassembly steps, and on which page to find the related information. **PLEASE PERFORM THE DISASSEMBLY STEPS IN THE ORDER INDICATED.**

To remove the Battery:

1. Remove the battery *page 2 - 5*

To remove the Optical Device:

1. Remove the battery *page 2 - 5*
2. Remove the Optical device *page 2 - 6*

To remove the HDD:

1. Remove the battery *page 2 - 5*
2. Remove the HDD *page 2 - 7*

To remove the System Memory:

1. Remove the battery *page 2 - 5*
2. Remove the System Memory *page 2 - 9*

To remove the VGA card:

1. Remove the battery *page 2 - 5*
2. Remove the VGA card *page 2 - 11*

To remove the TV Tuner Card:

1. Remove the battery *page 2 - 5*
2. Remove the TV tuner card *page 2 - 14*

Removing the Battery

If you are confident in undertaking upgrade procedures yourself, for safety reasons it is best to remove the battery.

1. Turn the computer off, and turn it over.
2. Loosen screws ① - ③ and carefully lift the battery ④ up (*Figure b*) .
3. Remove the battery from the battery bay.

Figure 1
Battery Removal

- a. Loosen screws.
- b. Release the battery.
- c. Lift the battery out of the bay as indicated.

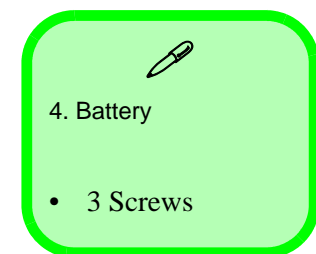
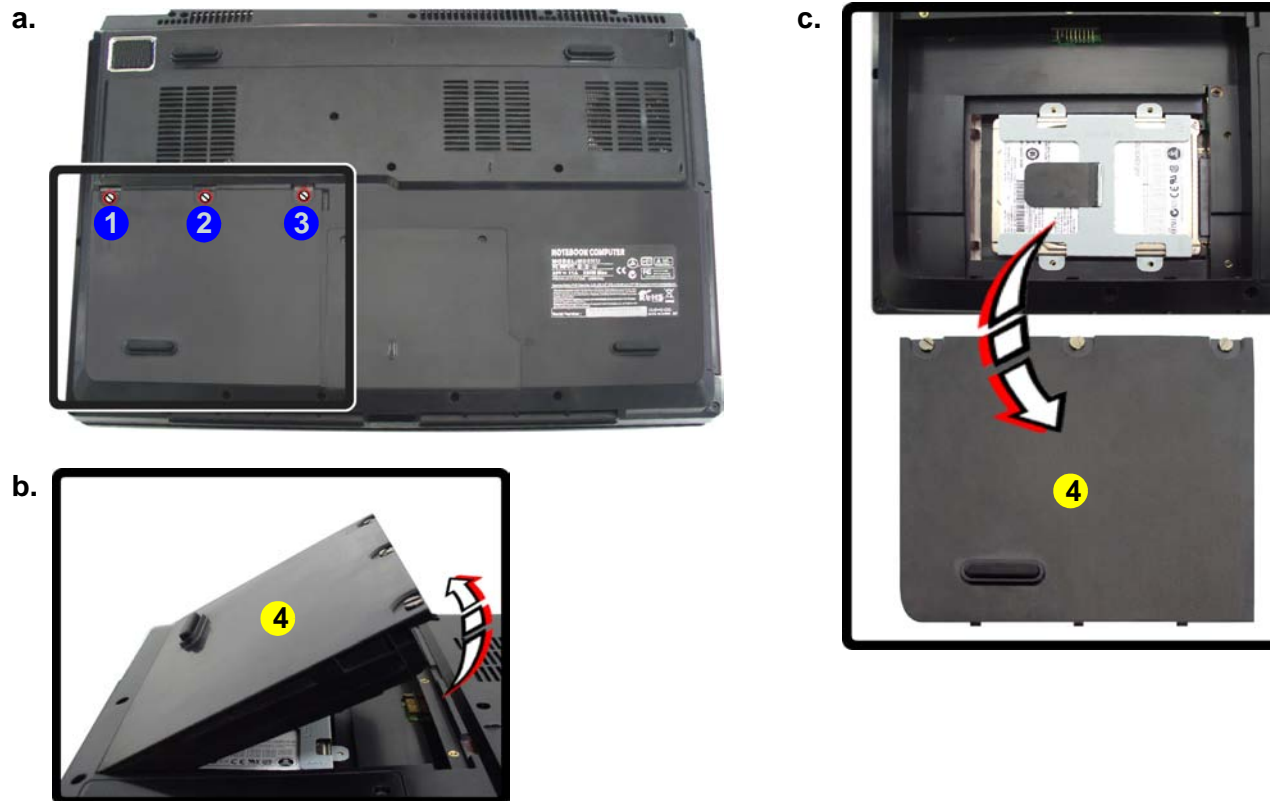

Disassembly

Figure 2
**Optical Device
Removal**

- Remove the screws.
- Remove the cover.
- Remove the screw and push the optical device out of the computer at point 8.

Removing the Optical (CD/DVD) Device

- Turn off the computer, and turn it over and remove the battery ([page 2 - 5](#)).
- Locate the hard disk bay cover and remove screws **1** & **2**, and remove the bay cover **3**.
- Remove screw **4**.
- Use the screwdriver to push the optical device **6** out of the computer at point **5**.
- Reverse the process to install the new device.

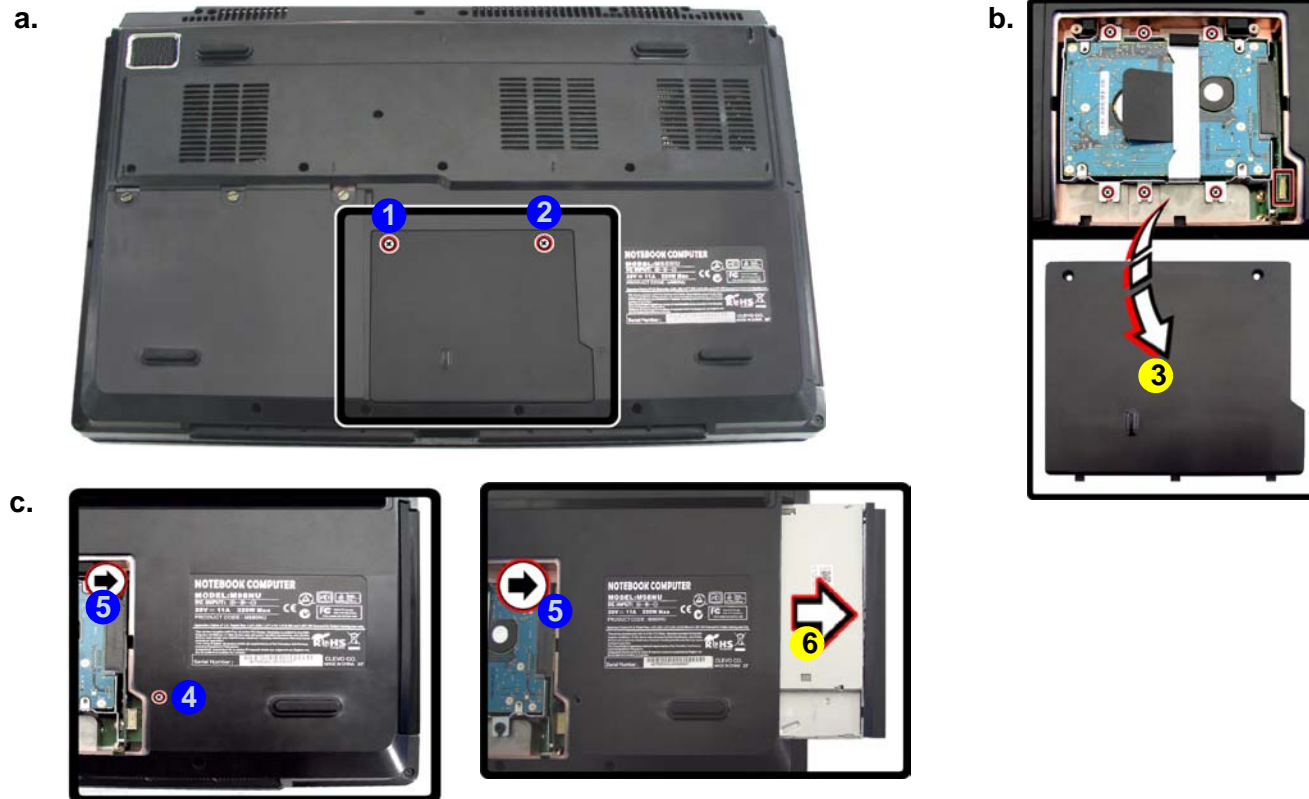

- Hard Disk Bay Cover
- Optical Device

- 3 Screws

Removing the Hard Disk Drive

The hard disk drive is mounted in a removable case and can be taken out to accommodate other 2.5" SATA hard disk drives with a height of 9.5mm (h). Follow your operating system's installation instructions, and install all necessary drivers and utilities (as outlined in **Chapter 4 of the User's Manual**) when setting up a new hard disk.

Hard Disk Upgrade Process

1. Turn off the computer, and turn it over and remove the battery ([page 2 - 5](#)).
2. Locate the hard disk bay cover and remove screws **1** & **2**.
3. Remove the bay cover **3**.
4. Remove screws **4** - **9** and pull the tab to disconnect the connector **10** from hard disk assembly.
5. Lift the hard disk assembly **11** out of the computer.
6. Remove screws **12** - **21** (depending on how many hard disks you have installed in the assembly).
7. Separate the hard disk board connector **22** from the case **23**.
8. Separate the hard disk(s) **24** from the case.
9. Reverse the process to install a new hard disk(s).

Figure 3
HDD Assembly Removal

- a. Remove the screws.
- b. Remove the cover
- c. Remove the screws and lift the hard disk assembly up out off the computer.
- d. Remove the screws and separate the HDD(s) from the connector and case.

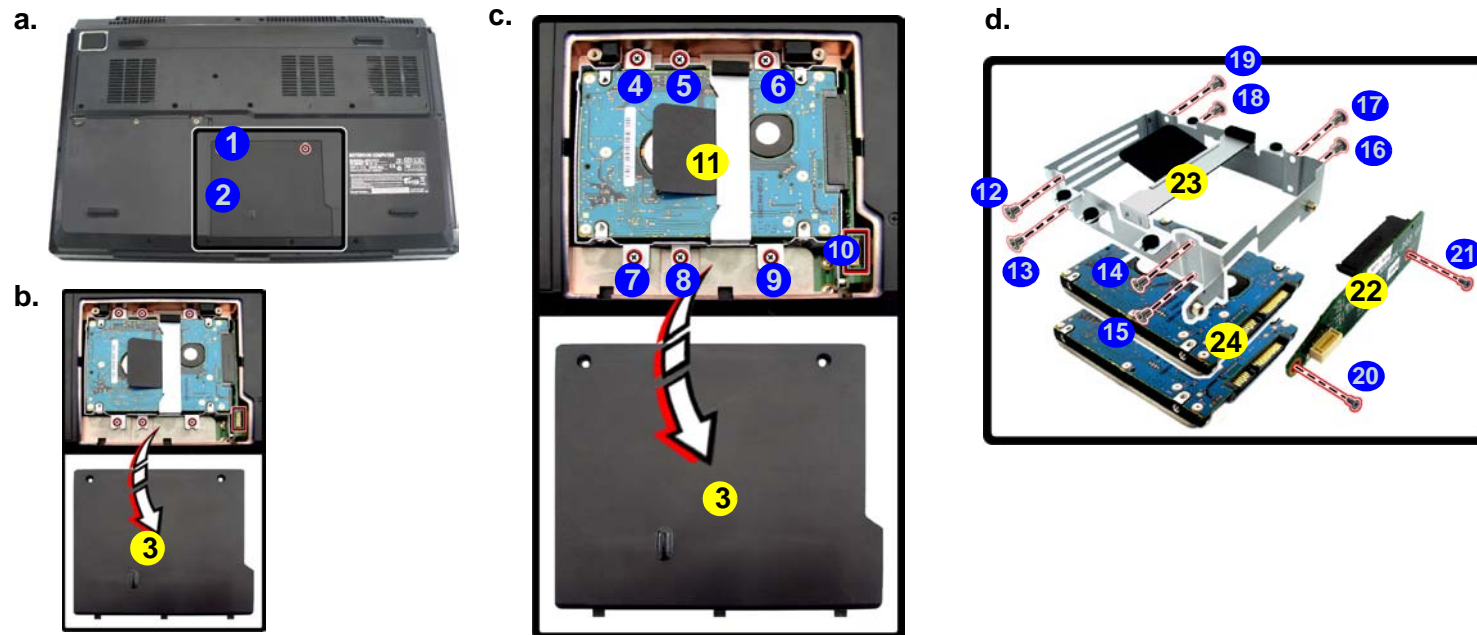



3. Hard Disk Bay Cover
11. Hard Disk Assembly
22. HDD connector
23. HDD case
24. HDD

- 18 Screws

Disassembly

Figure 4
**Secondary HDD
Assembly Removal**

- Remove the screws and slide the hard disk assembly in the direction of the arrow.
- Lift the hard disk assembly out of the computer.
- Remove the screws to release the hard disk from the case.

Removing the Hard Disk(s) in the Secondary HDD Bay

- Turn **off** the computer, and turn it over and remove the battery.
- The secondary hard disk bay is located under the battery compartment.
- Remove screw **1** - **4**.
- Slide the hard disk assembly in the direction of the arrow **5**.
- Lift the hard disk assembly **6** out of the compartment.
- Remove the screws **7** - **10** to release the hard disk from the case **11**.
- Reverse the process to install any new hard disk(s).

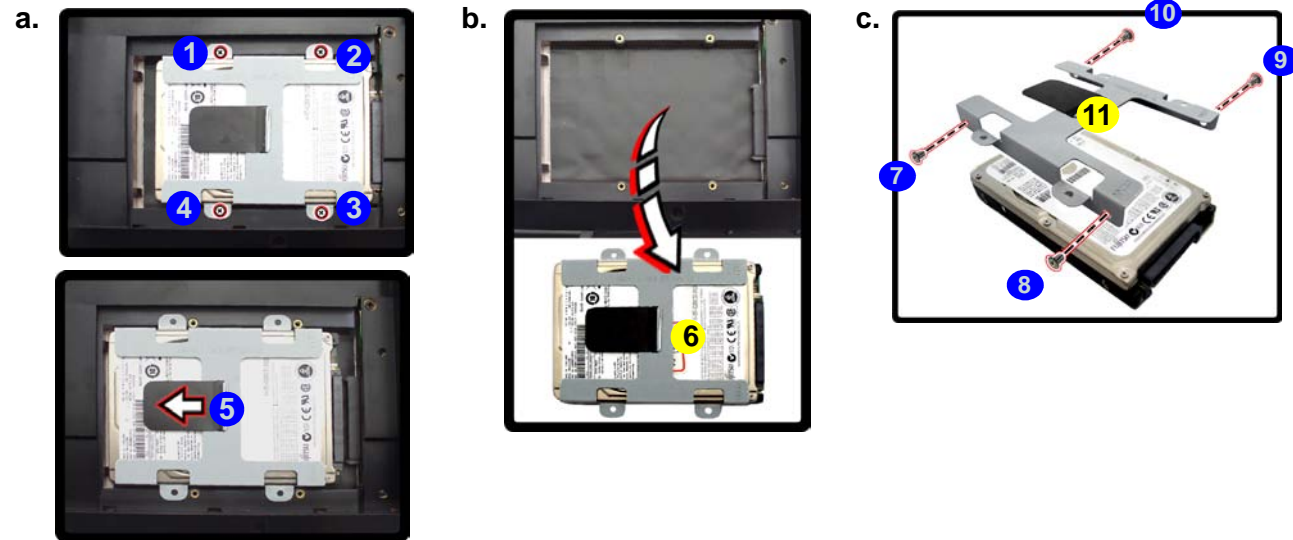

6. Hard Disk Assembly
11. Hard Disk Case

- 8 Screws

Removing the System Memory (RAM)

The computer has two memory sockets for 200 pin Small Outline Dual In-line Memory Modules (SO-DIMM) DDR III (DDR3) supporting 1066/1333 MHz. The main memory can be expanded up to 6GB. The SO-DIMM modules supported are 1024MB and 2048MB **DDR** Modules. The total memory size is automatically detected by the POST routine once you turn on your computer.

Memory Upgrade Process

1. Turn off the computer, and turn it over and remove the battery ([page 2 - 5](#)).
2. Remove screws **1** & **2** from the bottom of the computer.
3. Turn the computer over, open the Lid/LCD, and carefully (a cable **3** is connected to the underside of the LED cover module) lift up the LED cover module **4**
4. Remove screws **5** - **9** from the keyboard.

a.



c.



b.

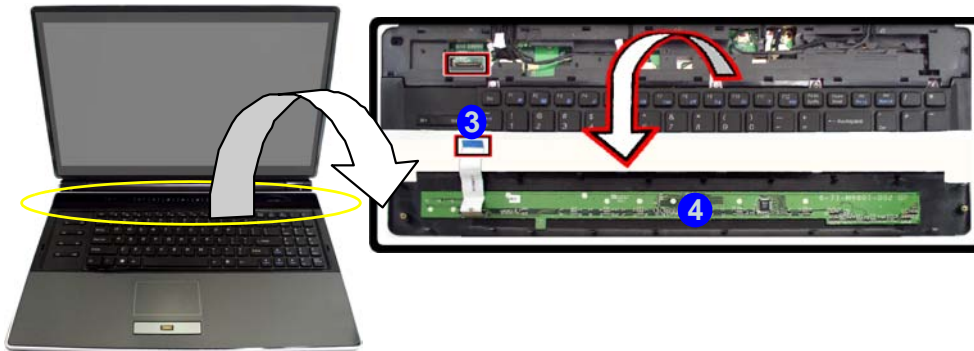

Figure 5
RAM Module Removal

- a. Remove the screws from the bottom of the computer.
- b. Turn the computer over, open the lid/LCD and lift the LED cover module.
- c. Remove the screws from the keyboard.



Caution

The heat sink, and CPU area in general, contains parts which are subject to high temperatures. Allow the area time to cool before removing these parts.



- 7 Screws

Disassembly

Figure 6 RAM Module Removal (cont'd.)

- d. Disconnect the cable from the locking collar.
- e. Remove the keyboard and keyboard plate.
- f. Pull the release latch(es).
- g. Remove the module(s).

5. Carefully lift the keyboard up, being careful not to bend the keyboard ribbon cable.
6. Disconnect the keyboard ribbon cable **10** from the locking collar socket **11**.
7. Remove the keyboard **12** and keyboard shielding plate **13**.

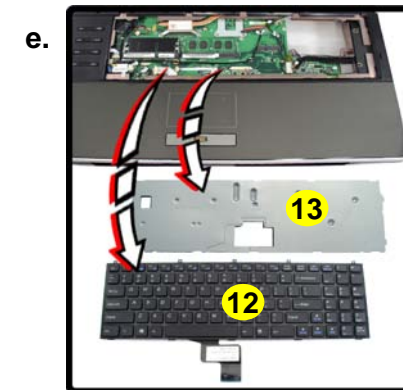
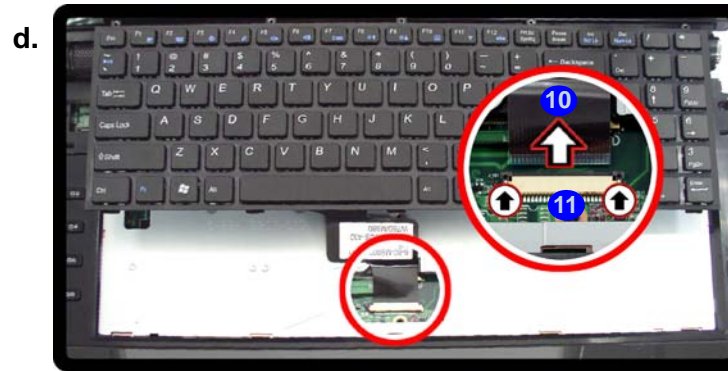

8. Gently pull the two **release latches 14 & 15** on the sides of the memory socket in the direction indicated by the arrows (**Figure f**).
9. The RAM module **16** will pop-up (**Figure g**), and you can then remove it.

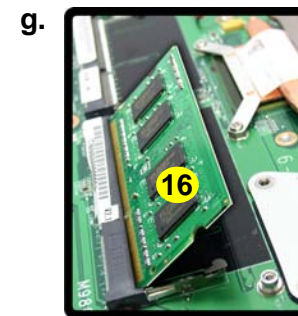
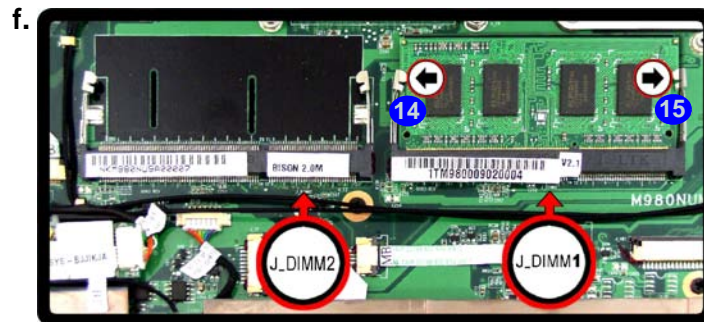

Contact Warning

Be careful not to touch the metal pins on the module's connecting edge. Even the cleanest hands have oils which can attract particles, and degrade the module's performance.



- 12. Keyboard
- 13. Keyboard Shielding Plate
- 16. RAM Module(s)



Single Memory Module Installation

If your computer has a single memory module, then insert the module into the **Channel 0 (JDIMM1)** socket as shown in **Figure 6 f**.

10. Pull the latches to release the second module if necessary.
11. Insert a new module holding it at about a 30° angle and fit the connectors firmly into the memory slot.
12. The module's pin alignment will allow it to only fit one way. Make sure the module is seated as far into the socket as it will go. **DO NOT FORCE** the module; it should fit without much pressure.
13. Press the module in and down towards the mainboard until the slot levers click into place to secure the module.
14. Replace the heat sink unit, RAM fan, cover and screws.
15. Restart the computer to allow the BIOS to register the new memory configuration as it starts up.

Removing the VGA Card

1. Turn off the computer, and turn it over and remove the battery ([page 2 - 5](#)).
2. Locate the component bay cover and remove screws **1** - **5**.
3. Carefully (**a fan and cable are attached to the under side of the cover**) lift up the bay cover.
4. Carefully disconnect the fan cable **6**, and remove the bay cover **7**.
5. Remove screws **8** - **10** (two video cards are pictured here) from the video card fan(s) and disconnect the fan cable(s) **11** (if two cards are present).
6. Remove the VGA card fan **12**.

Figure 7
VGA Card Removal

- a. Remove the screws.
- b. Remove the cover and disconnect the cable(s).
- c. Remove the screws and release the VGA card fan.

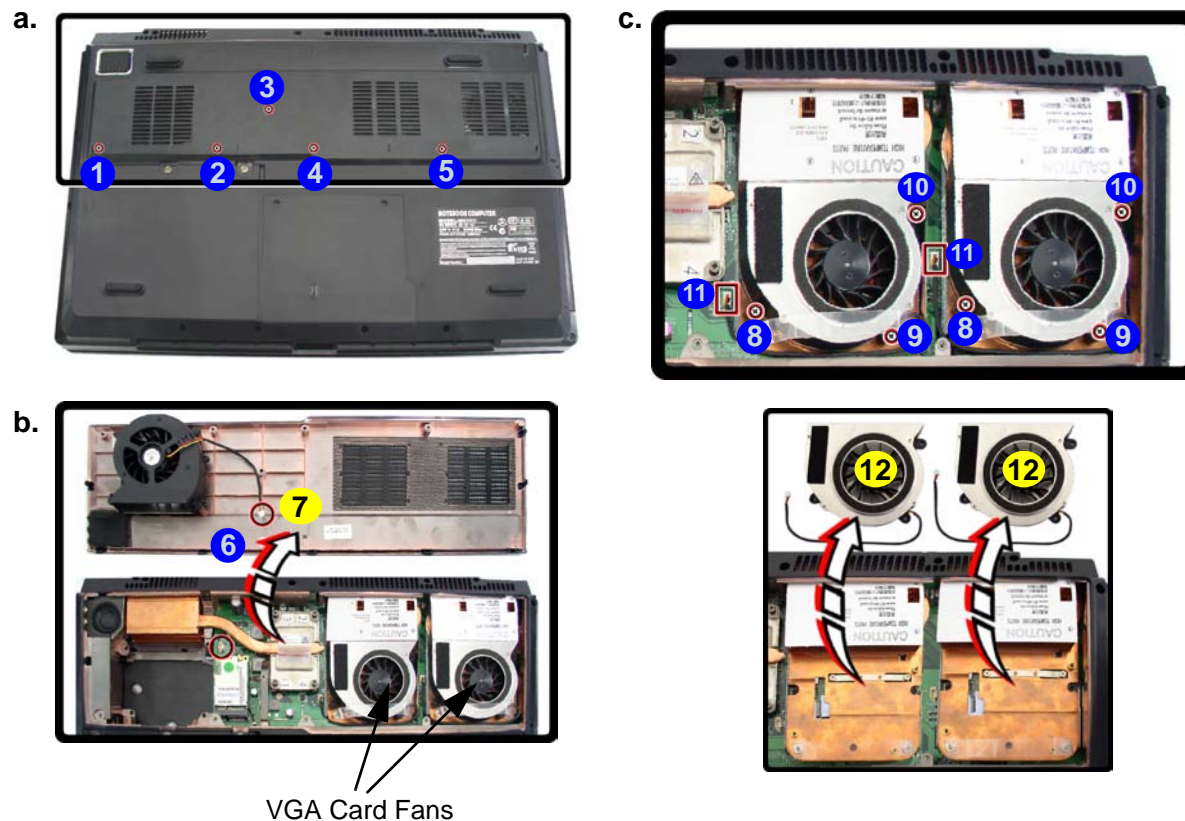

7. Bay Cover
12. VGA card fan

- 11 Screws

Disassembly

Figure 8
VGA Card Removal
(cont'd.)

- d. Remove the screws.
- e. Remove the VGA heat-sink.
- f. Remove the VGA module.

- 7. Remove screws **13** - **16** from the heatsink in the order indicated on the label (two video cards are pictured here).
- 8. Grip the handle **17** and carefully remove the heatsink **18**.
- 9. Remove screws **19** - **21** from the video card.
- 10. Carefully remove the VGA card module **22** from the mainboard.

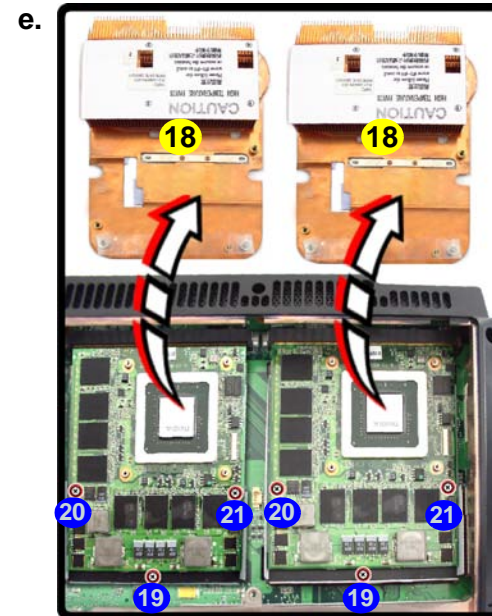
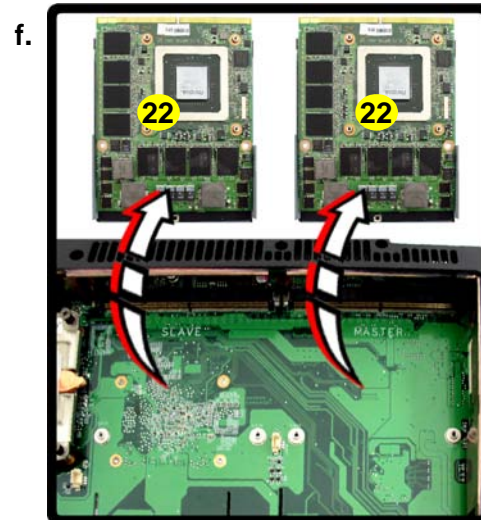
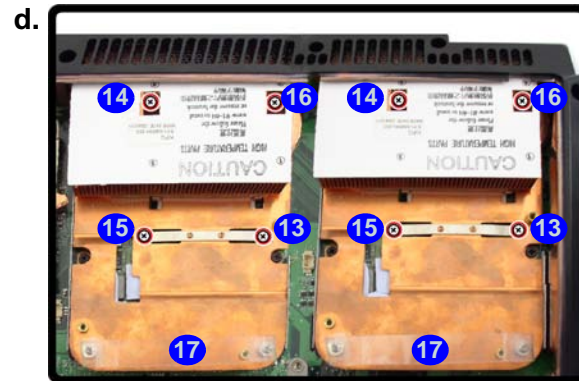

18. VGA Card Heatsink
22. VGA Card Module

- 16 Screws

- 11. Reverse the process to install a new VGA card modules.

Installing the VGA Card

1. Prepare to fit the VGA card **22** into the slot by holding it at about a 30° angle.
2. The card needs to be fully into the slot, and the VGA card and socket have a guide-key and pin which align to allow the card to fit securely.
3. Fit the connectors firmly into the socket, straight and evenly.
4. DO NOT attempt to push one end of the card in ahead of the other.
5. The card's pin alignment will allow it to only fit one way. **Make sure the module is seated as far into the socket as it will go** (none of the gold colored contact should be showing). DO NOT FORCE the card; it should fit without much pressure.
6. Secure the card with screws **19** - **21** (*Figure 8e on page 2 - 12*).
7. Place the heatsink **18** back on the card, and secure the screws in the order indicated in *Figure 8e on page 2 - 12*.
8. Attach the VGA card fan and secure with the screws as indicated in *Figure 7 on page 2 - 11*.
9. Reinsert the component bay cover, and secure with the screws as indicated in *Figure 7 on page 2 - 11*.

a.

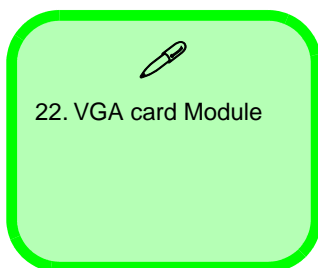
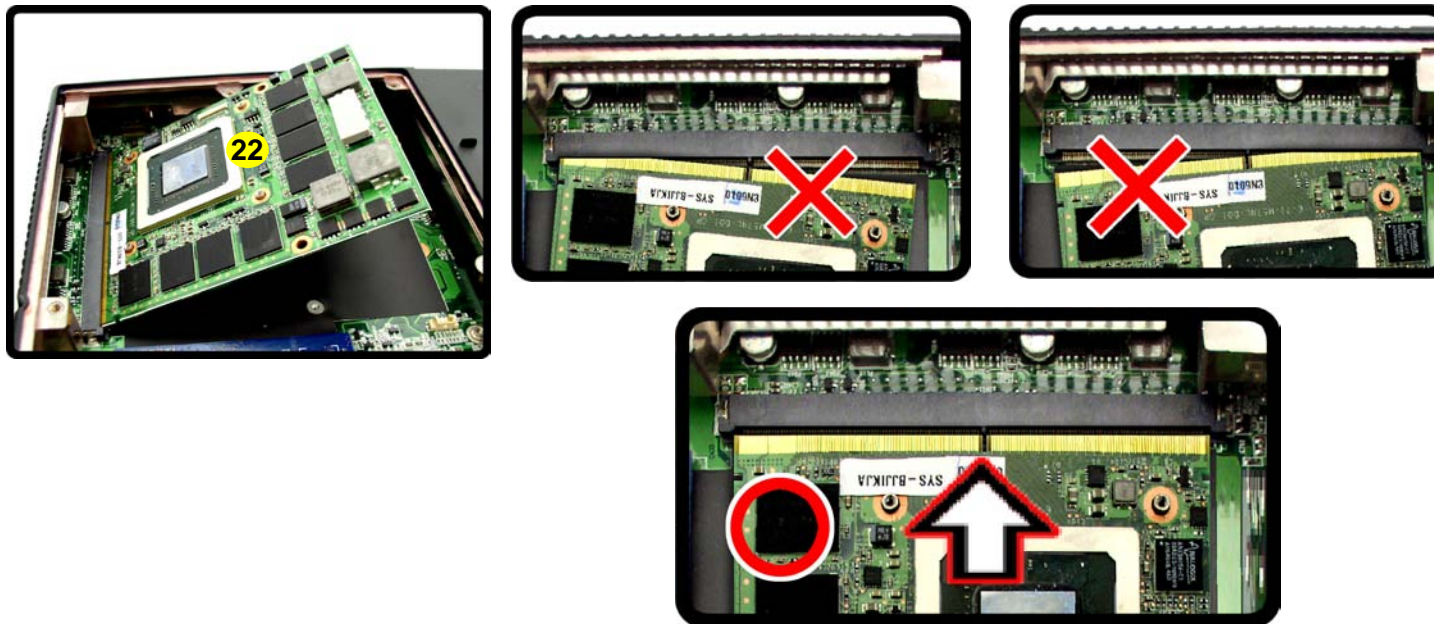

Figure 9
VGA Card Installation

a. Carefully Insert the VGA Card.

Disassembly

Figure 10
**TV Tuner Card
Removal**

- Remove the screws and disconnect the cable.
- The TV tuner card will pop up and remove it.

Removing the TV Tuner Card

- Turn off the computer, and turn it over, remove the battery ([page 2 - 5](#)).
- The TV tuner card is visible at point **1**.
- Remove the screw **2** from the TV tuner module and disconnect the cable **3**.
- The TV tuner card **4** will pop-up and you can remove it.

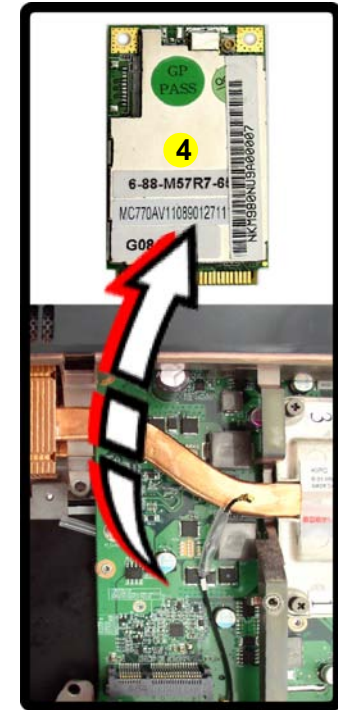

4. TV tuner card

- 1 Screw

Appendix A: Part Lists

This appendix breaks down the *M980NU* series notebook's construction into a series of illustrations. The component part numbers are indicated in the tables opposite the drawings.

Note: This section indicates the *manufacturer's* part numbers. Your organization may use a different system, so be sure to cross-check any relevant documentation.

Note: Some assemblies may have parts in common (especially screws). However, the part lists DO NOT indicate the total number of duplicated parts used.

Note: Be sure to check any update notices. The parts shown in these illustrations are appropriate for the system at the time of publication. Over the product life, some parts may be improved or re-configured, resulting in *new* part numbers.

Part List Illustration Location

The following table indicates where to find the appropriate part list illustration.

Table A- 1
**Part List Illustration
Location**

Parts	M980NU
Top with Fingerprint	<i>page A - 3</i>
Top without Fingerprint	<i>page A - 4</i>
Bottom	<i>page A - 5</i>
LCD	<i>page A - 6</i>
Mainboard	<i>page A - 7</i>
Blu-Ray Combo	<i>page A - 8</i>
DVD Super Multi	<i>page A - 9</i>

Top with Fingerprint

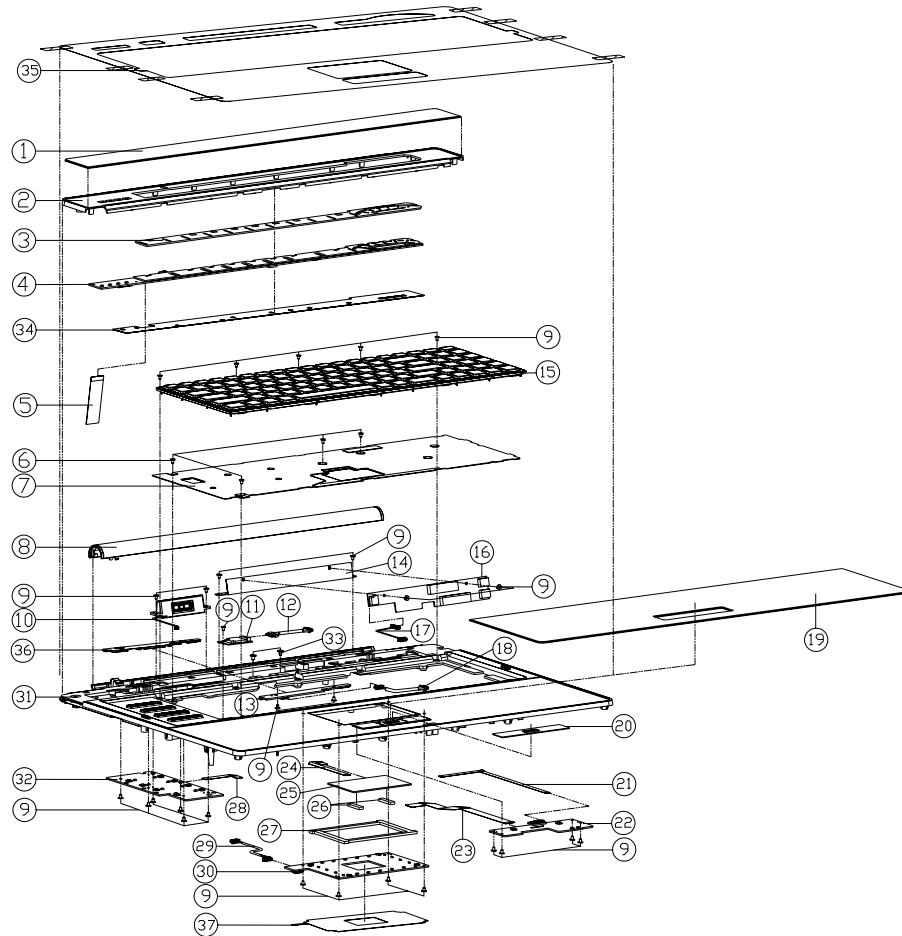

Figure A - 1
Top with
Fingerprint

ITEM	PART NAME	PART NO	REMARK
1	PMMA FOR CENTER COVER M980U	6-42-M9802-011	
2	CENTER COVER MODULE M980U	6-42-M9802-201	
3	LIGHT GUIDE FOR CENTER COVER PC M980U	6-42-M9802-092	
4	TOUCH SENSOR BOARD V30A M980U	6-77-M9801-003A	
5	WIRE CABLE FOR W/F TO TOUCH SENSOR EXP M980U	6-43-M9803-012	
6	SCREW HEX3L KI NI ICT NY	6-35-B1120-3RA	
7	KB SHIELDING MODULE SECC M980U	6-33-M9807-012	
8	INVERTOR COVER MODULE M980U	6-33-M9808-201	
9	SCREW HEX3L KI NI ICT NY	6-35-B1120-3RE	
10	PLATE HOLE FOR TOP CASE IN	6-22-M9800-020	
11	INVERTOR COVER MODULE SECC M980U	6-33-M9807-012	
12	WIRE CABLE FOR W/F TO INVERTOR COVER M980U	6-43-M745B-010	
13	BACK L SIDE LED BOARD V30A M980U	6-77-M9803-003A	
14	INVERTOR BKT SECC M980U	6-33-M9808-020	
15	K/B UNITS OF A FRAME AND MODULE M980U	6-79-M9800UK-190	
16	INVERTOR MODULE FOR INVERTOR COVER M980U	6-76-M9808-011	
17	WIRE CABLE FOR W/F TO INVERTOR OF M980U	6-43-M9808-011	
18	WIRE CABLE FOR W/F TO FINGER EXP M980U	6-43-M9800-071	
19	PMMA FOR PLAM RESET M980U	6-42-M9802-061	
20	PMMA FOR OP AND WITH FINGER M980U	6-42-M9802-071	
21	WIRE CABLE FOR W/F TO TOUCH PAD BOARD M980U	6-43-M980F-011	
22	CLICK BOARD/COVER BOARD FOR W/F M980U	6-77-M980A-N03-1	
23	WIRE CABLE FOR W/F TO CLICK PAD BOARD M980U	6-43-M9800-041	
24	WIRE CABLE FOR W/F TO TOUCH PAD BOARD M980U	6-43-M9802-011	
25	TOUCH PAD SYNAPTICS 1K-0298-011 M980U	6-49-M7452-010	
26	TOUCH PAD SPRING 080801 C0000 M980U	6-47-M9802-020	
27	LIGHT GUIDE FOR TOUCH PAD PC M980U	6-42-M9802-0A1	
28	WIRE CABLE FOR W/F TO CASE KEY BOARD M980U	6-43-M9800-011	
29	WIRE CABLE FOR W/F TO TOUCH PAD BOARD M980U	6-43-M9802-022	
30	TOUCH PAD LED BOARD V30A M980U	6-77-M980G-003A	
31	TOP CASE MODULE M980U	6-39-M9802-012	
32	GAME-KEY BOARD V30 M980U	6-77-M9807-003	
33	SCREW HEX3L KI NI ICT NY	6-35-B6125-5R0	
34	MILAR CU FOL FOR CENTER COVER M980U	6-40-M9802-030	
35	TOP CASE PROTECT-MILAR PRET M980U	6-40-M9802-020	
36	MILAR FOR FINGER SENSOR M980U	6-40-M9805-050	
37	TOUCH PAD LED BOARD MILAR PRET M980U	6-40-M9805-010	

A.Part Lists

Top without Fingerprint

Figure A - 2
Top without
Fingerprint

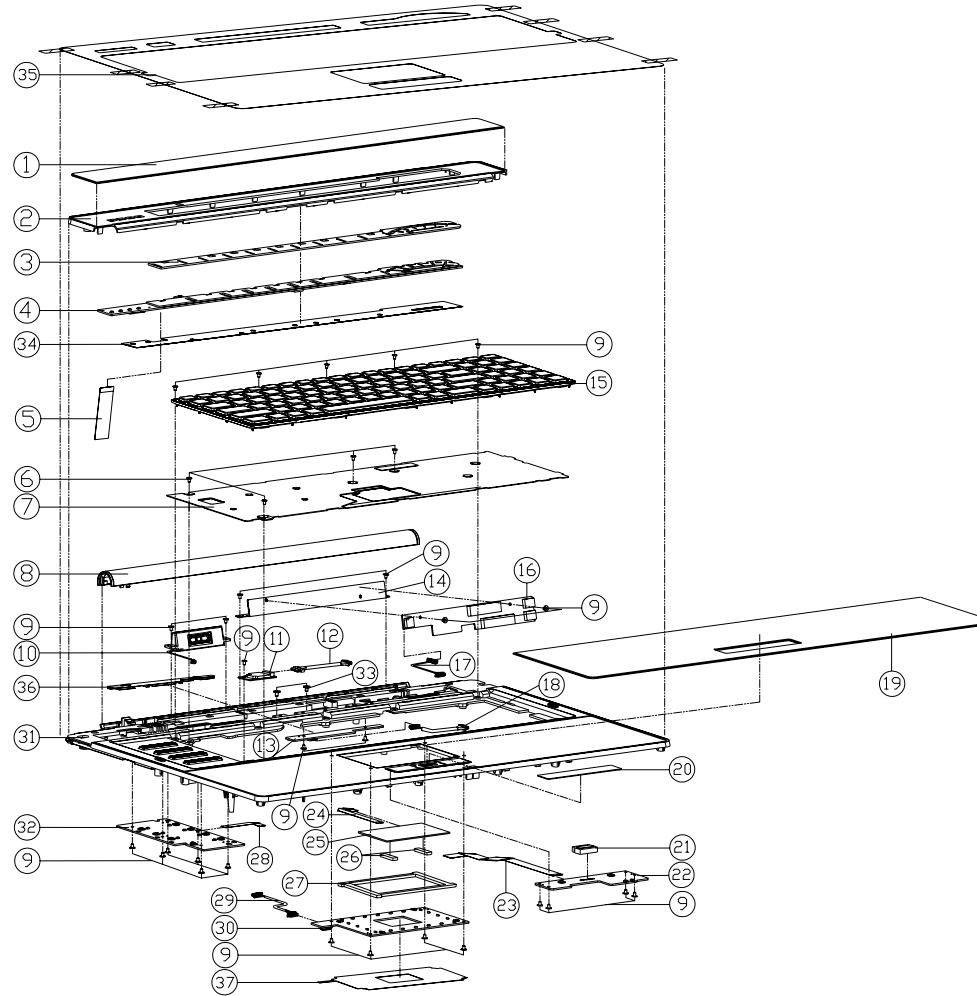

ITEM	PART NAME	PART NO	REMARK
1	PMMA FOR CENTER COVER M980U	6-42-M9802-011	
2	CENTER COVER MODULE M980U	6-42-M9802-201	
3	LIGHT GUIDE FOR CENTER COVER PC M980U	6-42-M9802-092	
4	TOUCH SENSOR BOARD V30A M980U	6-77-M9801-D03A	
5	WIRE CABLE FOR KB TO TOUCH-SENSOR CP M980U	6-43-M9803-012	
6	SCREW M2x3L KI NI ICT NY	6-35-B1120-3RA	
7	KB SHIELDING MODULE SECC M980U	6-33-M9807-012	
8	INVERTOR COVER MODULE M980U	6-33-M980R-201	
9	SCREW M2x3L KI NI ICT NY	6-35-B1120-3RE	
10	SPEAKER MODULE FOR TOP CASE 4 PIN	6-23-5M980-030	
11	INVERTOR MODULE	6-88-M73T5-3900	
12	WIRE CABLE FOR KB TO SPK BLUETOOTH MODULE FOR M980U	6-43-M745B-010	
13	BACK L SIDE LED BOARD V30A M980U	6-77-M9803-D03A	
14	INVERTOR BKT SECC M980U	6-33-M980R-020	
15	KB LED LIGHT FRAME-GRAB MODULE M980U	6-79-M980JOK-190	
16	INVERTOR MODULE FOR M980U	6-76-M980R-011	
17	WIRE CABLE FOR KB TO INVERTOR CP M980U V20	6-43-M980R-011	
18	WIRE CABLE FOR KB TO FAN-LED CP M980U	6-42-M9802-071	
19	PMMA FOR PLAM REST M980U	6-42-M9802-061	
20	PMMA FOR CP KNOB W/O FINGER M980U	6-42-M9802-081	
21	RUBBER FOR CP KNOB DUMMY M980U	6-47-M9802-050	
22	CLOCK BOARD V30A/W/O FFP M980U	6-77-M9802-D03A	
23	FFC CABLE FOR M9 TO CLICK BOARD V20	6-43-M9800-041	
24	FFC CABLE FOR M9 TO TOUCH PAD BOARD V20	6-43-M9800-011	
25	TOUCH PAD SYNAPTICS TM-0098-001 M745	6-49-M745S-010	
26	TOUCH PAD SPONGE 08x50 08x35 M980U	6-47-M9802-020	
27	LIGHT GUIDE FOR TOUCH PAD PC M980U	6-42-M9802-0A1	
28	FFC CABLE FOR M9 TO GAME-KEY-LED CP M980U	6-43-M9800-011	
29	WIRE CABLE FOR M9 TO TOUCH-PAD-LED CP M980U	6-43-M9802-021	
30	TOUCH PAD LED BOARD V30A M980U	6-77-M980G-D03A	
31	TOP CASE MODULE M980U	6-39-M9802-012	
32	GAME-KEY BOARD V30 M980U	6-77-M9807-D03	
33	SCREW M2.5x5L KI NI ICT NY	6-35-B6125-SR0	
34	NYLAR CU FOIL FOR CENTER COVER M980U	6-40-M9802-030	
35	TOP CASE PROTECT NYLAR-PET M980U	6-40-M9802-020	
36	NYLAR FOR FAN LED PCB/FR03 1-0405-M980U	6-40-M9805-050	
37	TOUCH PAD LED BOARD NYLAR-FR03 M980U	6-40-M9805-010	

Bottom

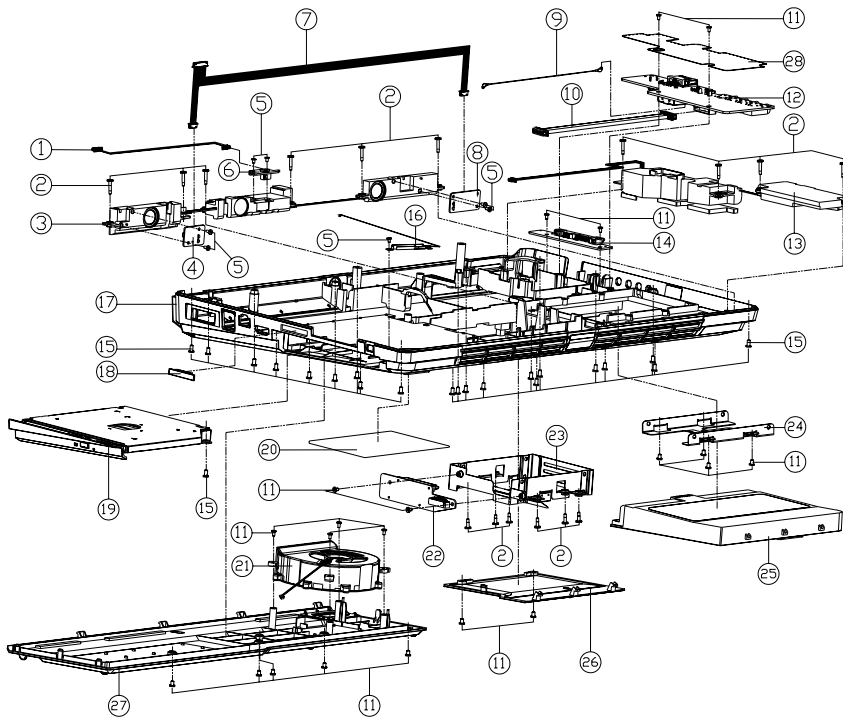

Figure A - 3
Bottom

ITEM	PART	NAME	PART	NO	REMARK
1	WIRE CABLE	TOP WIRE TO FRONT-BOTTOM OF FRONT	6-43-M9800-020		
2	SCREW	M2.5x6 Lx4.5 5x2.5 K Nl ICT	6-35-01120-750		
3	SPACER	L-R MODULE BY 4	6-23-SM980-022		
4	FRONT R SIDE LED BOARD	V3.0A M980J	6-77-M9804-003A		
5	SCREW	M2.5x6 Lx4.5 5x2.5 K Nl ICT	6-35-01120-3RE		
6	CIR. BOARD	V3.0 ASS'Y M980J	6-77-M980H-003		
7	WIRE CABLE	FOR WIRE TO LED-R of FRONT WIRE	6-43-M9800-061		
8	FRONT L SIDE LED BOARD	V3.0A M980J	6-77-M9805-003A		
9	CABLE	CABLE W/40 - 2MM FOR TV TUBER M980J	6-43-M980T-010		
10	WIRE CABLE	FOR WIRE TO AUDIO 3P M980J W/4	6-43-M9800-051		
11	SCREW	M2.5x6 Lx4.5 5x2.5 K Nl ICT	6-35-06125-50A		
12	AUDIO BOARD	V3.0 M980J	6-77-M980B-003		
13	SPACER	L-R MODULE BY 4	6-23-SM980-011		
14	PCB	SINGLE HDD BOARD V3.0A M980J	6-77-M980J-003A		
15	SCREW	M2.5x6 Lx4.5 5x2.5 K Nl ICT	6-35-06125-800		
16	ALUMINUM	ALUMINUM 24 PIA, L 10MM IT	6-23-7M980-040		
17	BOTTOM CASE	MODULE M980J	6-39-M9803-012		
18	CABLE	KEYT TUBER HE-4000 W/40 W/40	6-47-M980E-011		
19	SATA	ATA SUPER MULTI 2400R ASSY M980J	6-79-M980J00-000		
20	SATA	ATA SUPER MULTI 2400R ASSY M980J	6-79-M980J00-000		
21	PRODUCT	LABEL M980J	6-45-M9803-012		
22	FAN	LANCUM BY 43 8000RPM 3000A R	6-23-AM980-010		
23	DUAL	HDD BOARD V3.0 M980J	6-77-M980K-003		
24	HDD	3 BKT MODULE M980J	6-33-M980J-100		
25	HDD	3 BKT MODULE M980J	6-33-M980J-200		
26	HDD	COVER PC-ABS(C)40 M980J	6-87-M9805-4X51		
27	CPU	COVER MODULE M980J	6-42-M980J-011		
28	AUDIO	BOARD W/40A FREEZ M980J	6-40-M9805-020		

A.Part Lists

LCD

Figure A - 4
LCD

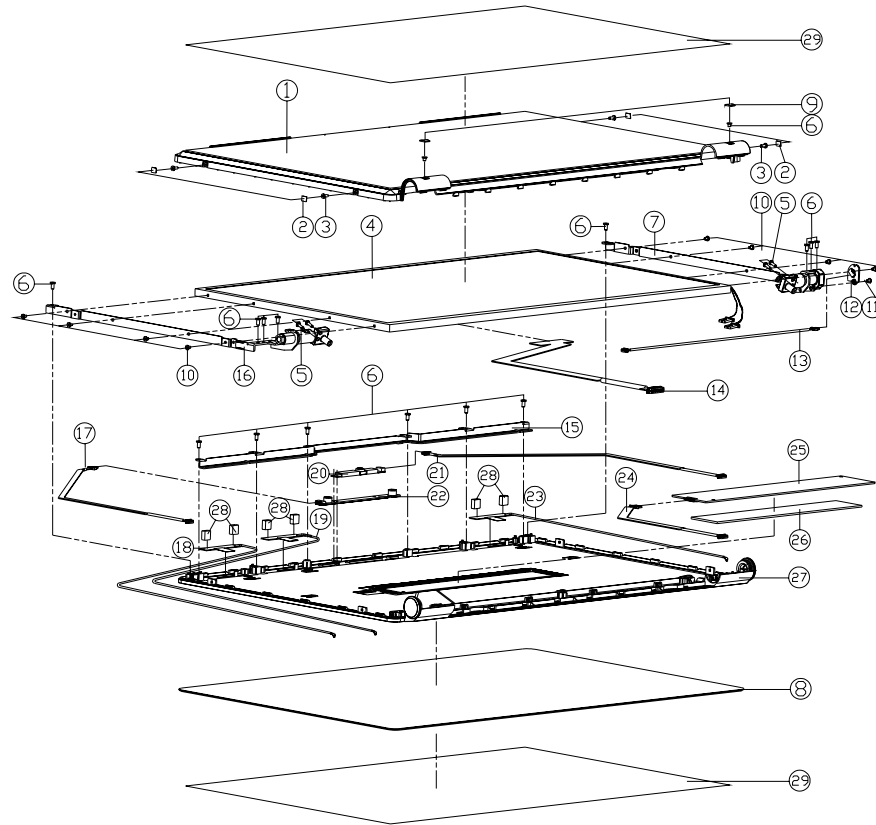

ITEM	PART NAME	PART NO	REMARK
1	LCD FRONT COVER MIDDLE M9800J	6-39-M9801-011	
2	LCD SCREW MYLAR M9800J	6-40-M9801-021	
3	SCREW M2.5xL K1 NI ICT NY	6-35-B1120-5R0	
4	LCD BKT FIB OPTIC LENS M9800J	6-50-P28265-M00	
4	LCD BKT FIB OPTIC M9800J	6-50-P28265-D03	
4	LCD BKT FIB OPTIC LENS M9800J	6-50-P28265-D01	
5	SCREW M2.5xL K1 BK/Z NY ICT	6-35-B6125-8R0	
6	SCREW M2.5xL K1 BK/Z ICT NY	6-35-B6125-5R4	
7	LCD HINGE R (SECC) M9800J	6-33-M9801-022	
8	LCD HINGE L (SECC) M9800J	6-42-M9801-032	
9	HINGE CAP RUBBER SILICONE B0 M9800J	6-47-M9801-020	
10	SCREW M2.5xL K1 NI ICT NY	6-35-B1120-3R4	
11	SCREW M2.5xL K1 BK/Z NY ICT	6-35-B1120-5R2	
12	POWER BUTTON BOARD V3.0A M9800J	6-77-M9806-003A	
13	WIRE CABLE FOR M9 TO POWER BUTTON M9800J	6-43-M9800-020	
14	WIRE CABLE FOR M9 TO LCD TOP M9800J	6-43-M9801-011	
15	LCD BRACKET TOP SECC M9800J	6-33-M9801-011	
16	LCD HINGE L (SECC) M9800J	6-33-M9801-032	
17	WIRE CABLE FOR M9 TO M9800J	6-43-M9804-011	
18	M9800 J M9800 J M9800 J	6-23-7M980-011	
19	M9800 J M9800 J M9800 J	6-23-7M980-031	
20	WIRE CABLE FOR M9 TO LCD SP M9800J	6-88-M740C-4913	(OPTION)
21	WIRE CABLE FOR M9 TO LCD SP M9800J	6-43-M9801-021	
22	INTEGRAL M9800 J M9800 J	6-23-EM980-010	
23	M9800 J M9800 J M9800 J	6-23-7M980-021	
24	WIRE CABLE FOR M9 TO LCD-LEFT M9800J	6-43-M9800-031	
25	LED BOARD V3.0A M9800J	6-77-M9806-003A	
26	LIGHT GUIDE FOR LCD BACK COVER M9800J	6-42-M9801-080	
27	LCD BACK COVER MIDDLE M9800J	6-39-M9801-022	
28	M9800 J M9800 J M9800 J	6-47-0019A-080	
29	LCD PROTECT M9800J	6-40-M9801-040	

Mainboard

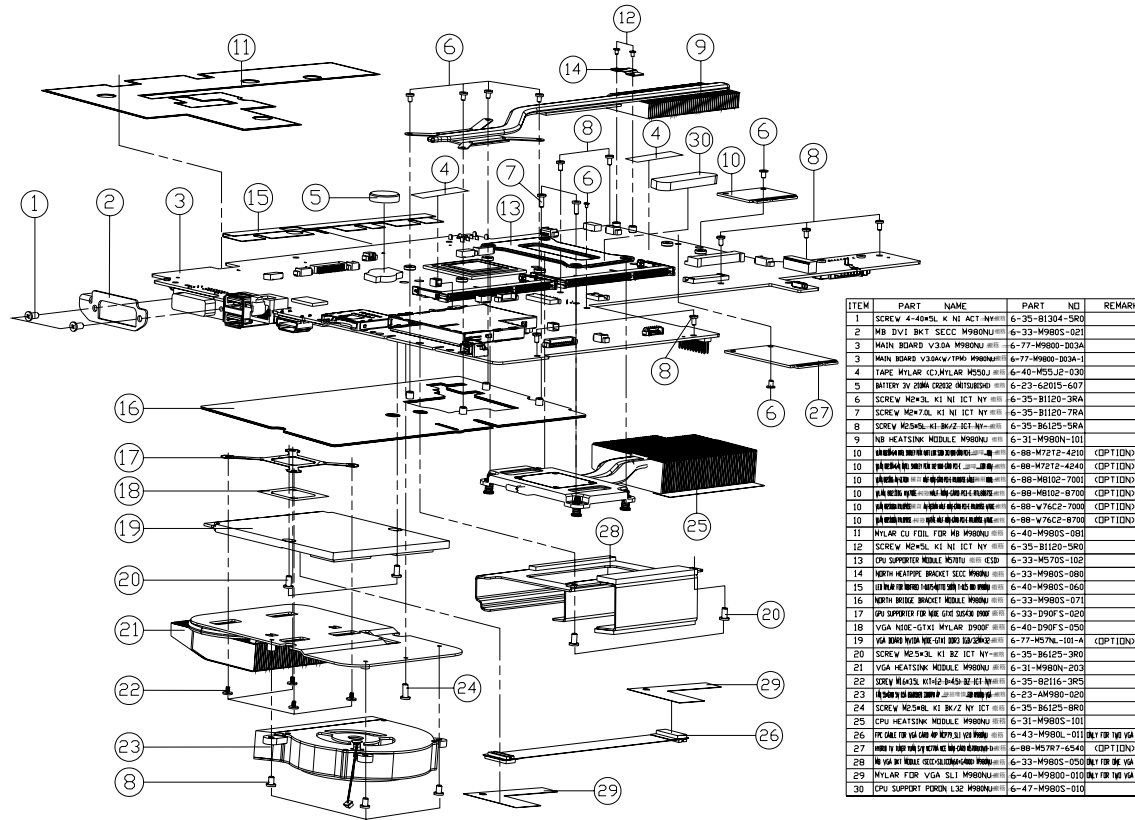

Figure A - 5
Mainboard

ITEM	PART NAME	PART NO	REMARK
1	SCREW 4-40xSL K NI ACT-NY#	6-35-81304-5R0	
2	MB DIV1 BKT SECC M980N#	6-33-M980S-021	
3	MAIN BOARD V3.0A M980J#	6-77-M980-003A	
3	MAIN BOARD V3.0A V1P0 M980J#	6-77-M980-003A-1	
4	TAPE NYLAR (C)NYLAR M550J#	6-40-M55J2-030	
5	BATTERY 3V 2000 UOZER M980B#	6-23-62035-507	
6	SCREW M2xSL KI NI ICT NY#	6-35-B1120-38A	
7	SCREW M2xSL KI NI ICT NY#	6-35-B1120-39A	
8	SCREW M2xSL KI BK/2 ICT-NY#	6-35-B6125-58A	
9	NB HEATSINK MODULE M980N#	6-31-M980N-101	
10	HEATSINK FOR MB CPU SOCKET	6-88-M712-4210	(OPT ION)
10	HEATSINK FOR MB GPU SOCKET	6-88-M712-4240	(OPT ION)
10	HEATSINK FOR MB CPU SOCKET	6-88-M8102-7001	(OPT ION)
10	HEATSINK FOR MB GPU SOCKET	6-88-M8102-8702	(OPT ION)
10	HEATSINK FOR MB CPU SOCKET	6-88-W76C2-7008	(OPT ION)
10	HEATSINK FOR MB GPU SOCKET	6-88-W76C2-8708	(OPT ION)
11	NYLAR CU FOIL FOR MB M980N#	6-40-M980S-081	
12	SCREW M2xSL KI NI ICT NY#	6-35-B1120-580	
13	GPU SUPPORTER MODULE M980J#	6-33-M570S-100	
14	NORTH HEAVY BRACKET SEC M980J#	6-33-M980S-080	
15	HEAVY BRACKET SEC M980J#	6-40-M980S-060	
16	NORTH BRIDGE BRACKET MODULE M980J#	6-33-M980S-071	
17	GPU SUPPORTER FOR MB GPU SOCKET	6-33-D90F S-020	
18	VGA NICE-GTXI NYLAR D900F#	6-40-D90F S-050	
19	VGA BRD NYLAR NYLAR D900F#	6-77-M57N-101-A	(OPT ION)
20	SCREW M2xSL KI BK ICT NY#	6-35-B6125-380	
21	VGA HEATSINK MODULE M980N#	6-31-M980N-210	
22	SCREW M2xSL KI BK/2 ICT-NY#	6-35-B2116-38S	
23	SCREW M2xSL KI BK/2 NY ICT	6-23-AM980-020	
24	SCREW M2xSL KI BK/2 NY ICT	6-35-B6125-880	
25	CPU HEATSINK MODULE M980N#	6-31-M980S-101	
26	PC CASE TOP VISA GRP NYLAR VISA M980J#	6-43-M980L-011	ONLY FOR THE VISA CASE
27	HEAVY BRACKET SEC M980J#	6-88-M5787-6540	(OPT ION)
28	NYLAR BRIDGE SEC M980J#	6-33-M980S-050	ONLY FOR THE VISA CASE
29	NYLAR FOR VGA SLT M980N#	6-40-M9800-010	ONLY FOR THE VISA CASE
30	CPU SUPPORT FORK L3C M980J#	6-47-M980S-010	

A.Part Lists

Blu-Ray Combo

Figure A - 6
Blu-Ray Combo

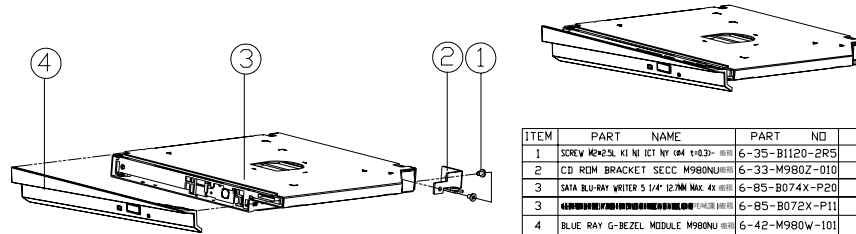

ITEM	PART NAME	PART NO	REMARK
1	SCREW M2x2.5, KI NI ICT NY (04 1-0.3)- (000)	6-35-B1120-2R5	
2	CD ROM BRACKET SECC M980NU(0000)	6-33-M980Z-010	
3	SATA BLU-RAY WRITER 5 1/4" 12.7MM MAX. 4X (000)	6-85-B074X-P20	
3	CD ROM BRACKET SECC M980NU(0000)	6-85-B072X-P11	
4	BLUE RAY G-BEZEL MODULE M980NU (000)	6-42-M980W-101	

DVD Super Multi

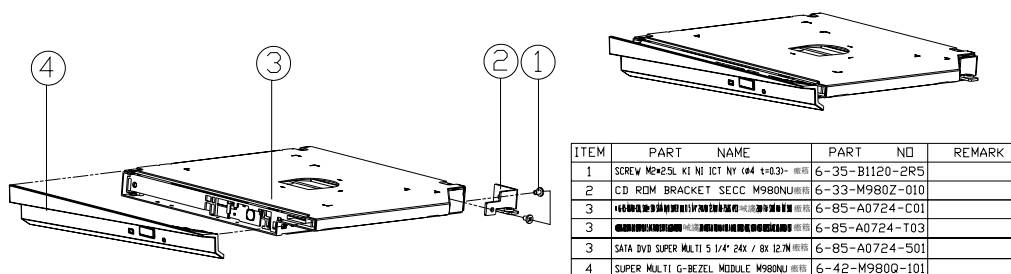

ITEM	PART NAME	PART NO	REMARK
1	SCREW M2x2.5L KI NI ICT NY (#4 1+0.3)	6-35-B1120-2R5	
2	CD ROM BRACKET SECC M980NJ	6-33-M980Z-010	
3	SATA DVD SUPER MULTI 5 1/4" 24X / 8X 12.7M	6-85-A0724-C01	
3	SATA DVD SUPER MULTI 5 1/4" 24X / 8X 12.7M	6-85-A0724-T03	
3	SATA DVD SUPER MULTI 5 1/4" 24X / 8X 12.7M	6-85-A0724-501	
4	SUPER MULTI G-BEZEL MODULE M980NJ	6-42-M9800-101	

Figure A - 7
DVD Super Multi

Appendix B: Schematic Diagrams

This appendix has circuit diagrams of the *M980NU* notebook's PCB's. The following table indicates where to find the appropriate schematic diagram.

Diagram - Page	Diagram - Page	Diagram - Page
<i>System Block Diagram - Page B - 2</i>	<i>CRT, DVI - Page B - 19</i>	<i>Power 1.0VS - Page B - 36</i>
<i>PENRYN 1/2 - Page B - 3</i>	<i>ODD, CCD, BT, USB 2.0 - Page B - 20</i>	<i>Power 3.3V/5V - Page B - 37</i>
<i>PENRYN3 2/2 - Page B - 4</i>	<i>KBC ITE IT8512-J - Page B - 21</i>	<i>Power Charger, DC-In - Page B - 38</i>
<i>MCP79 FSBI - Page B - 5</i>	<i>PHY RTL8211CL - Page B - 22</i>	<i>Single HDD Board - Page B - 39</i>
<i>MCP79 MEM CTRL (1) - Page B - 6</i>	<i>Codec, Subwoofer, DMIC - Page B - 23</i>	<i>Dual HDD Board - Page B - 40</i>
<i>MCP79 MEM CTRL (2) - Page B - 7</i>	<i>Audio AMP - Page B - 24</i>	<i>Audio Board - Page B - 41</i>
<i>MCP79 PCI-E - Page B - 8</i>	<i>HDMI Switch - Page B - 25</i>	<i>Power Button Board - Page B - 42</i>
<i>MCP79 LAN, Panel - Page B - 9</i>	<i>New Card, Mini Card - Page B - 26</i>	<i>Click & FP Board - Page B - 43</i>
<i>MCP79 PCI, LPC - Page B - 10</i>	<i>Card Reader, IEEE 1394 - Page B - 27</i>	<i>Logo LED Board - Page B - 44</i>
<i>MCP79 SATA, USB - Page B - 11</i>	<i>MXM 3.0 Master - Page B - 28</i>	<i>Game Key Board - Page B - 45</i>
<i>MCP79 HDA, Misc - Page B - 12</i>	<i>MXM 3.0 Slave - Page B - 29</i>	<i>TouchPad LED Board - Page B - 46</i>
<i>MCP79 Power - Page B - 13</i>	<i>MB to Small B'd Connector A - Page B - 30</i>	<i>Front R Side LED Board - Page B - 47</i>
<i>MCP79 GND, RMGT PWR, PWRGD - Page B - 14</i>	<i>MB to Small B'd Connector B - Page B - 31</i>	<i>Front L Side LED Board - Page B - 48</i>
<i>DDR3 SO-DIMM_0 - Page B - 15</i>	<i>Power System - Page B - 32</i>	<i>Back L Side LED Board - Page B - 49</i>
<i>DDR SO-DIMM_1 - Page B - 16</i>	<i>Power VCore - Page B - 33</i>	<i>Touch Sensor Board A - Page B - 50</i>
<i>Panel, Inverter, TPM - Page B - 17</i>	<i>PWR 1.05V, Screw Hole - Page B - 34</i>	<i>Touch Sensor Board B - Page B - 51</i>
<i>HDMI, Fan Control - Page B - 18</i>	<i>Power 1.5V/0.75V - Page B - 35</i>	<i>CIR Board - Page B - 52</i>

Table B - 1
**Schematic
Diagrams**



Version Note

The schematic diagrams in this chapter are based upon version 6-7P-M980F-002. If your mainboard (or other boards) are a later version, please check with the Service Center for updated diagrams (if required).

System Block Diagram

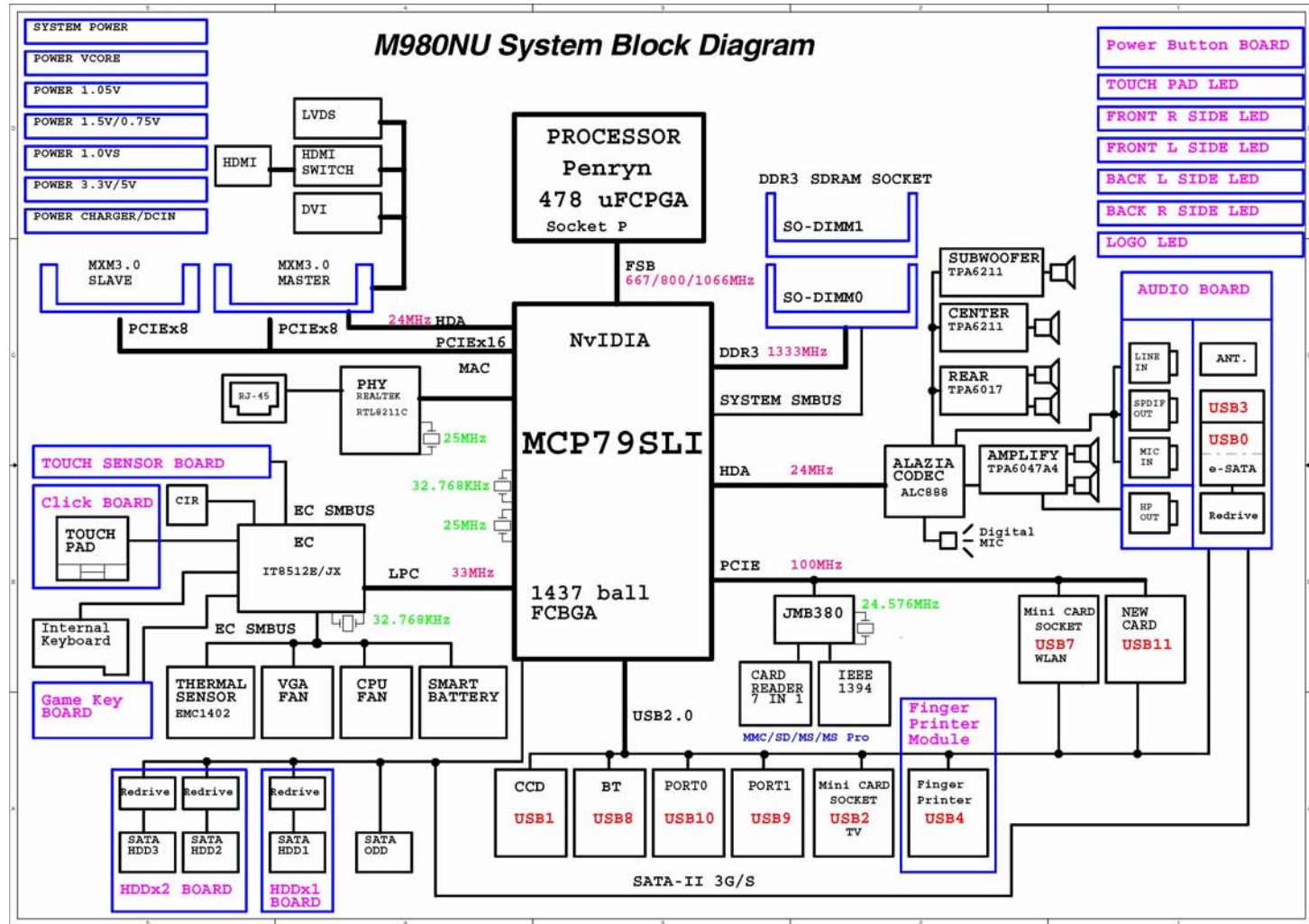

Sheet 1 of 53
System Block
Diagram

PENRYN3 2/2

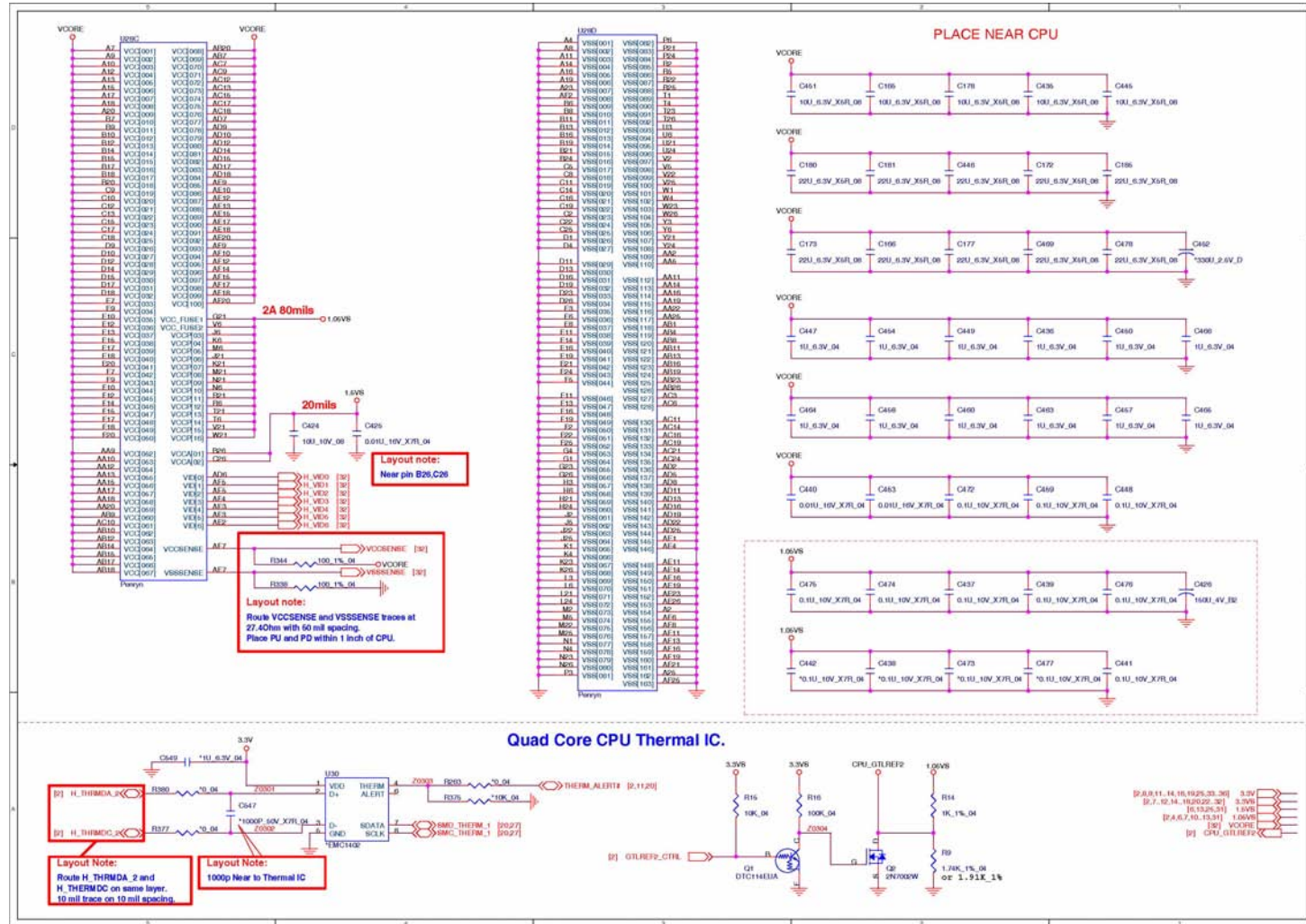

Sheet 3 of 53
PENRYN 2/2

B.Schematic Diagrams

MCP79 MEM CTRL (1)

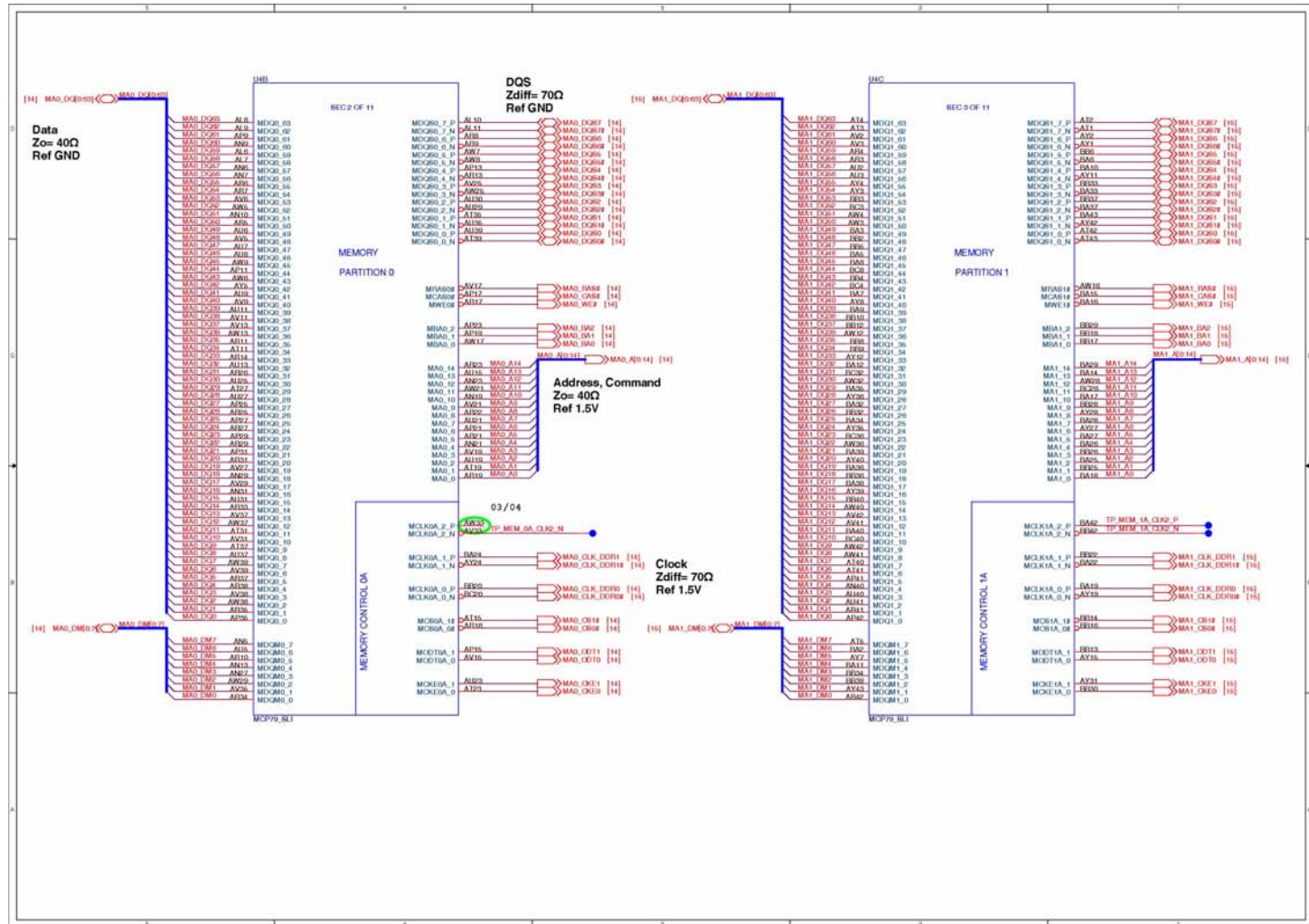

B.Schematic Diagrams

Sheet 5 of 53
MCP79 MEM CTRL
(1)

MCP79 PCI-E

Sheet 7 of 53
MCP79 PCI-E

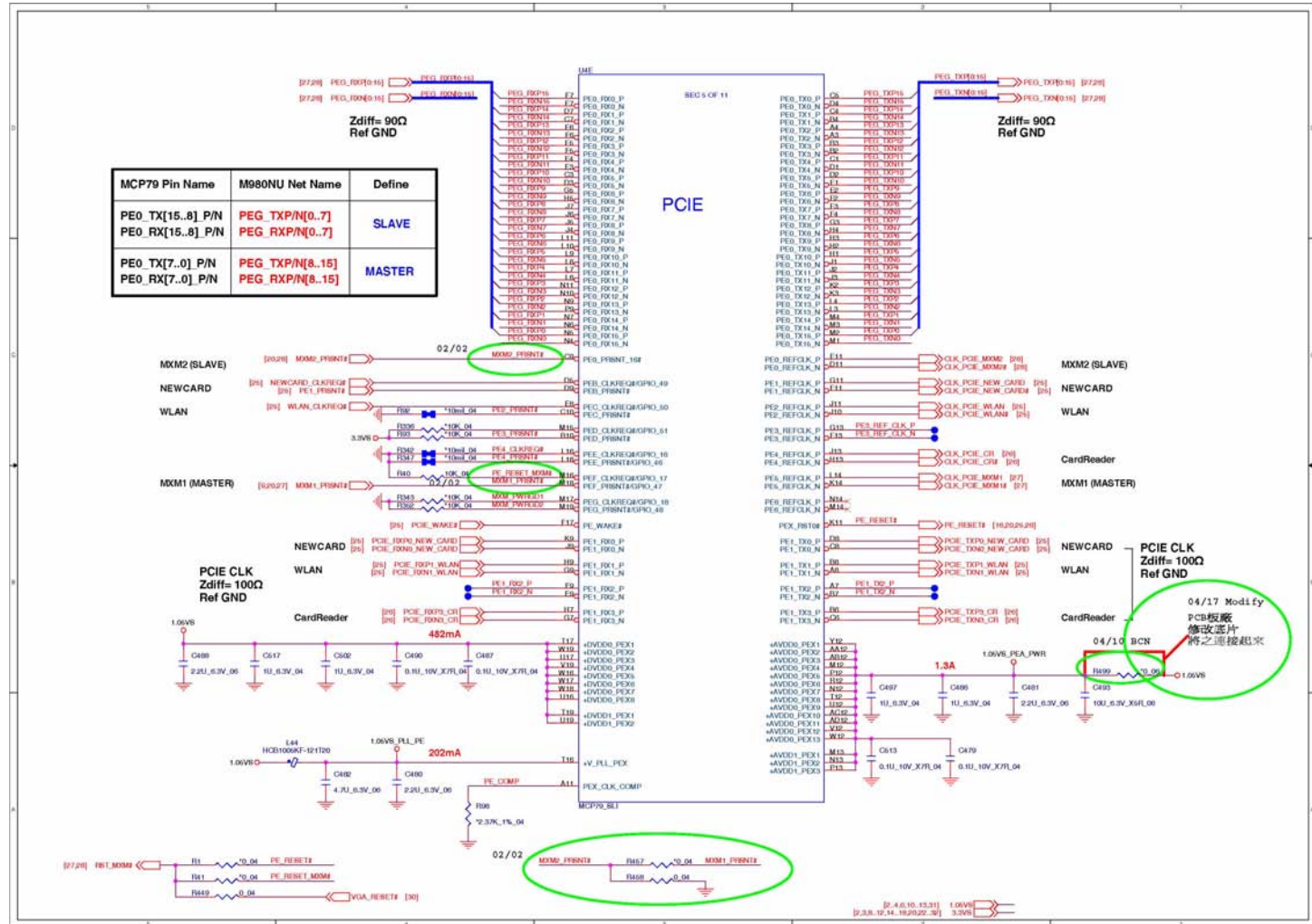

MCP79 LAN, Panel

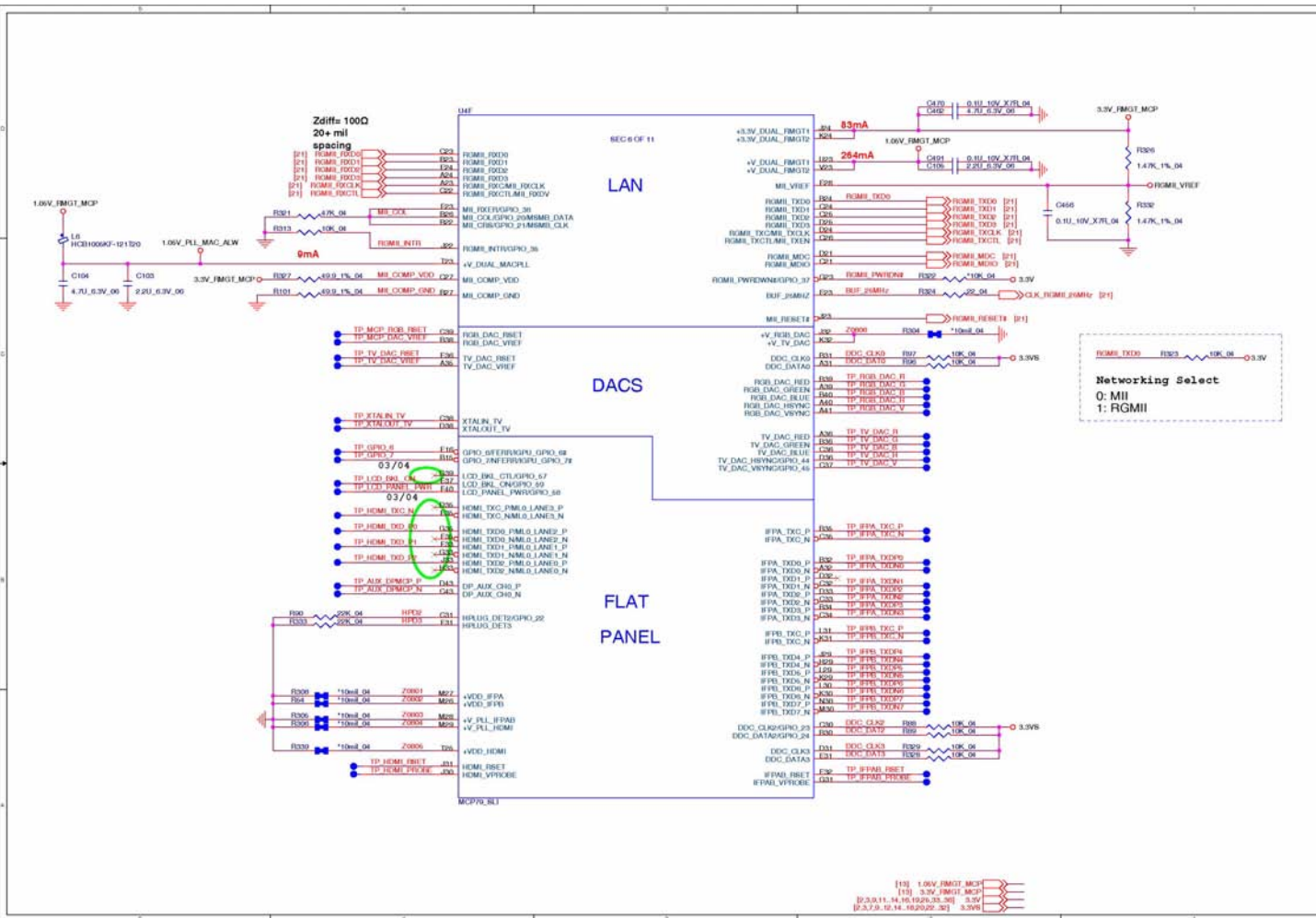

Sheet 8 of 53
MCP79 LAN, Panel

MCP79 Power

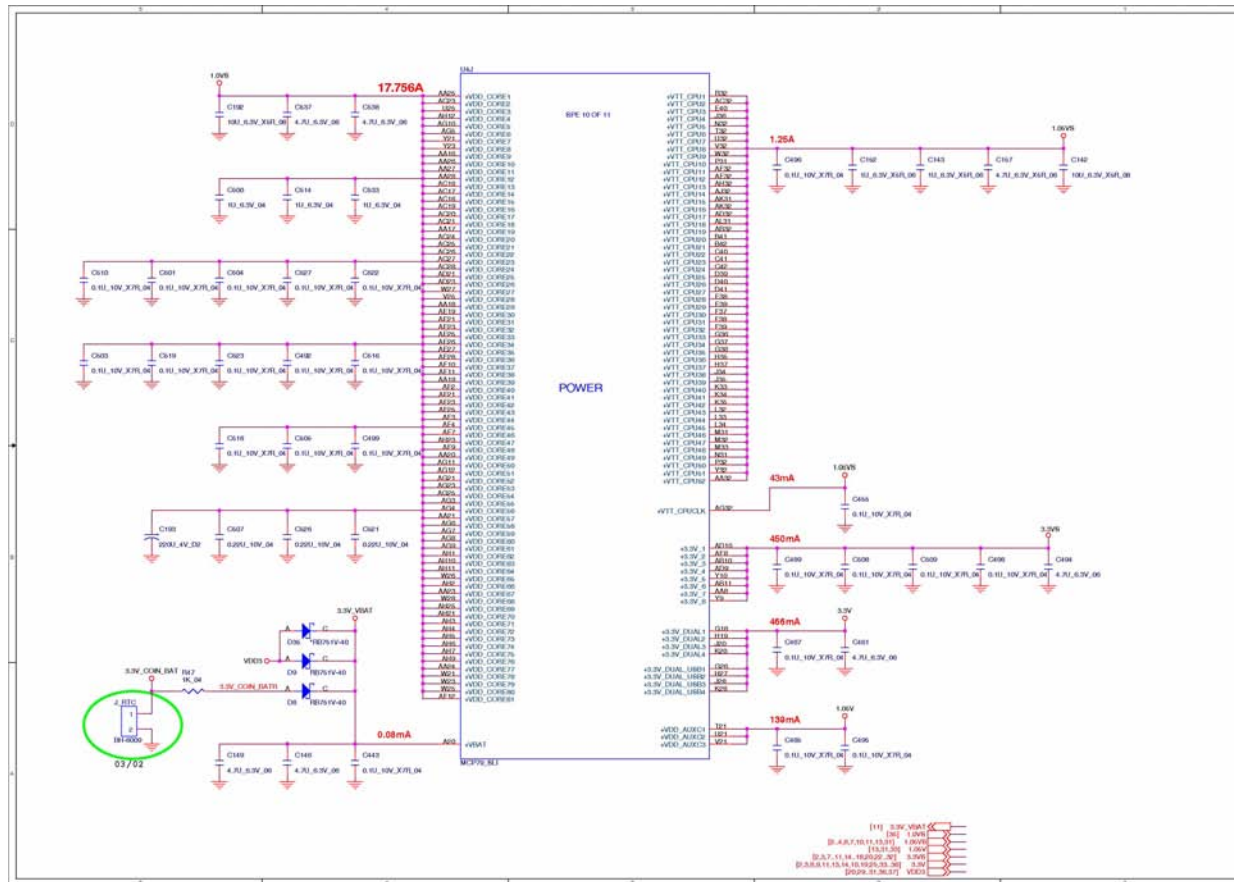

Sheet 12 of 53
MCP79 Power

B. Schematic Diagrams

DDR3 SO-DIMM_0

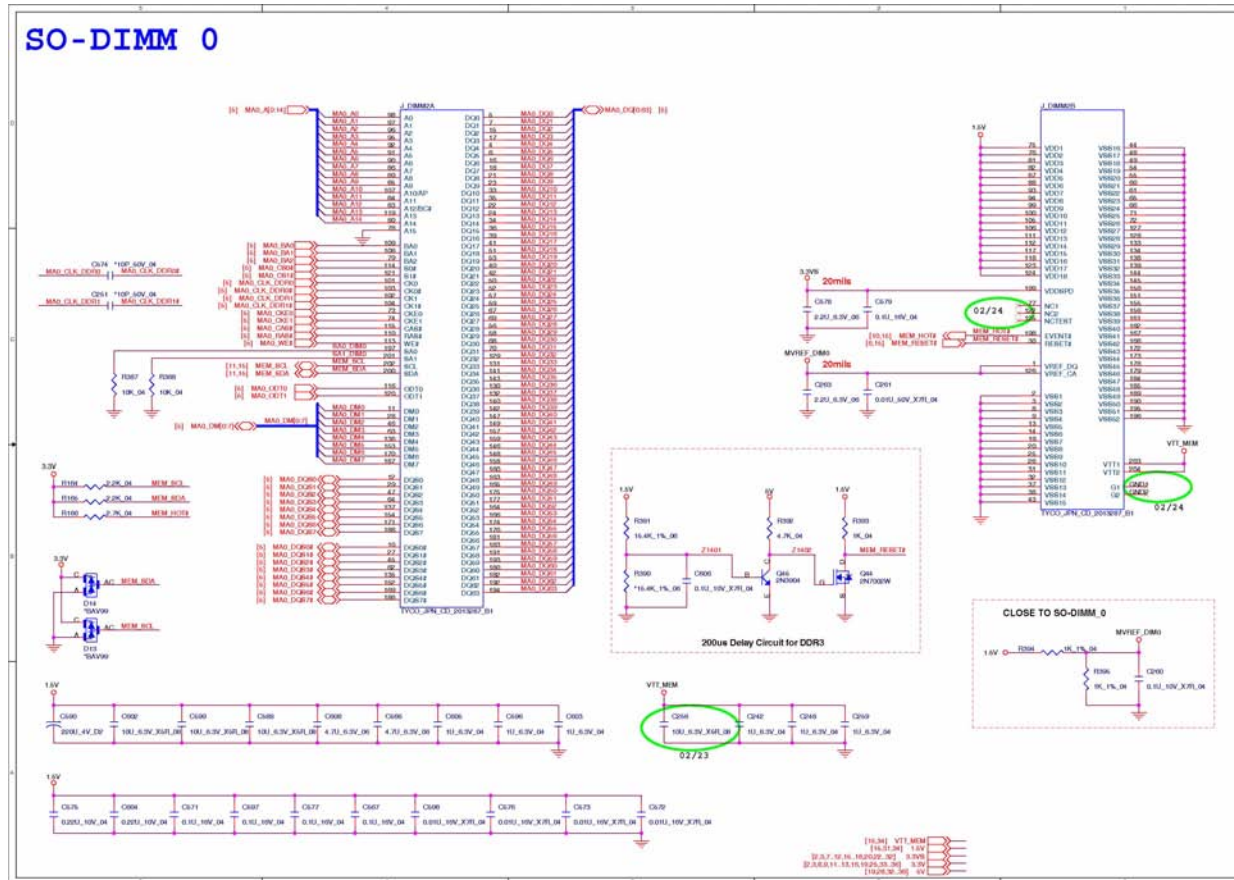

Sheet 14 of 53
DDR3 SO-DIMM_0

B. Schematic Diagrams

HDMI, Fan Control

Sheet 17 of 53
HDMI, Fan Control

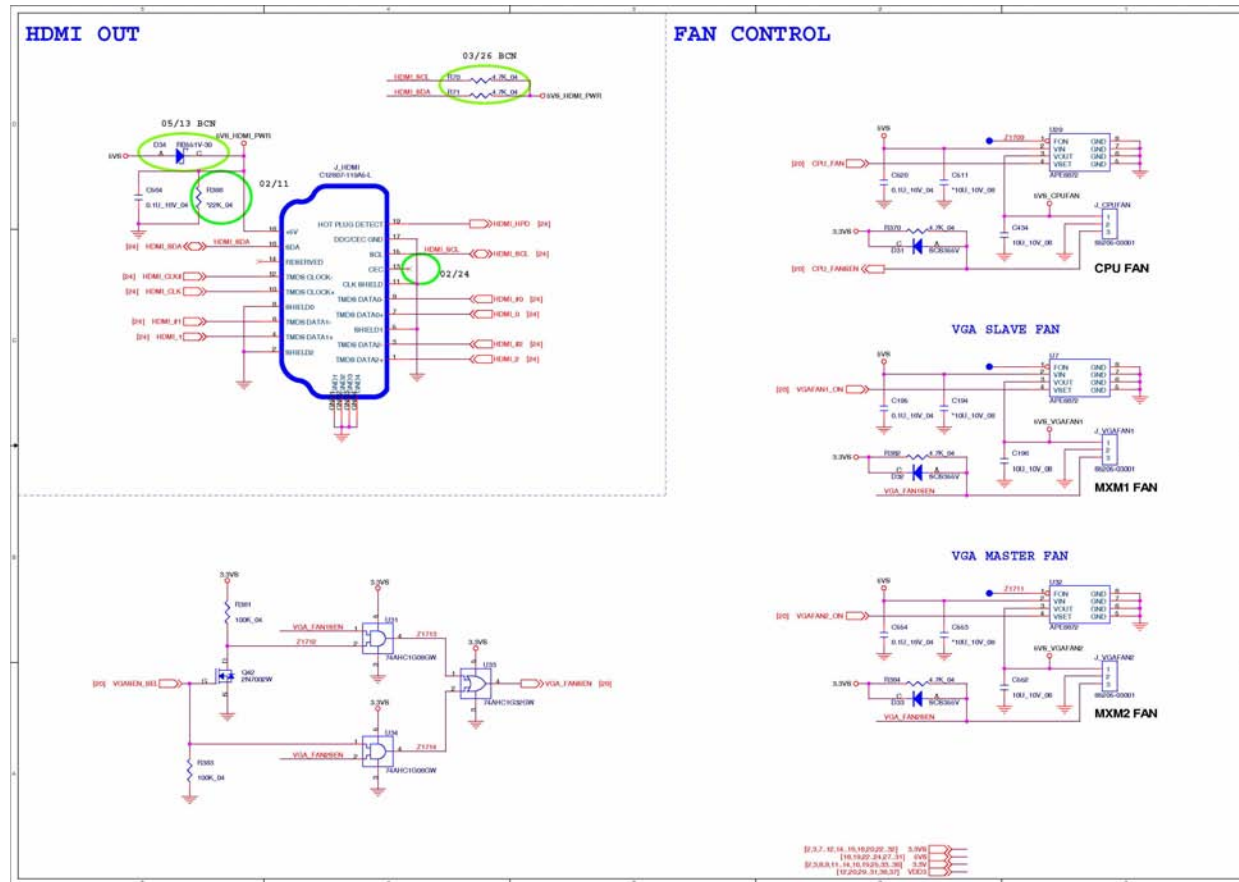

CRT, DVI

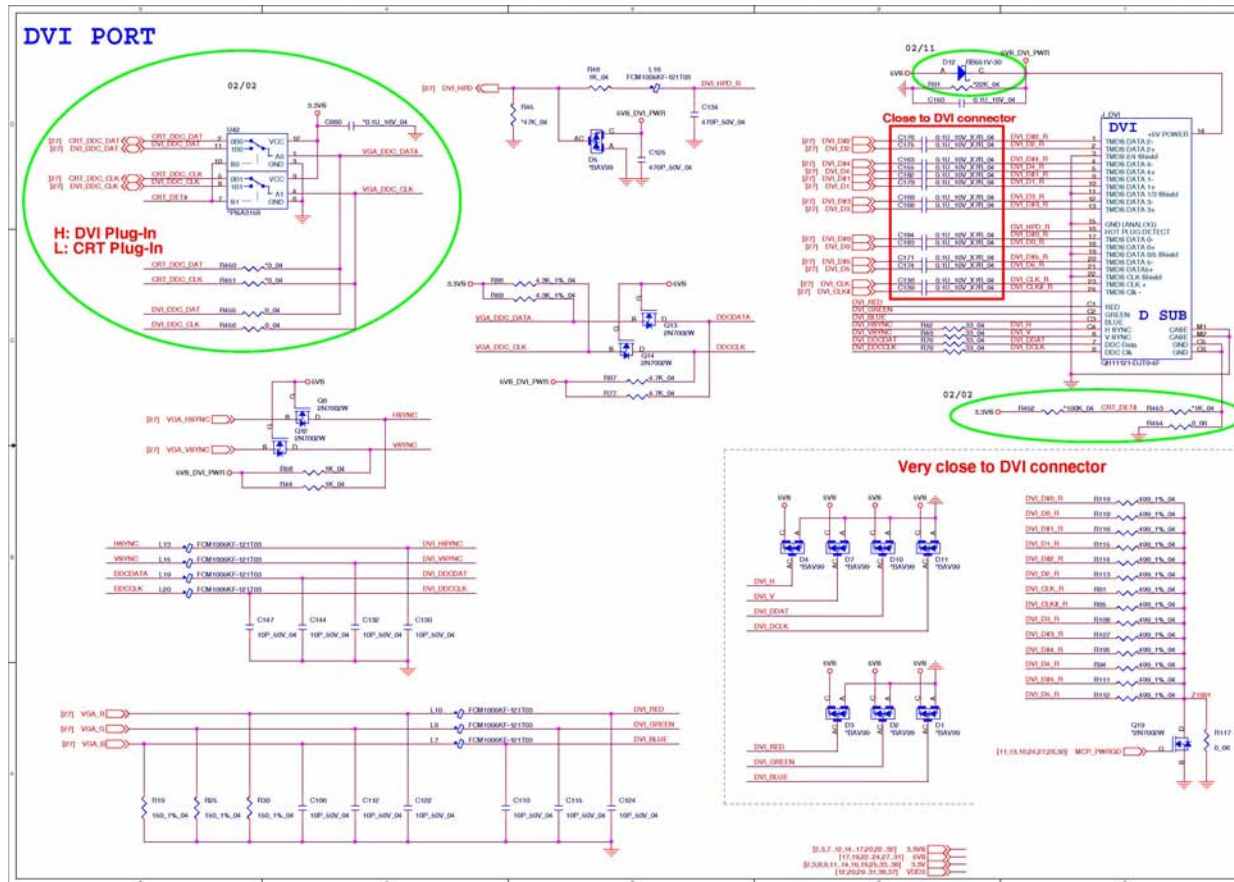

ODD, CCD, BT, USB 2.0

Sheet 19 of 53
ODD, CCD, BT,
USB 2.0

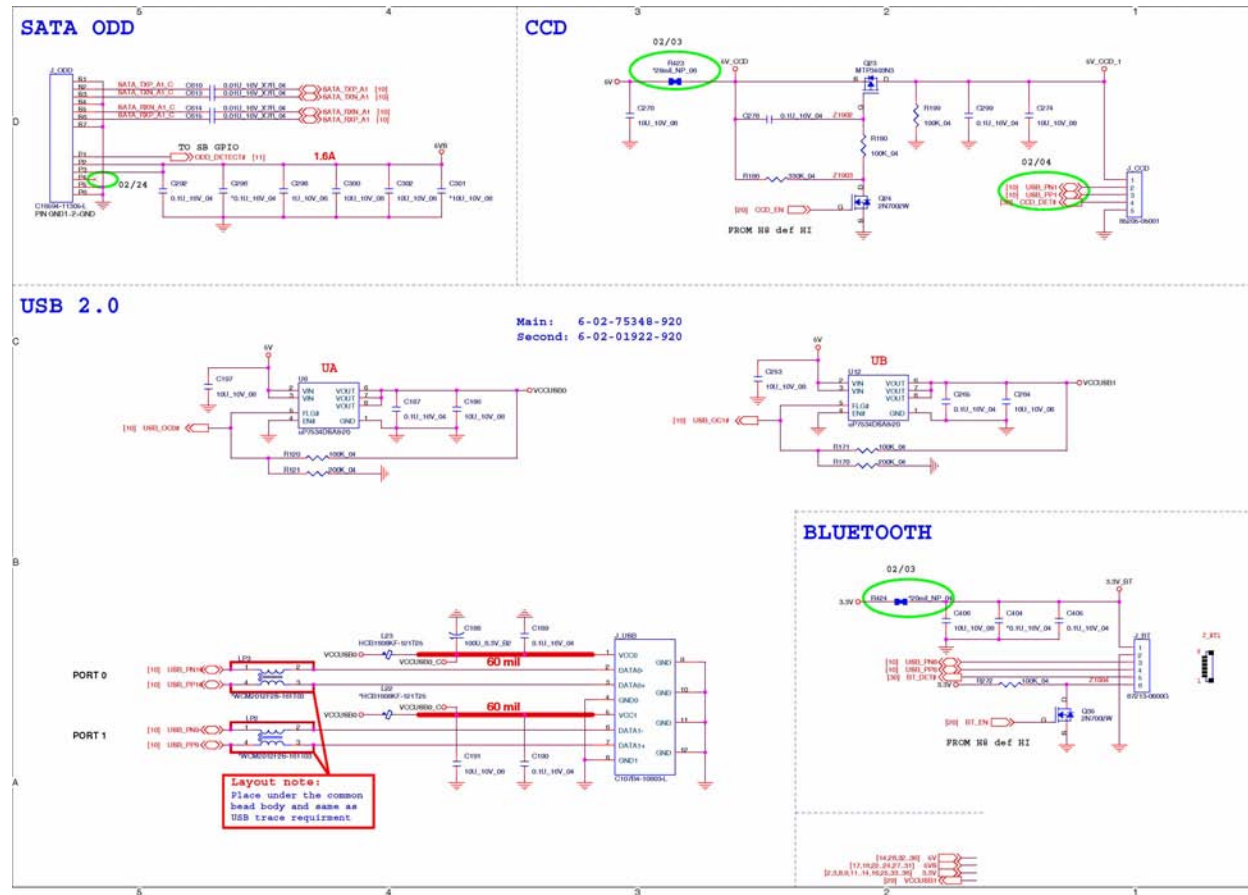

KBC ITE IT8512-J

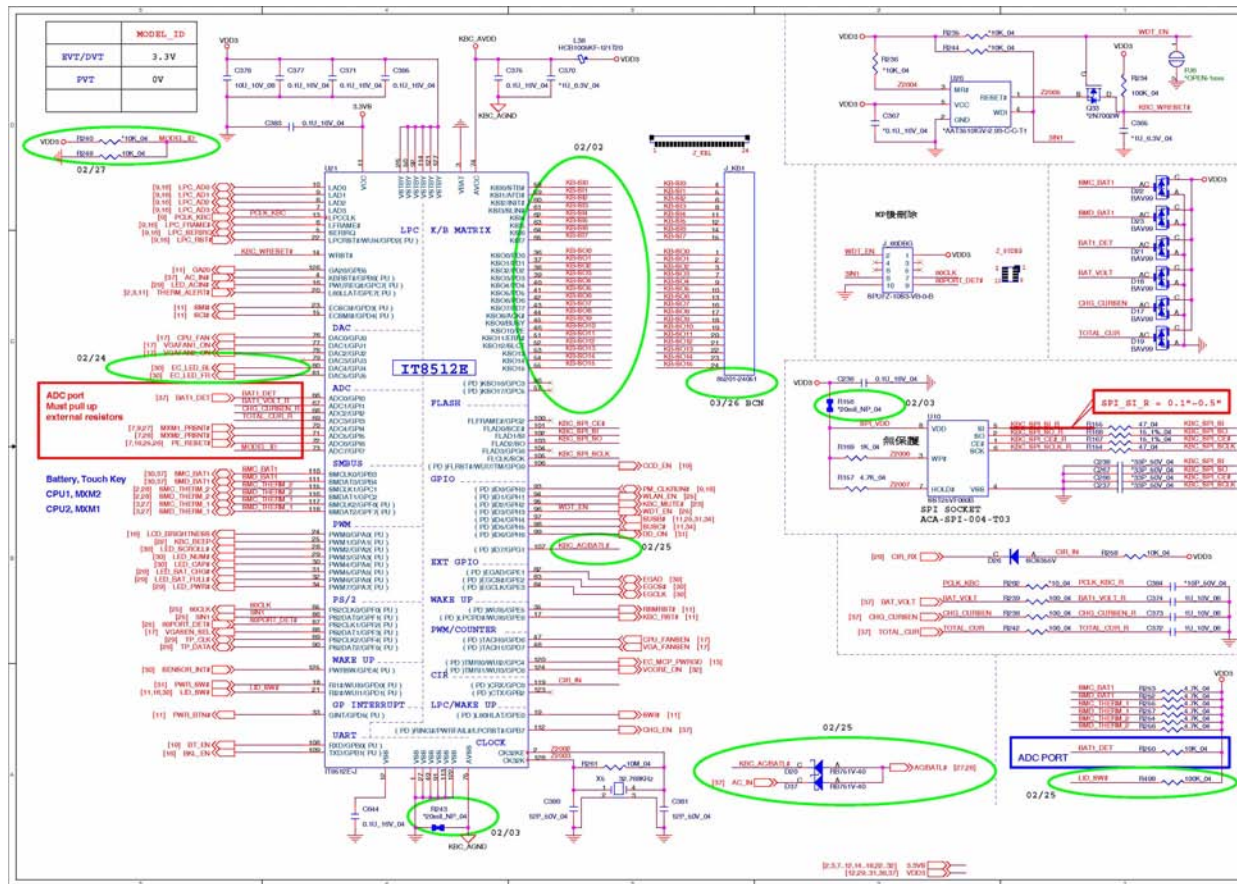

Sheet 20 of 53
KBC ITE IT8512-J

Codec, Subwoofer, DMIC

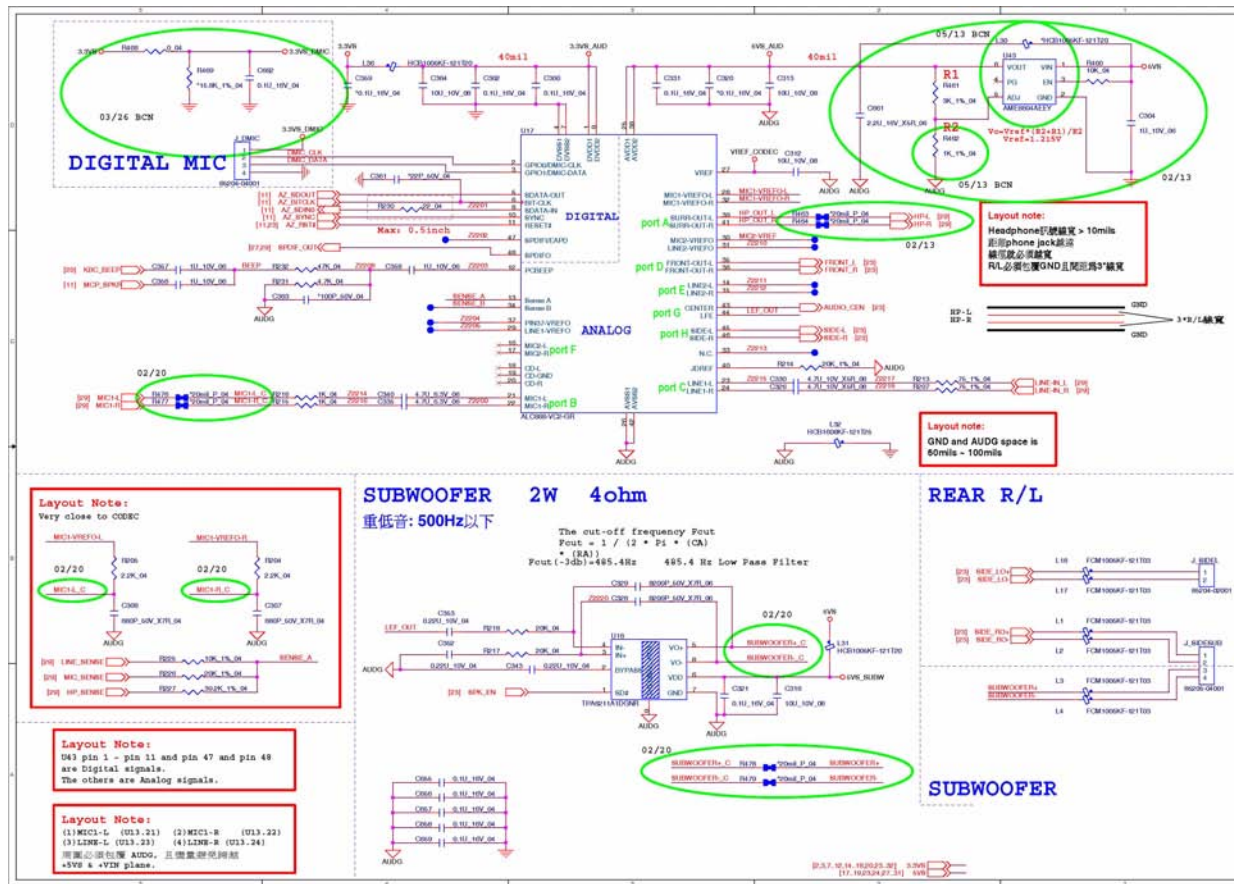

B.Schematic Diagrams

Sheet 22 of 53
Codec, Subwoofer,
DMIC

Audio AMP

Sheet 23 of 53
Audio AMP

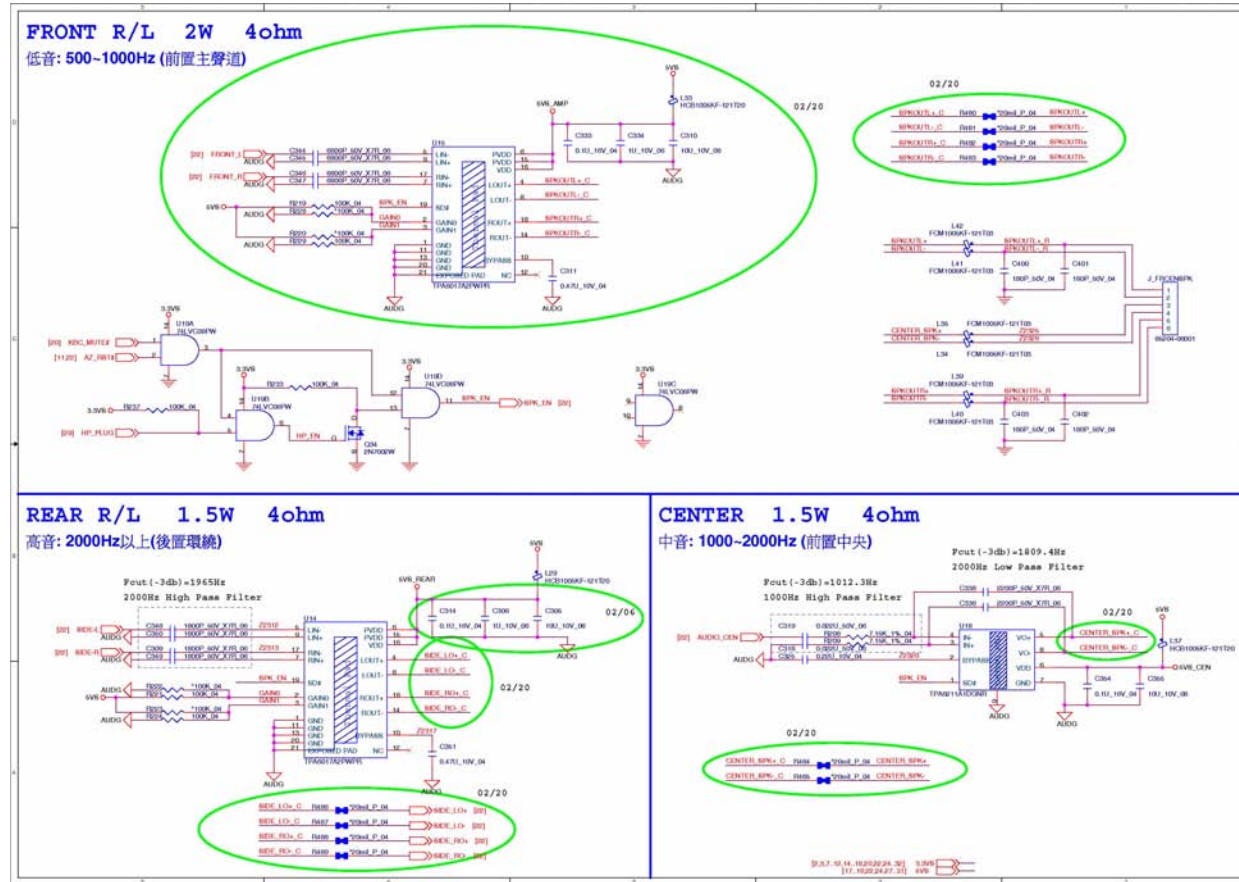

New Card, Mini Card

Sheet 25 of 53
New Card, Mini Card

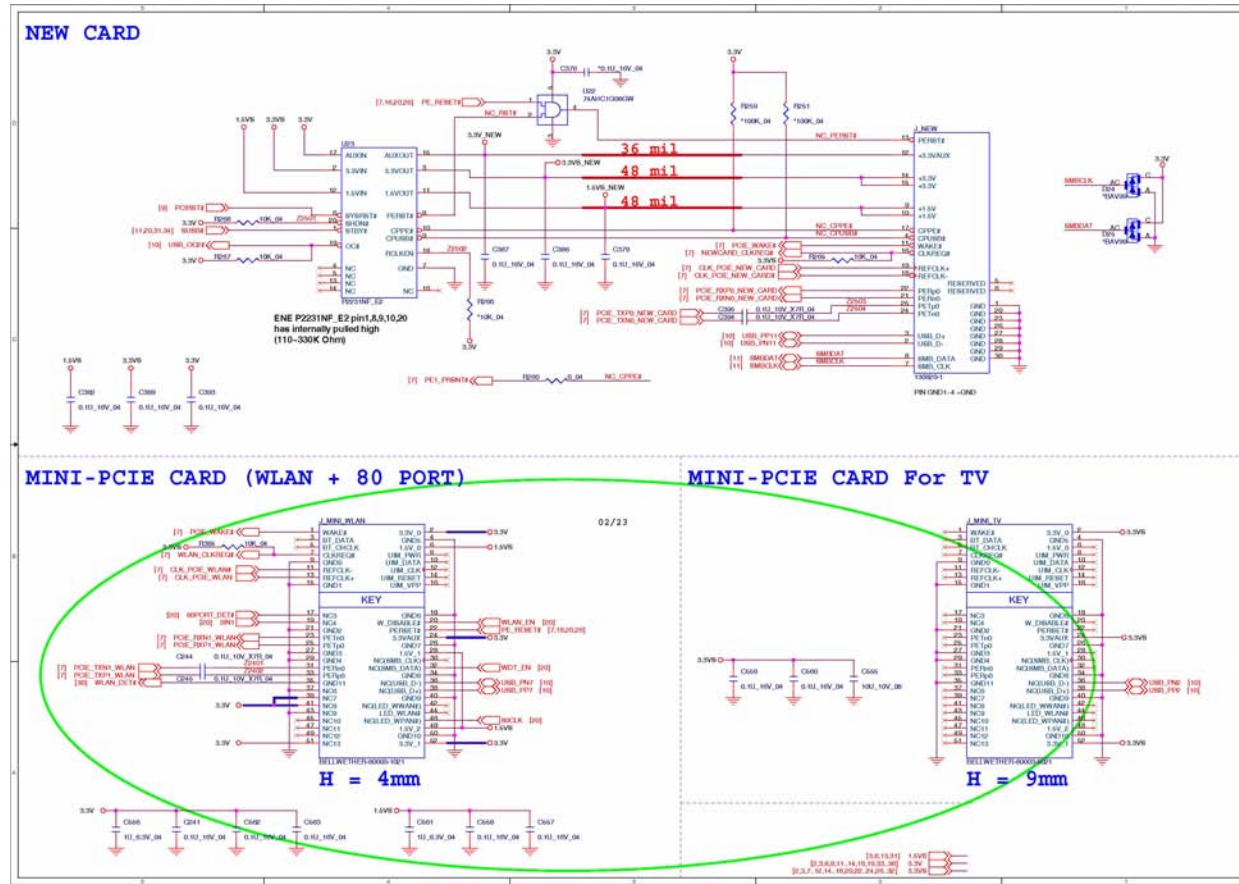

MXM 3.0 Master

Sheet 27 of 53
MXM 3.0 Master

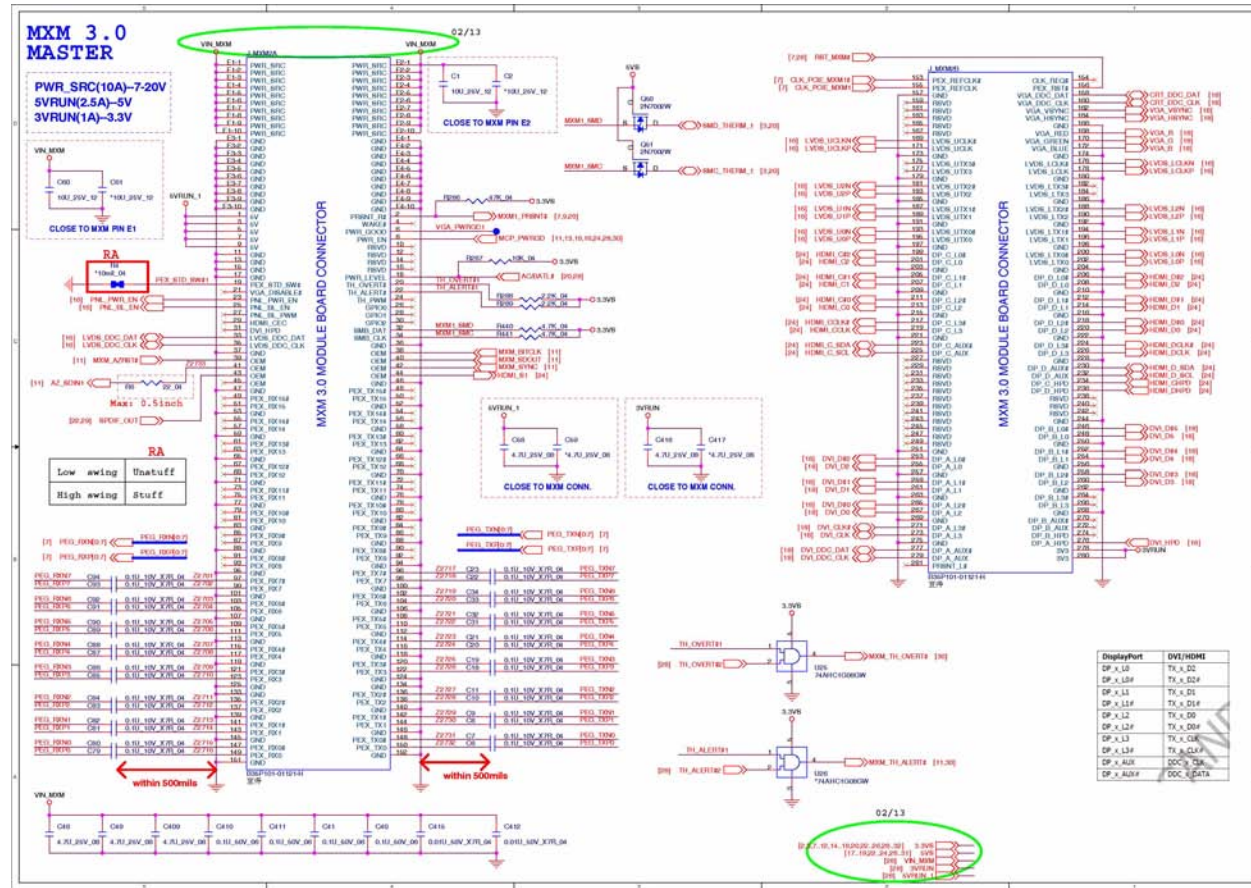

MB to Small B'd Connector A

Sheet 29 of 53
MB to Small B'd
Connector A

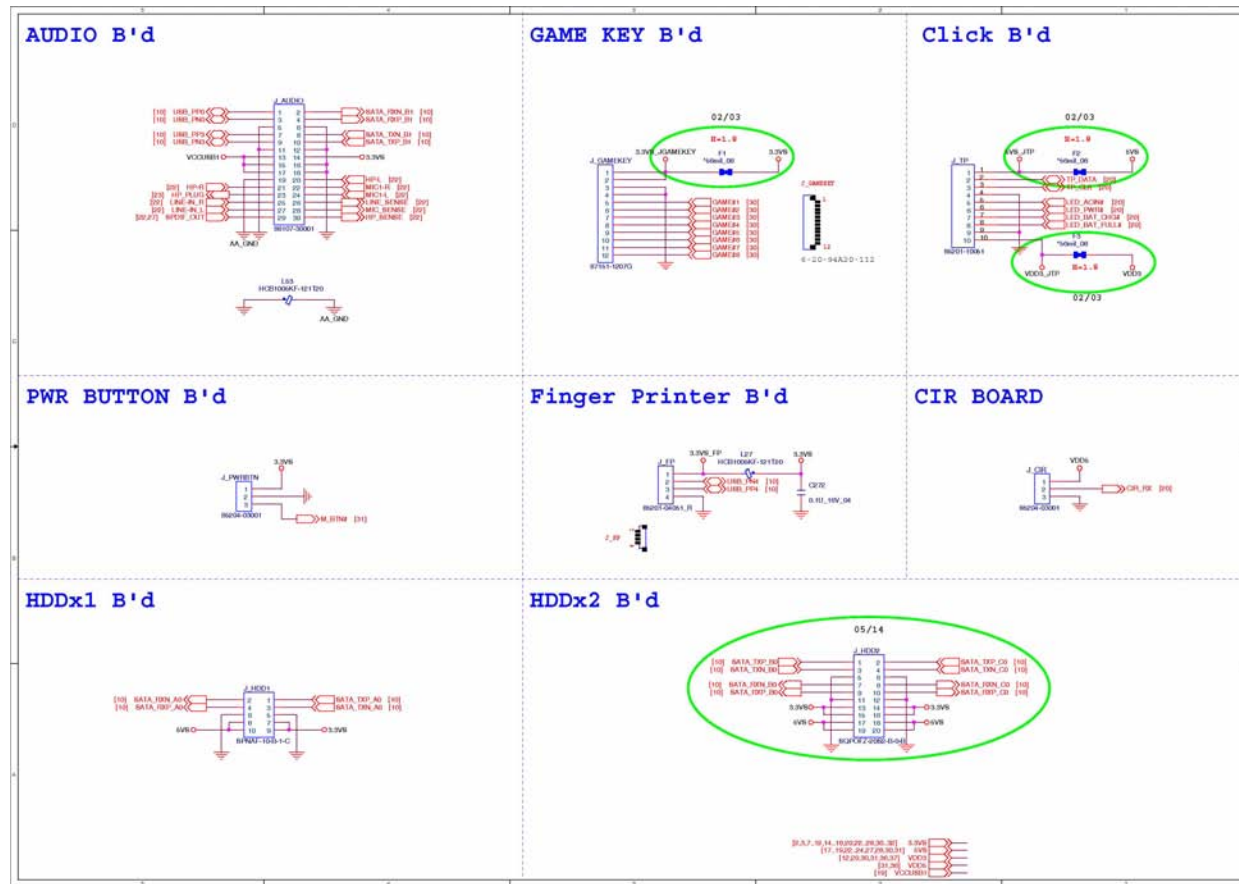

MB to Small B'd Connector B

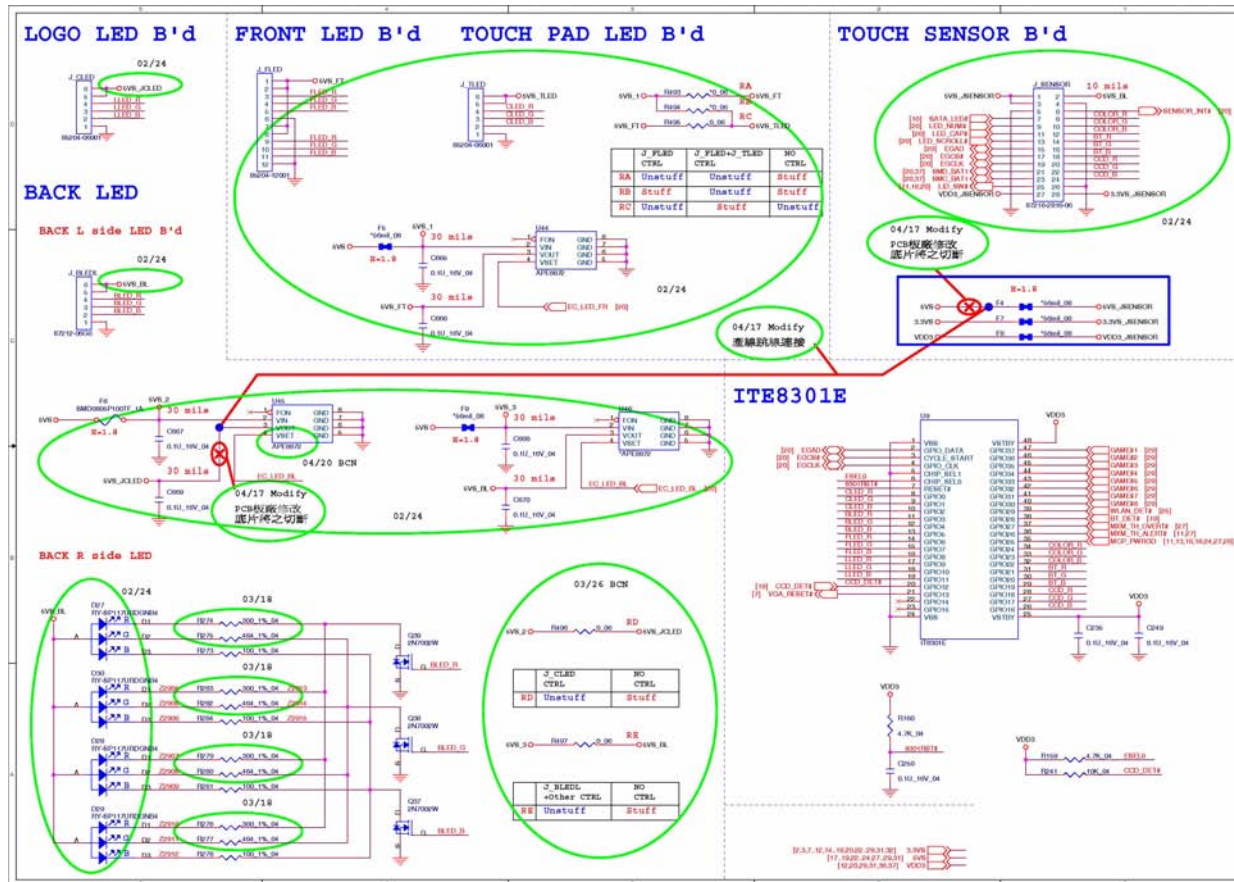

Sheet 30 of 53
MB to Small B'd
Connector B

Power System

Sheet 31 of 53
Power System

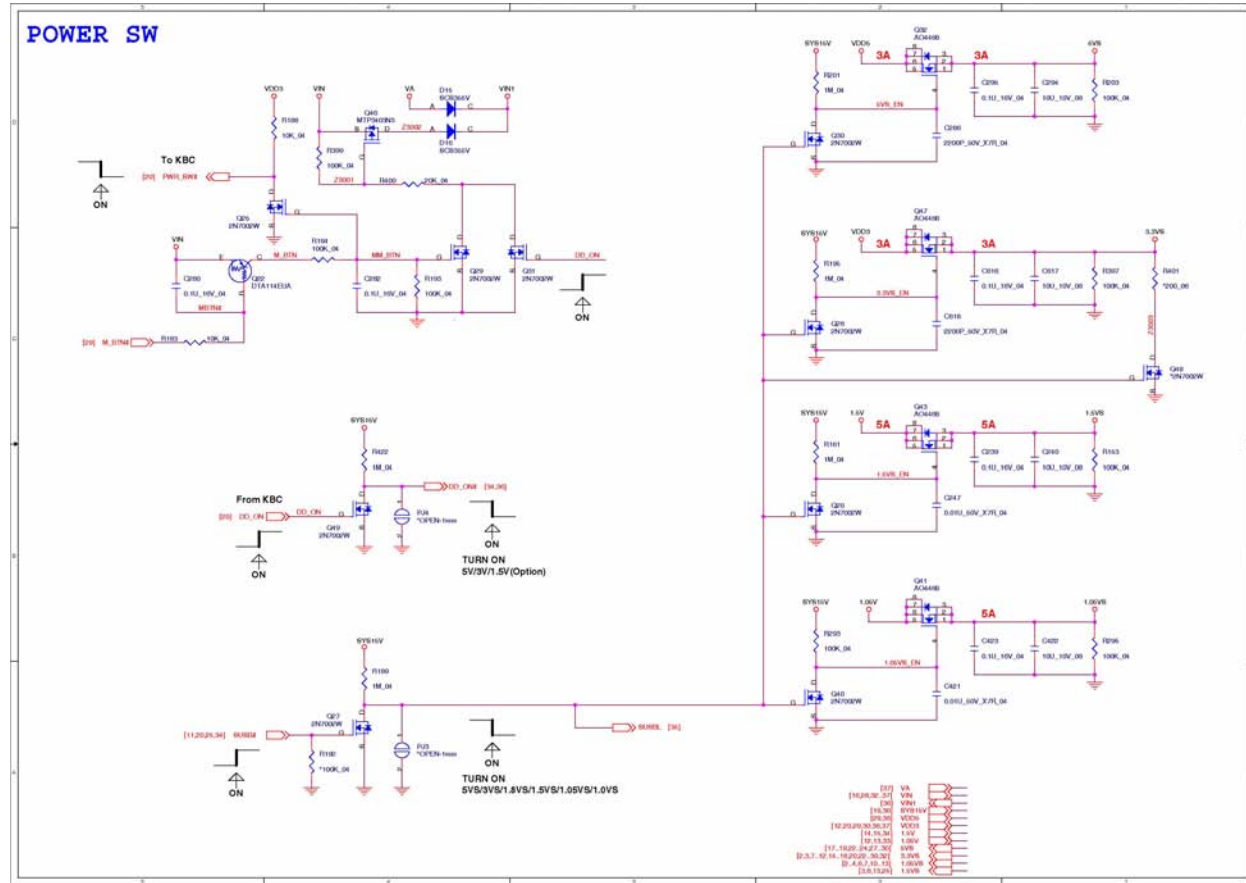

Power VCore

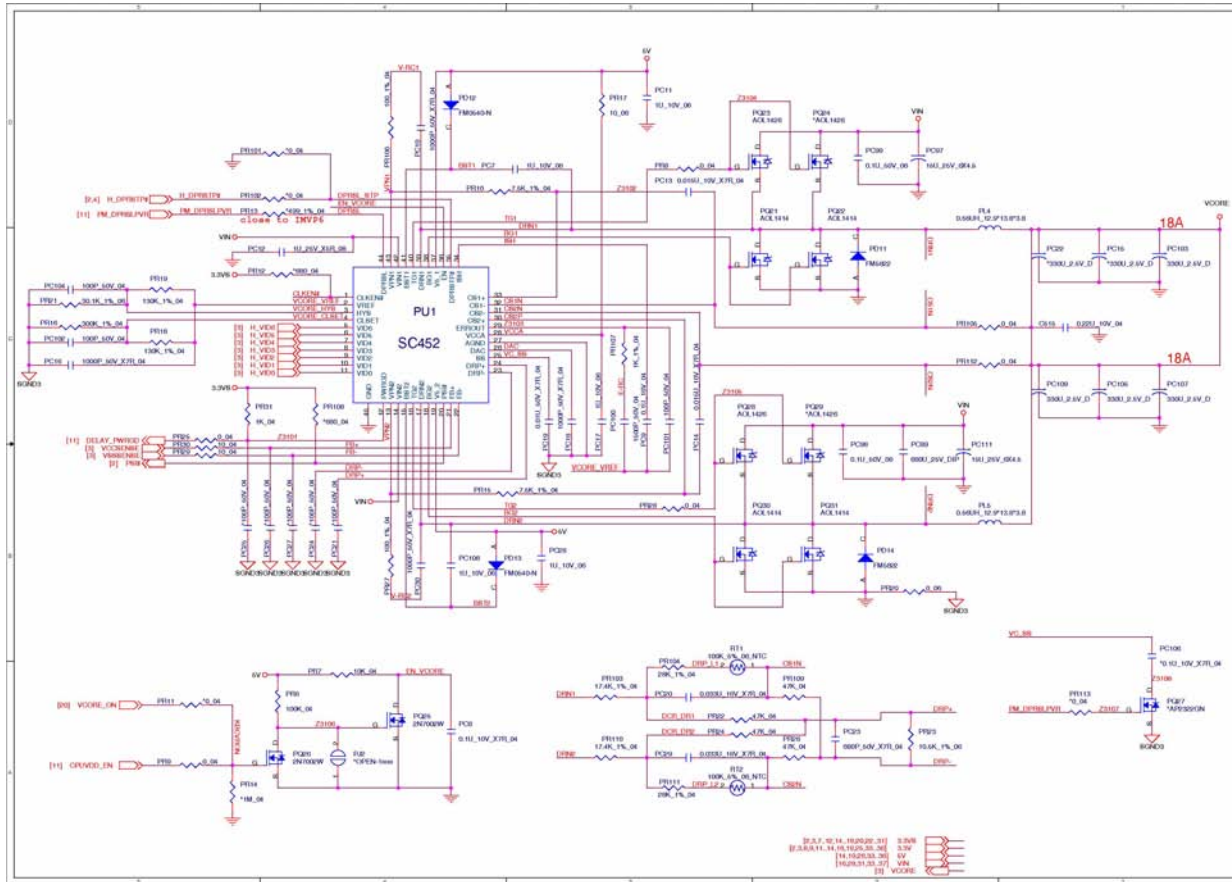

Sheet 32 of 53
Power VCore

Power 3.3V/5V

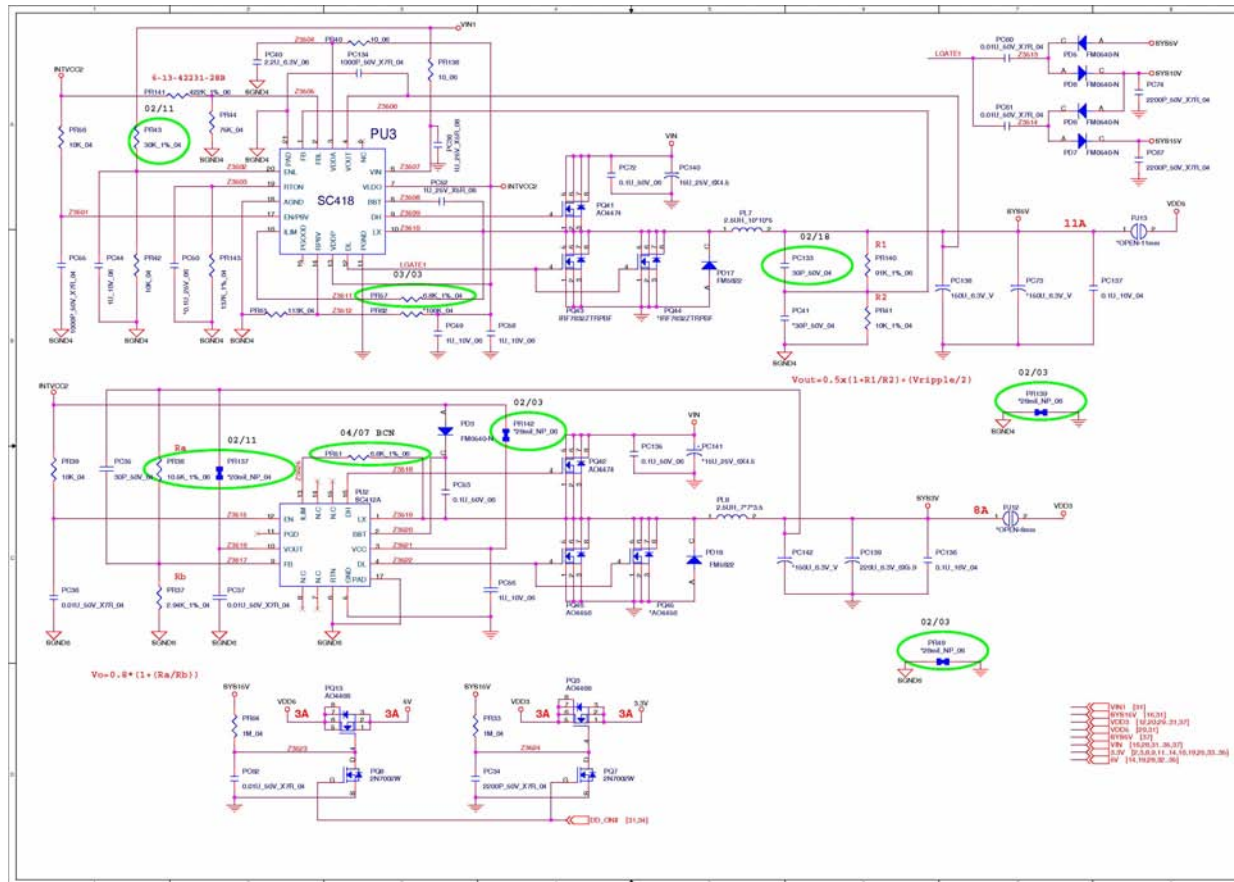

Sheet 36 of 53
Power 3.3V/5V

B. Schematic Diagrams

Schematic Diagrams

Power Charger, DC-In

B.Schematic Diagrams

Sheet 37 of 53
Power Charger,
DC-In

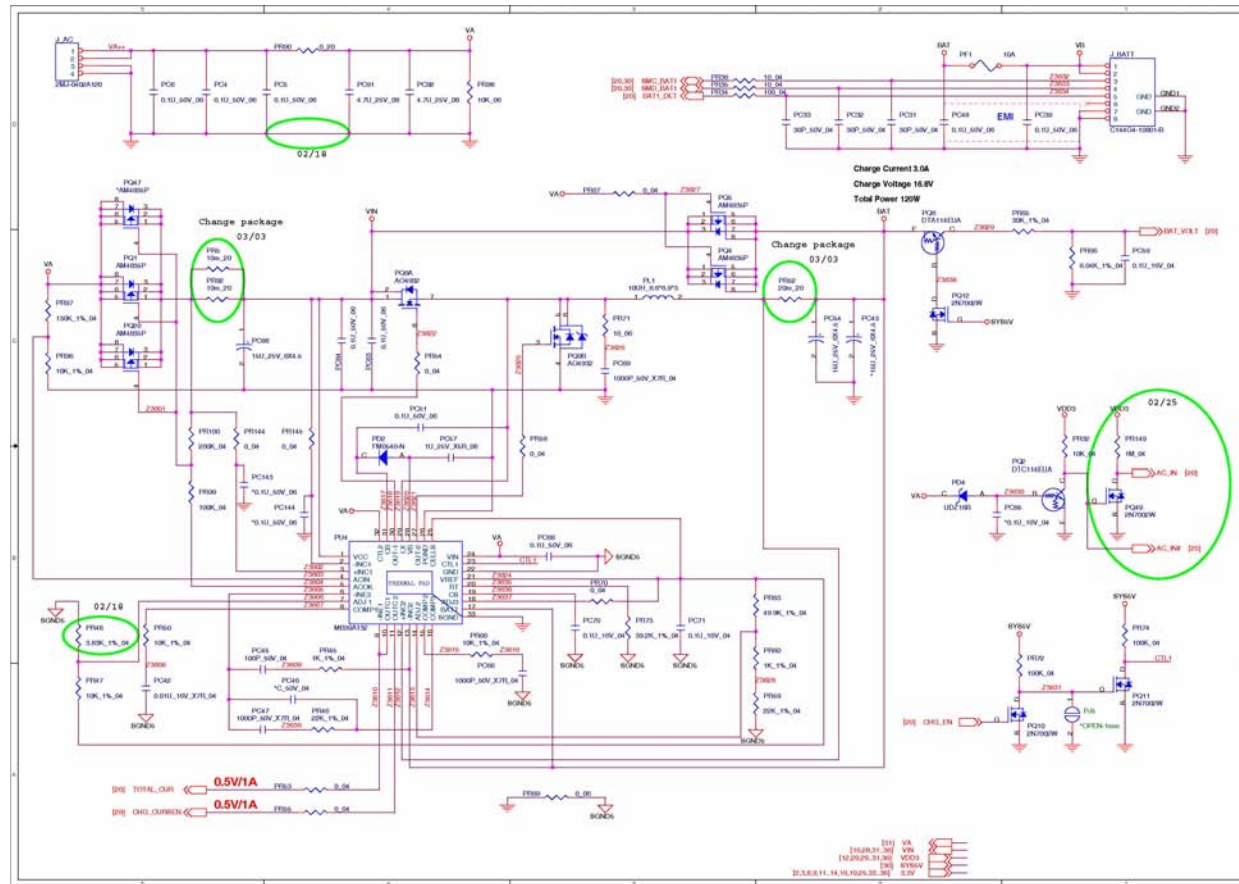

Single HDD Board

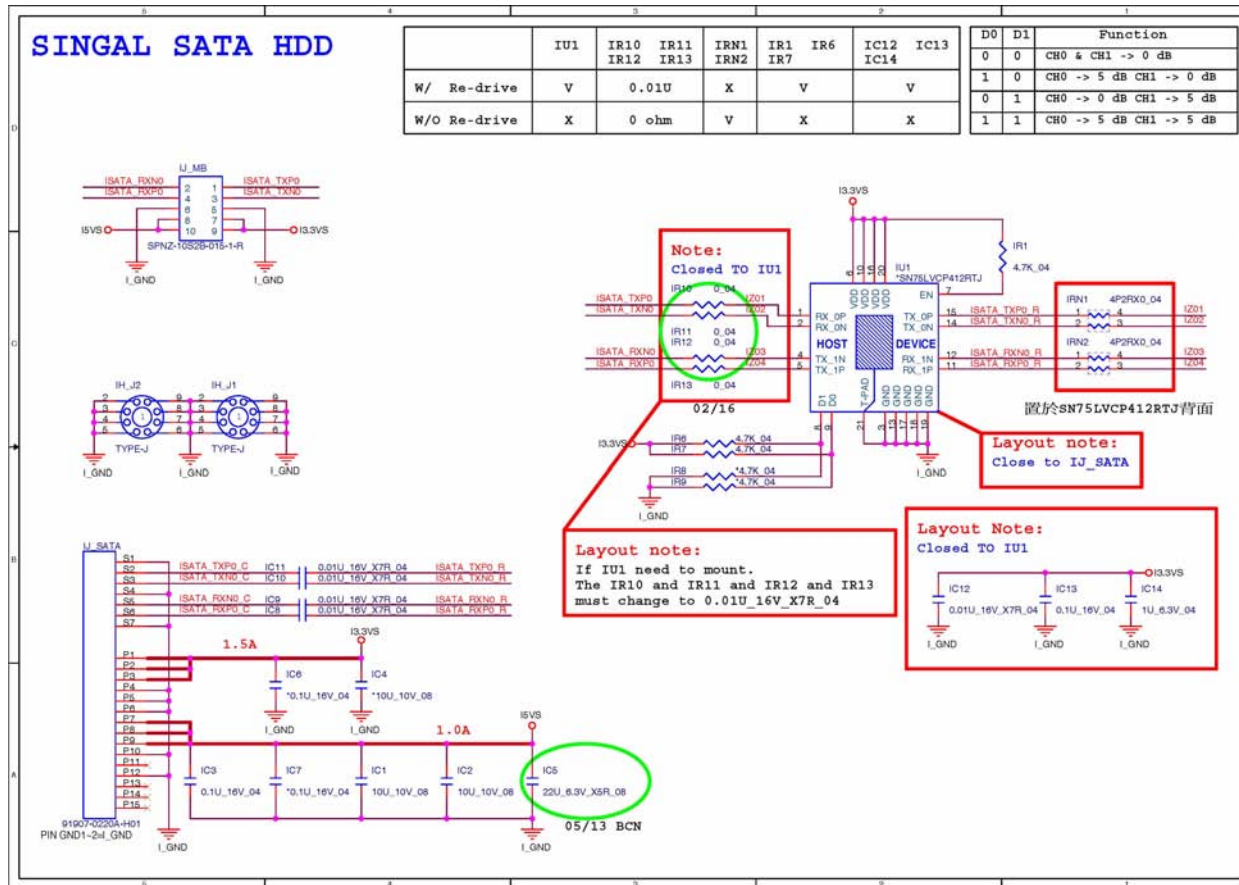

Sheet 38 of 53
Single HDD Board

Dual HDD Board

Sheet 39 of 53
Dual HDD Board

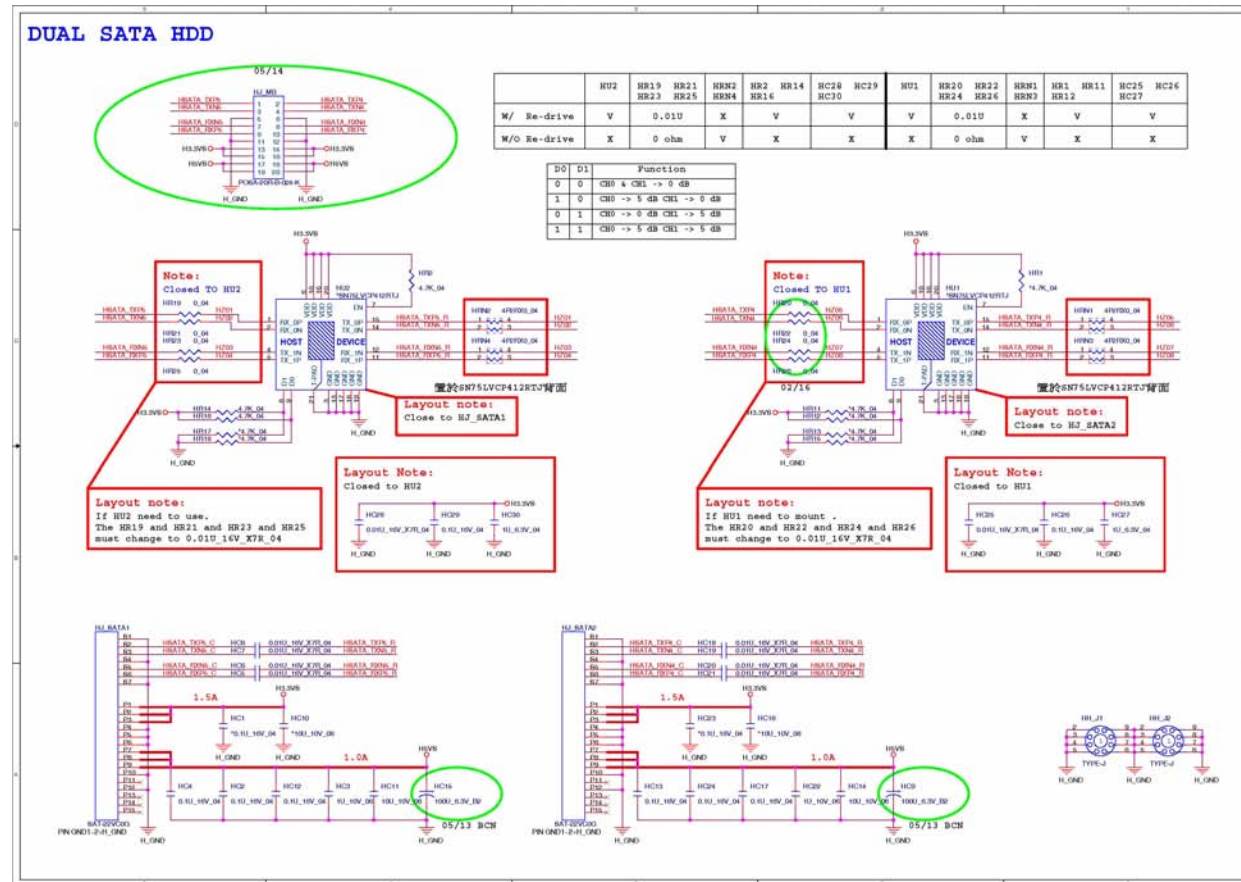

Audio Board

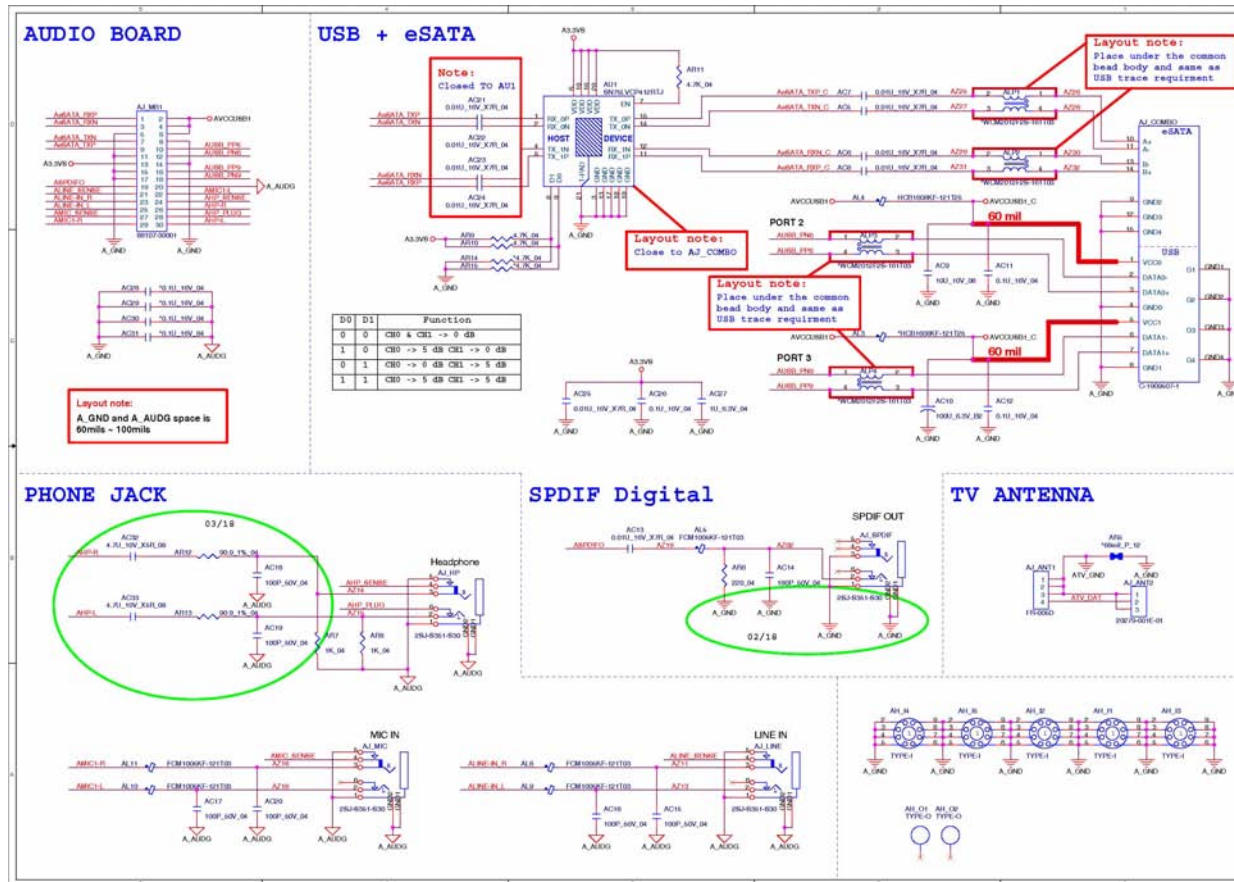

Sheet 40 of 53
Audio Board

Power Button Board

Sheet 41 of 53
Power Button
Board

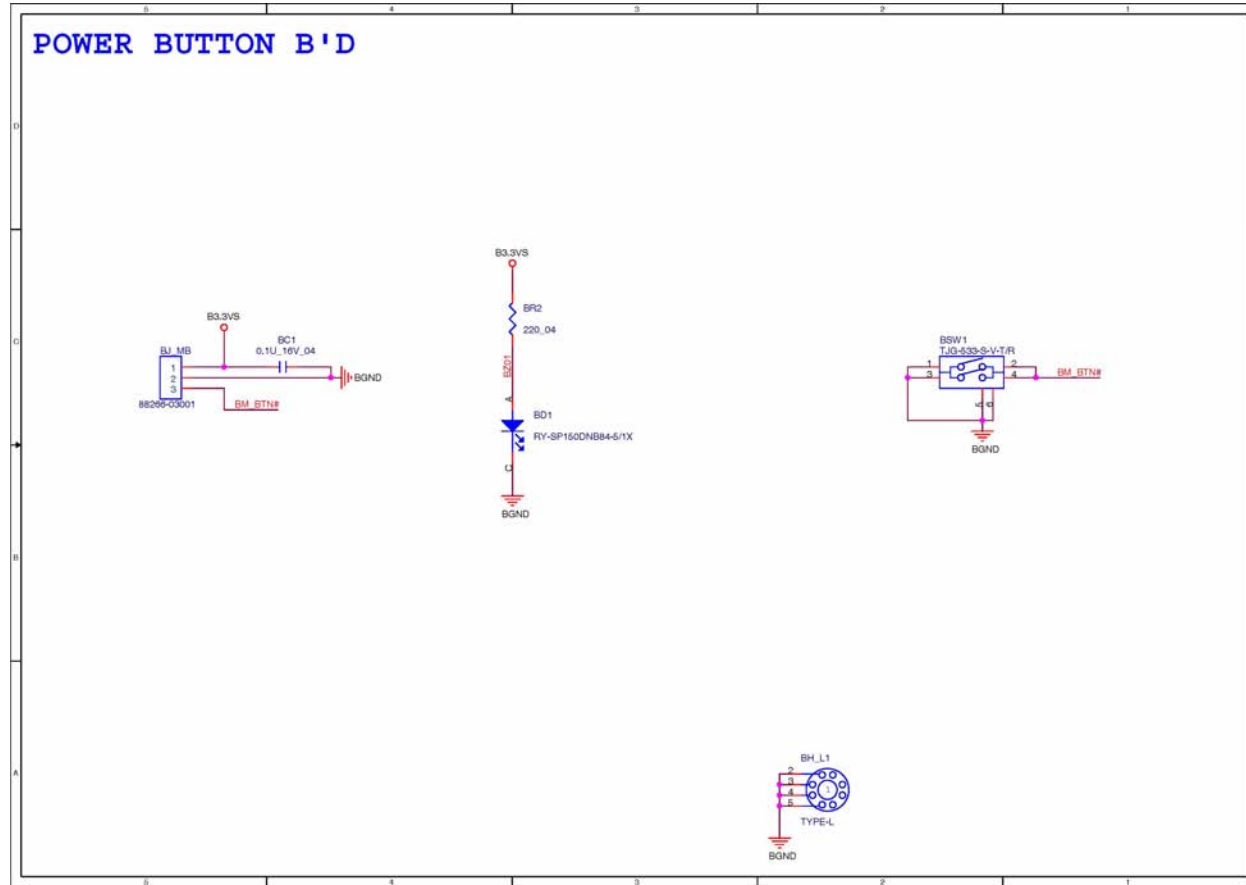

Schematic Diagrams

Logo LED Board

Sheet 43 of 53
Logo LED Board

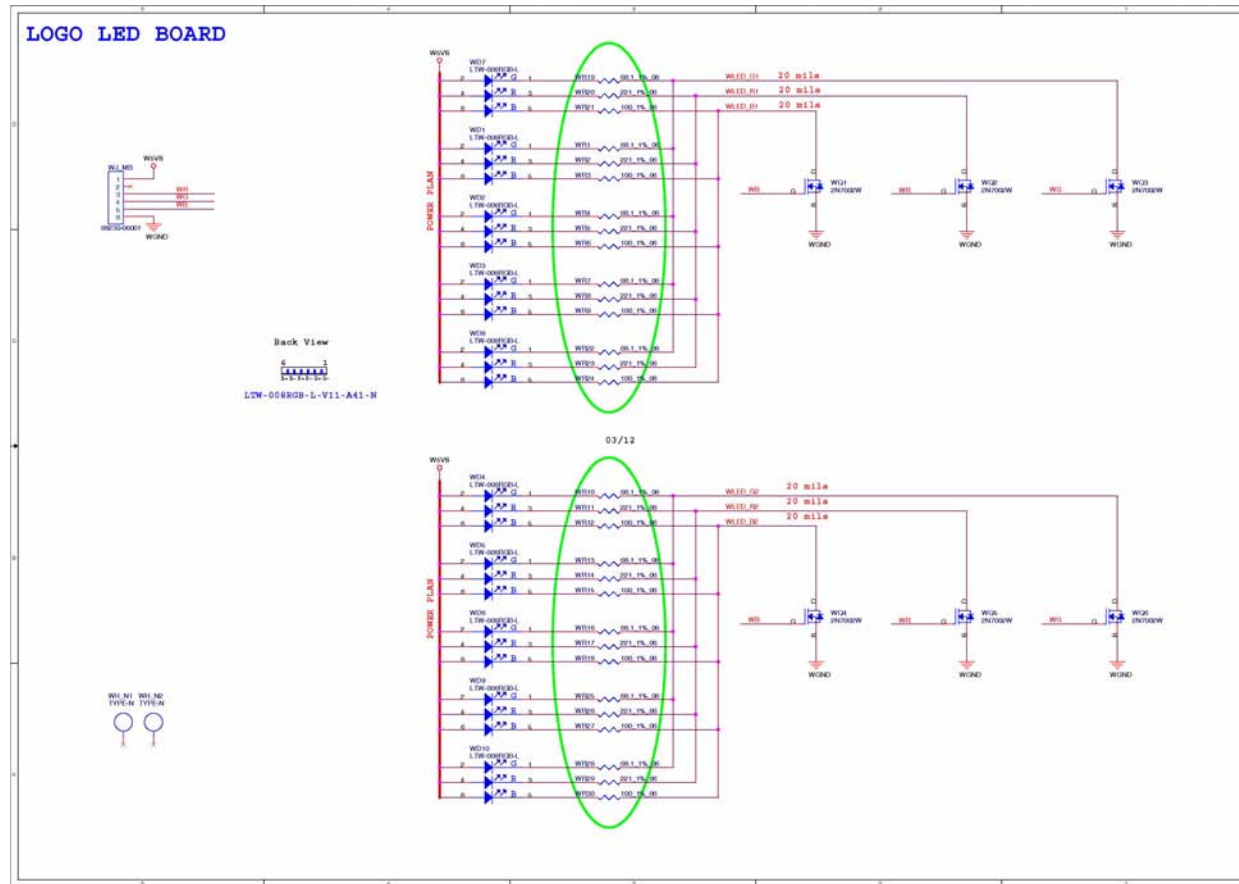

Game Key Board

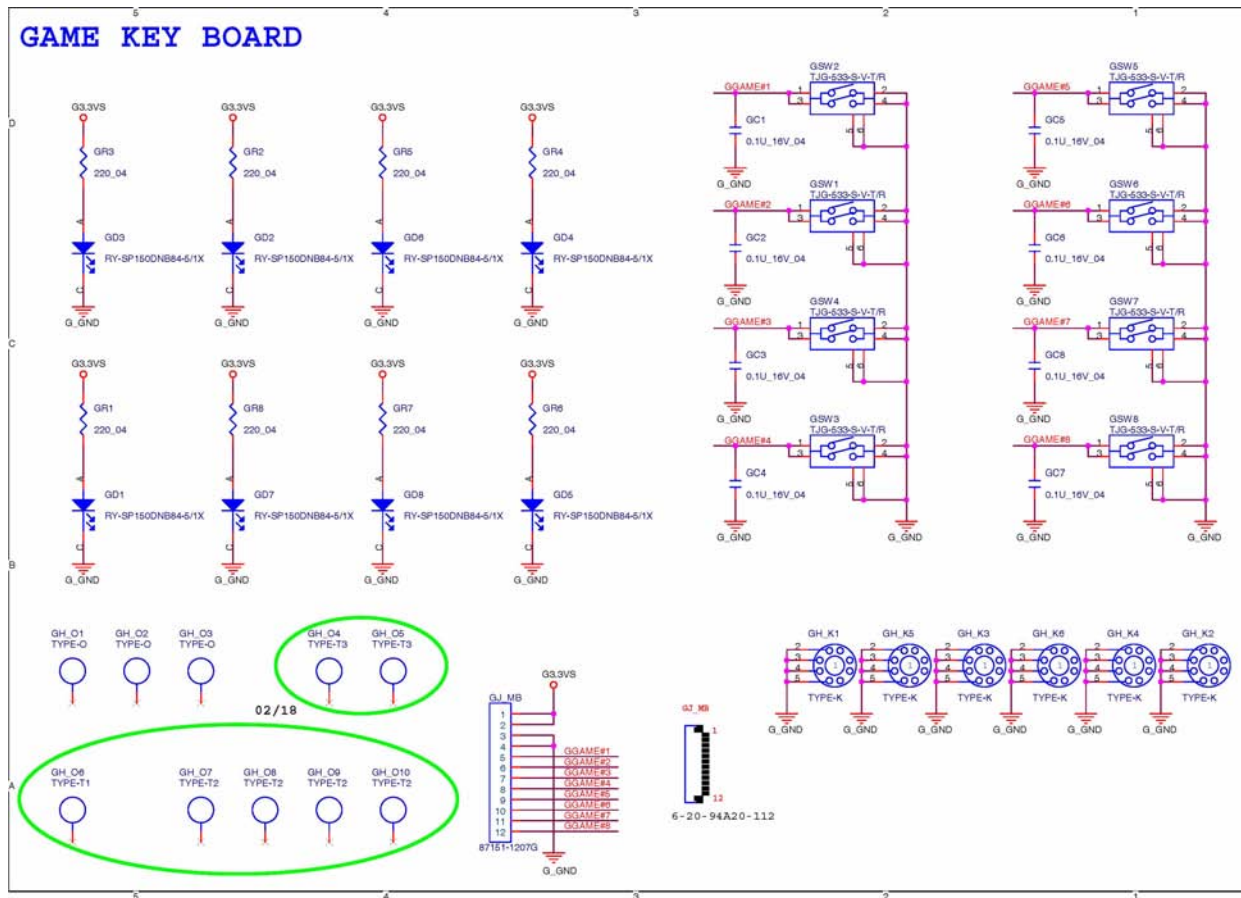

Sheet 44 of 53
Game Key Board

TouchPad LED Board

Sheet 45 of 53
TouchPad LED
Board

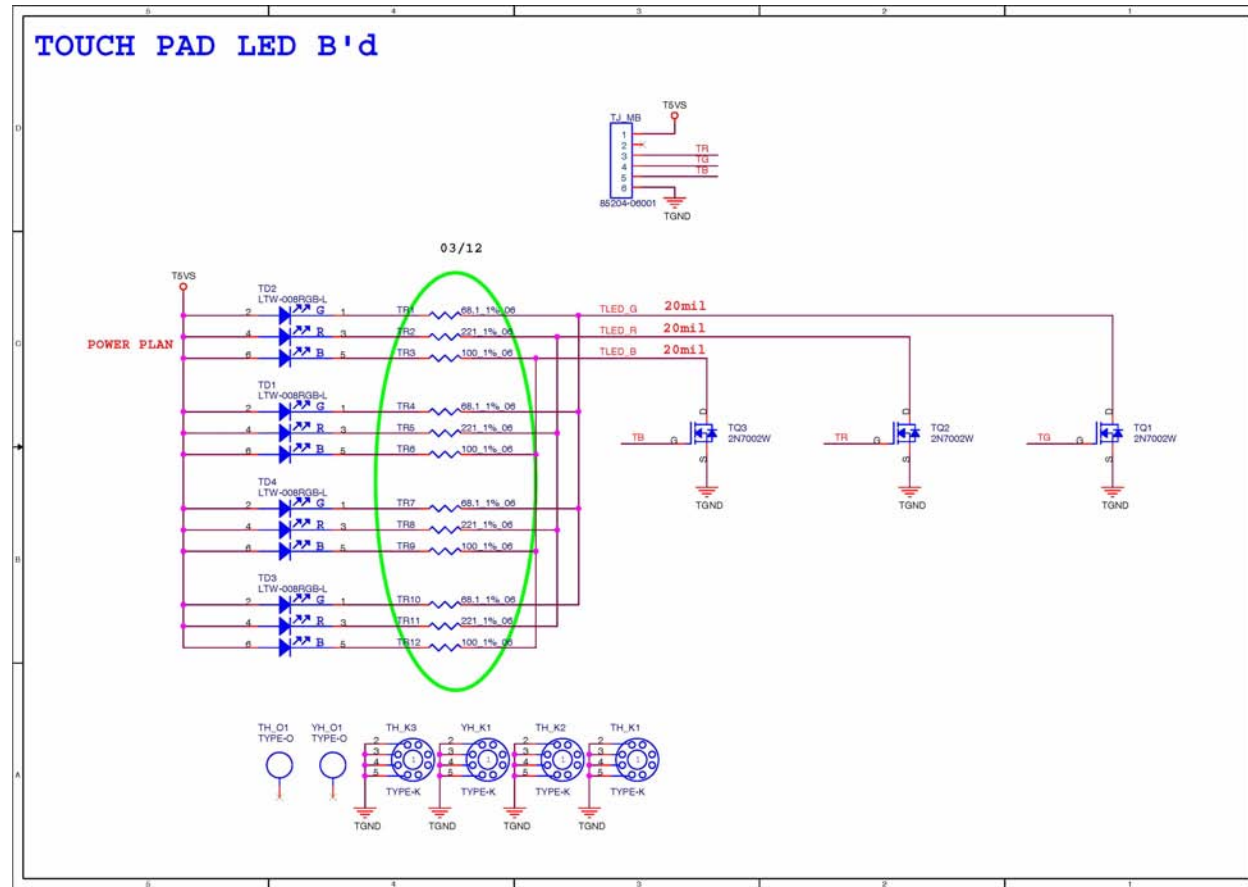

Front R Side LED Board

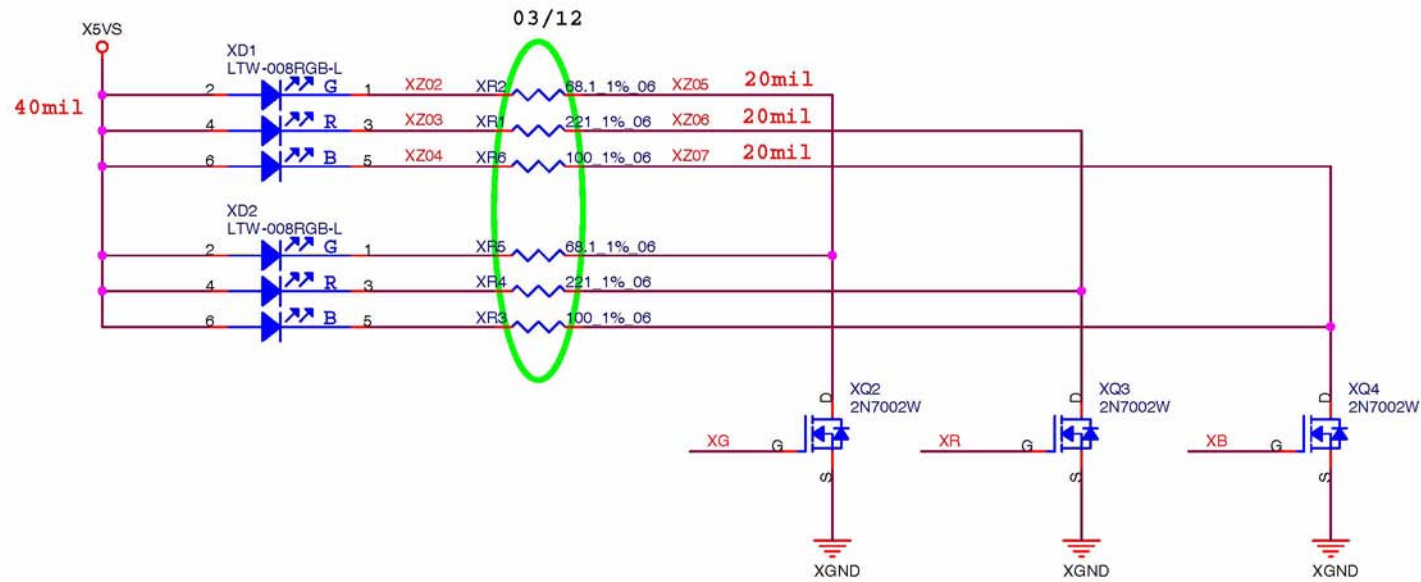

Sheet 46 of 53
Front R Side LED
Board

B. Schematic Diagrams

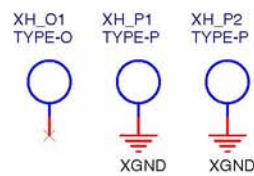

4 3 2 1

Schematic Diagrams

Front L Side LED Board

Sheet 47 of 53
Front L Side LED
Board

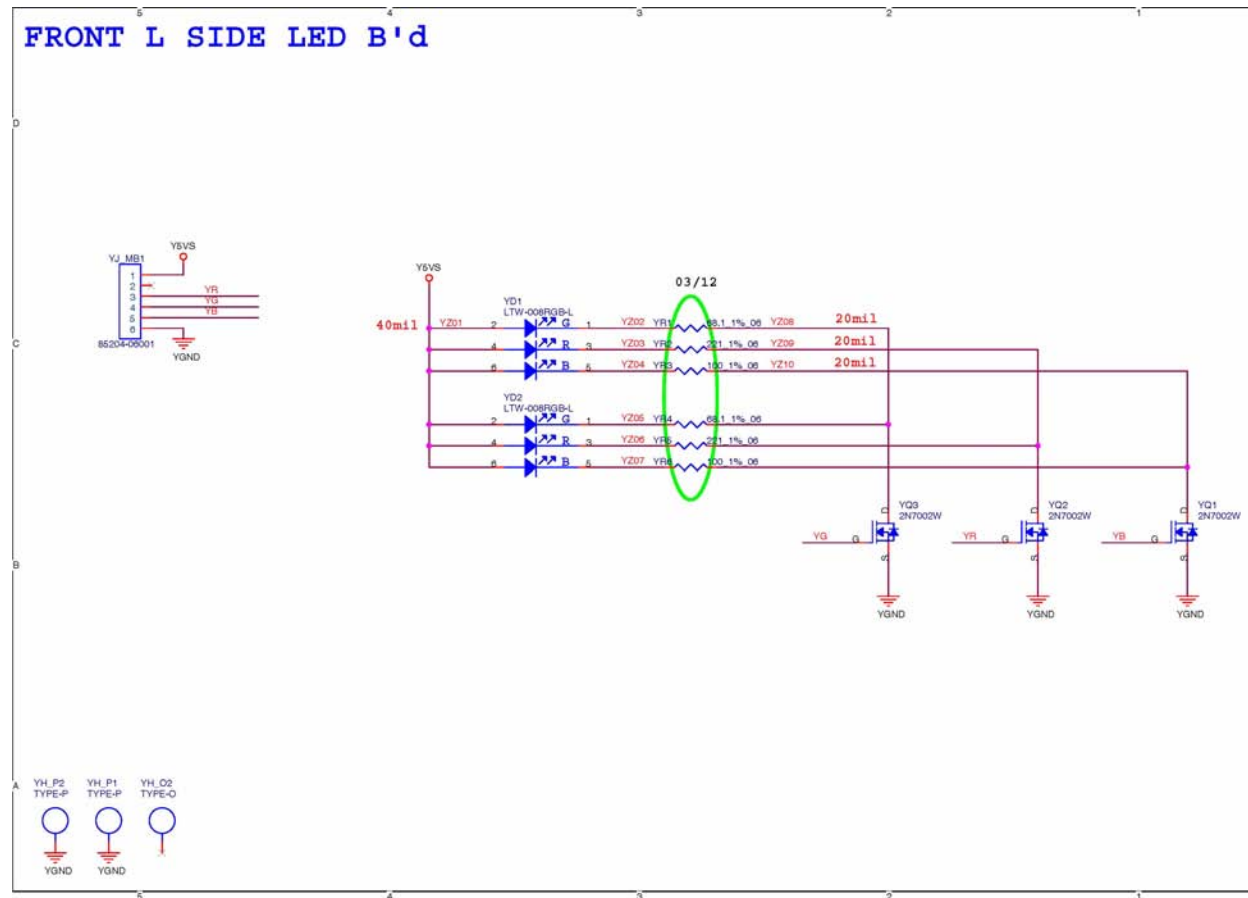

Back L Side LED Board

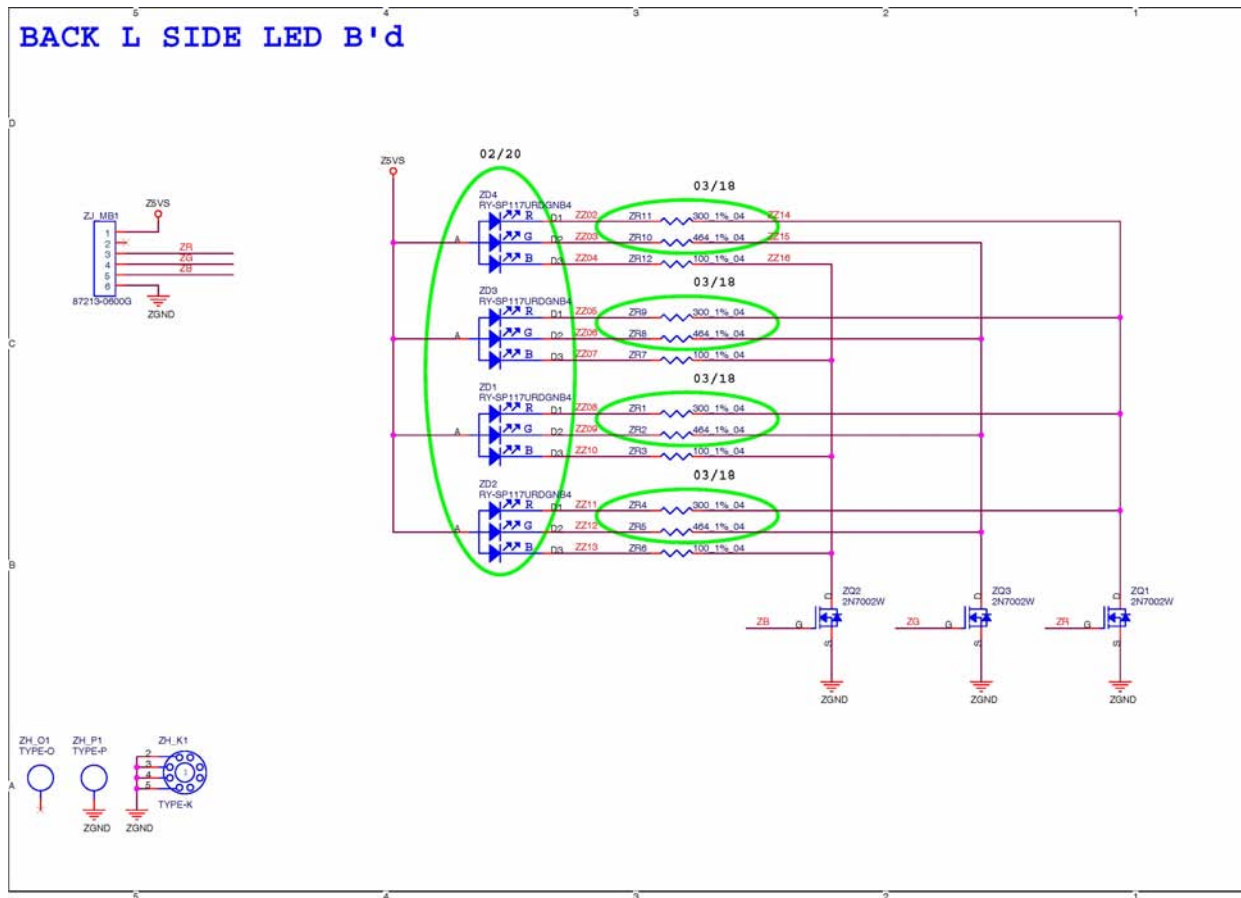

Sheet 48 of 53
Back L Side LED
Board

Schematic Diagrams

Touch Sensor Board A

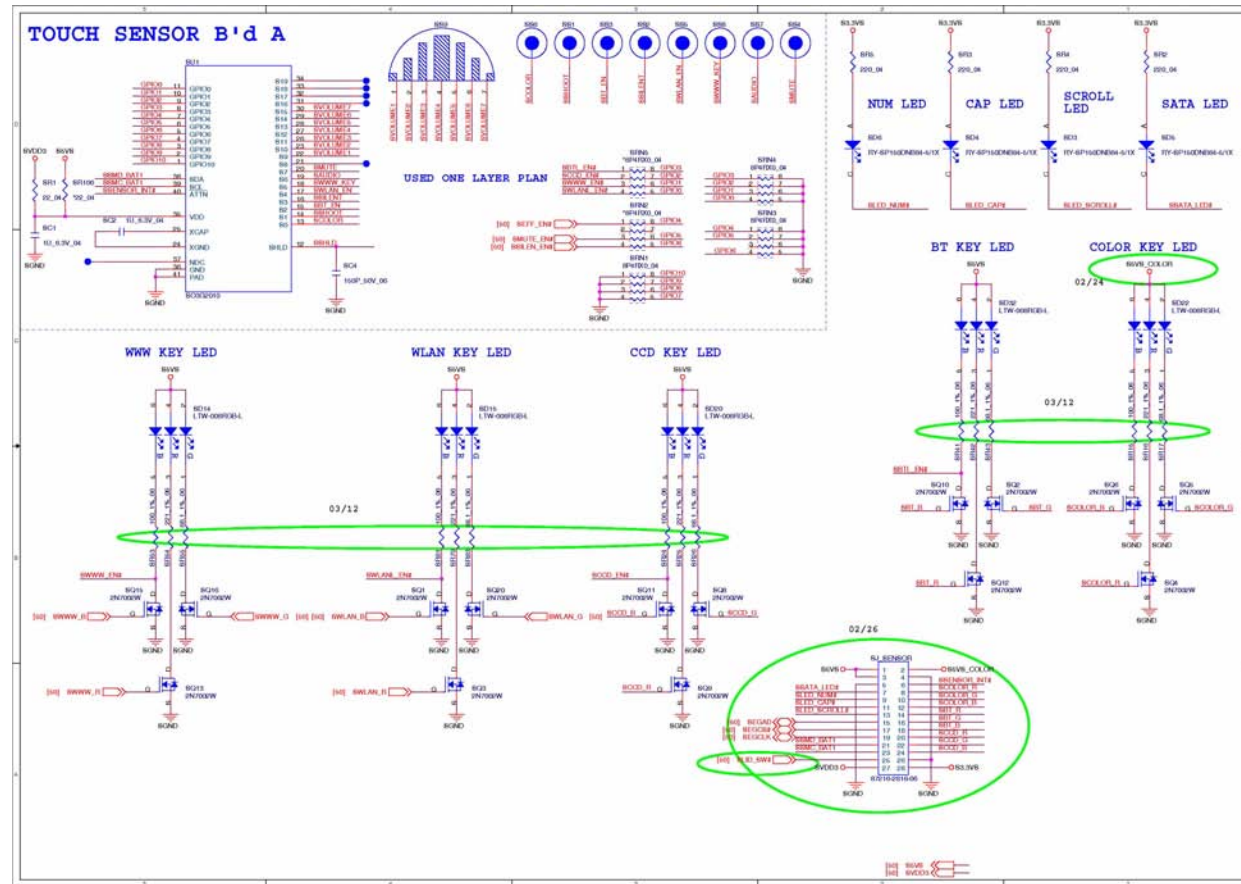

Sheet 49 of 53
Touch Sensor
Board A

B.Schematic Diagrams

Touch Sensor Board B

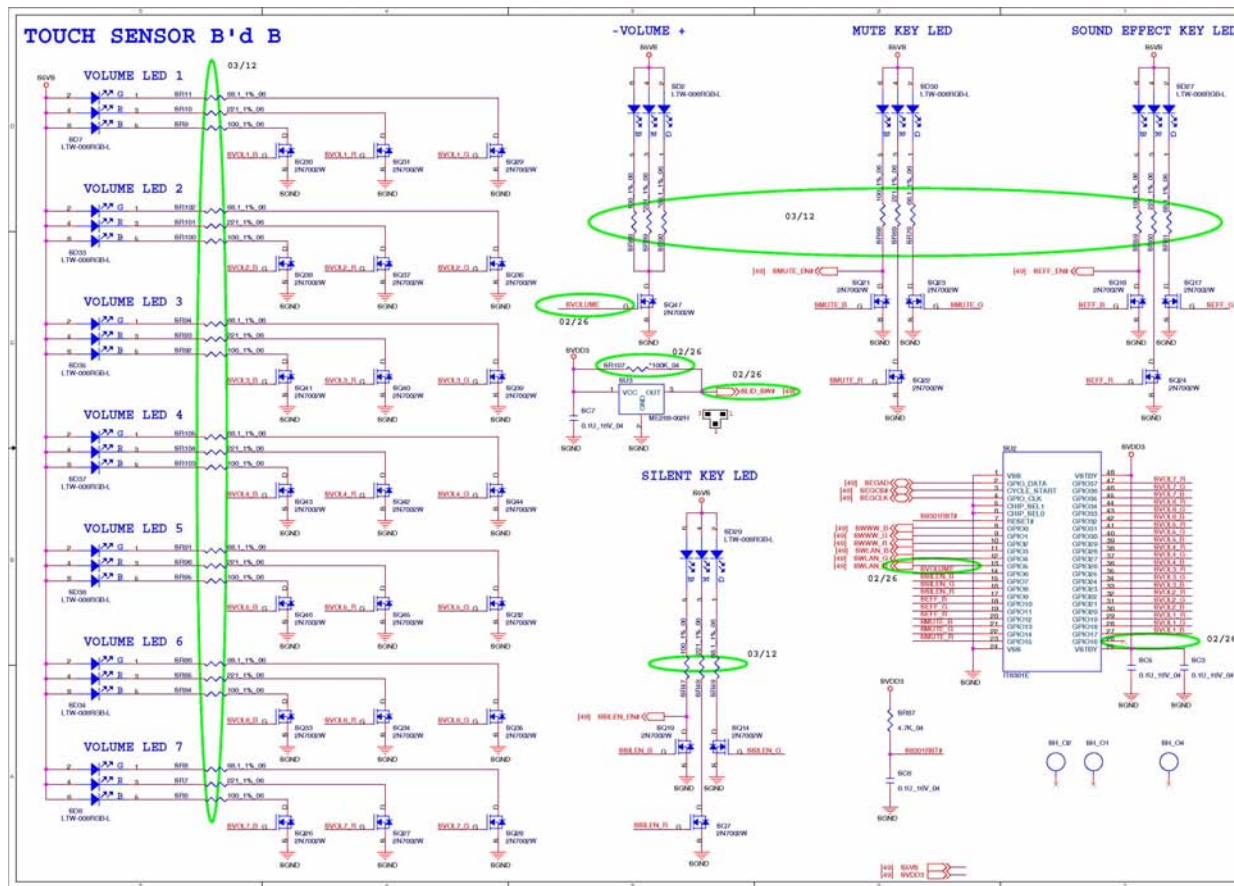

Sheet 50 of 53
Touch Sensor
Board B

B. Schematic Diagrams

CIR Board

CIR BOARD

Sheet 51 of 53
CIR Board

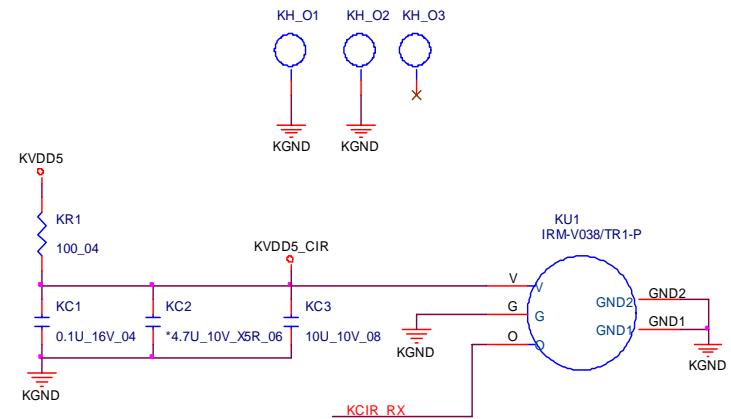
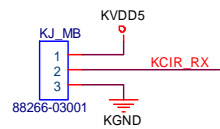

Finger Board

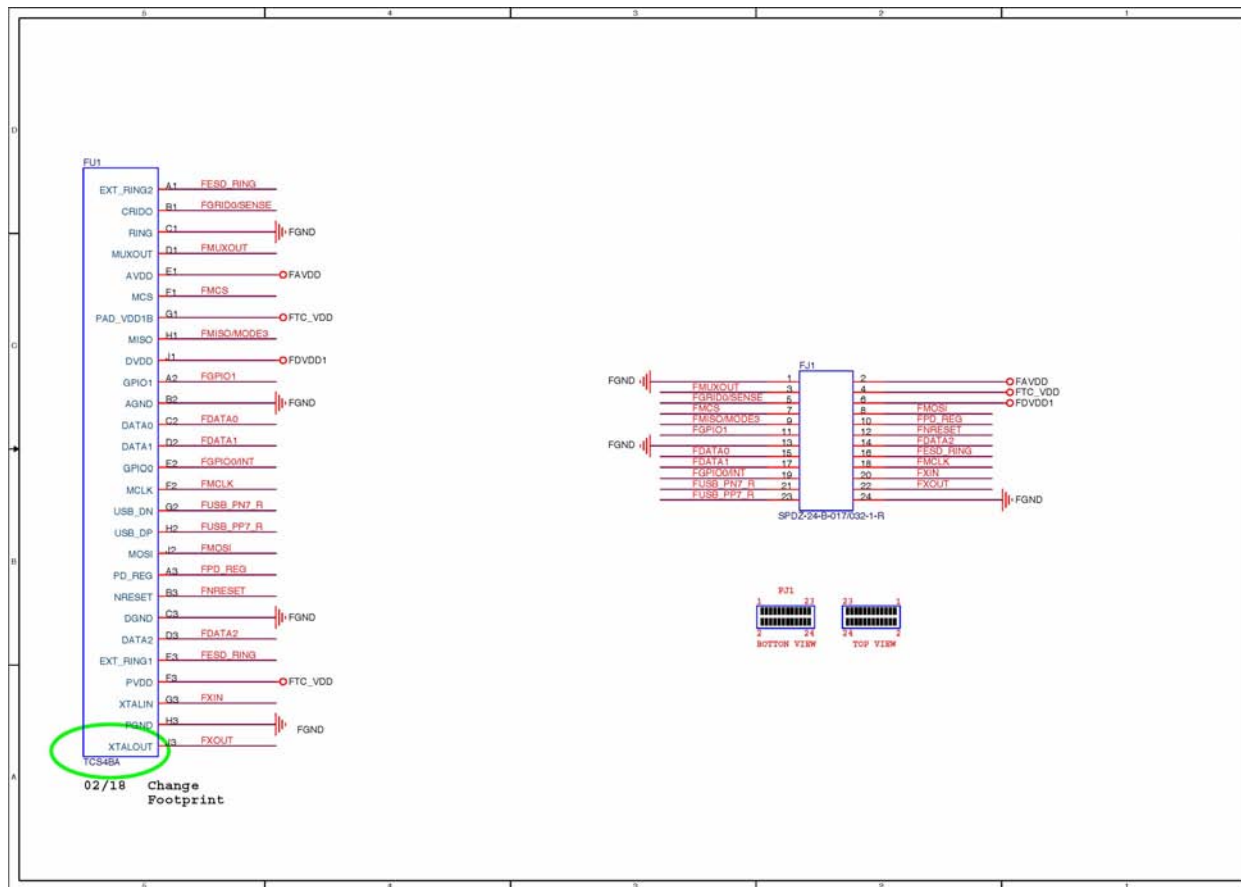

Sheet 52 of 53
Finger Board

PWR on SEQ Diagram

Sheet 53 of 53
PWR on SEQ
Diagram

