

8101E Install  
8111B NA

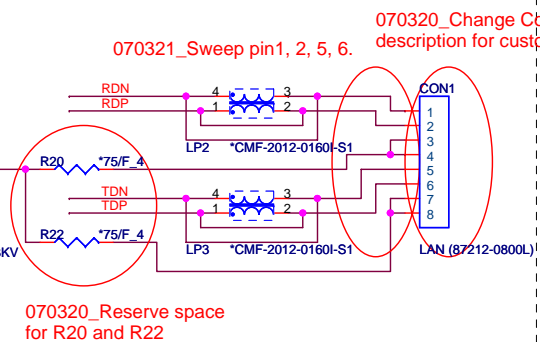

USB CONN

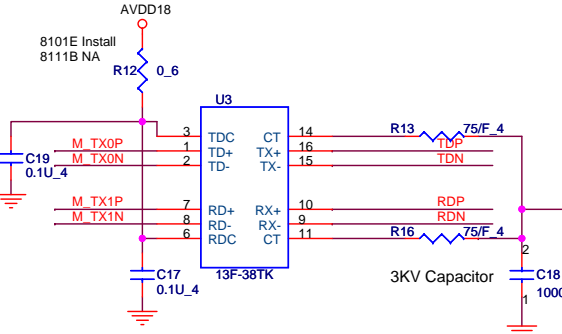
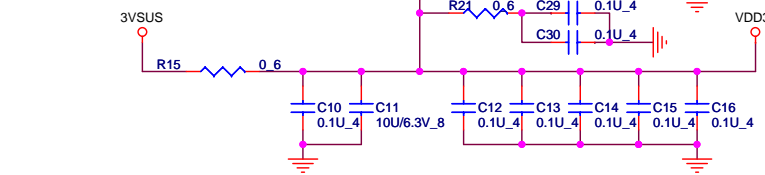
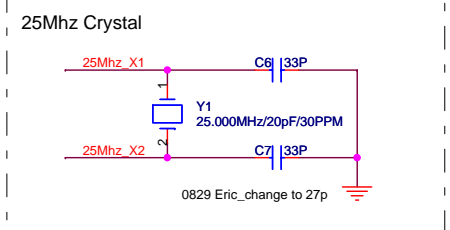
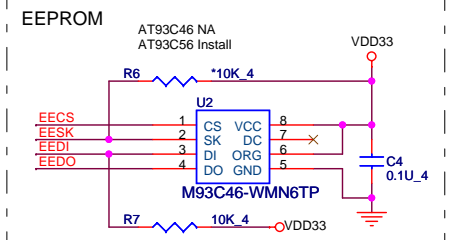
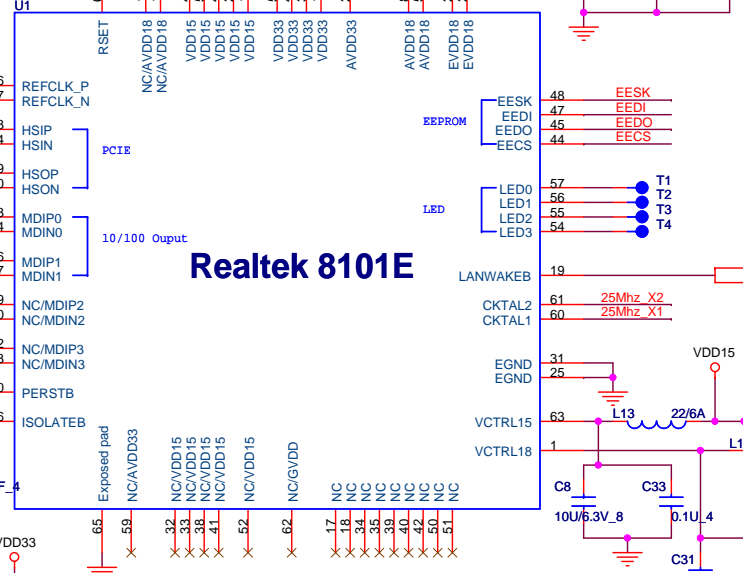
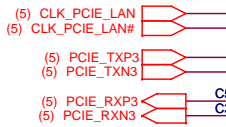
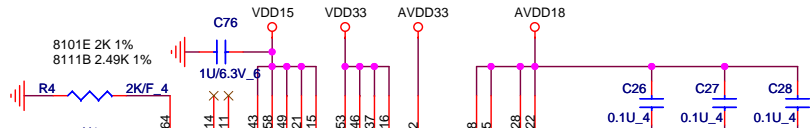
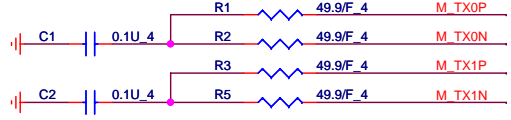
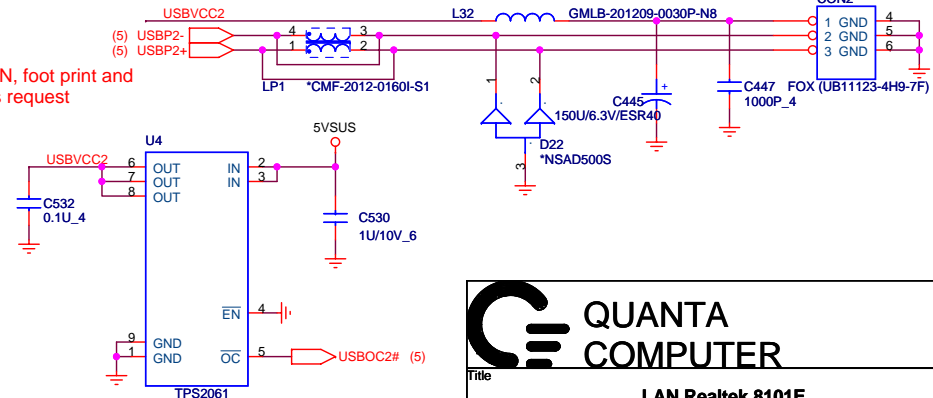

1. Level 1 Environment-related Substances Should NEVER be Used.  
2. Purchase ink, paint, wire rods and molding resins only from the business partners that Sony approves as Green Partners.

**QUANTA COMPUTER**

Title: LAN Realtek 8101E

Size B Document Number: GD1 Charger Board Rev 1A

Date: Wednesday, July 11, 2007 Sheet 1 of 4

DVT:  
PVT:No change

MP:  
a. CAMERA EMI:  
Remove C461, C462 ; ADD L1, C467

Title <Title>		
Size A	Document Number <Doc>	Rev <RevCode>
Date:	Wednesday, July 11, 2007	Sheet 1 of 1

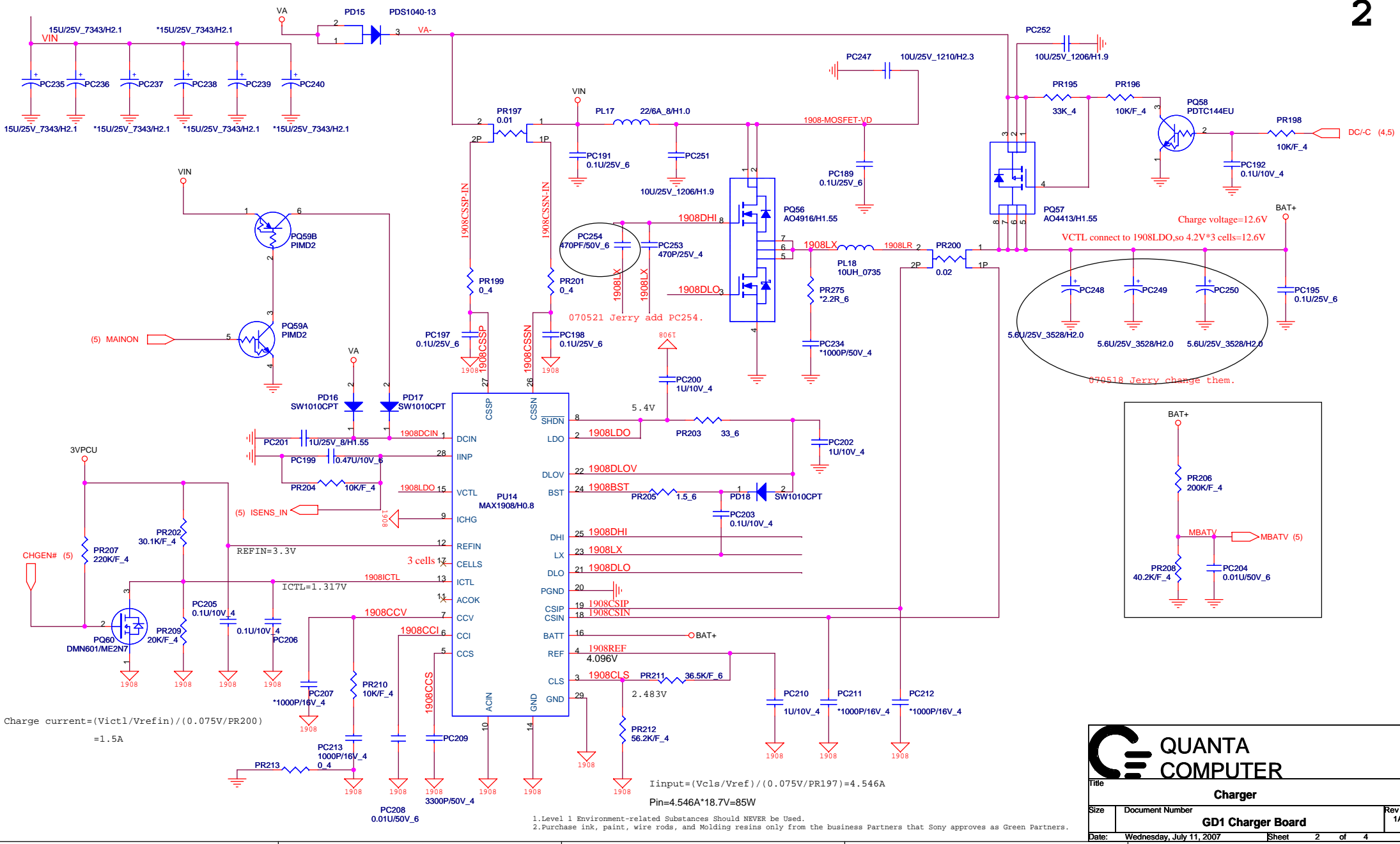

Charge current=(Vicl/Vrefin)/(0.075V/PR200)  
=1.5A

Iinput=(Vcls/Vref)/(0.075V/PR197)=4.546A  
Pin=4.546A\*18.7V=85W

- 1.Level 1 Environment-related Substances Should NEVER be Used.
- 2.Purchase ink, paint, wire rods, and Molding resins only from the business Partners that Sony approves as Green Partners.

**QUANTA COMPUTER**

Title: **Charger**

Size	Document Number	Rev
	<b>GD1 Charger Board</b>	1A

Date: Wednesday, July 11, 2007 Sheet 2 of 4

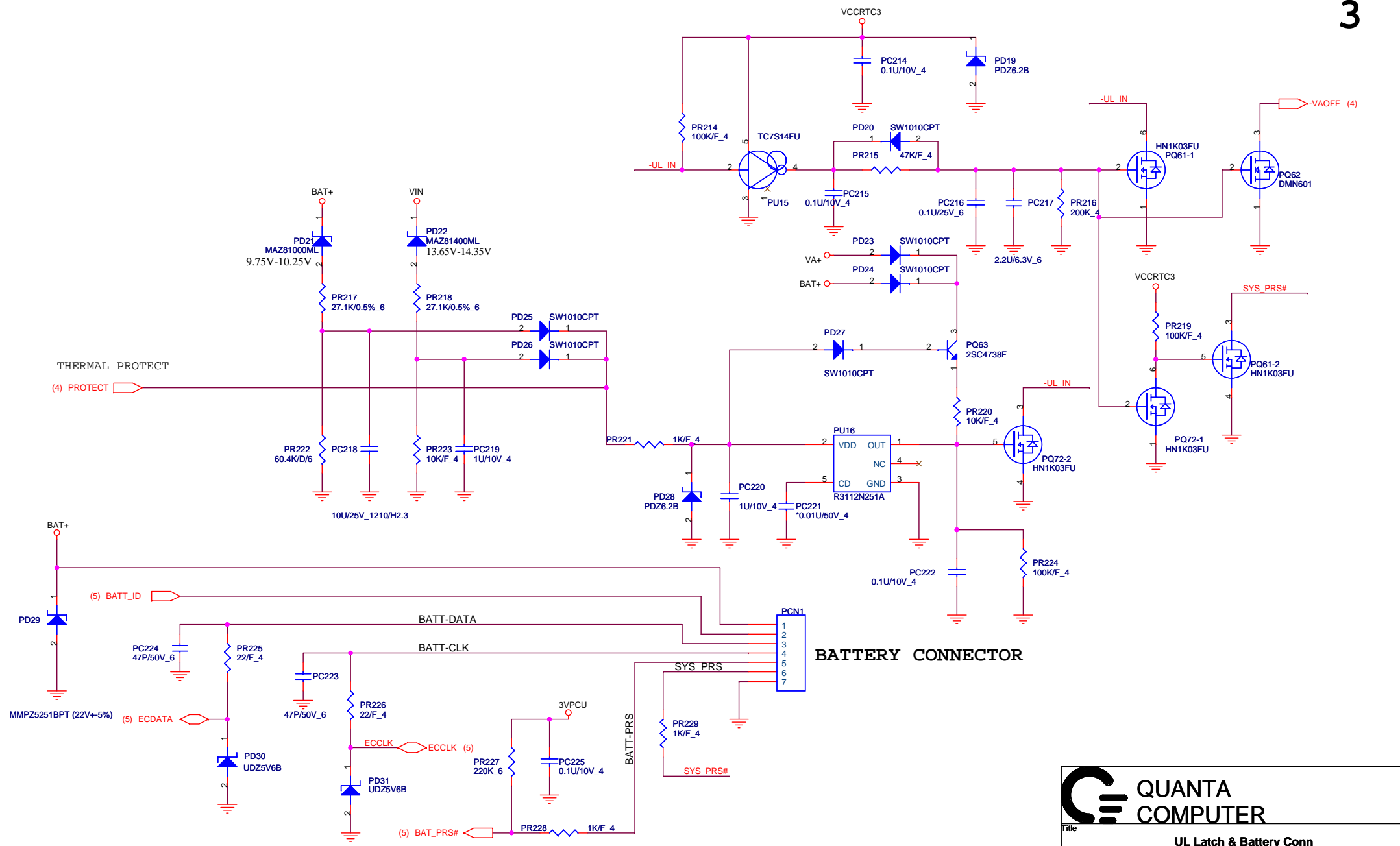

1. Level 1 Environment-related Substances Should NEVER be Used.  
 2. Purchase ink, paint, wire rods, and Molding resins only from the business Partners that Sony approves as Green Partners.

 <b>QUANTA COMPUTER</b>		
Title		
<b>UL Latch &amp; Battery Conn</b>		
Size	Document Number	Rev
B	<b>GD1 Charger Board</b>	1A
Date:	Wednesday, July 11, 2007	Sheet 3 of 4

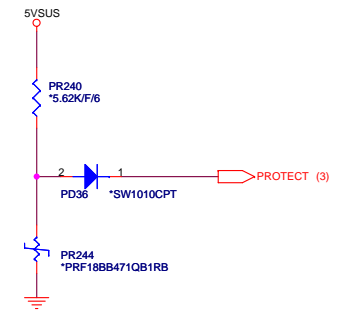
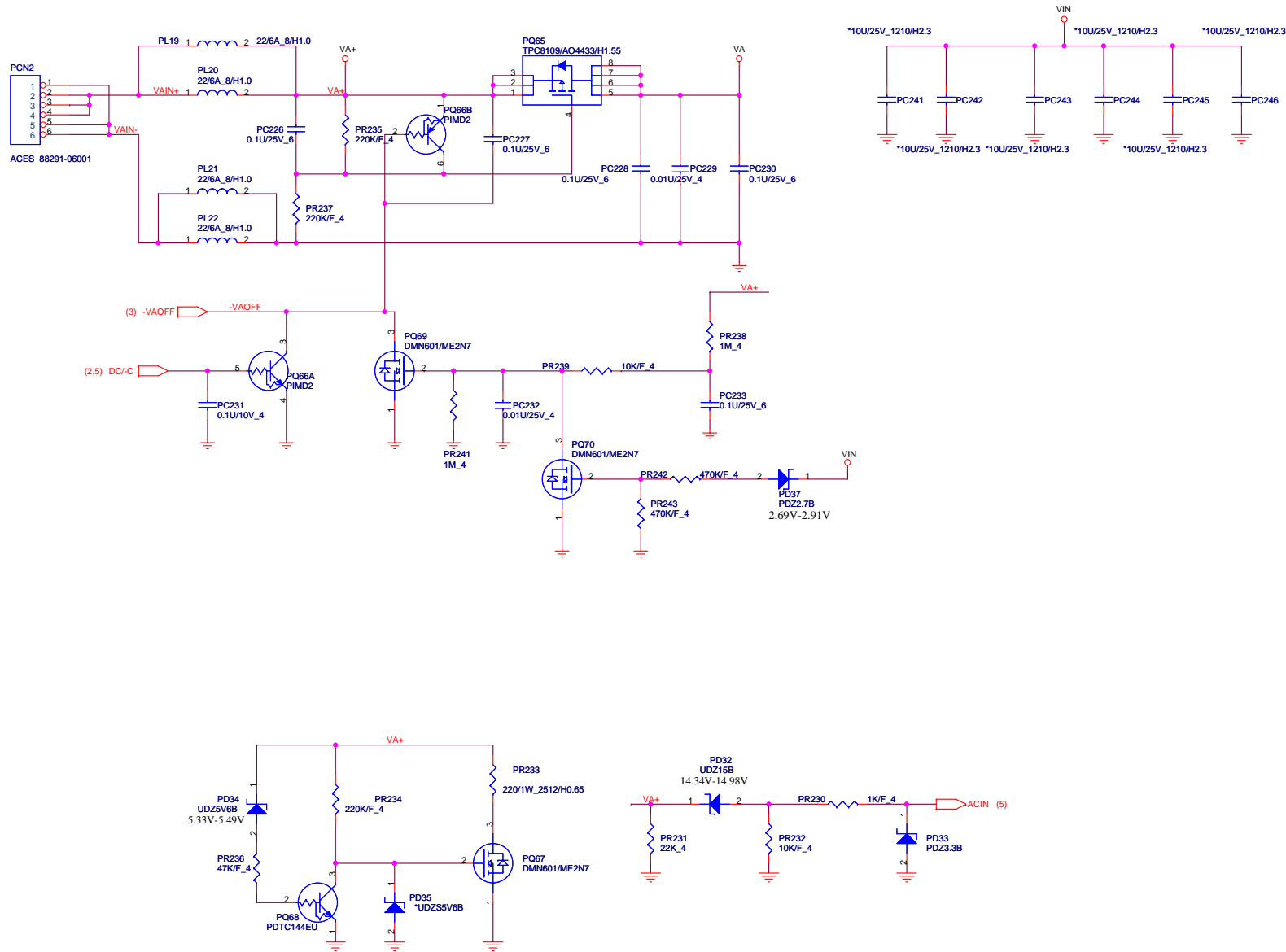

1.Level 1 Environment-related Substances Should NEVER be Used.  
 2.Purchase ink, paint, wire rods, and Molding resins only from the business Partners that Sony approves as Green Partners.

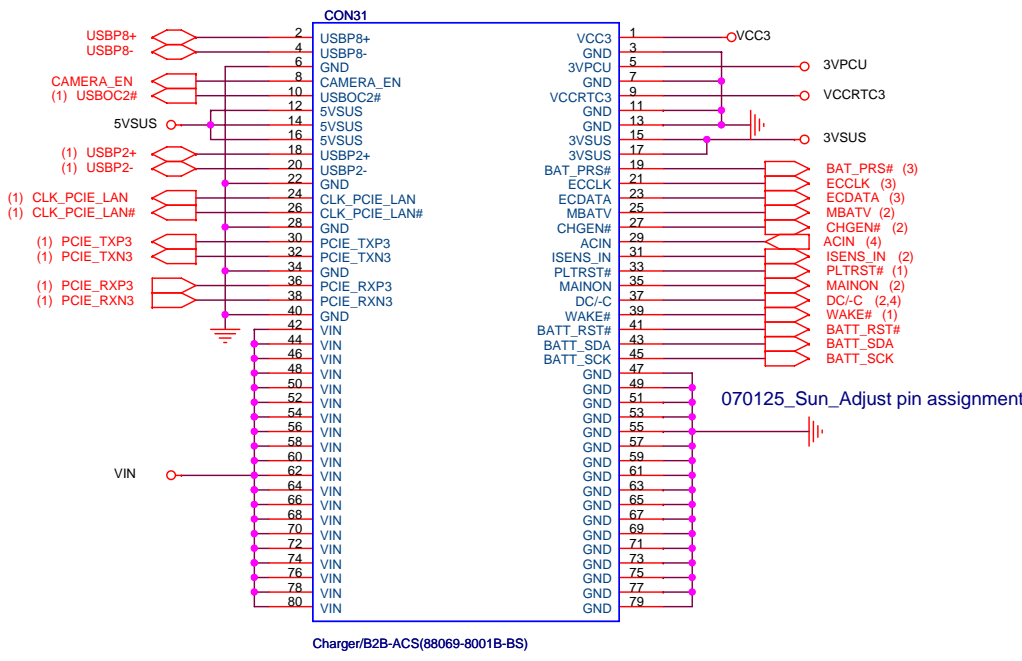

Charger/B2B-ACS(88069-8001B-BS)

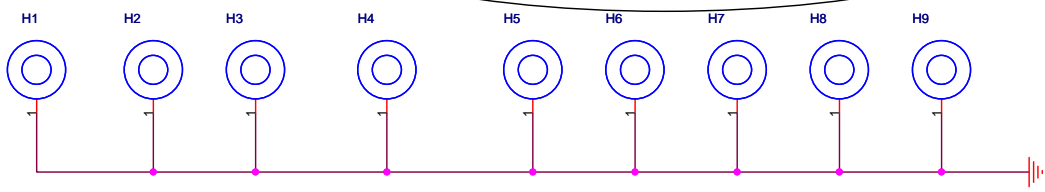
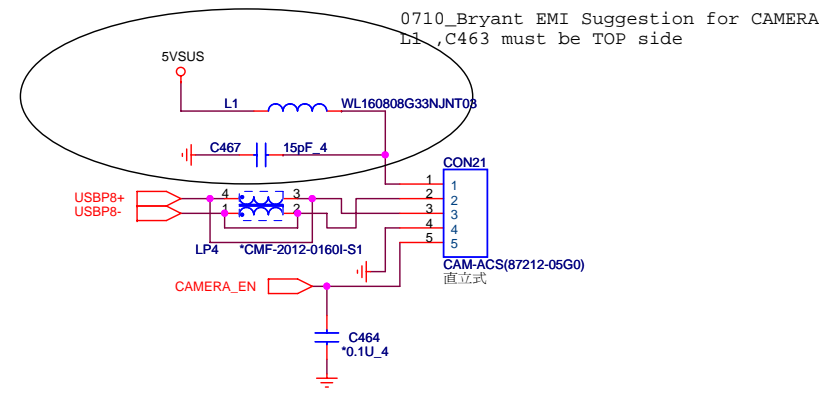
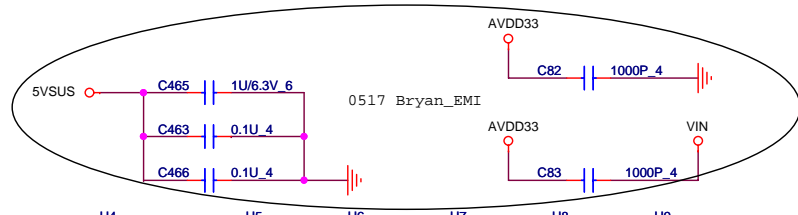
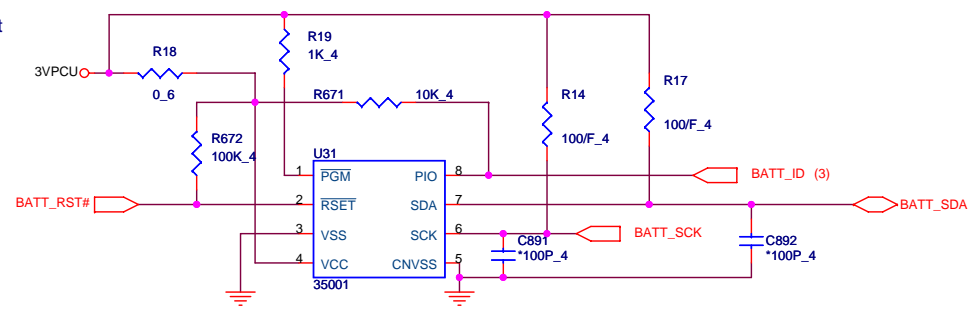

**QUANTA COMPUTER**

Title: **1.8VSUS & VTT\_MEM & Adaptor IN**

Size: B Document Number: **GD1 Charger Board** Rev: 1A

Date: Wednesday, July 11, 2007 Sheet: 5 of 4

1.Level 1 Environment-related Substances Should NEVER be Used.  
 2.Purchase ink, paint, wire rods and molding resins only from the business partners that Sony approves as Green Partners.