

VM8G Block Diagram Intel Discrete GFX

VER : F3B

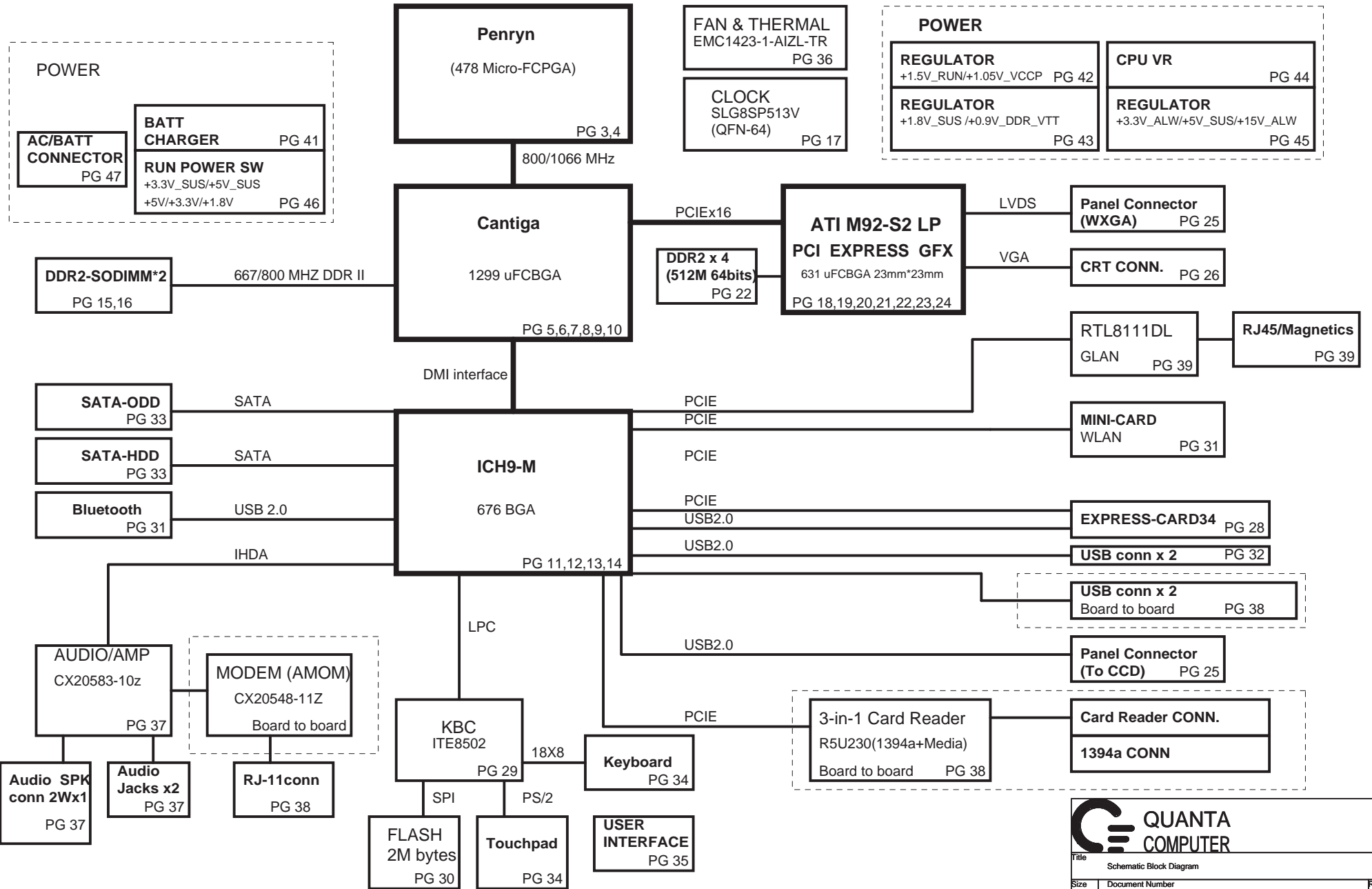

File: Schematic Block Diagram		
Size: VM8G	Document Number: VM8G	Rev: 1B
Date: Saturday, June 06, 2009	Sheet: 1	of 53

Table of Contents

PAGE	DESCRIPTION
1	Schematic Block Diagram
2	Front Page
3-4	Penryn
5-10	Cantiga
11-14	ICH9M
15-16	DDRII SO-DIMM(200P)
17	Clock Generator
18-24	M92-S2
25	LCD Conn.
26	CRT Conn
27	BLANK PAGE
28	Express Card
29	SIO (ITE8512)
30	FLASH/RTC
31	Mini Card / BT
32	USB
33	SATA Conn
34	TP / KEYBOARD
35	SWITCH /LED
36	FAN & Thermal
37	Audio CODEC(CX20583-10z)/Phone Jack
38	Module Board
39	LAN / TRANSFORM
40	BLANK PAGE
41	Charger (MAX8731A)
42	1.05VCCP / 1.5VRUJN
43	DDR2_1.8VSUS, 0.9V
44	CPU MAX17410 (2phase)
45	MAX17020 (+5.5V,+3.3V)
46	RUN Power Switch
47	DCIN,Batt
48	PAD& SCREW
49	VGA GFX CORE
50	EMI CAP
51	SMBUS BLOCK
52	Power Block Dianram

Power States

POWER PLANE	VOLTAGE	PAGE	DESCRIPTION	CONTROL SIGNAL	ACTIVE IN
+PWR_SRC	10V~+19V	4,25,30,39,41,42,43,44,45,49,50	MAIN POWER		S0-S5
+RTC_CELL	+3.0V~+3.3V	11,14,29,30	RTC		S0-S5
+3.3V_ALW	+3.3V	3,13,29,30,35,39,40,41,43,45,46,47	8051 POWER	ALWON	S0-S5
+5V_ALW2	+5V	42,43,45,46,47,49	LCD/CHARGE POWER	ALWON	S0-S5
+15V_ALW	+15V	25,45,46	LARGE POWER	+5V_ALW	S0-S5
+3.3V_LAN	+3.3V	39	LAN POWER	AUX_ON	
+5V_SUS	+5V	14,32,35,44,45,46,49,50	SLP_S5# CTRLD POWER	SUS_ON	
+3.3V_SUS	+3.3V	3,11,12,13,14,19,25,28,35,42,44,46,49	SLP_S5# CTRLD POWER	3.3V_SUS_ON	
+1.8V_SUS	+1.8V	6,8,9,15,42,43,46,49	SODIMM POWER	DDR_ON	
+0.9V_DDR_VTT	+0.9V	16,43,46	SODIMM POWER	0.9V_DDR_VTT_ON	
+5V_RUN	+5V	14,20,25,26,33,34,35,36,37,46,50	SLP_S3# CTRLD POWER	RUN_ON	
+3.3V_RUN	+3.3V	3,6,8,9,11,12,13,14,15,17,19,25,26,27,28,29,31,33,35,36,37,39,46,50	SLP_S3# CTRLD POWER	3.3V_RUN_ON	
+1.5V_RUN	+1.5V	4,9,14,28,31,42,46,50	CALISTOGA/ICH8 POWER	1.5V_RUN_ON	
+1.05V_VCCP	+1.05V	3,4,5,6,8,9,11,14,42,50	CPU/CALISTOGA/ICH8 POWER	1.05V_RUN_ON	
+VCC_CORE	+0.7V~+1.77V	4,44	CPU CORE POWER	IMVP_VR_ON	
+LCDVCC	+3.3V	25	LCD Power	LCDVCC_TST_EN & ENVDD	
+5V_MOD	+5V	33	Module Power	MODC_EN#	
+5V_HDD	+5V	33	HDD Power	HDDC_EN#	
+PBATT	+10V~+17V		MAIN BATTERY	CHG_PBATT	
+SBATT	+10V~+17V		SECOND BATTERY	CHG_SBATT	
+1.1V_GFX_PCIE	+1.1V	20	GFX PCIE POWER	GFX_RUN_ON	
+VCC_GFX_CORE	+0.9~+1.1	20,23,49	GFX CORE POWER	GFX_RUN_ON	

GND PLANE	PAGE	DESCRIPTION
 GND	ALL	

		QUANTA COMPUTER
Title: Index & Power Status		
Size	Document Number VM8G	Rev 1B
Date: Tuesday, June 02, 2009	Sheet 2	of 53

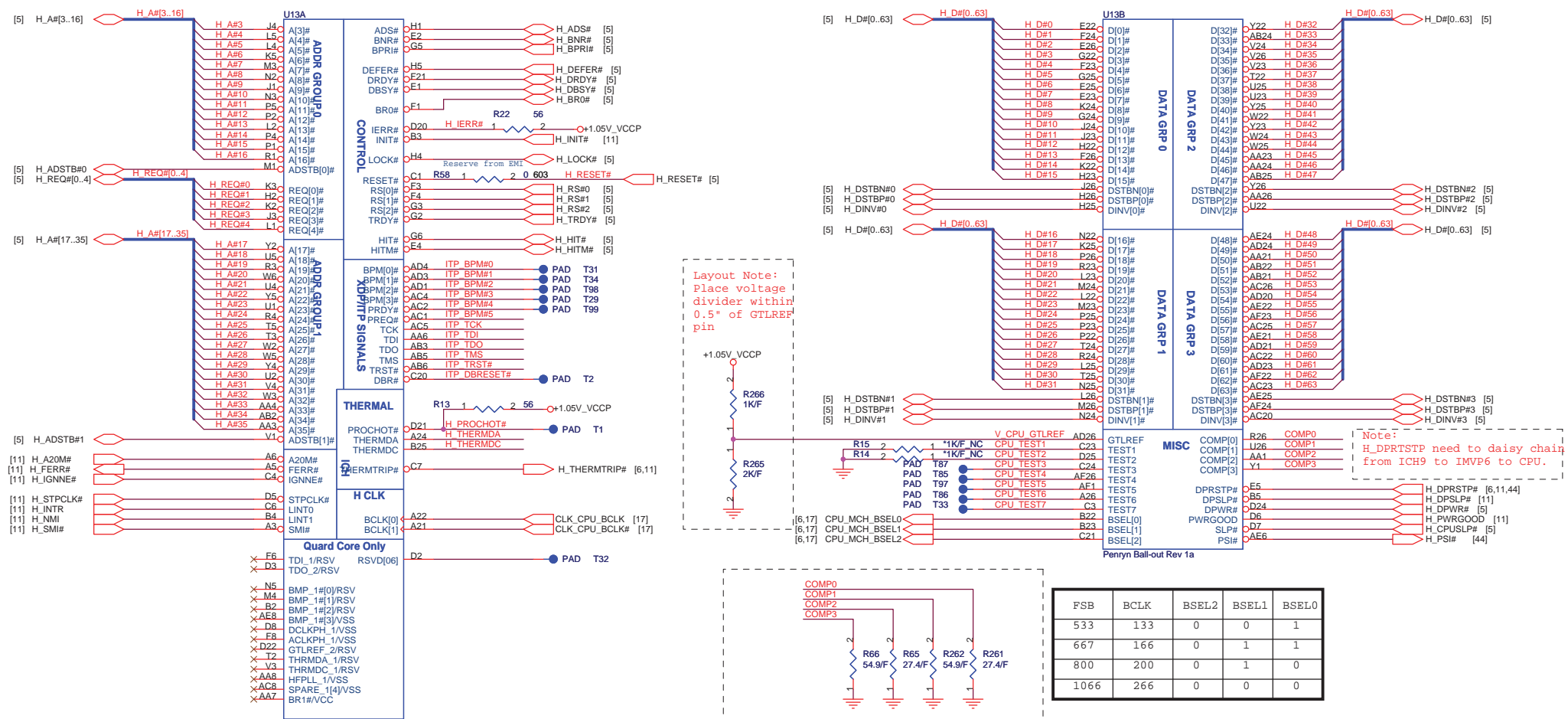

FSB	BCLK	BSEL2	BSEL1	BSEL0
533	133	0	0	1
667	166	0	1	1
800	200	0	1	0
1066	266	0	0	0

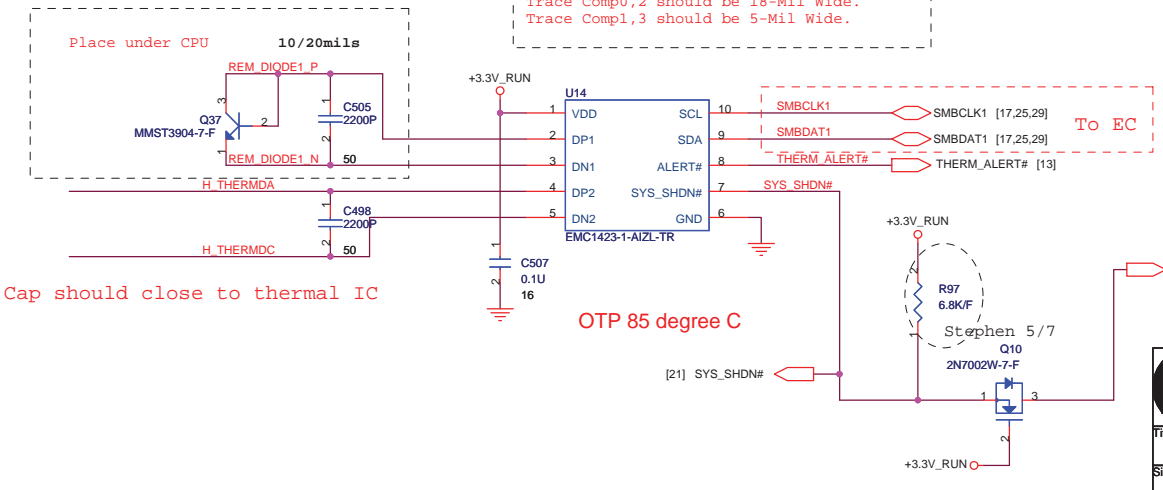
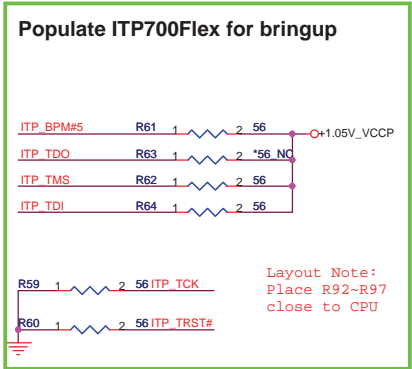

QUANTA COMPUTER

File: Penryn Processor (HOST BUS)

Size: Document Number VM8G Rev 1B

Date: Tuesday, June 02, 2009 Sheet 3 of 53

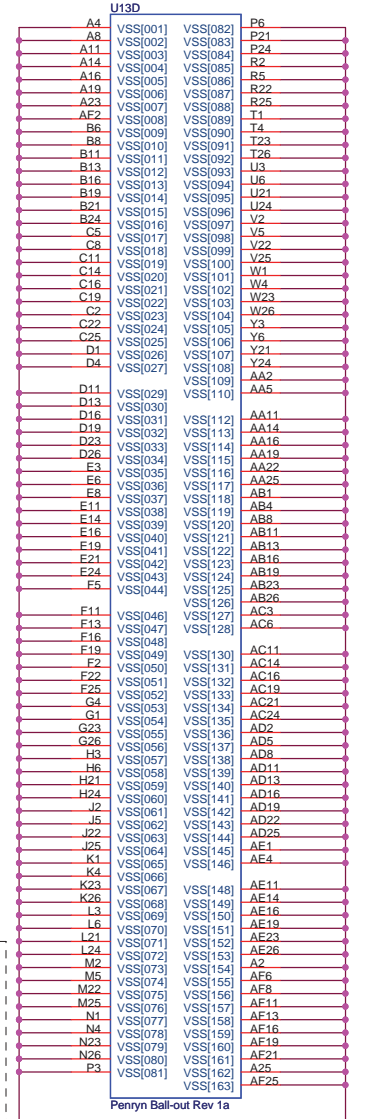
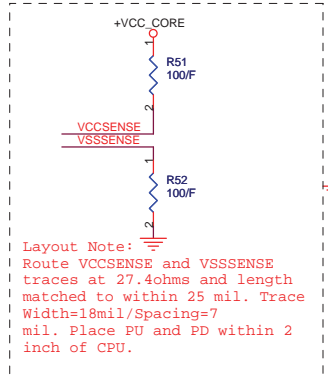
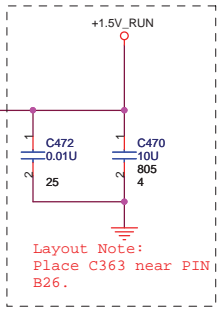
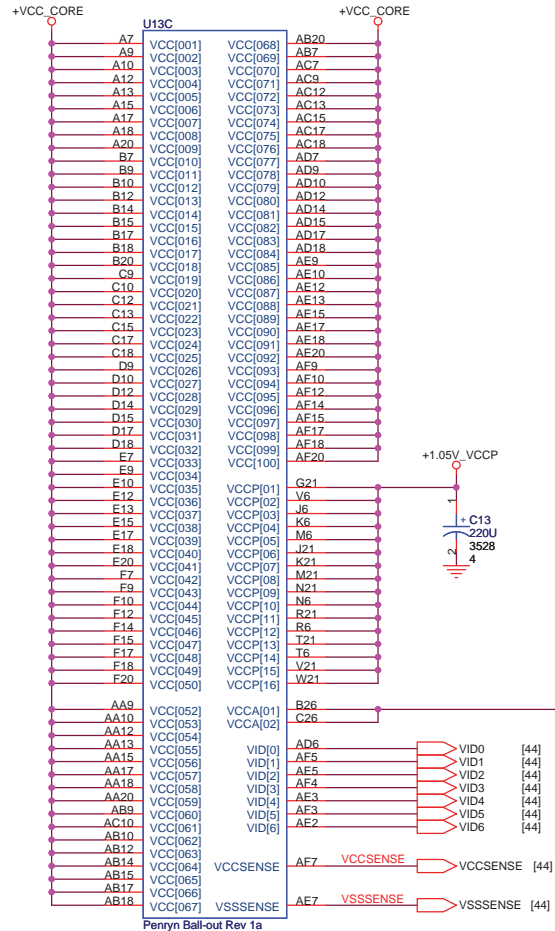
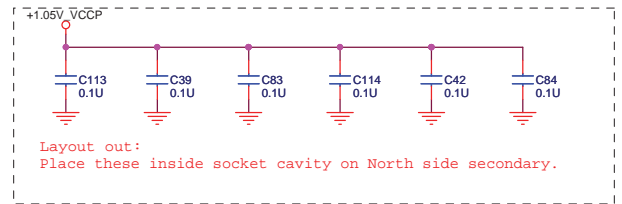
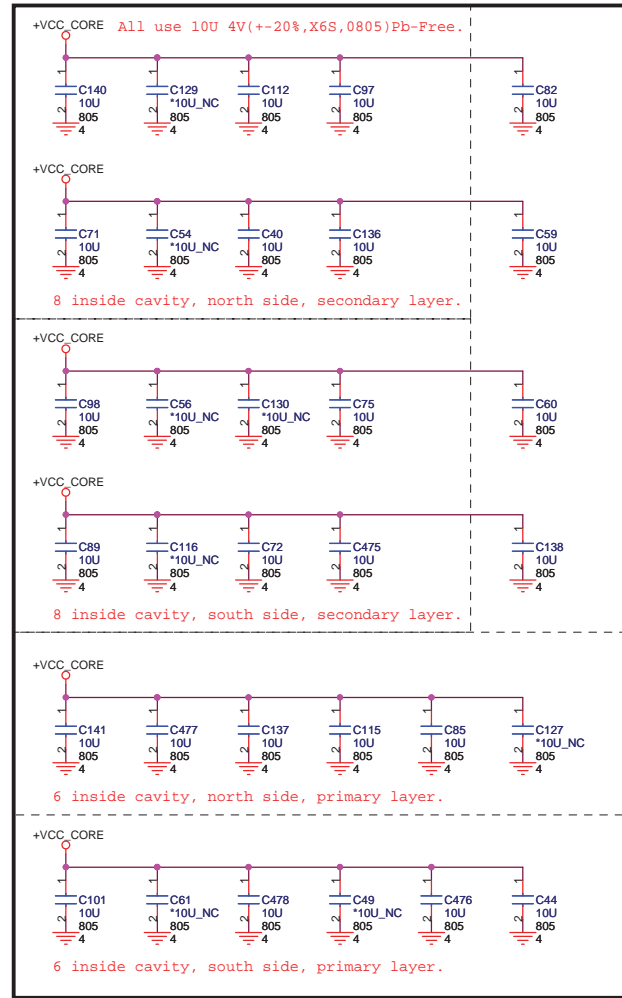

QUANTA COMPUTER

Title: Penryn Processor (POWER)

Size	Document Number VM8G	Rev 1B
------	----------------------	--------

Date: Tuesday, June 02, 2009 Sheet 4 of 53

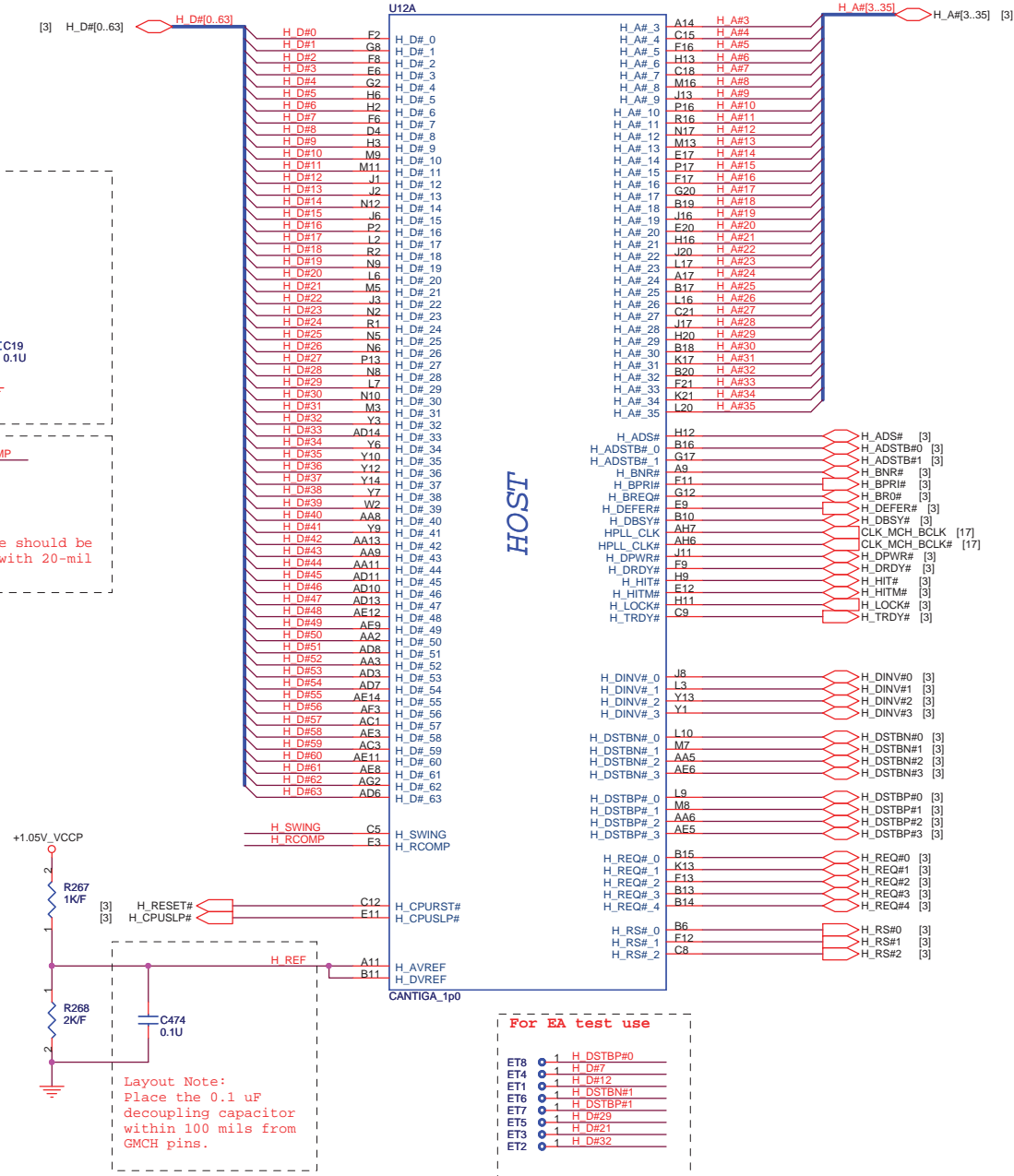
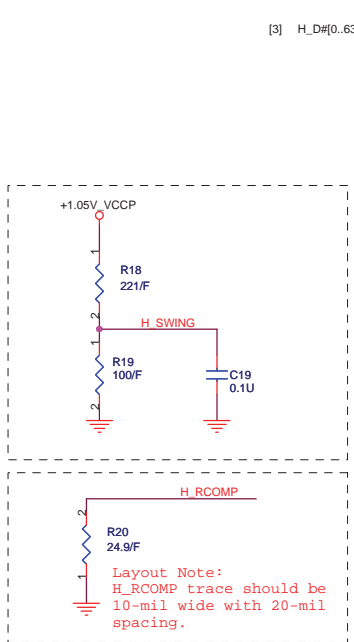

QUANTA COMPUTER

File: Caniga (HOST)

Size	Document Number VM&G	Rev 1B
Date: Saturday, June 06, 2009	Sheet 5 of 53	

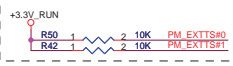
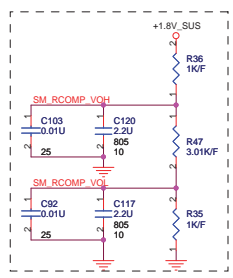

Layout Note:
Location of all MCH_CFG strap resistors needs to be close to minimize stub.

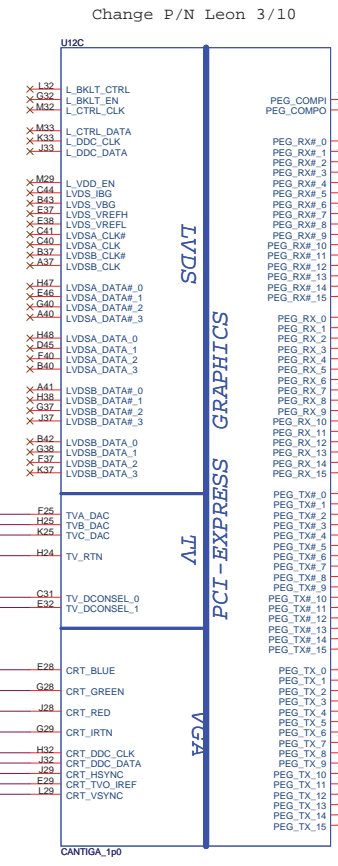
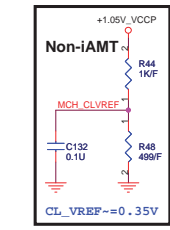
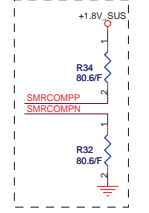
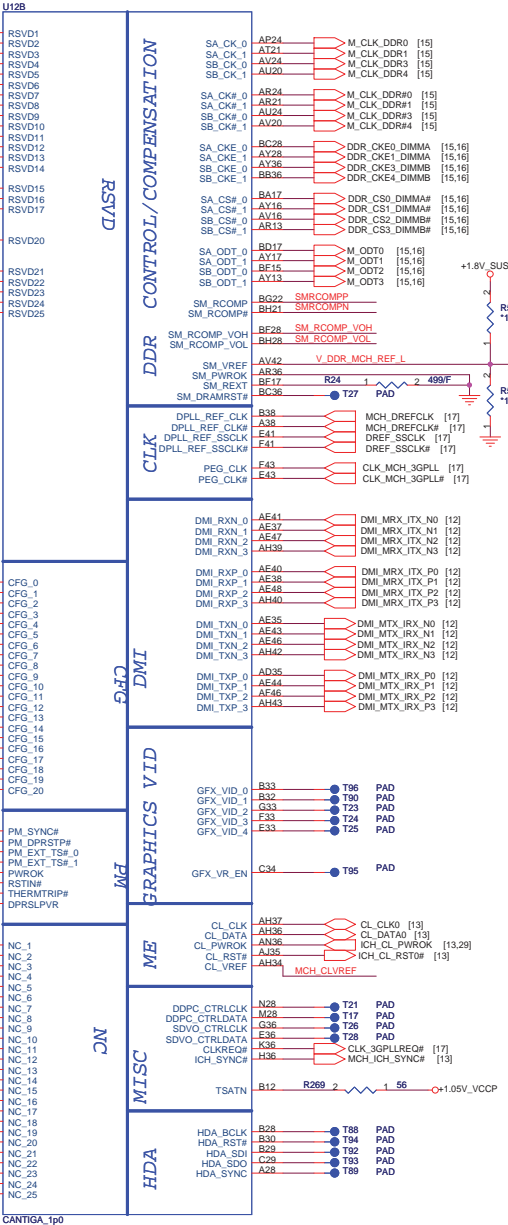
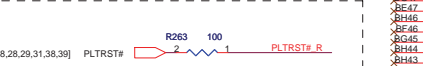
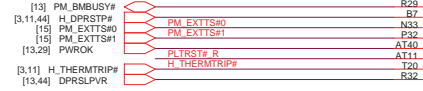
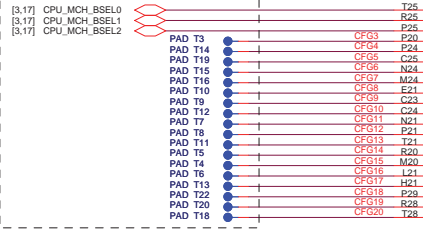

CFG5	DMI X2 Select	Low=DMIx2 High=DMIx4(Default)
CFG9	PCI Express Graphic Lane	Low=Reverse Lane High=Normal operation
CFG16	FSB Dynamic ODT	Low=Dynamic ODT Disable High=Dynamic ODT Enable(default).
CFG19	DMI Lane Reversal	Low=Normal(default). High=Lane Reversed
CFG20	SDVO/PCIe Concurrent Operation	Low=Only SDVO or PCIe1 is operational (default). High=SDVO and PCIe1 are operating simultaneously via PEG port
SDVO_CTRL_DATA	SDVO Present	Low=No SDVO Device Present (default). High=SDVO Device Present

Layout Note:
place R189 close to MCH, 500mil

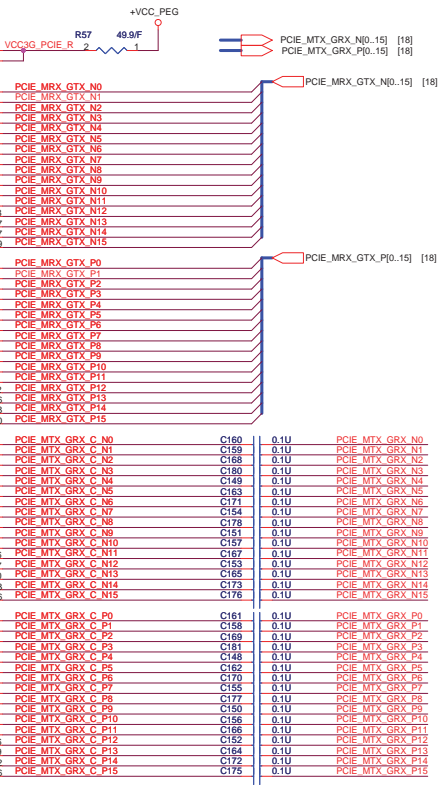

Title Cantiga (VGA,DMI)		
Size VM8G	Document Number VM8G	Rev 1B
Date: Saturday, June 06, 2009	Sheet 6	of 53

[15] DDR_A_D[0..63]

DDR A D0	AJ38	SA_DO_0
DDR A D1	AJ41	SA_DO_1
DDR A D2	AN38	SA_DO_2
DDR A D3	AM38	SA_DO_3
DDR A D4	AJ36	SA_DO_4
DDR A D5	AJ40	SA_DO_5
DDR A D6	AM44	SA_DO_6
DDR A D7	AM42	SA_DO_7
DDR A D8	AN43	SA_DO_8
DDR A D9	AN44	SA_DO_9
DDR A D10	AJ40	SA_DO_10
DDR A D11	AT38	SA_DO_11
DDR A D12	AN41	SA_DO_12
DDR A D13	AN39	SA_DO_13
DDR A D14	AJ44	SA_DO_14
DDR A D15	AJ42	SA_DO_15
DDR A D16	AV35	SA_DO_16
DDR A D17	AY44	SA_DO_17
DDR A D18	BA40	SA_DO_18
DDR A D19	BD43	SA_DO_19
DDR A D20	AV41	SA_DO_20
DDR A D21	AY43	SA_DO_21
DDR A D22	BB41	SA_DO_22
DDR A D23	BC40	SA_DO_23
DDR A D24	AY37	SA_DO_24
DDR A D25	BD38	SA_DO_25
DDR A D26	AV37	SA_DO_26
DDR A D27	AT36	SA_DO_27
DDR A D28	AY38	SA_DO_28
DDR A D29	BB38	SA_DO_29
DDR A D30	AV36	SA_DO_30
DDR A D31	AW36	SA_DO_31
DDR A D32	BD13	SA_DO_32
DDR A D33	AJ11	SA_DO_33
DDR A D34	BC11	SA_DO_34
DDR A D35	BA12	SA_DO_35
DDR A D36	AJ13	SA_DO_36
DDR A D37	AV13	SA_DO_37
DDR A D38	BD12	SA_DO_38
DDR A D39	BC12	SA_DO_39
DDR A D40	BB9	SA_DO_40
DDR A D41	BA9	SA_DO_41
DDR A D42	AJ10	SA_DO_42
DDR A D43	AV9	SA_DO_43
DDR A D44	BA11	SA_DO_44
DDR A D45	BD9	SA_DO_45
DDR A D46	AY8	SA_DO_46
DDR A D47	BA6	SA_DO_47
DDR A D48	AV5	SA_DO_48
DDR A D49	AV7	SA_DO_49
DDR A D50	AT9	SA_DO_50
DDR A D51	AN8	SA_DO_51
DDR A D52	AJ5	SA_DO_52
DDR A D53	AJ6	SA_DO_53
DDR A D54	AT5	SA_DO_54
DDR A D55	AN10	SA_DO_55
DDR A D56	AM11	SA_DO_56
DDR A D57	AM5	SA_DO_57
DDR A D58	AJ9	SA_DO_58
DDR A D59	AJ8	SA_DO_59
DDR A D60	AM12	SA_DO_60
DDR A D61	AM13	SA_DO_61
DDR A D62	AJ11	SA_DO_62
DDR A D63	AJ12	SA_DO_63

U12D

DDR SYSTEM MEMORY A

SA_BS_0	BD21	DDR A BS0
SA_BS_1	RG18	DDR A BS1
SA_BS_2	AT25	DDR A BS2
SA_RAS#	BB20	DDR A RAS#
SA_CAS#	BD20	DDR A CAS#
SA_WE#	AY20	DDR A WE#
SA_DM_0	AM37	DDR A DM0
SA_DM_1	AT41	DDR A DM1
SA_DM_2	AY41	DDR A DM2
SA_DM_3	AU39	DDR A DM3
SA_DM_4	BB12	DDR A DM4
SA_DM_5	AY6	DDR A DM5
SA_DM_6	AT7	DDR A DM6
SA_DM_7	AJ5	DDR A DM7
SA_DQS_0	AJ44	DDR A DQS0
SA_DQS_1	AT44	DDR A DQS1
SA_DQS_2	BA43	DDR A DQS2
SA_DQS_3	BC37	DDR A DQS3
SA_DQS_4	AW12	DDR A DQS4
SA_DQS_5	BC8	DDR A DQS5
SA_DQS_6	AJ8	DDR A DQS6
SA_DQS_7	AM7	DDR A DQS7
SA_DQS#_0	AJ43	DDR A DQS#0
SA_DQS#_1	AT43	DDR A DQS#1
SA_DQS#_2	BA44	DDR A DQS#2
SA_DQS#_3	RD37	DDR A DQS#3
SA_DQS#_4	AY42	DDR A DQS#4
SA_DQS#_5	BD9	DDR A DQS#5
SA_DQS#_6	AJ9	DDR A DQS#6
SA_DQS#_7	AM8	DDR A DQS#7
SA_MA_0	BA21	DDR A MA0
SA_MA_1	BC24	DDR A MA2
SA_MA_2	BG24	DDR A MA3
SA_MA_3	RG25	DDR A MA4
SA_MA_4	BA24	DDR A MA5
SA_MA_5	RD24	DDR A MA6
SA_MA_6	BG27	DDR A MA7
SA_MA_7	BF25	DDR A MA8
SA_MA_8	AW24	DDR A MA9
SA_MA_9	RC21	DDR A MA10
SA_MA_10	RG26	DDR A MA11
SA_MA_11	BH26	DDR A MA12
SA_MA_12	BH17	DDR A MA13
SA_MA_13	AY25	DDR A MA14
SA_MA_14		

CANTIGA_tp0

[15] DDR_B_D[0..63]

DDR B D0	AK47	SB_DO_0
DDR B D1	AH46	SB_DO_1
DDR B D2	AP47	SB_DO_2
DDR B D3	AP46	SB_DO_3
DDR B D4	AJ46	SB_DO_4
DDR B D5	AJ48	SB_DO_5
DDR B D6	AM48	SB_DO_6
DDR B D7	AP48	SB_DO_7
DDR B D8	AJ47	SB_DO_8
DDR B D9	AJ46	SB_DO_9
DDR B D10	AH48	SB_DO_10
DDR B D11	AT48	SB_DO_11
DDR B D12	AT47	SB_DO_12
DDR B D13	AA47	SB_DO_13
DDR B D14	AA47	SB_DO_14
DDR B D15	BC47	SB_DO_15
DDR B D16	BC46	SB_DO_16
DDR B D17	BC44	SB_DO_17
DDR B D18	BG43	SB_DO_18
DDR B D19	BF43	SB_DO_19
DDR B D20	BE46	SB_DO_20
DDR B D21	BC41	SB_DO_21
DDR B D22	BE40	SB_DO_22
DDR B D23	BE41	SB_DO_23
DDR B D24	BG38	SB_DO_24
DDR B D25	BF38	SB_DO_25
DDR B D26	BH35	SB_DO_26
DDR B D27	RG35	SB_DO_27
DDR B D28	BH40	SB_DO_28
DDR B D29	BG39	SB_DO_29
DDR B D30	BG34	SB_DO_30
DDR B D31	BH34	SB_DO_31
DDR B D32	BH14	SB_DO_32
DDR B D33	BH12	SB_DO_33
DDR B D34	BH11	SB_DO_34
DDR B D35	BH12	SB_DO_35
DDR B D36	BH18	SB_DO_36
DDR B D37	BF11	SB_DO_37
DDR B D38	BF8	SB_DO_38
DDR B D39	BG7	SB_DO_39
DDR B D40	BC5	SB_DO_40
DDR B D41	BC6	SB_DO_41
DDR B D42	AY3	SB_DO_42
DDR B D43	AY11	SB_DO_43
DDR B D44	BF6	SB_DO_44
DDR B D45	BF5	SB_DO_45
DDR B D46	BA1	SB_DO_46
DDR B D47	BD3	SB_DO_47
DDR B D48	AV2	SB_DO_48
DDR B D49	AJ13	SB_DO_49
DDR B D50	AN2	SB_DO_50
DDR B D51	AN3	SB_DO_51
DDR B D52	AY2	SB_DO_52
DDR B D53	AV1	SB_DO_53
DDR B D54	AP3	SB_DO_54
DDR B D55	AR1	SB_DO_55
DDR B D56	AL1	SB_DO_56
DDR B D57	AL2	SB_DO_57
DDR B D58	AJ1	SB_DO_58
DDR B D59	AH1	SB_DO_59
DDR B D60	AM2	SB_DO_60
DDR B D61	AM3	SB_DO_61
DDR B D62	AH3	SB_DO_62
DDR B D63	AJ3	SB_DO_63

U12E

DDR SYSTEM MEMORY B

SB_BS_0	BC16	DDR B BS0
SB_BS_1	BB17	DDR B BS1
SB_BS_2	BB33	DDR B BS2
SB_RAS#	AJ17	DDR B RAS#
SB_CAS#	BG16	DDR B CAS#
SB_WE#	BF14	DDR B WE#
SB_DM_0	AM47	DDR B DM0
SB_DM_1	AY47	DDR B DM1
SB_DM_2	BD40	DDR B DM2
SB_DM_3	BF35	DDR B DM3
SB_DM_4	RG11	DDR B DM4
SB_DM_5	BA3	DDR B DM5
SB_DM_6	AP1	DDR B DM6
SB_DM_7	AK2	DDR B DM7
SB_DQS_0	AL47	DDR B DQS0
SB_DQS_1	AV48	DDR B DQS1
SB_DQS_2	BG41	DDR B DQS2
SB_DQS_3	BG37	DDR B DQS3
SB_DQS_4	BH9	DDR B DQS4
SB_DQS_5	BB2	DDR B DQS5
SB_DQS_6	AJ11	DDR B DQS6
SB_DQS_7	AN6	DDR B DQS7
SB_DQS#_0	AL46	DDR B DQS#0
SB_DQS#_1	AV47	DDR B DQS#1
SB_DQS#_2	BH41	DDR B DQS#2
SB_DQS#_3	BH37	DDR B DQS#3
SB_DQS#_4	BC2	DDR B DQS#4
SB_DQS#_5	AT2	DDR B DQS#5
SB_DQS#_6	AN5	DDR B DQS#6
SB_DQS#_7	AN5	DDR B DQS#7
SB_MA_0	AV17	DDR B MA0
SB_MA_1	BA25	DDR B MA1
SB_MA_2	BC25	DDR B MA2
SB_MA_3	AU25	DDR B MA3
SB_MA_4	AW25	DDR B MA4
SB_MA_5	BB28	DDR B MA5
SB_MA_6	AU28	DDR B MA6
SB_MA_7	AW28	DDR B MA7
SB_MA_8	AT33	DDR B MA8
SB_MA_9	BD33	DDR B MA9
SB_MA_10	BB16	DDR B MA10
SB_MA_11	AW33	DDR B MA11
SB_MA_12	AY33	DDR B MA12
SB_MA_13	BH15	DDR B MA13
SB_MA_14	AU33	DDR B MA14

CANTIGA_tp0

QUANTA COMPUTER

File: Cantiga (DDR2)

Size	Document Number	Rev
	VM8G	1B

Date: Saturday, June 06, 2009 Sheet 7 of 53

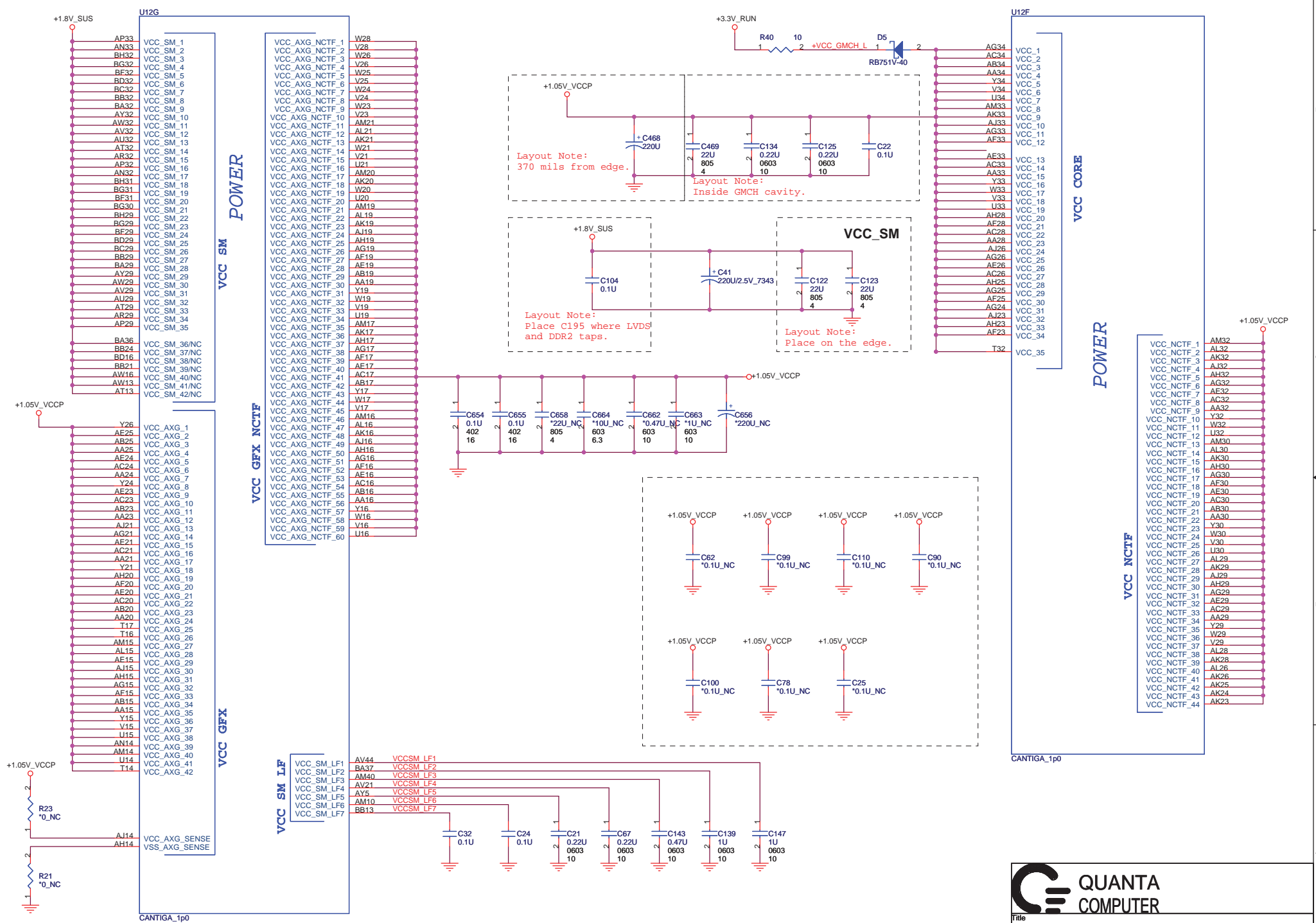

CANTIGA_1p0
 U12G
 U12F
 CANTIGA_1p0

LIMA: Places R21, R23 to 10 ohm
 Dis: Please R21, R23 to 0 ohm.

QUANTA COMPUTER

Title: Cantiga (VCC,NCTF)

Size	Document Number	Rev
	VMBG	1B

Date: Saturday, June 06, 2009 Sheet 8 of 53

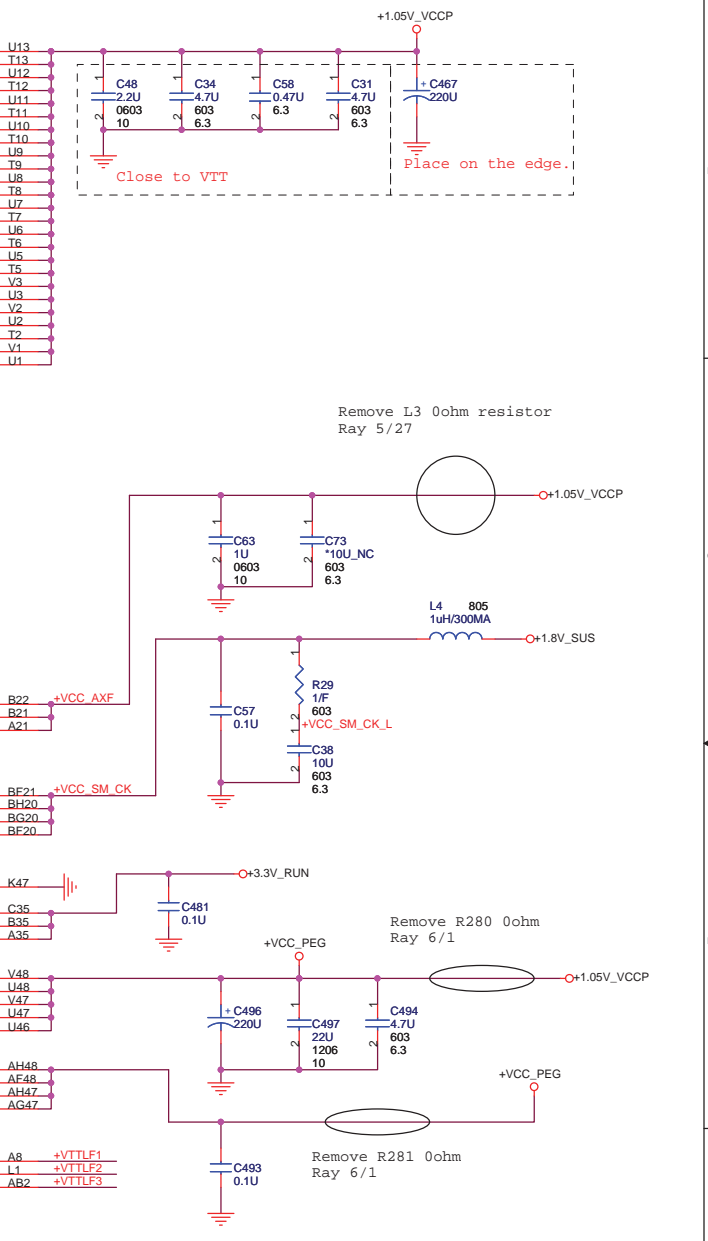
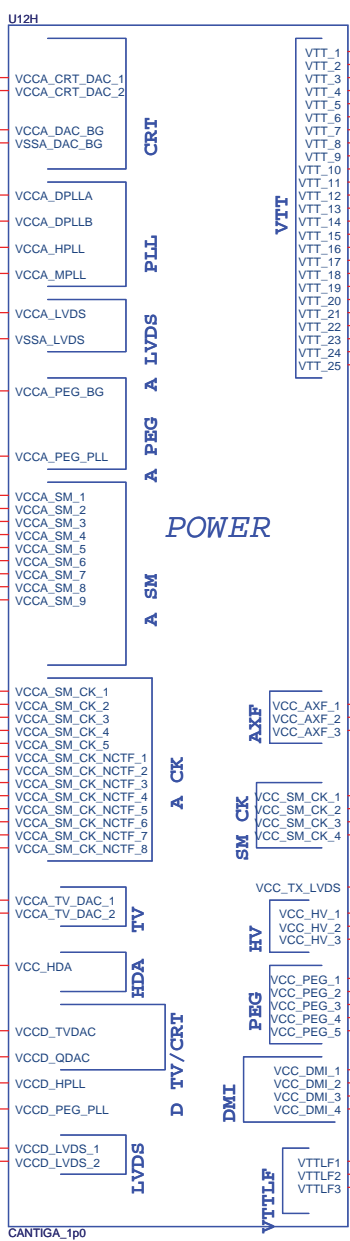
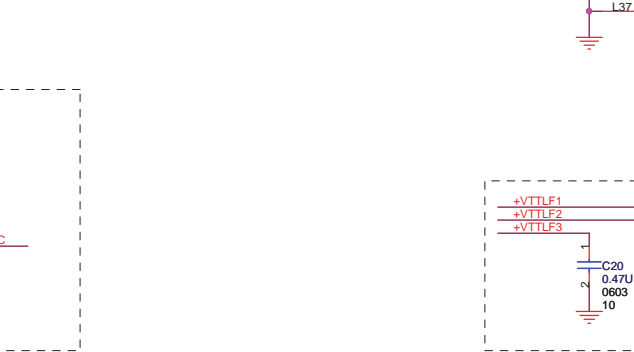
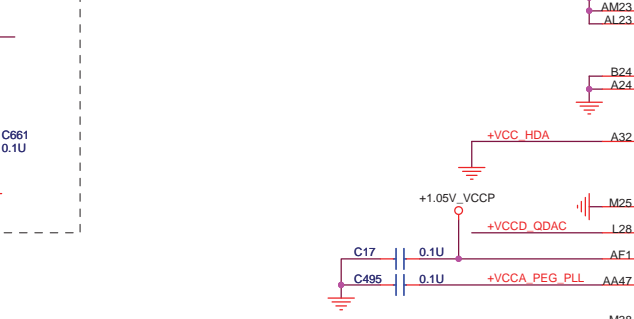
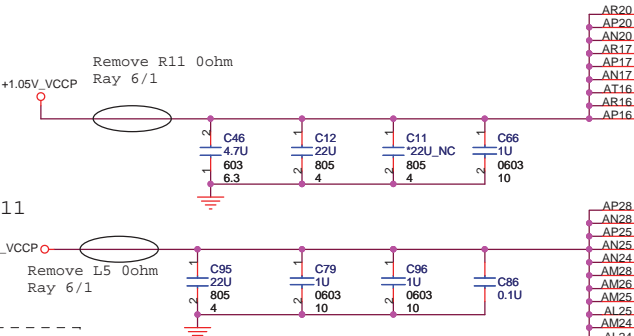
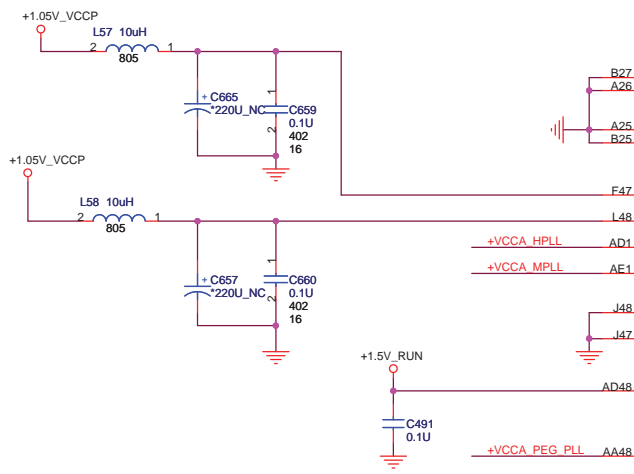
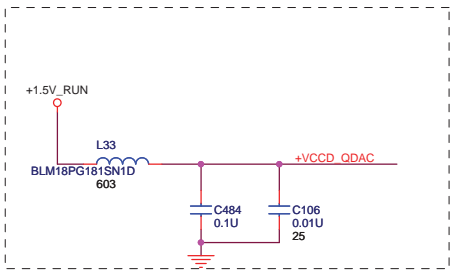
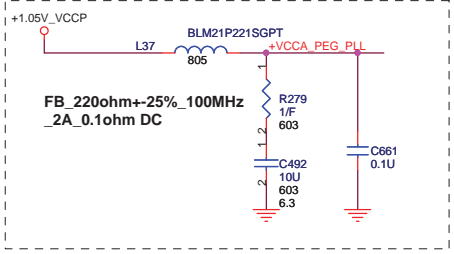
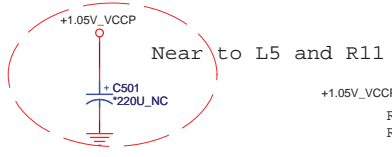
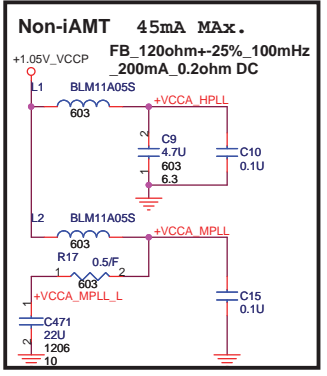

QUANTA COMPUTER

File: Cantiga (POWER)

Size	Document Number VM8G	Rev	1B
Date:	Saturday, June 06, 2009	Sheet	9 of 53

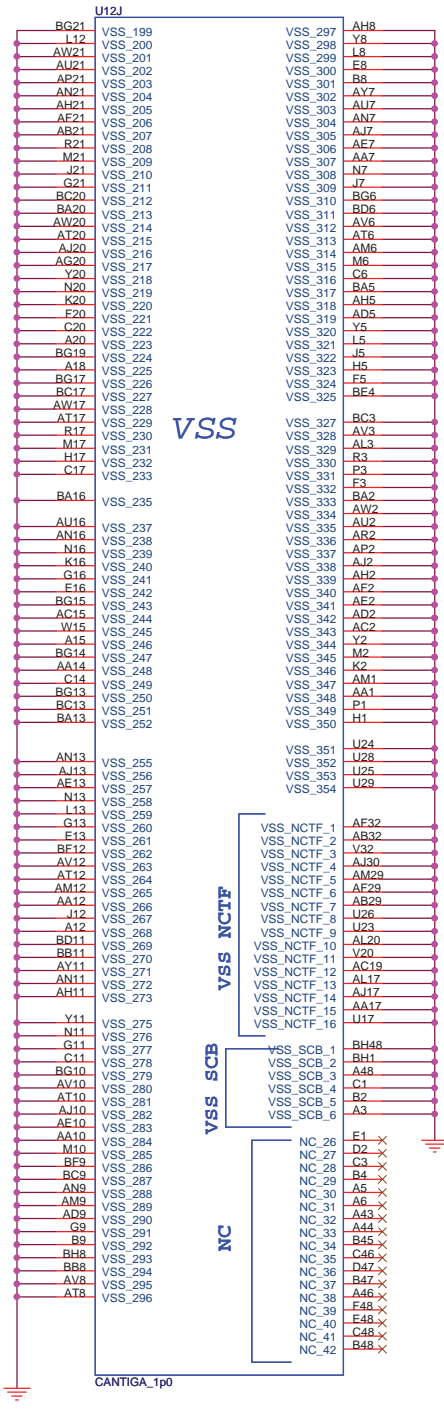
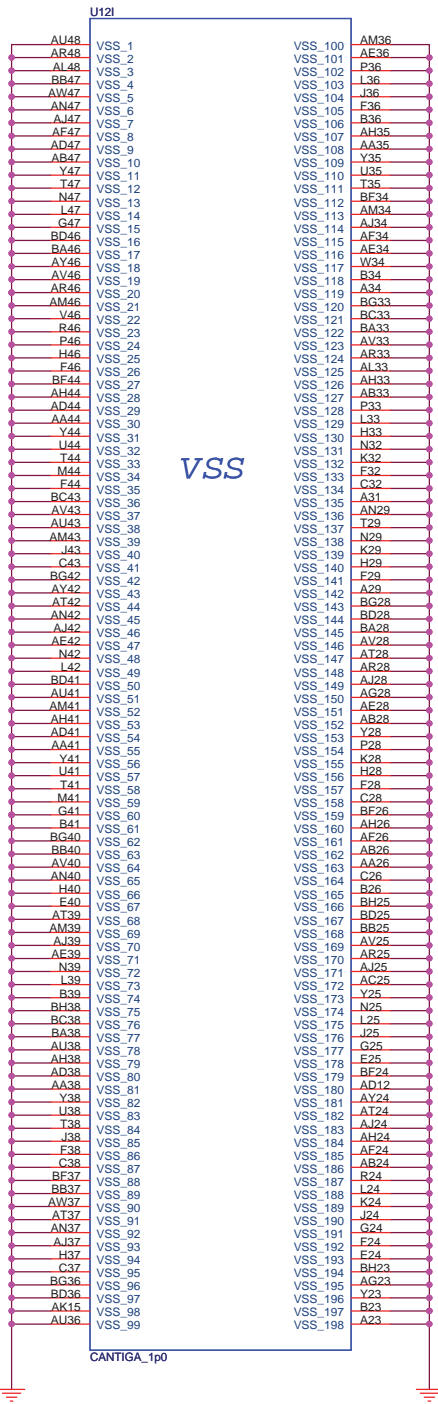

**QUANTA
COMPUTER**

File: Cantiga (VSS)		
Size: VM6G	Document Number: VM6G	Rev: 1B
Date: Saturday, June 06, 2009	Sheet: 10	of 53

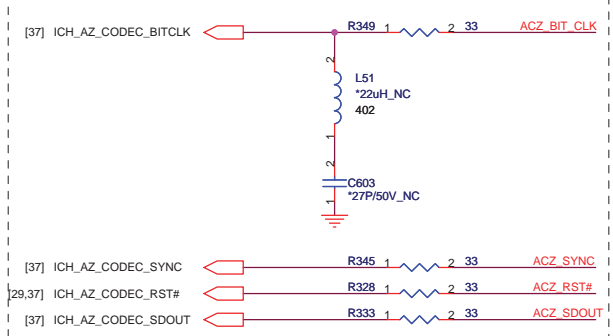
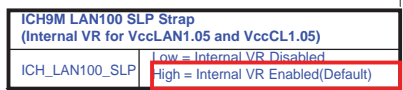
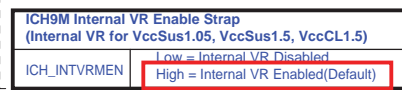
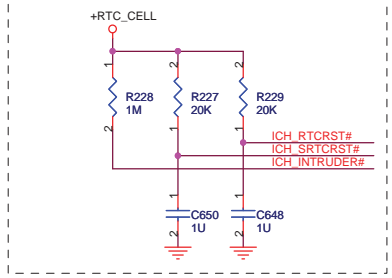
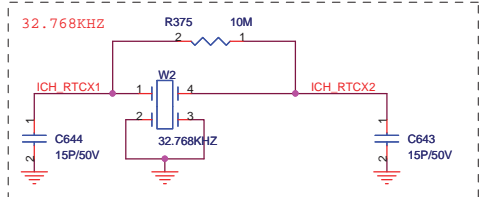

Place all series terms close to ICH9 except for SDIN input lines, which should be close to source.

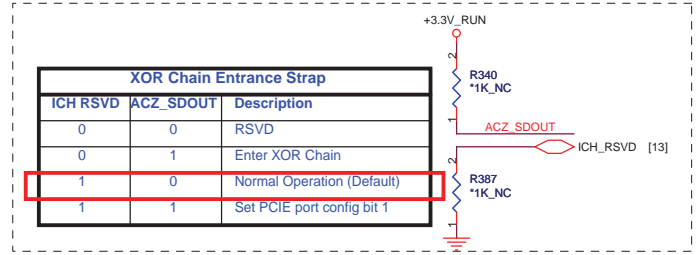
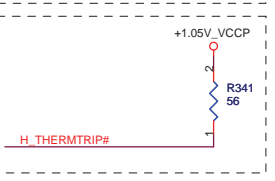
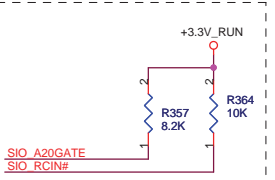
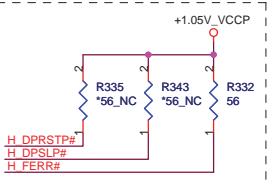
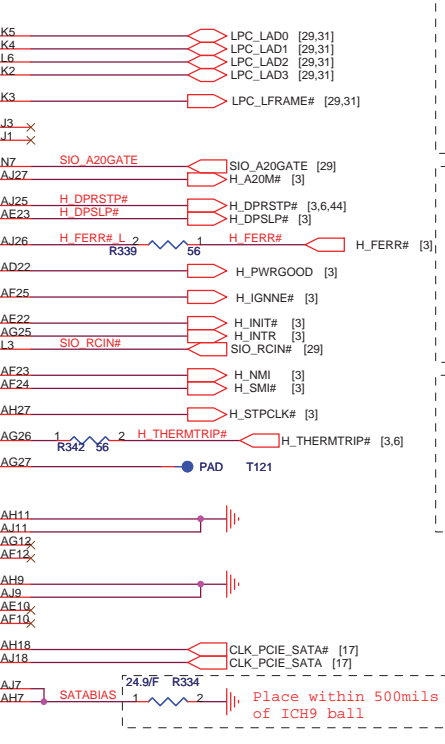
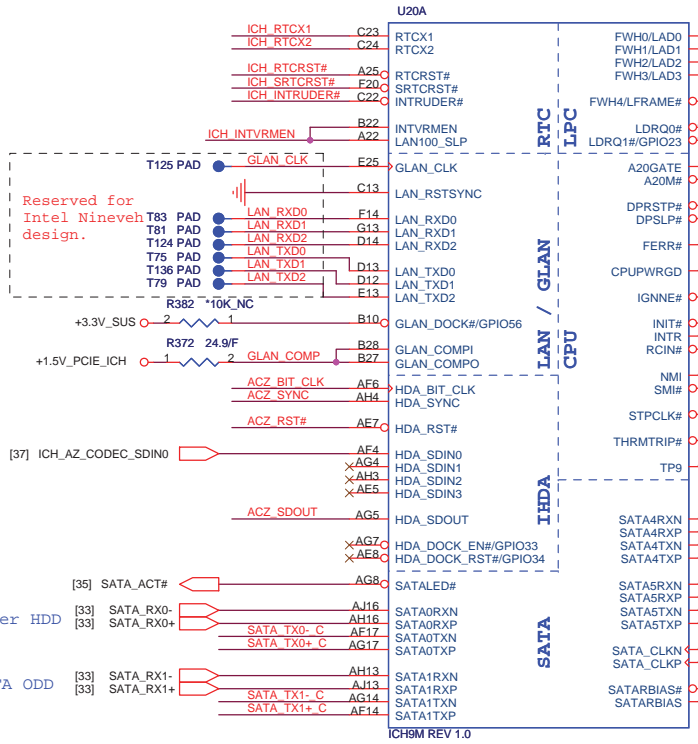
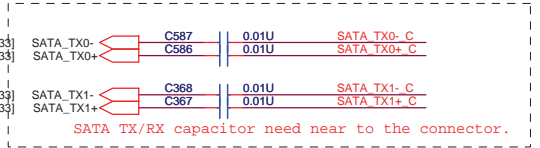

QUANTA COMPUTER

File: ICH9-M (CPU,SATA,LPC,LAN,CODEC)

Size: Document Number VM8G Rev 1B

Date: Saturday, June 06, 2009 Sheet 11 of 53

Place TX DC blocking caps close ICH9.

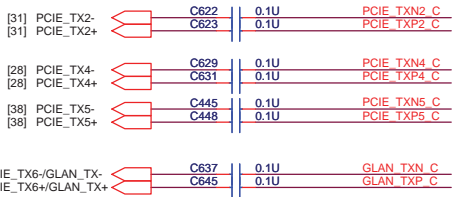

Boot BIOS Strap			
		GNT0#	SPI_CS1#
LPC	11	No stuff	No stuff
PCI	10	No stuff	Stuff
SPI	01	Stuff	No stuff

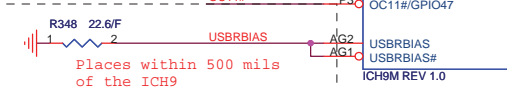
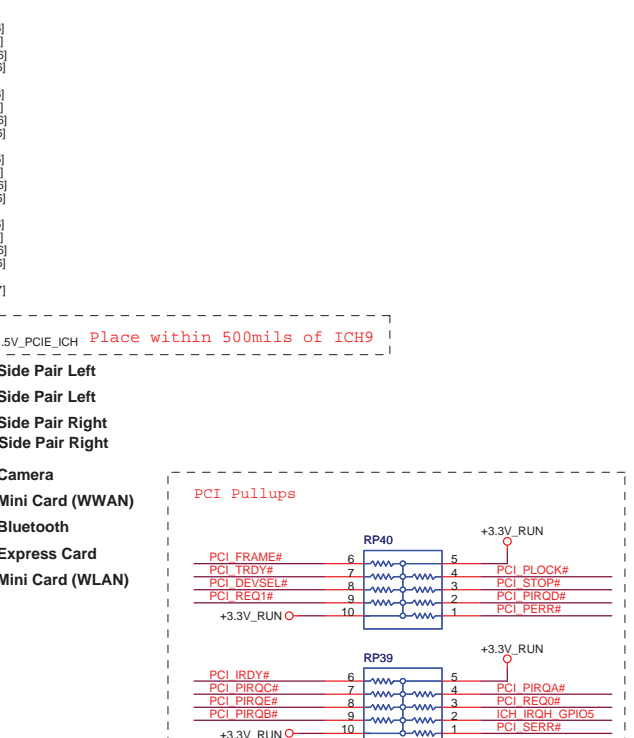
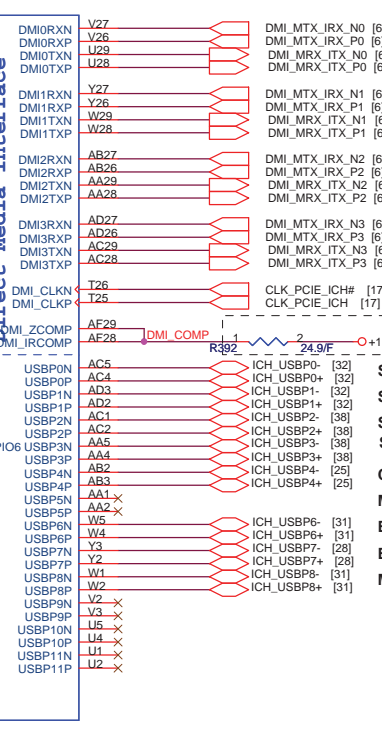
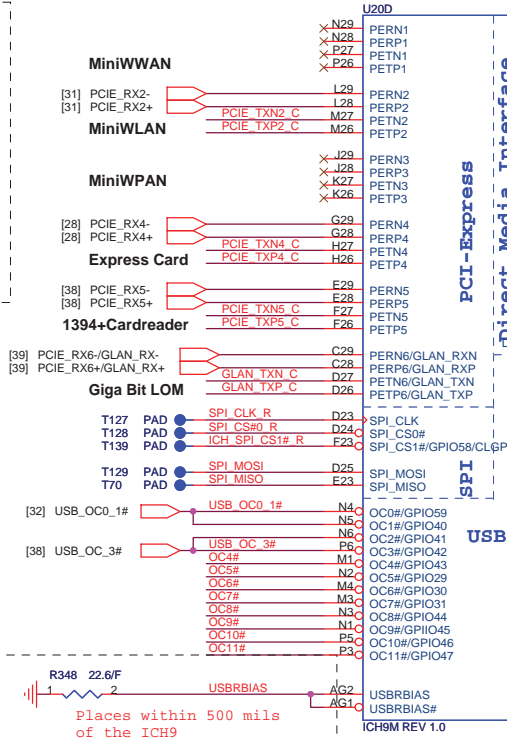
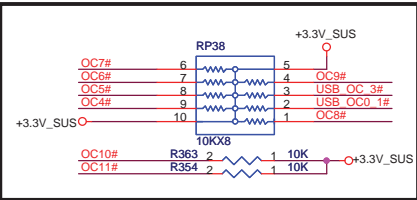

- Side Pair Left
- Side Pair Left
- Side Pair Right
- Side Pair Right
- Camera
- Mini Card (WWAN)
- Bluetooth
- Express Card
- Mini Card (WLAN)

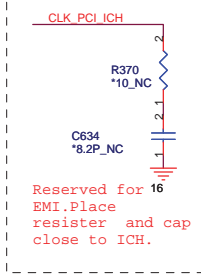
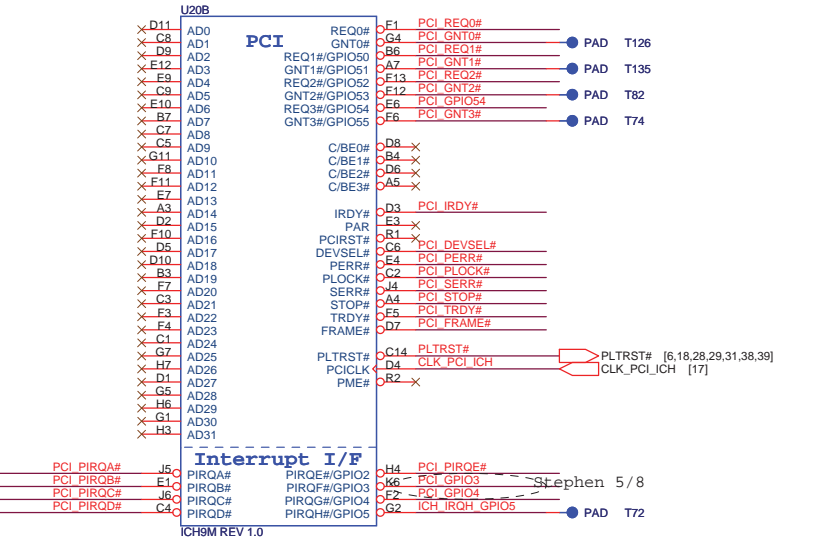
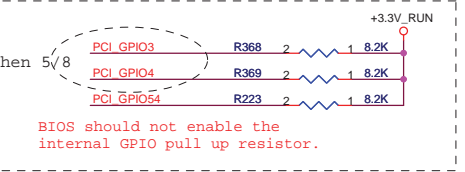
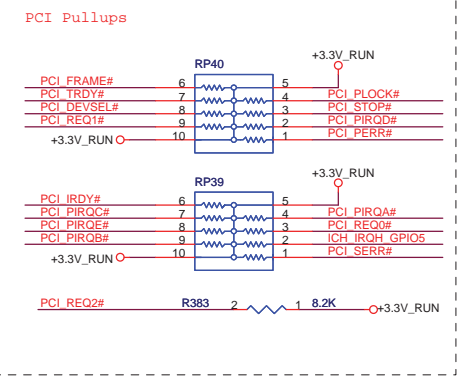

QUANTA COMPUTER

File: ICH9-M (USB,DMI,PCIE,PCI)

Size: Document Number VMBG

Date: Saturday, June 06, 2009

Sheet: 12 of 53

Rev: 1B

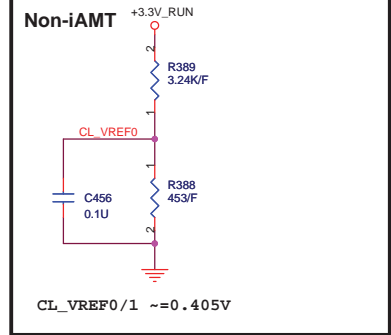
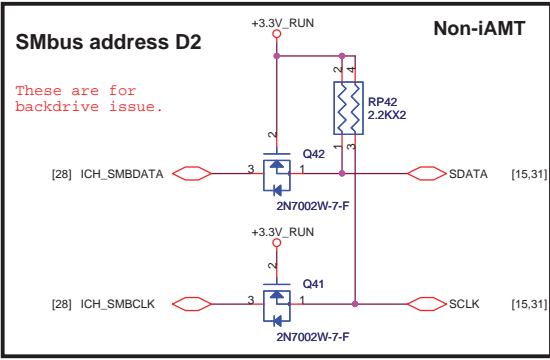
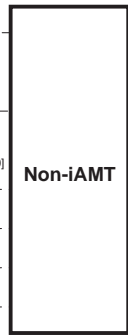
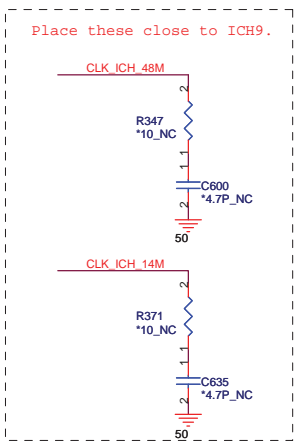
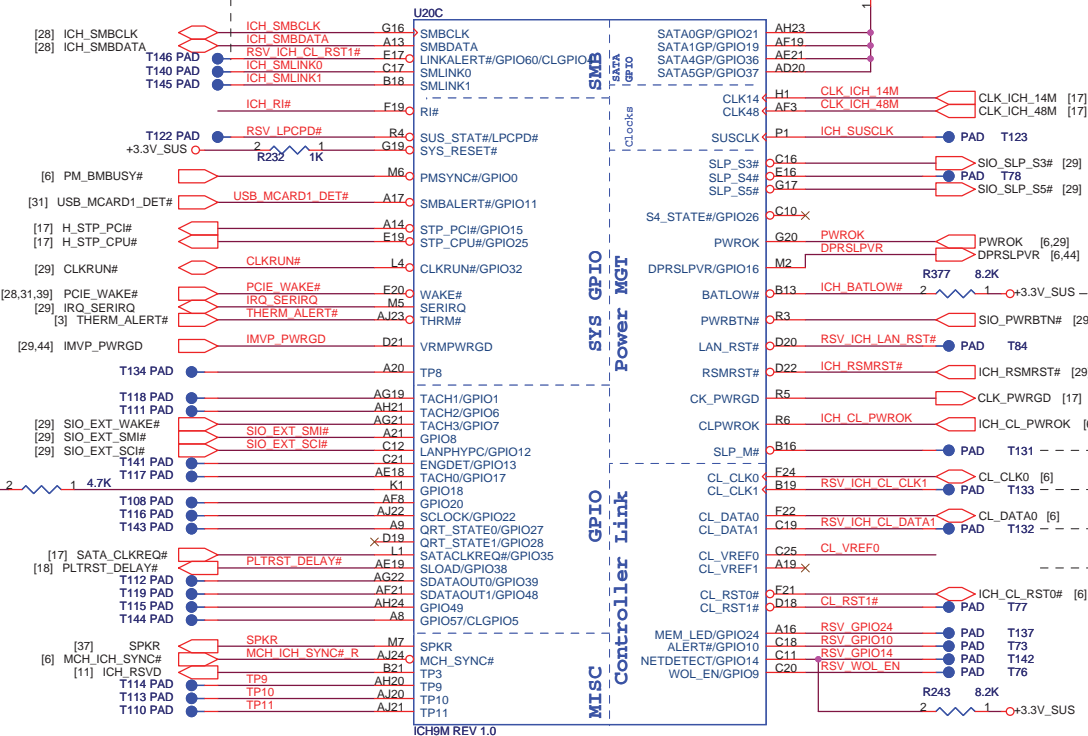
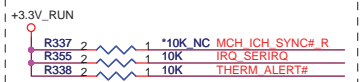
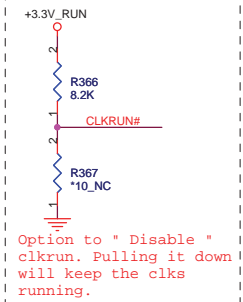
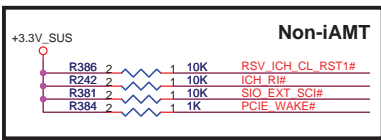
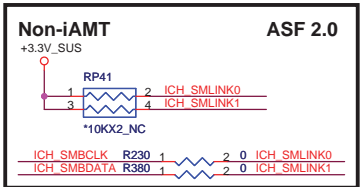
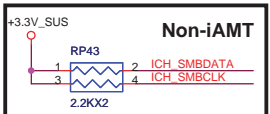

QUANTA COMPUTER

File: ICH9-M (PM,GPIO,SMB,CL)

Size: Document Number VM8G Rev 1B

Date: Saturday, June 06, 2009 Sheet 13 of 53

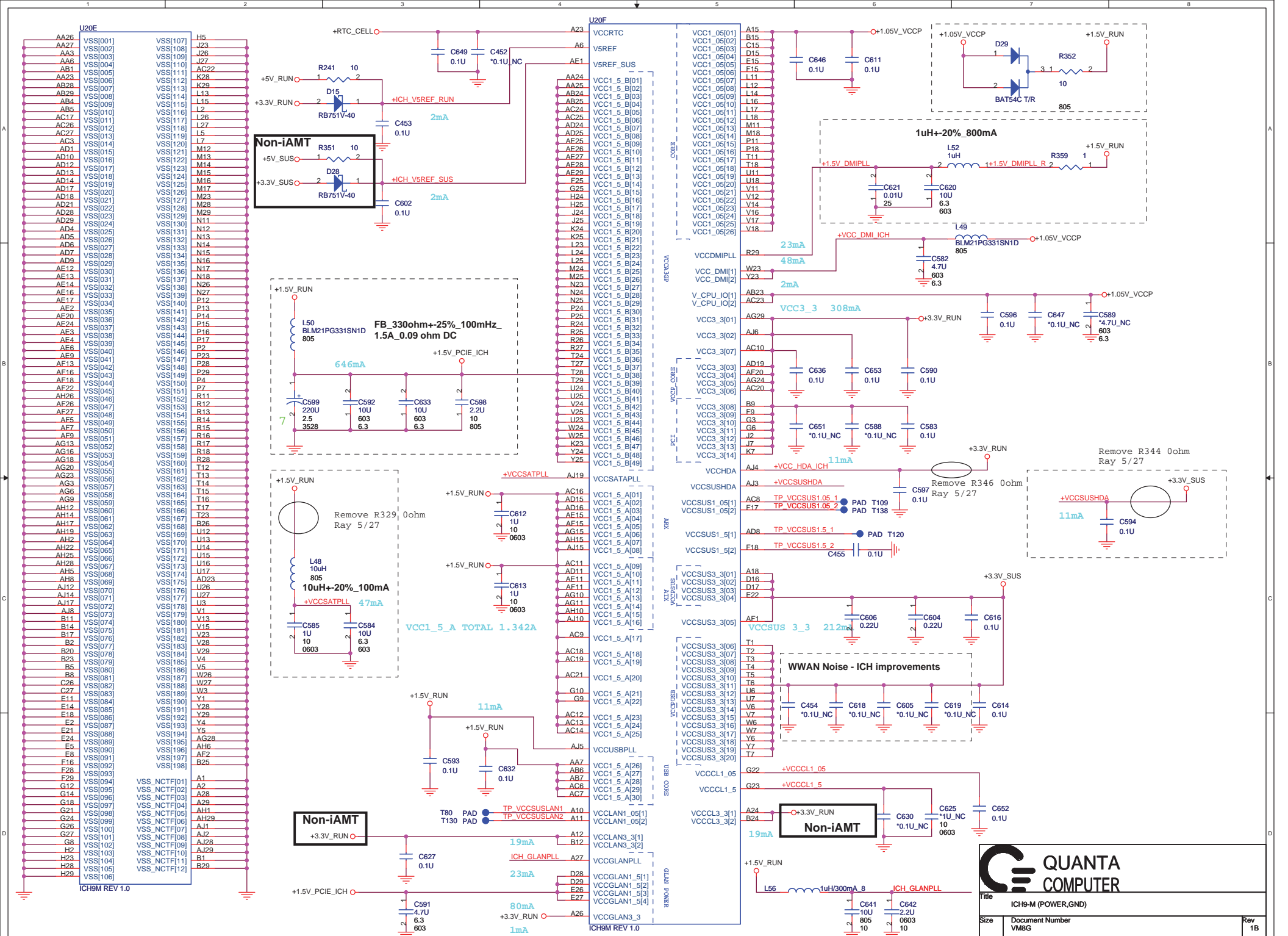

<http://laptop-motherboard-schematic.blogspot.com/>

**QUANTA
COMPUTER**

Title: ICH9-M (POWER,GND)

Size	Document Number	Rev
	VM8G	1B

Date: Saturday, June 06, 2009 Sheet 14 of 53

A is required to route to Top SoDIMM for AMTto function. Ch.A SODIMM needs to be populated for Intel AMT support.

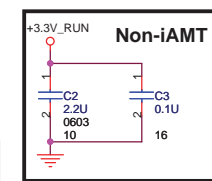
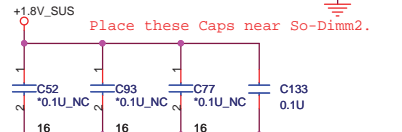
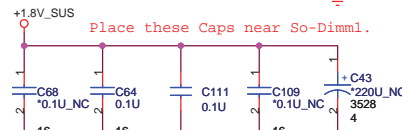
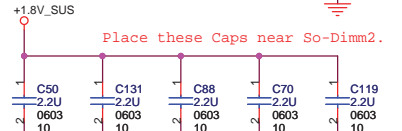
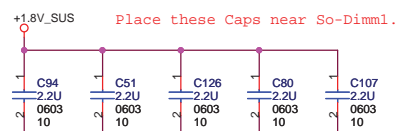
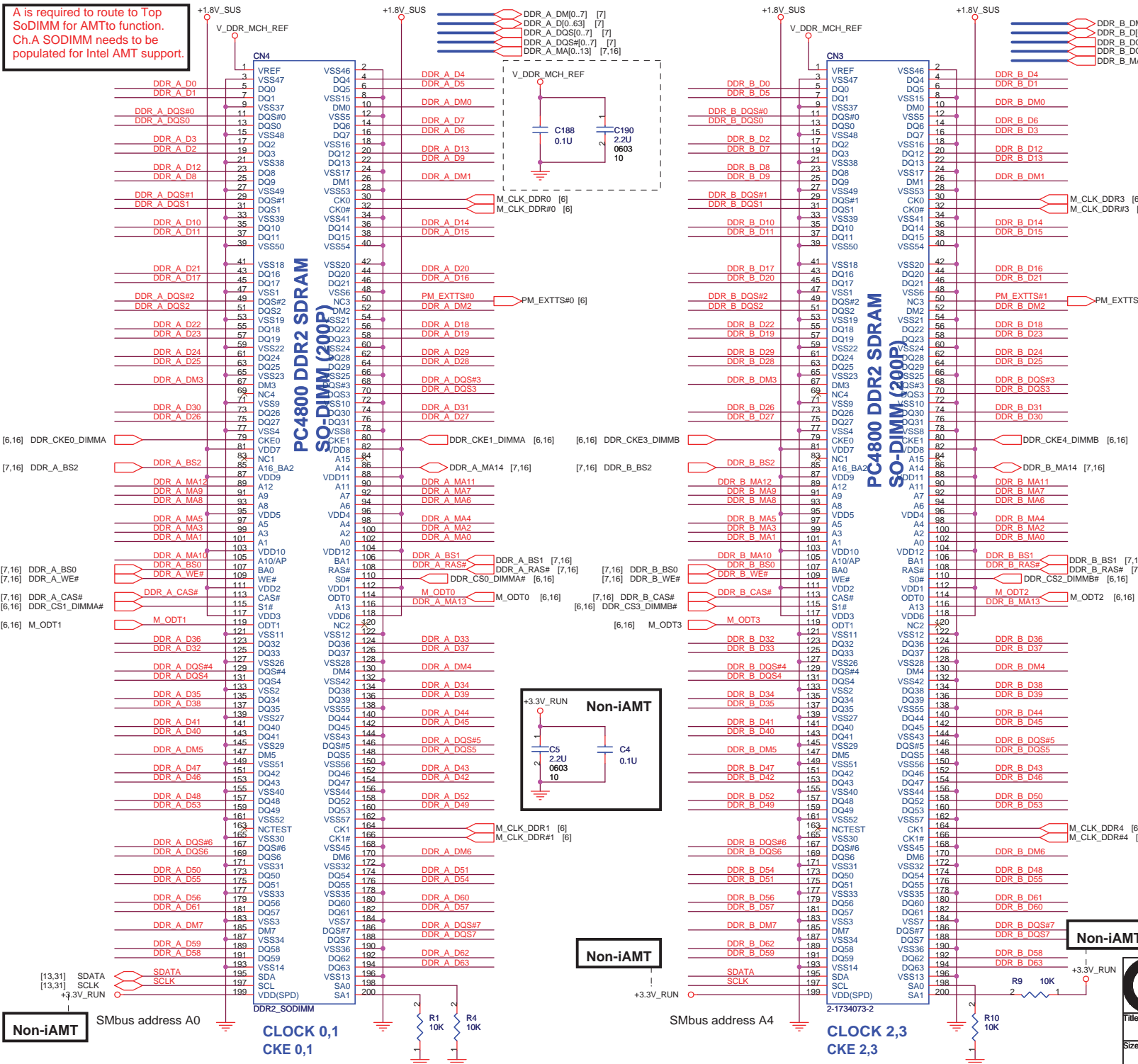

		DDR2 SO-DIMM (200P) X 2		Rev 1B
Date:	Tuesday, June 02, 2009	Sheet	15	of 53

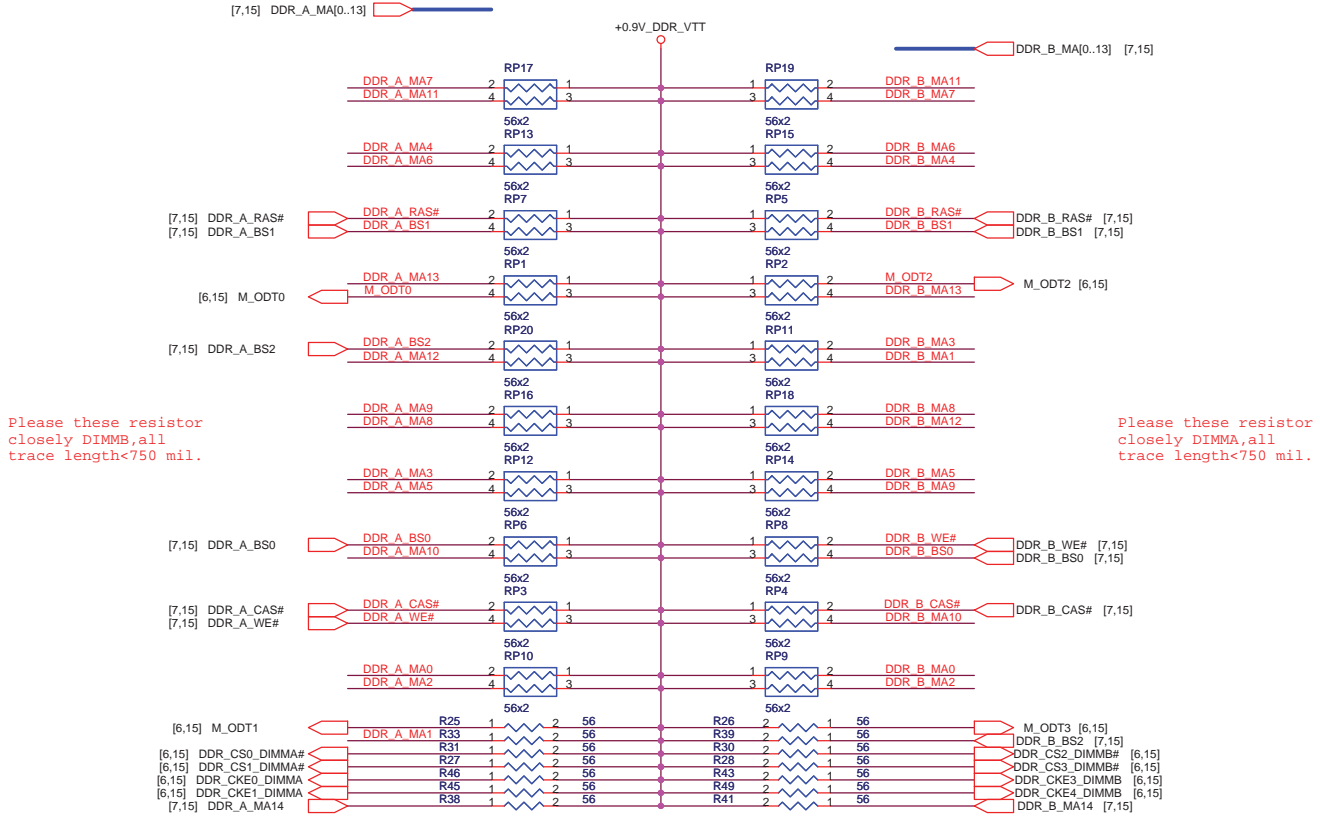
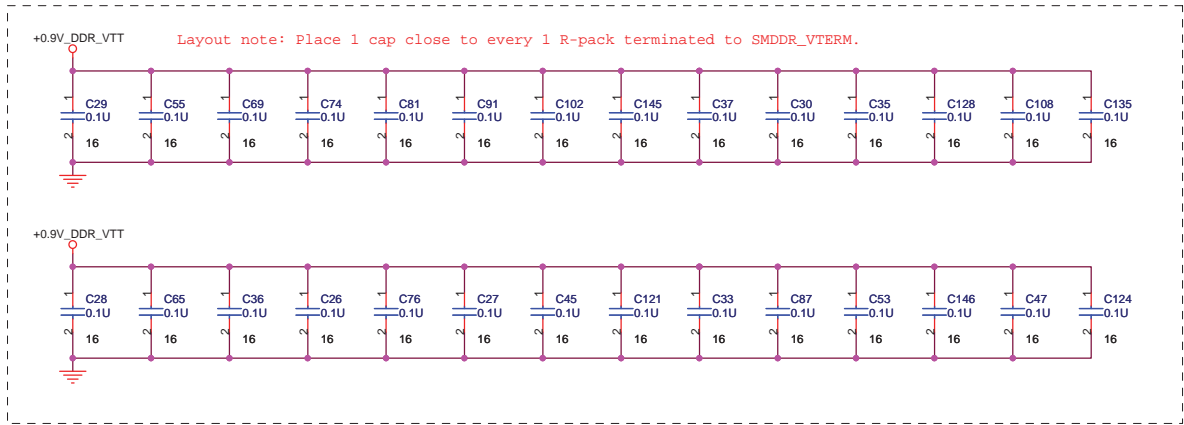

**QUANTA
COMPUTER**

File: **DDR2 RES ARRAY**

Size	Document Number VM8G	Rev 1B
Date:	Tuesday, June 02, 2009	Sheet 16 of 53

Add capacitor pads for improving WWAN.

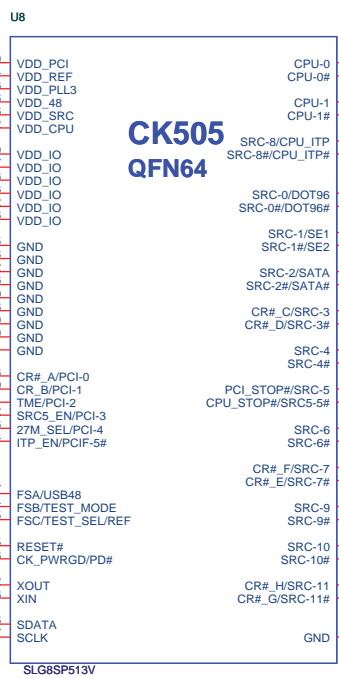
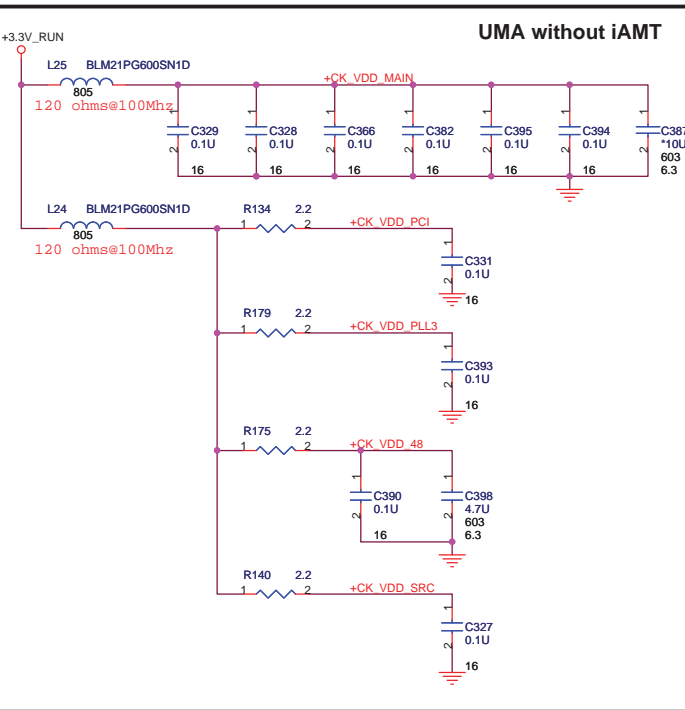
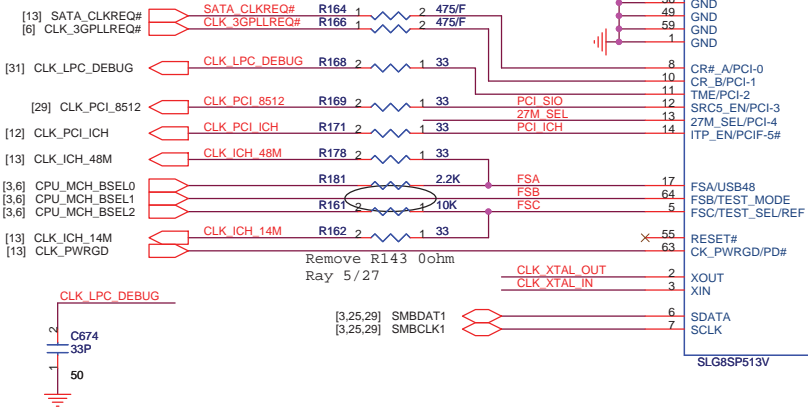
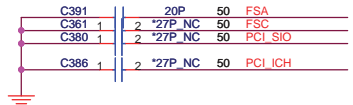

ITP_EN

PCI_ICH	10K-pull
0	Disable
1	Enable

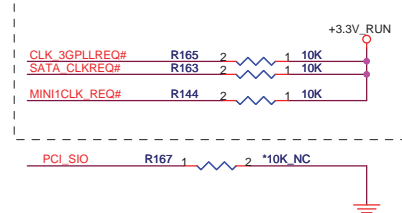
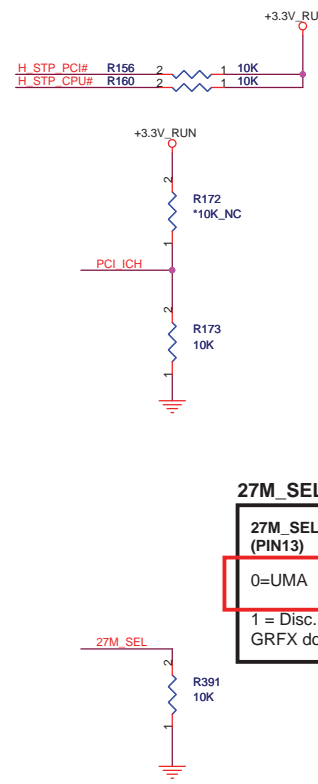

FSC	FSB	FSA	CPU	SRC	PCI
1	0	1	100	100	33
0	0	1	133	100	33
0	1	1	166	100	33
0	0	0	200	100	33
0	0	0	266	100	33
1	0	0	333	100	33
1	1	0	400	100	33
1	1	1	RSVD	100	33

27M_SEL

27M_SEL (PIN13)	PIN20	PIN21	PIN24	PIN25
0=UMA	DOT96T	DOT96C	96/100M_T	96/100M_C
1 = Disc. GRFX down	SRCT0	SRCC0	27Mout	27MSSout

[6] PCIE_MTX_GRX_P[0..15]
 [6] PCIE_MTX_GRX_N[0..15]

[6] PCIE_MRX_GTX_P[0..15]
 [6] PCIE_MRX_GTX_N[0..15]

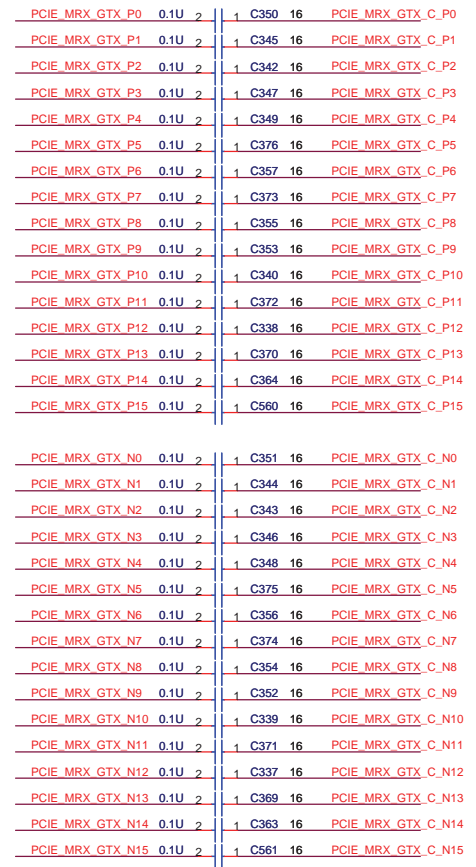
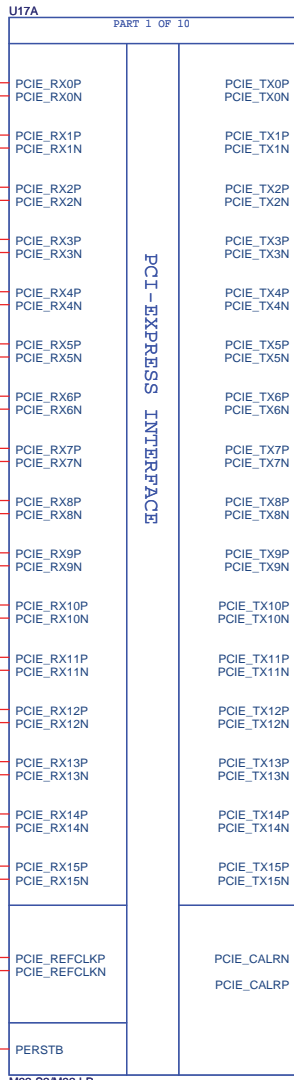

100 MHz (+/-300 ppm) input frequency, 0-0.7 V single-ended swing.
 clock must be provided less than 400ns
 after CLKREQ# is asserted

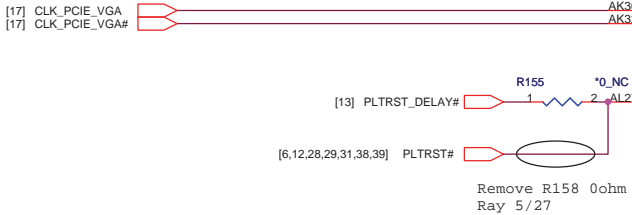

QUANTA COMPUTER

File: M92-S2_PCIE

Size	Document Number VM8G	Rev 1B
Date:	Tuesday, June 02, 2009	Sheet 18 of 53

MEMORY APERTURE SIZE SELECT				
MEMORY SIZE	CFG3 GPIO9	CFG2 GPIO13	CFG1 GPIO12	CFG0 GPIO11
128MB	0	0	0	0
256MB	0	0	1	1
64MB	0	1	1	0
512MB	1	0	0	0

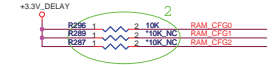

GPIO Straps table	DESCRIPTION OF DEFAULT SETTINGS	FMS setting
GPIO0	GPIO0 - TX_PWRS_ENB (Transmitter Power Savings Enable) 0: SPS Tx output swing for mobile mode 1: full Tx output swing (Default setting for Desktop)	0
GPIO1	GPIO1 - TX_DEEMPH_EN (Transmitter De-emphasis Enable) 0: Tx de-emphasis disabled for mobile mode 1: Tx de-emphasis enabled (Default setting for Desktop)	0
GPIO2	GPIO2 - RIF_GEN0_EN (5.0G76 Enable) 0: Default (Driver Controlled Gen2) 1: Strap Controlled Gen2	0
GPIO3	ATI reserved configuration straps.	0
GPIO4	ATI reserved configuration straps.	0
GPIO5	GPIO 5, AC, BATT 0: Battery saving mode = 0.0 V 1: AC (Performance mode) = 3.3 V	0
GPIO6	ATI Internal use only	0

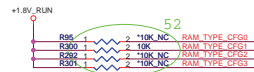
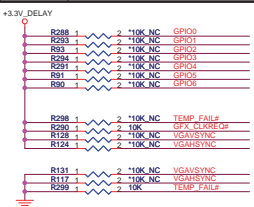

Memory Straps	RAM_CFG3	RAM_CFG2	RAM_CFG1	RAM_CFG0	Quanta PN (QuantaBuy)	Vendor PN
500MHz 512MB(64M*16) Hynix	0	0	1	0	AKD5LG-TW01(FR)	H5PS1G63EFR-20L
Remove Qionda Source						
500MHz 512MB(64M*16) Samsung	0	0	0	1	AKD5LG-T507(IE)	K4N1G164QE-HC20
Remove						

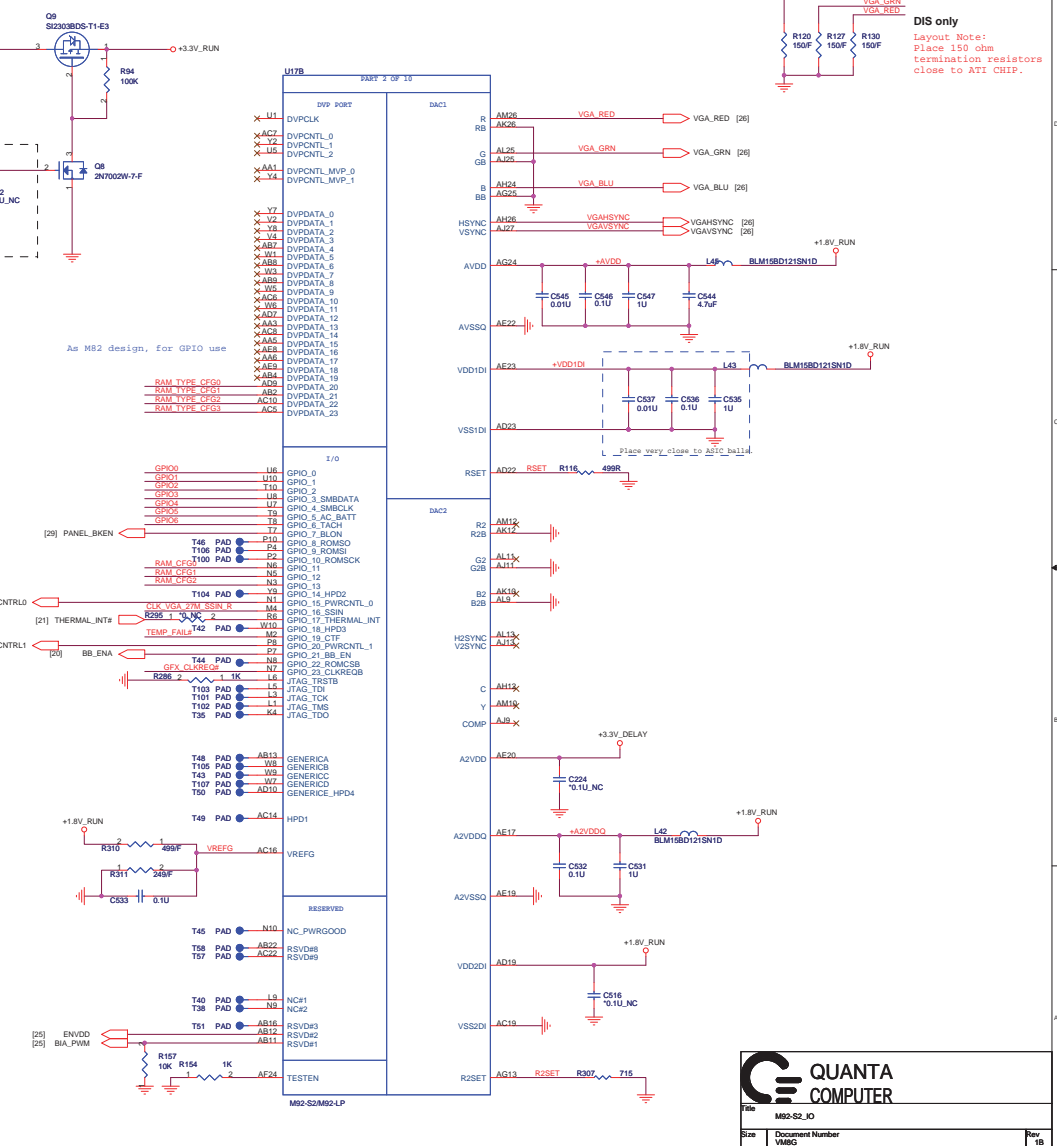
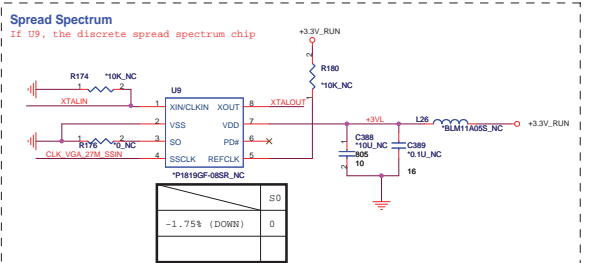
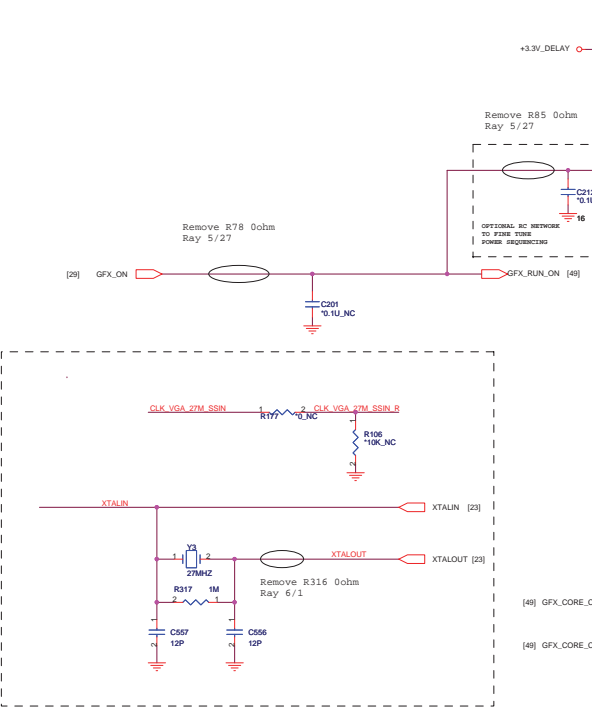

DIS only
Layout Note:
Place 150 ohm termination resistors close to ATI CHIP.

layout note: close to VDDR1#[1:17]

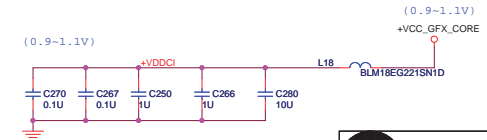
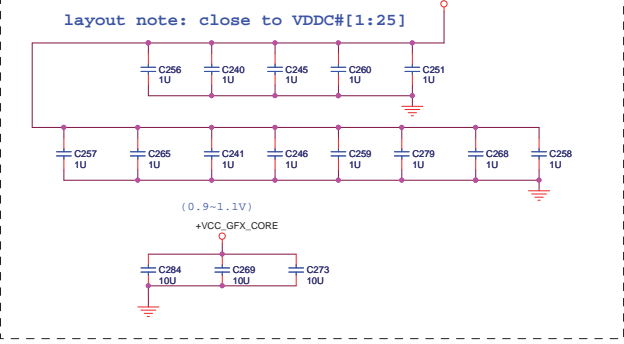
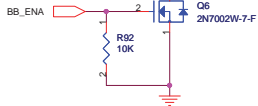
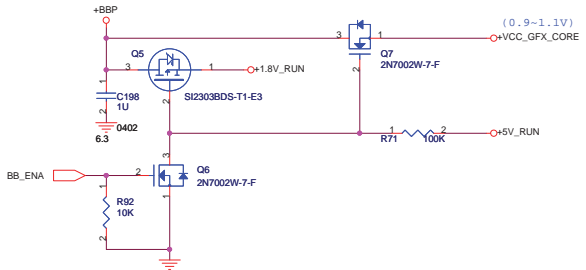
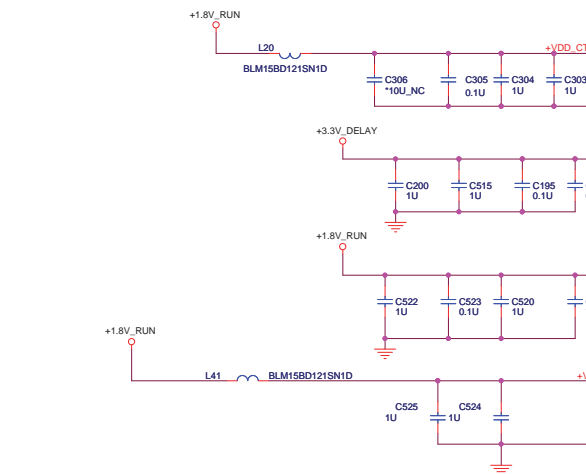
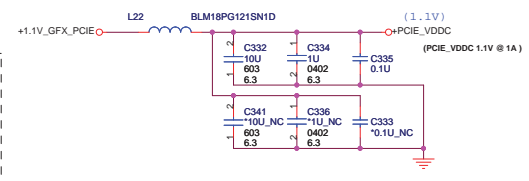
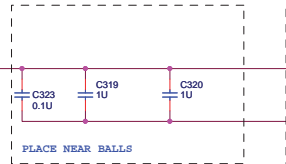
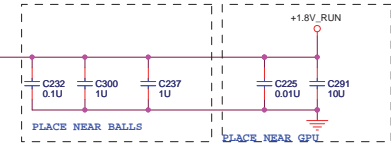
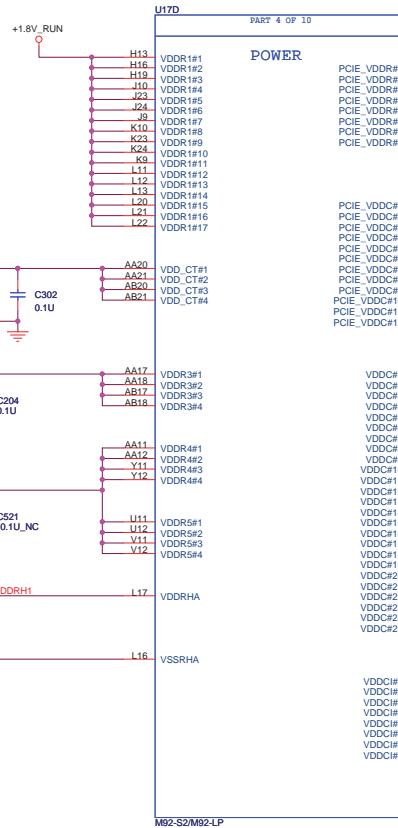
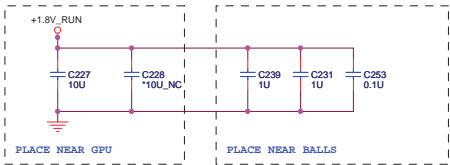

MEMORY INTERFACE

U17C PREP 3 OF 10

MEMORY INTERFACE

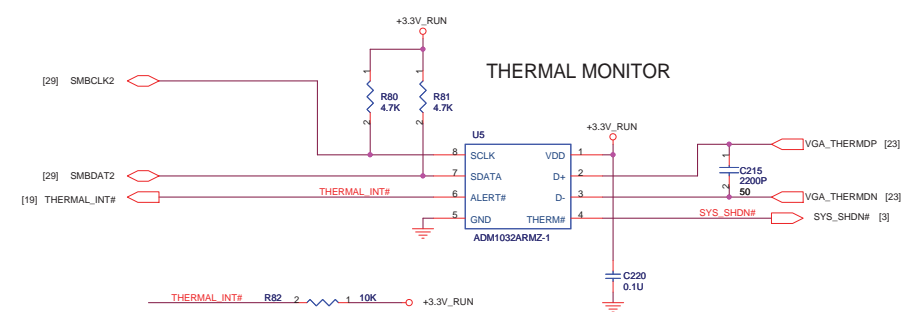
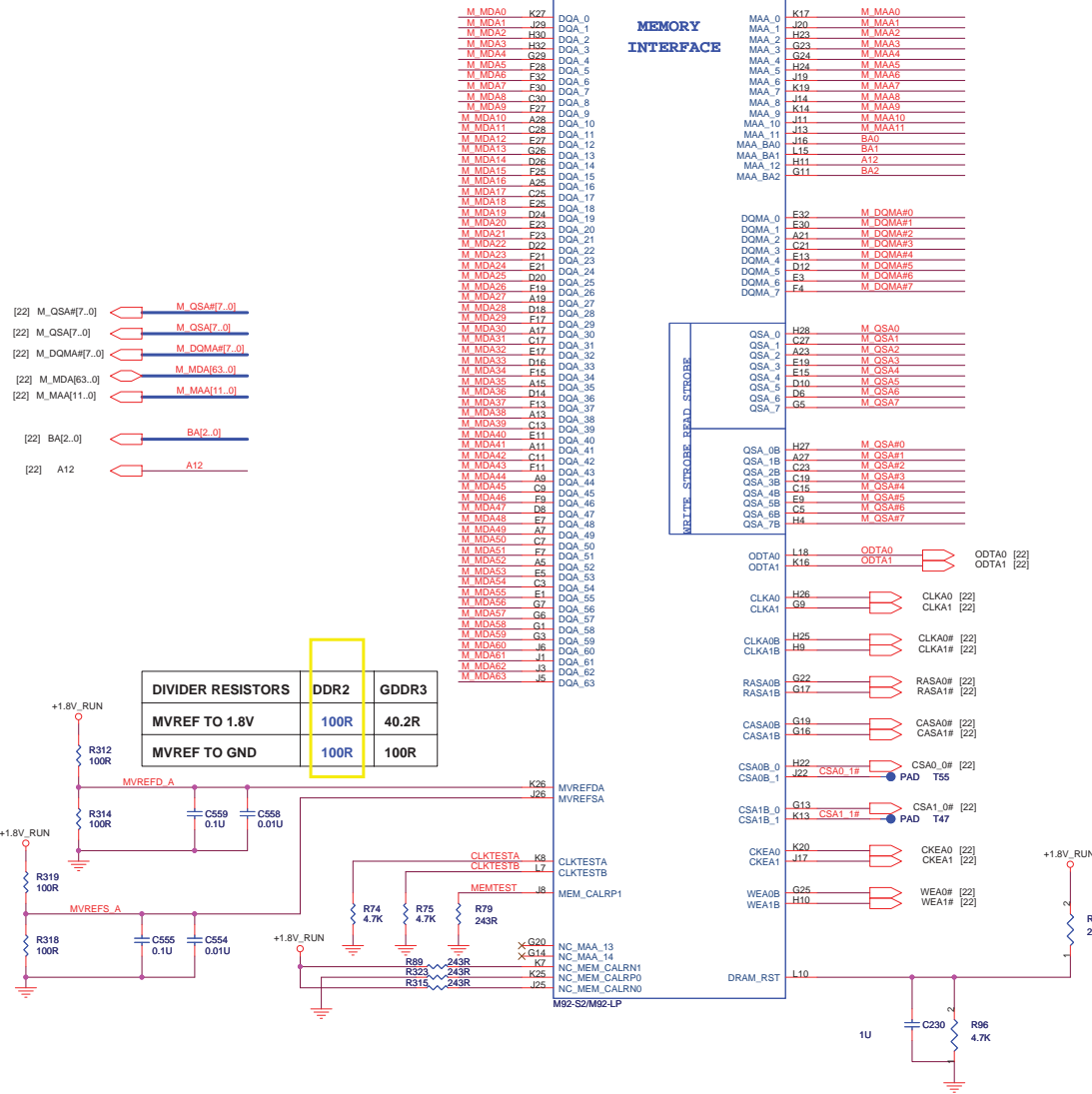

QUANTA COMPUTER

Title: MEMORY/THERM

Size: Document Number VM8G Rev 1B

Date: Tuesday, June 02, 2009 Sheet 21 of 53

DDR2 64MbitX16 MEMORY

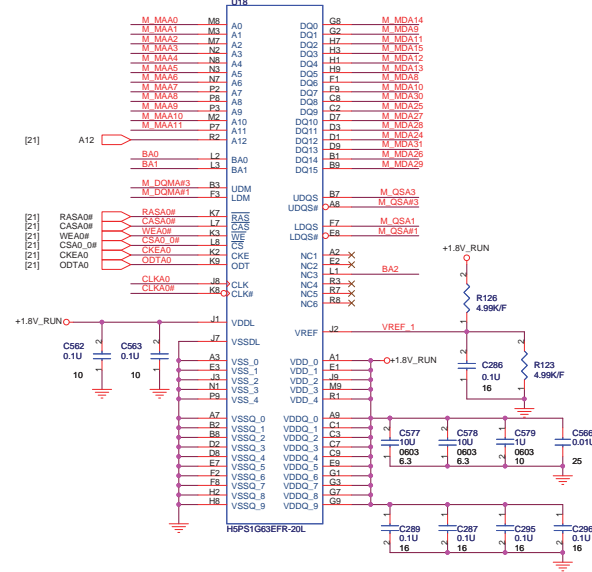
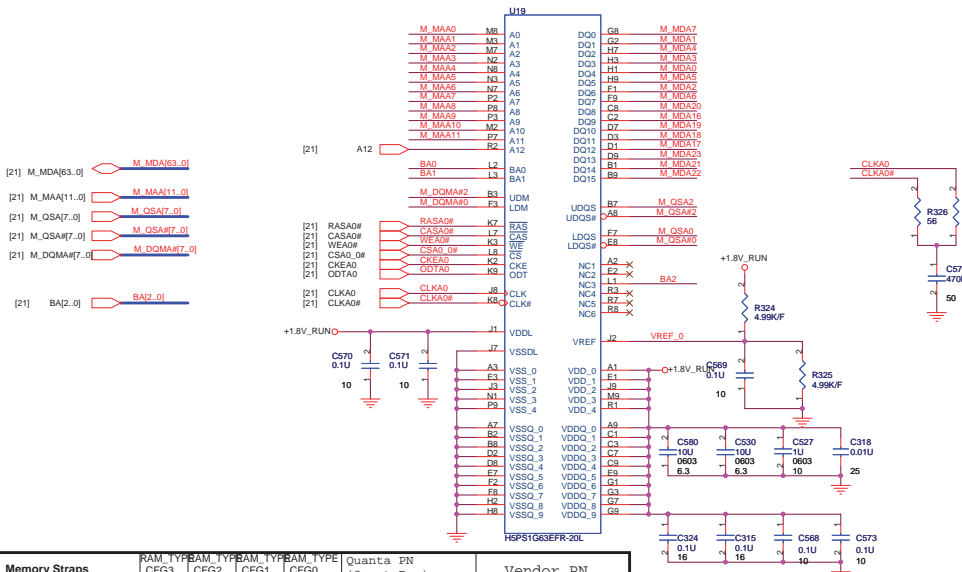

Memory Straps	RAM CFG3	TYPEAM CFG2	TYPEAM CFG1	TYPEAM CFG0	Quanta PN (QuantaBuy)	Vendor PN
500MHz 512MB(64M*16) Hynix	0	0	1	0	AKD5LG-TW01 (FR)	H5PS1G63EFR-20L
Remove Qimonda						
500MHz 512MB(64M*16) Samsung	0	0	0	1	AKD5LG-T507 (IE)	K4N1G164QE-HC20
Remove						

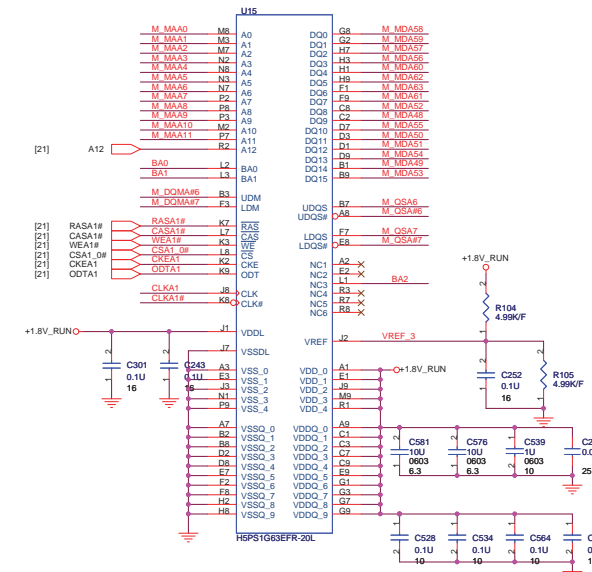
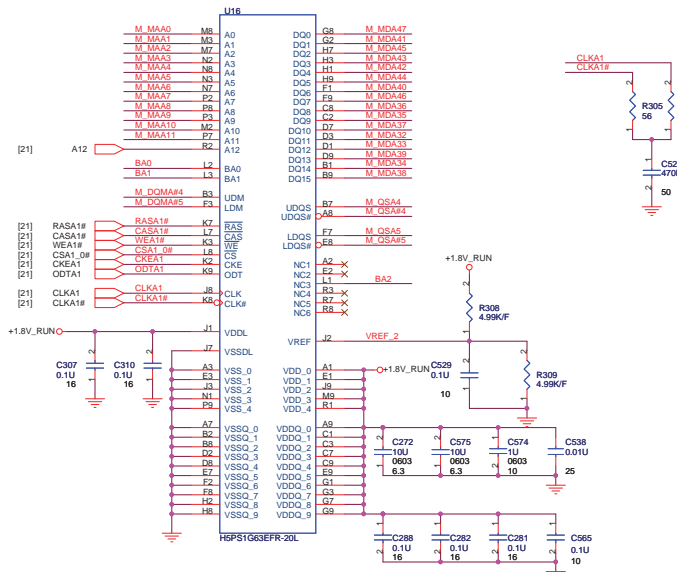

File	MS2-S2_DDR2_512M	
Size	Document Number	Rev
	V46C	1B
Date:	Saturday, June 06, 2009	Sheet 22 of 53

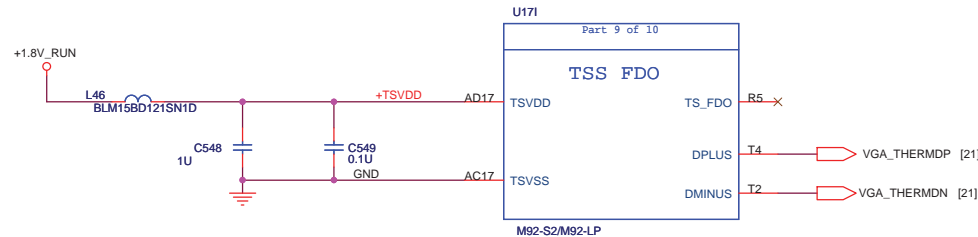
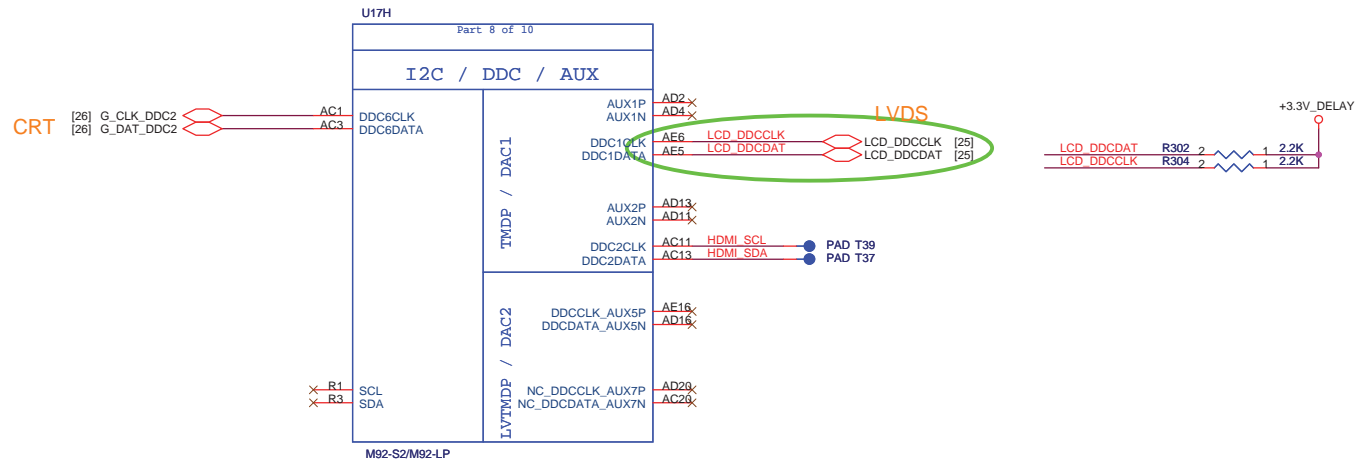
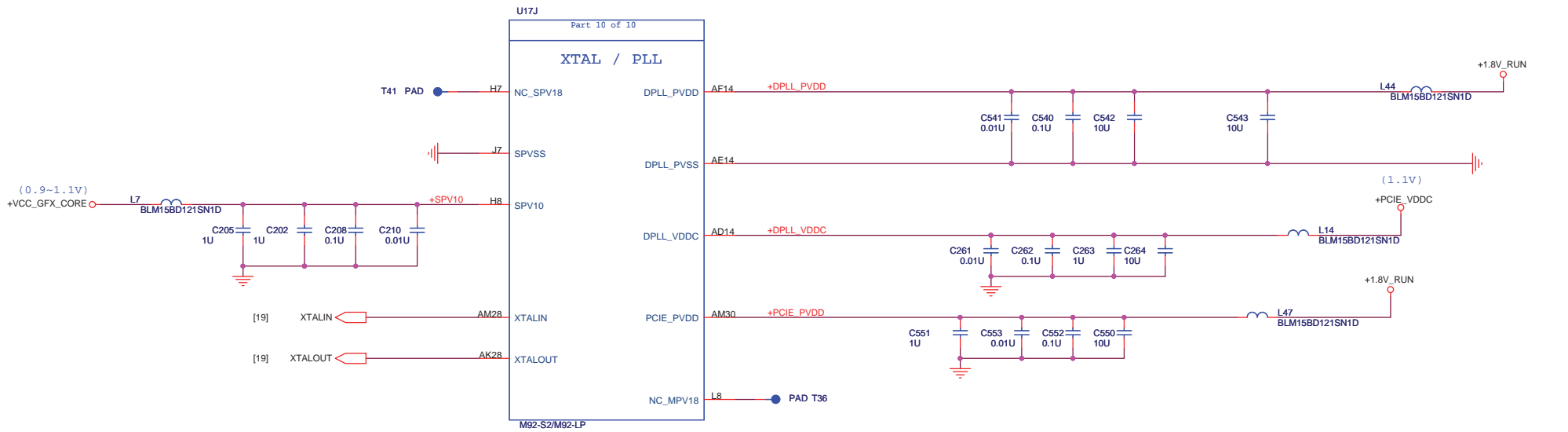

QUANTA COMPUTER

File: M92-S2_XTAL/PLL/I2C

Size	Document Number VM8G	Rev 1B
Date: Tuesday, June 02, 2009	Sheet 23 of 53	

TMDP(HDMI) INTERFACE

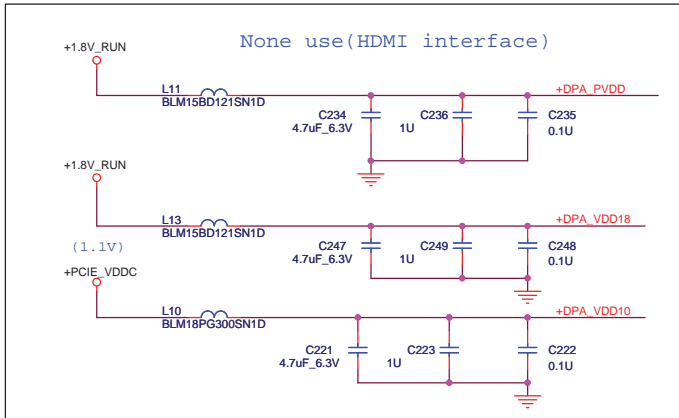
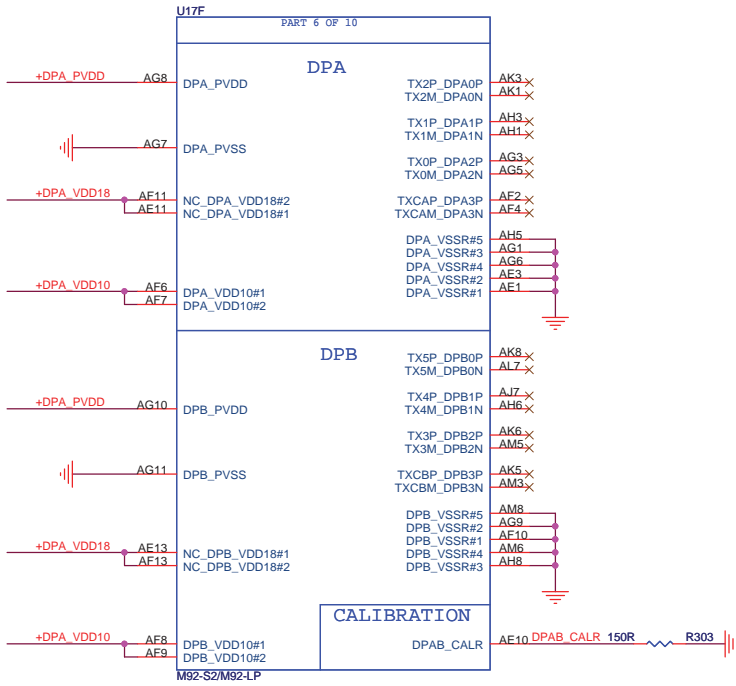

LVDS INTERFACE

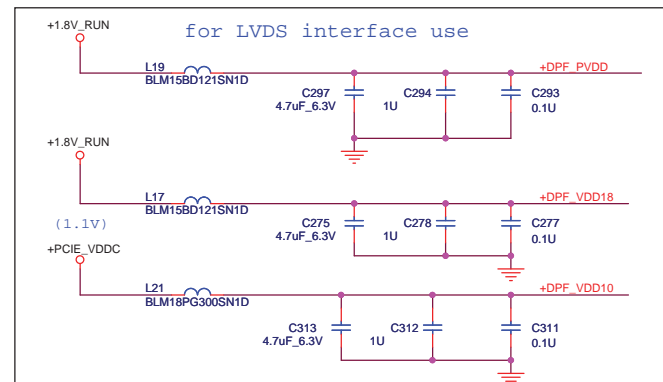
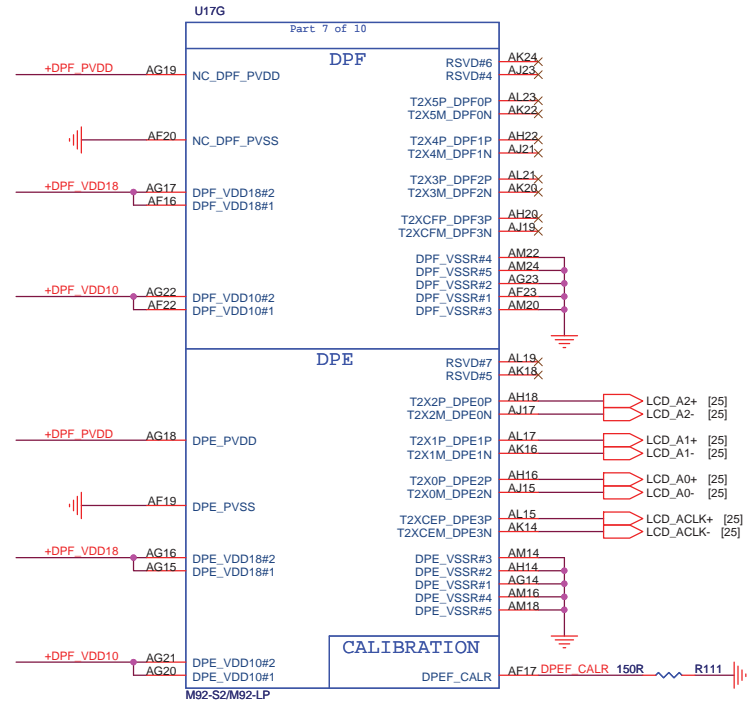

QUANTA COMPUTER

File: M92-S2_TMDDP I/F

Size	Document Number VM8G	Rev 1B
Date:	Tuesday, June 02, 2009	Sheet 24 of 53

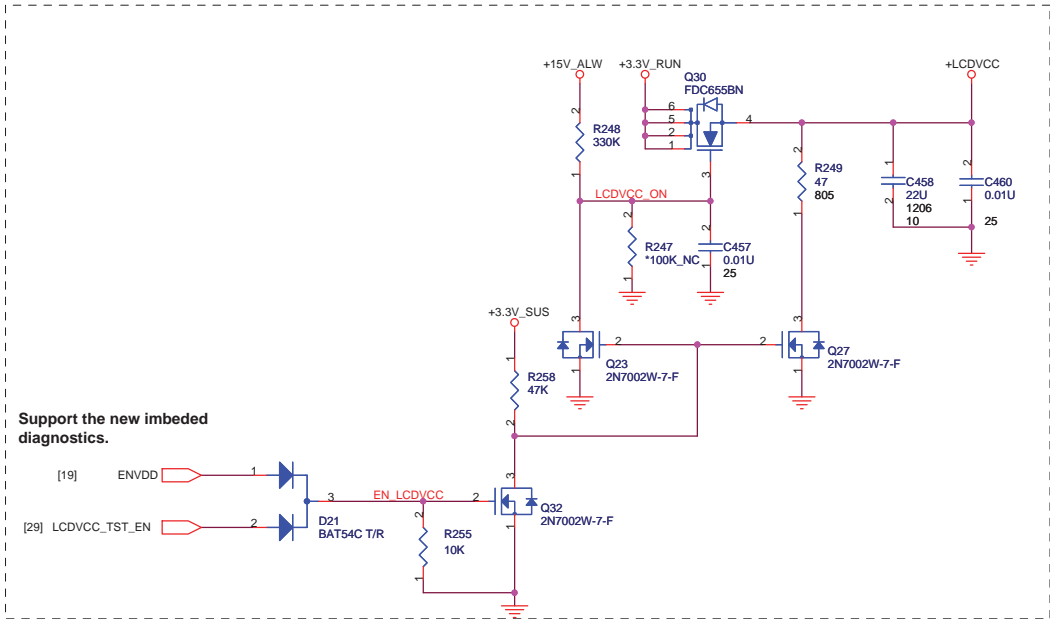

Support the new imbedded diagnostics.

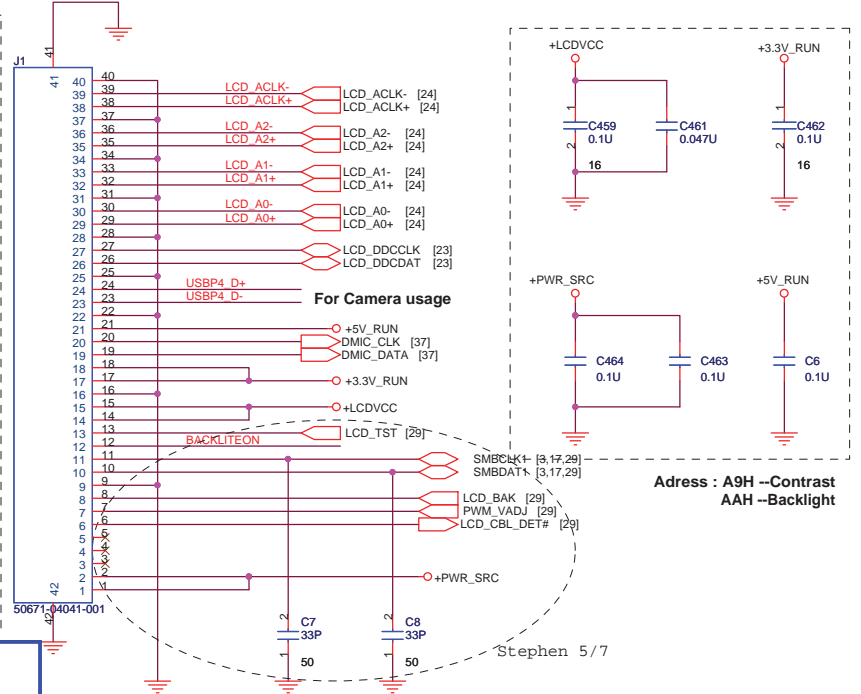
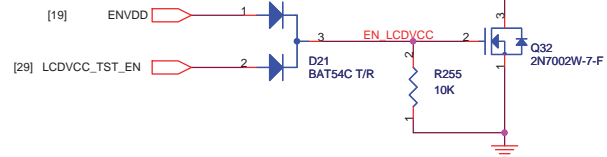

Stephen 5/7

Address : A9H --Contrast
AAH --Backlight

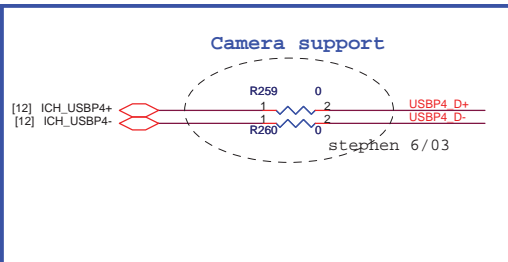

Camera support

stephen 6/03

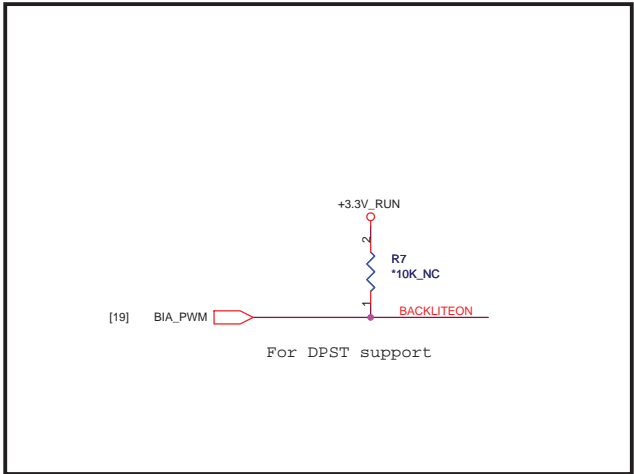
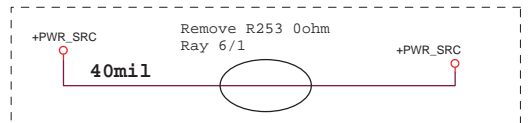

For DPST support

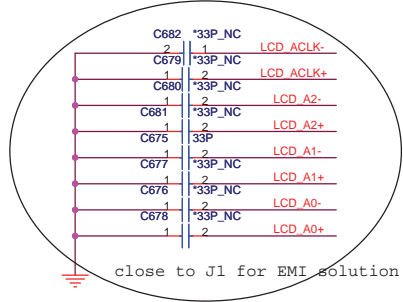

close to J1 for EMI solution

QUANTA COMPUTER

File: LCD CONN & CK-SSCD

Size: Document Number VM8G Rev 1B

Date: Wednesday, June 03, 2009 Sheet 25 of 53

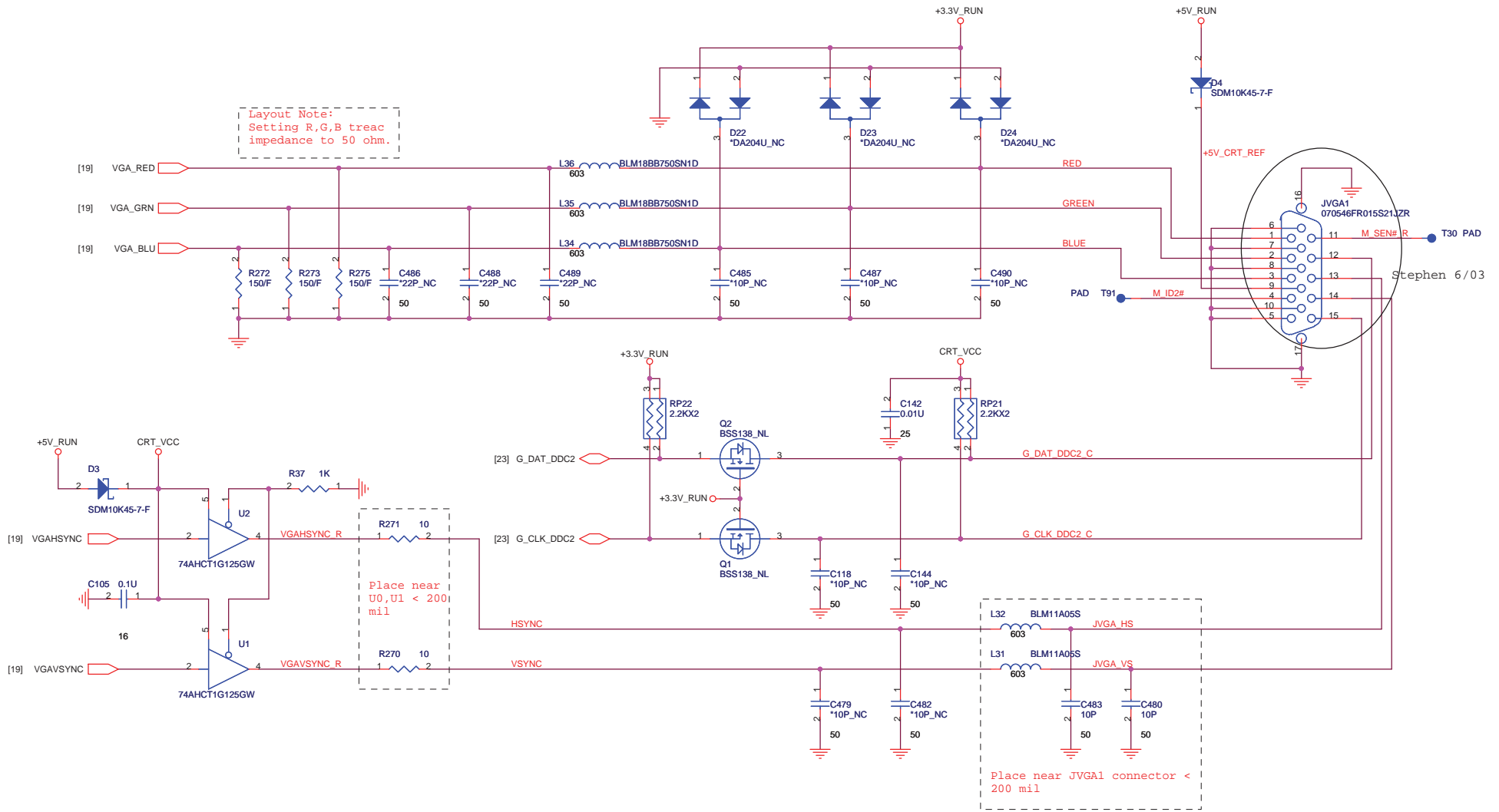

 QUANTA COMPUTER		File	CRT&TV CONN
		Size	Document Number VM8G
Date:	Wednesday, June 03, 2009	Sheet	26 of 53
		Rev	1B

A

B

C

D

E

1

1

2

2

3

3

4

4

 QUANTA COMPUTER		
Title: Card Reader-RTSS158E		
Size:	Document Number: VM8G	Rev: 1B
Date: Tuesday, June 02, 2009 Sheet 27 of 53		

<http://laptop-motherboard-schematic.blogspot.com/>

A

E

+1.5V_CARD Max. 650mA, Average 500mA.
 +3V_CARD Max. 1300mA, Average 1000mA.

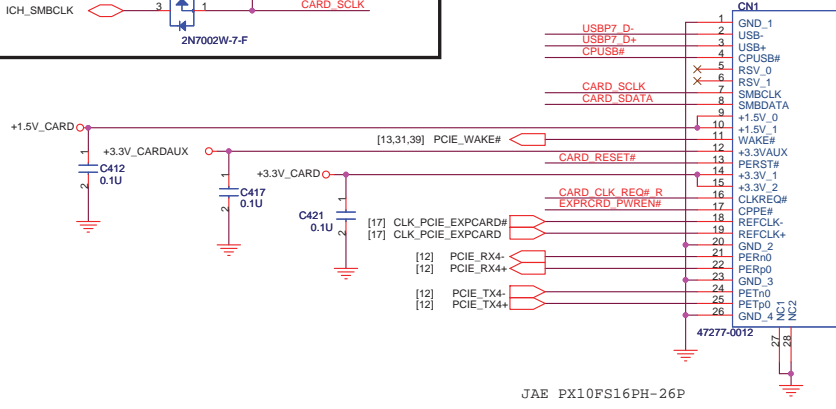
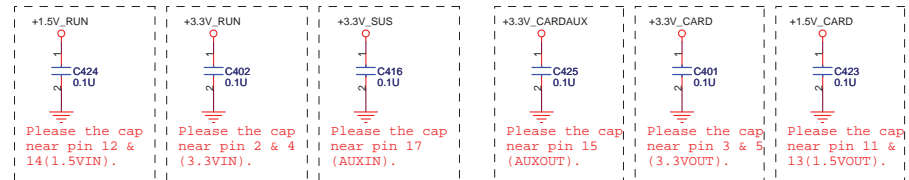
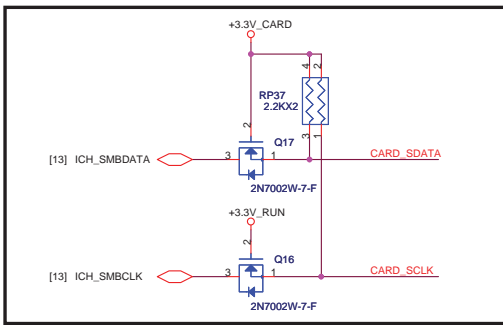
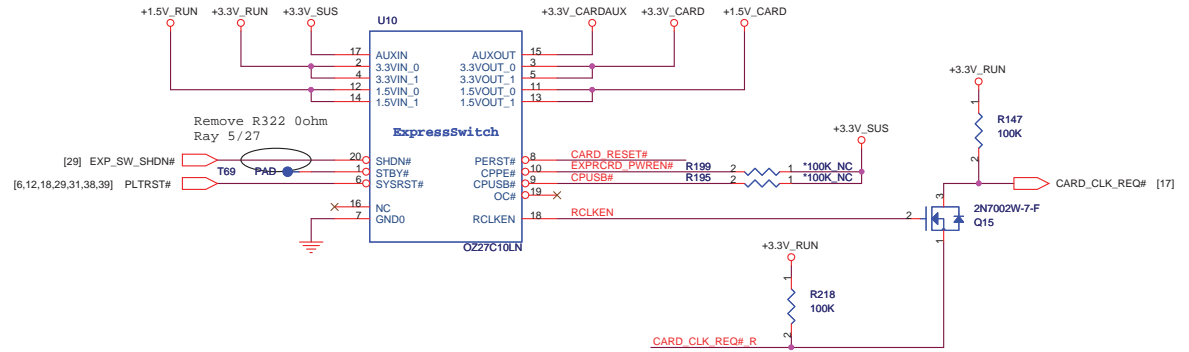
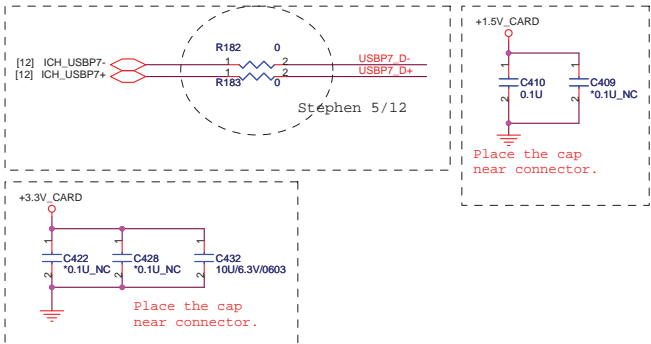

Express Card



*Express Card cage

QUANTA COMPUTER

Title: Express Card

Size: Document Number: Rev 1B

Date: Tuesday, June 02, 2009 Sheet 28 of 53

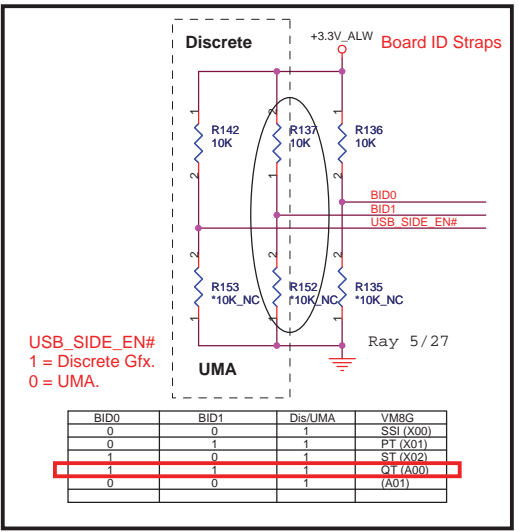
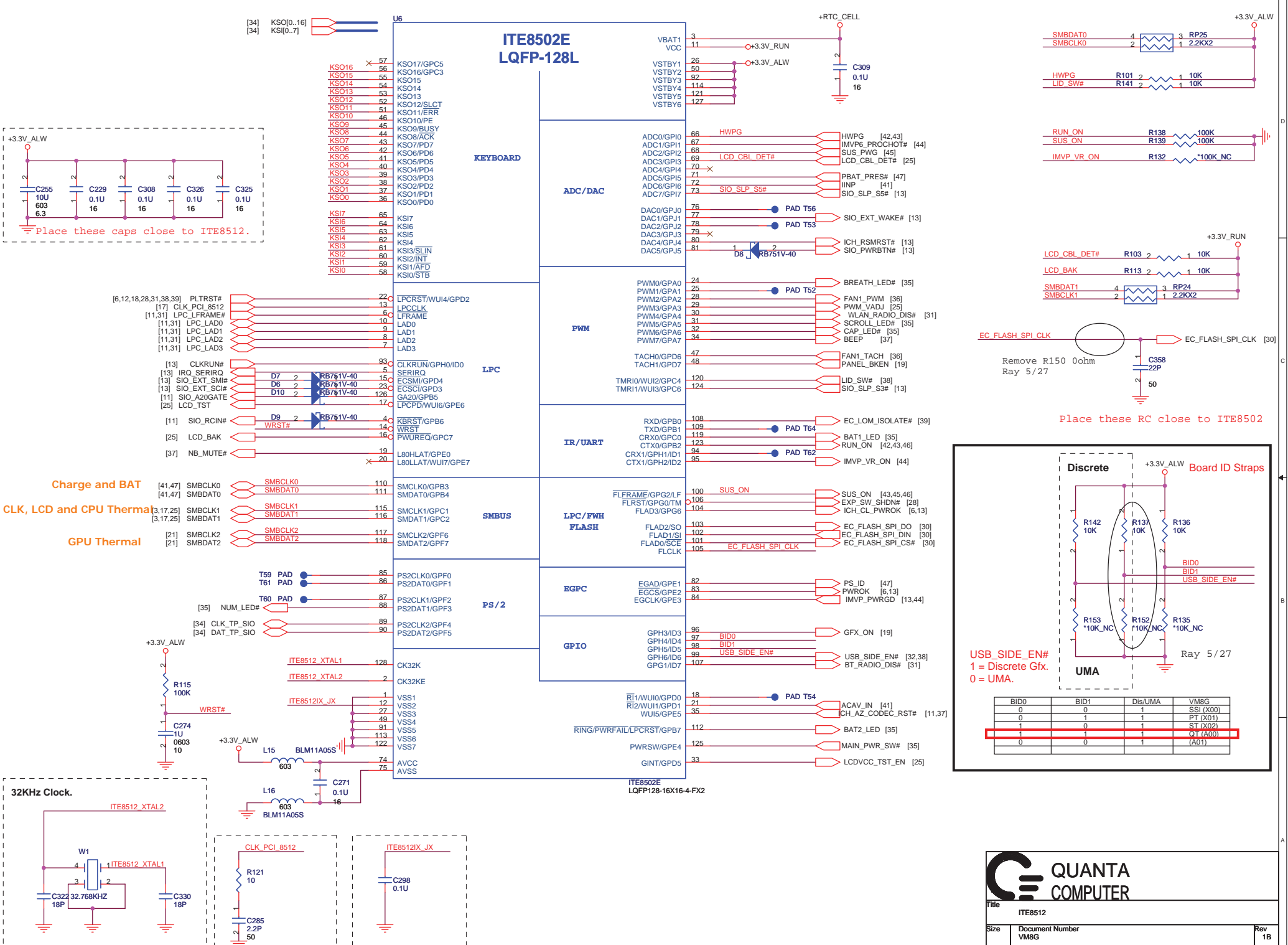

QUANTA COMPUTER

File: ITE8512

Size	Document Number	Rev
	VM8G	1B

Date: Tuesday, June 02, 2009 Sheet 29 of 53

16Mbit (2M Byte), SPI

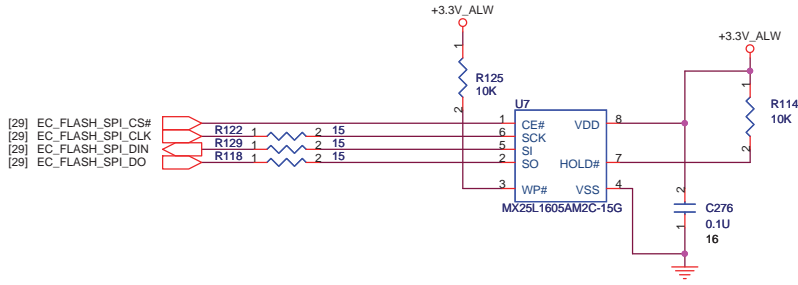

RTC BATTERY

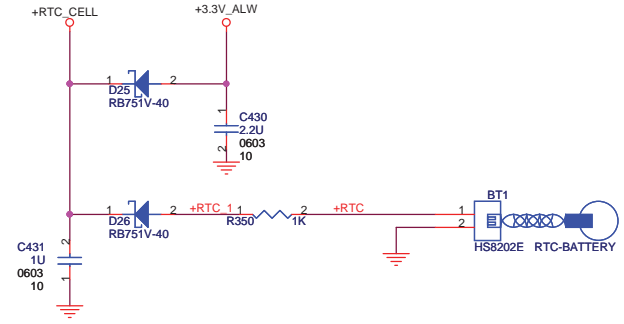

		QUANTA COMPUTER
File: FLASHRTC		
Size: VM8G	Document Number: VM8G	Rev: 1B
Date: Tuesday, June 02, 2009	Sheet: 30	of 53

MiniCard WLAN connector

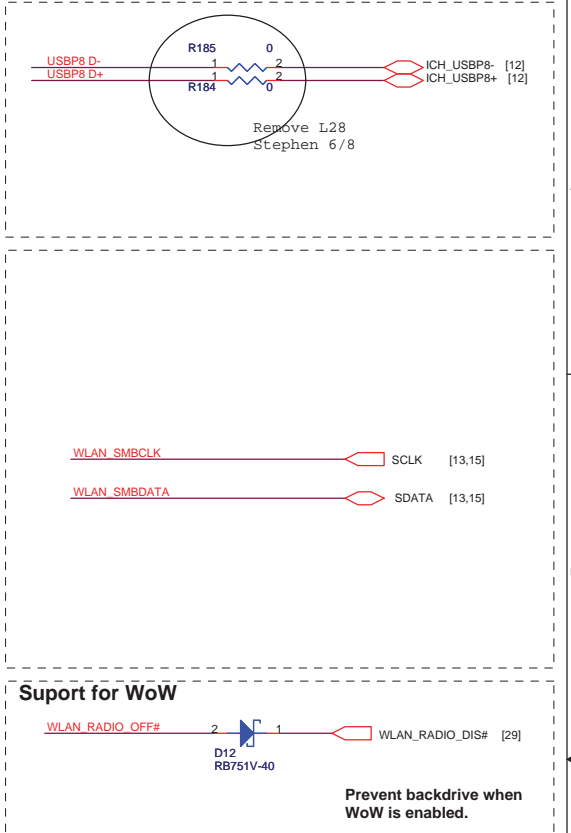
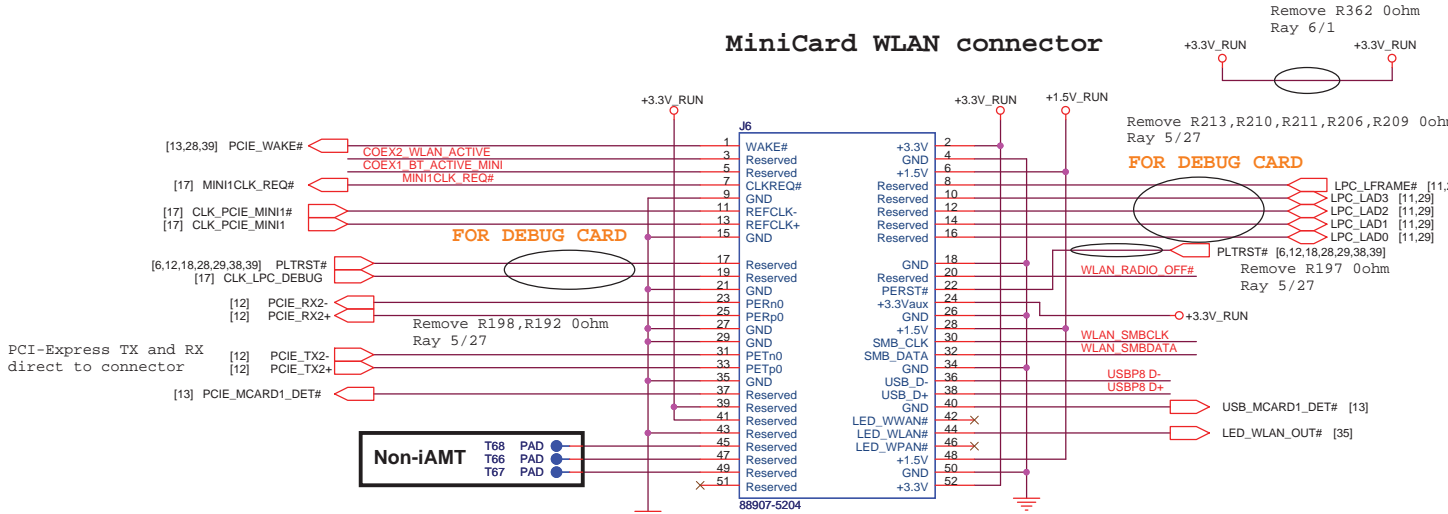

Bluetooth

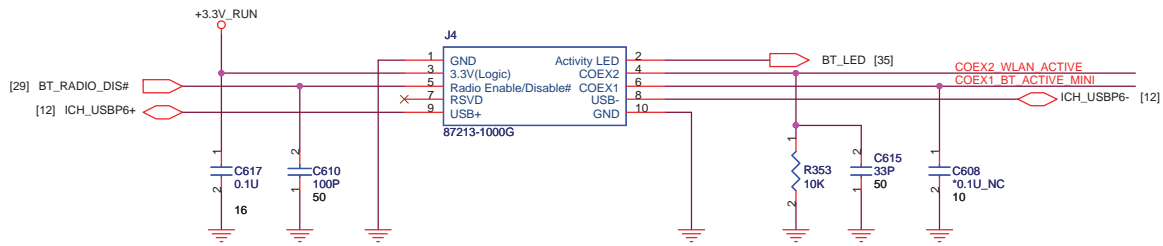

QUANTA COMPUTER

File	MINI Card (WLAN)/BT		
Size	Document Number VM8G	Rev 1B	
Date:	Monday, June 08, 2009	Sheet	31 of 53

External USB PORT hookup reference. Your design may need more or less external ports and may be mapped differently

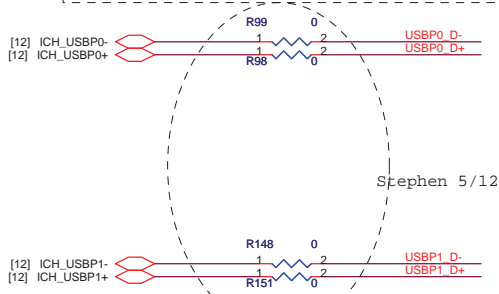

Platforms should put in PADS for the USB chokes if they have the room. Chokes should be NOPOP.

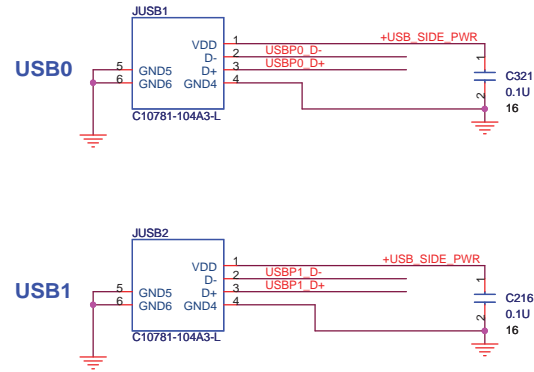
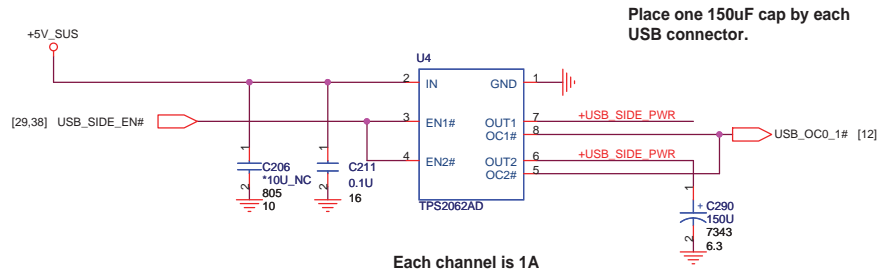

Place ESD diodes as close as USB connector.

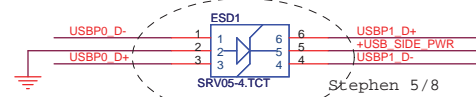

		QUANTA COMPUTER
File	USB	
Size	Document Number VM8G	Rev 1B
Date:	Tuesday, June 02, 2009	Sheet 32 of 53

SATA HDD Connector.

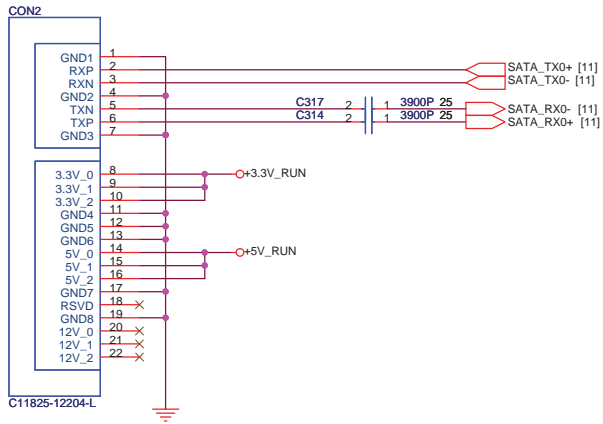

SATA ODD Connector.

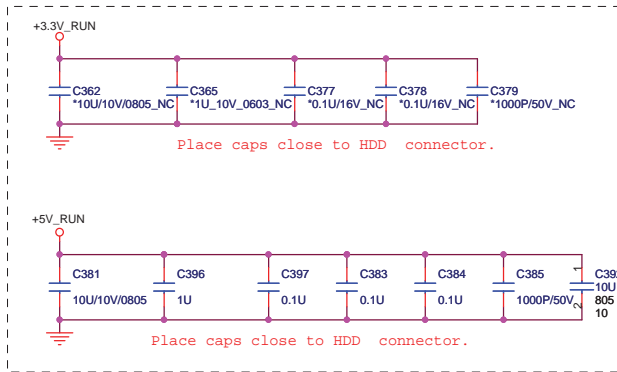
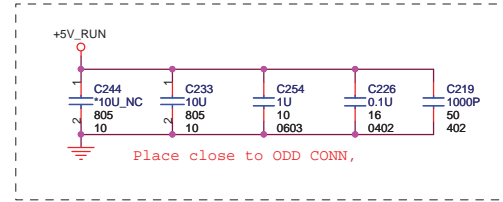
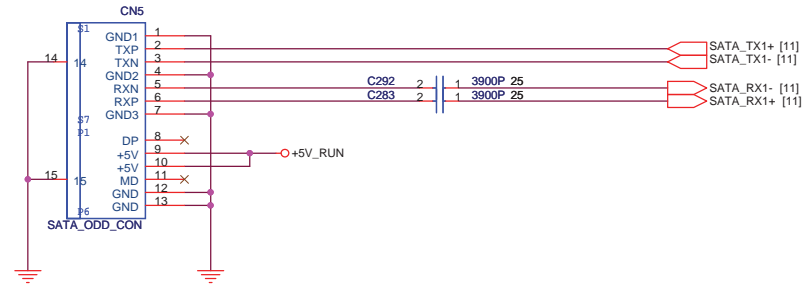

Touch Pad

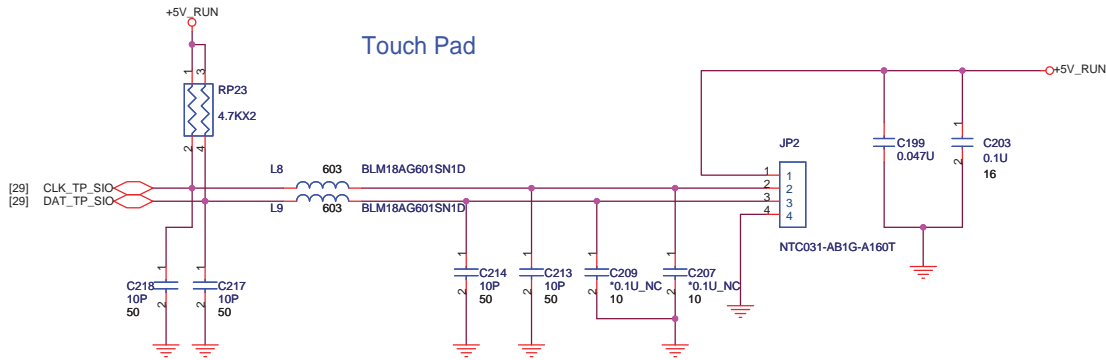

KEYBOARD CONNECTOR

- [29] KSO[0..16]
- [29] KSI[0..7]

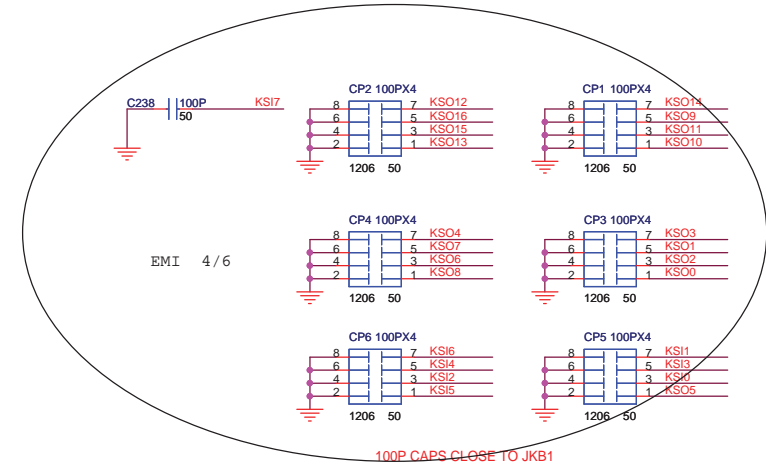
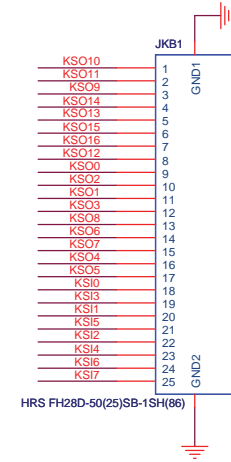

**QUANTA
COMPUTER**

File: TOUCH PAD, BULE TOOTH & FIR

Size	Document Number VM8G	Rev 1B
Date:	Tuesday, June 02, 2009	Sheet 34 of 53

Keyboard LED

Dash board connector



Power Switch

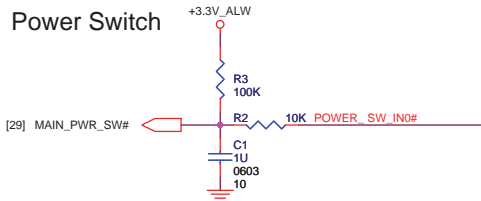

HDD activity LED.

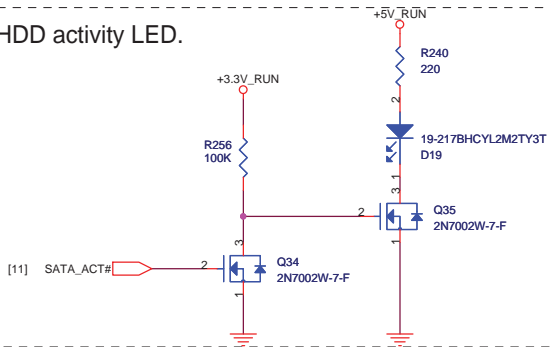

Bluetooth activity LED.

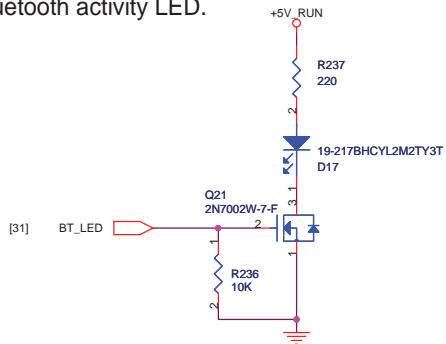

Power & Suspend.

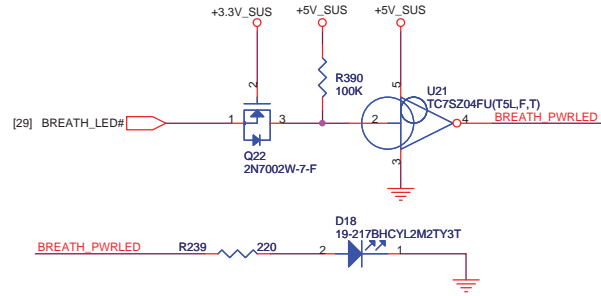

WLAN

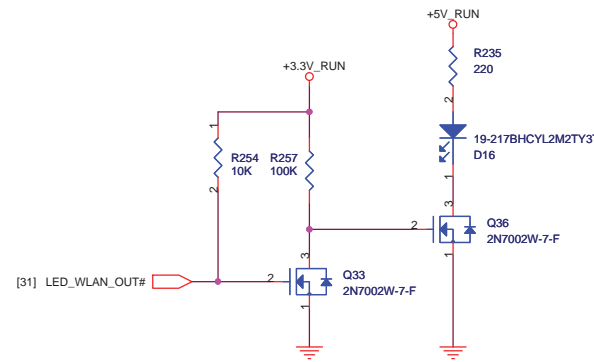

Battery status.

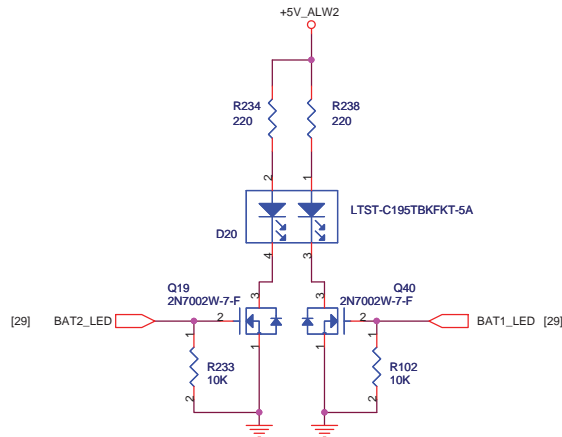

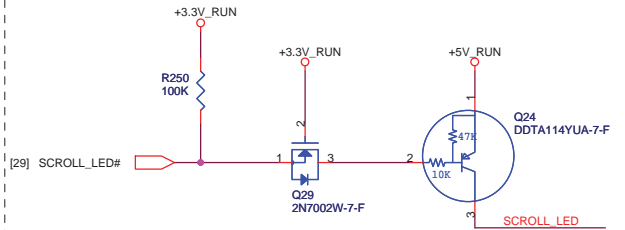
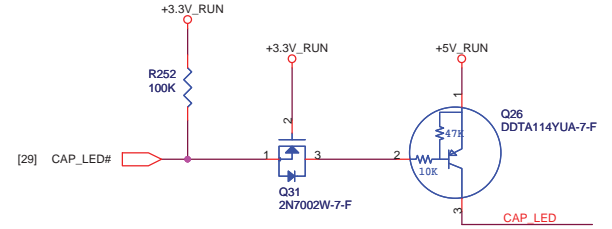
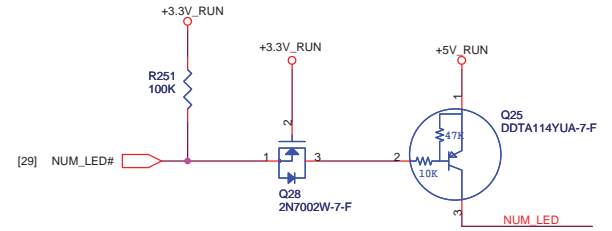

Keyboard LED

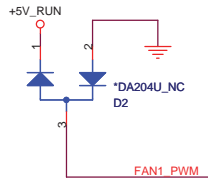
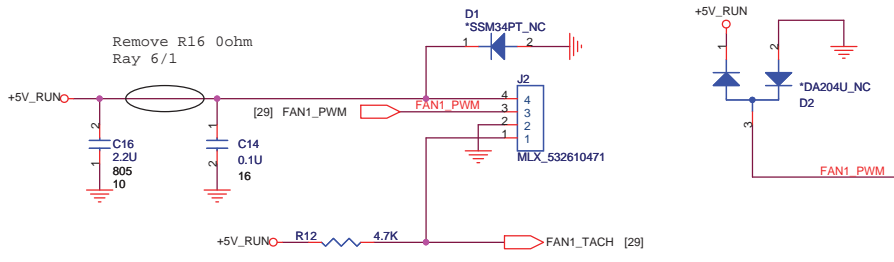

File SWITCH, KEYBOARD & LED

Size	Document Number VM8G	Rev 1B
Date:	Tuesday, June 02, 2009	Sheet 35 of 53



 QUANTA COMPUTER		
File FAN & THERMAL		
Size	Document Number VM8G	Rev 1B
Date: Tuesday, June 02, 2009	Sheet 36 of 53	

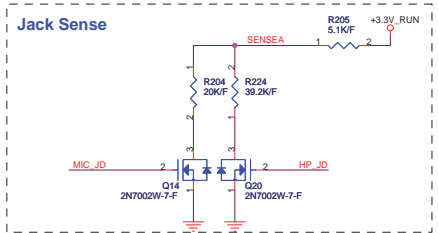
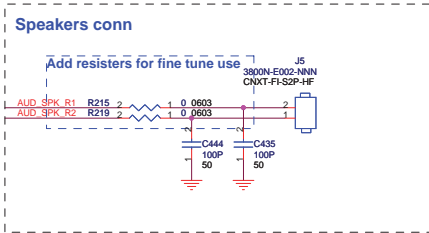
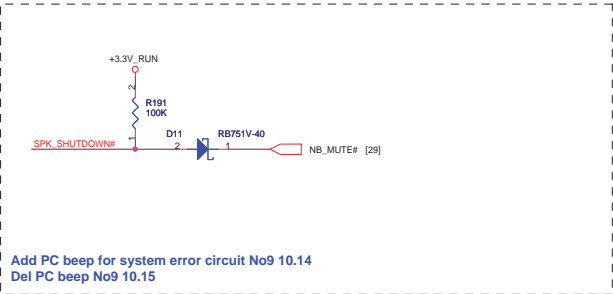
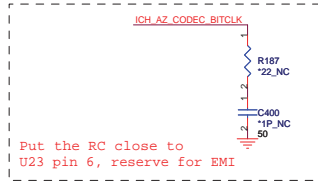

AUDIO CODEC

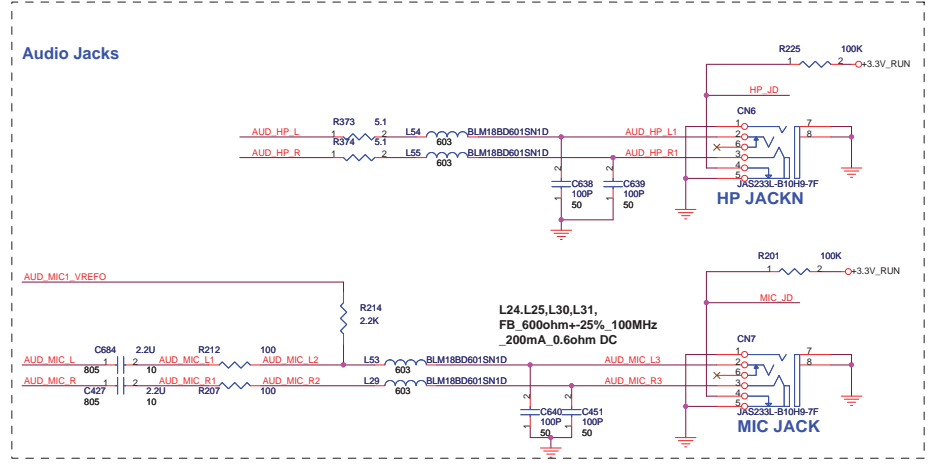
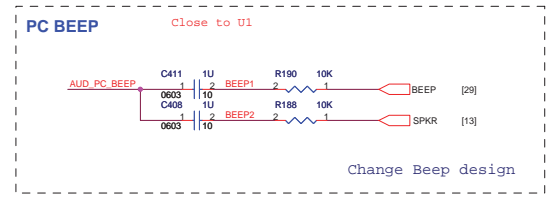
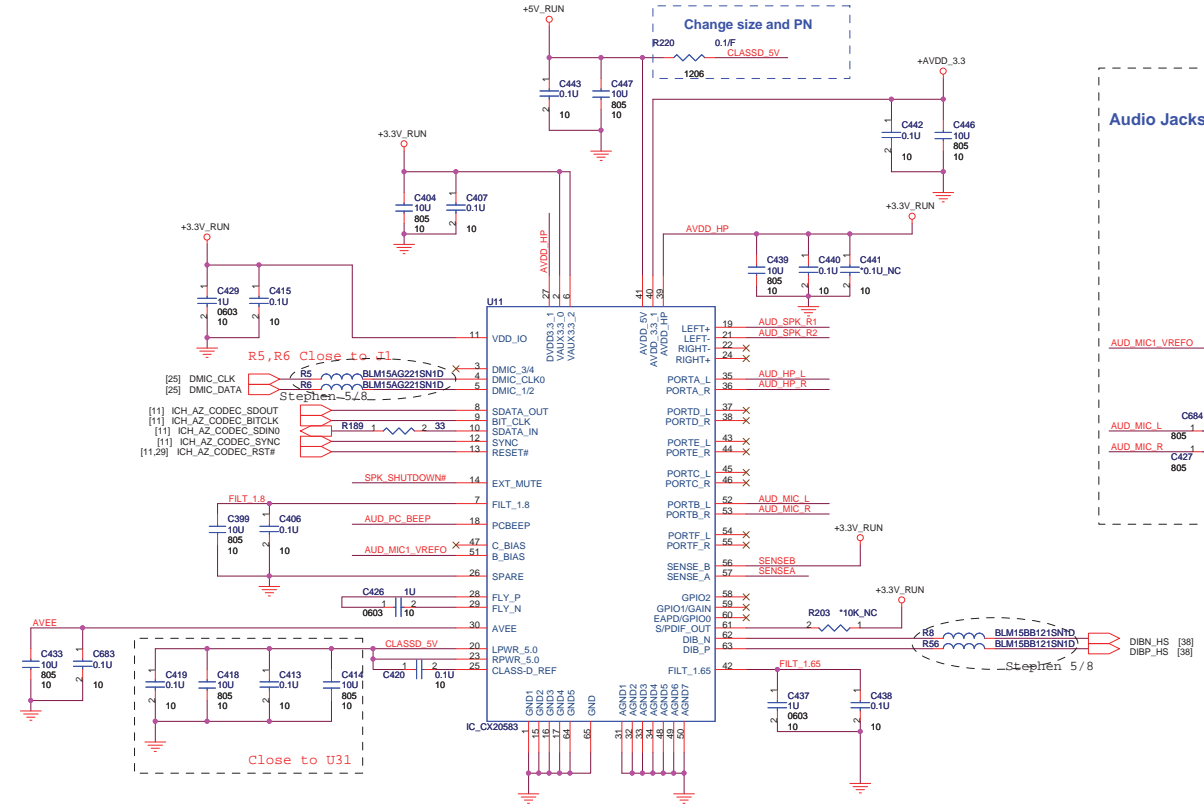

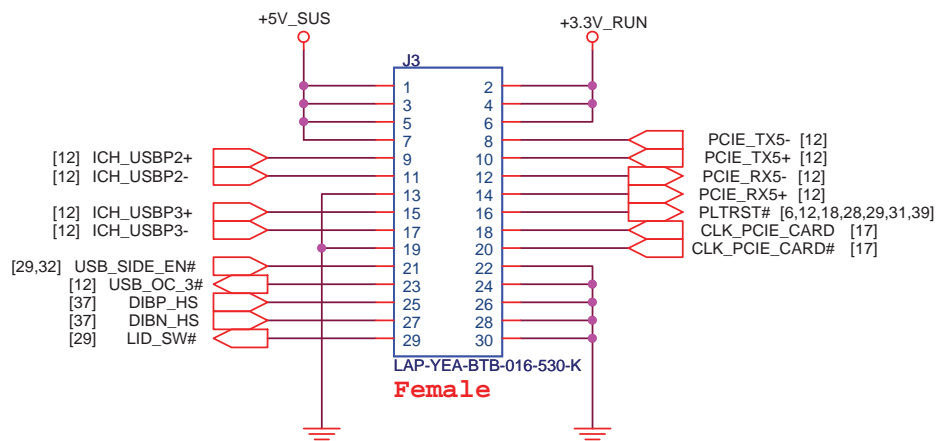
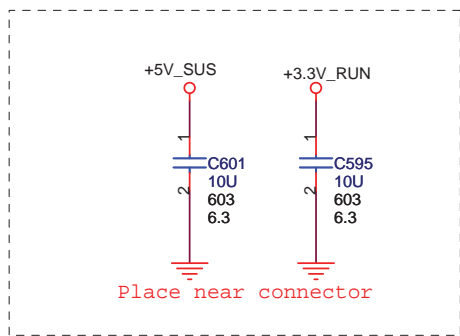

Board to board connector (Modem Card + Cardreader+1394a+ 2 USB Port)



Title		
Size	Document Number	Rev
	VM8G	1B
Date:	Tuesday, June 02, 2009	Sheet 38 of 53

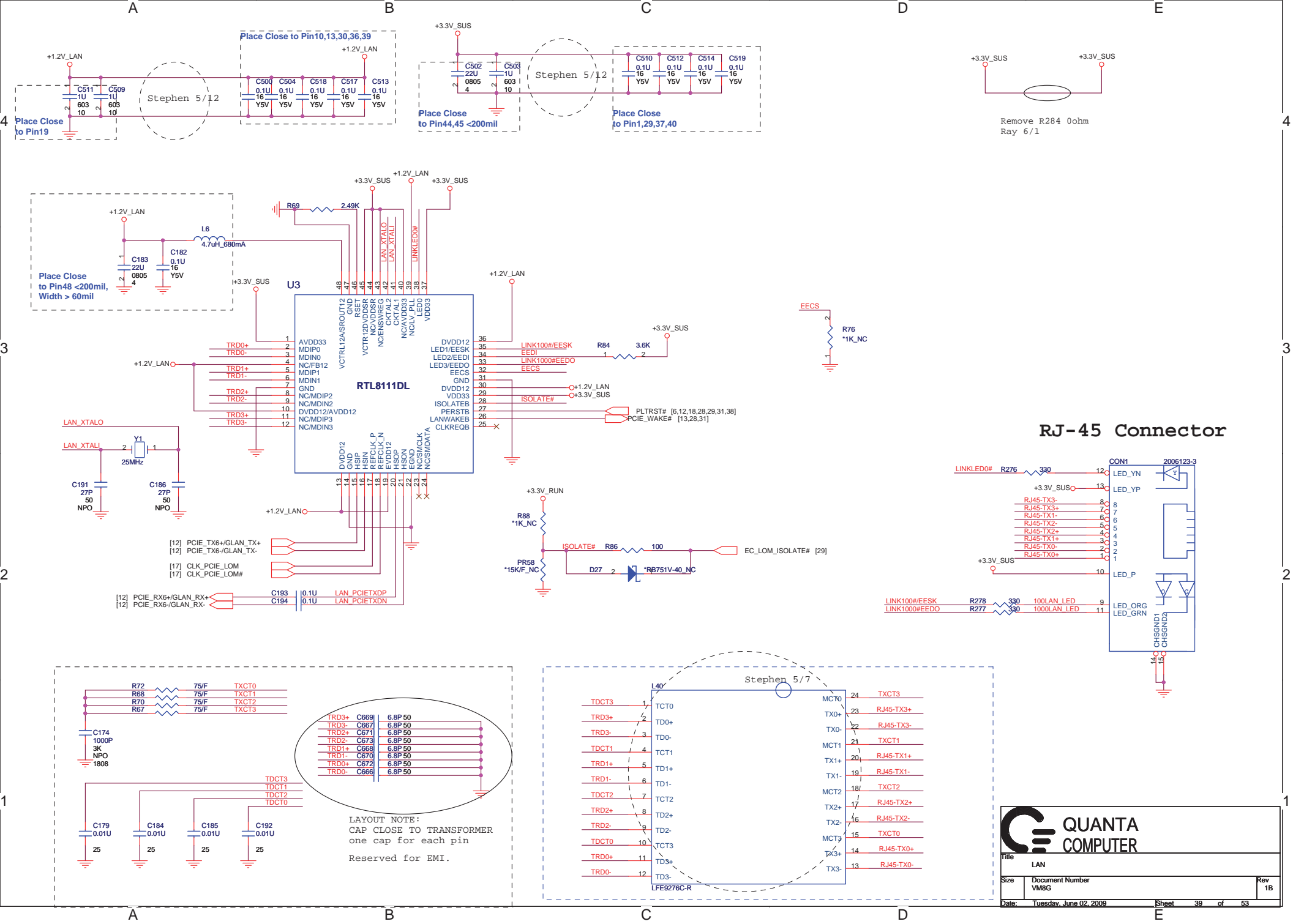

QUANTA COMPUTER

Title: LAN

Size	Document Number	Rev
VM8G		1B

Date: Tuesday, June 02, 2009 Sheet 39 of 53



		QUANTA COMPUTER
Title		System Reset Circuit
Size	Document Number	Rev
	VM8G	1B
Date:	Tuesday, June 02, 2009	Sheet 40 of 53

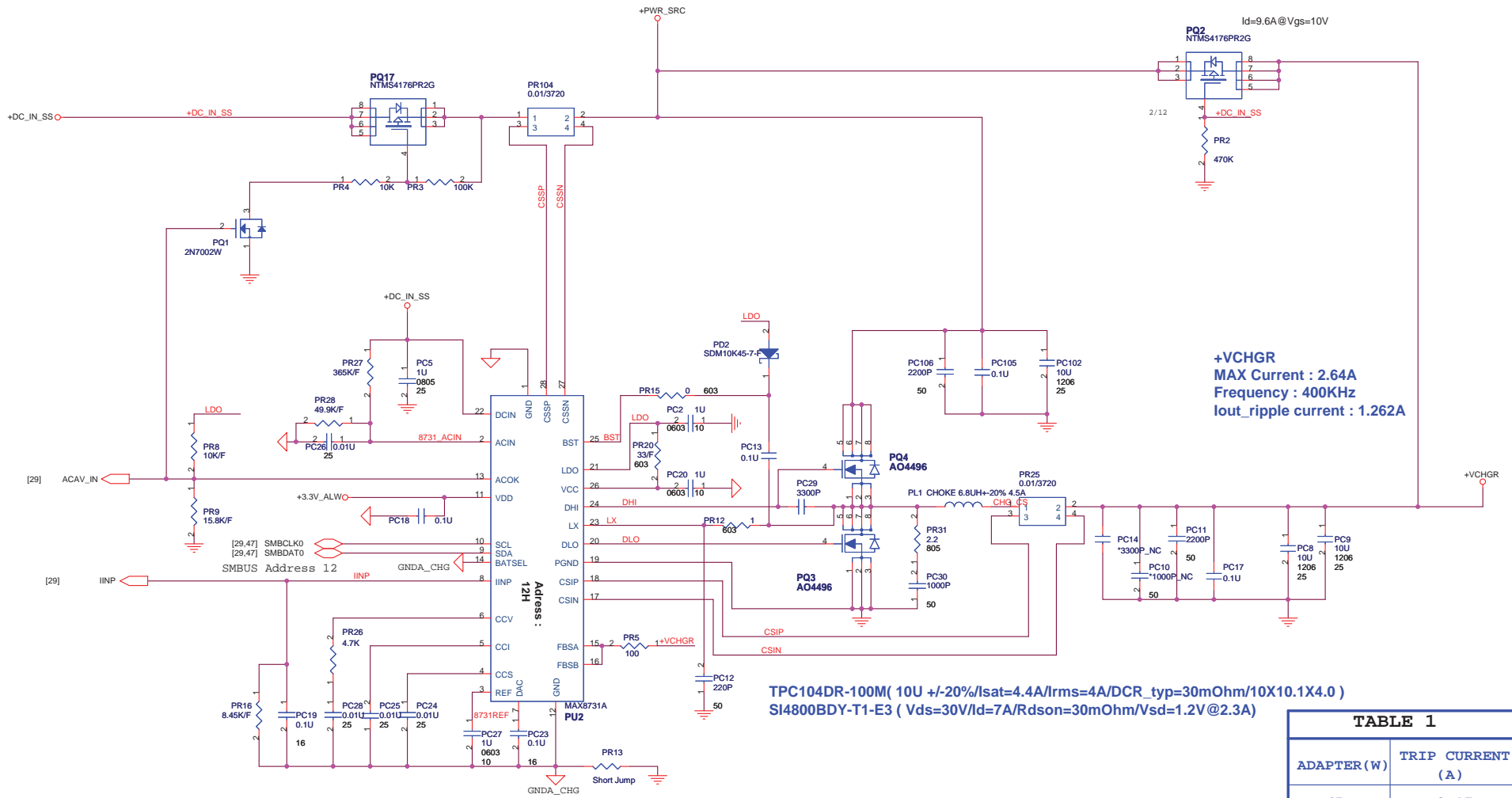

+VCHGR
MAX Current : 2.64A
Frequency : 400KHz
Iout_ripple current : 1.262A

TPC104DR-100M (10U +/-20%/Isat=4.4A/rms=4A/DCR_typ=30mOhm/10X10.1X4.0)
SI4800BDY-T1-E3 (Vds=30V/Id=7A/Rdson=30mOhm/Vsd=1.2V@2.3A)

TABLE 1

ADAPTER (W)	TRIP CURRENT (A)
65	3.17
90	4.43
130	6.43
150	7.43
200	9.75
230	11.28

QUANTA COMPUTER

File: Charger (MAX8731A)

Size: VM6G	Document Number: VM6G	Rev: 1B
------------	-----------------------	---------

Date: Tuesday, June 02, 2009 Sheet 41 of 53

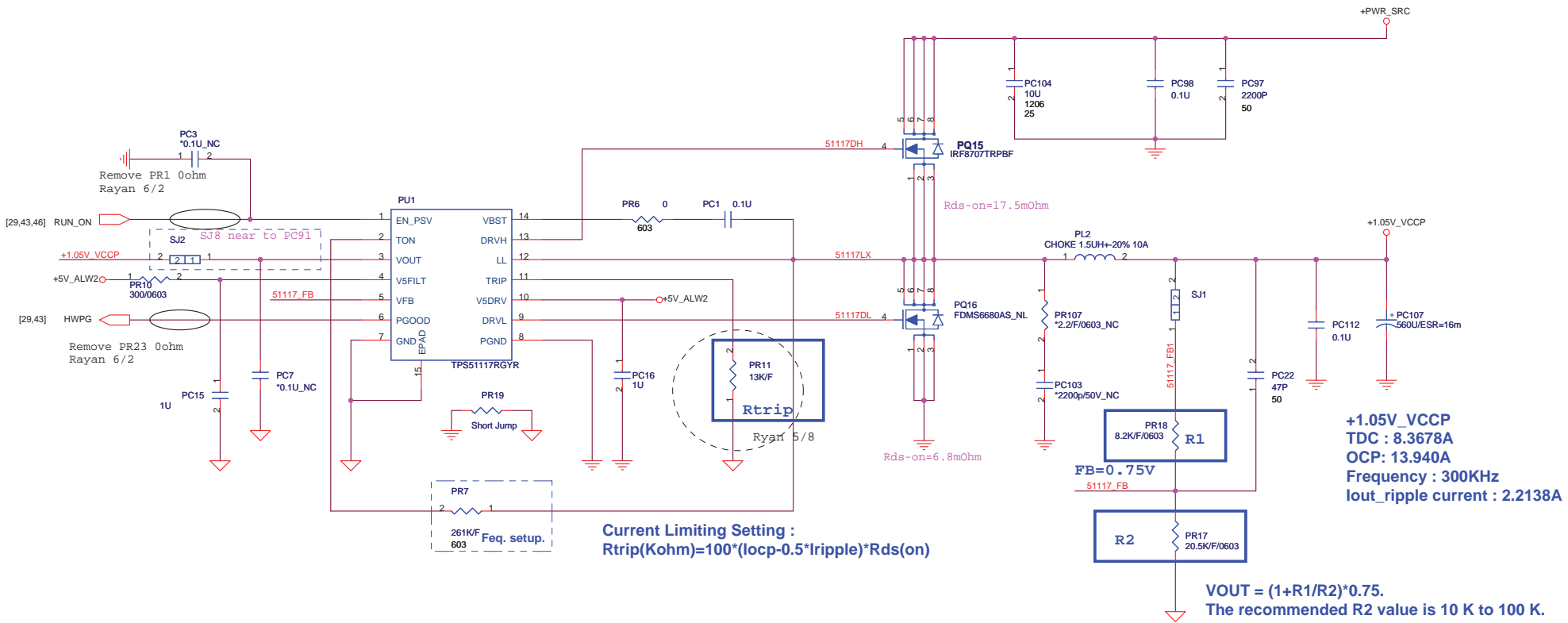

APXE2R5ARA561MF61G (560UF/2.5V/ESR16)
 SIL104R-1R5B (1.5U +/- 30%/ Isat=10A/DCR_max=8.1m Ohm/10X10X3.8)
 IRF8707TRPBF (Vds=30V/Id=9.1A @75deg/Rdson=17.5mOhm)
 IRF8714TRPBF (Vds=30V/ ID=11A @70deg/Rdson=13mOhm/Vsd=1.0V @11A)

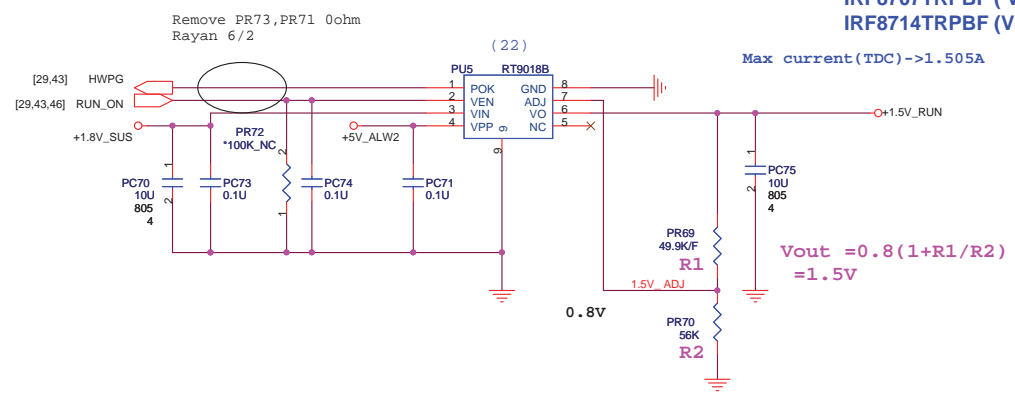

QUANTA COMPUTER
 File: 1.05_VCCP & 1.5V_RUN
 Size: Document Number VM8G Rev 1B
 Date: Saturday, June 06, 2009 Sheet 42 of 53

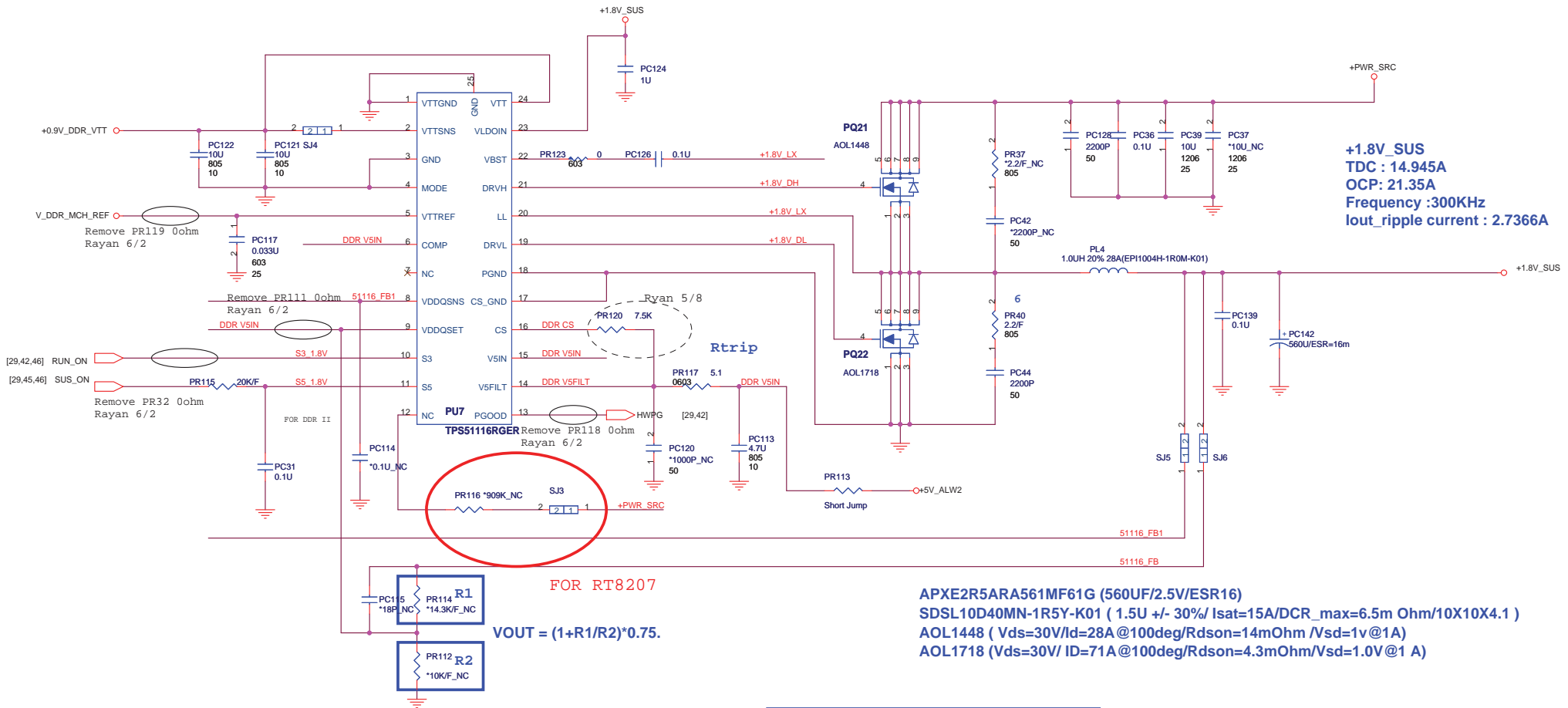

+1.8V_SUS
 TDC : 14.945A
 OCP: 21.35A
 Frequency :300KHz
 Iout_ripple current : 2.7366A

FOR RT8207
 $V_{OUT} = (1+R1/R2)*0.75.$

APXE2R5ARA561MF61G (560UF/2.5V/ESR16)
 SDSL10D40MN-1R5Y-K01 (1.5U +/- 30%/ Isat=15A/DCR_max=6.5m Ohm/10X10X4.1)
 AOL1448 (Vds=30V/Id=28A @100deg/Rdson=14mOhm /Vsd=1v@1A)
 AOL1718 (Vds=30V/ ID=71A @100deg/Rdson=4.3mOhm/Vsd=1.0V@1 A)

Current Limiting Setting :
 $R_{trip}(Kohm)=100*(I_{ocp}-0.5*I_{ripple})*R_{ds(on)}$

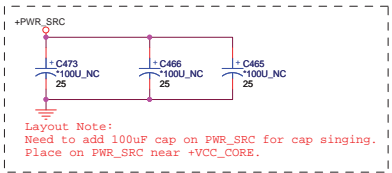

+VCC_CORE
TDC : 35A
MAX:47A
Frequency : 300KHz
Iout_ripple current : 9.64A of each phase.

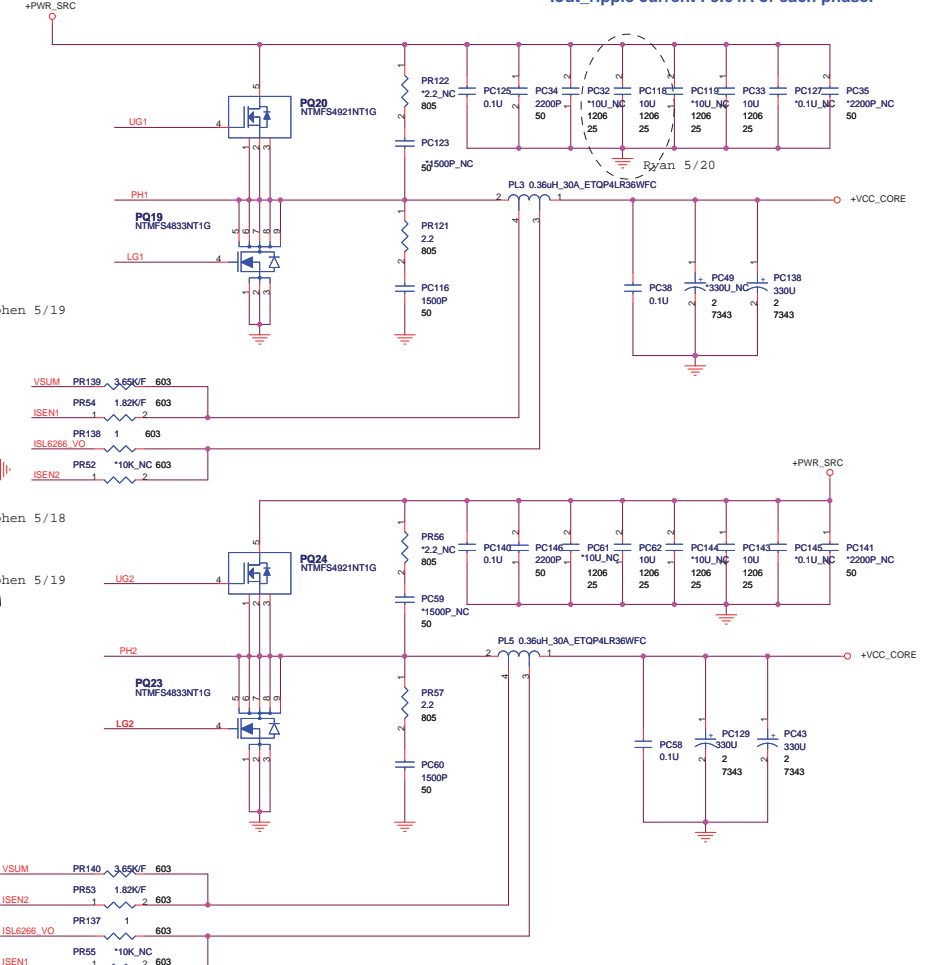
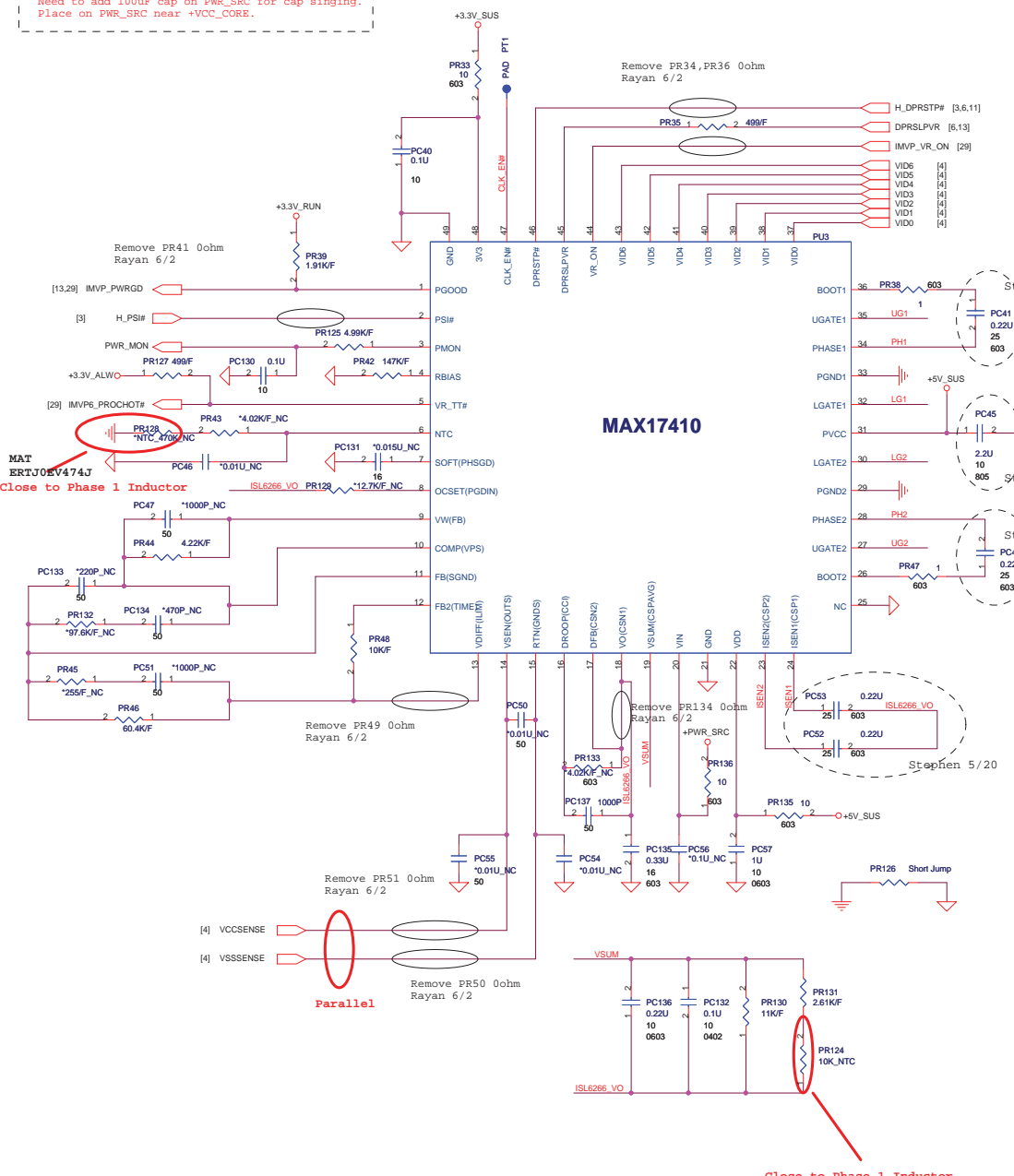

D6	D5	D4	D3	D2	D1	D0	Output
0	0	0	0	0	0	0	1.500V
0	0	0	0	0	0	1	1.4875
0	0	0	0	0	1	1	1.4375
0	0	0	0	1	1	1	1.4125
0	0	0	1	0	1	1	1.4000
0	0	1	0	0	1	1	1.2875
0	0	1	1	0	0	1	1.2000
0	0	1	1	0	1	0	1.1500
0	1	0	1	0	0	0	1.0000
0	1	0	1	0	1	1	0.9625
0	1	1	1	1	0	0	0.7500
1	0	0	1	0	0	0	0.6500
1	0	1	0	0	0	0	0.5000
1	1	0	0	0	0	0	0.3000

ETQP4LR36WFC (0.36U +/- 20%/ Isat=24A/DCR_max=1.1m Ohm/11.5X10X4)
 NTMFS4921NT1G (Vds=30V/Id=10.2A @85deg/Rdsn=10.5mOhm)
 NTMFS4946NT1G (Vds=30V/ ID=14.6A @85deg/Rdsn=5.1mOhm/Vsd=1.0V @30A)
 EEFSXD0331YR (330UF/2V/ESR9)

QUANTA COMPUTER

Title: CPU_Core_2Phase (MAX17410)

Size: Document Number VM8G

Date: Saturday, June 06, 2009

Sheet: 44 of 53

Rev: 1B

DC/DC +3V_ALW/+5V_SUS/+5V_ALW /+15V_ALW

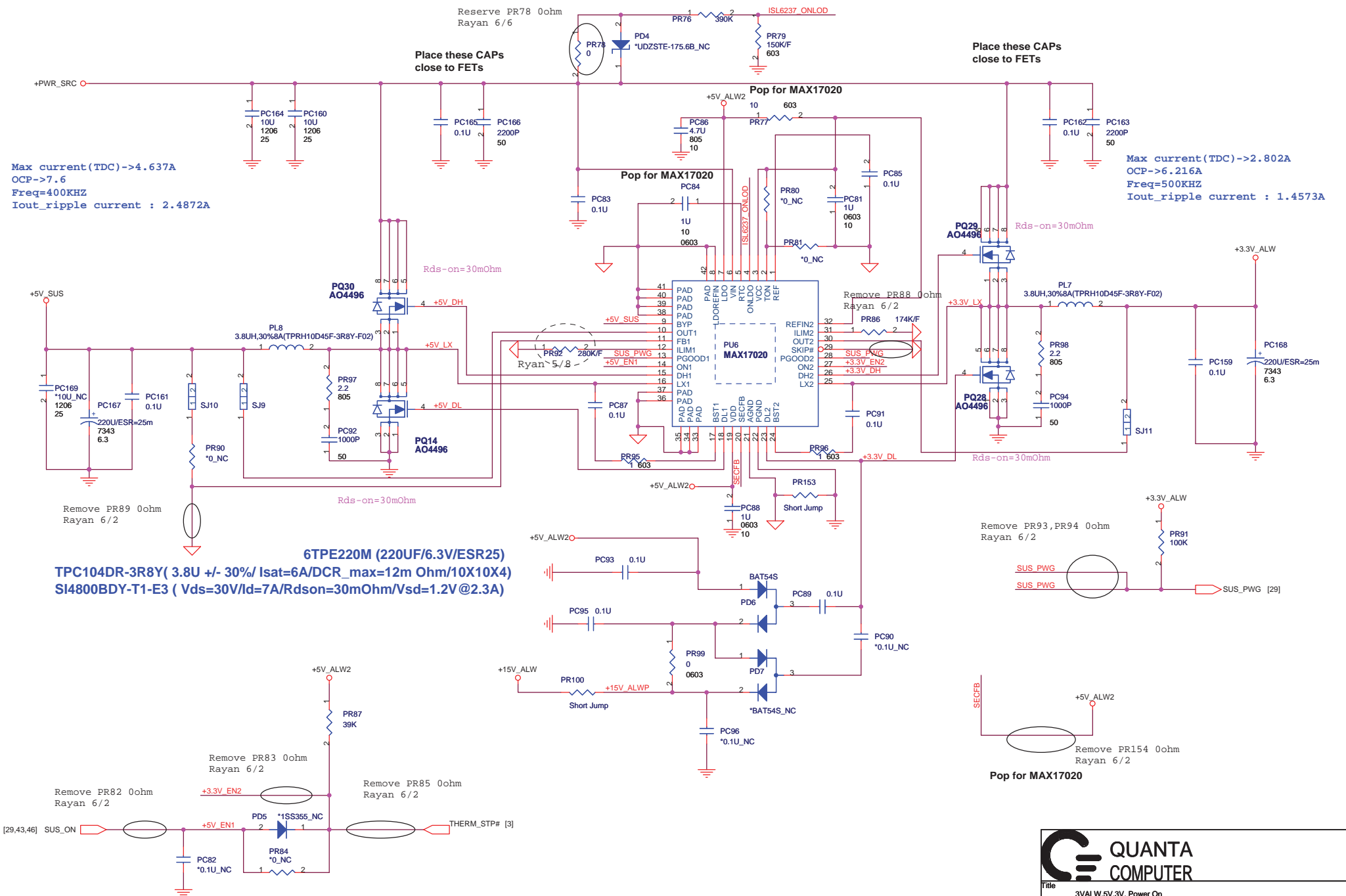

Max current(TDC)->4.637A
 OCP->7.6
 Freq=400KHZ
 Iout_ripple current : 2.4872A

Max current(TDC)->2.802A
 OCP->6.216A
 Freq=500KHZ
 Iout_ripple current : 1.4573A

6TPE220M (220UF/6.3V/ESR25)
TPC104DR-3R8Y (3.8U +/- 30%/ Isat=6A/DCR_max=12m Ohm/10X10X4)
SI4800BDY-T1-E3 (Vds=30V/Id=7A/Rdson=30mOhm/Vsd=1.2V @2.3A)

Size VM8G	Document Number VM8G	Rev 1B
Date: Saturday, June 06, 2009	Sheet 45 of 53	

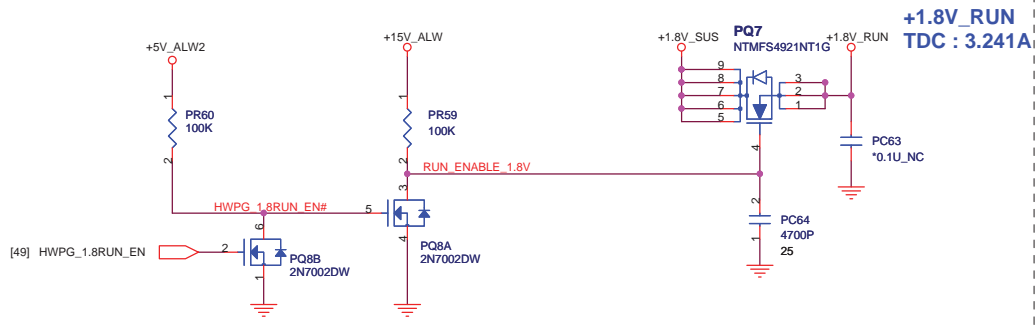
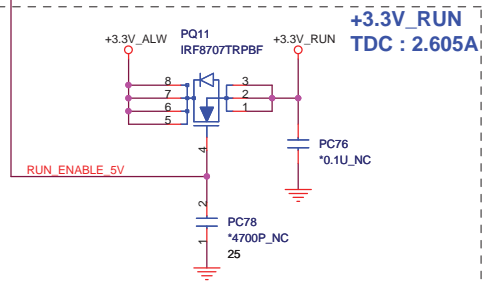
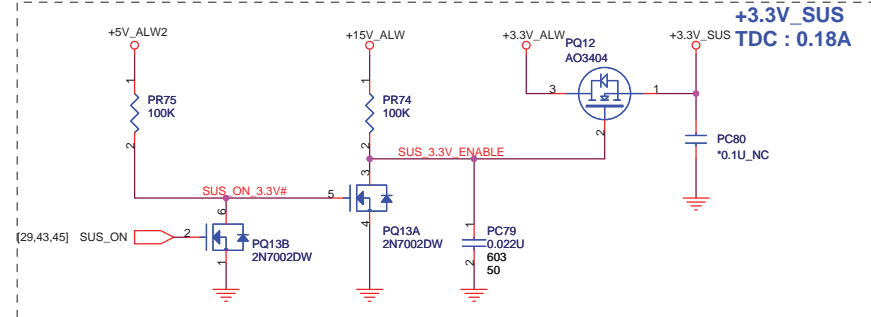
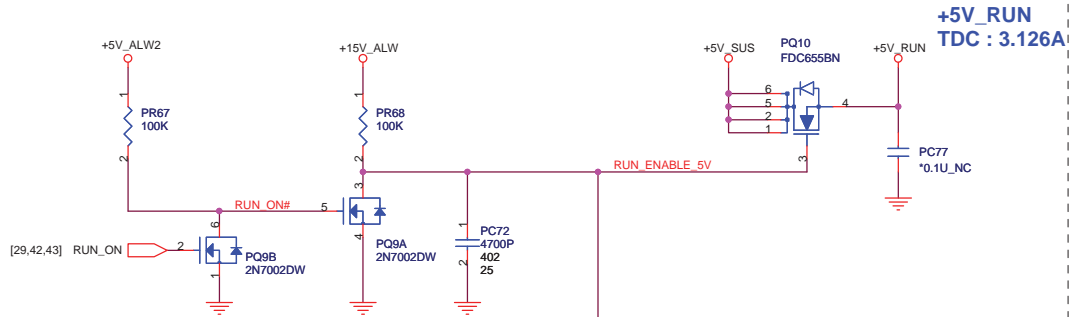

Reserve discharge path

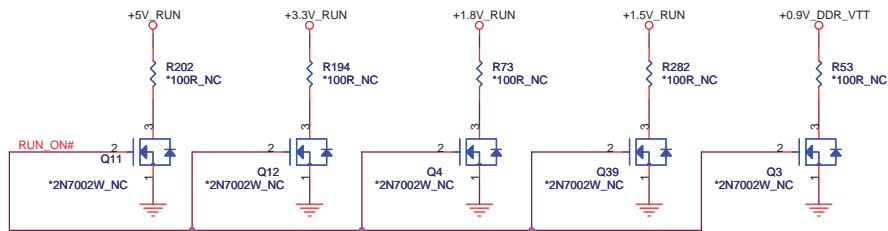

Reserve discharge path

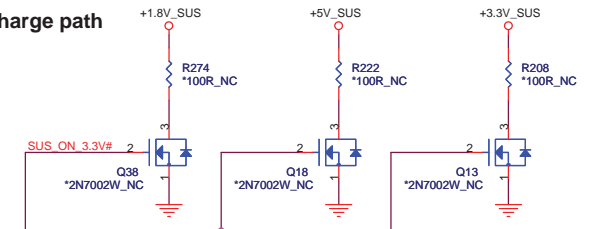

QUANTA COMPUTER

File: RUN POWER SW

Size	Document Number	Rev
	VM8G	1B
Date:	Tuesday, June 02, 2009	Sheet 46 of 53

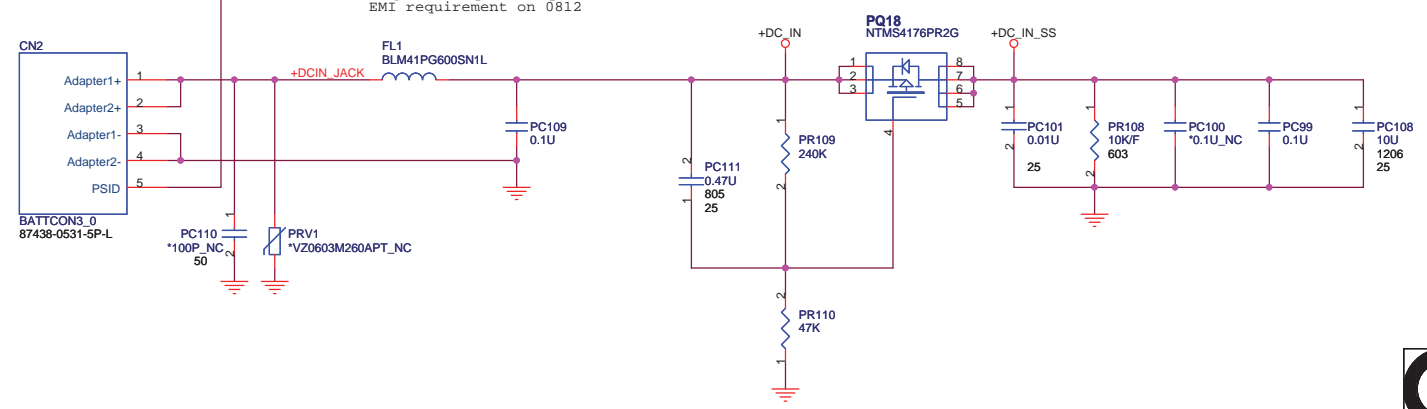
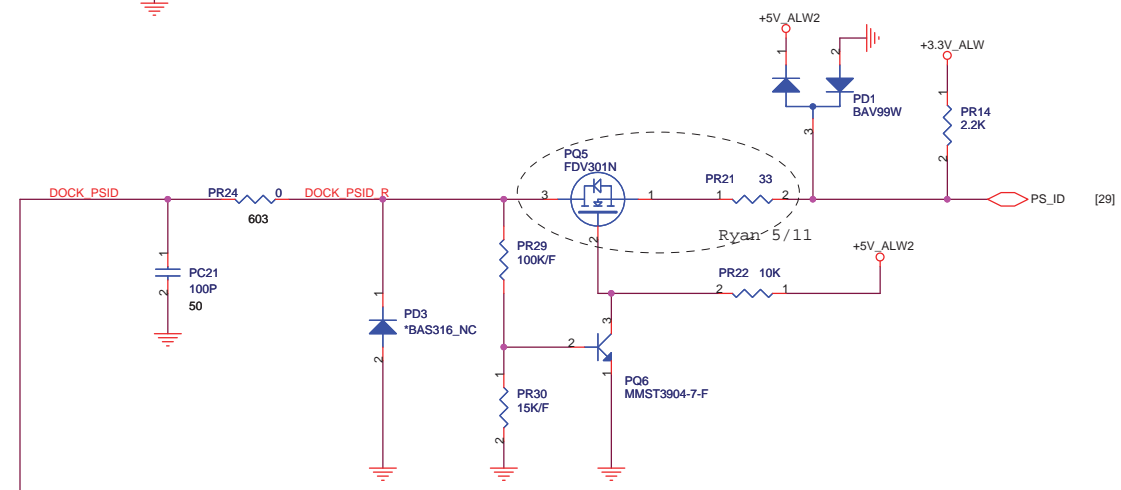
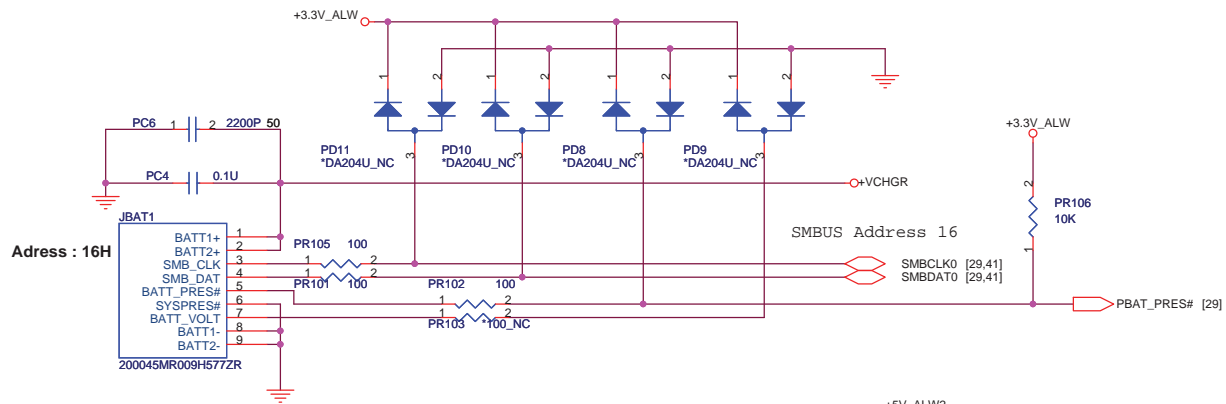

QUANTA COMPUTER

Title: DCIN,BATT CONNECTOR

Size: 11M8G Document Number: Rev 1B

Date: Tuesday, June 02, 2009 Sheet 47 of 53

<http://laptop-motherboard-schematic.blogspot.com/>

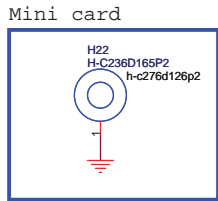
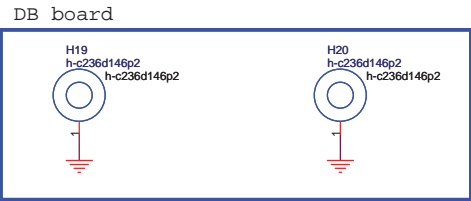
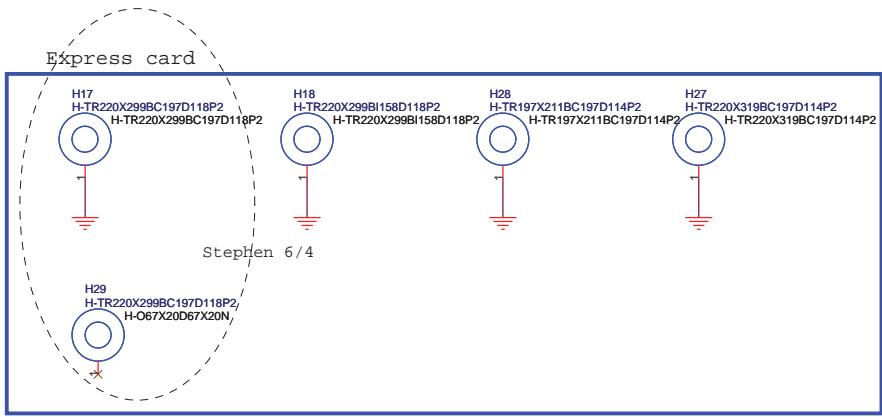
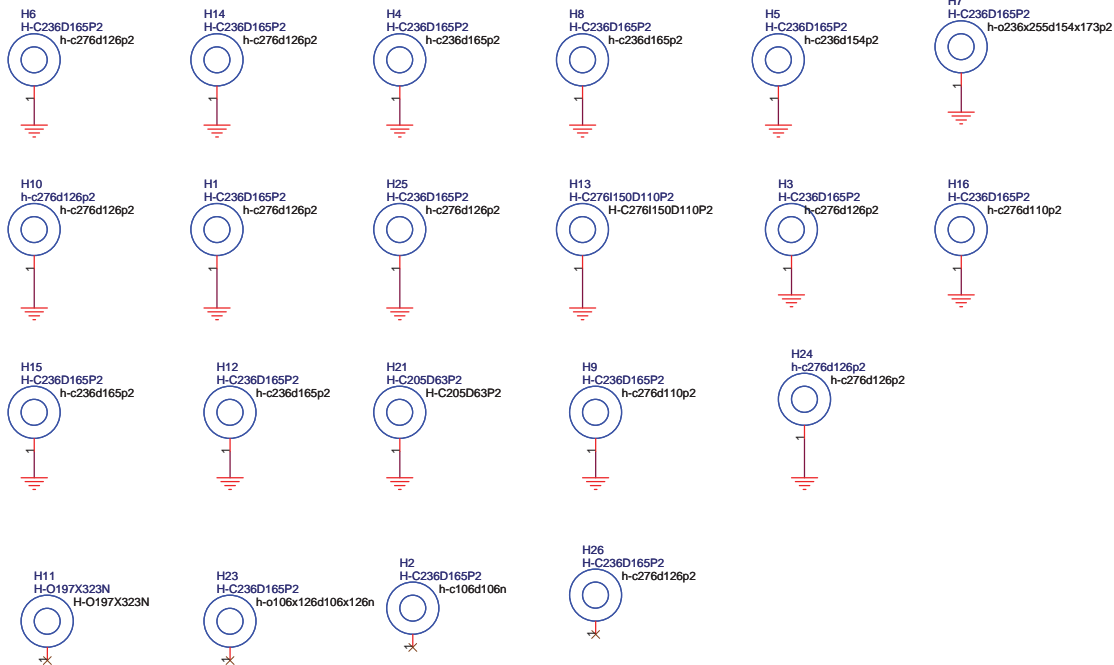

 QUANTA COMPUTER			
File: SCREW PAD			
Size	Document Number	Rev	
	VM8G	1B	
Date:	Saturday, June 06, 2009	Sheet	48 of 53

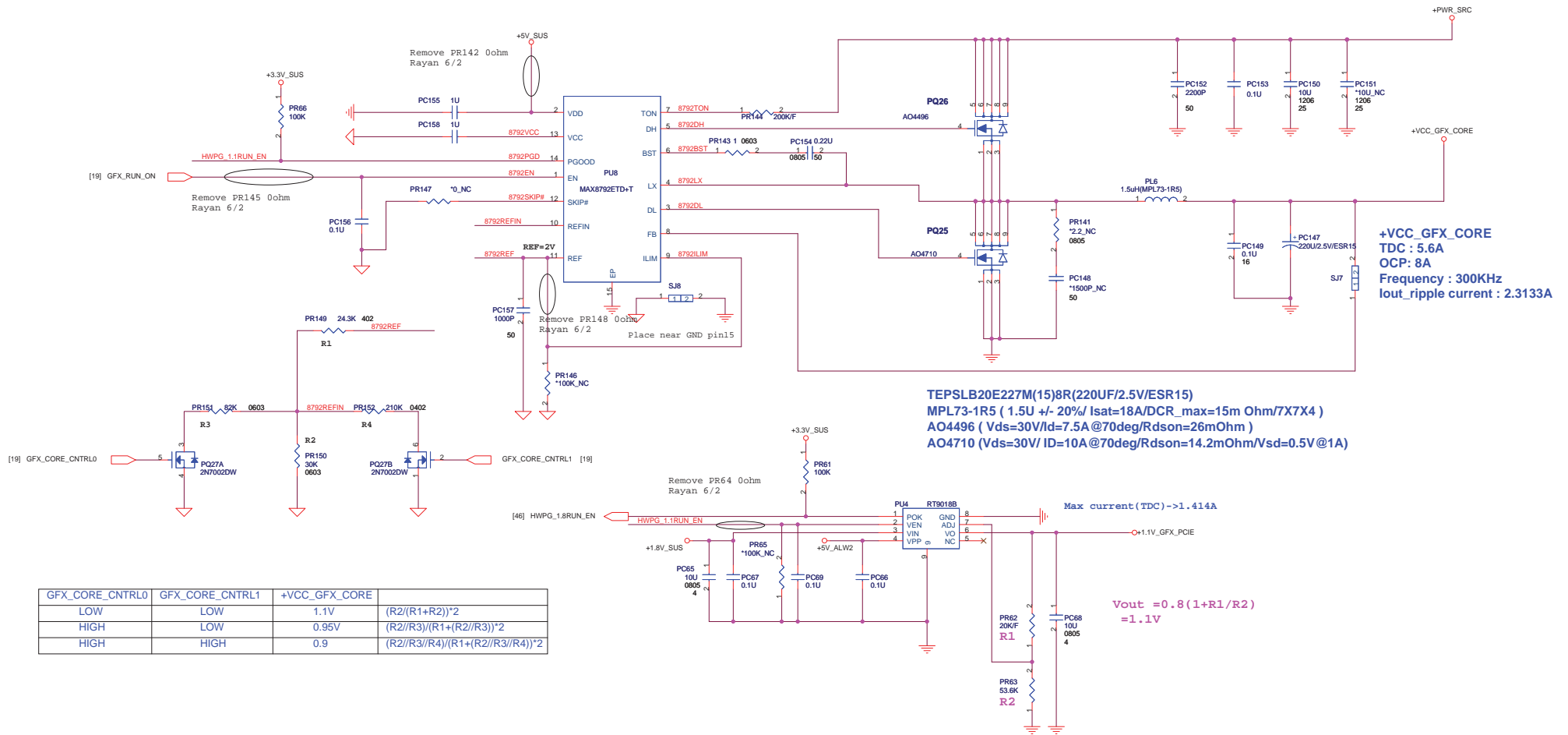

QUANTA COMPUTER

Title: +VCC_GFX_CORE(MAX8792)

Size: Document Number VMSG

Date: Saturday, June 06, 2009

Sheet: 49 of 53

Rev: 1B

Reserved for EMI.

		QUANTA COMPUTER	
Title		EMI CAP	
Size	Document Number	Rev	
	VM8G	1B	
Date:	Tuesday, June 02, 2009	Sheet	50 of 53

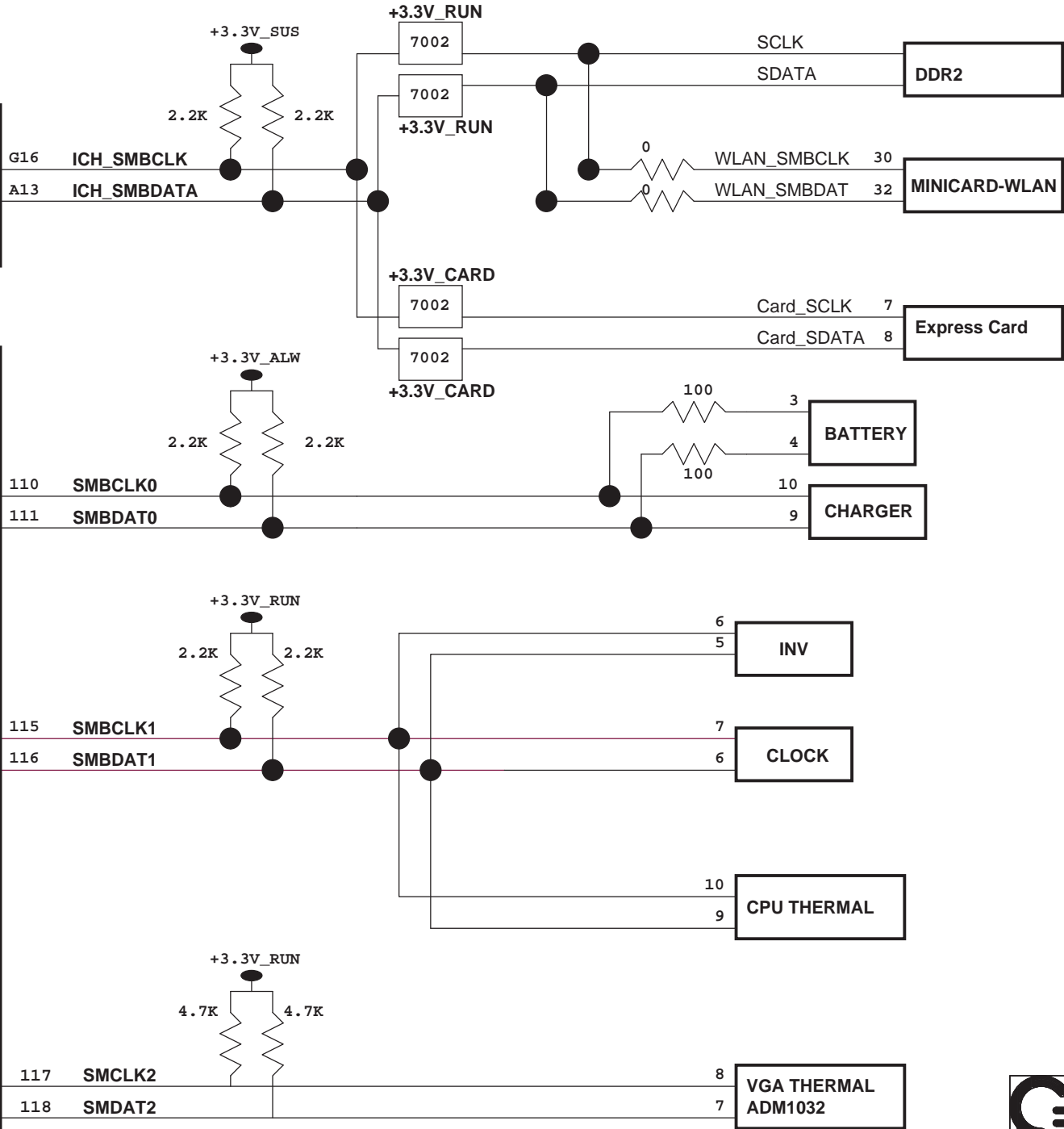

QUANTA COMPUTER

File: SMBUS BLOCK

Size	Document Number	Rev
	VM8G	1B

Date: Tuesday, June 02, 2009 Sheet 51 of 53

