

MODEL NAME : *PIM10*

PCB NO : *LA-6501P (DA60000I100)*

BOM P/N : *43190931L01*

# Compal Confidential

## Kenting Schematics Document

Intel Pine Trail-M ( Pineview-M + Tiger point )

2010-03-18

REV: 0.2

@ : Nopop Component

Security Classification	Compal Secret Data			Compal Electronics, Inc.		
Issued Date	2010/03/18	Deciphered Date	2011/03/18	Title		
				Cover Page		
THIS SHEET OF ENGINEERING DRAWING IS THE PROPRIETARY PROPERTY OF COMPAL ELECTRONICS, INC. AND CONTAINS CONFIDENTIAL AND TRADE SECRET INFORMATION. THIS SHEET MAY NOT BE TRANSFERRED FROM THE CUSTODY OF THE COMPETENT DIVISION OF R&D DEPARTMENT EXCEPT AS AUTHORIZED BY COMPAL ELECTRONICS, INC. NEITHER THIS SHEET NOR THE INFORMATION IT CONTAINS MAY BE USED BY OR DISCLOSED TO ANY THIRD PARTY WITHOUT PRIOR WRITTEN CONSENT OF COMPAL ELECTRONICS, INC.				Size Custom	Document Number LA-6501P	Rev 0.2
				Date:	Tuesday, April 27, 2010	Sheet 01 of 35

# Compal Confidential

Model Name : PIM10

Project Code : ANRPIM1000

Project Name : Kenting

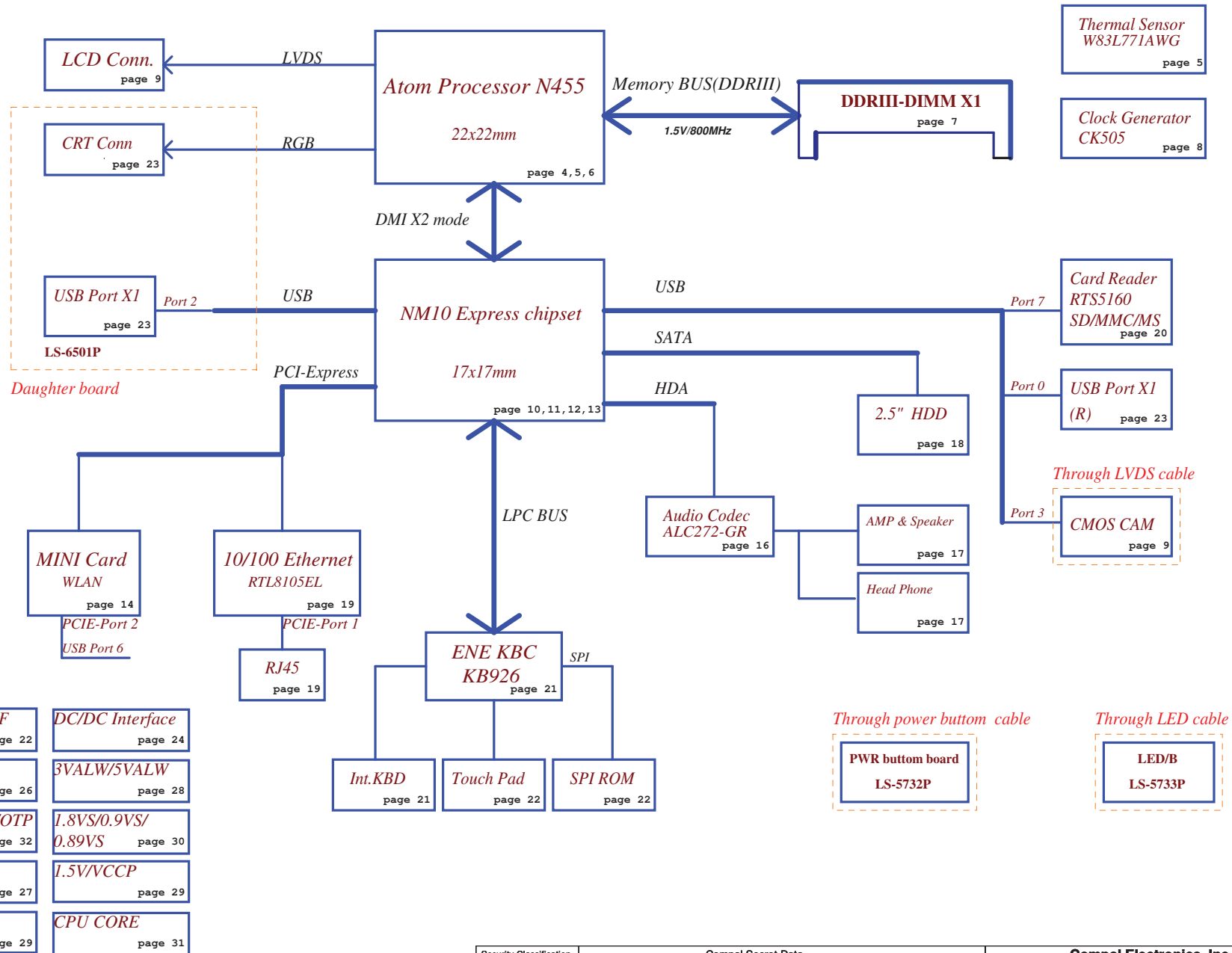

Power ON/OFF page 22	DC/DC Interface page 24
DC IN page 26	3VALW/5VALW page 28
BATT CONN/OTP page 32	I.8VS/0.9VS/ 0.89VS page 30
CHARGER page 27	I.5V/VCCP page 29
I.2VS page 29	CPU CORE page 31

Security Classification	Compal Secret Data		Compal Electronics, Inc.	
Issued Date	2010/03/18	Deciphered Date	2011/03/18	
THIS SHEET OF ENGINEERING DRAWING IS THE PROPRIETARY PROPERTY OF COMPAL ELECTRONICS, INC. AND CONTAINS CONFIDENTIAL AND TRADE SECRET INFORMATION. THIS SHEET MAY NOT BE TRANSFERRED FROM THE CUSTODY OF THE COMPETENT DIVISION OF R&D DEPARTMENT EXCEPT AS AUTHORIZED BY COMPAL ELECTRONICS, INC. NEITHER THIS SHEET NOR THE INFORMATION IT CONTAINS MAY BE USED BY OR DISCLOSED TO ANY THIRD PARTY WITHOUT PRIOR WRITTEN CONSENT OF COMPAL ELECTRONICS, INC.			Title	Block Diagrams
Size	Document Number	Rev	0.2	
Custom	LA-6501P	Date:	Monday, May 10, 2010	Sheet 02 of 35



DA600001100

### Voltage Rails

Power Plane	Description	S1	S3	S5
VIN	Adapter power supply (19V)	N/A	N/A	N/A
B+	AC or battery power rail for power circuit.	N/A	N/A	N/A
+CPU_CORE	Core voltage for CPU	ON	OFF	OFF
+0.75VS	0.9V switched power rail for DDR terminator	ON	OFF	OFF
+VCCP	VCCP switched power rail	ON	OFF	OFF
+1.5VS	1.5V switched power rail	ON	OFF	OFF
+1.5V	1.5V power rail for DDR	ON	ON	OFF
+1.8VS	1.8V switched power rail	ON	OFF	OFF
+0.89VS	CORE VOLTAGE FOR CPU VGA	ON	OFF	OFF
+3VALW	3.3V always on power rail	ON	ON	ON*
+3VS	3.3V switched power rail	ON	OFF	OFF
+5VALW	5V always on power rail	ON	ON	ON*
+5VS	5V switched power rail	ON	OFF	OFF
+VS	VS always on power rail	ON	ON	ON*
+RTCBATT	RTC power	ON	ON	ON

Note : ON\* means that this power plane is ON only with AC power available, otherwise it is OFF.

STATE \ SIGNAL	SLP_S3#	SLP_S4#	SLP_S5#	+VALW	+V	+VS	Clock
Full ON	HIGH	HIGH	HIGH	ON	ON	ON	ON
S1 (Power On Suspend)	HIGH	HIGH	HIGH	ON	ON	ON	LOW
S3 (Suspend to RAM)	LOW	HIGH	HIGH	ON	ON	OFF	OFF
S4 (Suspend to Disk)	LOW	LOW	HIGH	ON	OFF	OFF	OFF
S5 (Soft OFF)	LOW	LOW	LOW	ON	OFF	OFF	OFF

### BOARD ID Table(Page 21)

VCC	3.3V +/-5%					
ID	BRD ID	Ra	Rb	Vab (Min)	Vab (Type)	Vab (Max)
0	R01 (SSI)	NC	0	0V	0V	0.155V
1	R02 (PT)	100K +/- 5%	8.2K +/- 5%	0.168V	0.250V	0.362V
2	R03 (ST)	100K +/- 5%	18K +/- 5%	0.375V	0.503V	0.621V
3	R10 (X build)	100K +/- 5%	33K +/- 5%	0.634V	0.819V	0.945V
4	Reserved	100K +/- 5%	56K +/- 5%	0.958V	1.185V	1.359V
5	Reserved	100K +/- 5%	100K +/- 5%	1.372V	1.650V	1.838V
6	Reserved	100K +/- 5%	200K +/- 5%	1.851V	2.200V	2.420V
7	MP	100K +/- 5%	NC	2.433V	3.300V	3.300V

### External PCI Devices

DEVICE	IDSEL #	REQ/GNT #	PIRQ
--------	---------	-----------	------

No PCI Device

### EC SM Bus1 address

Device	Address
Smart Battery	0001 011X b
EEPROM(24C16/02)	1010 000X b

### EC SM Bus2 address

Device	Address
W83L771AWG	1001_100X b
EMC1402	100_1100X b

### Tiger Point SM Bus address

Device	Address
Clock Generator (SLG8SP556VTR)	1101 001Xb
DDR DIMMA	1010 000Xb

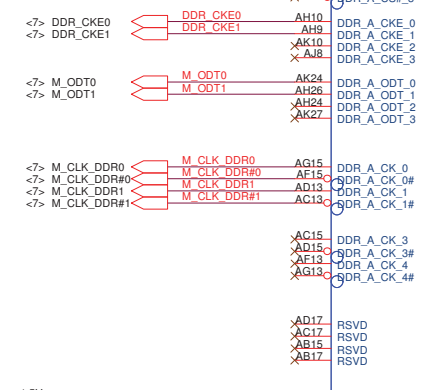
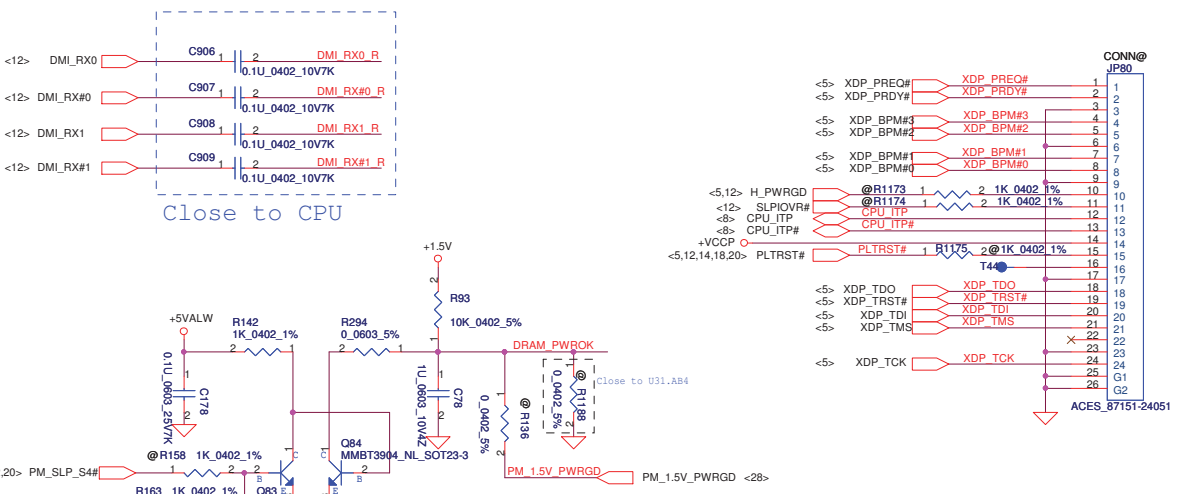
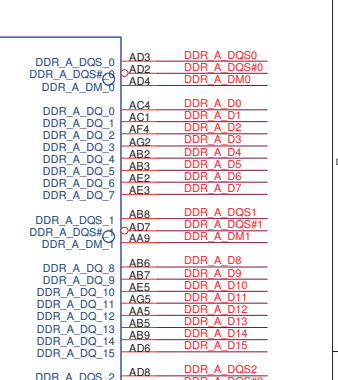
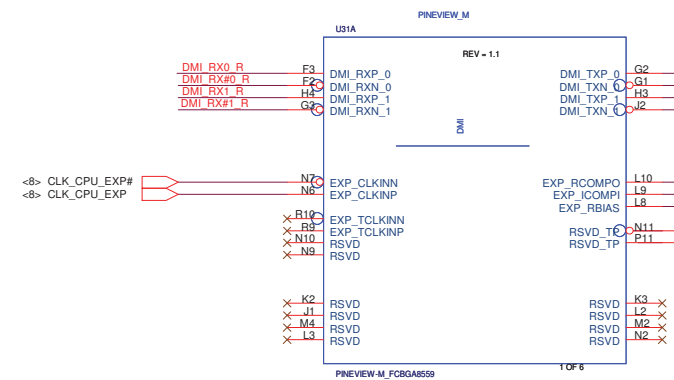

Signal Name	Description	Direction	Type
BCLKP[0]	Differential Core Clock In		
BCLKN[0]	Differential Core Clock In	I	Diff Clk CMOS
HPL_CLKINP	Differential Host Clock In	I	Diff Clk CMOS
HPL_CLKINN	Differential Host Clock In		
EXP_CLKINP	Differential DMI Clock In	I	Diff Clk CMOS
EXP_CLKINN	Differential DMI Clock In		
REFCLKINP	Differential PLL Clock In	I	Diff Clk CMOS
REFCLKINN	Differential PLL Clock In		
REFSSCLKINP	Differential Spread Spectrum Clock In	I	Diff Clk CMOS
REFSSCLKINN	Differential Spread Spectrum Clock In		

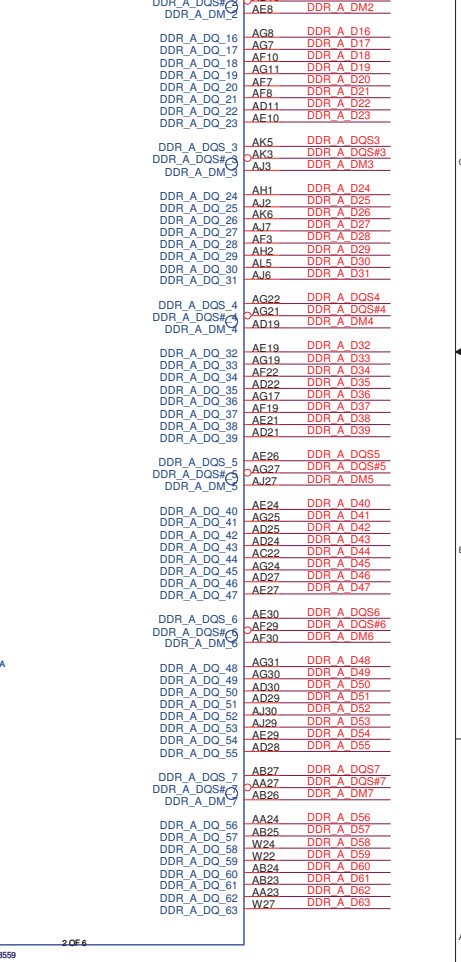
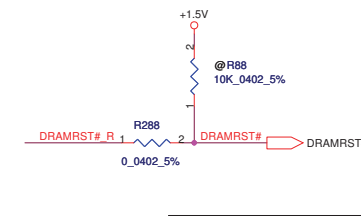
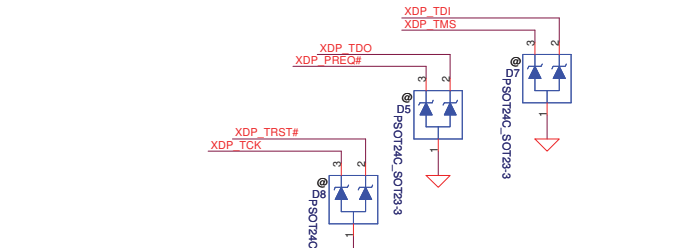
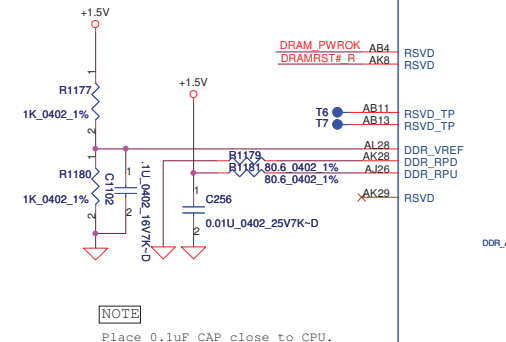
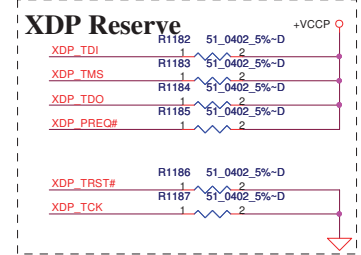

Security Classification	Compal Secret Data	
Issued Date	2010/03/18	Deciphered Date
		2011/03/18

Compal Electronics, Inc.			
Title			
Pineview(1/3)-DMI,DDR			
Size	Document Number	Rev	
Custom	LA-6501P	0.2	
Date:	Monday, May 10, 2010	Sheet	04 of 35

<http://hobi-elektronika.net>

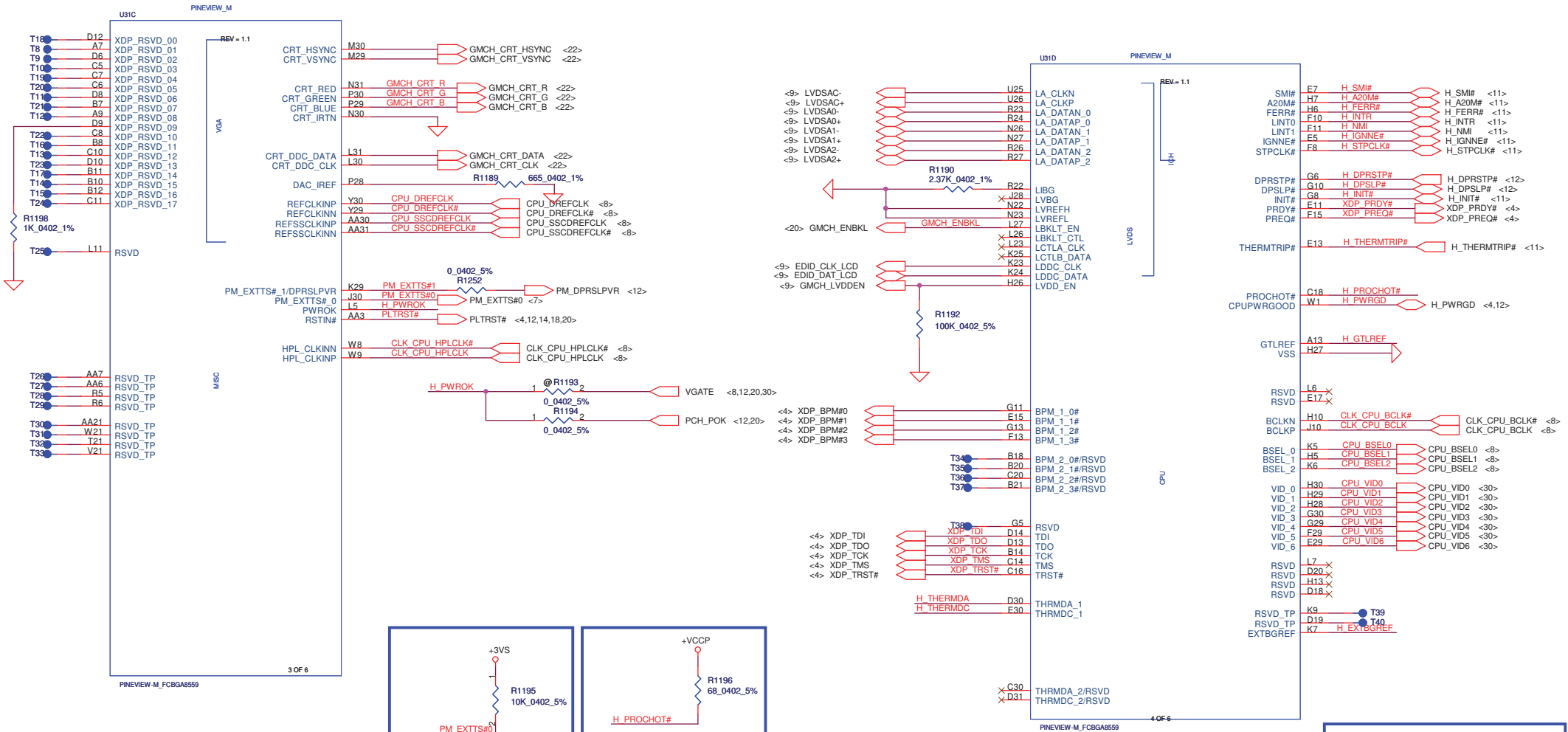

H\_THERMDA, H\_THERMDC routing together.  
Trace width / Spacing = 10 / 10 mil

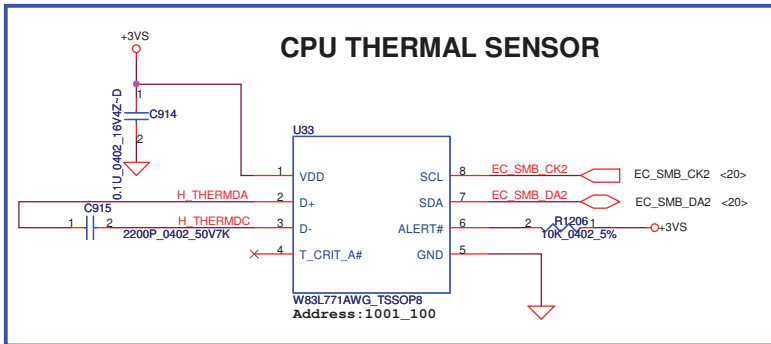
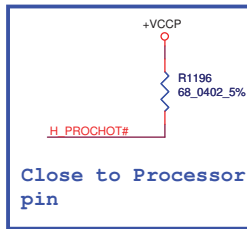
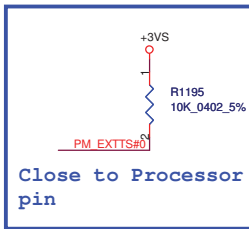

Place closed to chipset

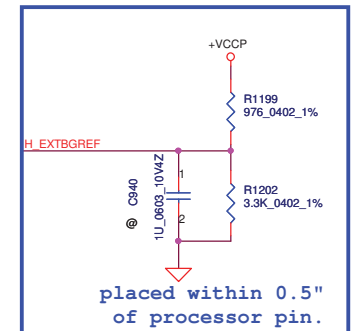
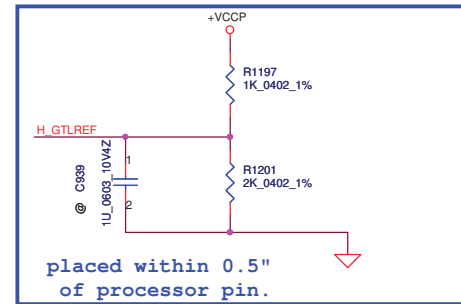
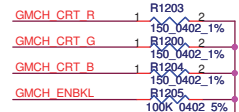

Security Classification		Compal Secret Data		Compal Electronics, Inc.	
Issued Date	2010/03/18	Deciphered Date	2011/03/18	Title	
THIS SHEET OF ENGINEERING DRAWING IS THE PROPRIETARY PROPERTY OF COMPAL ELECTRONICS, INC. AND CONTAINS CONFIDENTIAL AND TRADE SECRET INFORMATION. THIS SHEET MAY NOT BE TRANSFERRED FROM THE CUSTODY OF THE COMPETENT DIVISION OF R&D DEPARTMENT EXCEPT AS AUTHORIZED BY COMPAL ELECTRONICS, INC. NEITHER THIS SHEET NOR THE INFORMATION IT CONTAINS MAY BE USED BY OR DISCLOSED TO ANY THIRD PARTY WITHOUT PRIOR WRITTEN CONSENT OF COMPAL ELECTRONICS, INC.				Pineview(2/3)-HOST,CRT,LVDS	
Size	Document Number	Rev		0.2	
Custom	LA-6501P				
Date:	Monday, May 10, 2010	Sheet	05	of 35	

GFX supply current: 1.38A  
Sustained GFX supply current: 1.05A

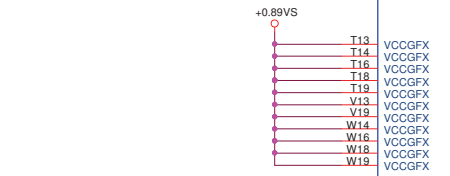

DDR supply current: 2.27A

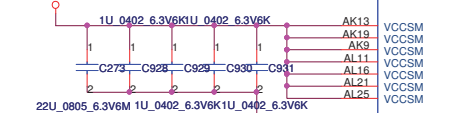

Display PLL SFR and CRT DAC supply current: 0.154A

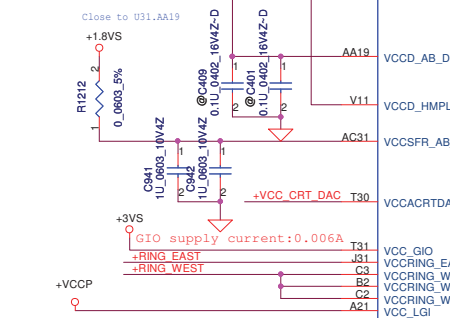

DAC, GIO, LVDS, & LGIO, DPLL, HMPLL supply current: 0.33A

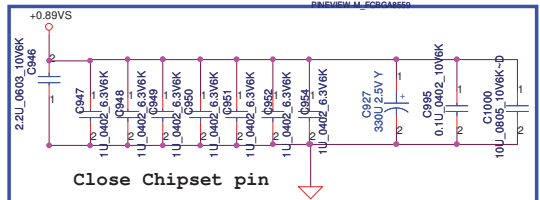

Close Chipset pin

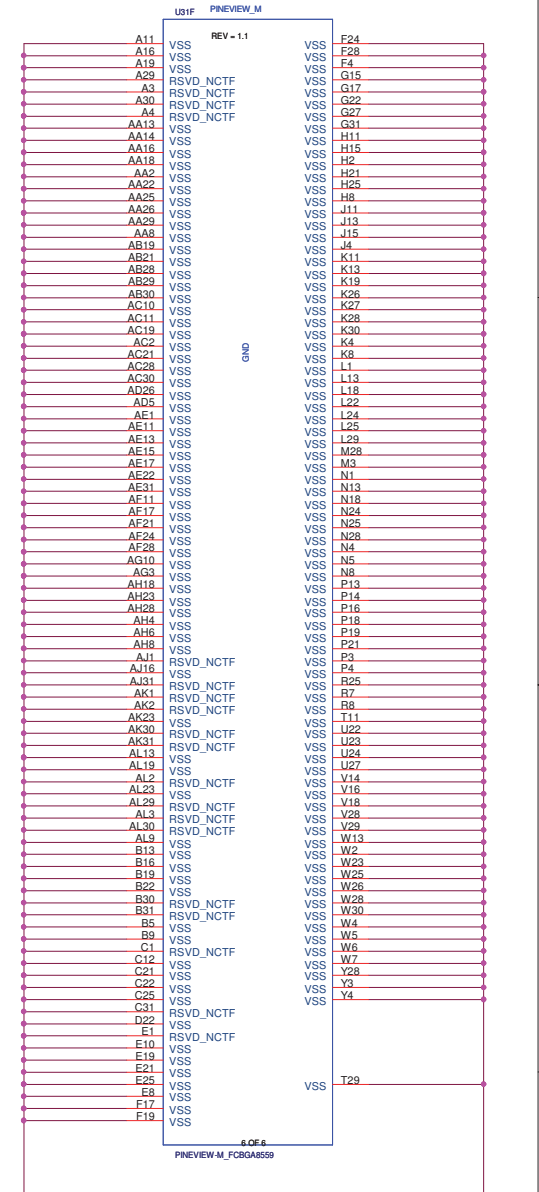
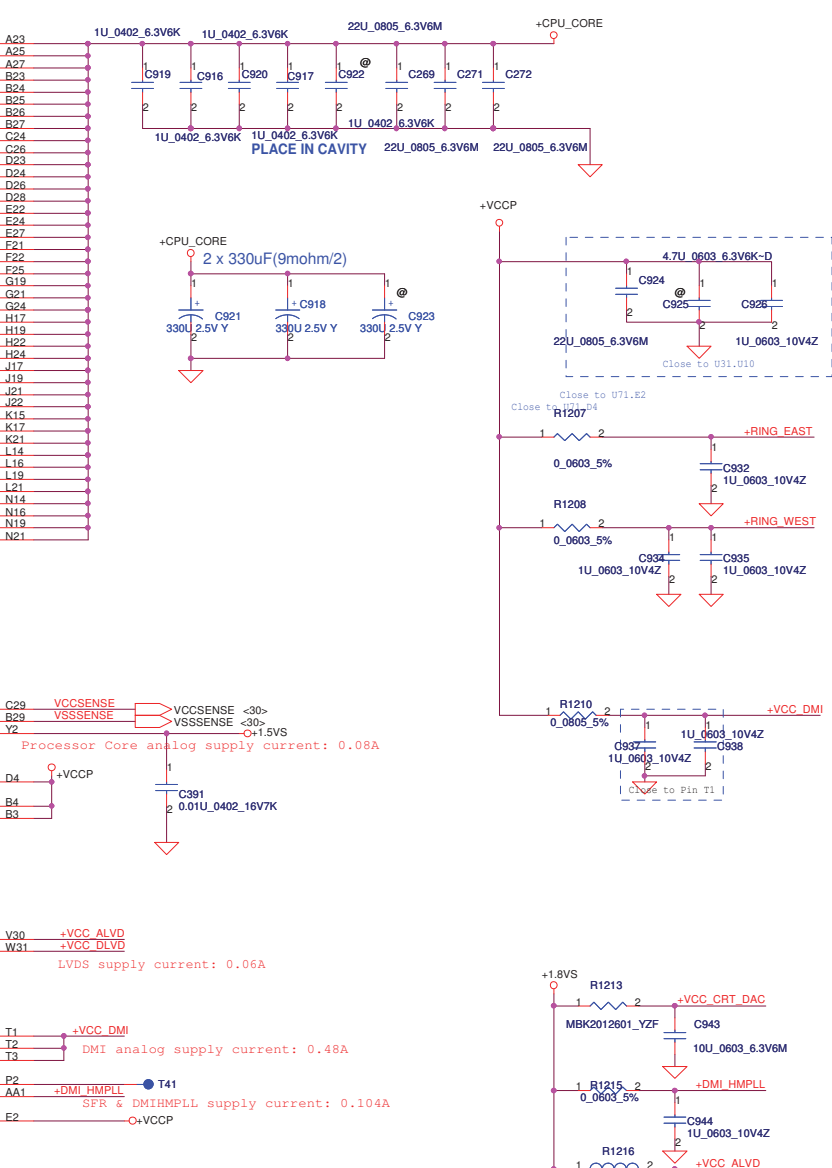
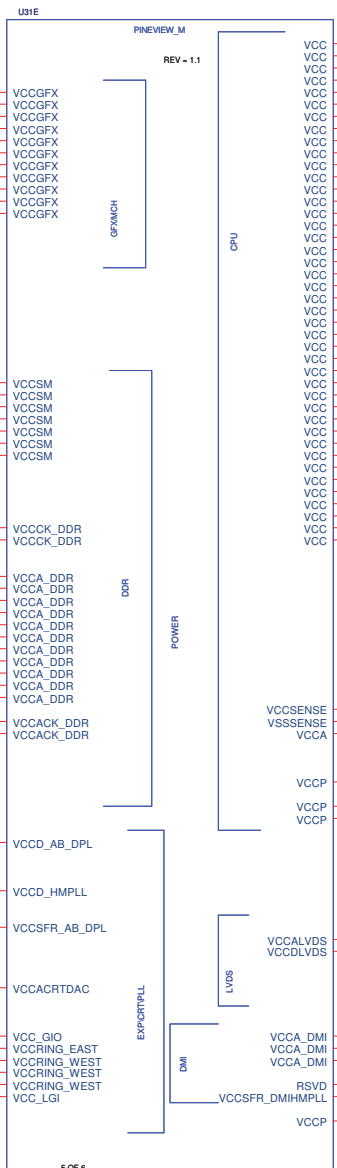

Security Classification	Compal Secret Data	
Issued Date	2010/03/18	Deciphered Date
		2011/03/18

THIS SHEET OF ENGINEERING DRAWING IS THE PROPRIETARY PROPERTY OF COMPAL ELECTRONICS, INC. AND CONTAINS CONFIDENTIAL AND TRADE SECRET INFORMATION. THIS SHEET MAY NOT BE TRANSFERRED FROM THE CUSTODY OF THE COMPETENT DIVISION OF R&D DEPARTMENT EXCEPT AS AUTHORIZED BY COMPAL ELECTRONICS, INC. NEITHER THIS SHEET NOR THE INFORMATION IT CONTAINS MAY BE USED BY OR DISCLOSED TO ANY THIRD PARTY WITHOUT PRIOR WRITTEN CONSENT OF COMPAL ELECTRONICS, INC.

Compal Electronics, Inc.		
Title Pineview(3/3)-POWER,GND		
Size Custom	Document Number LA-6501P	Rev 0.2
Date: Monday, May 10, 2010	Sheet 06	of 35

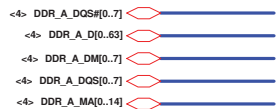

Layout Note:  
Place near JDIMM1.1

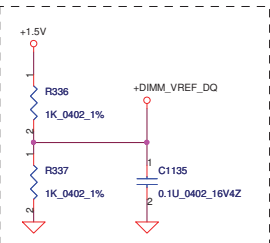

Layout Note:  
Place near JDIMM1.126

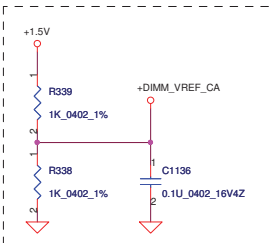

Layout Note:  
Place near JDIMM1

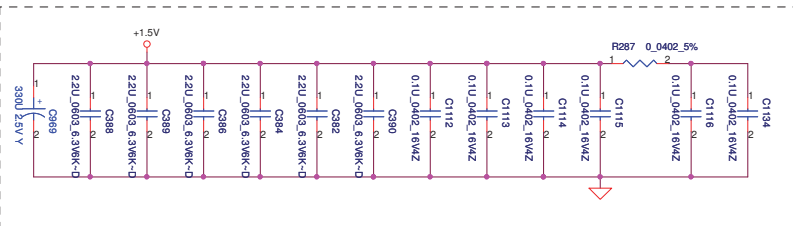

Layout Note:  
Place near JDIMM1.203 & JDIMM1.204

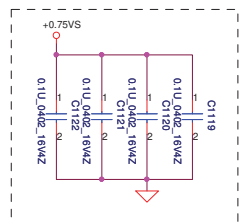

Layout Note:  
Place near JDIMM1

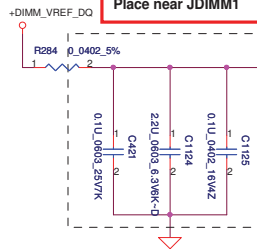

20mils

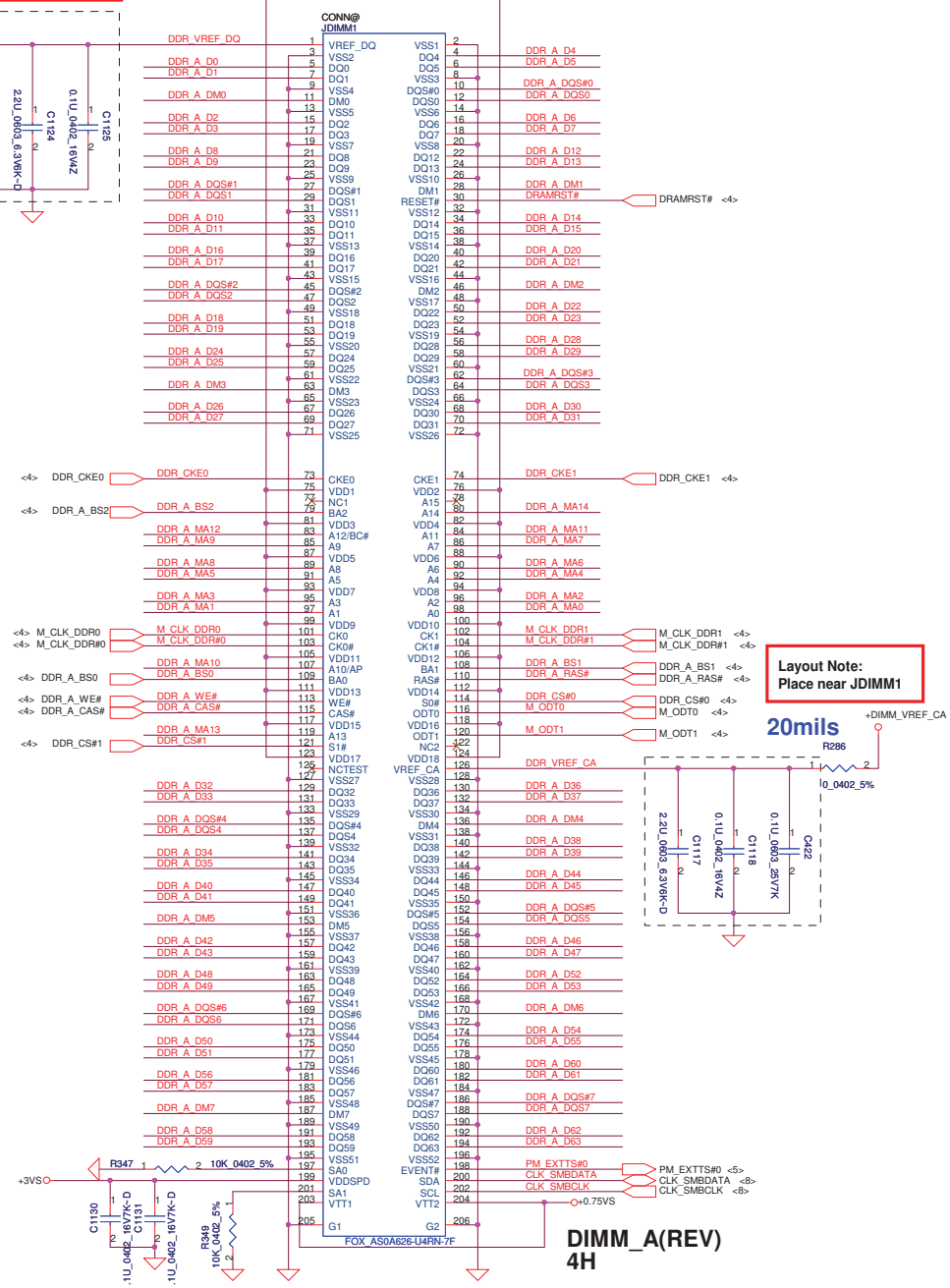

Layout Note:  
Place near JDIMM1

20mils

DIMM\_A(REV)  
4H

Security Classification		Compal Secret Data		Compal Electronics, Inc.	
Issued Date	2010/03/18	Deciphered Date	2011/03/18	Title	DDRIII-SODIMM A
THIS SHEET OF ENGINEERING DRAWING IS THE PROPRIETARY PROPERTY OF COMPAL ELECTRONICS, INC. AND CONTAINS CONFIDENTIAL AND TRADE SECRET INFORMATION. THIS SHEET MAY NOT BE TRANSFERRED FROM THE CUSTODY OF THE PROPRIETARY DIVISION OF R&D DEPARTMENT EXCEPT AS AUTHORIZED BY COMPAL ELECTRONICS, INC. NEITHER THIS SHEET NOR THE INFORMATION IT CONTAINS MAY BE USED BY OR DISCLOSED TO ANY THIRD PARTY WITHOUT PRIOR WRITTEN CONSENT OF COMPAL ELECTRONICS, INC.					
Size	Document Number	Rev			
Custom	LA-6501P	0.2			
Date:	Friday, May 07, 2010	Sheet	07	of	35

FSC CLKSEL2	FSB CLKSEL1	FSA CLKSEL0	CPU MHz	SRC MHz	PCI MHz	REF MHz	DOT_96 MHz	USB MHz
0	0	0	266	100	33.3	14.318	96.0	48.0
0	0	1	133	100	33.3	14.318	96.0	48.0
0	1	0	200	100	33.3	14.318	96.0	48.0
0	1	1	166	100	33.3	14.318	96.0	48.0
1	0	0	333	100	33.3	14.318	96.0	48.0
1	0	1	100	100	33.3	14.318	96.0	48.0
1	1	0	400	100	33.3	14.318	96.0	48.0
1	1	1						
Reserved								

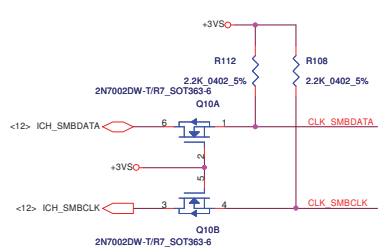
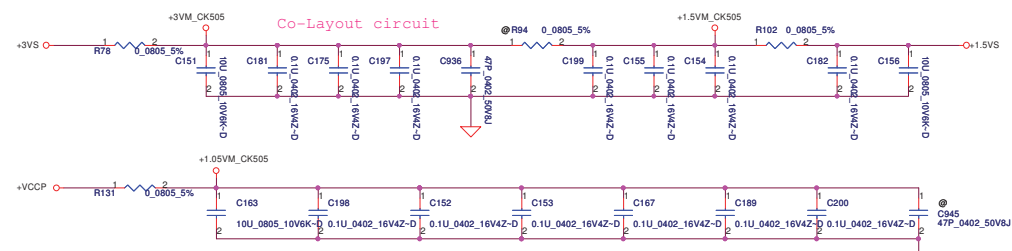

**SA0003H720 (Realtek : RTM890N-397-VB-GRT)**  
**SA000020H10 (ICS : ICS9LPRS387AKLFT)**

Manufacturer	Power	Component List
Realtek (L.P.)	+3VS, +1.5VS	De-pop R94, R118; pop R102, C182, C156, C936, R116
ICS (L.P.)	+3VS, +1.5VS	De-pop R94, R116; pop R102, C182, C156, C936, R118
ICS, Silego	+3VS	De-pop R102, C182, C156, C936, R118; pop R94, R116

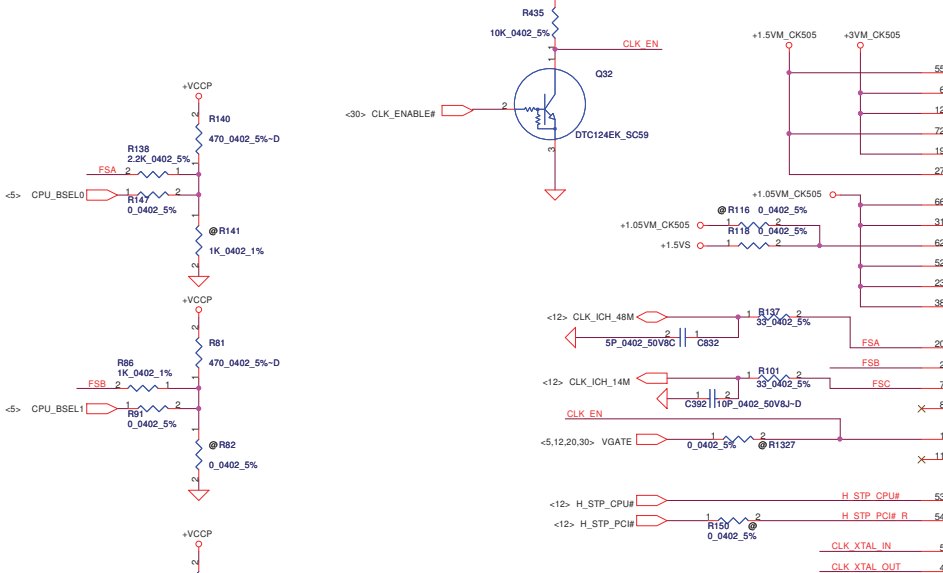

**Schematic Note:**  
 33 ohm series-resistor need add for signal end clock.

For ITP\_EN, 0 = SRC8/SRC8#; 1 = ITP/ITP#  
 For PCI4\_SEL, 0 = Pin24/25 : DOT96 / DOT96#  
 Pin28/29 : LCDCLK / LCDCLK#  
 1 = Pin24/25 : SRC 0 / SRC\_0#  
 Pin28/29 : 27M/27M\_SS  
 For PCI2\_TME: 0=Overclocking of CPU and SRC allowed  
 (ICS only) 1=Overclocking of CPU and SRC NOT allowed

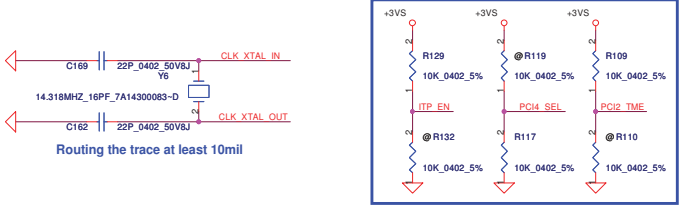

Routing the trace at least 10mil

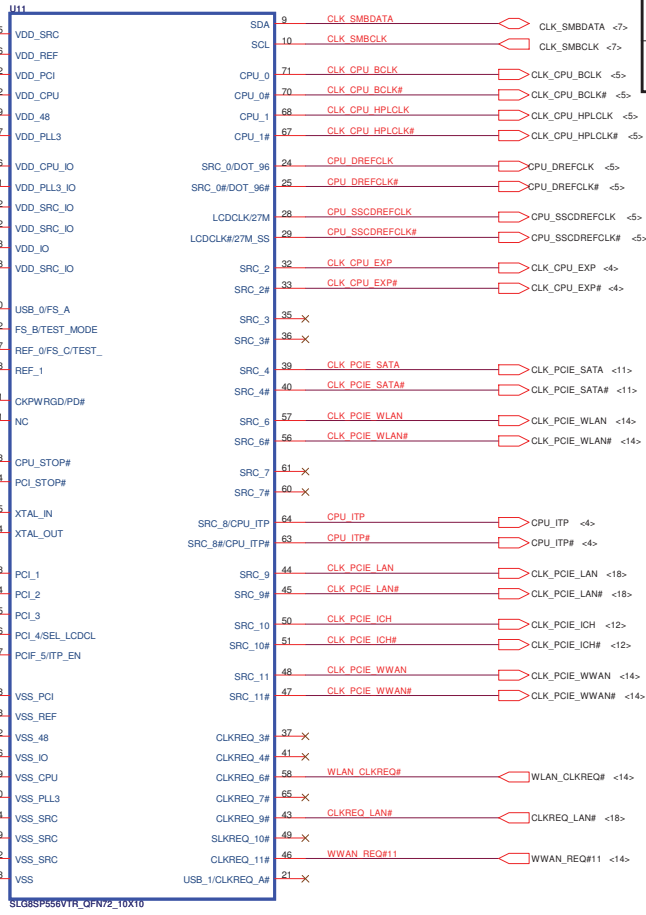

**SRC PORT LIST**

PORT	DEVICE
SRC0	CPU_VGA
SRC2	DMI
SRC3	PCI_E_SATA
SRC4	PCI_E_WLAN
SRC6	CPU_XDP
SRC7	PCI_E_SATA
SRC8	PCI_E_WLAN
SRC9	PCI_E_SATA
SRC10	PCI_E_WLAN
SRC11	PCI_E_SATA

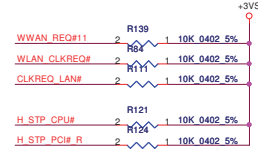

**REQ PORT LIST**

PORT	DEVICE
REQ_3#	
REQ_4#	
REQ_6#	PCI_E_WLAN
REQ_7#	
REQ_9#	PCI_E_LAN
REQ_10#	
REQ_11#	
REQ_A#	

Security Classification	Compal Secret Data		Compal Electronics, Inc.	
Issued Date	2010/03/18	Deciphered Date	2011/03/18	Title
THIS SHEET OF ENGINEERING DRAWING IS THE PROPRIETARY PROPERTY OF COMPAL ELECTRONICS, INC. AND CONTAINS CONFIDENTIAL AND TRADE SECRET INFORMATION. THIS SHEET MAY NOT BE TRANSFERRED FROM THE CUSTODY OF THE COMPETENT DIVISION OF R&D DEPARTMENT EXCEPT AS AUTHORIZED BY COMPAL ELECTRONICS, INC. NEITHER THIS SHEET NOR THE INFORMATION IT CONTAINS MAY BE USED BY OR DISCLOSED TO ANY THIRD PARTY WITHOUT PRIOR WRITTEN CONSENT OF COMPAL ELECTRONICS, INC.				Document Number <b>LA-6501P</b>
Date:	Friday, May 07, 2010	Sheet	06	of 35



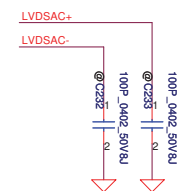
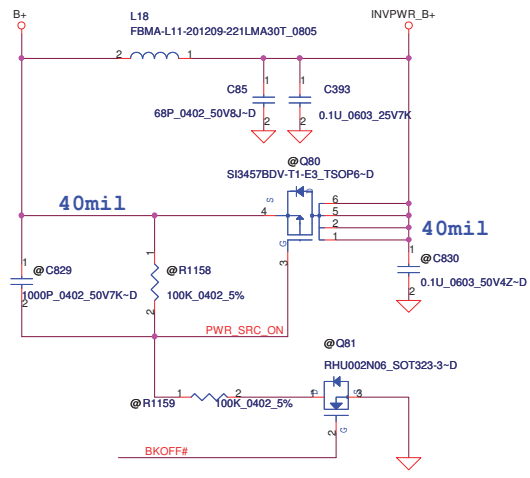
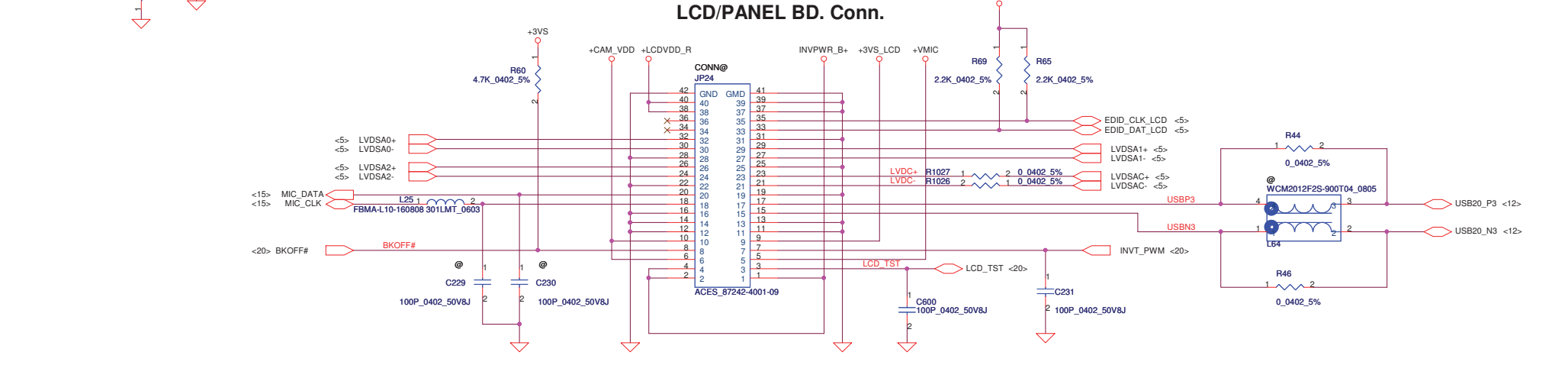
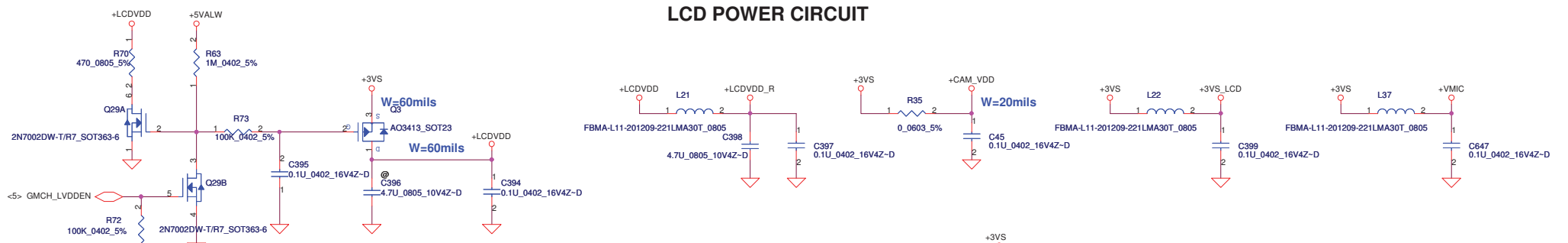

Security Classification	Compal Secret Data		Compal Electronics, Inc.	
Issued Date	2010/03/18	Deciphered Date	2011/03/18	Title
				LVDS/INVERTER
THIS SHEET OF ENGINEERING DRAWING IS THE PROPRIETARY PROPERTY OF COMPAL ELECTRONICS, INC. AND CONTAINS CONFIDENTIAL AND TRADE SECRET INFORMATION. THIS SHEET MAY NOT BE TRANSFERRED FROM THE CUSTODY OF THE COMPETENT DIVISION OF R&D DEPARTMENT EXCEPT AS AUTHORIZED BY COMPAL ELECTRONICS, INC. NEITHER THIS SHEET NOR THE INFORMATION IT CONTAINS MAY BE USED BY OR DISCLOSED TO ANY THIRD PARTY WITHOUT PRIOR WRITTEN CONSENT OF COMPAL ELECTRONICS, INC.				Size
				Document Number
				LA-6501P
				Rev
				0.2
				Date
				Friday, May 07, 2010
				Sheet
				09 of 35

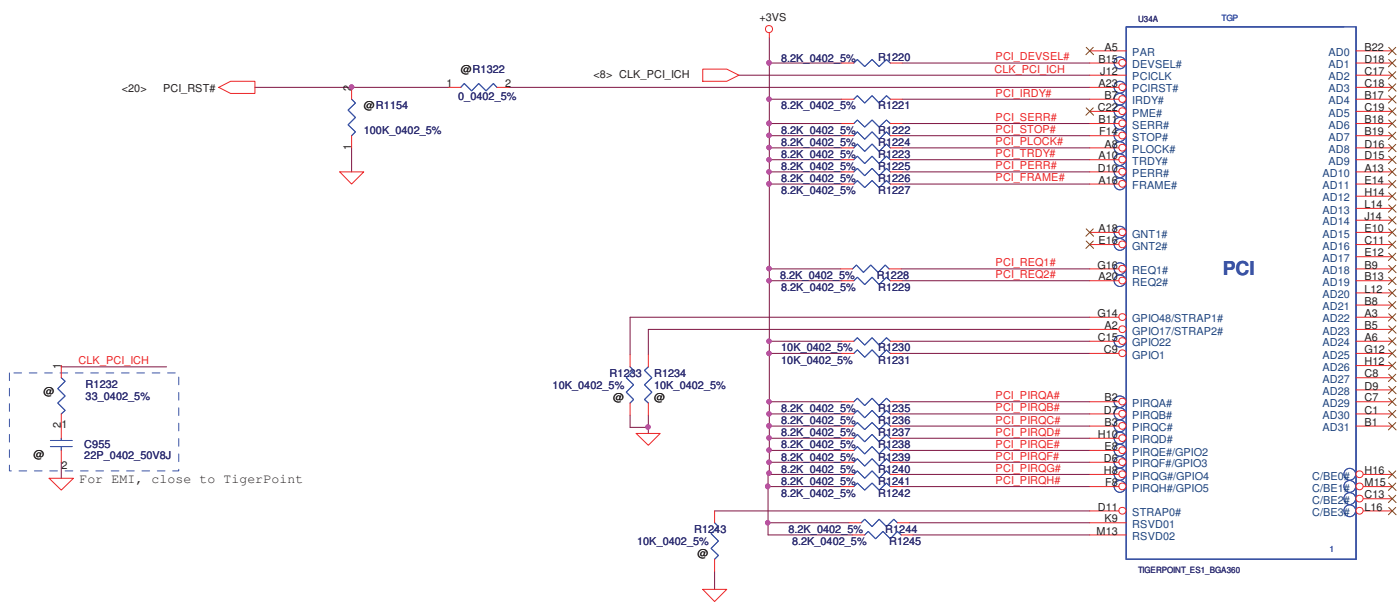

Security Classification		Compal Secret Data		Title		
Issued Date	2010/03/18	Deciphered Date	2011/03/18	Tigerpoint(1/4)-PCI		
THIS SHEET OF ENGINEERING DRAWING IS THE PROPRIETARY PROPERTY OF COMPAL ELECTRONICS, INC. AND CONTAINS CONFIDENTIAL AND TRADE SECRET INFORMATION. THIS SHEET MAY NOT BE TRANSFERRED FROM THE CUSTODY OF THE COMPETENT DIVISION OF R&D DEPARTMENT EXCEPT AS AUTHORIZED BY COMPAL ELECTRONICS, INC. NEITHER THIS SHEET NOR THE INFORMATION IT CONTAINS MAY BE USED BY OR DISCLOSED TO ANY THIRD PARTY WITHOUT PRIOR WRITTEN CONSENT OF COMPAL ELECTRONICS, INC.				Size	Document Number	Rev
					LA-6501P	0.2
				Date:	Friday, May 07, 2010	Sheet 10 of 35

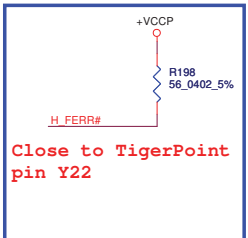
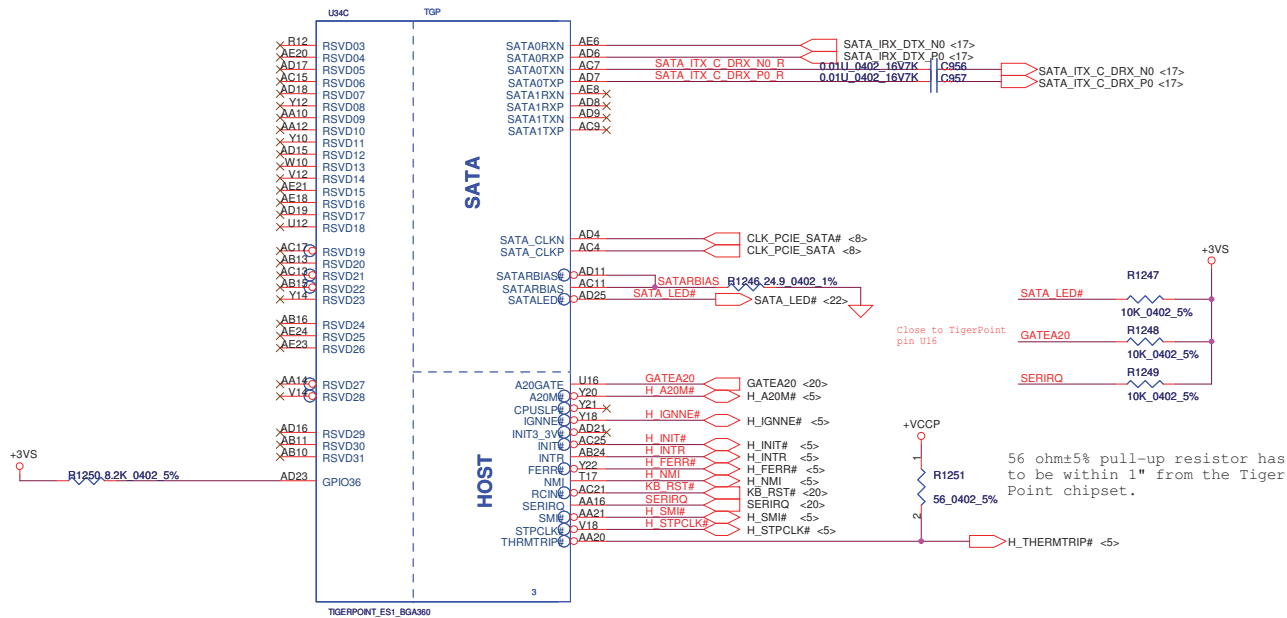

ESD request

H_A20M#	C450@	2	100P_0402_50V8J
H_IGNNE#	C451@	2	100P_0402_50V8J
H_INIT#	C452@	2	100P_0402_50V8J
H_INTR#	C453@	2	100P_0402_50V8J
H_FERR#	C454@	2	100P_0402_50V8J
H_NMI	C455@	2	100P_0402_50V8J
H_SMI#	C456@	2	100P_0402_50V8J
H_STPCLK#	C457@	2	100P_0402_50V8J

Security Classification	Compal Secret Data		Compal Electronics, Inc.	
Issued Date	2010/03/18	Deciphered Date	2011/03/18	
THIS SHEET OF ENGINEERING DRAWING IS THE PROPRIETARY PROPERTY OF COMPAL ELECTRONICS, INC. AND CONTAINS CONFIDENTIAL AND TRADE SECRET INFORMATION. THIS SHEET MAY NOT BE TRANSFERRED FROM THE CUSTODY OF THE COMPETENT DIVISION OF R&D DEPARTMENT EXCEPT AS AUTHORIZED BY COMPAL ELECTRONICS, INC. NEITHER THIS SHEET NOR THE INFORMATION IT CONTAINS MAY BE USED BY OR DISCLOSED TO ANY THIRD PARTY WITHOUT PRIOR WRITTEN CONSENT OF COMPAL ELECTRONICS, INC.			Title	Tigerpoint(2/4)-HOST,SATA
Size	Document Number	Rev	LA-6501P	
Date:	Friday, May 07, 2010	Sheet	11	of 35

USB Port List	
0	USB1 (Right)
1	
2	USB2 (Left)
3	Camera
4	
5	
6	WLAN + BT
7	CardReader

PCIe Port List	
1	LAN
2	WLAN
3	

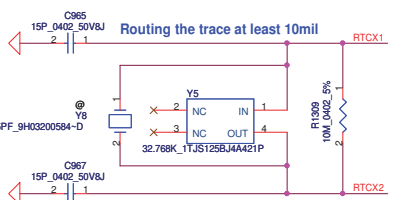
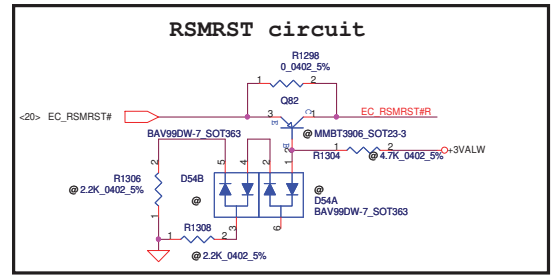
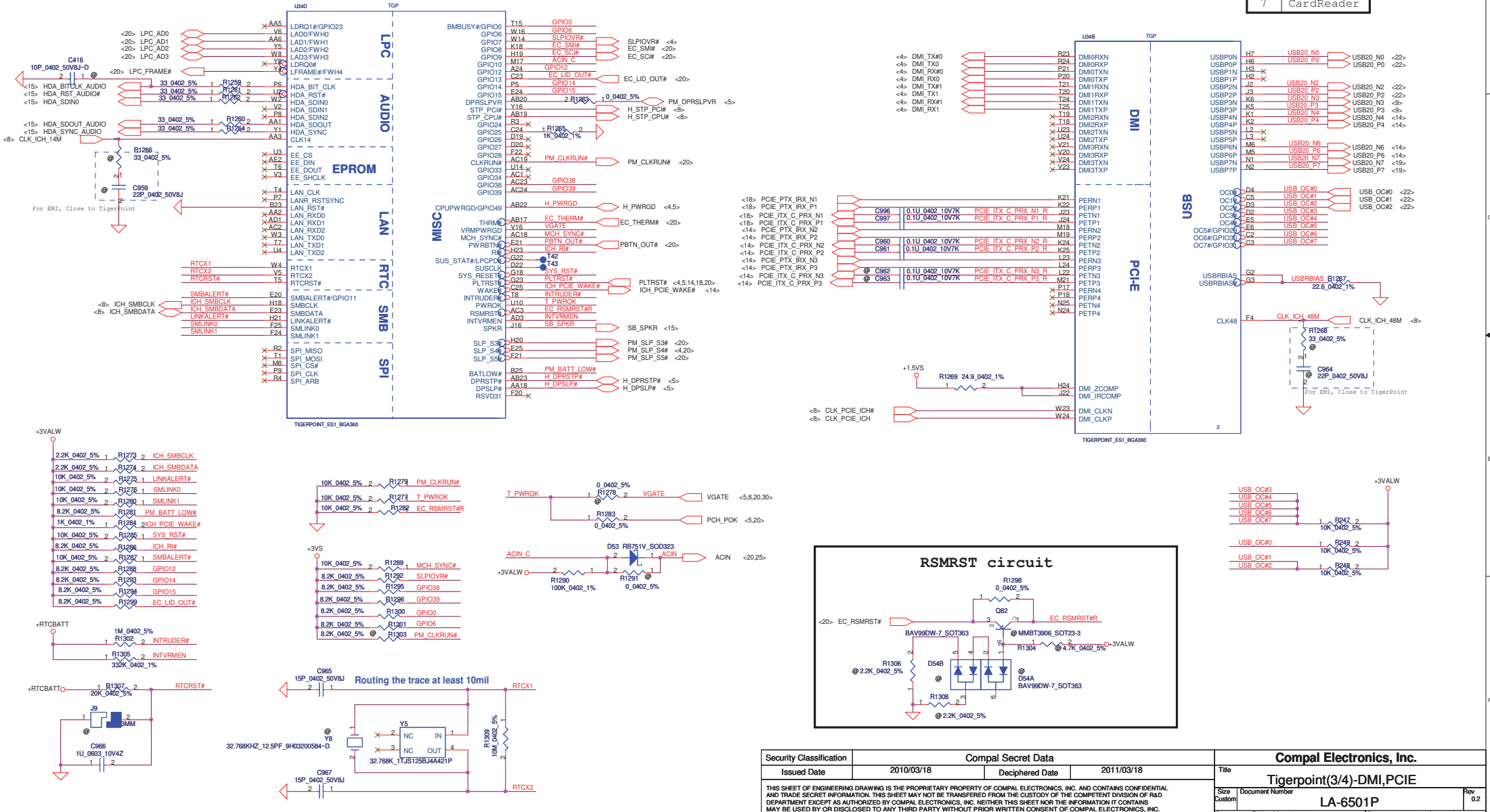

Security Classification		Compal Secret Data		Title	
Issued Date	2010/03/18	Deciphered Date	2011/03/18	Compal Electronics, Inc.	
THIS SHEET OF ENGINEERING DRAWING IS THE PROPRIETARY PROPERTY OF COMPAL ELECTRONICS, INC. AND CONTAINS CONFIDENTIAL AND TRADE SECRET INFORMATION. THIS SHEET MAY NOT BE TRANSFERRED FROM THE CUSTODY OF THE COMPETENT DIVISION OF R&D DEPARTMENT EXCEPT AS AUTHORIZED BY COMPAL ELECTRONICS, INC. NEITHER THIS SHEET NOR THE INFORMATION IT CONTAINS MAY BE USED BY OR DISCLOSED TO ANY THIRD PARTY WITHOUT PRIOR WRITTEN CONSENT OF COMPAL ELECTRONICS, INC.				Tigerpoint(3/4)-DMI,PCIe	
Size	Document Number	Rev		0.2	
Customer	LA-6501P	Date:	Friday, May 07, 2010	ISheet	12 of 35

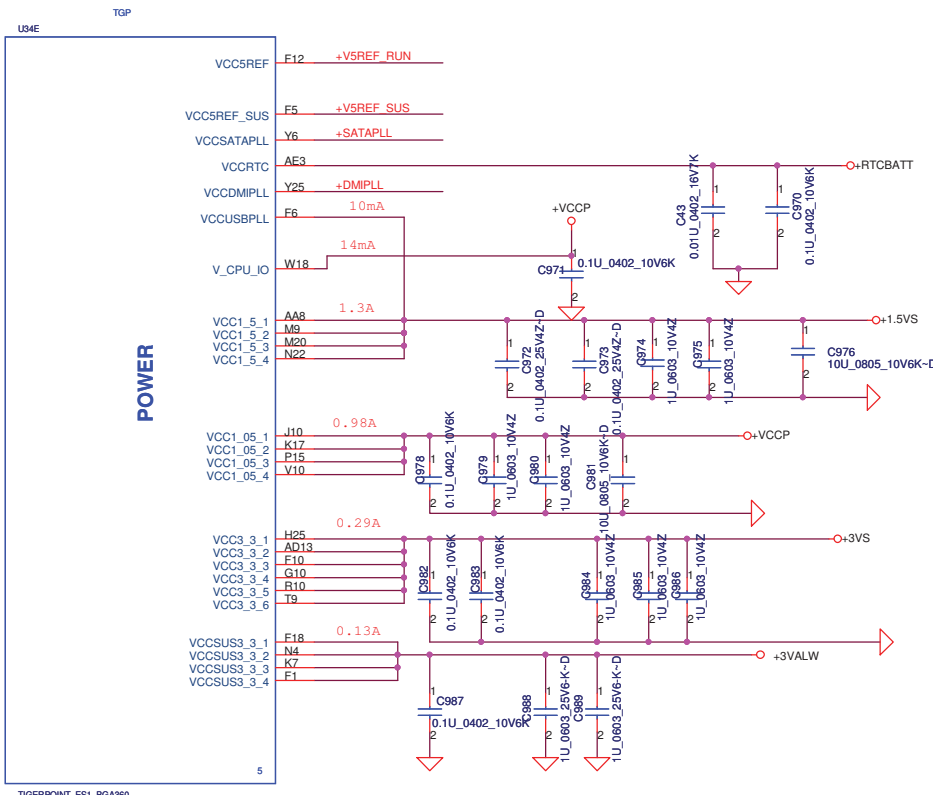
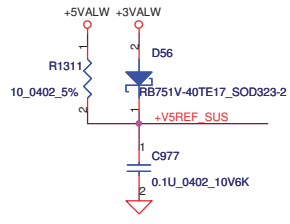
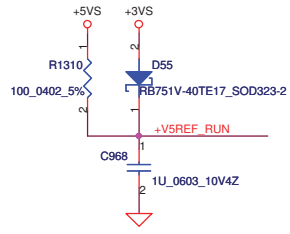

TIGERPOINT\_ES1\_BGA360

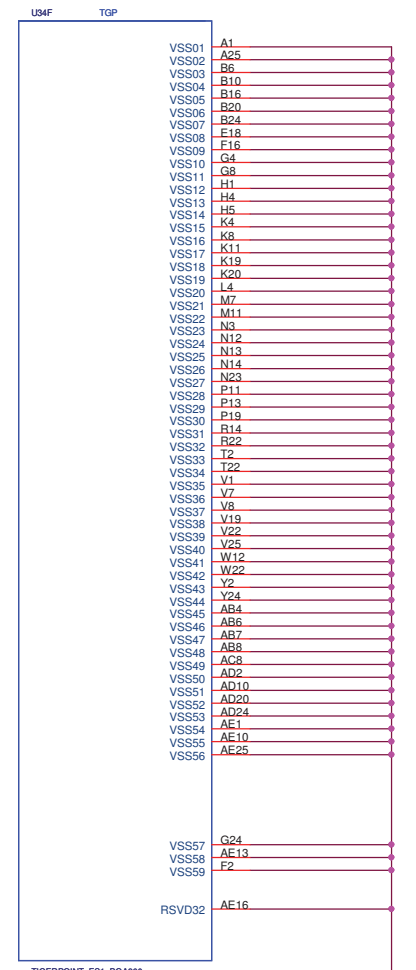

TIGERPOINT\_ES1\_BGA360

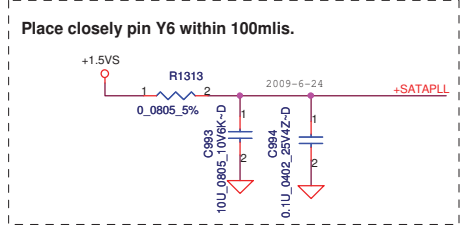
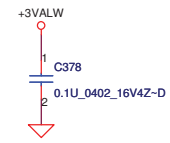
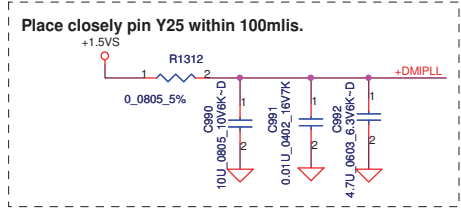

Security Classification	Compal Secret Data		
Issued Date	2010/03/18	Deciphered Date	2011/03/18
THIS SHEET OF ENGINEERING DRAWING IS THE PROPRIETARY PROPERTY OF COMPAL ELECTRONICS, INC. AND CONTAINS CONFIDENTIAL AND TRADE SECRET INFORMATION. THIS SHEET MAY NOT BE TRANSFERRED FROM THE CUSTODY OF THE COMPETENT DIVISION OF R&D DEPARTMENT EXCEPT AS AUTHORIZED BY COMPAL ELECTRONICS, INC. NEITHER THIS SHEET NOR THE INFORMATION IT CONTAINS MAY BE USED BY OR DISCLOSED TO ANY THIRD PARTY WITHOUT PRIOR WRITTEN CONSENT OF COMPAL ELECTRONICS, INC.			

Compal Electronics, Inc.			
Title Tigerpoint(4/4)-Power_GND			
Size Custom	Document Number LA-6501P	Rev 0.2	
Date: Monday, May 10, 2010	Sheet 13	of 35	

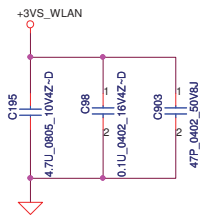

### Mini-Express Card for WLAN

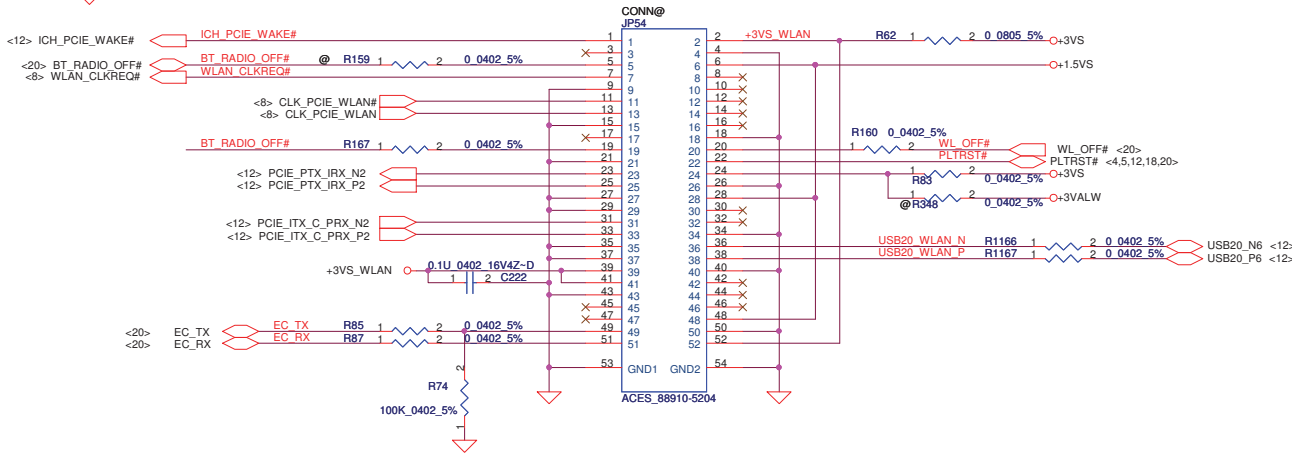

Layout Note:  
Place near JP54

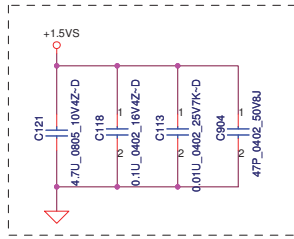

### SIM Interface

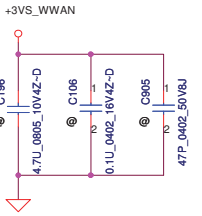
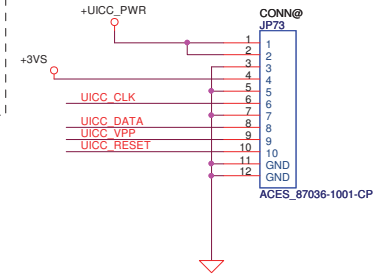

### Mini-Express Card for WWAN

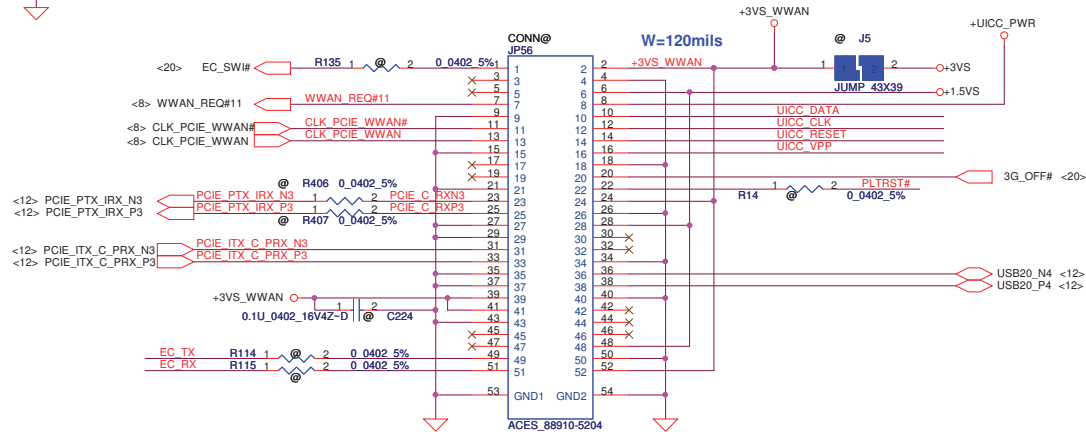

Layout Note:  
Place near JP56

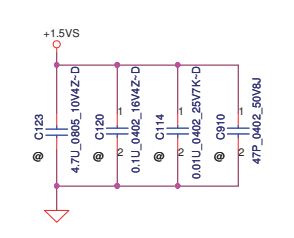

Security Classification		Compal Secret Data		Compal Electronics, Inc.	
Issued Date	2010/03/18	Deciphered Date	2011/03/18	Title	
THIS SHEET OF ENGINEERING DRAWING IS THE PROPRIETARY PROPERTY OF COMPAL ELECTRONICS, INC. AND CONTAINS CONFIDENTIAL AND TRADE SECRET INFORMATION. THIS SHEET MAY NOT BE TRANSFERRED FROM THE CUSTODY OF THE COMPETENT DIVISION OF R&D DEPARTMENT EXCEPT AS AUTHORIZED BY COMPAL ELECTRONICS, INC. NEITHER THIS SHEET NOR THE INFORMATION IT CONTAINS MAY BE USED BY OR DISCLOSED TO ANY THIRD PARTY WITHOUT PRIOR WRITTEN CONSENT OF COMPAL ELECTRONICS, INC.				Mini-Card/BT CONN	
Size	Document Number	LA-6501P		Rev	0.2
Date:	Friday, May 07, 2010	E	Sheet	14	of 35

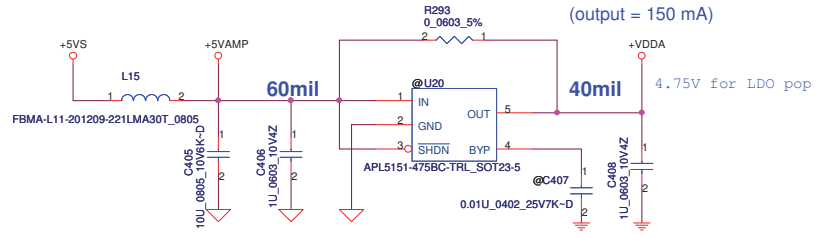
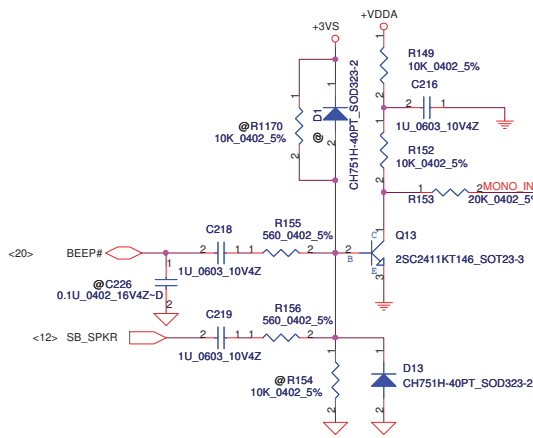

### HD Audio Codec

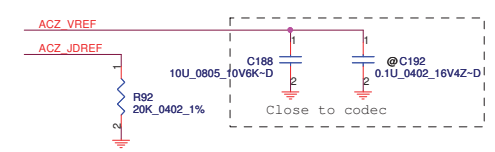
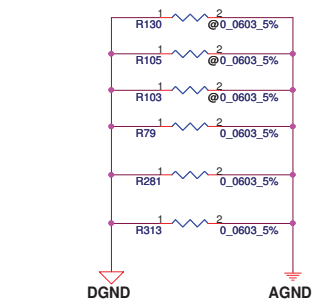
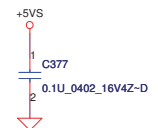
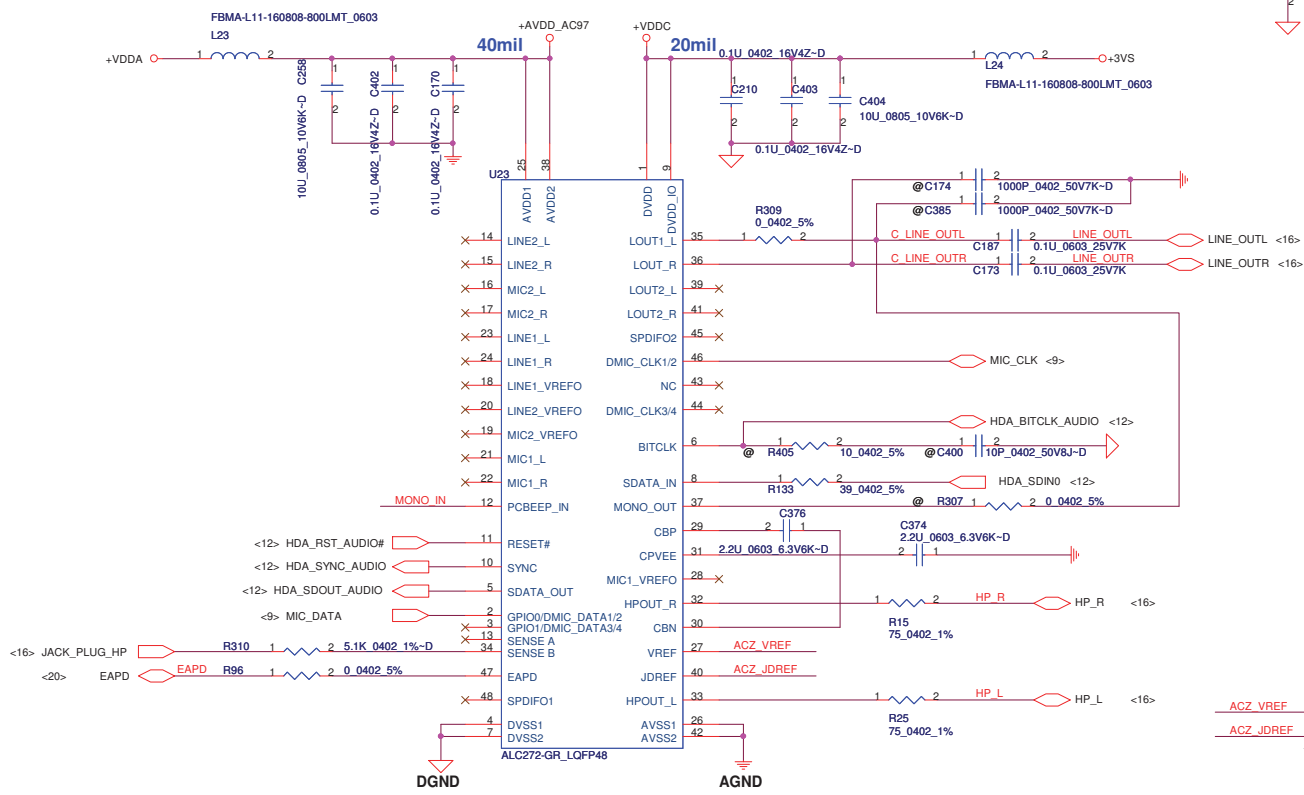

Security Classification	Compal Secret Data	
Issued Date	2010/03/18	Deciphered Date
		2011/03/18

THIS SHEET OF ENGINEERING DRAWING IS THE PROPRIETARY PROPERTY OF COMPAL ELECTRONICS, INC. AND CONTAINS CONFIDENTIAL AND TRADE SECRET INFORMATION. THIS SHEET MAY NOT BE TRANSFERRED FROM THE CUSTODY OF THE COMPETENT DIVISION OF R&D DEPARTMENT EXCEPT AS AUTHORIZED BY COMPAL ELECTRONICS, INC. NEITHER THIS SHEET NOR THE INFORMATION IT CONTAINS MAY BE USED BY OR DISCLOSED TO ANY THIRD PARTY WITHOUT PRIOR WRITTEN CONSENT OF COMPAL ELECTRONICS, INC.

Compal Electronics, Inc.		
Title		
ALC272-GR Codec		
Size	Document Number	Rev
Custom	LA-6501P	0.2
Date:	Friday, May 07, 2010	E Sheet 15 of 35

GAIN0	GAIN1	
0	0	6dB
0	1	10dB
1	0	15.6dB *
1	1	21.6dB

### APA2031A SPK Amplifier

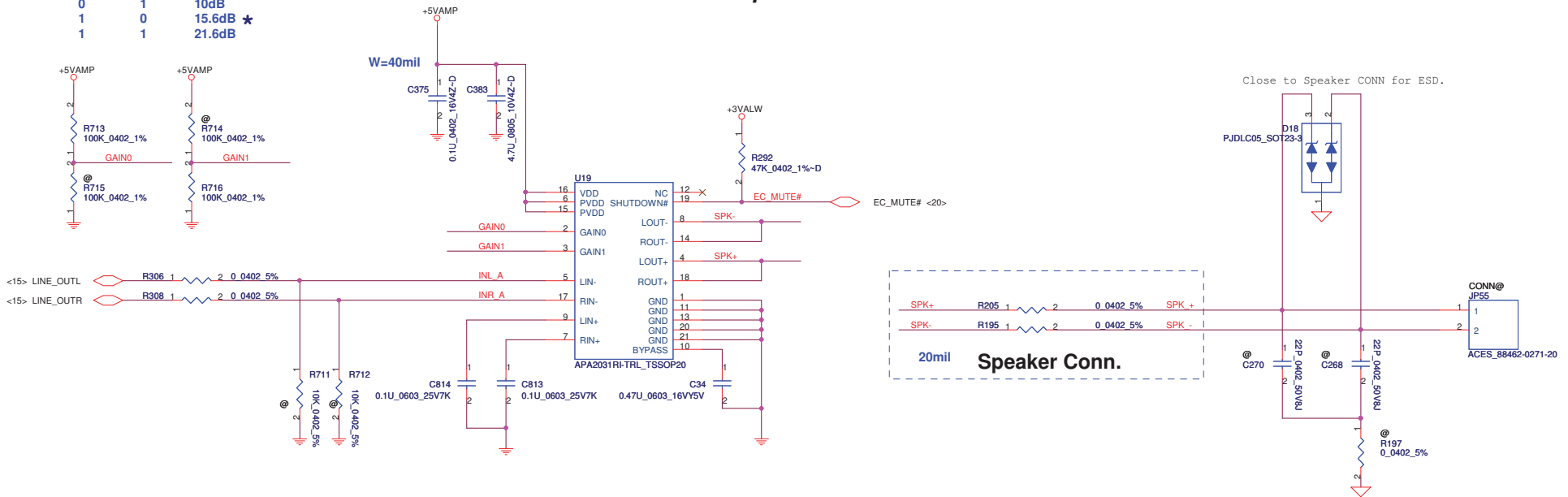

### HeadPhone JACK

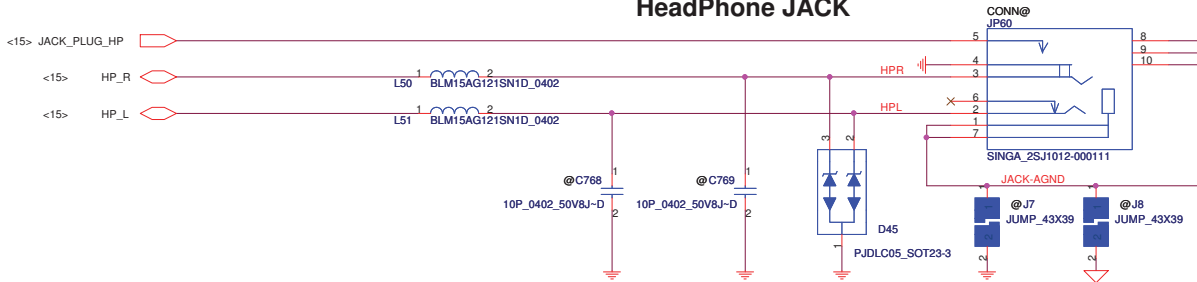

Security Classification	Compal Secret Data	
Issued Date	2010/03/18	Deciphered Date
		2011/03/18

THIS SHEET OF ENGINEERING DRAWING IS THE PROPRIETARY PROPERTY OF COMPAL ELECTRONICS, INC. AND CONTAINS CONFIDENTIAL AND TRADE SECRET INFORMATION. THIS SHEET MAY NOT BE TRANSFERRED FROM THE CUSTODY OF THE COMPETENT DIVISION OF R&D DEPARTMENT EXCEPT AS AUTHORIZED BY COMPAL ELECTRONICS, INC. NEITHER THIS SHEET NOR THE INFORMATION IT CONTAINS MAY BE USED BY OR DISCLOSED TO ANY THIRD PARTY WITHOUT PRIOR WRITTEN CONSENT OF COMPAL ELECTRONICS, INC.

Compal Electronics, Inc.			
Title			
Speaker/Audio Jack			
Size	Document Number	Rev	
Custom	LA-6501P	0.2	
Date:	Monday, May 10, 2010	Sheet	16 of 35



### For SATA HDD

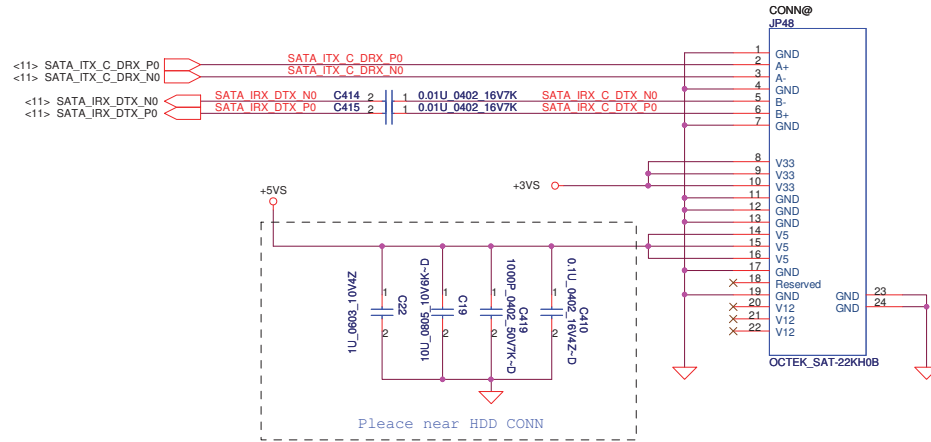

### POWER LED

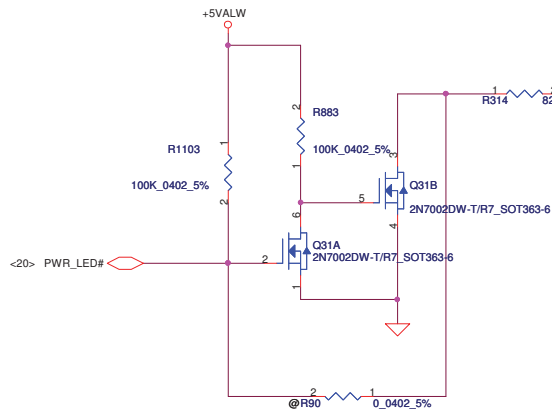

### BATT CHARGE LED

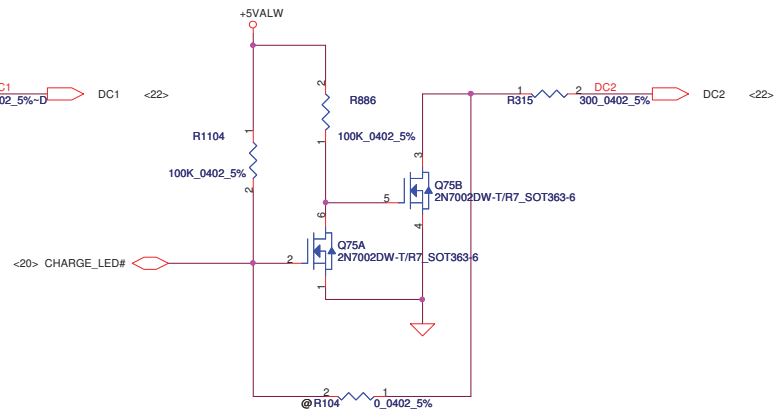

Security Classification	Compal Secret Data			Compal Electronics, Inc.		
Issued Date	2010/03/18	Deciphered Date	2011/03/18	Title		
				SATA/LED		
THIS SHEET OF ENGINEERING DRAWING IS THE PROPRIETARY PROPERTY OF COMPAL ELECTRONICS, INC. AND CONTAINS CONFIDENTIAL AND TRADE SECRET INFORMATION. THIS SHEET MAY NOT BE TRANSFERRED FROM THE CUSTODY OF THE COMPETENT DIVISION OF R&D DEPARTMENT EXCEPT AS AUTHORIZED BY COMPAL ELECTRONICS, INC. NEITHER THIS SHEET NOR THE INFORMATION IT CONTAINS MAY BE USED BY OR DISCLOSED TO ANY THIRD PARTY WITHOUT PRIOR WRITTEN CONSENT OF COMPAL ELECTRONICS, INC.				Size	Document Number	Rev
				Custom	LA-6501P	0.2
				Date:	Monday, May 10, 2010	Sheet 17 of 35

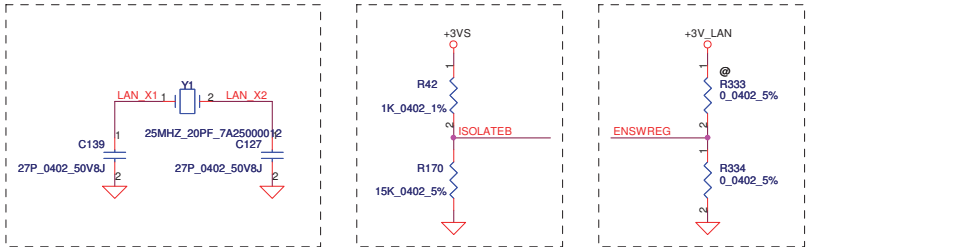
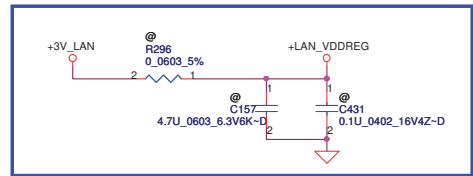
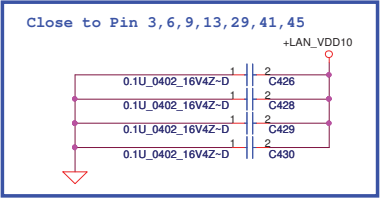
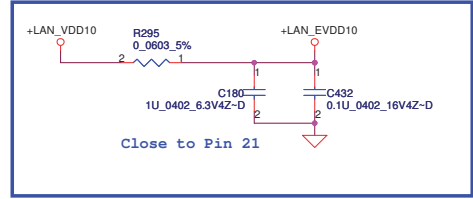
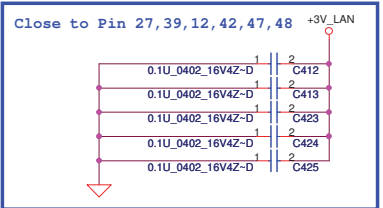
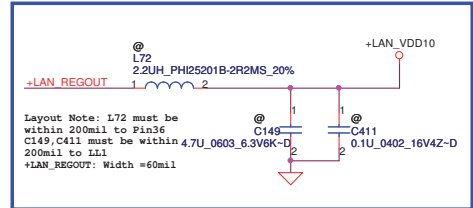
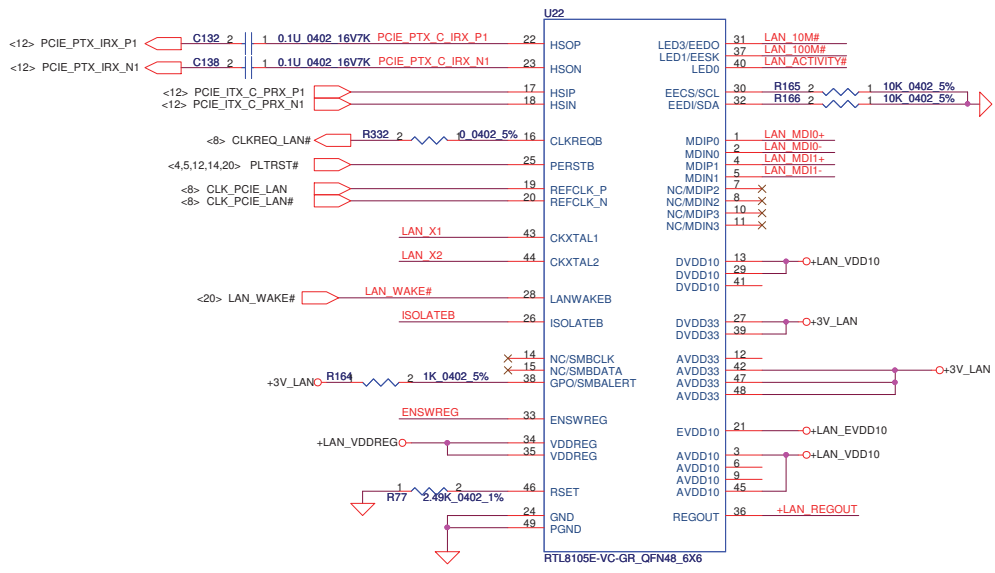

RJ45 symbol need update

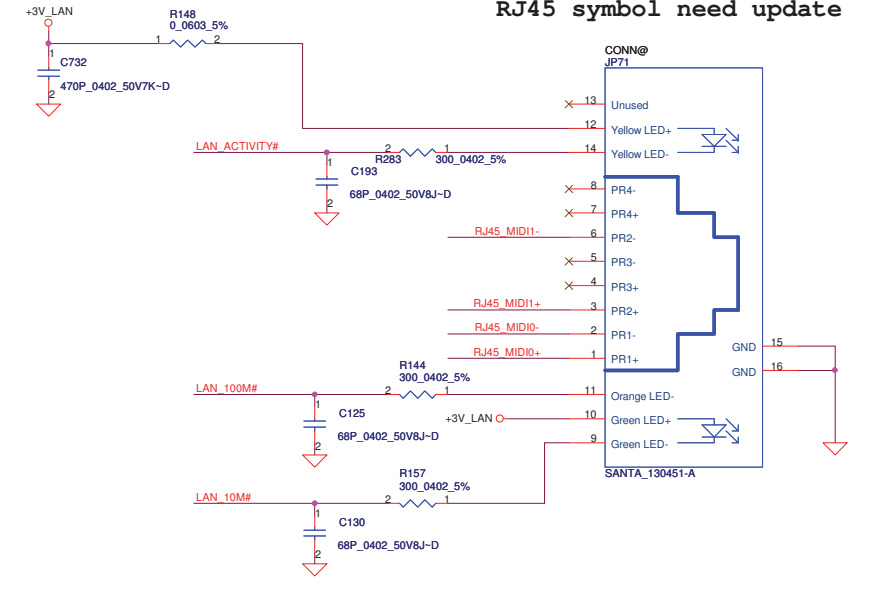
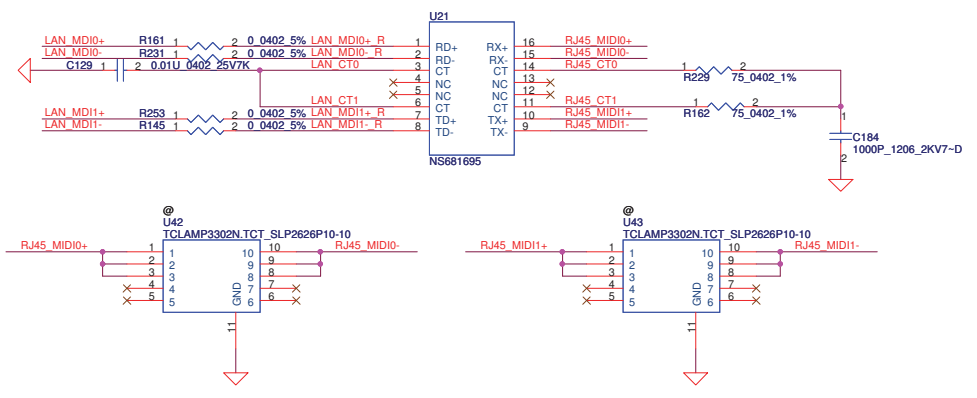

Security Classification	Compal Secret Data		Title	
Issued Date	2010/03/18	Deciphered Date	2011/03/18	RTL8105E-VC-GR
THIS SHEET OF ENGINEERING DRAWING IS THE PROPRIETARY PROPERTY OF COMPAL ELECTRONICS, INC. AND CONTAINS CONFIDENTIAL AND TRADE SECRET INFORMATION. THIS SHEET MAY NOT BE TRANSFERRED FROM THE CUSTODY OF THE COMPETENT DIVISION OF R&D DEPARTMENT EXCEPT AS AUTHORIZED BY COMPAL ELECTRONICS, INC. NEITHER THIS SHEET NOR THE INFORMATION IT CONTAINS MAY BE USED BY OR DISCLOSED TO ANY THIRD PARTY WITHOUT PRIOR WRITTEN CONSENT OF COMPAL ELECTRONICS, INC.				
Size	Document Number	Date	Monday, May 10, 2010	Rev 0.2
Custom	LA-6501P	Sheet	18	of 35

# 3 in 1 Card Reader

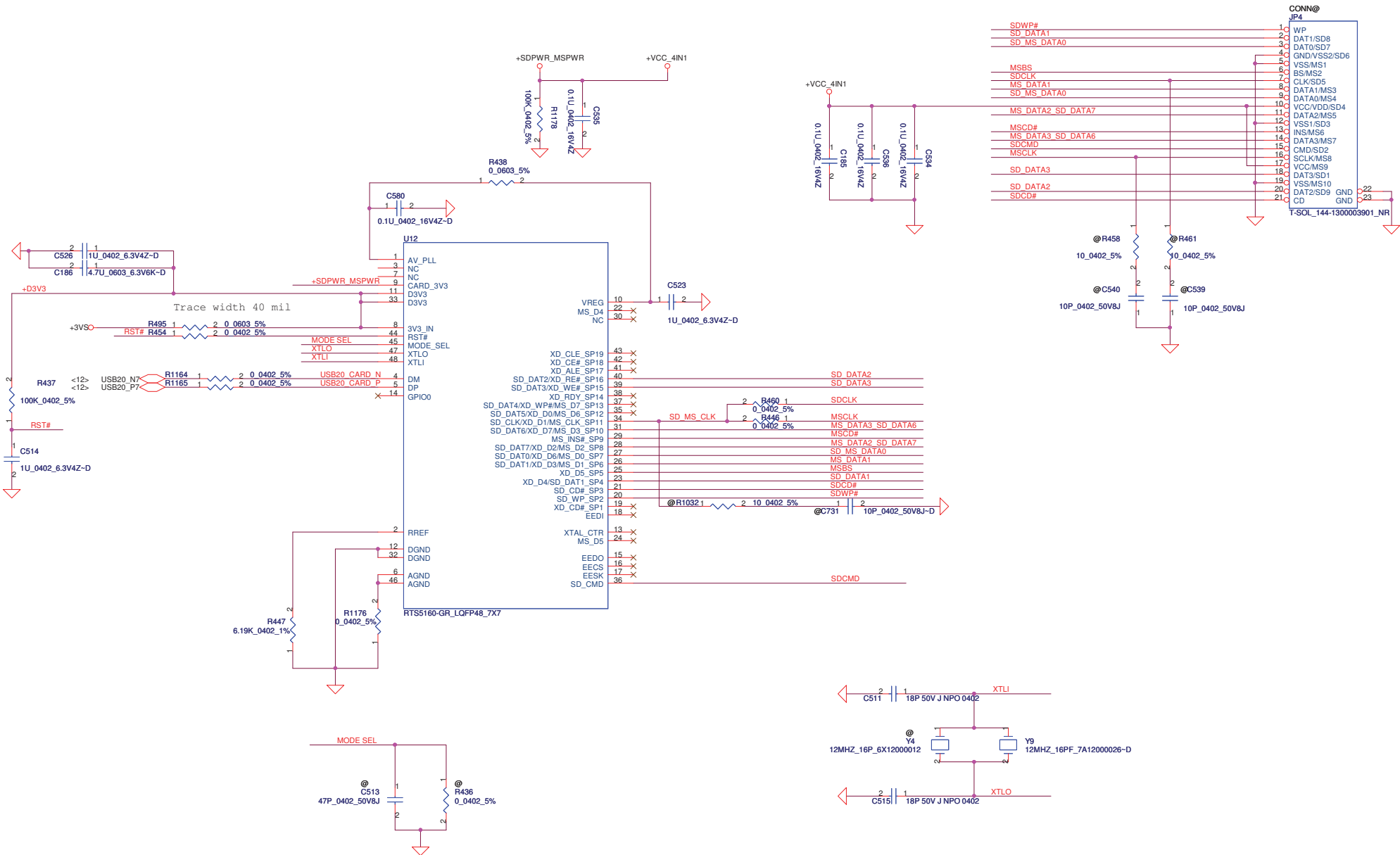

Security Classification		Compal Secret Data		Compal Electronics, Inc.	
Issued Date	2010/03/18	Deciphered Date	2011/03/18	Title	Carder RTS5160
THIS SHEET OF ENGINEERING DRAWING IS THE PROPRIETARY PROPERTY OF COMPAL ELECTRONICS, INC. AND CONTAINS CONFIDENTIAL AND TRADE SECRET INFORMATION. THIS SHEET MAY NOT BE TRANSFERRED FROM THE CUSTODY OF THE COMPETENT DIVISION OF R&D DEPARTMENT EXCEPT AS AUTHORIZED BY COMPAL ELECTRONICS, INC. NEITHER THIS SHEET NOR THE INFORMATION IT CONTAINS MAY BE USED BY OR DISCLOSED TO ANY THIRD PARTY WITHOUT PRIOR WRITTEN CONSENT OF COMPAL ELECTRONICS, INC.					
Size	Document Number	Rev			
Custom	LA-6501P	0.2			
Date:	Monday, May 10, 2010	Sheet	19	of	35

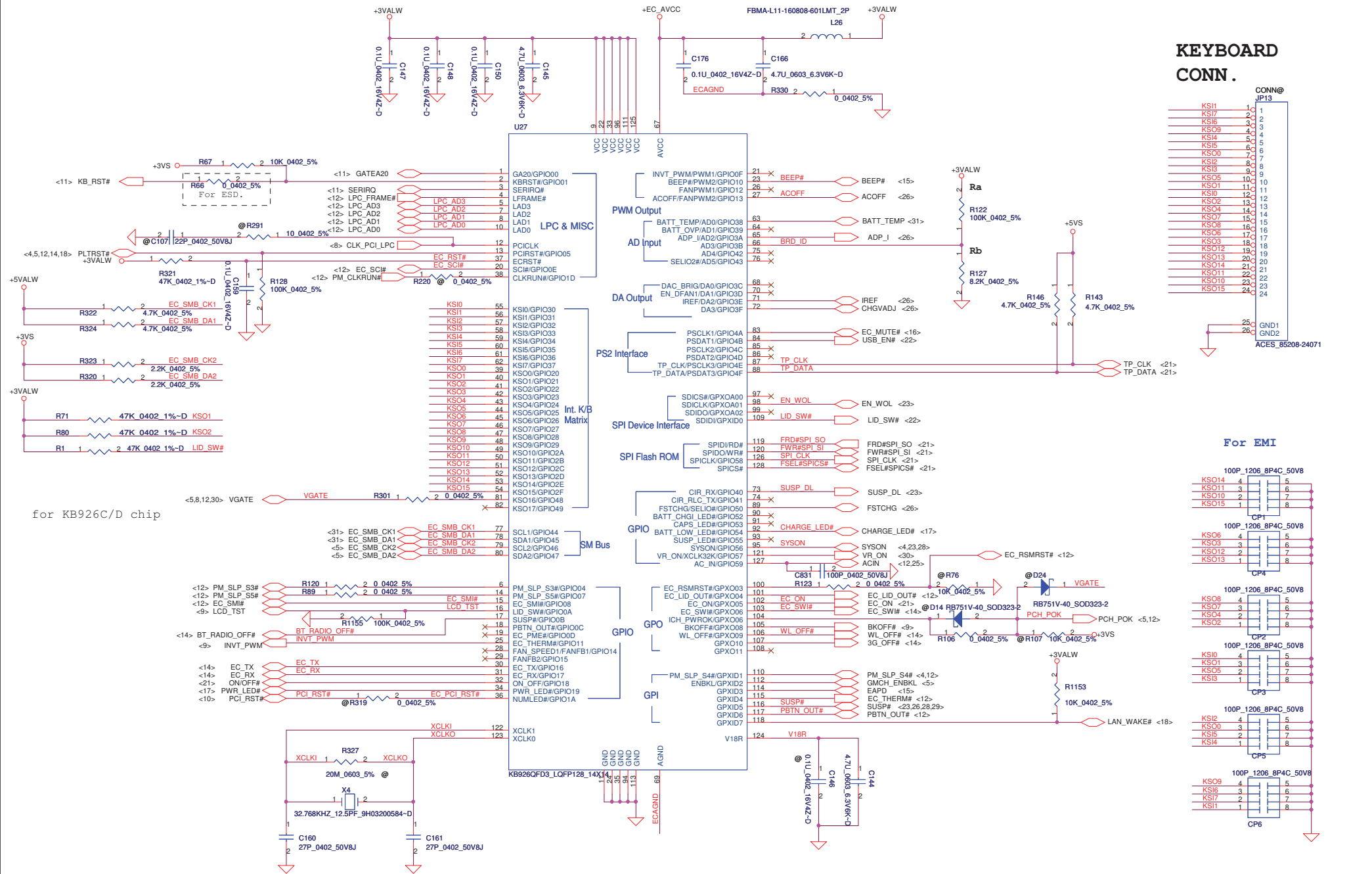

for KB926C/D chip

### KEYBOARD CONN.

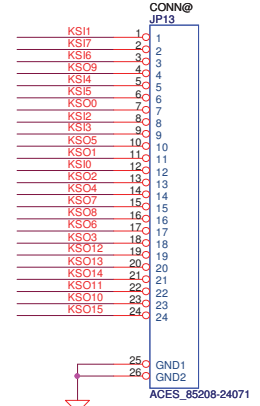

### For EMI

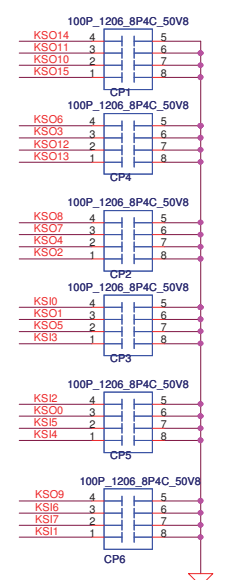

Security Classification	Compal Secret Data		Compal Electronics, Inc.	
Issued Date	2010/03/18	Deciphered Date	2011/03/18	Title
THIS SHEET OF ENGINEERING DRAWING IS THE PROPRIETARY PROPERTY OF COMPAL ELECTRONICS, INC. AND CONTAINS CONFIDENTIAL AND TRADE SECRET INFORMATION. THIS SHEET MAY NOT BE TRANSFERRED FROM THE CUSTODY OF THE COMPETENT DIVISION OF R&D DEPARTMENT EXCEPT AS AUTHORIZED BY COMPAL ELECTRONICS, INC. NEITHER THIS SHEET NOR THE INFORMATION IT CONTAINS MAY BE USED BY OR DISCLOSED TO ANY THIRD PARTY WITHOUT PRIOR WRITTEN CONSENT OF COMPAL ELECTRONICS, INC.				KB926-E0
Size	Document Number	Rev		
Custart	LA-6501P	0.2		
Date	Friday, May 07, 2010	Sheet	20	of 35

### Touch/B Connector

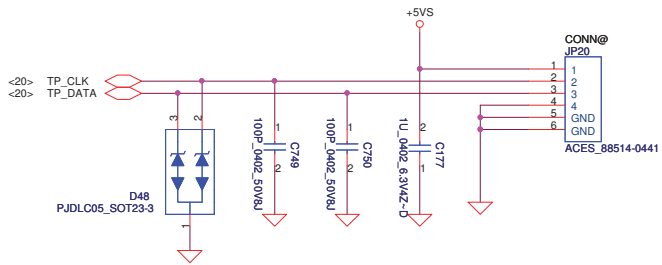

### System SPI Flash ROM (16Mb)

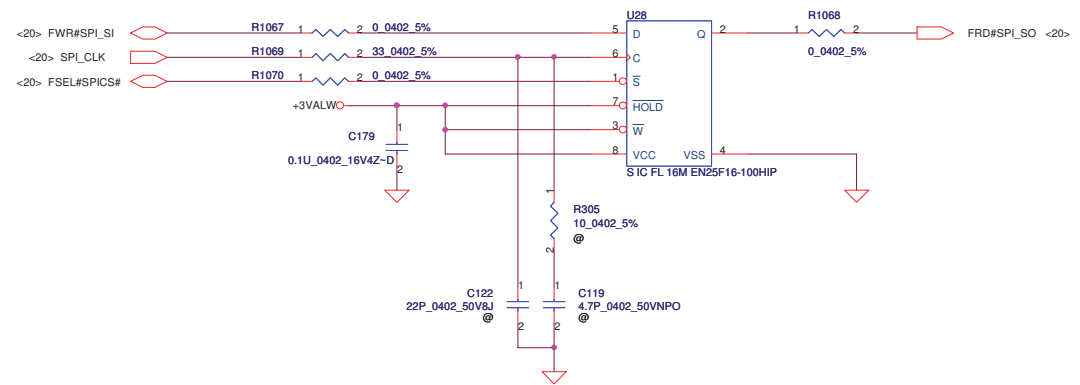

### MB\_Power On/Off SW

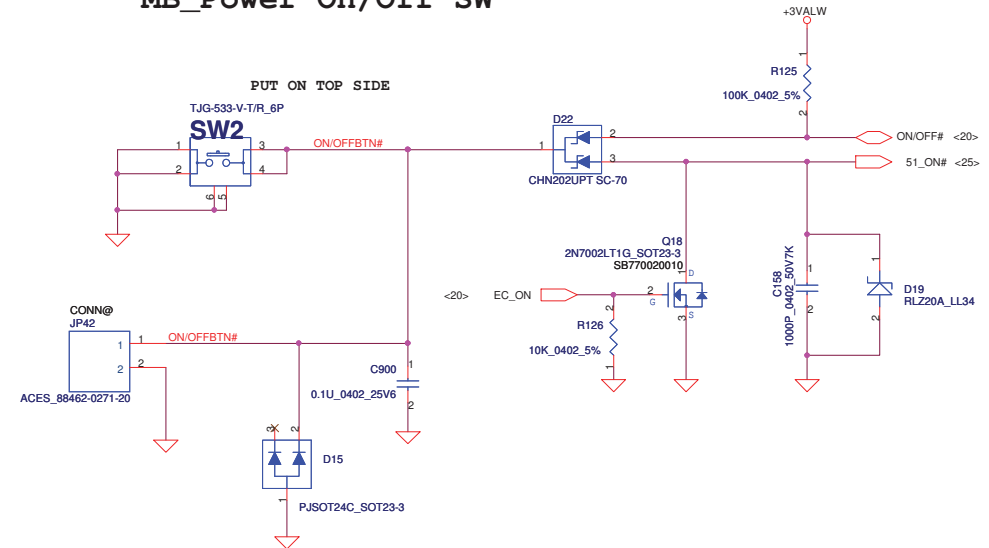

Security Classification		Compal Secret Data		Compal Electronics, Inc.	
Issued Date	2010/03/18	Deciphered Date	2011/03/18	Title	
THIS SHEET OF ENGINEERING DRAWING IS THE PROPRIETARY PROPERTY OF COMPAL ELECTRONICS, INC. AND CONTAINS CONFIDENTIAL AND TRADE SECRET INFORMATION. THIS SHEET MAY NOT BE TRANSFERRED FROM THE CUSTODY OF THE COMPETENT DIVISION OF R&D DEPARTMENT EXCEPT AS AUTHORIZED BY COMPAL ELECTRONICS, INC. NEITHER THIS SHEET NOR THE INFORMATION IT CONTAINS MAY BE USED BY OR DISCLOSED TO ANY THIRD PARTY WITHOUT PRIOR WRITTEN CONSENT OF COMPAL ELECTRONICS, INC.				BIOS/TP	
Size	Custom	Document Number	LA-6501P	Rev	0.2
Date:	Monday, May 10, 2010	Sheet	21	of	35

# On Board USB Connector

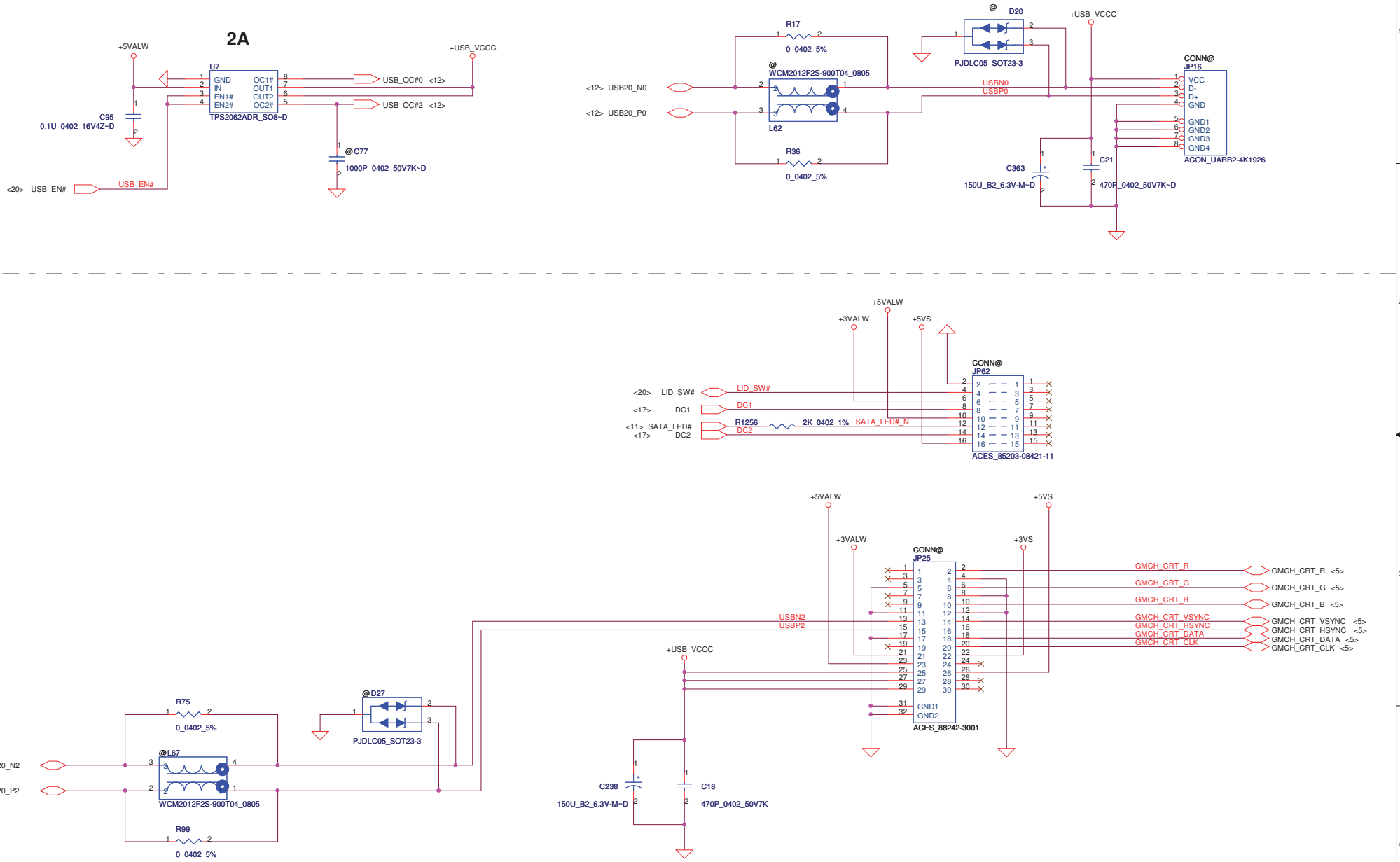

Security Classification		Compal Secret Data		Compal Electronics, Inc.	
Issued Date	2010/03/18	Deciphered Date	2011/03/18	Title	
				USB PORTS/DB CN	
THIS SHEET OF ENGINEERING DRAWING IS THE PROPRIETARY PROPERTY OF COMPAL ELECTRONICS, INC. AND CONTAINS CONFIDENTIAL AND TRADE SECRET INFORMATION. THIS SHEET MAY NOT BE TRANSFERRED FROM THE CUSTODY OF THE COMPETENT DIVISION OF R&D DEPARTMENT EXCEPT AS AUTHORIZED BY COMPAL ELECTRONICS, INC. NEITHER THIS SHEET NOR THE INFORMATION IT CONTAINS MAY BE USED BY OR DISCLOSED TO ANY THIRD PARTY WITHOUT PRIOR WRITTEN CONSENT OF COMPAL ELECTRONICS, INC.		Size	Document Number	Rev	
		Custom	LA-6501P	0.2	
Date:	Friday, May 07, 2010	Sheet	22	of	35

**+5VALW TO +5VS**

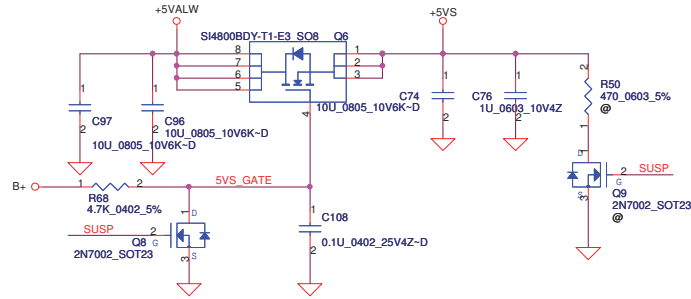

**+3VALW TO +3VS**

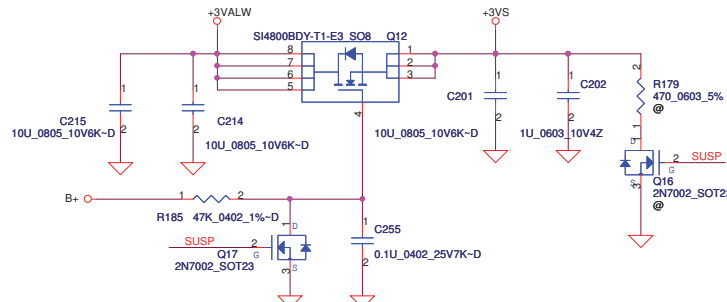

**+3VALW to +3V\_LAN**

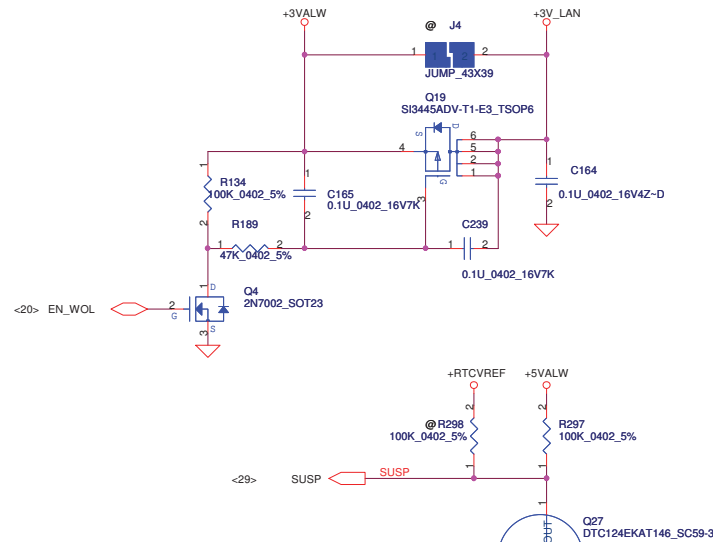

If the +1.5V discharge circuit is pop, R302, Q28 need pop.

**+1.5V to +1.5VS Transfer**

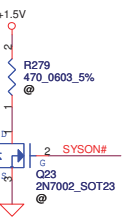
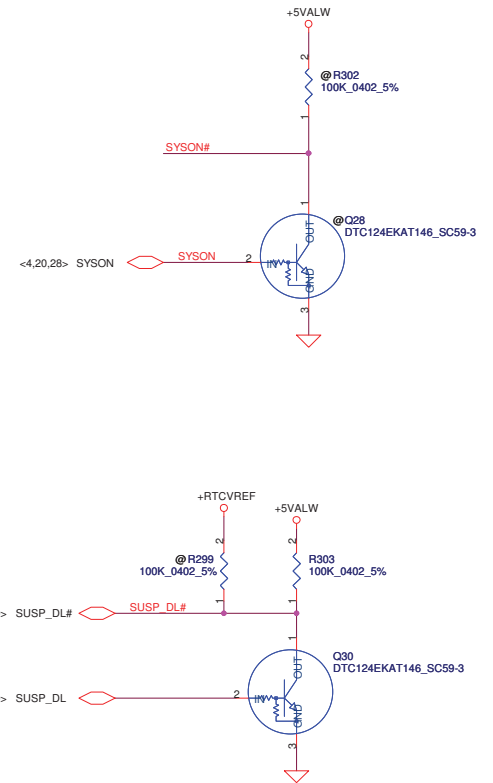
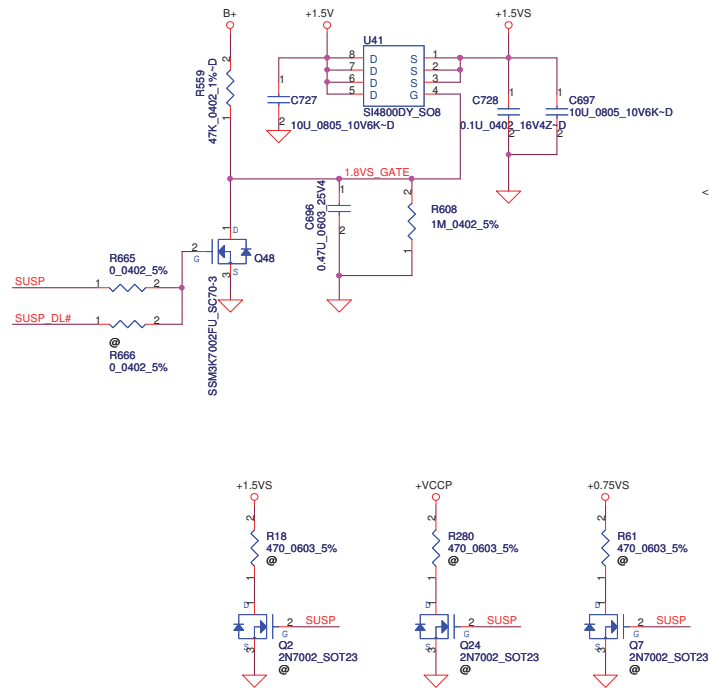

Security Classification	Compal Secret Data		Compal Electronics, Inc.	
Issued Date	2010/03/18	Deciphered Date	2011/03/18	Title
THIS SHEET OF ENGINEERING DRAWING IS THE PROPRIETARY PROPERTY OF COMPAL ELECTRONICS, INC. AND CONTAINS CONFIDENTIAL AND TRADE SECRET INFORMATION. THIS SHEET MAY NOT BE TRANSFERRED FROM THE CUSTODY OF THE COMPETENT DIVISION OF R&D DEPARTMENT EXCEPT AS AUTHORIZED BY COMPAL ELECTRONICS, INC. NEITHER THIS SHEET NOR THE INFORMATION IT CONTAINS MAY BE USED BY OR DISCLOSED TO ANY THIRD PARTY WITHOUT PRIOR WRITTEN CONSENT OF COMPAL ELECTRONICS, INC.				DC INTERFACE
Size	Document Number	Rev		
	LA-6501P	0.2		
Date:	Friday, May 07, 2010	Sheet	23	of 35

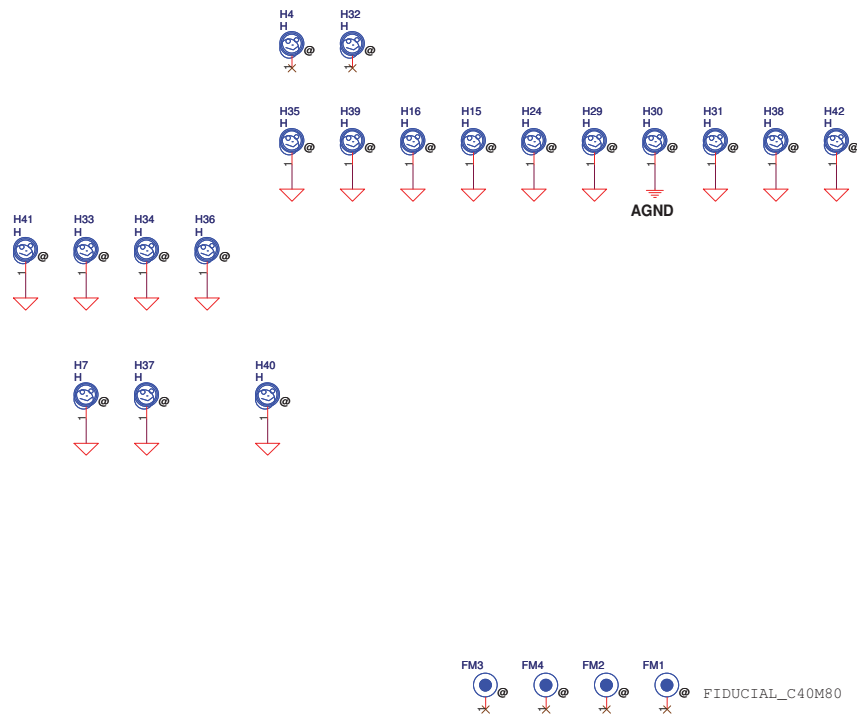

Security Classification	Compal Secret Data		Title	
Issued Date	2010/03/18	Deciphered Date	2011/03/18	
THIS SHEET OF ENGINEERING DRAWING IS THE PROPRIETARY PROPERTY OF COMPAL ELECTRONICS, INC. AND CONTAINS CONFIDENTIAL AND TRADE SECRET INFORMATION. THIS SHEET MAY NOT BE TRANSFERRED FROM THE CUSTODY OF THE COMPETENT DIVISION OF R&D DEPARTMENT EXCEPT AS AUTHORIZED BY COMPAL ELECTRONICS, INC. NEITHER THIS SHEET NOR THE INFORMATION IT CONTAINS MAY BE USED OR DISCLOSED TO ANY THIRD PARTY WITHOUT PRIOR WRITTEN CONSENT OF COMPAL ELECTRONICS, INC.			Size	Rev
			Document Number	0.2
			Custom	LA-6501P
			Date:	Tuesday, April 27, 2010
			Sheet	24 of 35

Compal Electronics, Inc.

Screw

LA-6501P



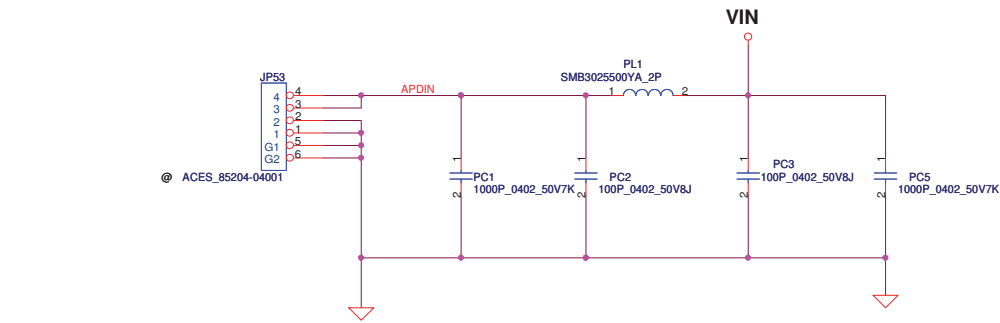

Vin Detector		
High	17.944	17.706
Low	16.242	16.027
	15.808	

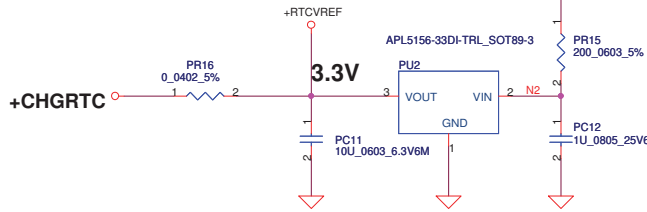
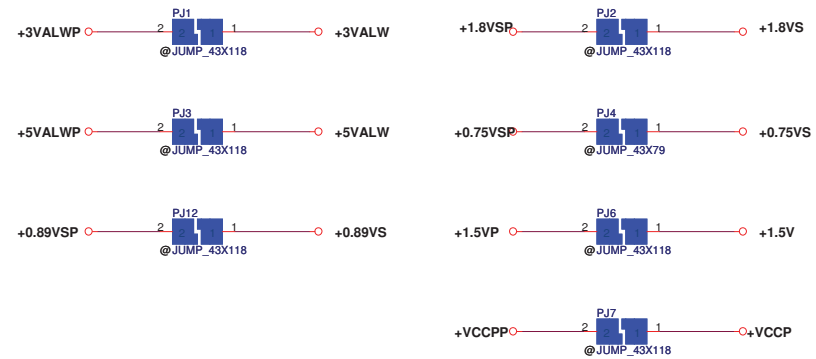
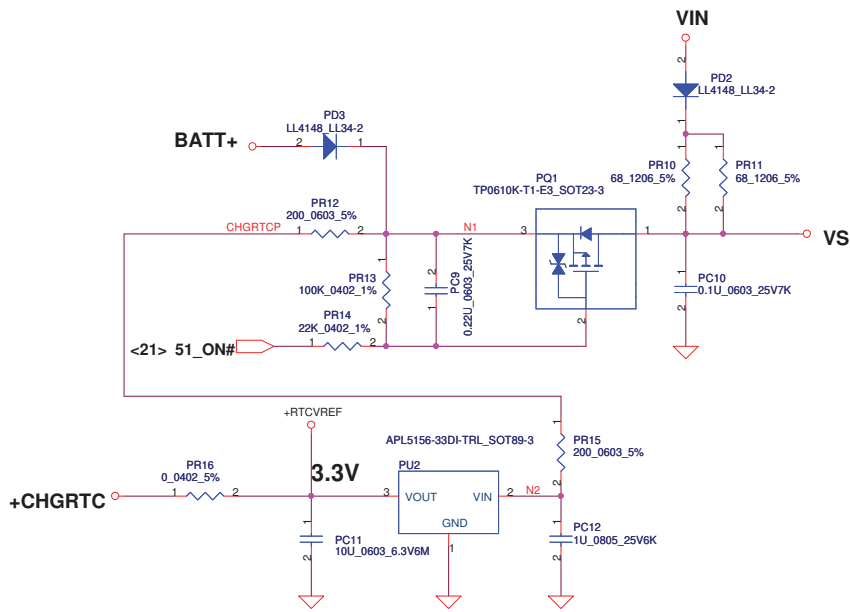
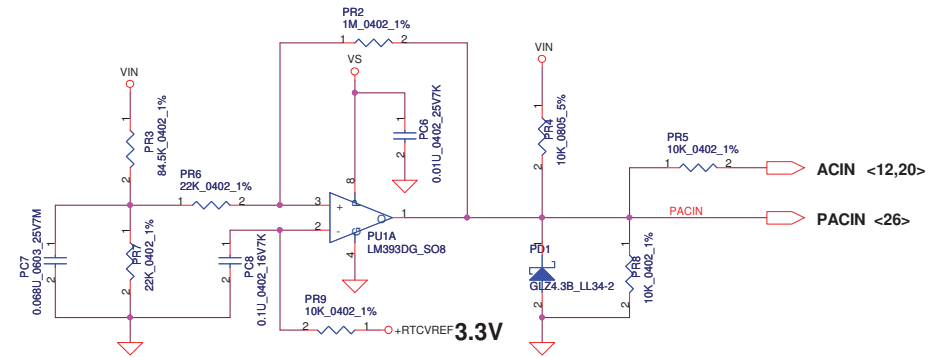

Security Classification	Compal Secret Data		Compal Electronics, Inc.	
Issued Date	2010/03/18	Deciphered Date	2011/03/18	Title
THIS SHEET OF ENGINEERING DRAWING IS THE PROPRIETARY PROPERTY OF COMPAL ELECTRONICS, INC. AND CONTAINS CONFIDENTIAL AND TRADE SECRET INFORMATION. THIS SHEET MAY NOT BE TRANSFERRED FROM THE CUSTODY OF THE COMPETENT DIVISION OF R&D DEPARTMENT EXCEPT AS AUTHORIZED BY COMPAL ELECTRONICS, INC. NEITHER THIS SHEET NOR THE INFORMATION IT CONTAINS MAY BE USED BY OR DISCLOSED TO ANY THIRD PARTY WITHOUT PRIOR WRITTEN CONSENT OF COMPAL ELECTRONICS, INC.				DCIN/DECTOR
Size	Document Number	Rev	0.2	
Date:	Friday, May 07, 2010	Sheet	25	of 35

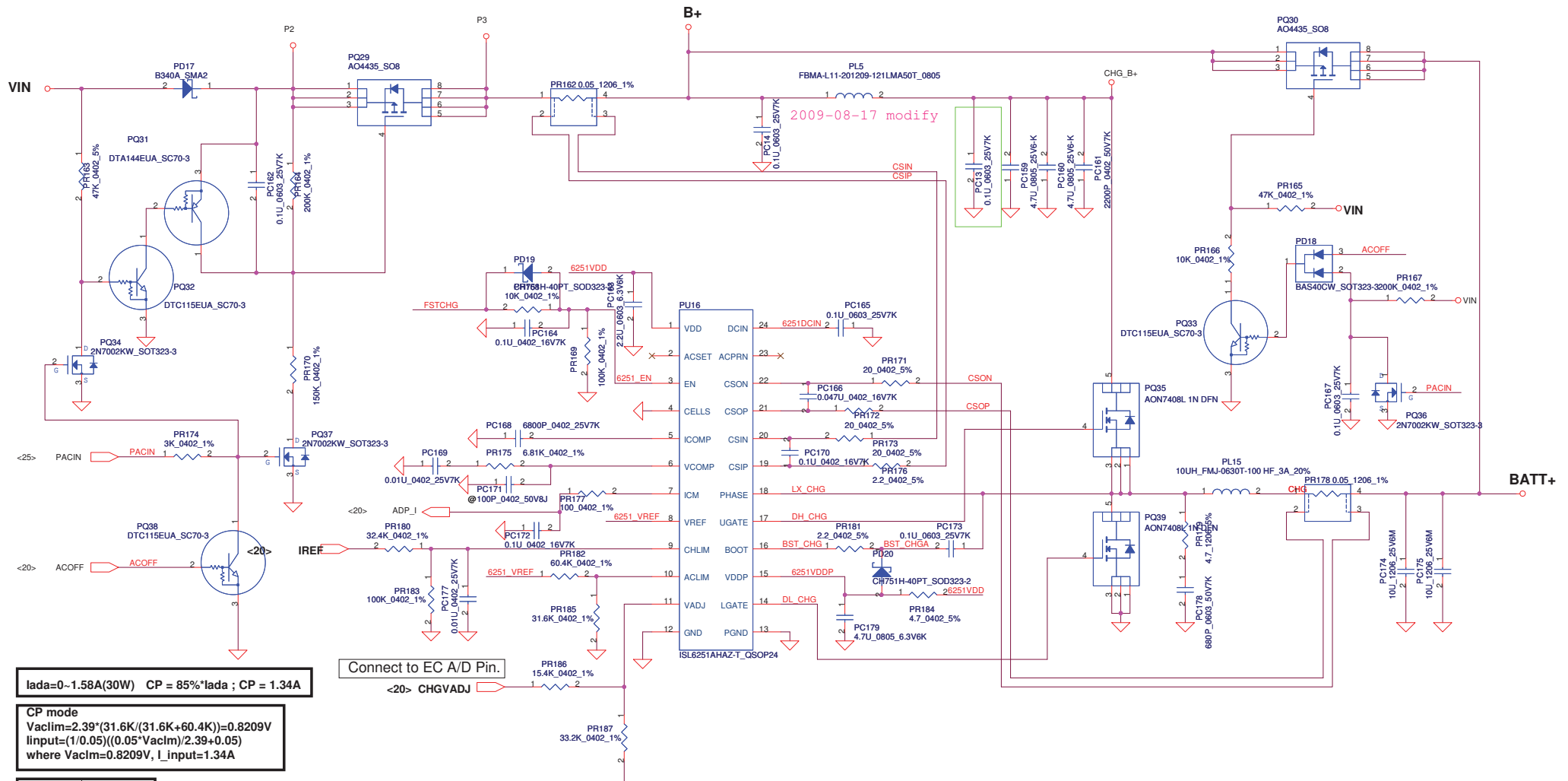

$I_{ada} = 0 \sim 1.58A(30W)$   $CP = 85\% \cdot I_{ada}$ ;  $CP = 1.34A$

CP mode  
 $V_{acim} = 2.39 \cdot (31.6K / (31.6K + 60.4K)) = 0.8209V$   
 $I_{input} = (1/0.05) \cdot ((0.05 \cdot V_{acim}) / 2.39 + 0.05)$   
 where  $V_{acim} = 0.8209V$ ,  $I_{input} = 1.34A$

IREF	Current
2.58V	1.9A

Connect to EC A/D Pin.

Pre Cell	CHGVADJ
4V	0V
4.35V	3.3V

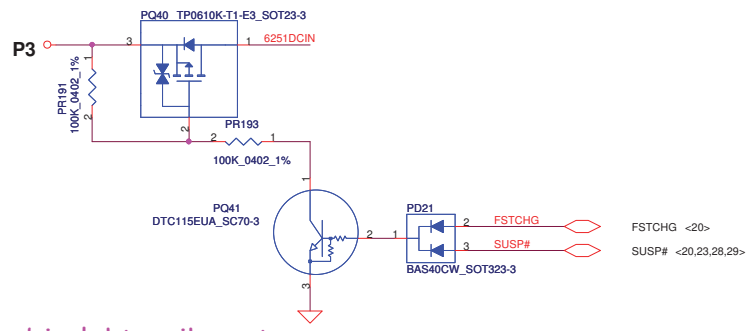

Security Classification	Compal Secret Data	
Issued Date	2010/03/18	Deciphered Date
		2011/03/18

THIS SHEET OF ENGINEERING DRAWING IS THE PROPRIETARY PROPERTY OF COMPAL ELECTRONICS, INC. AND CONTAINS CONFIDENTIAL AND TRADE SECRET INFORMATION. THIS SHEET MAY NOT BE TRANSFERRED FROM THE CUSTODY OF THE COMPETENT DIVISION OF R&D DEPARTMENT EXCEPT AS AUTHORIZED BY COMPAL ELECTRONICS, INC. NEITHER THIS SHEET NOR THE INFORMATION IT CONTAINS MAY BE USED BY OR DISCLOSED TO ANY THIRD PARTY WITHOUT PRIOR WRITTEN CONSENT OF COMPAL ELECTRONICS, INC.

Compal Electronics, Inc.		
<b>CHARGER</b>		
Title	Document Number	Rev
		0.2
Date: Friday, May 07, 2010	Sheet	26 of 35

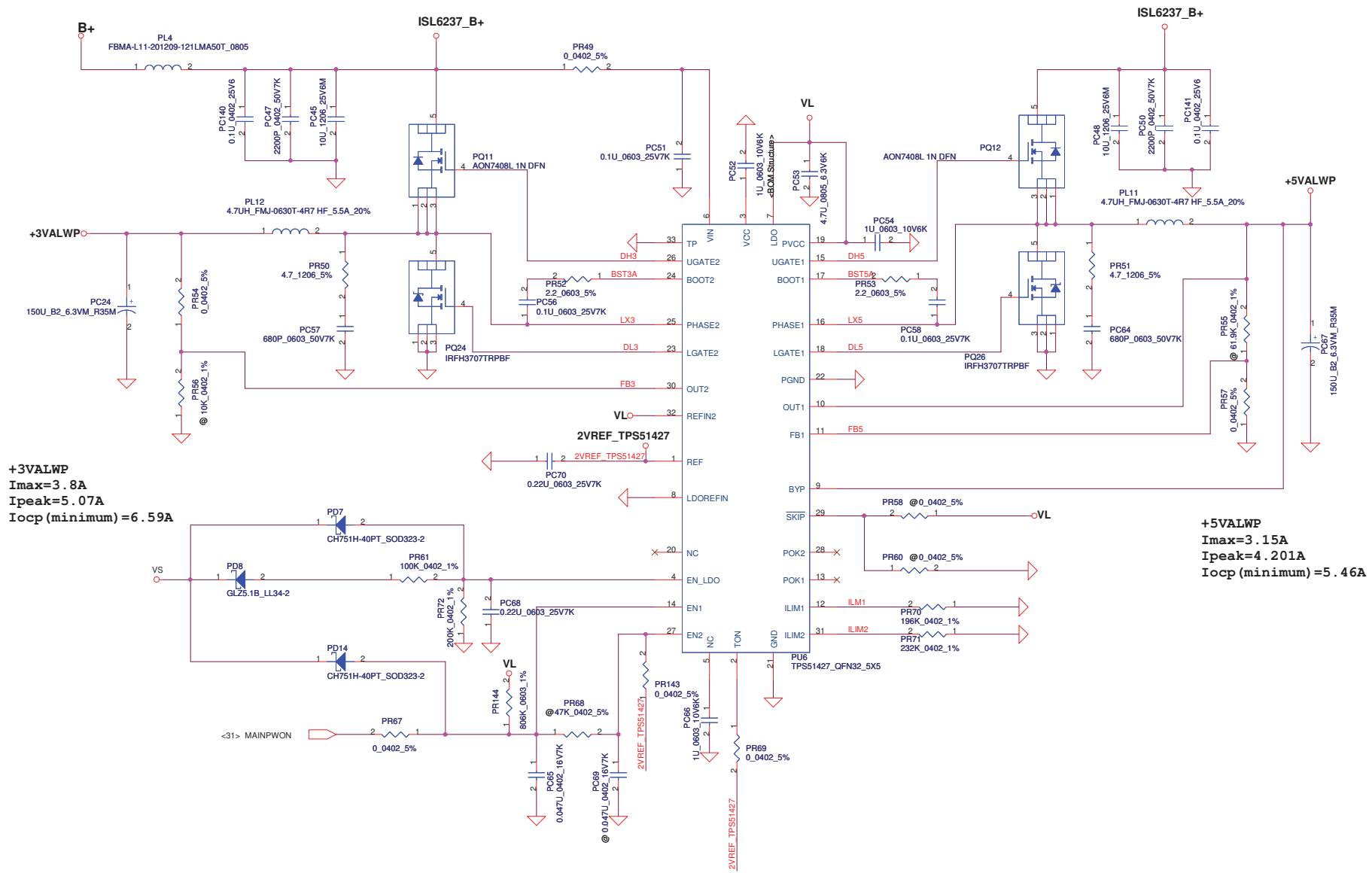

**+3VALWP**  
 $I_{max} = 3.8A$   
 $I_{peak} = 5.07A$   
 $I_{ocp} (minimum) = 6.59A$

**+5VALWP**  
 $I_{max} = 3.15A$   
 $I_{peak} = 4.201A$   
 $I_{ocp} (minimum) = 5.46A$

Security Classification	Compal Secret Data		Compal Electronics, Inc.	
Issued Date	2010/03/18	Deciphered Date	2011/03/18	Title
THIS SHEET OF ENGINEERING DRAWING IS THE PROPRIETARY PROPERTY OF COMPAL ELECTRONICS, INC. AND CONTAINS CONFIDENTIAL AND TRADE SECRET INFORMATION. THIS SHEET MAY NOT BE TRANSFERRED FROM THE CUSTODY OF THE COMPETENT DIVISION OF R&D DEPARTMENT EXCEPT AS AUTHORIZED BY COMPAL ELECTRONICS, INC. NEITHER THIS SHEET NOR THE INFORMATION IT CONTAINS MAY BE USED BY OR DISCLOSED TO ANY THIRD PARTY WITHOUT PRIOR WRITTEN CONSENT OF COMPAL ELECTRONICS, INC.				3VALW/5VALW
Size	Document Number	Rev	0.2	
Custom				
Date:	Friday, May 07, 2010	Sheet	27	of 35

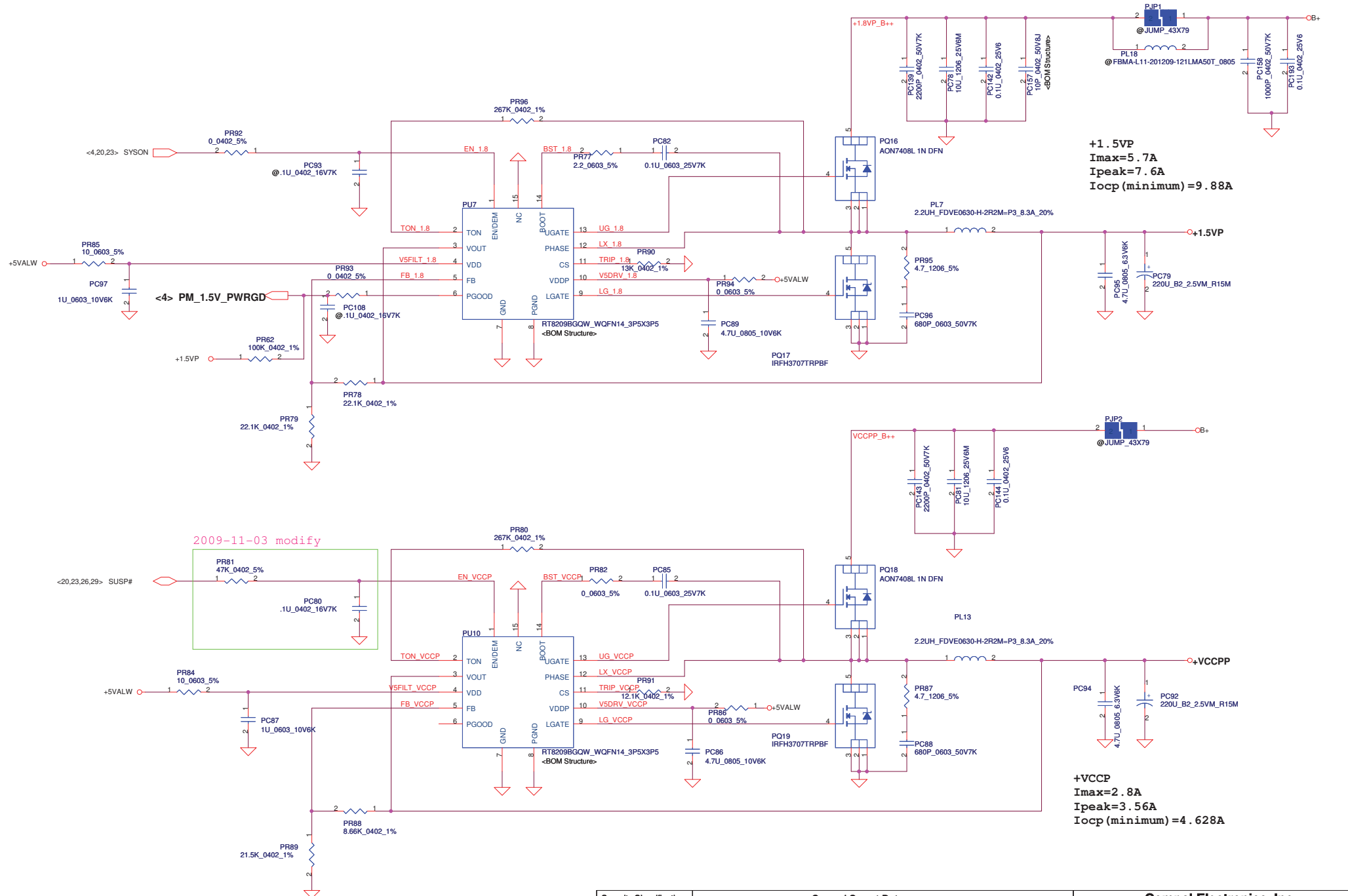

2009-11-03 modify

Security Classification	Compal Secret Data			Compal Electronics, Inc.		
Issued Date	2010/03/18	Deciphered Date	2011/03/18	Title		
				1.5V/VCCPP		
THIS SHEET OF ENGINEERING DRAWING IS THE PROPRIETARY PROPERTY OF COMPAL ELECTRONICS, INC. AND CONTAINS CONFIDENTIAL AND TRADE SECRET INFORMATION. THIS SHEET MAY NOT BE TRANSFERRED FROM THE CUSTODY OF THE COMPETENT DIVISION OF R&D DEPARTMENT EXCEPT AS AUTHORIZED BY COMPAL ELECTRONICS, INC. NEITHER THIS SHEET NOR THE INFORMATION IT CONTAINS MAY BE USED BY OR DISCLOSED TO ANY THIRD PARTY WITHOUT PRIOR WRITTEN CONSENT OF COMPAL ELECTRONICS, INC.				Size	Document Number	Rev
				Custom		0.2
				Date:	Friday, May 07, 2010	Sheet 28 of 35

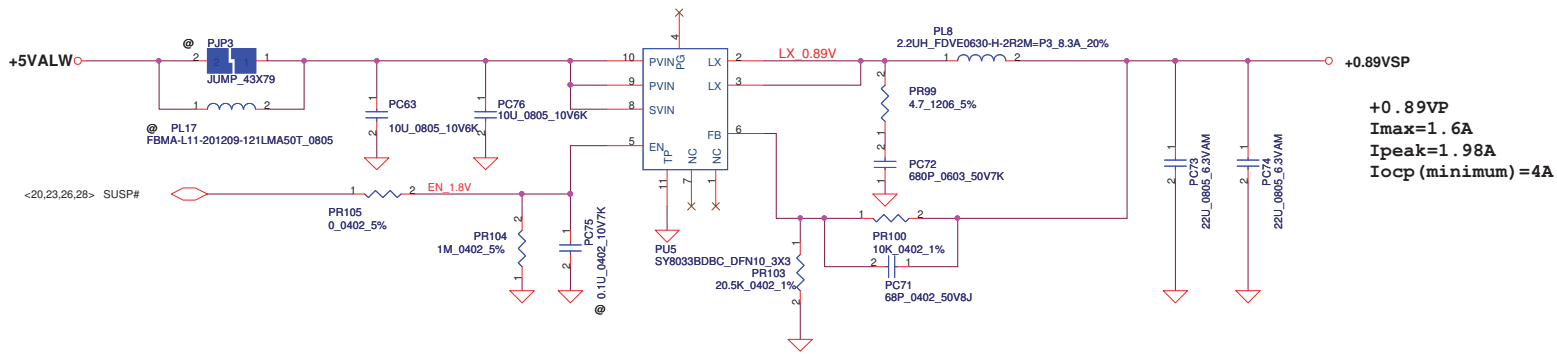

**+0.89VSP**  
**Imax=1.6A**  
**Ipeak=1.98A**  
**Iocp (minimum)=4A**

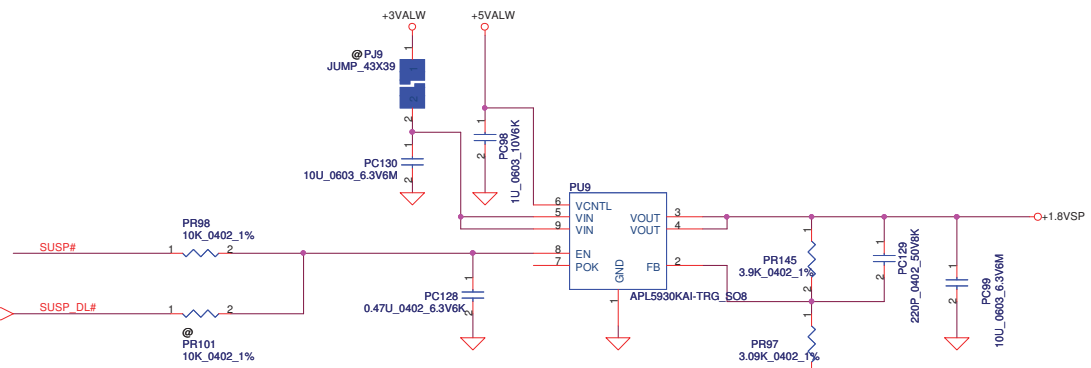
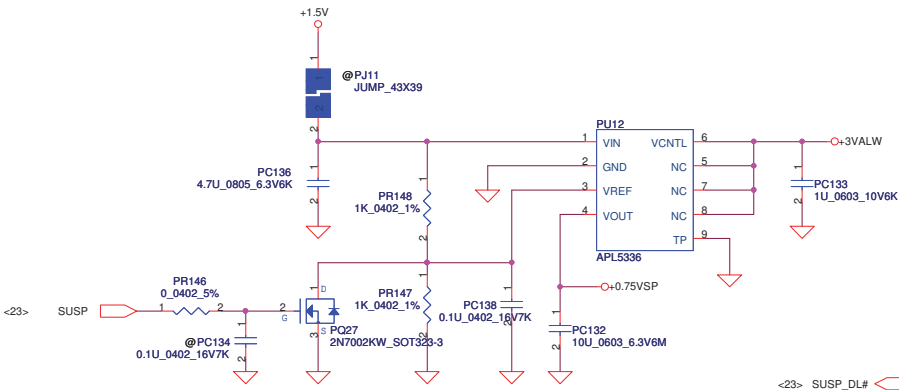

Security Classification	Compal Secret Data			Compal Electronics, Inc.		
Issued Date	2010/03/18	Deciphered Date	2011/03/18	Title		
				1.8VS/0.9VS/0.89VS/1.2VS		
THIS SHEET OF ENGINEERING DRAWING IS THE PROPRIETARY PROPERTY OF COMPAL ELECTRONICS, INC. AND CONTAINS CONFIDENTIAL AND TRADE SECRET INFORMATION. THIS SHEET MAY NOT BE TRANSFERRED FROM THE CUSTODY OF THE COMPETENT DIVISION OF R&D DEPARTMENT EXCEPT AS AUTHORIZED BY COMPAL ELECTRONICS, INC. NEITHER THIS SHEET NOR THE INFORMATION IT CONTAINS MAY BE USED BY OR DISCLOSED TO ANY THIRD PARTY WITHOUT PRIOR WRITTEN CONSENT OF COMPAL ELECTRONICS, INC.				Size Custom	Document Number	Rev 0.2
Date:	Monday, May 10, 2010	Sheet	29	of 35		

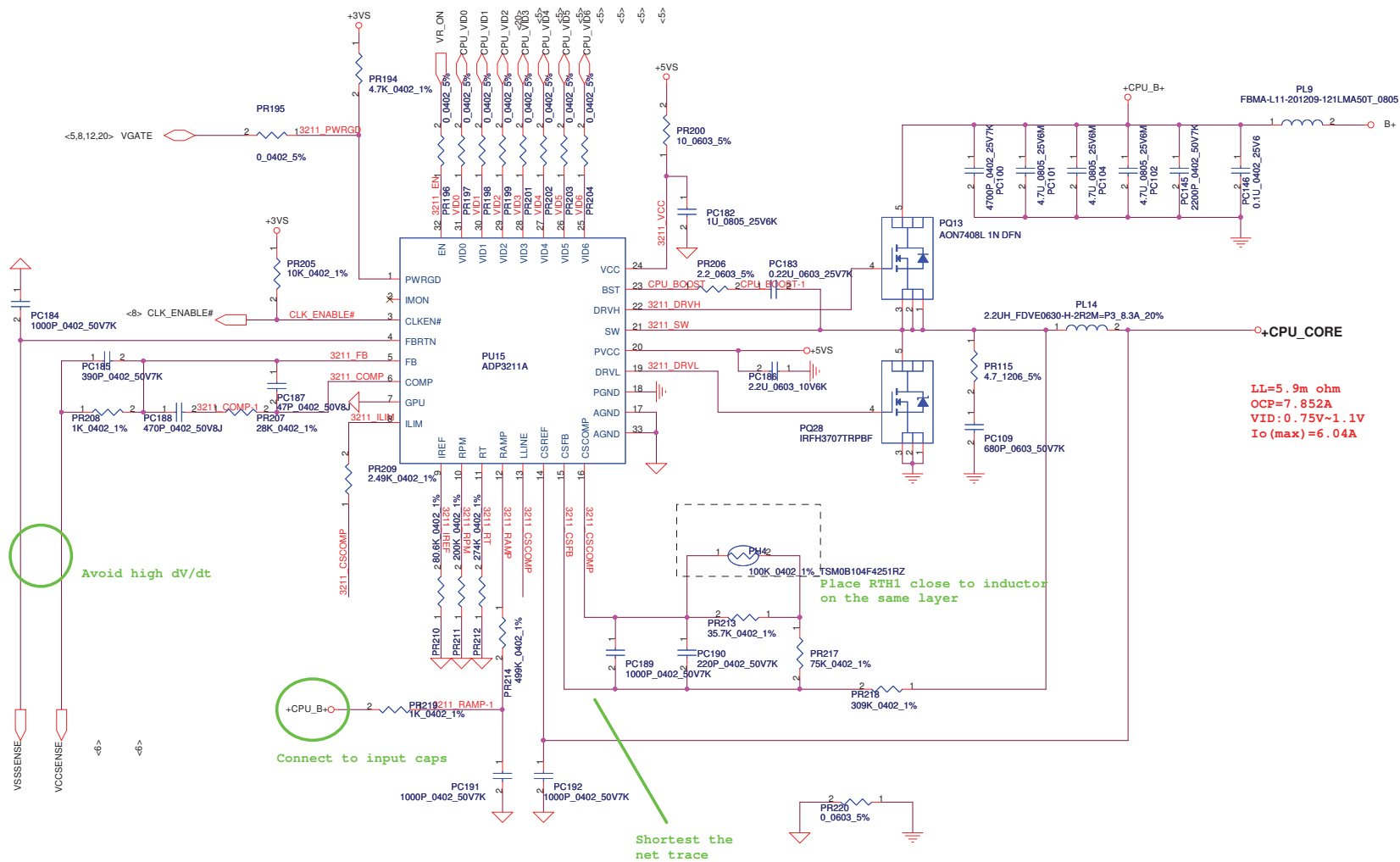

LL=5.9m ohm  
 OCP=7.852A  
 VID: 0.75V~1.1V  
 Io (max)=6.04A

Security Classification	Compal Secret Data		Compal Electronics, Inc.	
Issued Date	2010/03/18	Deciphered Date	2011/03/18	Title
THIS SHEET OF ENGINEERING DRAWING IS THE PROPRIETARY PROPERTY OF COMPAL ELECTRONICS, INC. AND CONTAINS CONFIDENTIAL AND TRADE SECRET INFORMATION. THIS SHEET MAY NOT BE TRANSFERRED FROM THE CUSTODY OF THE COMPETENT DIVISION OF R&D DEPARTMENT EXCEPT AS AUTHORIZED BY COMPAL ELECTRONICS, INC. NEITHER THIS SHEET NOR THE INFORMATION IT CONTAINS MAY BE USED BY OR DISCLOSED TO ANY THIRD PARTY WITHOUT PRIOR WRITTEN CONSENT OF COMPAL ELECTRONICS, INC.				CPU CORE Rev 0.2
Size	Document Number	Sheet	30	of
Custom		Friday, May 07, 2010	02	35

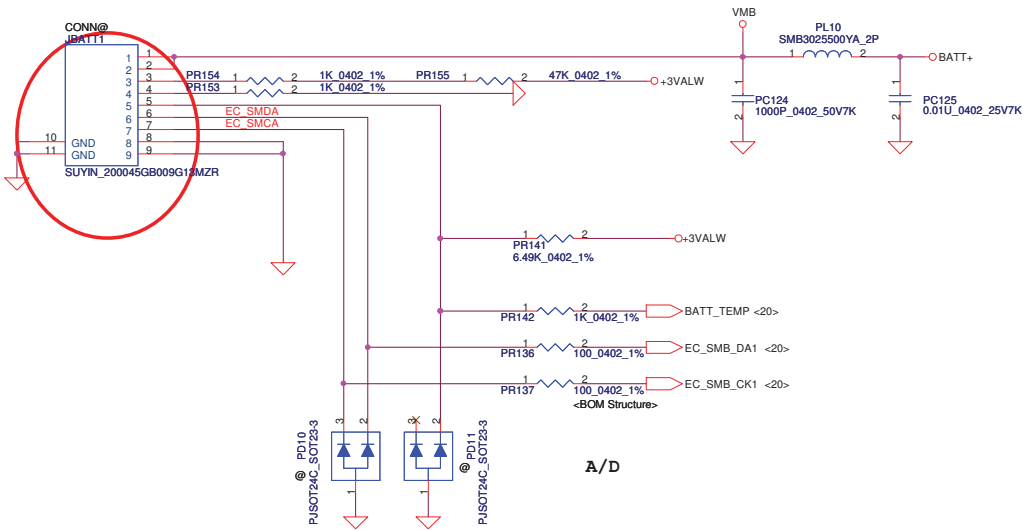

PH3 under CPU botten side :  
 CPU thermal protection at 90 degree C  
 Recovery at 50 degree C

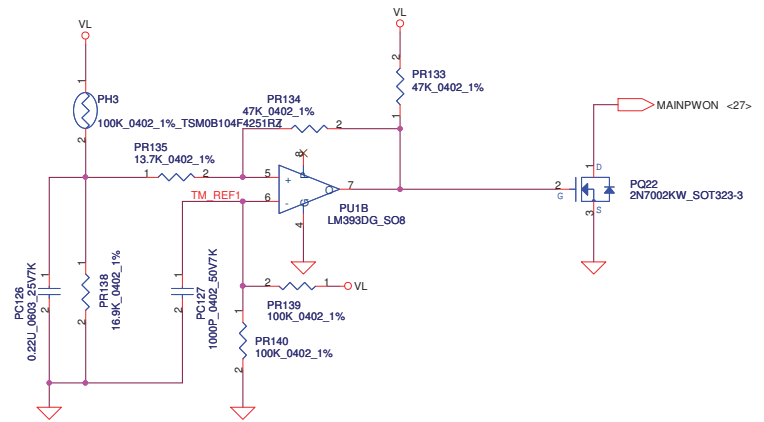

A/D

Security Classification		Compal Secret Data		Compal Electronics, Inc.		
Issued Date	2010/03/18	Deciphered Date	2011/03/18	Title		
				BATTERY CONN/OTP		
THIS SHEET OF ENGINEERING DRAWING IS THE PROPRIETARY PROPERTY OF COMPAL ELECTRONICS, INC. AND CONTAINS CONFIDENTIAL AND TRADE SECRET INFORMATION. THIS SHEET MAY NOT BE TRANSFERRED FROM THE CUSTODY OF THE COMPETENT DIVISION OF R&D DEPARTMENT EXCEPT AS AUTHORIZED BY COMPAL ELECTRONICS, INC. NEITHER THIS SHEET NOR THE INFORMATION IT CONTAINS MAY BE USED BY OR DISCLOSED TO ANY THIRD PARTY WITHOUT PRIOR WRITTEN CONSENT OF COMPAL ELECTRONICS, INC.				Size Custom	Document Number	Rev 0.2
				Date:	Friday, May 07, 2010	Sheet 31 of 35

Version change list (P.I.R. List)

Item	Reason for change	Rev.	PG#	Modify List	Date	Phase
1	Reserve bead to prevent noise issue happen		P27, P28	Reserve PL16, PL17, PL18	2009.07.24	PT
2	EMI request add snubber to reduce power board band.		P26, P27 P28, P29	Change PR77, PR206 to 2.2_0603_5%. Add PR87, PR95, PR50, PR51, PR115 4.7_1206_5% into BOM. Add PC88, PC96, PC57, PC64, PC109 680P_0603_50V. Add PC157 10P_0402_50V	2009.08.05	PT
3	Reserve 0.89V LDO soultion		P28	Reserve PU11, PC131, PC103, PC155, PC154, PC105 PR99, PR157, PR100	2009.08.05	PT
4	Adjust the +1.5VSP LDO feedback		P28	Change PC129 to 220P 25V K NPO 0402	2009.08.05	PT
5	For reduce trace space.		P30	Change JBATT1 pin3 & pin5 from +3VALWP to +3VALW.	2009.09.17	ST
6	Adjust the VCORE OCP		P30	Change PR209 to 2.49K_0402_1%	2009.09.17	ST
7	Adjust the +0.89VSP OCP		P28	Change PR160 to 5.9K_0402_1%	2009.09.17	ST
8	EMI request add snubber to reduce power board band.		P25, P28 P27	Add PR161, PR179 4.7_1206_5%. Add PC151, PC178 680P_0603_50V7K. Add PC13, PC14, PC193 0.1u_0603_25V Add PC158 1000p_0402_50v	2009.09.21	ST
9						
10						

Security Classification		Compal Secret Data		Compal Electronics, Inc.		
Issued Date	2010/03/18	Deciphered Date	2011/03/18	Title		
<small>THIS SHEET OF ENGINEERING DRAWING IS THE PROPRIETARY PROPERTY OF COMPAL ELECTRONICS, INC. AND CONTAINS CONFIDENTIAL AND TRADE SECRET INFORMATION. THIS SHEET MAY NOT BE TRANSFERRED FROM THE CUSTODY OF THE COMPETENT DIVISION OF R&amp;D DEPARTMENT EXCEPT AS AUTHORIZED BY COMPAL ELECTRONICS, INC. NEITHER THIS SHEET NOR THE INFORMATION IT CONTAINS MAY BE USED BY OR DISCLOSED TO ANY THIRD PARTY WITHOUT PRIOR WRITTEN CONSENT OF COMPAL ELECTRONICS, INC.</small>				Size Custom	Document Number	Rev 0.2
Date:				Tuesday, April 27, 2010	Sheet	32 of 35



Item	Date	Fixed Issue	Rev.	PG#	Modify List
01	2009/12/08	Flea chip on board	0.1	P.15	Add U42,U43 and U44
02	2009/12/08	Flea chip on board	0.1	P.14	Remove jp57,C401,C411,C409,C412,C135
03	2009/12/08	for FAN circuit	0.1	P.20 P.21	Add U3,JP14,C10,C427,C420,C418,C417,R47,R307,D6,D9;Connect U27 pin28 to JP14 pin2.
04	2009/12/09	7Beeps hang on ICH7 platform	0.1	P.08	Add R150
05	2009/12/09	BCM BT + WLAN combo	0.1	P.14	Remove jp22, C185, C186,R2,R116
06	2009/12/09	for thermal solution	0.1	P.14	Add U3, C10, C427,R2,JP14,D6,D9,C420,C418,R307,C417
07	2009/12/28	for standard pin define for PCIE MINI Card	0.1	P.14	Connect JP56 pin 6, 28, 48 to +1.5VS, reserve C123,C120,C114,C910.
08	2010/01/06	for DDRIII SODIMM design	0.1	P.4	U31 pin AL28,AJ26 pull high to +1.5V;Add C1102,C256;Connect U31 pin AB4 to PU7 pin 6.
09	2010/01/07	for Intel CRB schematic Rev.0.5	0.1	P.6	Change C928,C929,C930,C931 from 2.2uF to 1uF;Add C273 22uF;Change C379 from 0.1uF to 1uF.
10	2010/01/14	for ICS Low Power CLK Gen. Co-lay circuit	0.1	P.8	U11 pin62 pull high to +1.5VS / +1.05VS.
11	2010/01/14	for touch screen function	0.1	P.9 P.12	Connect JP24 pin 34,36 from USB20_P6/N6 to USB20_P5/N5;Pop R1168 and R1169.
12	2010/01/14	for +1.5VS transfer circuit	0.1	P.23	Connect U41 pin 5,6,7,8 to +1.5V;pin 1,2 to +1.5VS
13	2010/01/14	Change crystal package size	0.1	P.8,12, 19,20	Co-lay Y8 and Y5,change Y1,Y6,Y4 to small size package.
14	2010/01/19	for Intel checklist Rev. 2.0	0.1	P.6	Reserve C401,C409 close to U31.AA19,de-pop C925
15	2010/01/19	for Intel CRB DRAM POWEROK circuit	0.1	P.4	Add U45,R158,R142,R294,R93,R136,R1188,C78,C178
16	2010/01/21	for POWER concern to Delete BATT_OVP circuit	0.1	P.20	Disconnect U27.64
17	2010/01/27	for WLAN+BT module card design	0.1	P.14	Add R159,R160 close to JP54 pin5 and pin20.
18	2010/01/28	for EC team concern	0.1	P.14	Add R74 close to JP54 pin49.
19	2010/01/29	for Broadcom check request	0.1	P.15	Connect U42 pin D11 directly to GND.
20	2010/01/29	for Broadcom check request	0.1	P.15	Add test points on U42 pin M8 and M9.
21	2010/01/29	for Broadcom check request	0.1	P.15	Change L68,L69 to TDK MMZ2012R601AT.
22	2010/01/29	for Broadcom check request	0.1	P.15	Change C1082 and C1083 from 15pF to 18pF;change Y7 from 7M27100019 to 7M27070004.
23	2010/02/04	for power sequence	0.1	P.04	Connect U45 pin5 to SYSON.
24	2010/02/26	for RF concern	0.1	P.08	Pop C832 and C392.
25	2010/02/26	for Power sequence	0.1	P.23 P.29	Change C696 from 0.01uF to 0.47uF;Pop PC128,PC176;Change PR98 to 10K, PR101 to 4.7K.

Security Classification		Compal Secret Data		Compal Electronics, Inc.		
Issued Date	2010/03/18	Deciphered Date	2011/03/18	Title		
				Hardware-PIR1		
THIS SHEET OF ENGINEERING DRAWING IS THE PROPRIETARY PROPERTY OF COMPAL ELECTRONICS, INC. AND CONTAINS CONFIDENTIAL AND TRADE SECRET INFORMATION. THIS SHEET MAY NOT BE TRANSFERRED FROM THE CUSTODY OF THE COMPETENT DIVISION OF R&D DEPARTMENT EXCEPT AS AUTHORIZED BY COMPAL ELECTRONICS, INC. NEITHER THIS SHEET NOR THE INFORMATION IT CONTAINS MAY BE USED BY OR DISCLOSED TO ANY THIRD PARTY WITHOUT PRIOR WRITTEN CONSENT OF COMPAL ELECTRONICS, INC.				Size Custom	Document Number LA-6501P	Rev 0.2
				Date:	Tuesday, April 27, 2010	Sheet 33 of 35

Item	Date	Fixed Issue	Rev.	PG#	Modify List
26	2010/03/12	Change LAN IC	0.1	P.19	Change U22 from RTL8103EL-VB-GR to RTL8105E-VB-GR.
27	2010/03/16	For vender Realtek request	0.1	P.20	Change R1153 from 100K to 10K.
28	2010/03/18	Change +3V_LAN rising time > lms	0.1	P.23	Add C239,C165,C164,Q19,Q4,R134,R189 and de-pop J4
29	2010/03/22	Change KB926 GPIO definition	0.1	P.20	Change BT_RADIO_OFF# from pin108 to pin17
30	2010/03/22	Add card reader IC RTS5160-GR to MB	0.1	P.20	Add U12 card reader IC RTS5160-GR
31	2010/03/23	For vender Realtek request	0.1	P.19	Change U22 Pin 12,6,9,41 to NC;connect Pin 3,6 to together after via one 0.01uF cap. to GND;change C139, C127 to 27P.
32	2010/03/24	For EC team request	0.1	P.21	Pin38 net PM_CLKRUN# BOM @ 0ohm
33	2010/03/24	For EC team request	0.1	P.12	PCH pin AC19 net PM_CLKRUN# pull low 10K ohm
34	2010/03/25	Changer FLEA card DDR3 to DDR2 for cost	0.1	P.15	Change from K4B1G1646E-HCF8 to W9751G6IB-25
35	2010/03/26	Changer USB connector	0.1	P.23	Change JP16 from SUYIN_020133MR004S536ZR to ACON_UARB2-4K1926
36	2010/03/29	Broadcom request pull up GPIO_06 to 3V_BCM	0.1	P.15	Change U43 GPIO_06 pull up to +3V_BCM
36	2010/03/30	For speaker change from 2 to 1	0.1	P.17	Change JP55 from 4 pins to 2 pins
37	2010/04/15	For BOM error	0.2	P.19	Add C535 for BOM error
38	2010/04/15	For BOM error	0.2	P.23	Add R189,Q4 for BOM error
39	2010/04/15	For EC team request add 100K pull low	0.2	P.25	Add R128 pull low for EC
40	2010/04/15	For wake on LAN control net name error	0.2	P.20	Change KB926 pin98 net name from EN_WOL# to EN_WOL
41	2010/04/15	Change LAN RTL8105 to SWR mode	0.2	P.18	BOM @ L72,C149,C411,R296,C157,C431
42	2010/04/15	Change LAN ENSWREQ pin to pull Low	0.2	P.18	Delete R333 and Mount R334
43	2010/04/15	Change BOM from SD02800008L to SD028000080	0.2	P.20	Change R127,R284,R286,R287,R288 CPN
44	2010/04/16	Change BOM from SE070104Z80 to SE070104Z8L	0.2	P.19	Change C185,C534,C536 CPN
45	2010/04/16	Change BOM from SE074102K8L to SE074102K80	0.2	P.17	Change C419 CPN
46	2010/04/16	Change BOM from SE076104K80 to SE076104K8L	0.2	P.17	Change C132,C138,C165,C239 CPN
47	2010/04/16	Add net BT_RADIO_OFF# for JP54 pin19	0.2	P.14	Add R167 0 ohm for net BT_RADIO_OFF#
48	2010/04/21	Change MB ID to R02	0.2	P.20	Change R122 to 100K ohm and R127 to 8.2K ohm
49	2010/04/21	Modify BOM @ parts	0.2	P.09	BOM @ R1168,R1169,R41,R43
50	2010/04/21	Change BOM parts	0.2	P.10	Change U34 from SA000039N2L to SA000039N3L

Security Classification		Compal Secret Data		Compal Electronics, Inc.		
Issued Date	2010/03/18	Deciphered Date	2011/03/18	Title		
				Hardware-PIR-II		
THIS SHEET OF ENGINEERING DRAWING IS THE PROPRIETARY PROPERTY OF COMPAL ELECTRONICS, INC. AND CONTAINS CONFIDENTIAL AND TRADE SECRET INFORMATION. THIS SHEET MAY NOT BE TRANSFERRED FROM THE CUSTODY OF THE COMPETENT DIVISION OF R&D DEPARTMENT EXCEPT AS AUTHORIZED BY COMPAL ELECTRONICS, INC. NEITHER THIS SHEET NOR THE INFORMATION IT CONTAINS MAY BE USED BY OR DISCLOSED TO ANY THIRD PARTY WITHOUT PRIOR WRITTEN CONSENT OF COMPAL ELECTRONICS, INC.				Size	Document Number	Rev
				Custom	LA-6501P	0.2
				Date:	Monday, May 10, 2010	Sheet 34 of 35

Item	Date	Fixed Issue	Rev.	PG#	Modify List
51	2010/04/21	Change BOM parts	0.2	P.23	Change Q4,Q8,Q17 from SB570020110 to SB000008J00
52	2010/04/21	Change BOM parts	0.2	P.21	Change D19 from SC45248B010 to SC400001100
53	2010/04/21	Change BOM parts	0.2	P.07	Change C1117,C1124 from SE049225Z8L to SE107225K8L
54	2010/04/21	Change LAN chip from ver.B to ver.C	0.2	P.18	Change U22 from SA00003PO10 to SA00003PO20
55	2010/04/21	Delete external MIC function	0.2	P.16	Delete JP61
56	2010/04/27	Delete touch panel function	0.2	P.12	Delete USB port5 nets
57	2010/04/27	Delete fan function	0.2	P.21	Delete JP14
58	2010/04/27	Delete USB port function	0.2	P.12	Delete USB port1 nets
59	2010/04/27	Change camera voltage from +5VALW to +3VS	0.2	P.09	Change R35 pin1 to +3VS
60	2010/04/29	Change BOM for EOL parts	0.2	P.23	Change Q2,Q7,Q9,Q16,Q23,Q24 from SB570020110 to SB000009080 or SB000008J00
61	2010/04/29	Change BOM for EOL parts	0.2	P.12	Change X4 from SJ100005L0L to SJ10000B500
62	2010/04/29	Change BOM for EOL parts	0.2	P.21	Change U28 from SA00002TO00 to SA00002KI00
63	2010/05/06	Delete U14 for just two USB ports	0.2	P.22	Delete U14 and +USB_RIGHT,+USB_LEFT change to +USB_VCC
64	2010/05/06	Change parts package	0.2	P.35	Change U45(BC847BS) to Q83,Q84(MMBT3904)
65	2010/05/06	Change amplifier gain from 10dB to 15.6dB	0.2	P.16	BOM @ R714,R715 and mount R713,R716
66	2010/05/06	Add ESD solution for EMI	0.2	P.18	Add U42,U43 to RJ45 connector
67					
68					
69					
70					
71					
72					
73					
74					
75					

<http://hobi-elektronika.net>

Security Classification		Compal Secret Data		Compal Electronics, Inc.	
Issued Date	2010/03/18	Deciphered Date	2011/03/18	Title	
				Hardware-PIR-II	
THIS SHEET OF ENGINEERING DRAWING IS THE PROPRIETARY PROPERTY OF COMPAL ELECTRONICS, INC. AND CONTAINS CONFIDENTIAL AND TRADE SECRET INFORMATION. THIS SHEET MAY NOT BE TRANSFERRED FROM THE CUSTODY OF THE COMPETENT DIVISION OF R&D DEPARTMENT EXCEPT AS AUTHORIZED BY COMPAL ELECTRONICS, INC. NEITHER THIS SHEET NOR THE INFORMATION IT CONTAINS MAY BE USED BY OR DISCLOSED TO ANY THIRD PARTY WITHOUT PRIOR WRITTEN CONSENT OF COMPAL ELECTRONICS, INC.				Size Custom	Document Number LA-6501P
				Date:	Friday, May 07, 2010
				Sheet	35 of 35
				Rev	0.2