

COMPAL CONFIDENTIAL

MODEL NAME : **TOBAGO**

COMPAL P/N : **45128331001/45128331002**

PCB NO : **LA2151**

Revision : **1.0 (DELL: A00)**

TOBAGO Schematics Document

**uFCBGA/uFCPGA Mobile Dothan
Intel Alviso + ICH6M**

2004-11-03

REV : 1.0 (DELL: A00)

PROPRIETARY NOTE: THIS SHEET OF ENGINEERING DRAWING AND SPECIFICATIONS CONTAINS CONFIDENTIAL TRADE SECRET AND OTHER PROPRIETARY INFORMATION OF DELL INC. ("DELL") THIS DOCUMENT MAY NOT BE TRANSMITTED OR COPIED WITHOUT THE EXPRESS WRITTEN AUTHORIZATION OF DELL. IN ADDITION, NEITHER THIS SHEET NOR THE INFORMATION IT CONTAINS MAY BE USED BY OR DISCLOSED TO ANY THIRD PARTY WITHOUT DELL'S EXPRESS WRITTEN CONSENT.

DELL CONFIDENTIAL/PROPRIETARY



Compal Electronics, Inc.		
Title		
Cover Sheet		
Size	Document Number	Rev
	TOBAGO-LA2151	0.6
Date:	Wednesday, November 03, 2004	Sheet 1 of 51

Ceramic Capacitors :

0.1U_0402_6.3VXX

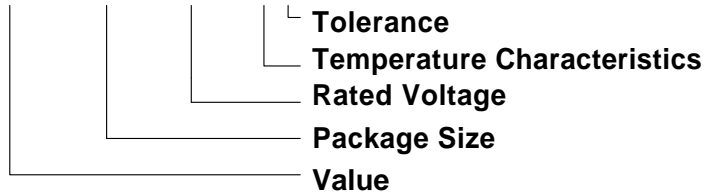

Tantalum or Polymer Capacitors :

10U_D2_10VX_R45

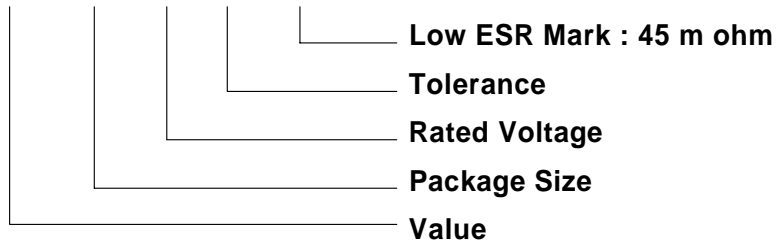

Capacitor Spec Guide:

Temperature Characteristics:

Symbol	0	1	2	3	4	5	6	7
CODE	Z5U	Z5V	Z5P	Y5U	Y5V	Y5P	X5R	X7R

8	9	A	B	C	D	E	F	G
NPO	COG	X6S	BJ	CH	CJ	CK	SH	SJ

H	I	J	K
UJ	UK	SL	X5S

Tolerance:

Symbol	A	B	C	D	F	G	H	J
CODE	+0.05PF	+0.1PF	+0.25PF	+0.5PF	+1PF	+2%	+3%	+5%

K	M	N	P	Q	V	X	Z	
+10%	+20%	+30%	+100,-0%	+30,-10%	+20,-10%	+40,-20%	+80,-20%	

NOTE1:

@XX : Depop component

1@XX : Pop for Integrated Graphic

2@XX : Pop for External Graphic

PCI TABLE

PCI DEVICE	IDSEL	REQ#/GNT#	PIRQ
CARD BUS	AD17	1	D,C
LAN	AD16	4	C
MINI PCI	AD19	3	D,B

PM TABLE

power plane / State	+3VALW +5VALW	+3VSUS +5VSUS +1.8VSUS +1.5VSUS	+5VRUN +3VRUN +1.8VRUN +0.9V_DDR_VTT +1.5VRUN +VCC_CORE +VCCP +15V
S0	ON	ON	ON
S1	ON	ON	ON
S3	ON	ON	OFF
S5 S4/AC	ON	OFF	OFF
S5 S4/AC don't exist	OFF	OFF	OFF

USB TABLE

USB PORT#	DESTINATION
0	NC
1	NC
2	Blue tooth
3	PCMCIA
4,5	REAR
6,7	SIDE

DELL CONFIDENTIAL/PROPRIETARY

Compal Electronics, Inc.

Index and Config.

Title		
Size	Document Number	Rev
	TOBAGO-LA2151	0.6
Date	Monday, October 18, 2004	Sheet 3 of 51

PROPRIETARY NOTE: THIS SHEET OF ENGINEERING DRAWING AND SPECIFICATIONS CONTAINS CONFIDENTIAL TRADE SECRET AND OTHER PROPRIETARY INFORMATION OF DELL INC. ("DELL"). THIS DOCUMENT MAY NOT BE TRANSMITTED OR COPIED WITHOUT THE EXPRESS WRITTEN AUTHORIZATION OF DELL. IN ADDITION, NEITHER THIS SHEET NOR THE INFORMATION IT CONTAINS MAY BE USED BY OR DISCLOSED TO ANY THIRD PARTY WITHOUT DELL'S EXPRESS WRITTEN CONSENT.

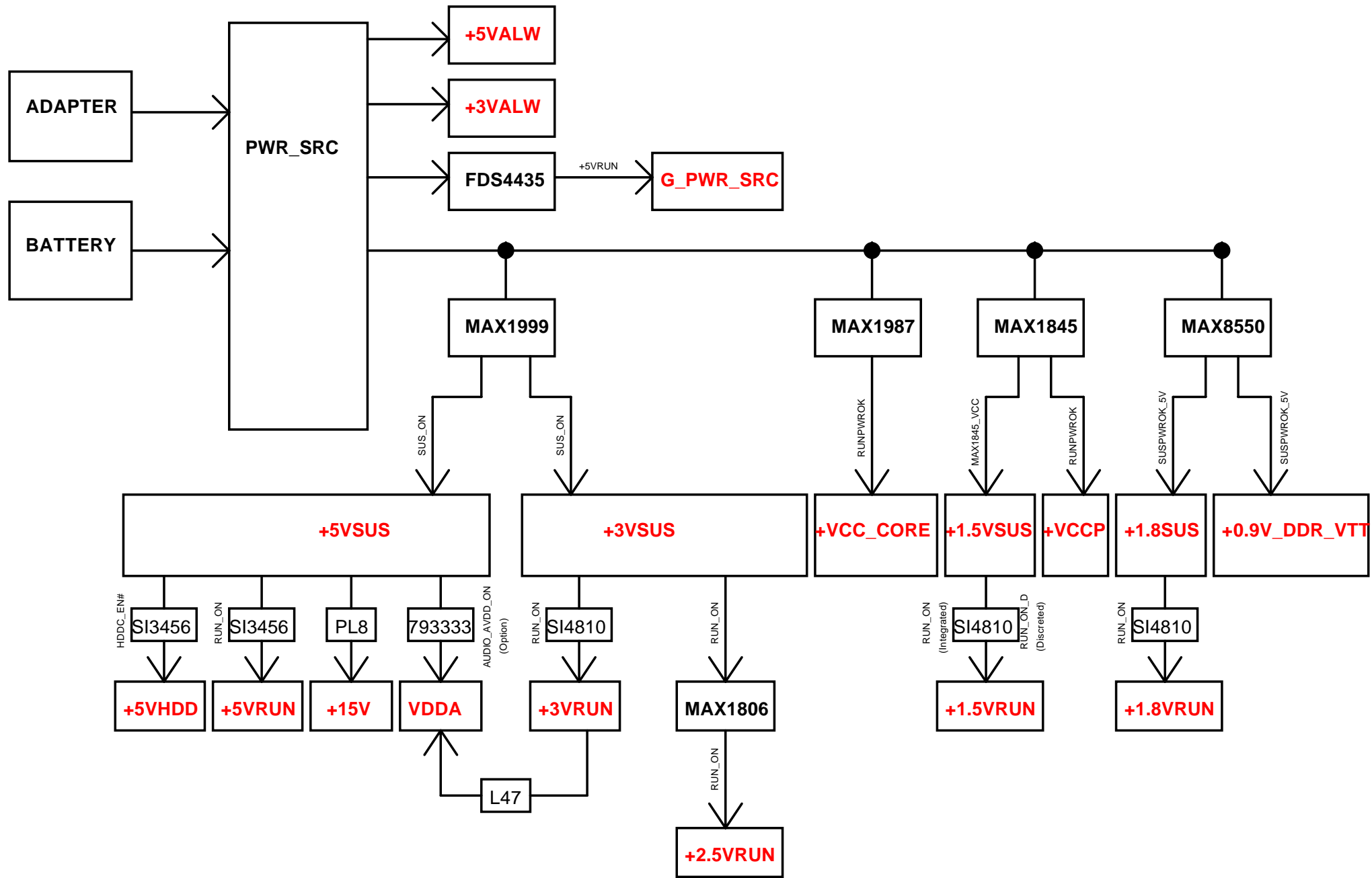

PROPRIETARY NOTE: THIS SHEET OF ENGINEERING DRAWING AND SPECIFICATIONS CONTAINS CONFIDENTIAL TRADE SECRET AND OTHER PROPRIETARY INFORMATION OF DELL INC. ("DELL"). THIS DOCUMENT MAY NOT BE TRANSFERRED OR COPIED WITHOUT THE EXPRESS WRITTEN AUTHORIZATION OF DELL. IN ADDITION, NEITHER THIS SHEET NOR THE INFORMATION IT CONTAINS MAY BE USED BY OR DISCLOSED TO ANY THIRD PARTY WITHOUT DELL'S EXPRESS WRITTEN CONSENT.



DELL CONFIDENTIAL/PROPRIETARY

Compal Electronics, Inc.

Title		Power Rail	
Size	Document Number	Date	Rev
	TOBAGO-LA2151	Monday, October 13, 2004	0.6
Date		Sheet	of
		1	4 of 51

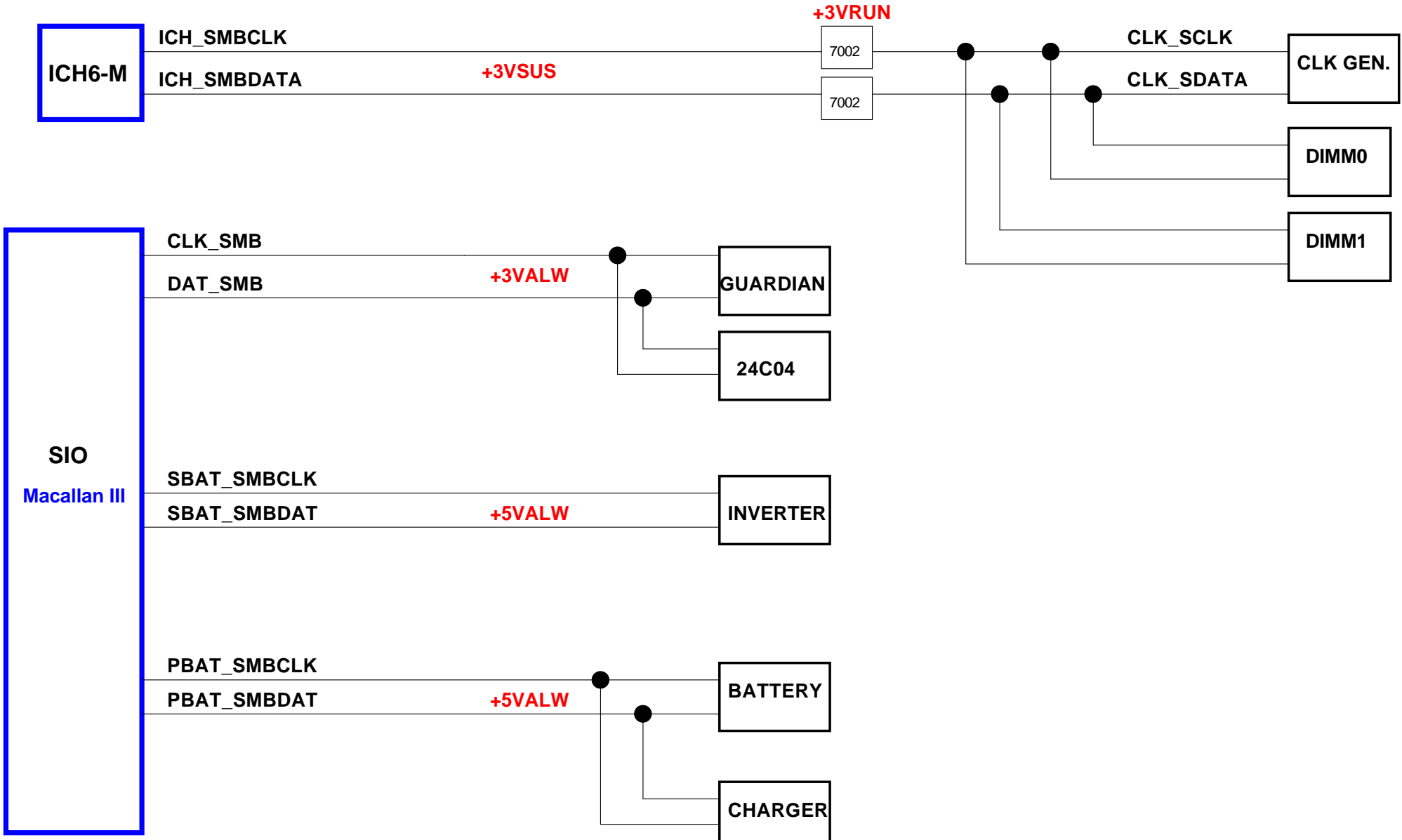

PROPRIETARY NOTE: THIS SHEET OF ENGINEERING DRAWING AND SPECIFICATIONS CONTAINS CONFIDENTIAL TRADE SECRET AND OTHER PROPRIETARY INFORMATION OF DELL INC. ("DELL"). THIS DOCUMENT MAY NOT BE TRANSFERRED OR COPIED WITHOUT THE EXPRESS WRITTEN AUTHORIZATION OF DELL. IN ADDITION, NEITHER THIS SHEET NOR THE INFORMATION IT CONTAINS MAY BE USED BY OR DISCLOSED TO ANY THIRD PARTY WITHOUT DELL'S EXPRESS WRITTEN CONSENT.



DELL CONFIDENTIAL/PROPRIETARY

Compal Electronics, Inc.

Title		
SMBUS TOPOLOGY		
Size	Document Number	Rev
	TOBAGO-LA2151	0.6
Date:	Monday, October 13, 2004	Sheet 5 of 51

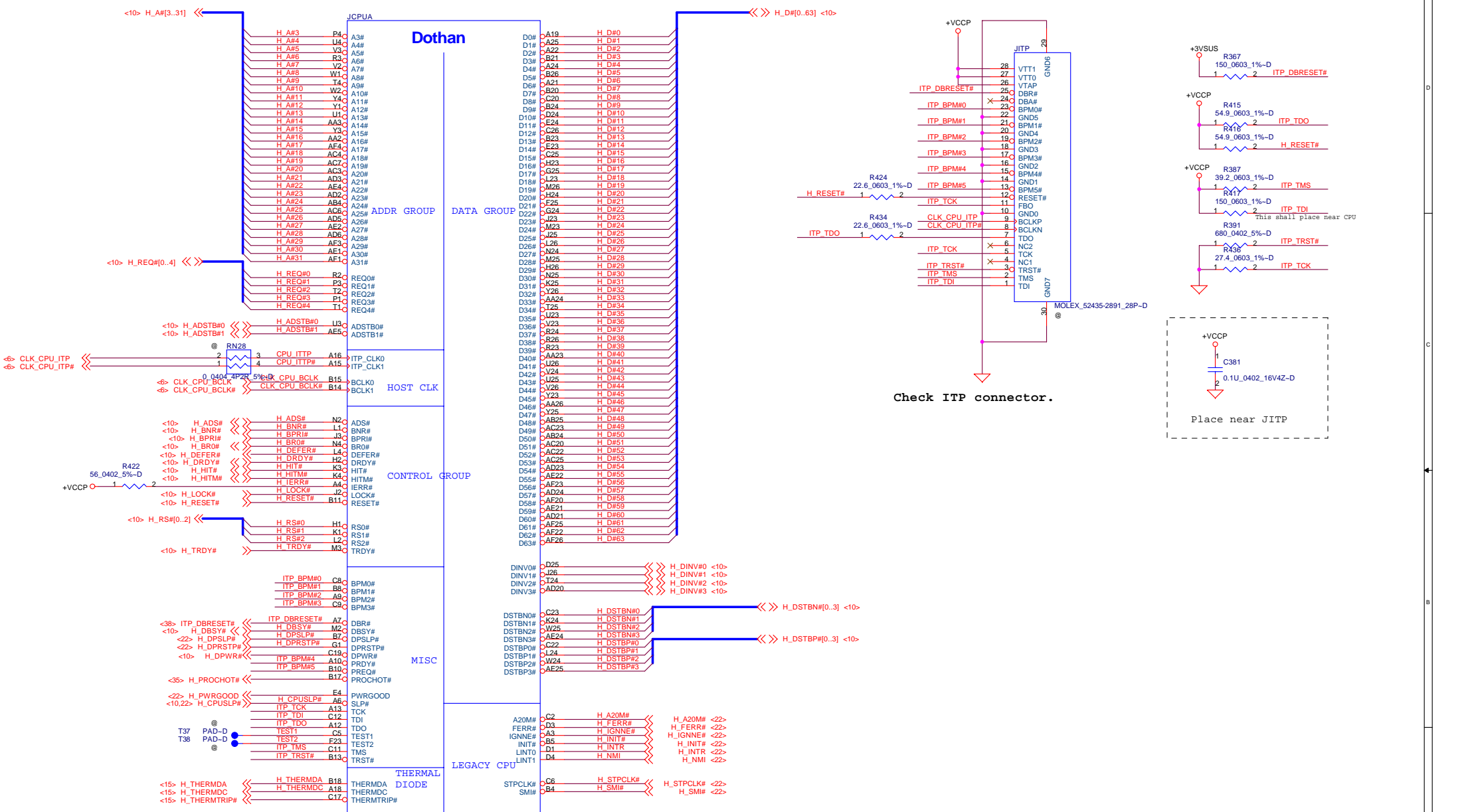

H_THERMDA, H_THERMDC routing together.
Trace width / Spacing = 10 / 10 mil

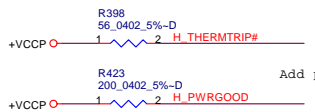

Add pullups for PWRGOOD and THERMTRIP per INTEL

Check ITP connector.

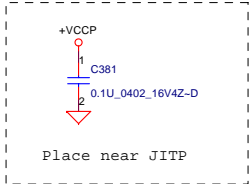

DELL CONFIDENTIAL/PROPRIETARY



Compal Electronics, Inc.		
Title Dothan Processor in mFCPGA479		
Size	Document Number TOBAGO-LA2151	Rev 0.6
Date	Monday, October 13, 2004	Sheet 7 of 51

PROPRIETARY NOTE: THIS SHEET OF ENGINEERING DRAWING AND SPECIFICATIONS CONTAINS CONFIDENTIAL TRADE SECRET AND OTHER PROPRIETARY INFORMATION OF DELL INC. ("DELL"). THIS DOCUMENT MAY NOT BE TRANSMITTED OR COPIED WITHOUT THE EXPRESS WRITTEN AUTHORIZATION OF DELL. IN ADDITION, NEITHER THIS SHEET NOR THE INFORMATION IT CONTAINS MAY BE USED BY OR DISCLOSED TO ANY THIRD PARTY WITHOUT DELL'S EXPRESS WRITTEN CONSENT.

Note:
 Pop R97 for Dothan-A,
 Pop R92 for Dothan-B

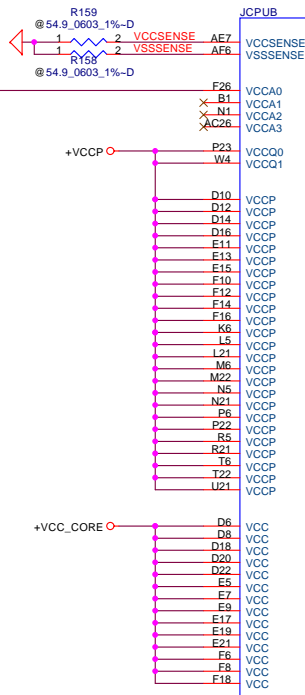
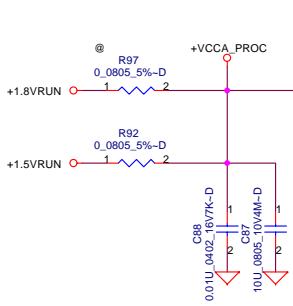

Dothan

POWER, GROUND, RESERVED SIGNALS AND NC

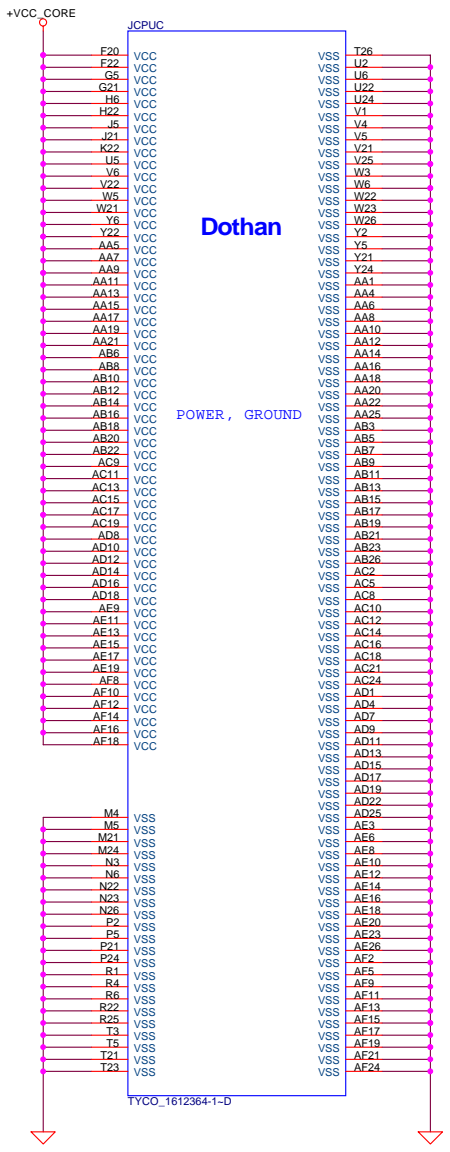

Dothan

POWER, GROUND

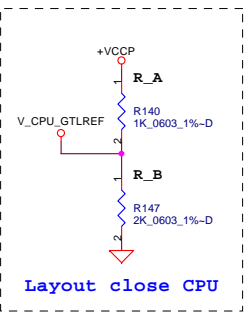

Layout close CPU

Resistor placed within 0.5" of CPU pin. Trace should be at least 25 miles away from any other toggling signal.

DELL CONFIDENTIAL/PROPRIETARY

Compal Electronics, Inc.



Title		Dothan Processor in mFCPGA479	
Size	Document Number	TOBAGO-LA2151	
Date:	Monday, October 18, 2004	Sheet	8 of 51

PROPRIETARY NOTE: THIS SHEET OF ENGINEERING DRAWING AND SPECIFICATIONS CONTAINS CONFIDENTIAL TRADE SECRET AND OTHER PROPRIETARY INFORMATION OF DELL INC. ("DELL"). THIS DOCUMENT MAY NOT BE TRANSMITTED OR COPIED WITHOUT THE EXPRESS WRITTEN AUTHORIZATION OF DELL. IN ADDITION, NEITHER THIS SHEET NOR THE INFORMATION IT CONTAINS MAY BE USED BY OR DISCLOSED TO ANY THIRD PARTY WITHOUT DELL'S EXPRESS WRITTEN CONSENT.

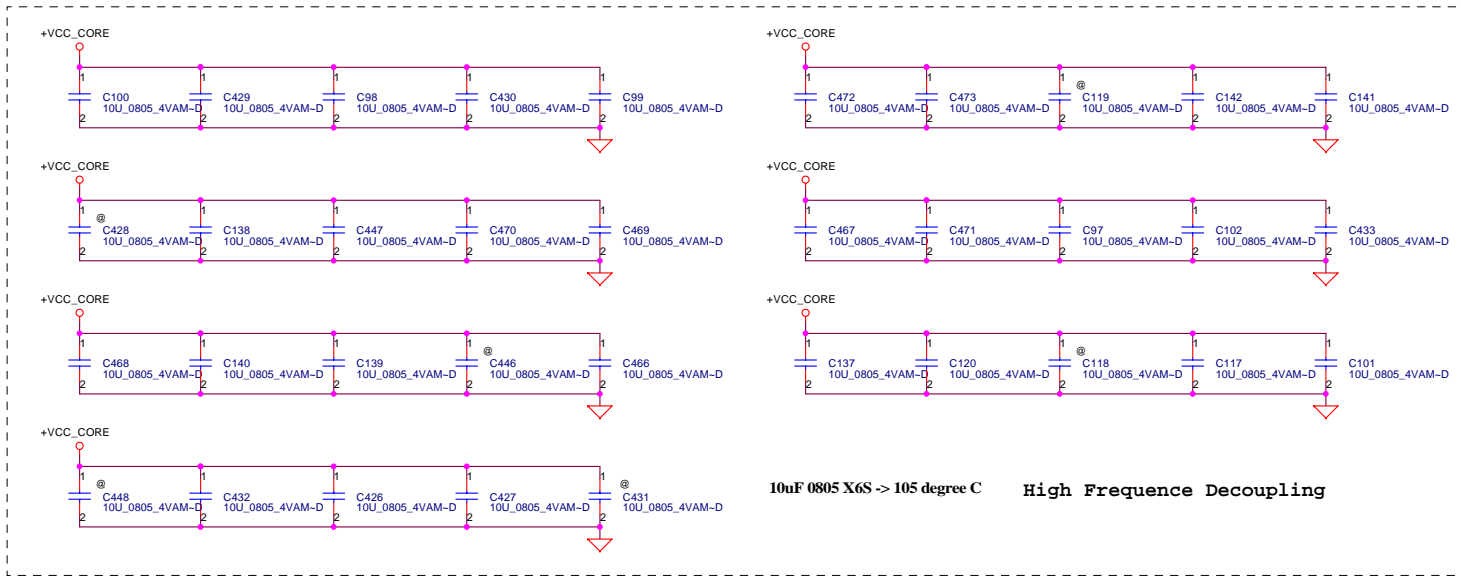

Near VCORE regulator.

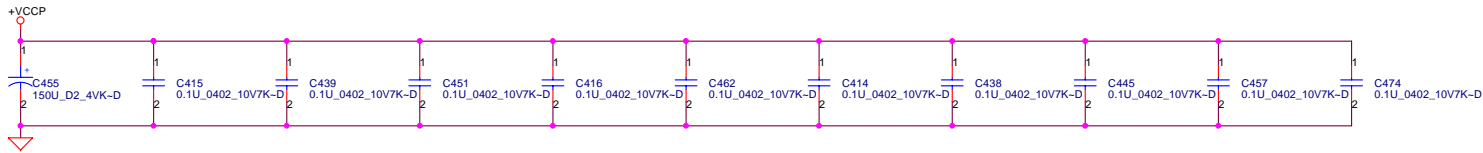
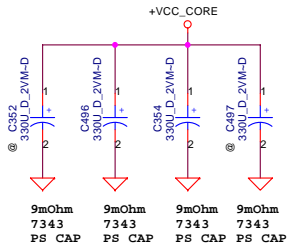

PROPRIETARY NOTE: THIS SHEET OF ENGINEERING DRAWING AND SPECIFICATIONS CONTAINS CONFIDENTIAL TRADE SECRET AND OTHER PROPRIETARY INFORMATION OF DELL INC. ("DELL"). THIS DOCUMENT MAY NOT BE TRANSFERRED OR COPIED WITHOUT THE EXPRESS WRITTEN AUTHORIZATION OF DELL. IN ADDITION, NEITHER THIS SHEET NOR THE INFORMATION IT CONTAINS MAY BE USED BY OR DISCLOSED TO ANY THIRD PARTY WITHOUT DELL'S EXPRESS WRITTEN CONSENT.



DELL CONFIDENTIAL/PROPRIETARY

Compal Electronics, Inc.

CPU Bypass

Title	CPU Bypass		Rev	0.6
Size	Document Number	TOBAGO-LA2151		
Date	Monday, October 13, 2004	Sheet	9	of 51

Note :
CFG3:17 has
internal pullup,
CFG18:19 has
internal pulldown

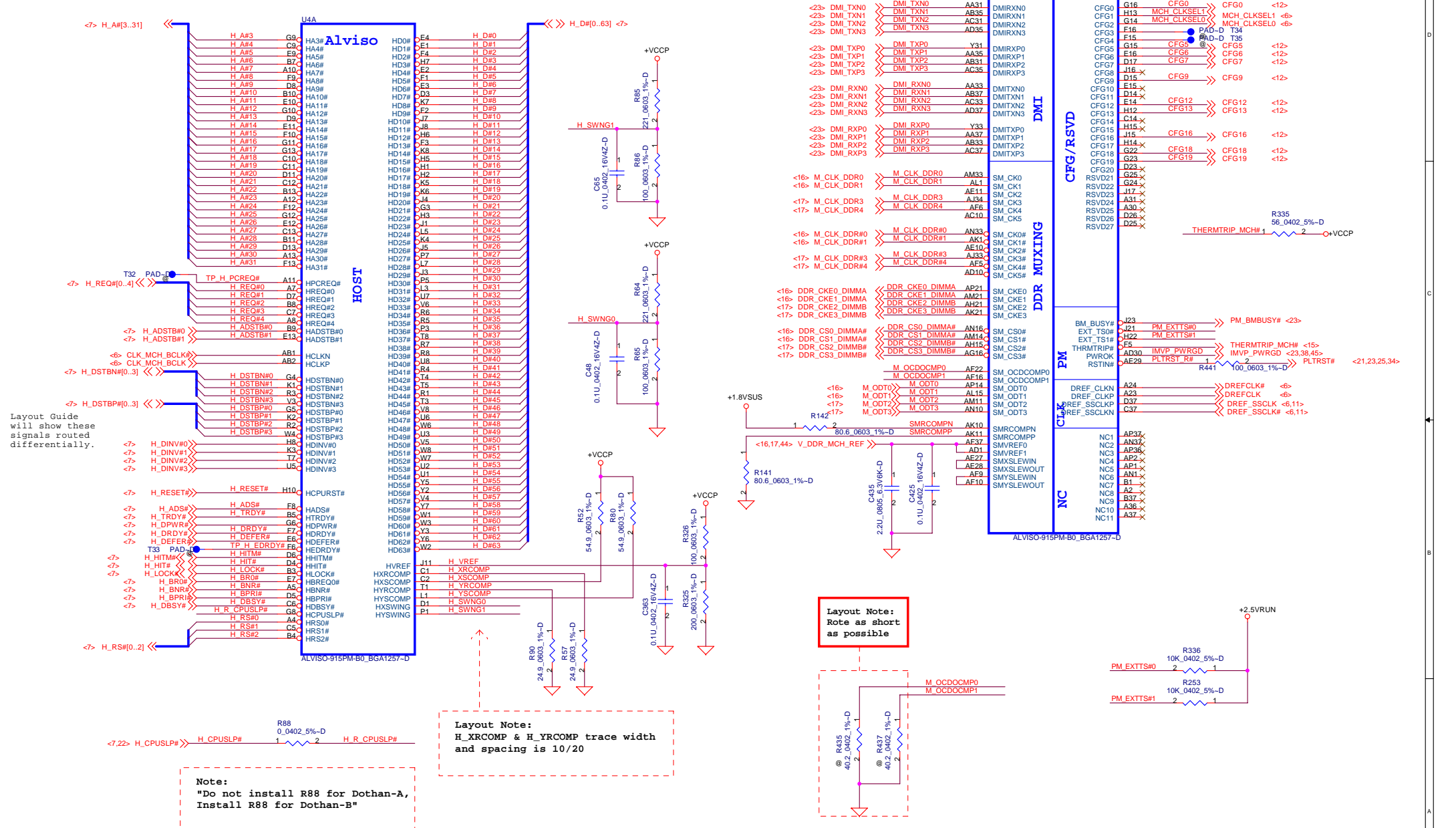

Layout Guide
will show these
signals routed
differentially.

Layout Note:
H_XRCOMP & H_YRCOMP trace width
and spacing is 10/20

Note:
"Do not install R88 for Dothan-A,
Install R88 for Dothan-B"

Layout Note:
Rote as short
as possible

DELL CONFIDENTIAL/PROPRIETARY

Compal Electronics, Inc.



Title		Alviso(1 of 5)	
Size	Document Number	TOBAGO-LA2151	
Date:	Wednesday, November 03, 2004	Sheet	10 of 51
			Rev 0.6

PROPRIETARY NOTE: THIS SHEET OF ENGINEERING DRAWING AND SPECIFICATIONS CONTAINS CONFIDENTIAL TRADE SECRET AND OTHER PROPRIETARY INFORMATION OF DELL INC. ("DELL"). THIS DOCUMENT MAY NOT BE TRANSMITTED OR COPIED WITHOUT THE EXPRESS WRITTEN AUTHORIZATION OF DELL. IN ADDITION, NEITHER THIS SHEET NOR THE INFORMATION IT CONTAINS WILL BE USED BY OR DISCLOSED TO ANY THIRD PARTY WITHOUT DELL'S EXPRESS WRITTEN CONSENT.

This Symbol as same as Intel CRB schematic, So Layout Guide will show these signals routed differentially.

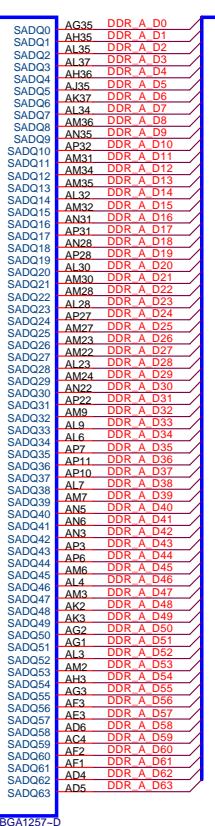
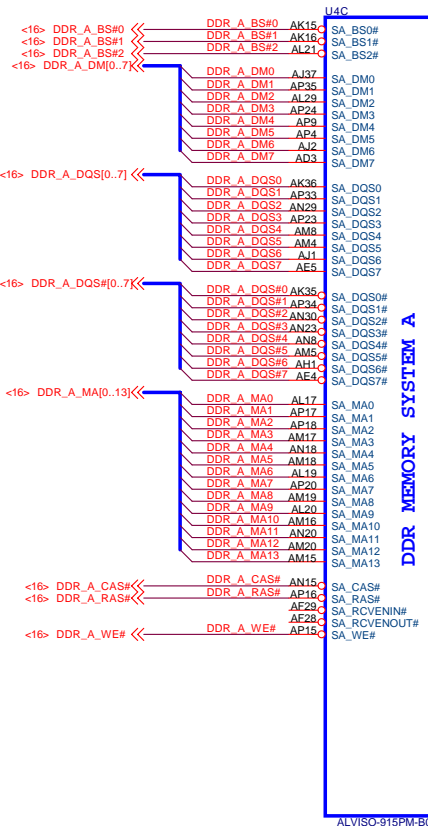

This Symbol as same as Intel CRB schematic, So Layout Guide will show these signals routed differentially.

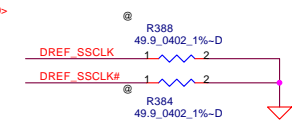
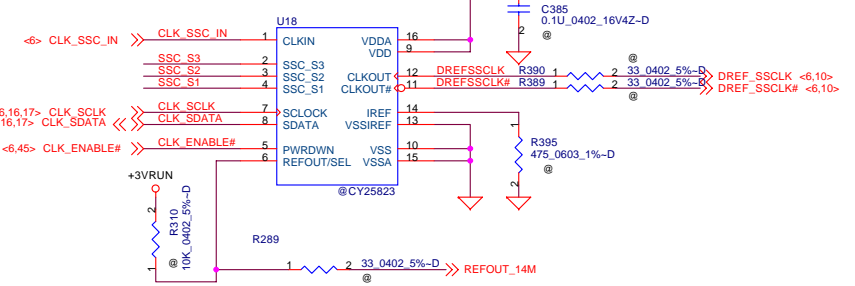
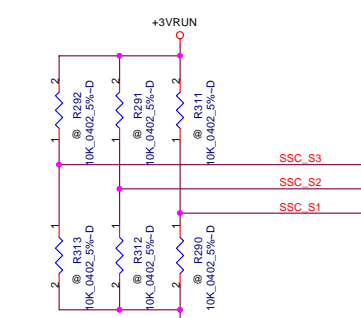
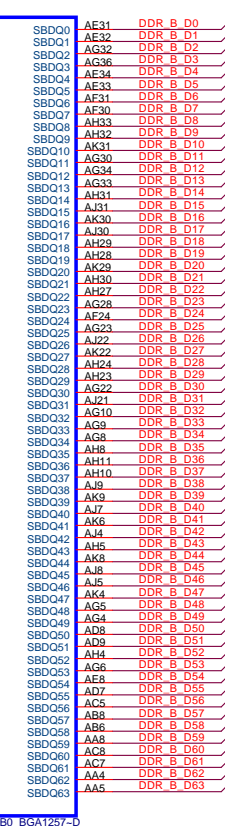
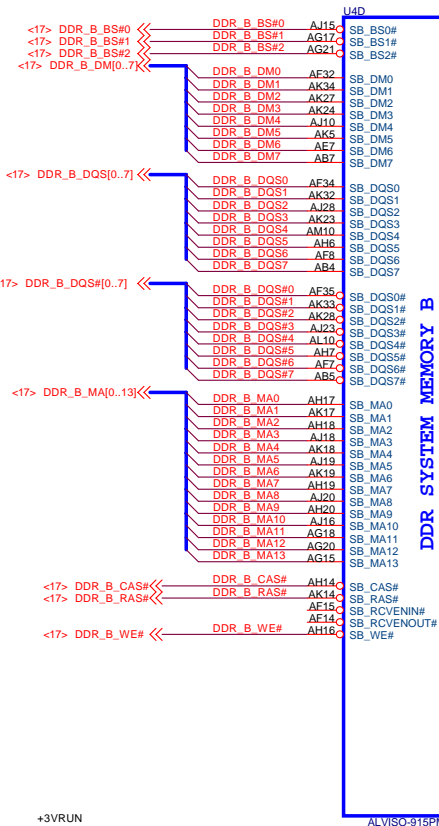

PROPRIETARY NOTE: THIS SHEET OF ENGINEERING DRAWING AND SPECIFICATIONS CONTAINS CONFIDENTIAL TRADE SECRET AND OTHER PROPRIETARY INFORMATION OF DELL INC. ("DELL"). THIS DOCUMENT MAY NOT BE TRANSFERRED OR COPIED WITHOUT THE EXPRESS WRITTEN AUTHORIZATION OF DELL. IN ADDITION, NEITHER THIS SHEET NOR THE INFORMATION IT CONTAINS MAY BE USED BY OR DISCLOSED TO ANY THIRD PARTY WITHOUT DELL'S EXPRESS WRITTEN CONSENT.

DELL CONFIDENTIAL/PROPRIETARY

Compal Electronics, Inc.

Alviso(2 of 5)

TOBAGO-LA2151

Date: Monday, October 18, 2004 Sheet 11 of 51

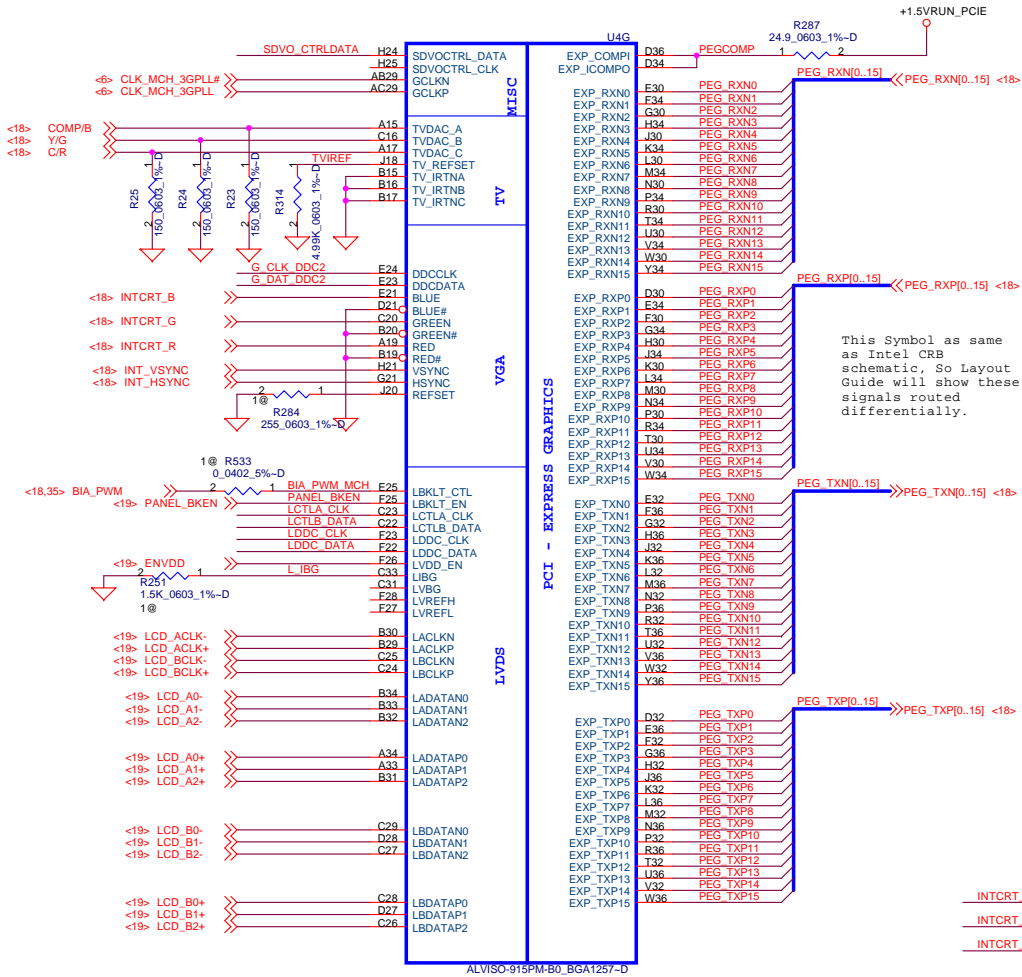

Strap Table

CFG5	Low = DMI x 2 High = DMI x 4 *
CFG6	Low = DDR-II * High = DDR-I
CFG7	Low = DT/Transportable CPU High = Mobile CPU *
CFG9	Low = Reverse Lane High = Normal Operation *
CFG[13:12]	00 = Reserved 01 = XOR Mode Enabled 10 = All Z Mode Enabled 11 = Normal Operation *
CFG16 (FSB Dynamic ODT)	Low = Disabled High = Enabled *
CFG18 (VCC Select)	Low = 1.05V (Default) * High = 1.5V
CFG19 (VTT Select)	Low = 1.05V (Default) * High = 1.2V
SDVO_CTRLDATA	Low = No SDVO Device Present (Default) * High = SDVO Device Present

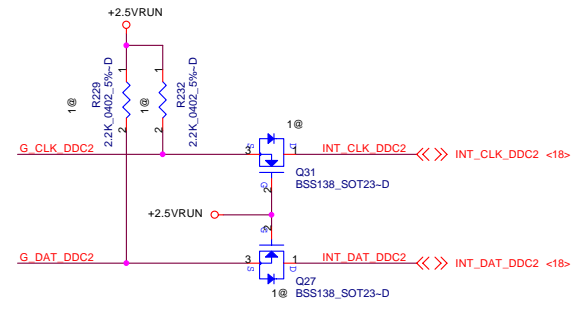
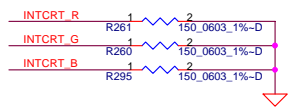
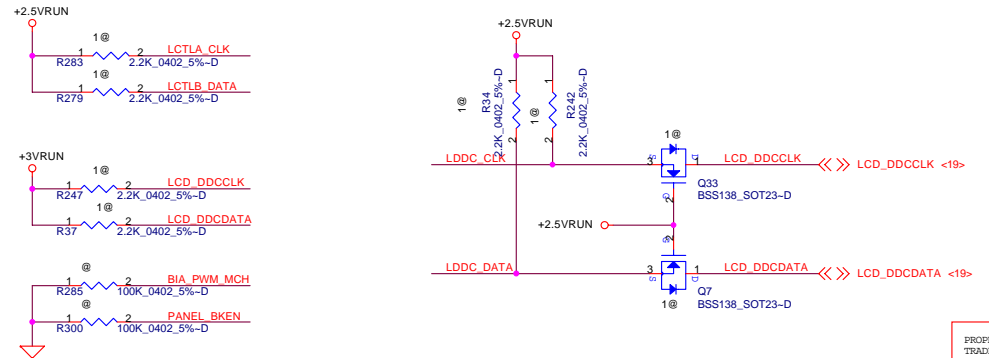
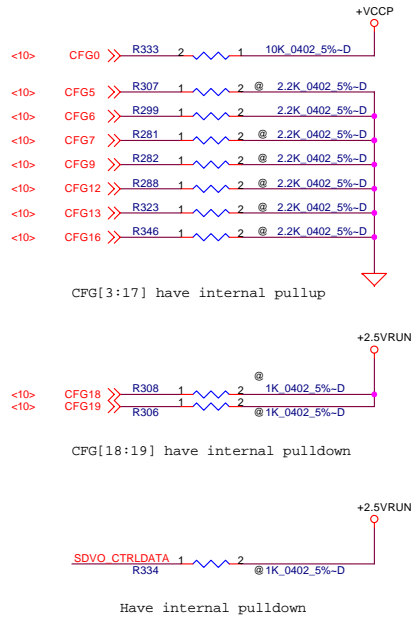

PROPRIETARY NOTE: THIS SHEET OF ENGINEERING DRAWING AND SPECIFICATIONS CONTAINS CONFIDENTIAL TRADE SECRET AND OTHER PROPRIETARY INFORMATION OF DELL INC. ("DELL"). THIS DOCUMENT MAY NOT BE TRANSMITTED OR COPIED WITHOUT THE EXPRESS WRITTEN AUTHORIZATION OF DELL. IN ADDITION, NEITHER THIS SHEET NOR THE INFORMATION IT CONTAINS MAY BE USED BY OR DISCLOSED TO ANY THIRD PARTY WITHOUT DELL'S EXPRESS WRITTEN CONSENT.



DELL CONFIDENTIAL/PROPRIETARY

Compal Electronics, Inc.		
Title Alviso(3 of 5)		
Size	Document Number TOBAGO-LA2151	Rev 0.6
Date:	Monday, October 18, 2004	Sheet 12 of 51

W=30 mils

POWER

POWER

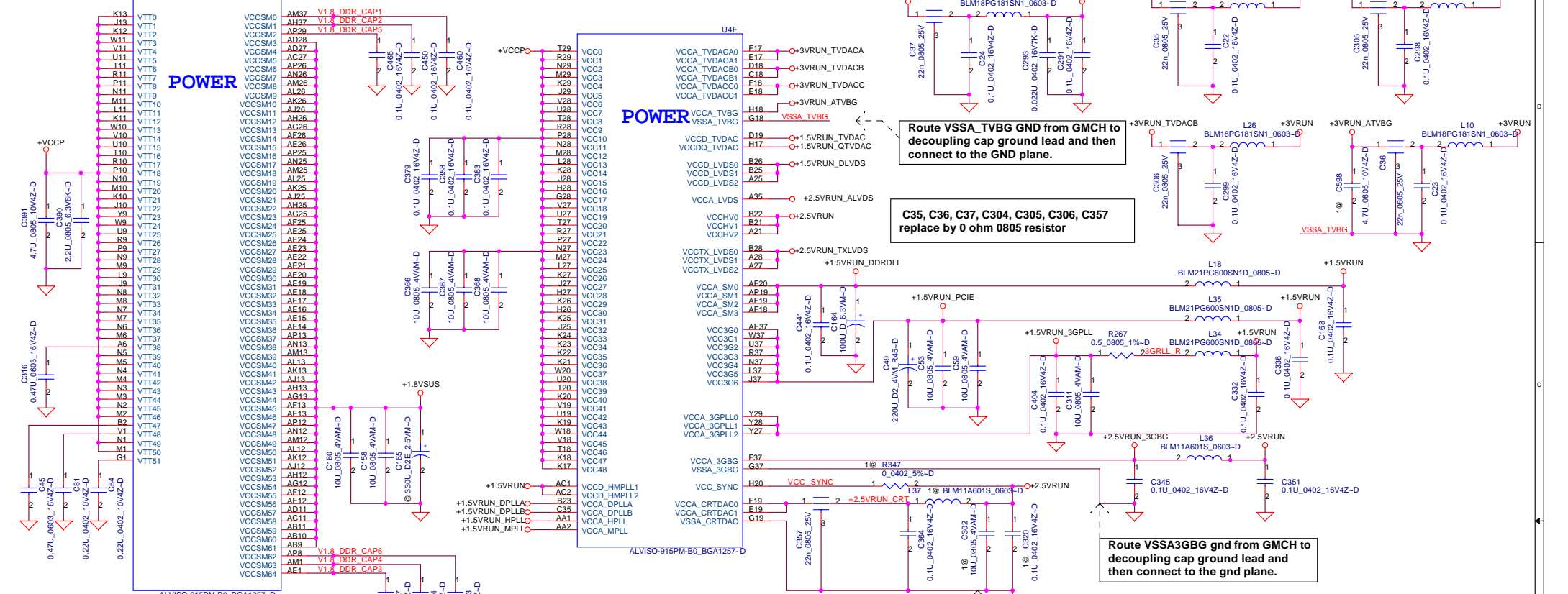

Route VSSA_TVBG GND from GMCH to decoupling cap ground lead and then connect to the GND plane.

C35, C36, C37, C304, C305, C306, C357 replace by 0 ohm 0805 resistor

Route VSSA3GBG gnd from GMCH to decoupling cap ground lead and then connect to the gnd plane.

CRTDAC: Route caps within 250mil of Alviso. Route FB within 3" of Alviso.

Route VSSACRTDAC gnd from GMCH to decoupling cap ground lead and then connect to the gnd plane.

Note : All VCCSM pin shorted internally.

Note : C294, C335 No stuff for Ext. VGA. Stuff for Int. VGA.

Note : R370, R357 stuff and R347, L37 no stuff for Ext. VGA. R370, R357 no stuff and R347, L37 stuff for Int. VGA.

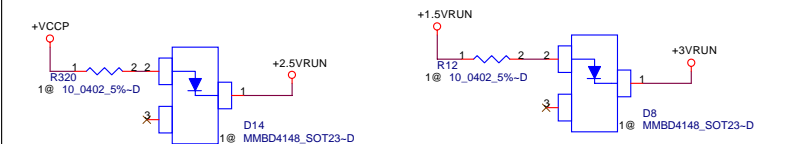

CRT DAC Voltage Follower Circuit - 700mV

TV DAC Voltage Follower Circuit - 700mV

PROPRIETARY NOTE: THIS SHEET OF ENGINEERING DRAWING AND SPECIFICATIONS CONTAINS CONFIDENTIAL TRADE SECRET AND OTHER PROPRIETARY INFORMATION OF DELL INC. ("DELL"). THIS DOCUMENT MAY NOT BE TRANSFERRED OR COPIED WITHOUT THE EXPRESS WRITTEN AUTHORIZATION OF DELL. IN ADDITION, NEITHER THIS SHEET NOR THE INFORMATION IT CONTAINS MAY BE USED BY OR DISCLOSED TO ANY THIRD PARTY WITHOUT DELL'S EXPRESS WRITTEN CONSENT.



DELL CONFIDENTIAL/PROPRIETARY

Compal Electronics, Inc.

Title		
Alviso(4 of 5)		
Size	Document Number	Rev
	TOBAGO-LA2151	0.6
Date:	Monday, October 13, 2004	Sheet 13 of 51

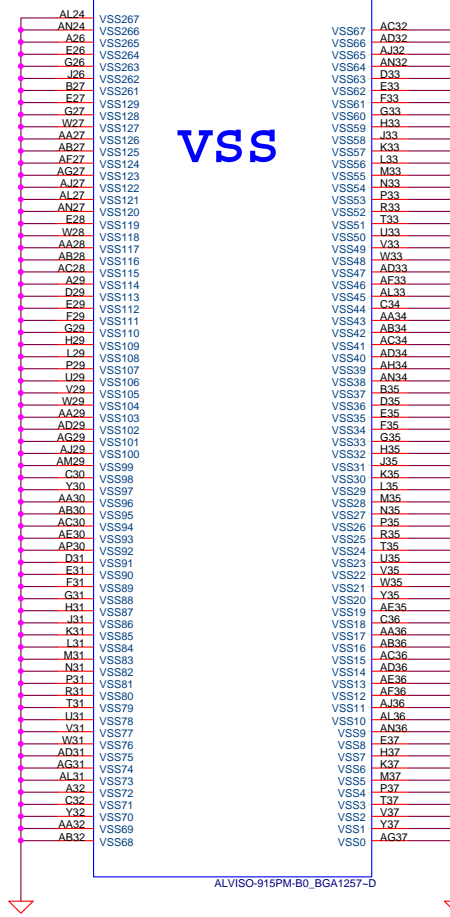
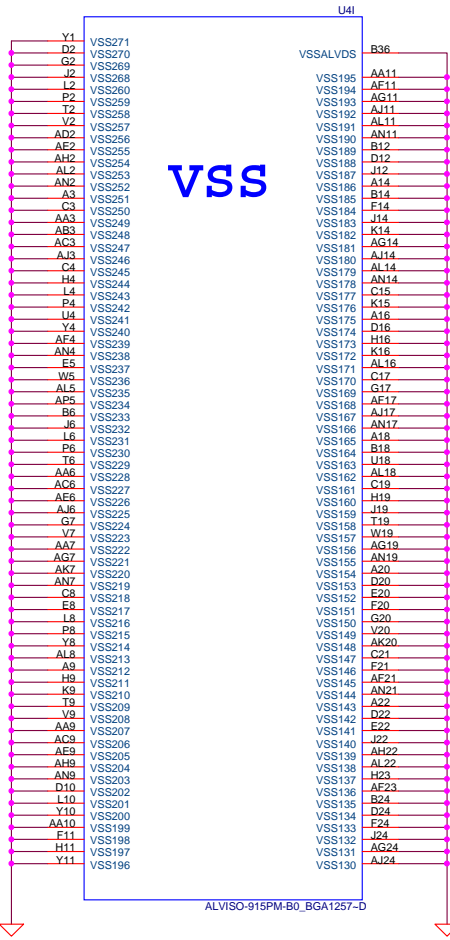
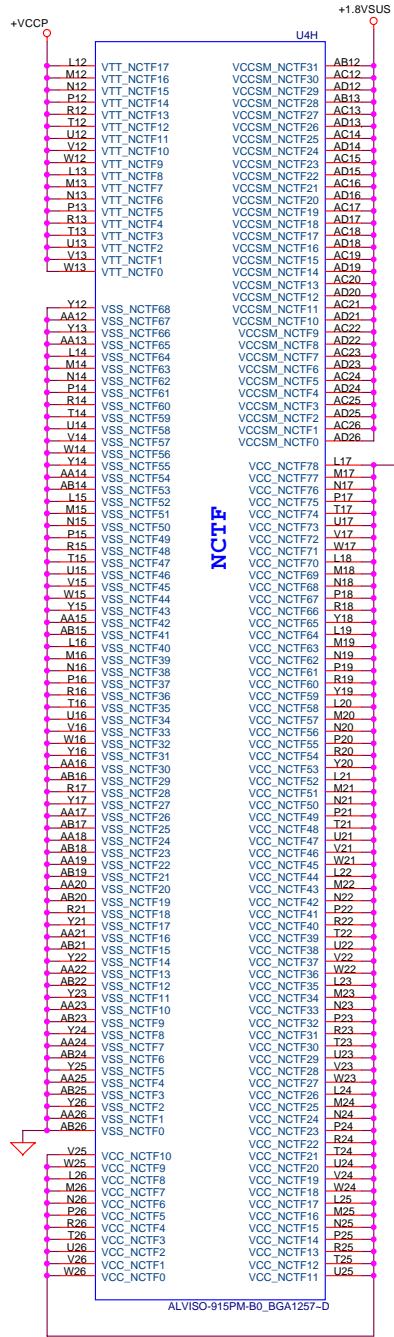

PROPRIETARY NOTE: THIS SHEET OF ENGINEERING DRAWING AND SPECIFICATIONS CONTAINS CONFIDENTIAL TRADE SECRET AND OTHER PROPRIETARY INFORMATION OF DELL INC. ("DELL"). THIS DOCUMENT MAY NOT BE TRANSFERRED OR COPIED WITHOUT THE EXPRESS WRITTEN AUTHORIZATION OF DELL. IN ADDITION, NEITHER THIS SHEET NOR THE INFORMATION IT CONTAINS MAY BE USED BY OR DISCLOSED TO ANY THIRD PARTY WITHOUT DELL'S EXPRESS WRITTEN CONSENT.



FAN1 Control and Tachometer

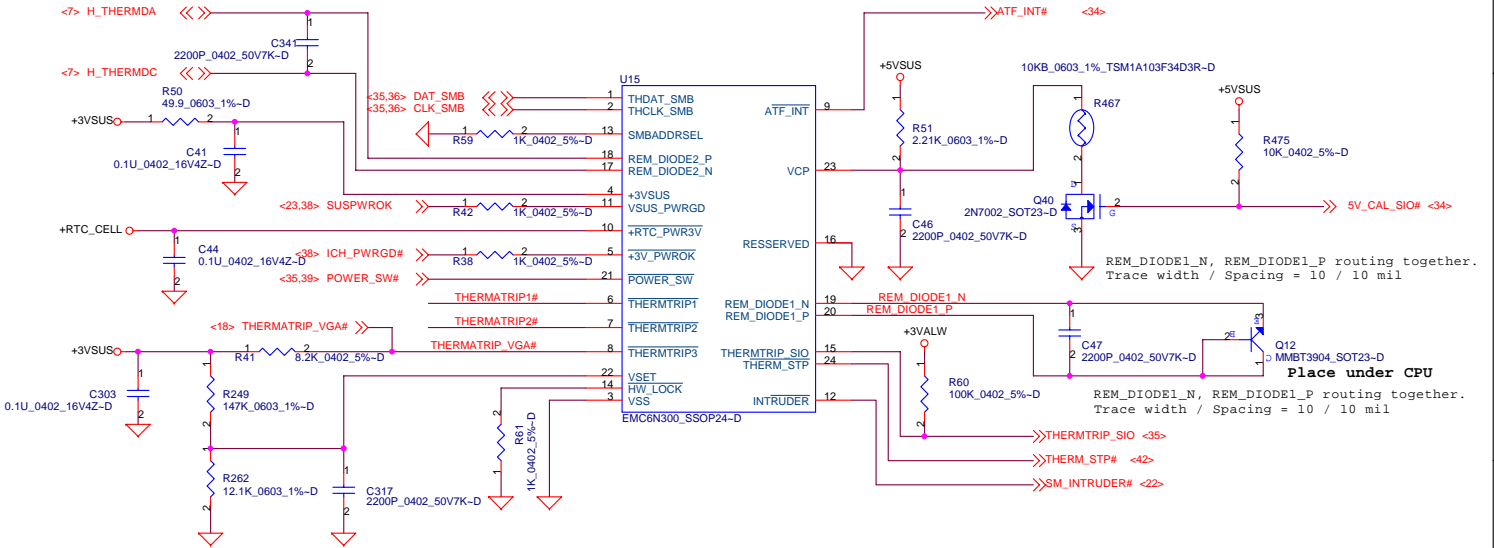
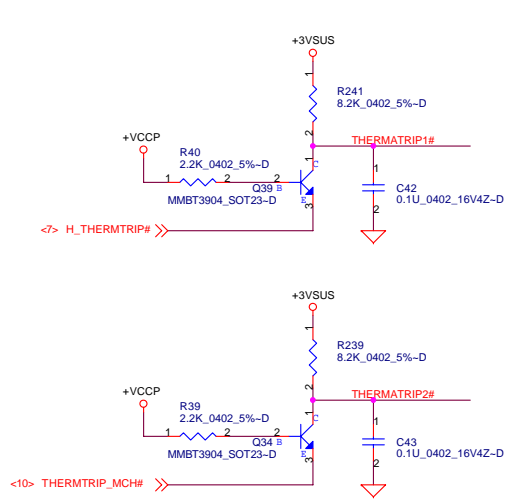
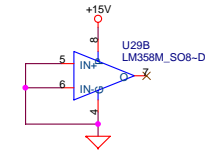
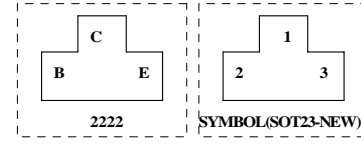
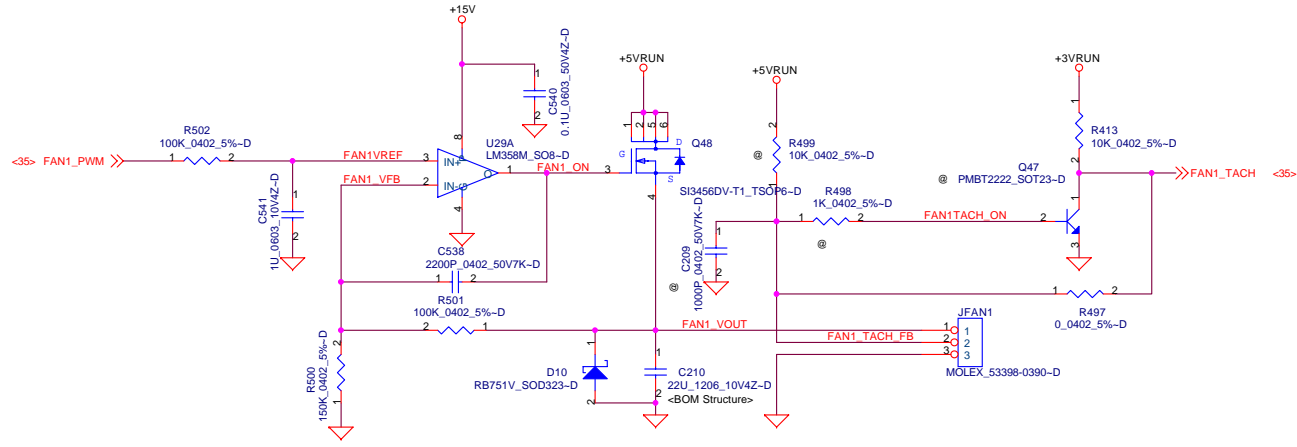

DELL CONFIDENTIAL/PROPRIETARY

Compal Electronics, Inc.



Title		
FAN & Thermal Sensor		
Size	Document Number	Rev
	TOBAGO-LA2151	0.6
Date:	Wednesday, November 03, 2004	Sheet 15 of 51

PROPRIETARY NOTE: THIS SHEET OF ENGINEERING DRAWING AND SPECIFICATIONS CONTAINS CONFIDENTIAL TRADE SECRET AND OTHER PROPRIETARY INFORMATION OF DELL INC. ("DELL"). THIS DOCUMENT MAY NOT BE TRANSFERRED OR COPIED WITHOUT THE EXPRESS WRITTEN AUTHORIZATION OF DELL. IN ADDITION, NEITHER THIS SHEET NOR THE INFORMATION IT CONTAINS MAY BE USED BY OR DISCLOSED TO ANY THIRD PARTY WITHOUT DELL'S EXPRESS WRITTEN CONSENT.

<11> DDR_A_DQS[0..7] <<>>
 <11> DDR_A_D[0..63] <<>>
 <11> DDR_A_DM[0..7] <<>>
 <11> DDR_A_DQS[0..7K] <<>>
 <11> DDR_A_MA[0..13] <<>>

Layout Note:
Place near JDIM1

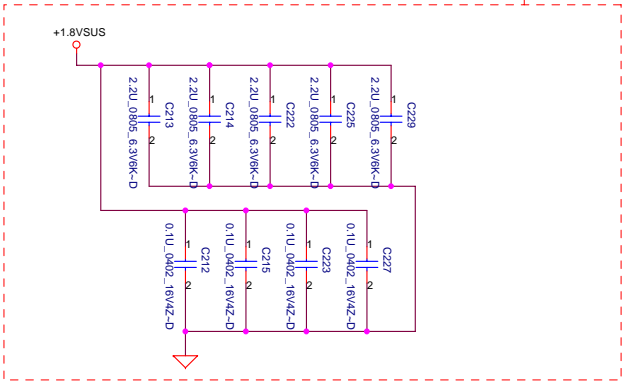

Layout Note:
Place one cap close to every 2 pullup resistors terminated to +0.9V_DDR_VTT

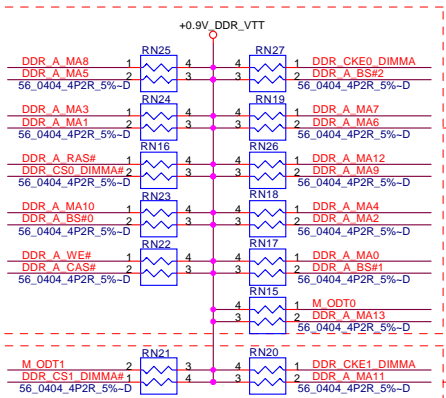
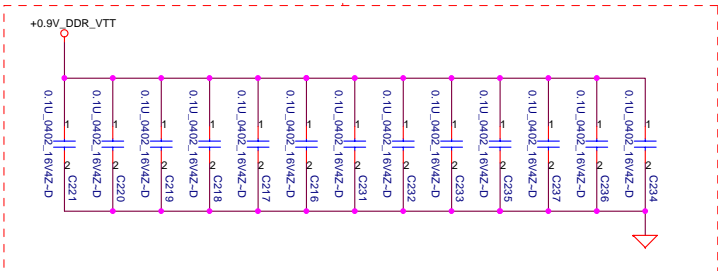

Layout Note:
Place these resistor closely DIM0, all trace length < 750 mil

Layout Note:
Place these resistor closely DIM0, all trace length Max=1.3"

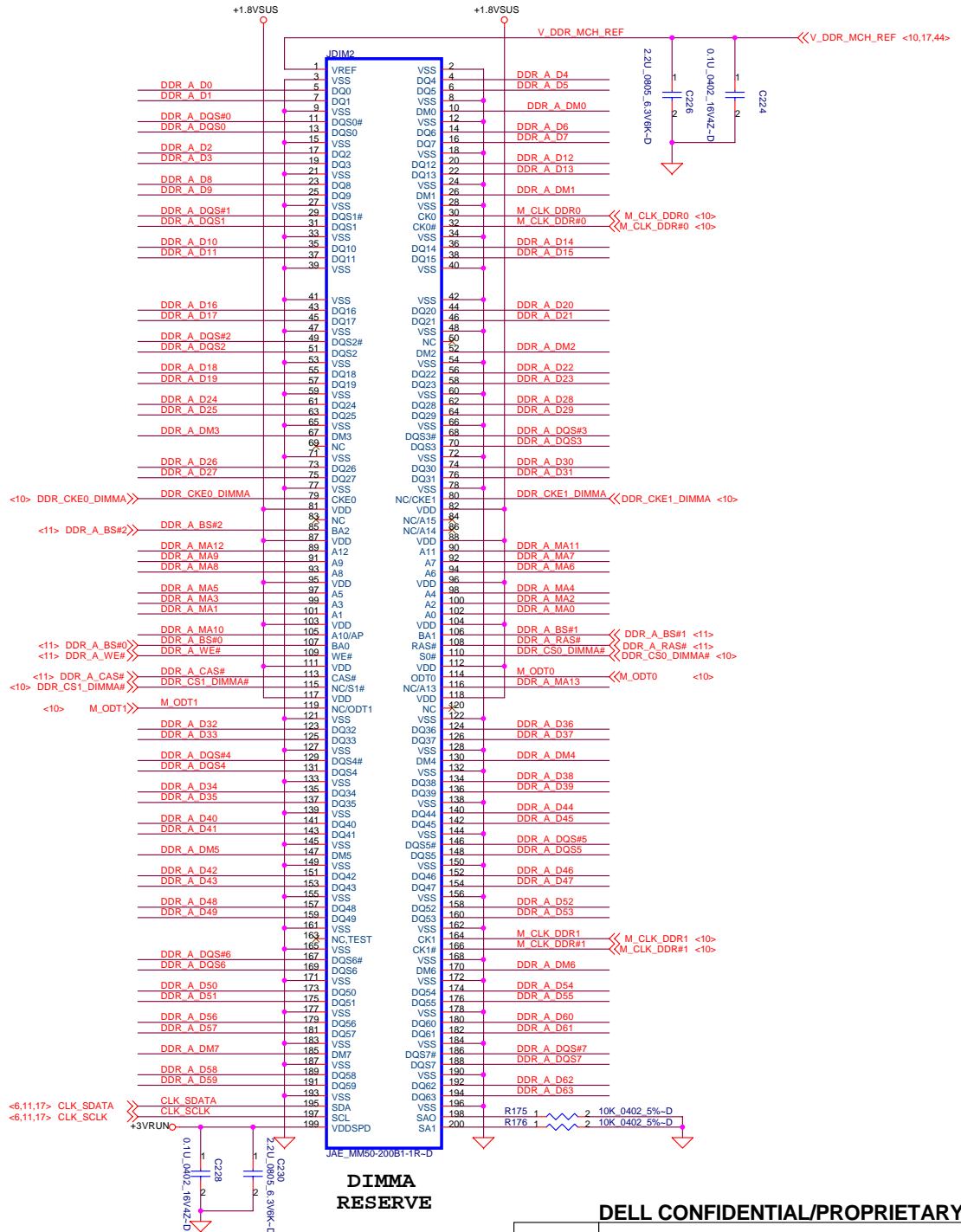

DIMMA RESERVE

DELL CONFIDENTIAL/PROPRIETARY



Compal Electronics, Inc.
DDR11-SODIMM SLOT1
 TOBAGO-LA2151
 Date: Monday, October 18, 2004 Sheet 16 of 51

PROPRIETARY NOTE: THIS SHEET OF ENGINEERING DRAWING AND SPECIFICATIONS CONTAINS CONFIDENTIAL TRADE SECRET AND OTHER PROPRIETARY INFORMATION OF DELL INC. ("DELL"). THIS DOCUMENT MAY NOT BE TRANSFERRED OR COPIED WITHOUT THE EXPRESS WRITTEN AUTHORIZATION OF DELL. IN ADDITION, NEITHER THIS SHEET NOR THE INFORMATION IT CONTAINS MAY BE USED BY OR DISCLOSED TO ANY THIRD PARTY WITHOUT DELL'S EXPRESS WRITTEN CONSENT.

<11> DDR_B_DQS#[0..7] <<>>
 <11> DDR_B_DQ[0..63] <<>>
 <11> DDR_B_DM[0..7] <<>>
 <11> DDR_B_DQS#[0..7] <<>>
 <11> DDR_B_MA[0..13] <<>>

Layout Note:
Place near JDIM2

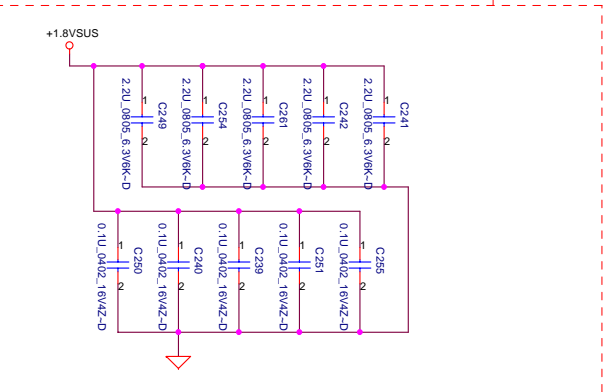

Layout Note:
Place one cap close to every 2 pullup resistors terminated to +0.9V_DDR_VTT

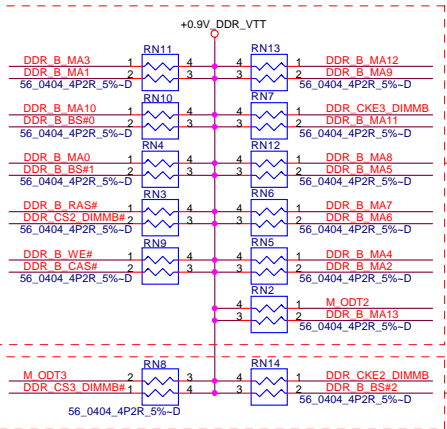
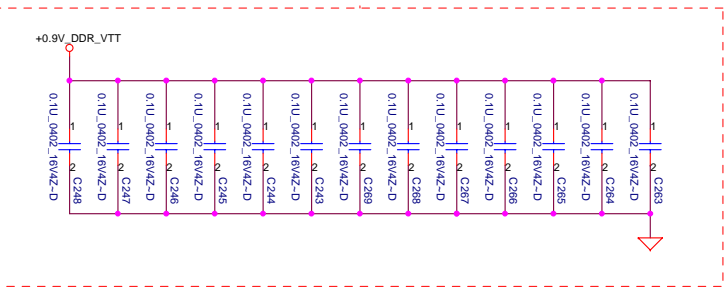

Layout Note:
Place these resistor closely DIMM0, all trace length <750 mil

Layout Note:
Place these resistor closely DIMM0, all trace length Max=1.3"

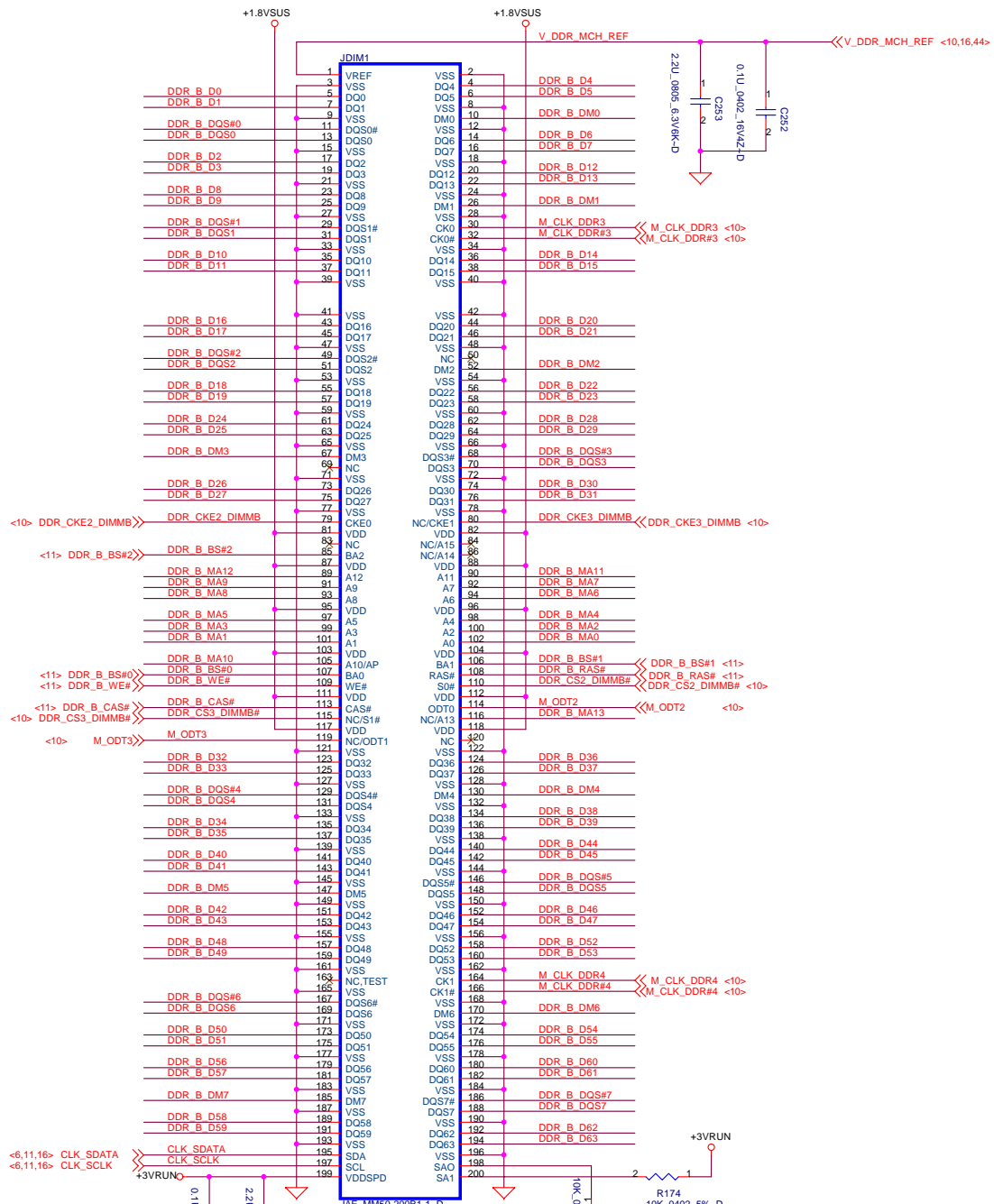

DIMMB STANDARD

PROPRIETARY NOTE: THIS SHEET OF ENGINEERING DRAWING AND SPECIFICATIONS CONTAINS CONFIDENTIAL TRADE SECRET AND OTHER PROPRIETARY INFORMATION OF DELL INC. ("DELL"). THIS DOCUMENT MAY NOT BE TRANSFERRED OR COPIED WITHOUT THE EXPRESS WRITTEN AUTHORIZATION OF DELL. IN ADDITION, NEITHER THIS SHEET NOR THE INFORMATION IT CONTAINS MAY BE USED BY OR DISCLOSED TO ANY THIRD PARTY WITHOUT DELL'S EXPRESS WRITTEN CONSENT.



DELL CONFIDENTIAL/PROPRIETARY

Compal Electronics, Inc.		
DDRII-SODIMM SLOT2		
File	Document Number	Rev
	TOBAGO-LA2151	0.6
Date:	Monday, October 18, 2004	Sheet 17 of 51

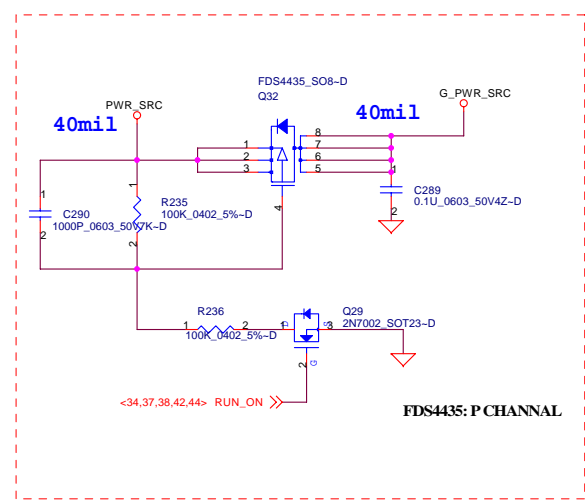
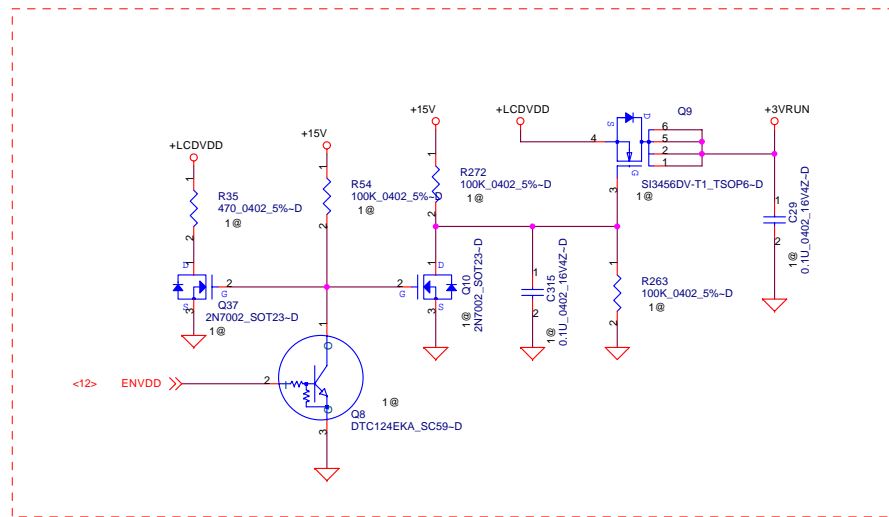
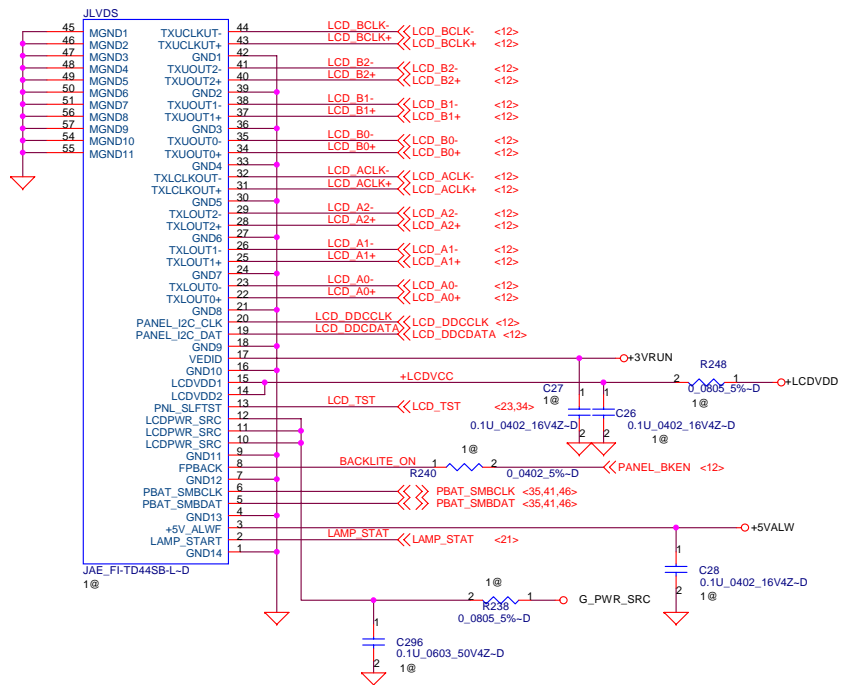

PROPRIETARY NOTE: THIS SHEET OF ENGINEERING DRAWINGS AND SPECIFICATIONS CONTAINS CONFIDENTIAL TRADE SECRET AND OTHER PROPRIETARY INFORMATION OF DELL, INC. ("DELL"). THIS DOCUMENT MAY NOT BE TRANSFERRED OR COPIED WITHOUT THE EXPRESS WRITTEN AUTHORIZATION OF DELL. IN ADDITION, NEITHER THIS SHEET NOR THE INFORMATION IT CONTAINS MAY BE USED BY OR DISCLOSED TO ANY THIRD PARTY WITHOUT DELL'S EXPRESS WRITTEN CONSENT.



DELL CONFIDENTIAL/PROPRIETARY

Compal Electronics, Inc.

Title		
Internal LVDS		
Size	Document Number	Rev
	TOBAGO-LA2151	0.6
Date:	Wednesday, November 03, 2004	Sheet 19 of 51

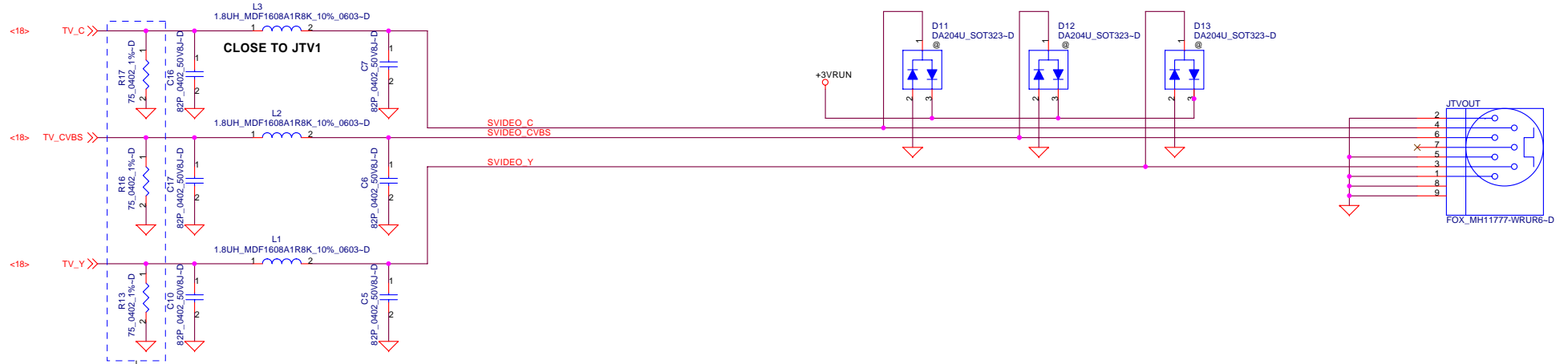

R13, R16, R17, R18, R19, and R20 Pop 150 ohm resistor for internal Gfx

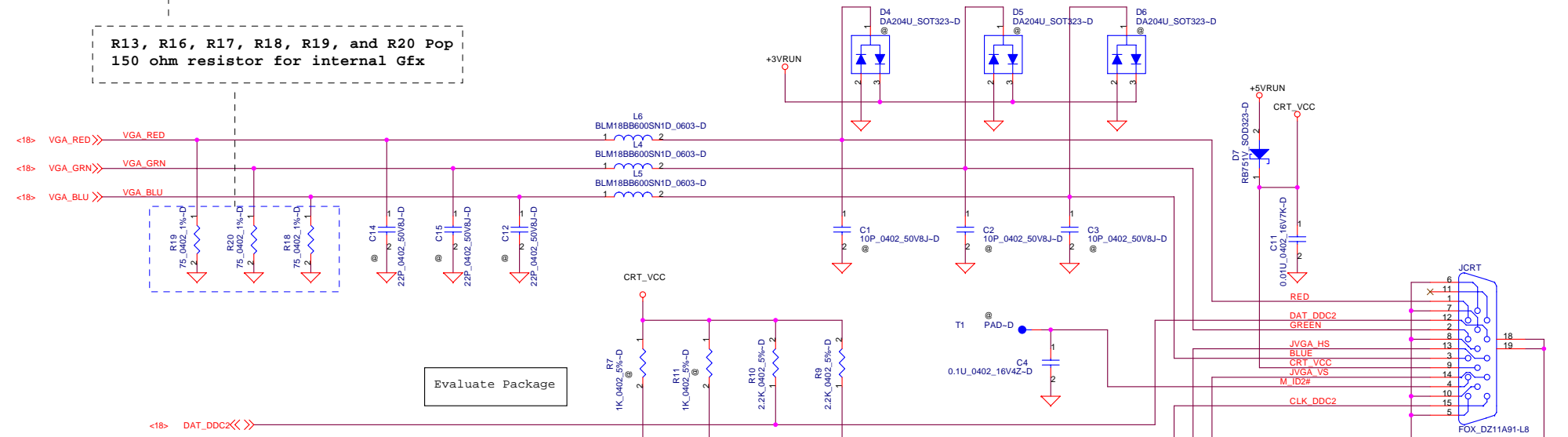

Evaluate Package

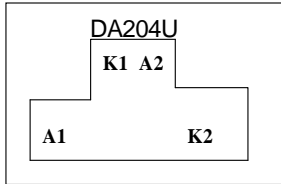
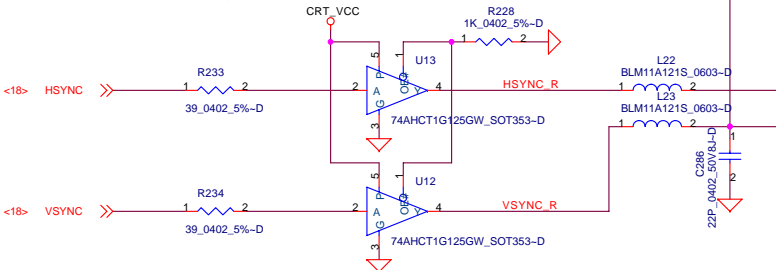

PROPRIETARY NOTE: THIS SHEET OF ENGINEERING DRAWINGS AND SPECIFICATIONS CONTAINS CONFIDENTIAL TRADE SECRET AND OTHER PROPRIETARY INFORMATION OF DELL INC. ("DELL") THIS DOCUMENT MAY NOT BE TRANSFERRED OR COPIED WITHOUT THE EXPRESS WRITTEN AUTHORIZATION OF DELL. IN ADDITION, NEITHER THIS SHEET NOR THE INFORMATION IT CONTAINS MAY BE USED BY OR DISCLOSED TO ANY THIRD PARTY WITHOUT DELL'S EXPRESS WRITTEN CONSENT.



DELL CONFIDENTIAL/PROPRIETARY

Compal Electronics, Inc.

Title		TOBAGO-LA2151	
Size	Document Number	Rev 0.6	
Date:	Monday, October 18, 2004	Sheet	20 of 51

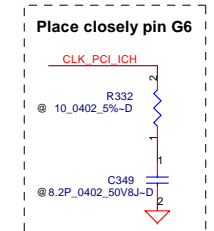
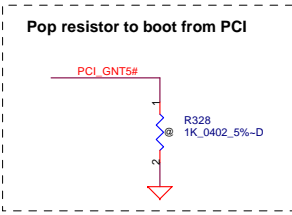
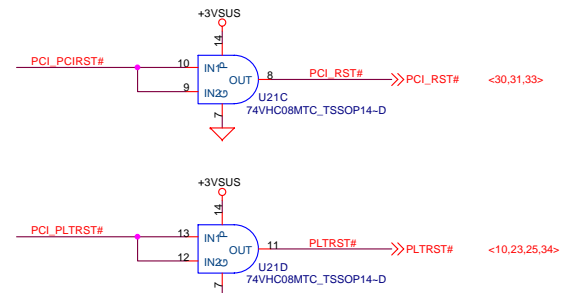
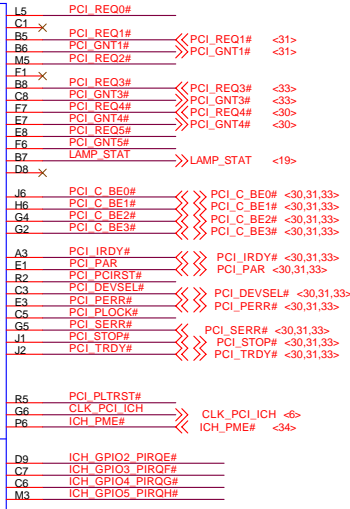
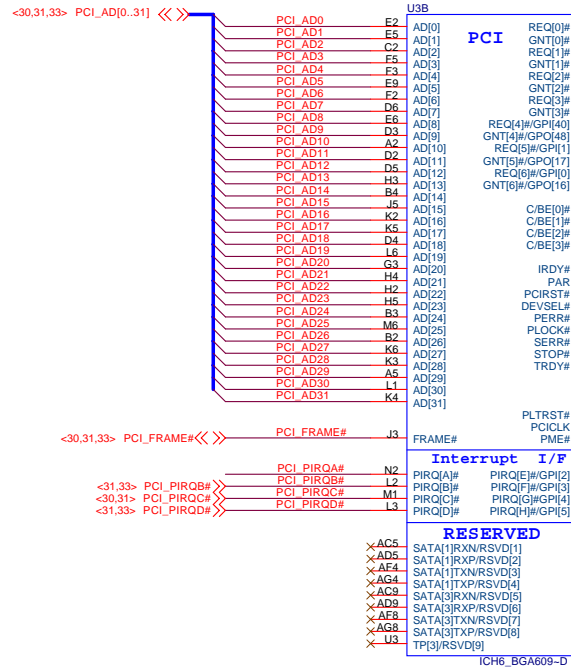
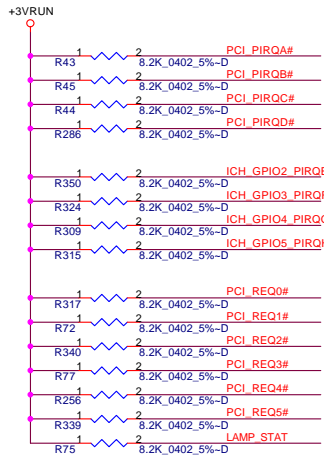
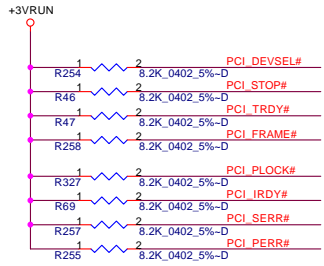

PROPRIETARY NOTE: THIS SHEET OF ENGINEERING DRAWINGS AND SPECIFICATIONS CONTAINS CONFIDENTIAL TRADE SECRET AND OTHER PROPRIETARY INFORMATION OF DELL INC. ("DELL"). THIS DOCUMENT MAY NOT BE REPRODUCED OR COPIED WITHOUT THE EXPRESS WRITTEN AUTHORIZATION OF DELL. IN ADDITION, NEITHER THIS SHEET NOR THE INFORMATION IT CONTAINS MAY BE USED BY OR DISCLOSED TO ANY THIRD PARTY WITHOUT DELL'S EXPRESS WRITTEN CONSENT.

			Compal Electronics, Inc.	
			Title ICH6(1/4)	
Size	Document Number			Rev
	TOBAGO-LA2151			0.6
Date:	Monday, October 18, 2004	Sheet	21	of 51

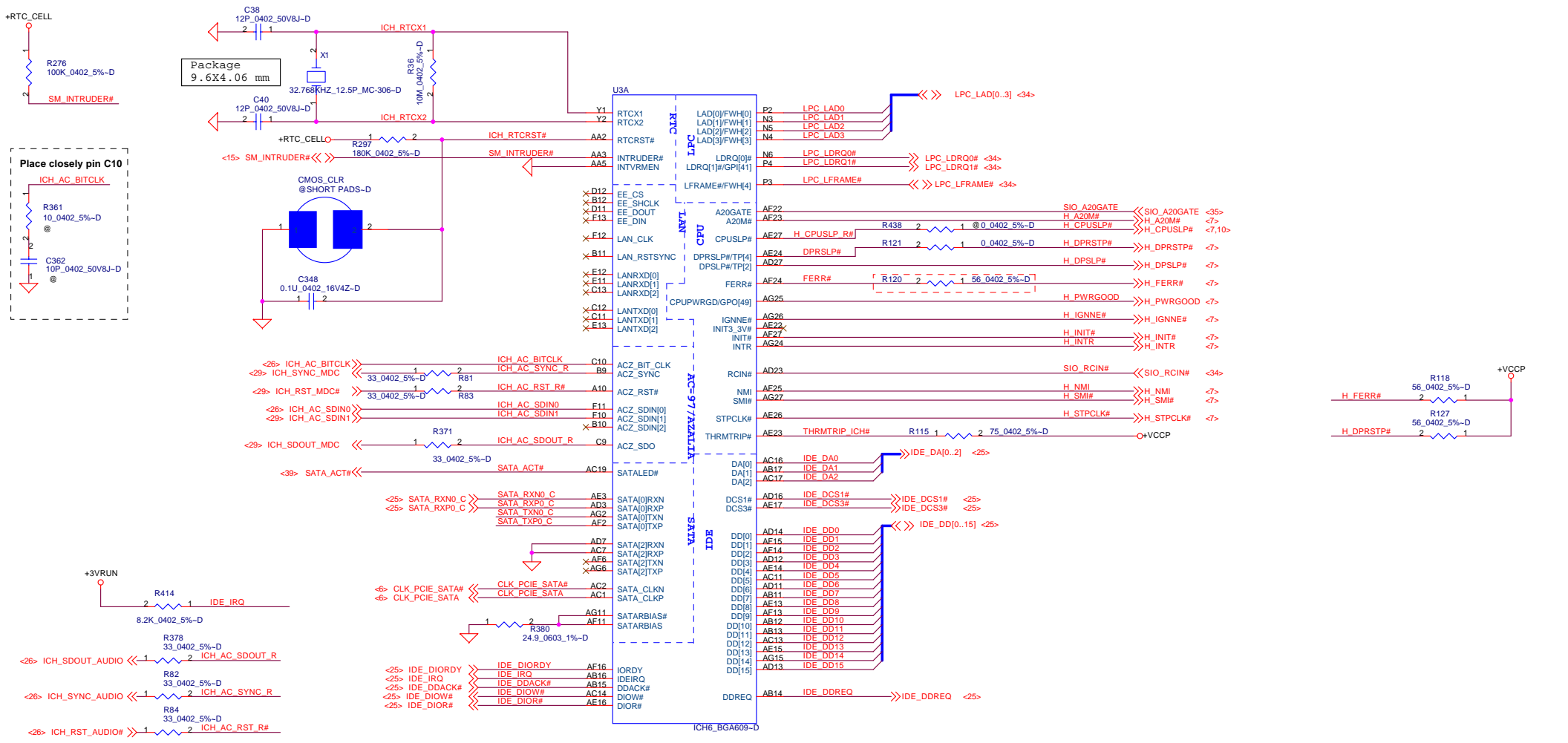

Place closely pin C10

Place near ICH6 side.

DELL CONFIDENTIAL/PROPRIETARY

Compal Electronics, Inc.

Title			
ICH6(2/4)			
Size	Document Number	Rev	
	TOBAGO-LA2151	0.6	
Date:	Monday, October 18, 2004	Sheet	22 of 51

PROPRIETARY NOTE: THIS SHEET OF ENGINEERING DRAWING AND SPECIFICATIONS CONTAINS CONFIDENTIAL TRADE SECRET AND OTHER PROPRIETARY INFORMATION OF DELL INC. ('DELL'). THIS DOCUMENT MAY NOT BE TRANSFERRED OR COPIED WITHOUT THE EXPRESS WRITTEN AUTHORIZATION OF DELL. IN ADDITION, NEITHER THIS SHEET NOR THE INFORMATION IT CONTAINS MAY BE USED BY OR DISCLOSED TO ANY THIRD PARTY WITHOUT DELL'S EXPRESS WRITTEN CONSENT.

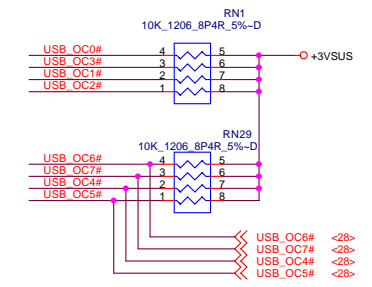
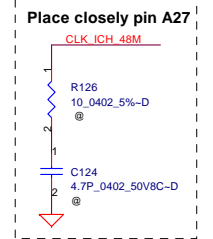
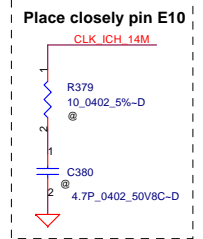
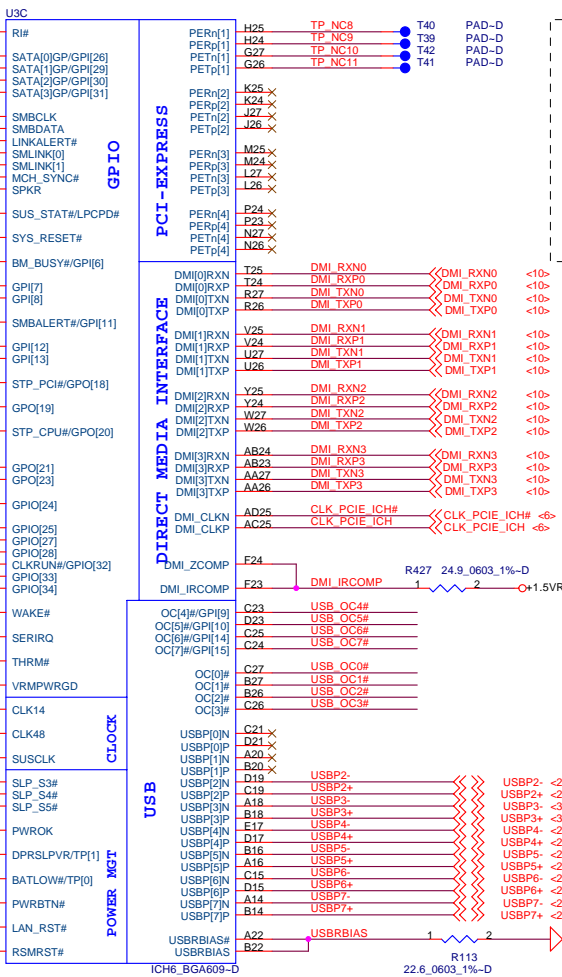
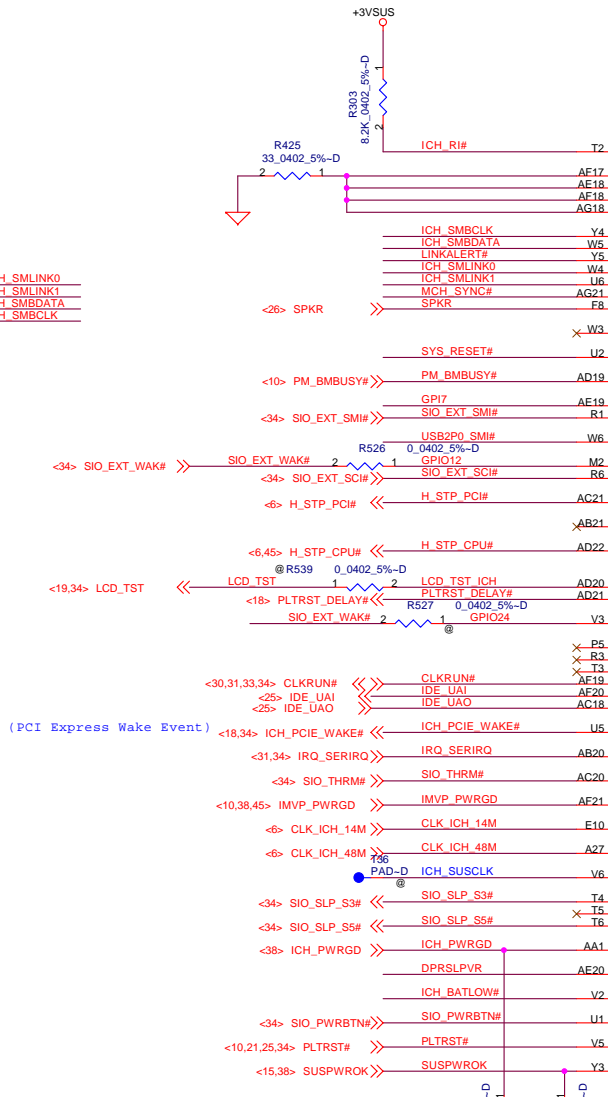
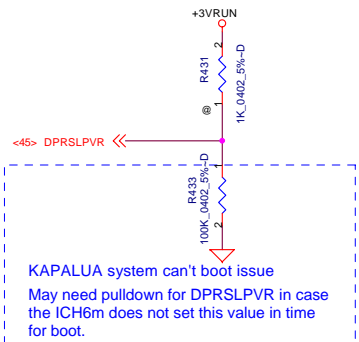
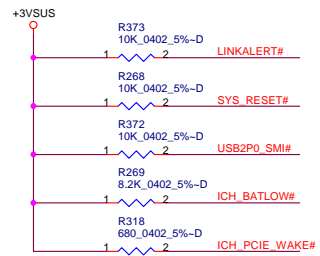
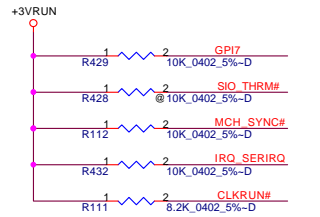
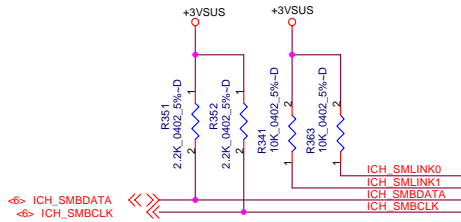

DELL CONFIDENTIAL/PROPRIETARY

Compal Electronics, Inc.

Title		ICH6(3/4)	
Size	Document Number	TOBAGO-LA2151	
Date	Wednesday, November 03, 2004	Sheet	23 of 51

PROPRIETARY NOTE: THIS SHEET OF ENGINEERING DRAWING AND SPECIFICATIONS CONTAINS CONFIDENTIAL TRADE SECRET AND OTHER PROPRIETARY INFORMATION OF DELL INC. ("DELL"). THIS DOCUMENT MAY NOT BE TRANSMITTED OR COPIED WITHOUT THE EXPRESS WRITTEN AUTHORIZATION OF DELL. IN ADDITION, NEITHER THIS SHEET NOR THE INFORMATION IT CONTAINS MAY BE USED BY OR DISCLOSED TO ANY THIRD PARTY WITHOUT DELL'S EXPRESS WRITTEN CONSENT.



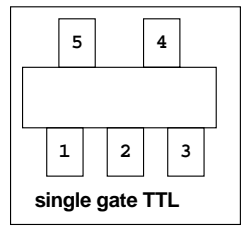
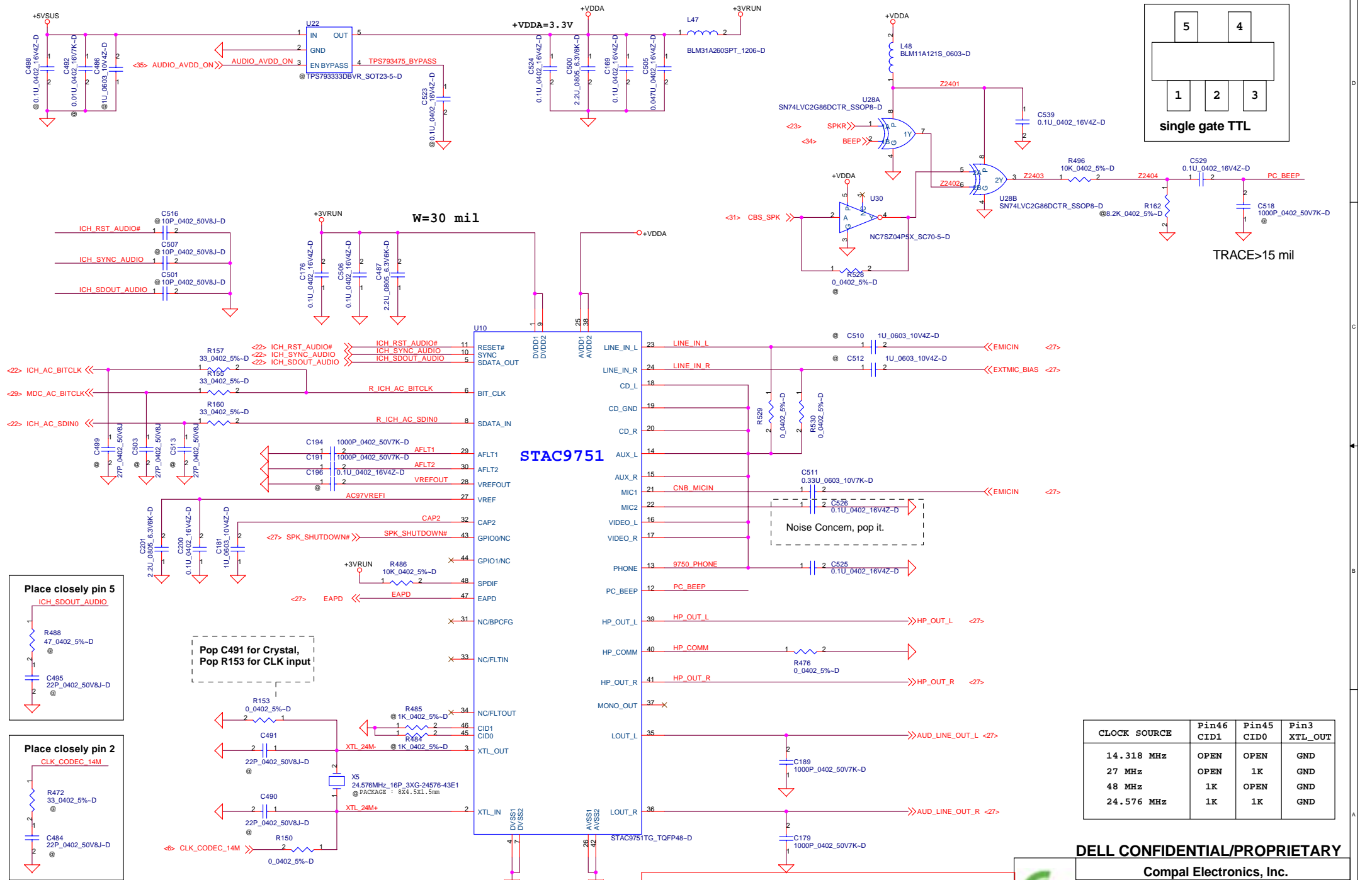

TRACE > 15 mil

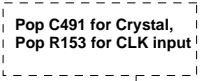
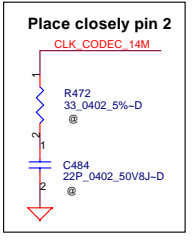
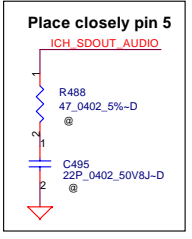

CLOCK SOURCE	Pin46 CID1	Pin45 CID0	Pin3 XTL_OUT
14.318 MHz	OPEN	OPEN	GND
27 MHz	OPEN	1K	GND
48 MHz	1K	OPEN	GND
24.576 MHz	1K	1K	GND

PROPRIETARY NOTE: THIS SHEET OF ENGINEERING DRAWING AND SPECIFICATIONS CONTAINS CONFIDENTIAL TRADE SECRET AND OTHER PROPRIETARY INFORMATION OF DELL INC. ('DELL'). THIS DOCUMENT MAY NOT BE TRANSFERRED OR COPIED WITHOUT THE EXPRESS WRITTEN AUTHORIZATION OF DELL. IN ADDITION, NEITHER THIS SHEET NOR THE INFORMATION IT CONTAINS MAY BE USED BY OR DISCLOSED TO ANY THIRD PARTY WITHOUT DELL'S EXPRESS WRITTEN CONSENT.



DELL CONFIDENTIAL/PROPRIETARY

Compal Electronics, Inc.

Title			Rev
AC97 Codec			0.6
Size	Document Number	TOBAGO-LA2151	
Date:	Monday, October 18, 2004	Sheet	26 of 51

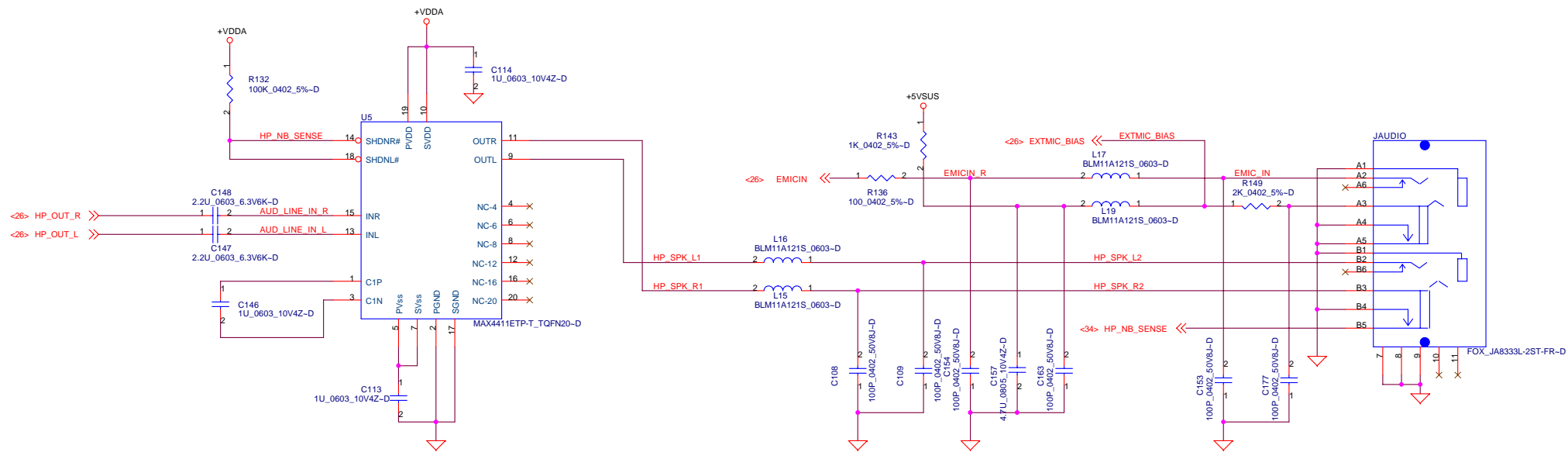

Speaker Connector

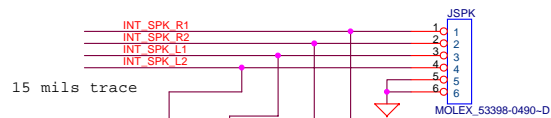

LINE OUT

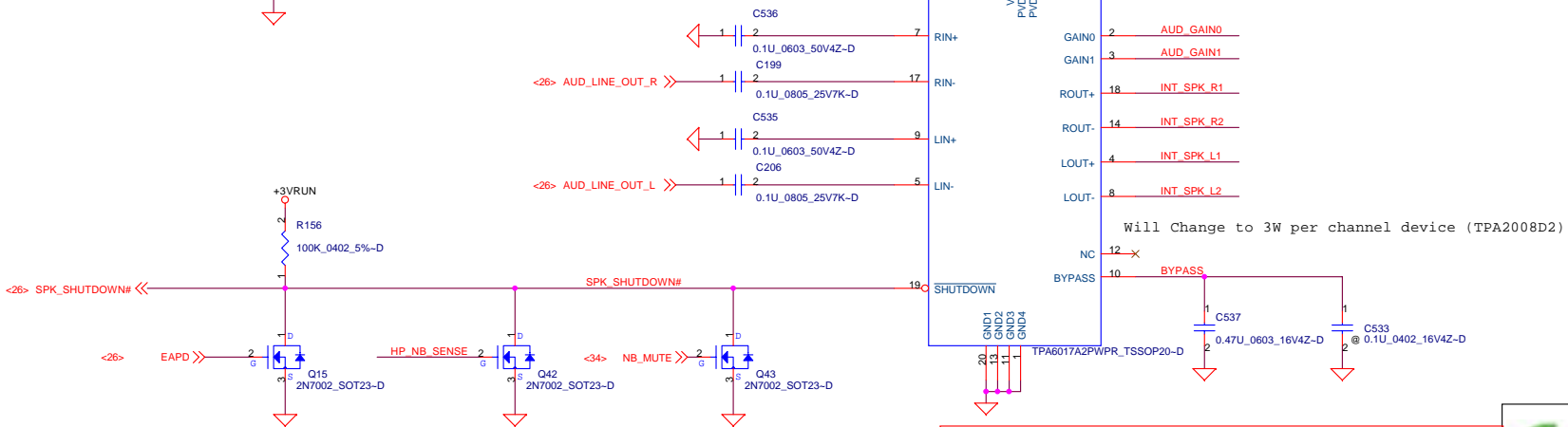
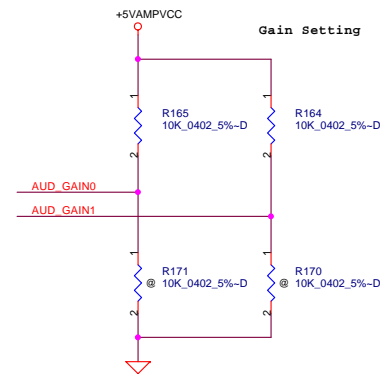
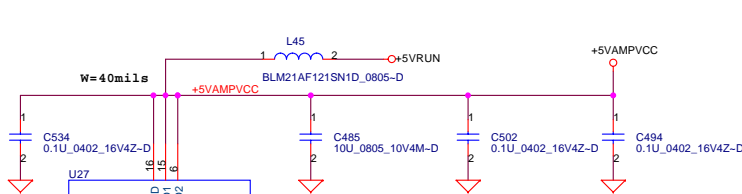

Will Change to 3W per channel device (TPA2008D2)

GAIN0	GAIN1	AV (inv)	INPUT IMPEDANCE
0	0	6dB	90K ohm
0	1	10dB	70K ohm
1	0	15.6dB	45K ohm
1	1	21.6dB	25K ohm

PROPRIETARY NOTE: THIS SHEET OF ENGINEERING DRAWING AND SPECIFICATIONS CONTAINS CONFIDENTIAL TRADE SECRET AND OTHER PROPRIETARY INFORMATION OF DELL INC. ("DELL"). THIS DOCUMENT MAY NOT BE TRANSMITTED OR COPIED WITHOUT THE EXPRESS WRITTEN AUTHORIZATION OF DELL. IN ADDITION, NEITHER THIS SHEET NOR THE INFORMATION IT CONTAINS MAY BE USED BY OR DISCLOSED TO ANY THIRD PARTY WITHOUT DELL'S EXPRESS WRITTEN CONSENT.



DELL CONFIDENTIAL/PROPRIETARY

Compal Electronics, Inc.

AMP and PHONE JACK

Title: **TOBAGO-LA2151**
 Size: Document Number
 Date: Monday, October 18, 2004
 Sheet 27 of 51
 Rev 0.6

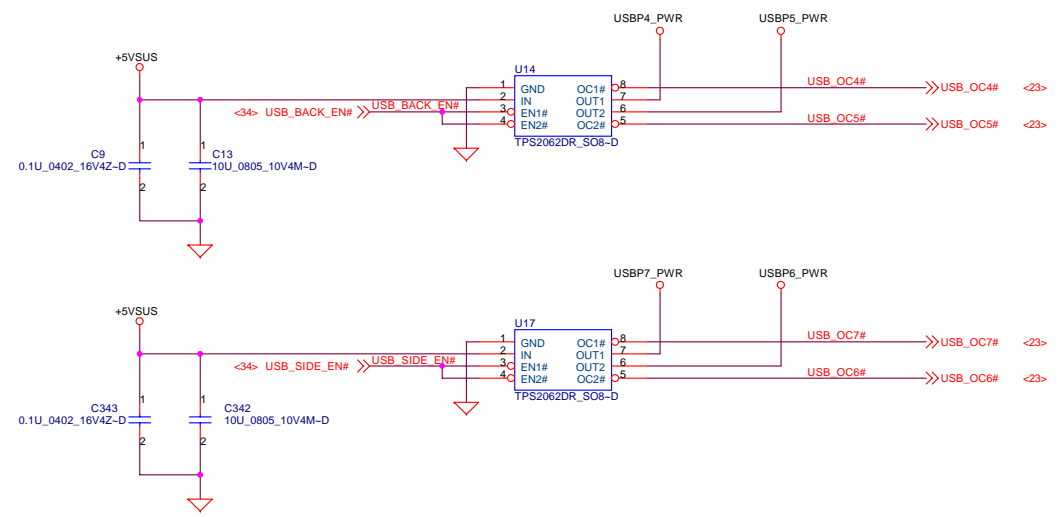
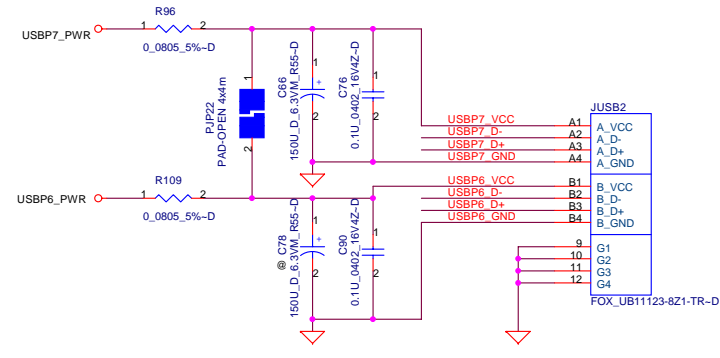
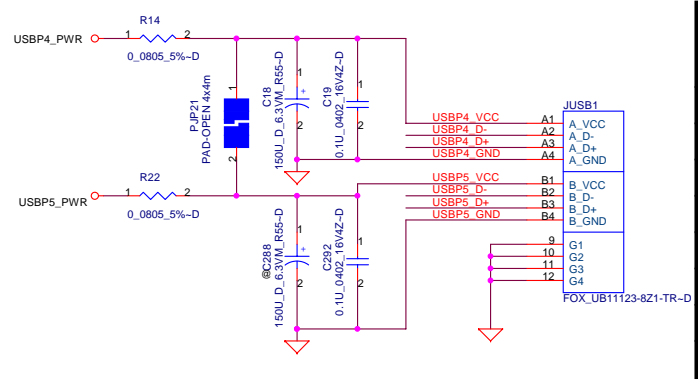
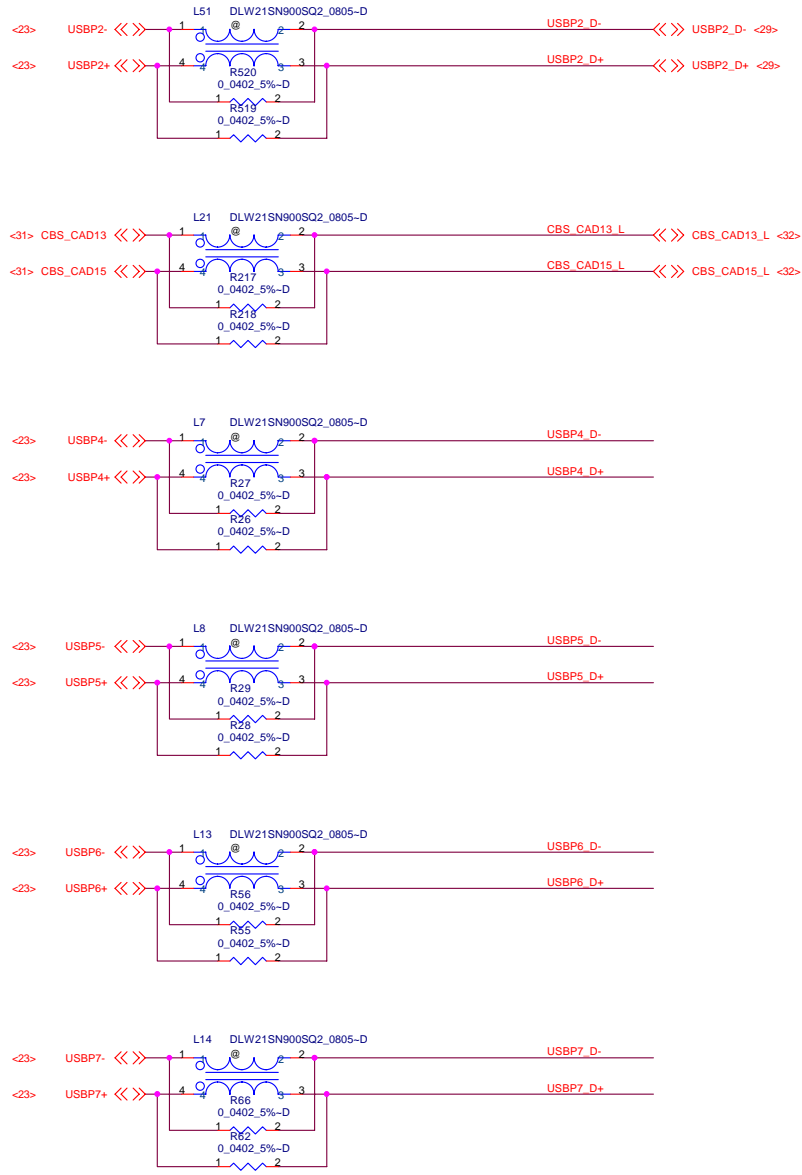

USB PORT#	DESTINATION
0	Reserve
1	Reserve
2	BlueTooth
3	NEW Connector
4	JUSB1 (UP)
5	JUSB1 (LOW)
6	JUSB2 (LOW)
7	JUSB2 (UP)

PROPRIETARY NOTE: THIS SHEET OF ENGINEERING DRAWING AND SPECIFICATIONS CONTAINS CONFIDENTIAL TRADE SECRET AND OTHER PROPRIETARY INFORMATION OF DELL INC. ("DELL"). THIS DOCUMENT MAY NOT BE TRANSMITTED OR COPIED WITHOUT THE EXPRESS WRITTEN AUTHORIZATION OF DELL. IN ADDITION, NEITHER THIS SHEET NOR THE INFORMATION IT CONTAINS MAY BE USED BY OR DISCLOSED TO ANY THIRD PARTY WITHOUT DELL'S EXPRESS WRITTEN CONSENT.



DELL CONFIDENTIAL/PROPRIETARY

Compal Electronics, Inc.

Title			Rev 0.6
Size			
Document Number			Sheet 28 of 51
TOBAGO-LA2151			
Date:	Monday, October 18, 2004		

LCM & Direct play SW & T PAD

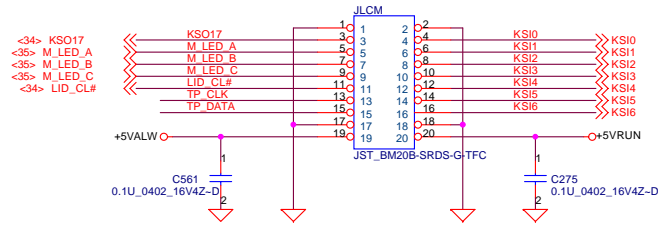

0402 Resistor reserve for ESD

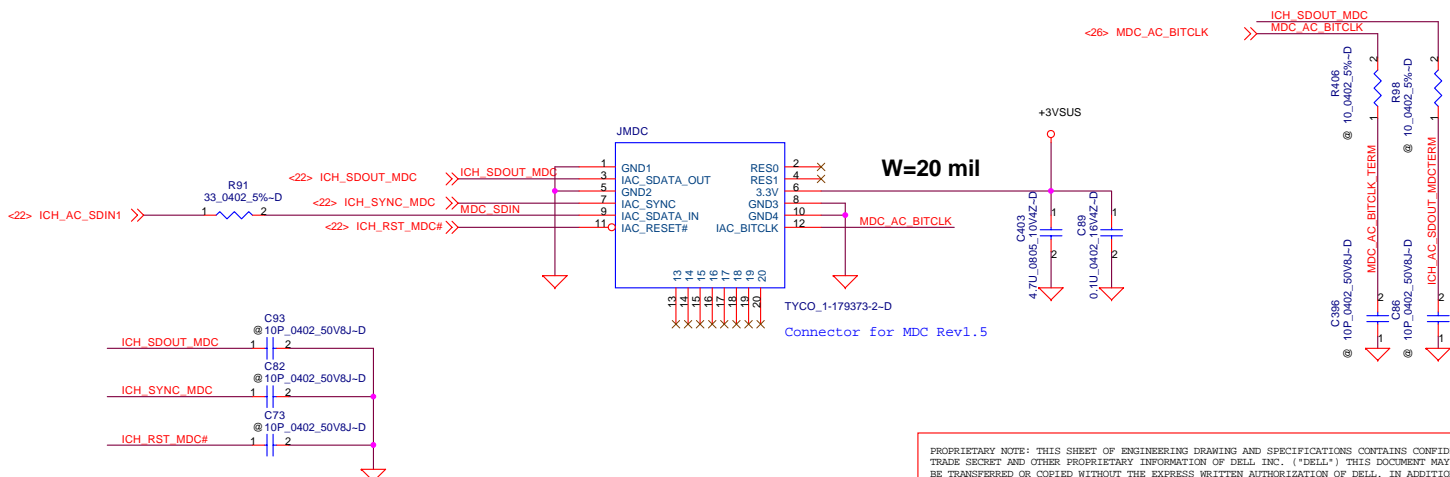
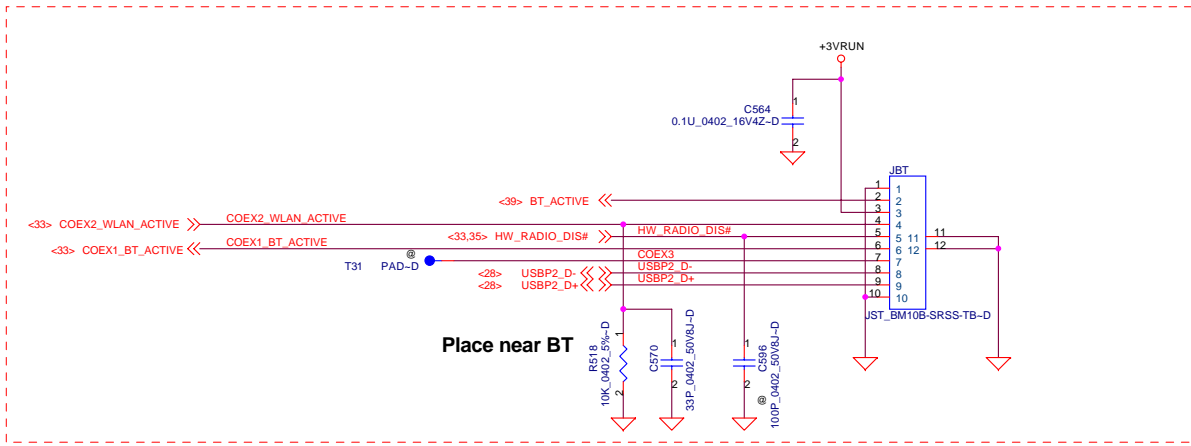
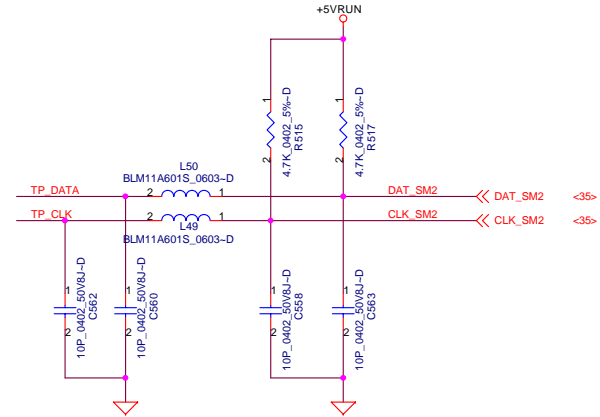

New MDC connector.

1	GND	RES	2
3	IAC_SDATA0	RES	4
5	GND	3.3V	6
7	IAC_SYNC	GND	8
9	IAC_SDATAIN	GND	10
11	IAC_RESET#	IAC_BITCLK	12

PROPRIETARY NOTE: THIS SHEET OF ENGINEERING DRAWING AND SPECIFICATIONS CONTAINS CONFIDENTIAL TRADE SECRET AND OTHER PROPRIETARY INFORMATION OF DELL INC. ("DELL"). THIS DOCUMENT MAY NOT BE TRANSMITTED OR COPIED WITHOUT THE EXPRESS WRITTEN AUTHORIZATION OF DELL. IN ADDITION, NEITHER THIS SHEET NOR THE INFORMATION IT CONTAINS MAY BE USED BY OR DISCLOSED TO ANY THIRD PARTY WITHOUT DELL'S EXPRESS WRITTEN CONSENT.



DELL CONFIDENTIAL/PROPRIETARY

Compal Electronics, Inc.

BT PORT and MDC

TOBAGO-LA2151

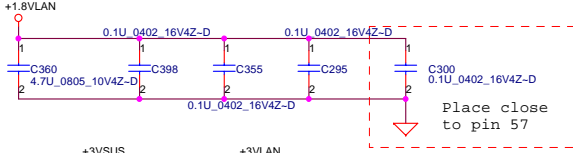
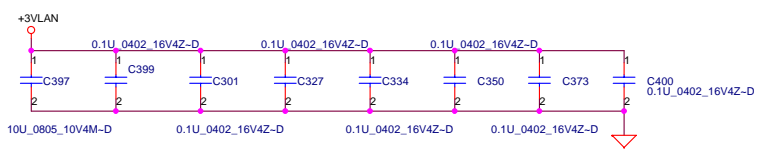

WLAN	LOM	LED (JP28)
WLAN_LINK_80211A	LINK_LED100#	ORANGE (100M)
WLAN_LINK_10_LDE	LINK_LED10#	GREEN (10M)
WLAN_ACT_LED	ACTLED#	YELLOW
WLAN_LINK_80211A	NC	ORANGE/GREEN
WLAN_LINK_10_LDE		

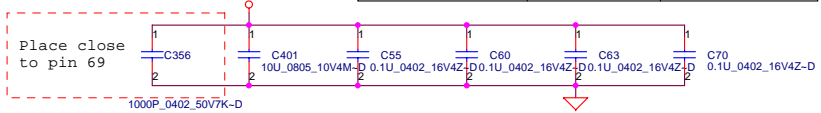
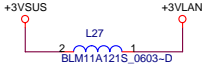

<21,31,33> PCI_AD[0..31] << PCI_AD[0..31]

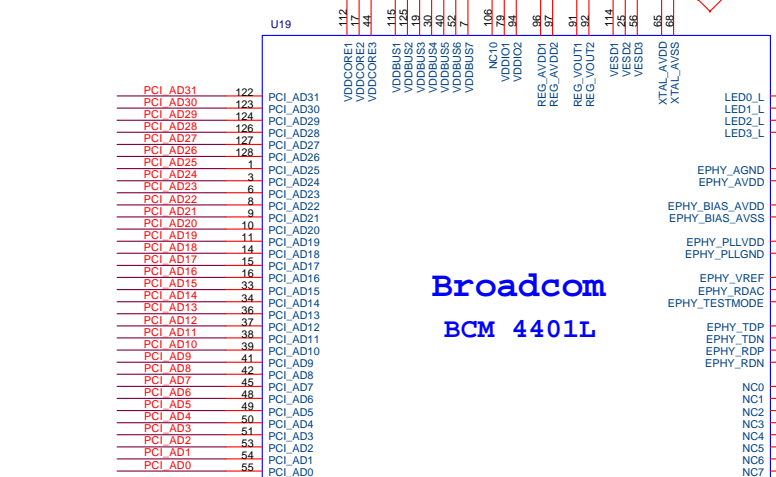

**Broadcom
BCM 4401L**

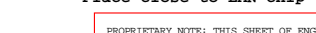
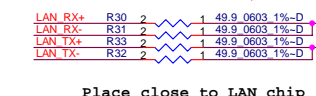
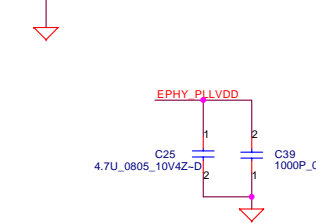
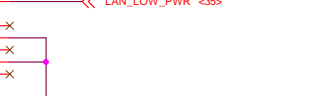
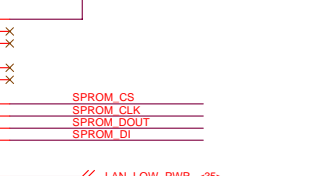
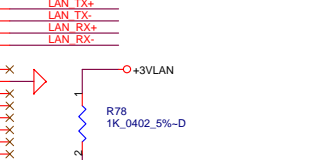
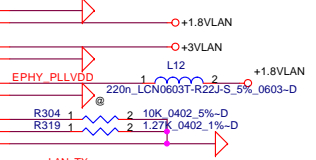
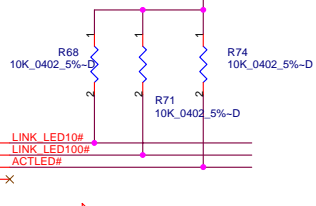
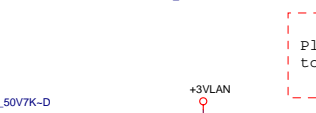
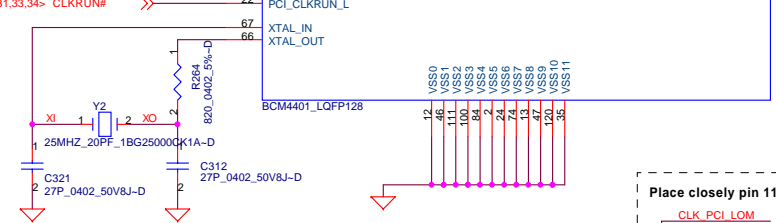
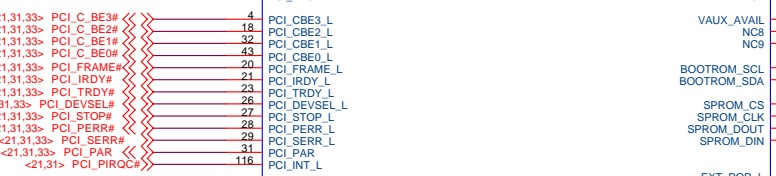

Place close to LAN chip

PROPRIETARY NOTE: THIS SHEET OF ENGINEERING DRAWINGS AND SPECIFICATIONS CONTAINS CONFIDENTIAL TRADE SECRET AND OTHER PROPRIETARY INFORMATION OF DELL INC. ("DELL") THIS DOCUMENT MAY NOT BE TRANSMITTED OR COPIED WITHOUT THE EXPRESS WRITTEN AUTHORIZATION OF DELL. IN ADDITION, NEITHER THIS SHEET NOR THE INFORMATION IT CONTAINS MAY BE USED BY OR DISCLOSED TO ANY THIRD PARTY WITHOUT DELL'S EXPRESS WRITTEN CONSENT.

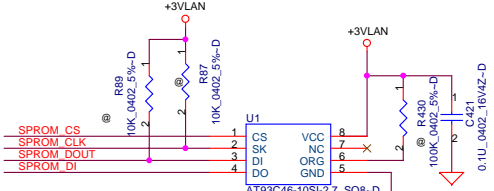

	SPROM_DOUT	SPROM_CLK
1Kb	None	None
4Kb	10K Pullup	None
16Kb	None	10K Pullup

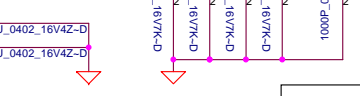
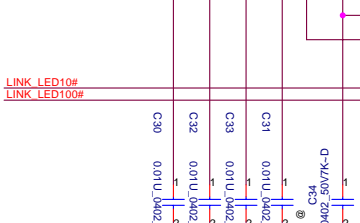
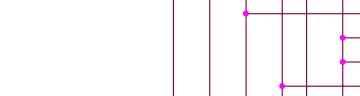
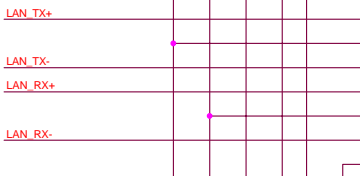
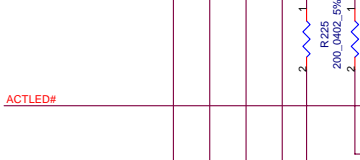

Place close to LAN chip

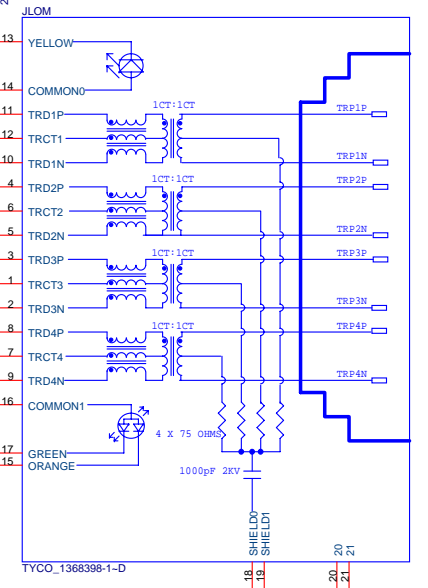

DELL CONFIDENTIAL/PROPRIETARY

Compal Electronics, Inc.

BROADCOM 4401L LAN

TOBAGO-LA2151

Monday, October 18, 2004 Sheet 30 of 51

<21,30,33> PCI_AD[0..31] <<>

- PCI_AD31 M2
- PCI_AD30 M1
- PCI_AD29 N5
- PCI_AD28 N4
- PCI_AD27 N2
- PCI_AD26 N1
- PCI_AD25 P5
- PCI_AD24 P4
- PCI_AD23 R4
- PCI_AD22 R2
- PCI_AD20 T2
- PCI_AD19 T1
- PCI_AD18 U2
- PCI_AD17 U1
- PCI_AD16 V1
- PCI_AD15 T7
- PCI_AD14 V7
- PCI_AD13 W7
- PCI_AD12 R8
- PCI_AD11 T8
- PCI_AD10 V8
- PCI_AD9 W8
- PCI_AD8 V8
- PCI_AD7 V8
- PCI_AD6 W8
- PCI_AD5 T11
- PCI_AD4 V11
- PCI_AD3 W11
- PCI_AD2 T12
- PCI_AD1 V12
- PCI_AD0 W12

R5C841

- CAD31/CDATA10 B19
- CAD30/CDATA9 C18
- CAD29/CDATA1 D19
- CAD28/CDATA8 E18
- CAD27/CDATA7 F18
- CAD26/CDATA6 G18
- CAD25/CADR1 F18
- CAD24/CADR2 F15
- CAD23/CADR3 G15
- CAD22/CADR4 G15
- CAD21/CADR5 H18
- CAD20/CADR6 H15
- CAD19/CADR25 J16
- CAD18/CADR7 J16
- CAD17/CADR24 J15
- CAD16/CADR17 P16
- CAD15/IOWR# P19
- CAD14/CADR8 P18
- CAD13/IO# P18
- CAD12/CADR11 P18
- CAD11/OE# T18
- CAD10/CE2# T18
- CAD9/CADR10 U19
- CAD8/CDATA15 U18
- CAD7/CDATA7 W17
- CAD6/CDATA13 W16
- CAD5/CDATA6 W16
- CAD4/CDATA12 V16
- CAD3/CDATA5 W15
- CAD2/CDATA11 W15
- CAD1/CDATA4 T15
- CAD0/CDATA3 R14

- CBS_CAD31 <-32>
- CBS_CAD30 <-32>
- CBS_CAD29 <-32>
- CBS_CAD28 <-32>
- CBS_CAD27 <-32>
- CBS_CAD26 <-32>
- CBS_CAD25 <-32>
- CBS_CAD24 <-32>
- CBS_CAD23 <-32>
- CBS_CAD22 <-32>
- CBS_CAD21 <-32>
- CBS_CAD20 <-32>
- CBS_CAD19 <-32>
- CBS_CAD18 <-32>
- CBS_CAD17 <-32>
- CBS_CAD16 <-32>
- CBS_CAD15 <-28>
- CBS_CAD14 <-32>
- CBS_CAD13 <-28>
- CBS_CAD12 <-28>
- CBS_CAD11 <-32>
- CBS_CAD10 <-32>
- CBS_CAD9 <-32>
- CBS_CAD8 <-32>
- CBS_CAD7 <-32>
- CBS_CAD6 <-32>
- CBS_CAD5 <-32>
- CBS_CAD4 <-32>
- CBS_CAD3 <-32>
- CBS_CAD2 <-32>
- CBS_CAD1 <-32>
- CBS_CAD0 <-32>

<21,30,33> PCI_C_BE3# <<> PCI_C_BE3# P2
 <21,30,33> PCI_C_BE2# <<> PCI_C_BE2# W2
 <21,30,33> PCI_C_BE1# <<> PCI_C_BE1# W6
 <21,30,33> PCI_C_BE0# <<> PCI_C_BE0# T9

<21,30,33> PCI_PAR <<> PCI_PAR V6

<21,30,33> PCI_FRAME# <<> PCI_FRAME# V3
 <21,30,33> PCI_TRDY# <<> PCI_TRDY# W4
 <21,30,33> PCI_IRDY# <<> PCI_IRDY# V4
 <21,30,33> PCI_STOP# <<> PCI_STOP# V6
 <21,30,33> PCI_STOP# <<> PCI_STOP# V6
 <21,30,33> PCI_DEVSEL# <<> PCI_DEVSEL# T5
 <21,30,33> PCI_DEVSEL# <<> PCI_DEVSEL# T5

<21,30,33> PCI_PERR# <<> PCI_PERR# W5
 <21,30,33> PCI_SERR# <<> PCI_SERR# T6

<21> PCI_REQ1# <<> PCI_REQ1# M4
 <21> PCI_GNT1# <<> PCI_GNT1# M5

<6> CLK_PCI_PCM <<> PCI_PCM K1
 <21,30,33> PCI_RST# <<> PCI_RST# L4
 <21,30,33> PCI_RST# <<> PCI_RST# L4
 <21,30,33> CLKRUN# <<> CLKRUN# G2

<21,33> PCI_PIRD# <<> PCI_PIRD# J2
 <21,30> PCI_PIRQ# <<> PCI_PIRQ# K4
 <21,33> PCI_PIRQ# <<> PCI_PIRQ# K2
 <23,34> IRQ_SERIRQ <<> IRQ_SERIRQ H4

+3VSUS <<> UDIO0/SERIRQ# H1
 +3VSUS <<> UDIO1 H2
 +3VSUS <<> UDIO3 H4
 +3VSUS <<> UDIO4 H5
 +3VSUS <<> UDIO5 G1

<30,33,34> SYS_PME# <<> CBS_SPK G4
 <26> CBS_SPK <<> CBS_SPK F2
 <34> CB_HWSPND# <<> CB_HWSPND# F4

+3VSUS <<> R154 1 2 10K 0402 5%-D
 +3VSUS <<> R161 1 2 10K 0402 5%-D
 +3VSUS <<> R477 1 2 10K 0402 5%-D
 +3VSUS <<> R487 1 2 100K 0402 5%-D

<21,30,33,34> CLK_PCI_PCM <<> R163 1 2 @ 0.0402 5%-D
 <21,30,33,34> CLK_PCI_PCM <<> R168 1 2 10K 0402 5%-D

<21,33> PCI_PIRD# <<> R168 1 2 10K 0402 5%-D
 <21,30> PCI_PIRQ# <<> R168 1 2 10K 0402 5%-D
 <21,33> PCI_PIRQ# <<> R168 1 2 10K 0402 5%-D

+3VSUS <<> R154 1 2 10K 0402 5%-D
 +3VSUS <<> R161 1 2 10K 0402 5%-D
 +3VSUS <<> R477 1 2 10K 0402 5%-D
 +3VSUS <<> R487 1 2 100K 0402 5%-D

<30,33,34> SYS_PME# <<> CBS_SPK G4
 <26> CBS_SPK <<> CBS_SPK F2
 <34> CB_HWSPND# <<> CB_HWSPND# F4

+3VSUS <<> R154 1 2 10K 0402 5%-D
 +3VSUS <<> R161 1 2 10K 0402 5%-D
 +3VSUS <<> R477 1 2 10K 0402 5%-D
 +3VSUS <<> R487 1 2 100K 0402 5%-D

<21,30,33,34> CLK_PCI_PCM <<> R163 1 2 @ 0.0402 5%-D
 <21,30,33,34> CLK_PCI_PCM <<> R168 1 2 10K 0402 5%-D

<21,33> PCI_PIRD# <<> R168 1 2 10K 0402 5%-D
 <21,30> PCI_PIRQ# <<> R168 1 2 10K 0402 5%-D
 <21,33> PCI_PIRQ# <<> R168 1 2 10K 0402 5%-D

+3VSUS <<> R154 1 2 10K 0402 5%-D
 +3VSUS <<> R161 1 2 10K 0402 5%-D
 +3VSUS <<> R477 1 2 10K 0402 5%-D
 +3VSUS <<> R487 1 2 100K 0402 5%-D

<30,33,34> SYS_PME# <<> CBS_SPK G4
 <26> CBS_SPK <<> CBS_SPK F2
 <34> CB_HWSPND# <<> CB_HWSPND# F4

+3VSUS <<> R154 1 2 10K 0402 5%-D
 +3VSUS <<> R161 1 2 10K 0402 5%-D
 +3VSUS <<> R477 1 2 10K 0402 5%-D
 +3VSUS <<> R487 1 2 100K 0402 5%-D

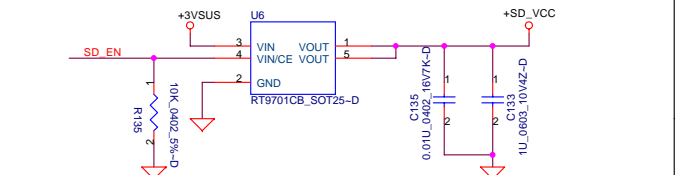
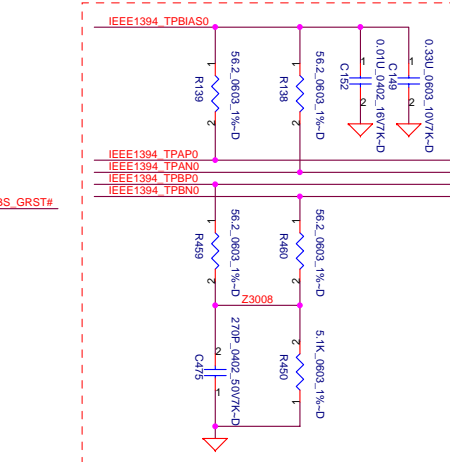
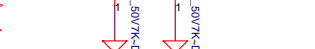
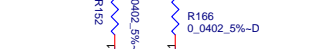
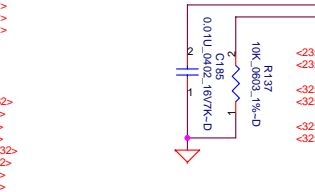
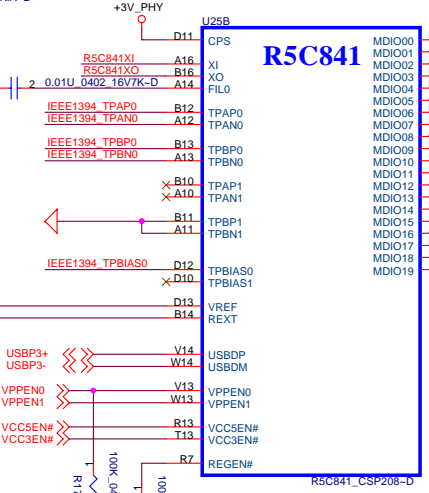
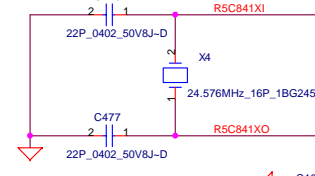

PROPRIETARY NOTE: THIS SHEET OF ENGINEERING DRAWING AND SPECIFICATIONS CONTAINS CONFIDENTIAL TRADE SECRET AND OTHER PROPRIETARY INFORMATION OF DELL INC. ("DELL"). THIS DOCUMENT MAY NOT BE TRANSMITTED OR COPIED WITHOUT THE EXPRESS WRITTEN AUTHORIZATION OF DELL. IN ADDITION, NEITHER THIS SHEET NOR THE INFORMATION IT CONTAINS MAY BE USED BY OR DISCLOSED TO ANY THIRD PARTY WITHOUT DELL'S EXPRESS WRITTEN CONSENT.



DELL CONFIDENTIAL/PROPRIETARY

Compal Electronics, Inc.

CardBus Controller(R5C841)

Title: TOBAGO-LA2151
 Size: Document Number
 Date: Monday, October 18, 2004
 Sheet: 31 of 51
 Rev: 0.6

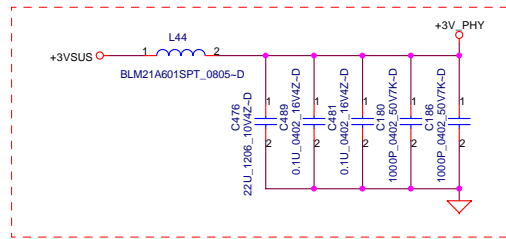
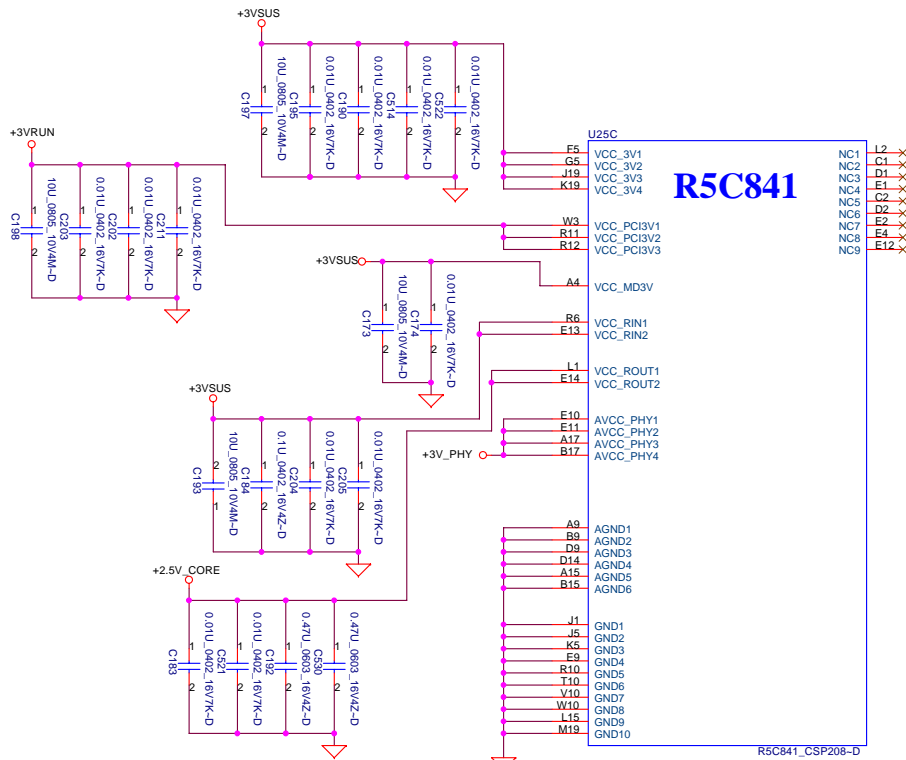

FAN	
Part Number	Description
DC28A00800	FAN SET DAQ20 DC5V AB7405HB-HB3 ADDA

Speak	
Part Number	Description
PK230007700	SPK PACK DAQ20 2W 40HM 18MM P5

PCMCIA BODY	
Part Number	Description
DC00F001700	PCMCIA FOXCONN 1CA415M1-TA 68P

Bluetooth wire set cable	
Part Number	Description
DC025072300	H-CON SET DAL30 MB-B/T-RTC

MDC wire set cable	
Part Number	Description
DC025072400	H-CON SET DAL30 MB-MDC

Media wire set cable	
Part Number	Description
DC025072500	H-CON SET DAL30 MB-MEDIA-TP

T/P FFC cable	
Part Number	Description
NBX08001000	FFC 6P F1.0 PAD=0.7 23mm

RTC BATT	
Part Number	Description
GC20323MX00	BATT CR2032 3V 220MAH MAXXELL

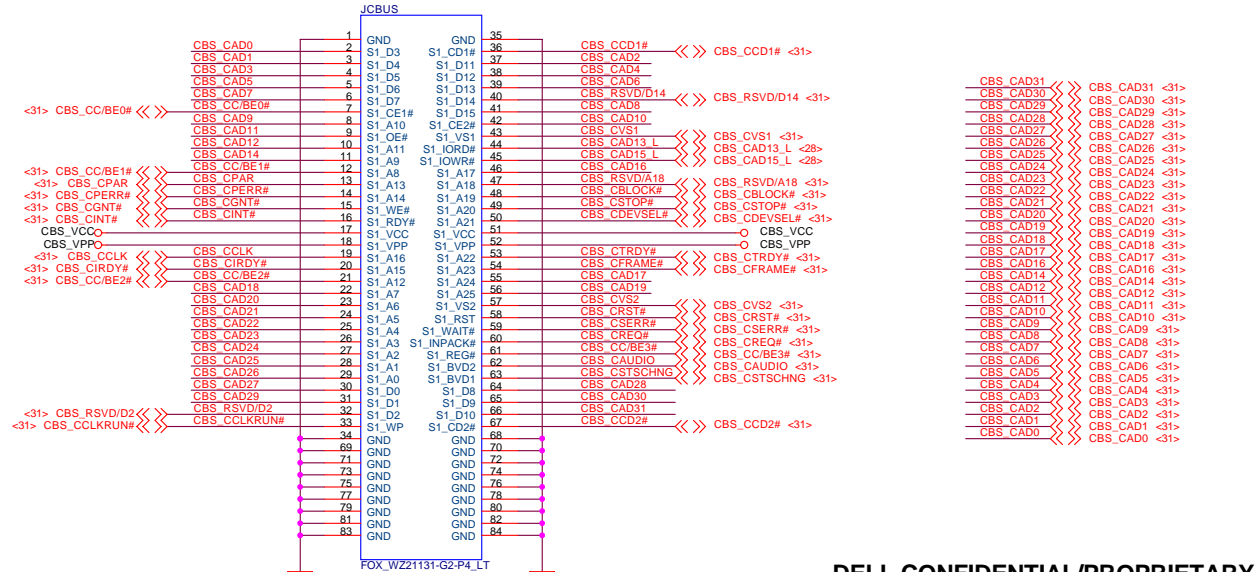
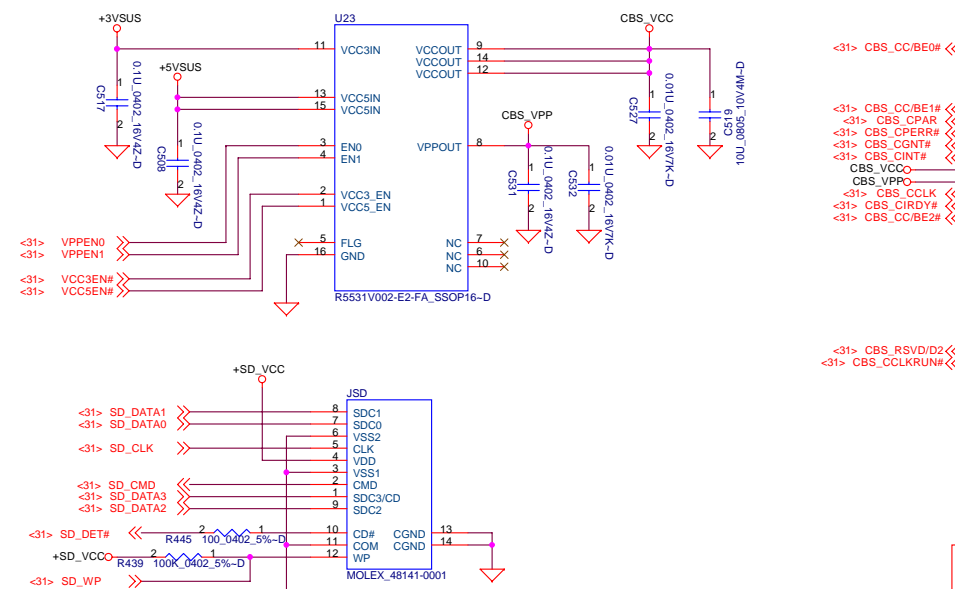

PROPRIETARY NOTE: THIS SHEET OF ENGINEERING DRAWING AND SPECIFICATIONS CONTAINS CONFIDENTIAL TRADE SECRET AND OTHER PROPRIETARY INFORMATION OF DELL INC. ("DELL"). THIS DOCUMENT MAY NOT BE TRANSMITTED OR COPIED WITHOUT THE EXPRESS WRITTEN AUTHORIZATION OF DELL. IN ADDITION, NEITHER THIS SHEET NOR THE INFORMATION IT CONTAINS MAY BE USED BY OR DISCLOSED TO ANY THIRD PARTY WITHOUT DELL'S EXPRESS WRITTEN CONSENT.

DELL CONFIDENTIAL/PROPRIETARY

Compal Electronics, Inc.

CardBus/SD card Socket

TOBAGO-LA2151

File: _____
 Size: _____ Document Number: _____
 Date: Monday, October 18, 2004 Sheet 32 of 51

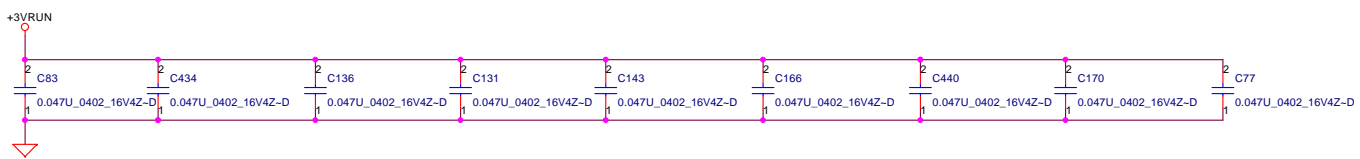
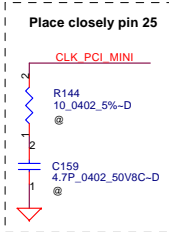
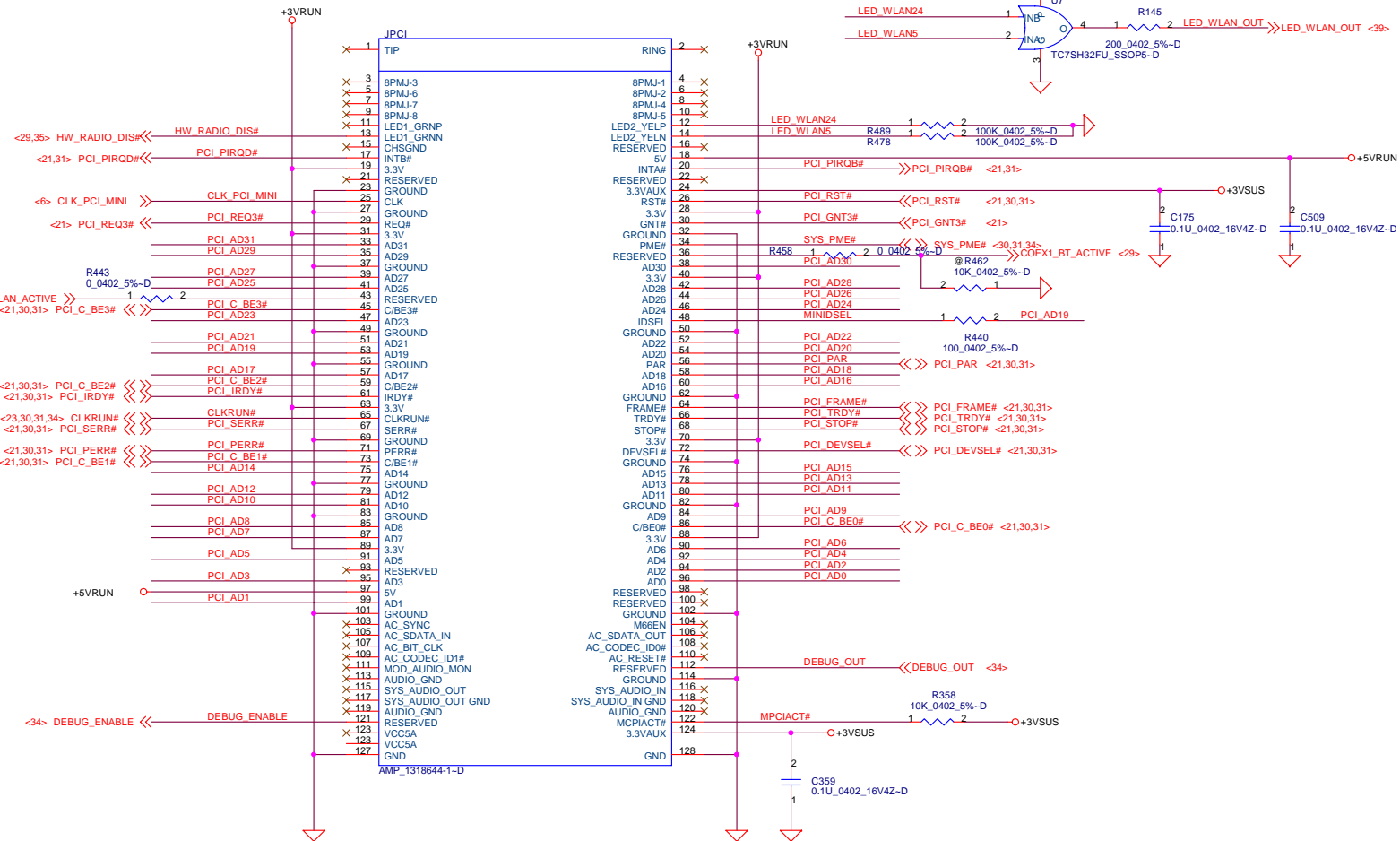
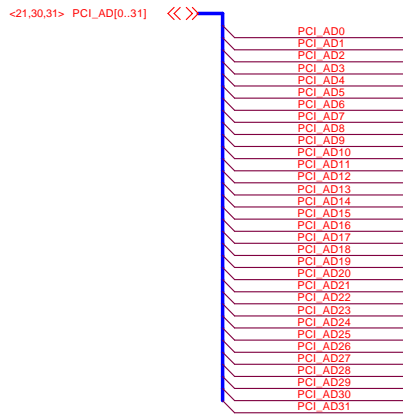

DELL CONFIDENTIAL/PROPRIETARY

Compal Electronics, Inc.



Title			MINIPCI		
Size	Document Number		TOBAGO-LA2151		
Date:	Monday, October 18, 2004	Sheet	33	of	51
					Rev
					0.6

PROPRIETARY NOTE: THIS SHEET OF ENGINEERING DRAWING AND SPECIFICATIONS CONTAINS CONFIDENTIAL TRADE SECRET AND OTHER PROPRIETARY INFORMATION OF DELL INC. ("DELL"). THIS DOCUMENT MAY NOT BE TRANSMITTED OR COPIED WITHOUT THE EXPRESS WRITTEN AUTHORIZATION OF DELL. IN ADDITION, NEITHER THIS SHEET NOR THE INFORMATION IT CONTAINS MAY BE USED BY OR DISCLOSED TO ANY THIRD PARTY WITHOUT DELL'S EXPRESS WRITTEN CONSENT.

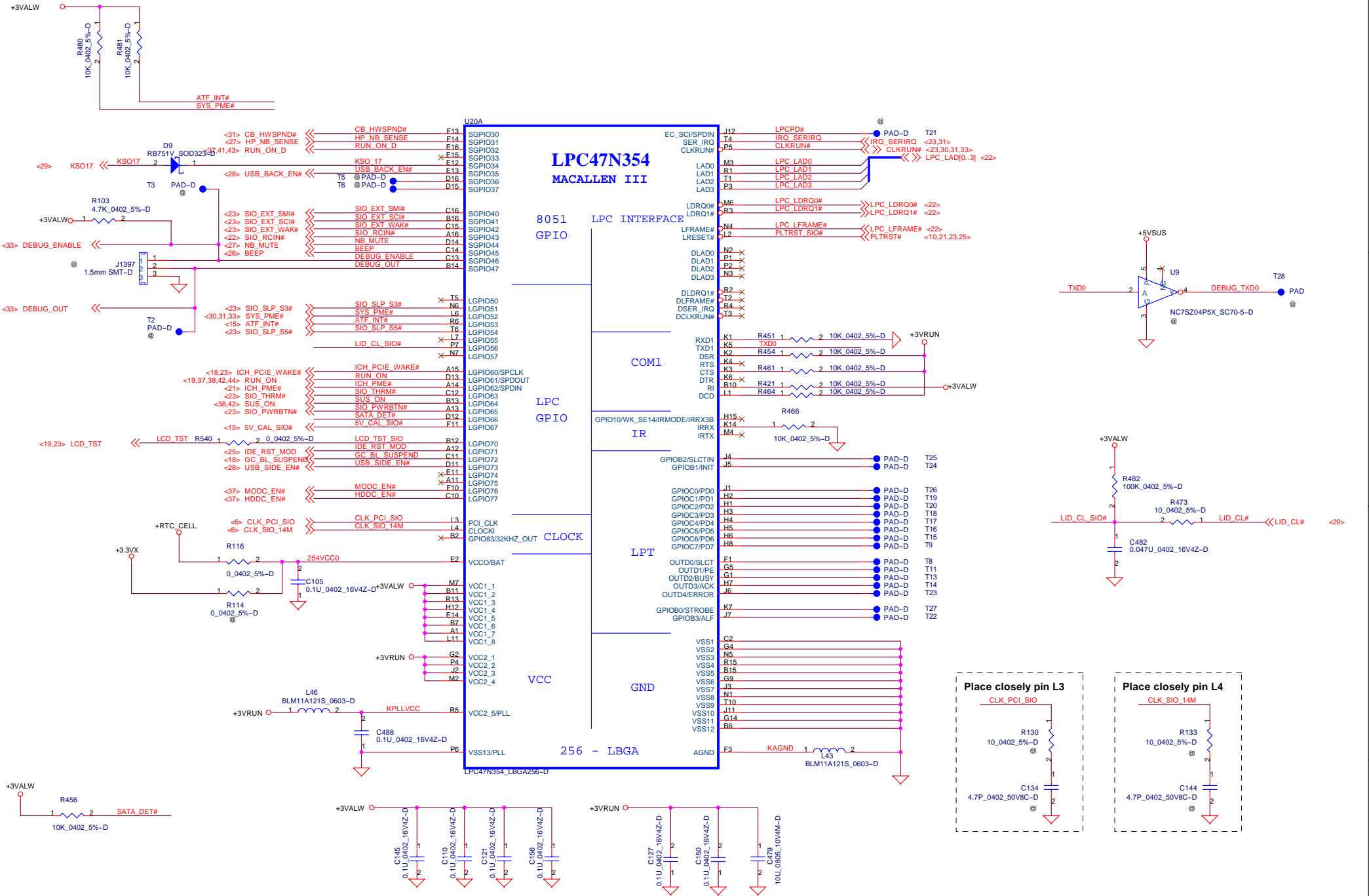

DELL CONFIDENTIAL/PROPRIETARY



Compal Electronics, Inc.	
SIO (1/2)	
Title	
Size	Document Number
TOBAGO-LA2151	
Date:	Monday, October 18, 2004
Sheet	34 of 51
Rev	0.6

PROPRIETARY NOTE: THIS SHEET OF ENGINEERING DRAWING AND SPECIFICATIONS CONTAINS CONFIDENTIAL TRADE SECRET AND OTHER PROPRIETARY INFORMATION OF DELL INC. ("DELL"). THIS DOCUMENT MAY NOT BE TRANSMITTED OR COPIED WITHOUT THE EXPRESS WRITTEN AUTHORIZATION OF DELL. IN ADDITION, NEITHER THIS SHEET NOR THE INFORMATION IT CONTAINS MAY BE USED BY OR DISCLOSED TO ANY THIRD PARTY WITHOUT DELL'S EXPRESS WRITTEN CONSENT.

VGA_IDENTIFY
LOW = Integrated
High = Discrete

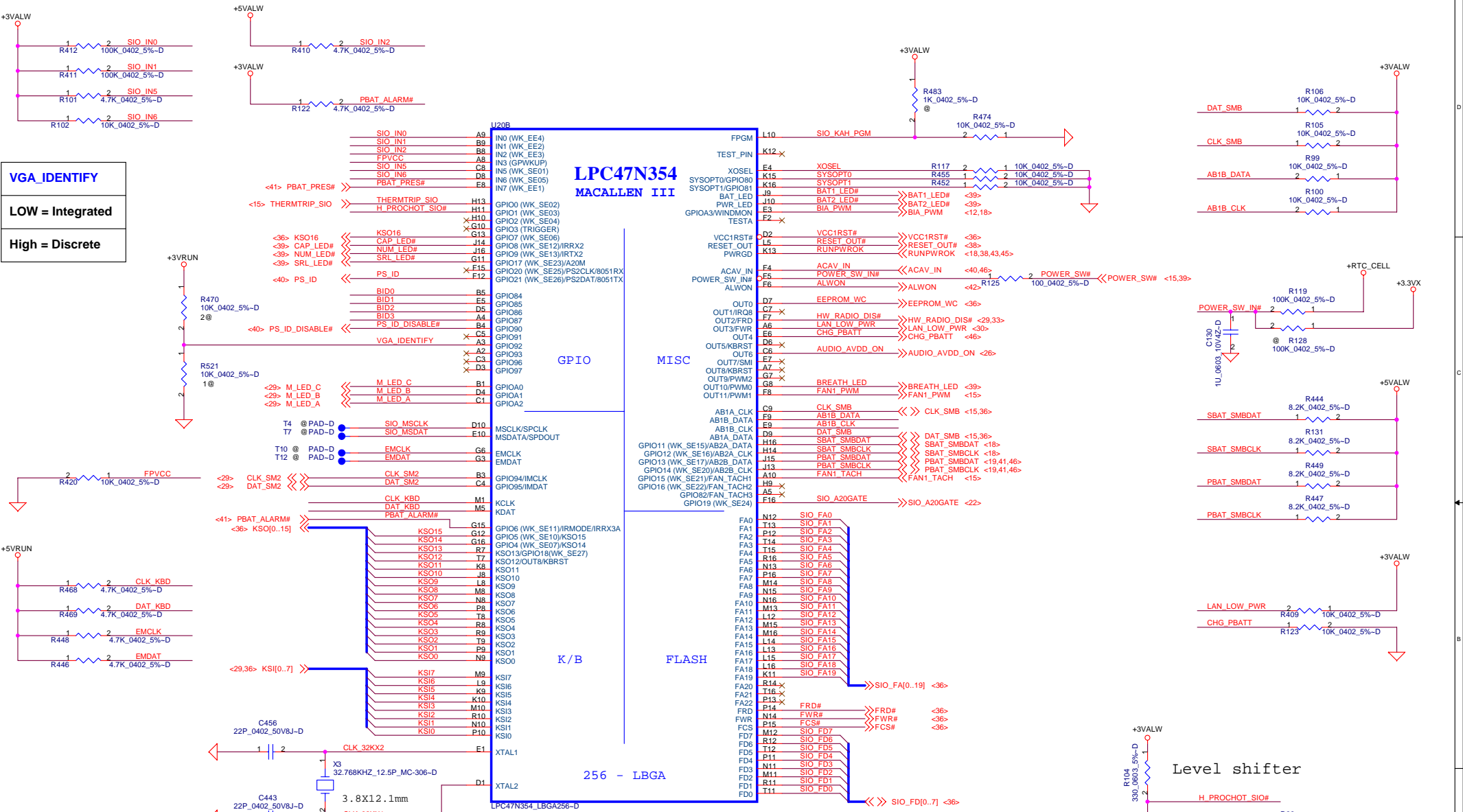

BID3	BID2	BID1	BID0	REV
0	0	0	0	X00
0	0	0	1	X01
0	0	1	0	X02
0	0	1	1	X03
0	1	0	0	X04

PROPRIETARY NOTE: THIS SHEET OF ENGINEERING DRAWING AND SPECIFICATIONS CONTAINS CONFIDENTIAL TRADE SECRET AND OTHER PROPRIETARY INFORMATION OF DELL INC. ("DELL"). THIS DOCUMENT MAY NOT BE TRANSMITTED OR COPIED WITHOUT THE EXPRESS WRITTEN AUTHORIZATION OF DELL. IN ADDITION, NEITHER THIS SHEET NOR THE INFORMATION IT CONTAINS MAY BE USED BY OR DISCLOSED TO ANY THIRD PARTY WITHOUT DELL'S EXPRESS WRITTEN CONSENT.



DELL CONFIDENTIAL/PROPRIETARY

Compal Electronics, Inc.			
SIO (2/2)			
Title	Document Number		
Size	TOBAGO-LA2151		
Date:	Monday, October 18, 2004	Sheet	35 of 51

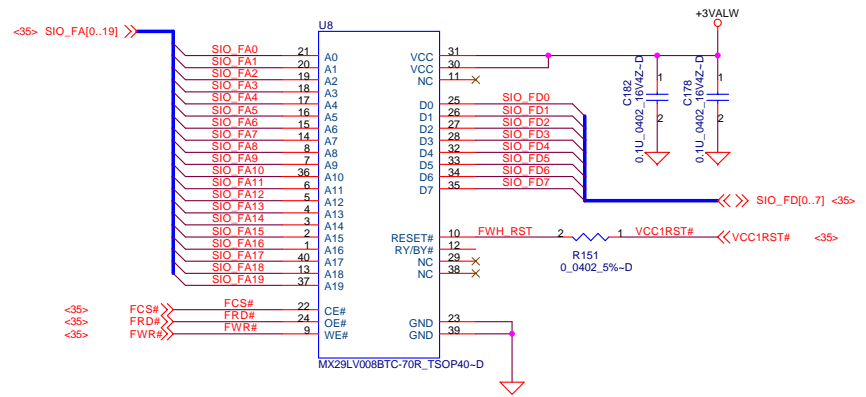
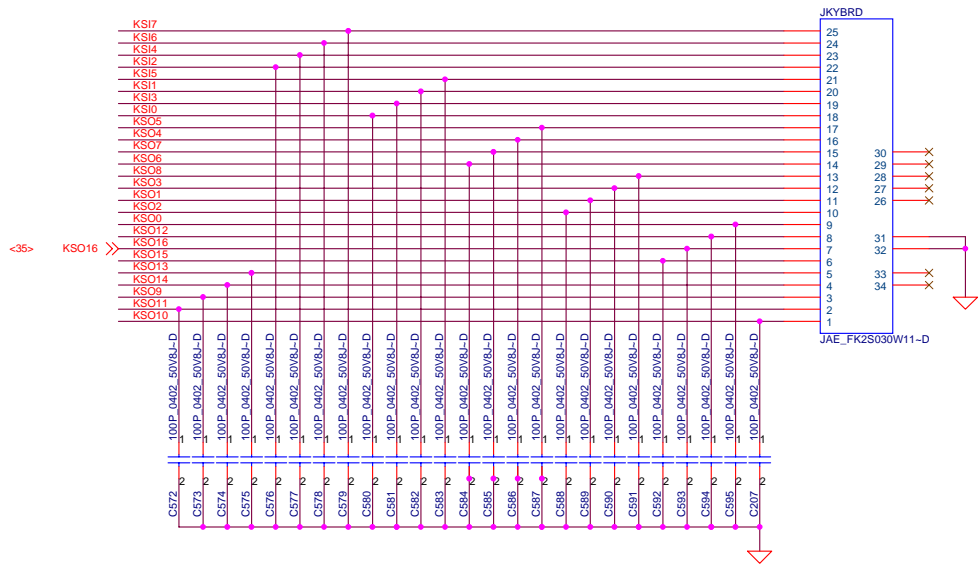
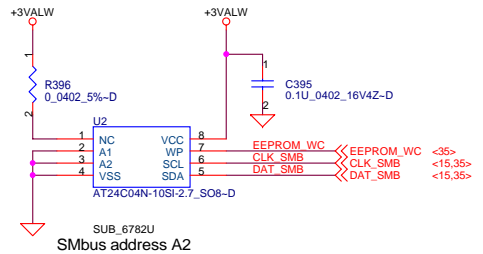
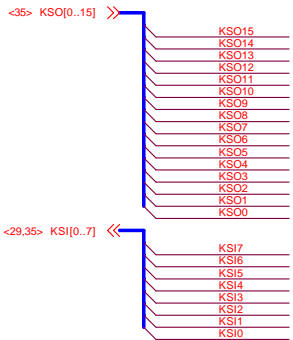

PROPRIETARY NOTE: THIS SHEET OF ENGINEERING DRAWING AND SPECIFICATIONS CONTAINS CONFIDENTIAL TRADE SECRET AND OTHER PROPRIETARY INFORMATION OF DELL INC. ("DELL"). THIS DOCUMENT MAY NOT BE TRANSFERRED OR COPIED WITHOUT THE EXPRESS WRITTEN AUTHORIZATION OF DELL. IN ADDITION, NEITHER THIS SHEET NOR THE INFORMATION IT CONTAINS MAY BE USED BY OR DISCLOSED TO ANY THIRD PARTY WITHOUT DELL'S EXPRESS WRITTEN CONSENT.

DELL CONFIDENTIAL/PROPRIETARY

Compal Electronics, Inc.

INT KB

TOBAGO-LA2151

Date: Monday, October 13, 2004 Sheet 36 of 51

Run Planes Enable

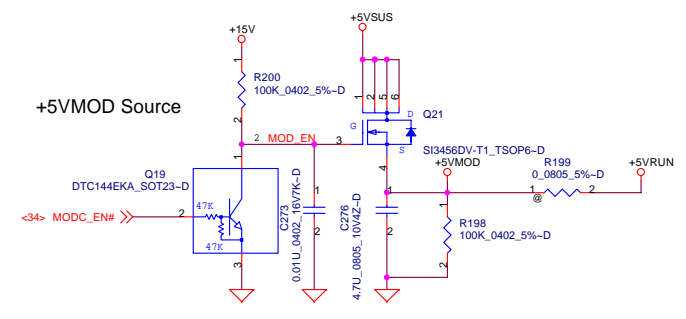
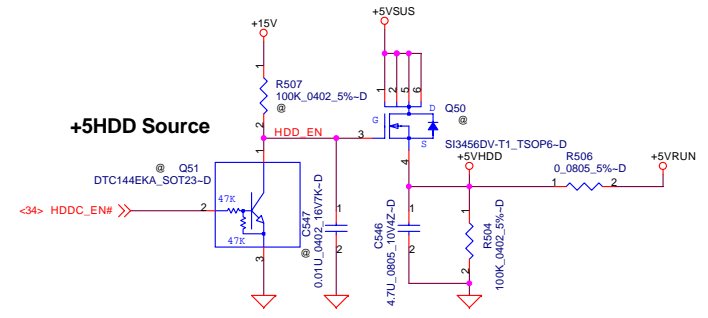
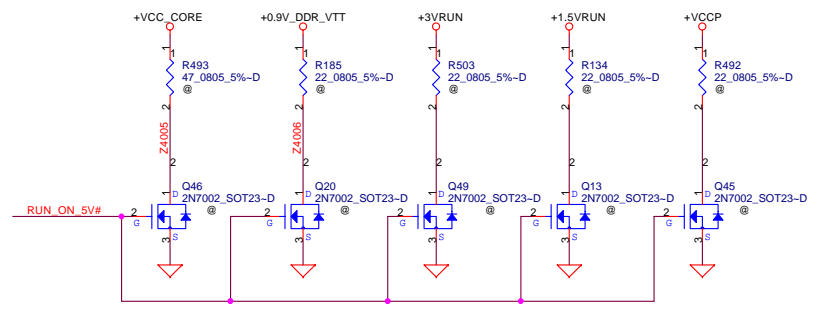
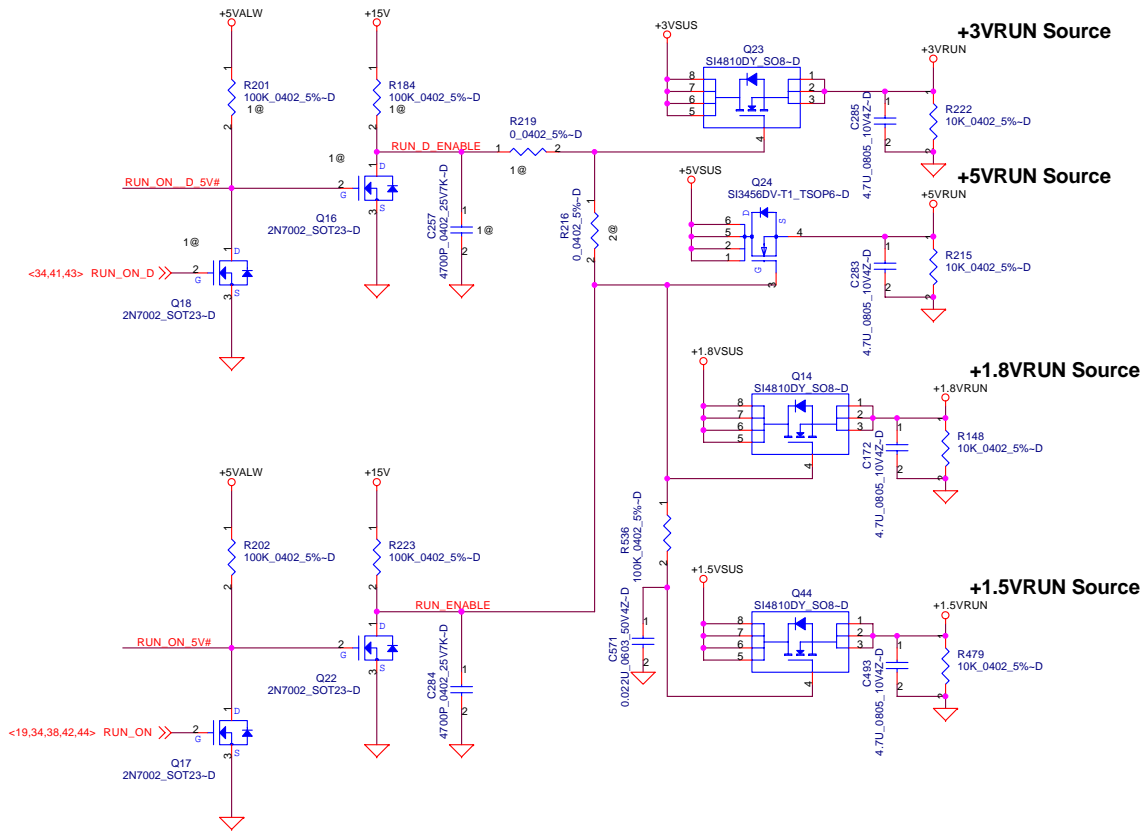

PROPRIETARY NOTE: THIS SHEET OF ENGINEERING DRAWING AND SPECIFICATIONS CONTAINS CONFIDENTIAL TRADE SECRET AND OTHER PROPRIETARY INFORMATION OF DELL INC. ("DELL"). THIS DOCUMENT MAY NOT BE TRANSFERRED OR COPIED WITHOUT THE EXPRESS WRITTEN AUTHORIZATION OF DELL. IN ADDITION, NEITHER THIS SHEET NOR THE INFORMATION IT CONTAINS MAY BE USED BY OR DISCLOSED TO ANY THIRD PARTY WITHOUT DELL'S EXPRESS WRITTEN CONSENT.



DELL CONFIDENTIAL/PROPRIETARY

Compal Electronics, Inc.

Title		
POWER CONTROL		
Size	Document Number	Rev
	TOBAGO-LA2151	0.6
Date:	Monday, October 13, 2004	Sheet 3/ of 51

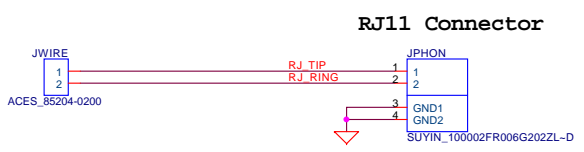
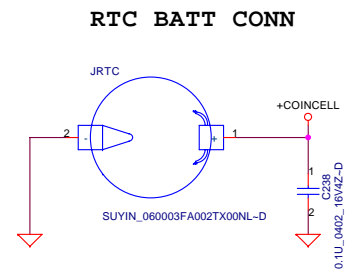
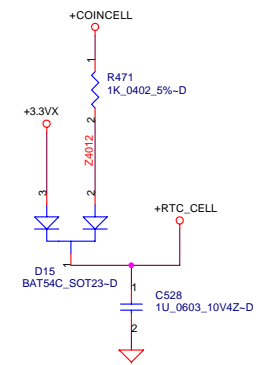
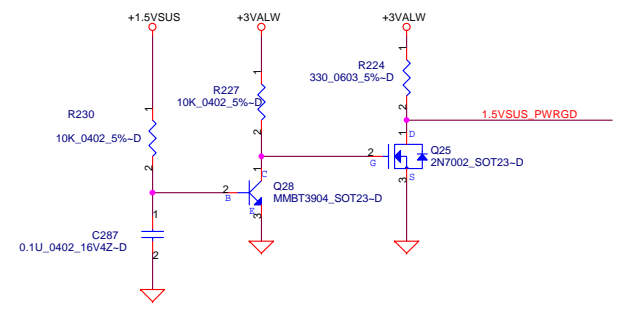
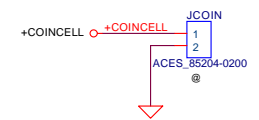
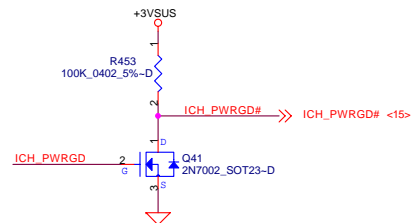
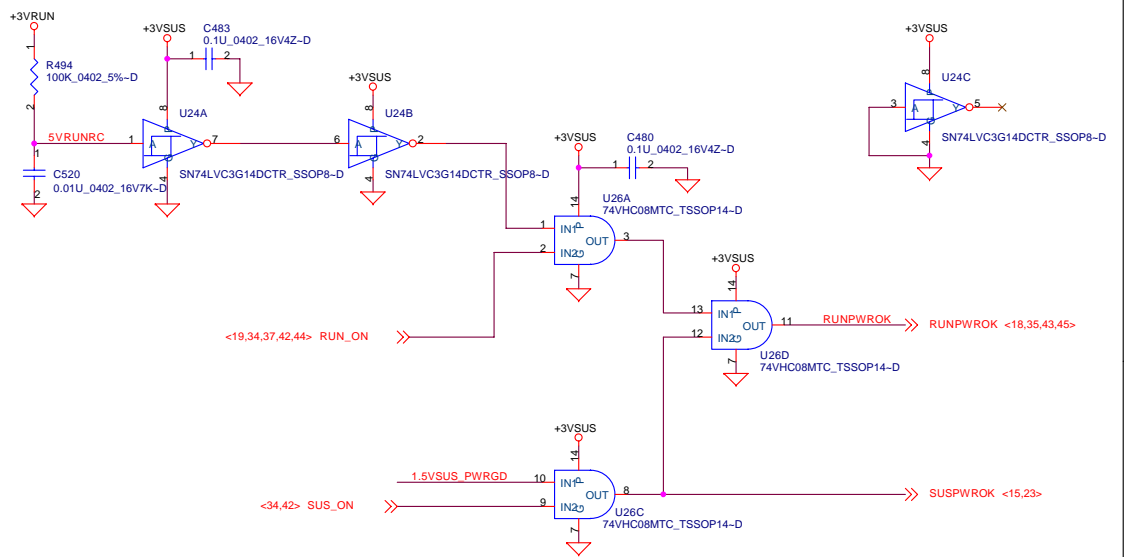
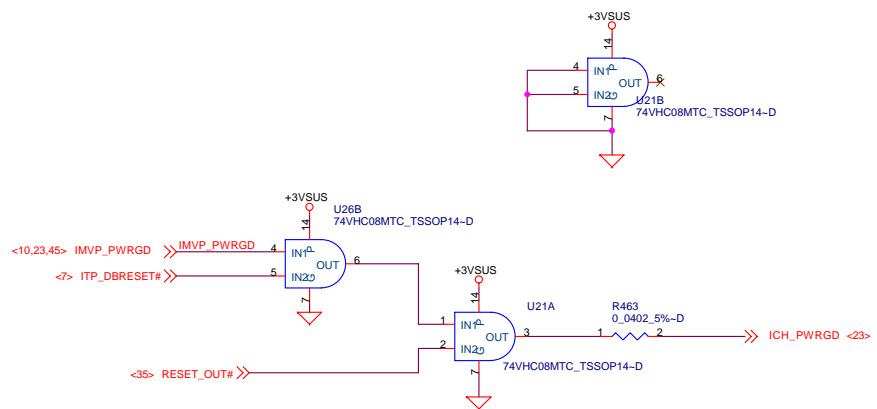

PROPRIETARY NOTE: THIS SHEET OF ENGINEERING DRAWING AND SPECIFICATIONS CONTAINS CONFIDENTIAL TRADE SECRET AND OTHER PROPRIETARY INFORMATION OF DELL INC. ("DELL"). THIS DOCUMENT MAY NOT BE TRANSFERRED OR COPIED WITHOUT THE EXPRESS WRITTEN AUTHORIZATION OF DELL. IN ADDITION, NEITHER THIS SHEET NOR THE INFORMATION IT CONTAINS MAY BE USED BY OR DISCLOSED TO ANY THIRD PARTY WITHOUT DELL'S EXPRESS WRITTEN CONSENT.

DELL CONFIDENTIAL/PROPRIETARY
Compal Electronics, Inc.

Power Good

Title: TOBAGO-LA2151
 Size: Document Number
 Date: Monday, October 13, 2008
 Sheet: 38 of 51

Rev: 0.6

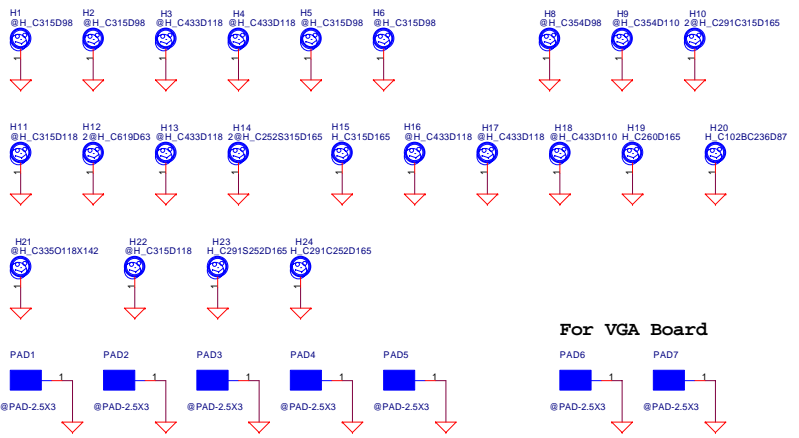

Fiducial Mark

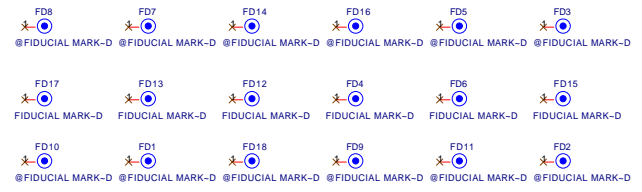

PCB
DA30
LA-2151 REV 0
MB

For VGA Board

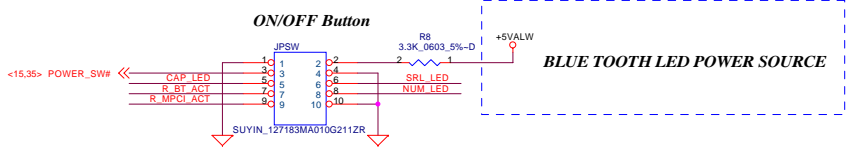
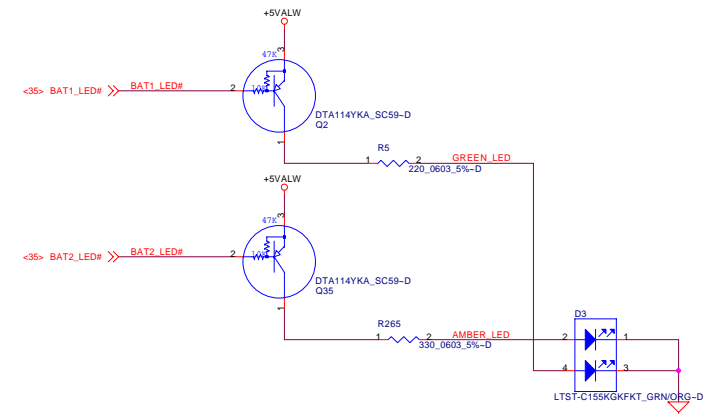
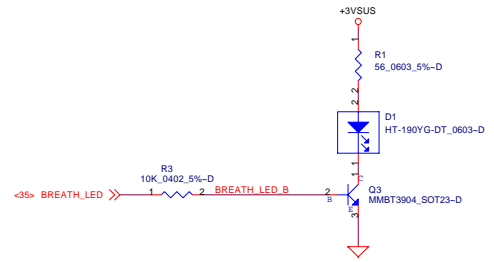
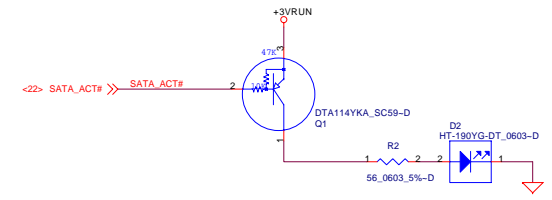
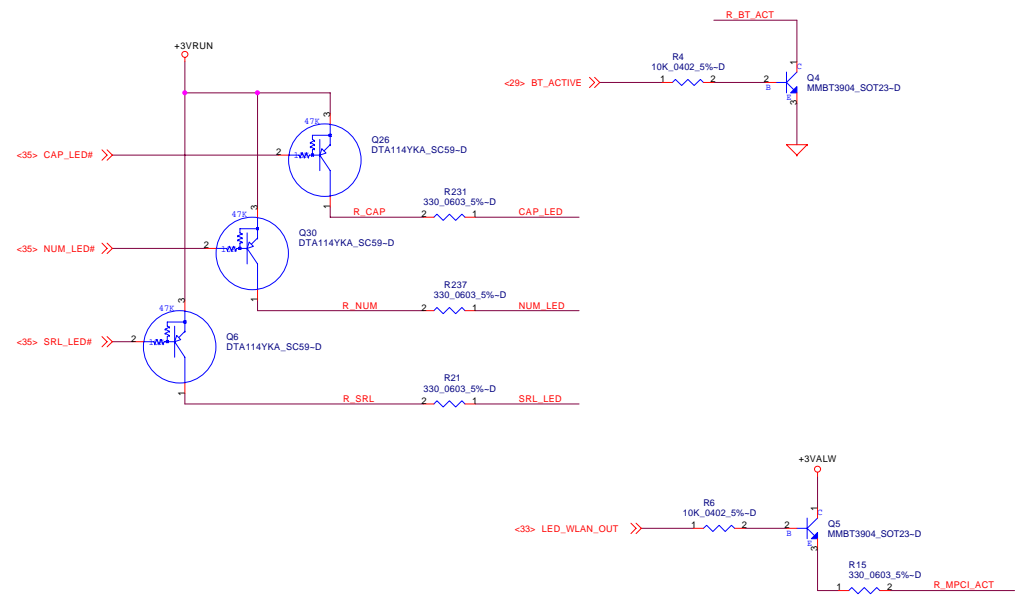
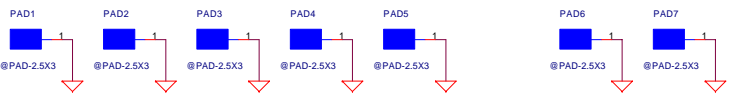

PROPRIETARY NOTE: THIS SHEET OF ENGINEERING DRAWING AND SPECIFICATIONS CONTAINS CONFIDENTIAL TRADE SECRET AND OTHER PROPRIETARY INFORMATION OF DELL INC. ("DELL"). THIS DOCUMENT MAY NOT BE TRANSFERRED OR COPIED WITHOUT THE EXPRESS WRITTEN AUTHORIZATION OF DELL. IN ADDITION, NEITHER THIS SHEET NOR THE INFORMATION IT CONTAINS MAY BE USED BY OR DISCLOSED TO ANY THIRD PARTY WITHOUT DELL'S EXPRESS WRITTEN CONSENT.

DELL CONFIDENTIAL/PROPRIETARY

Compal Electronics, Inc.

PAD and Standoff

Size	Document Number	Rev
	TOBAGO-LA2151	0.5
Date:	Wednesday, November 03, 2004	Sheet 39 of 51

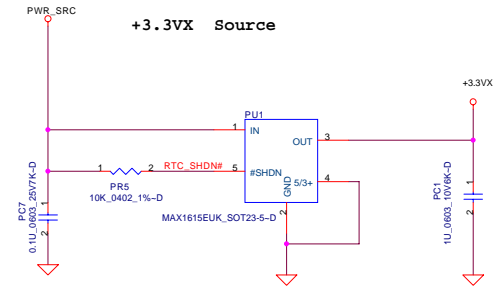
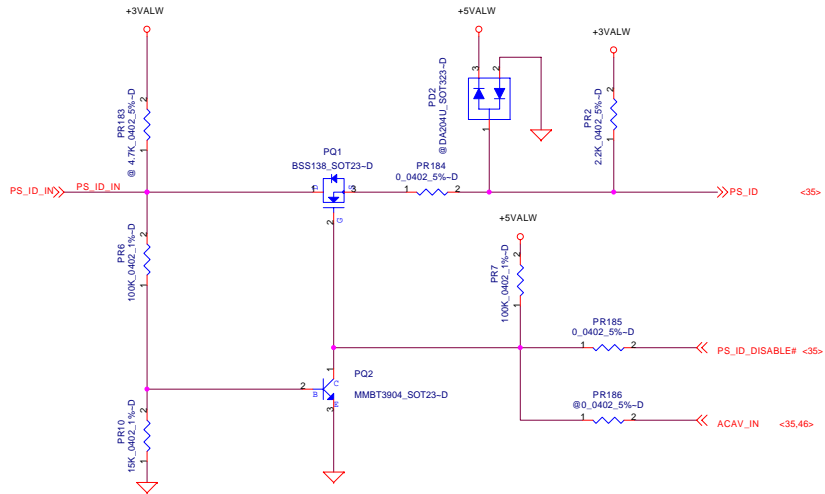

Z-series AC Adaptor Connector

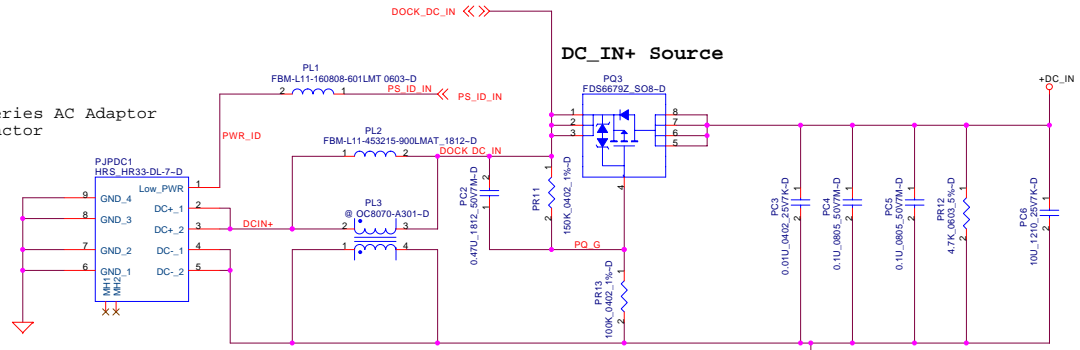

THESE CAPS MUST BE NEXT TO JCHG

DELL CONFIDENTIAL/PROPRIETARY

Compal Electronics, Inc.

+DCIN

Size	Document Number	Rev
	TOBAGO-LA2151	0.5
Date	Monday, October 18, 2004	Sheet 40 of 51

THIS SHEET OF ENGINEERING DRAWING IS THE PROPRIETARY PROPERTY OF COMPAL ELECTRONICS, INC. AND CONTAINS CONFIDENTIAL AND TRADE SECRET INFORMATION. THIS SHEET MAY NOT BE TRANSFERRED FROM THE CUSTODY OF THE COMPETENT DIVISION OF R&D DEPARTMENT EXCEPT AS AUTHORIZED BY COMPAL ELECTRONICS, INC. NEITHER THIS SHEET NOR THE INFORMATION IT CONTAINS MAY BE USED BY OR DISCLOSED TO ANY THIRD PARTY WITHOUT PRIOR WRITTEN CONSENT OF COMPAL ELECTRONICS, INC.

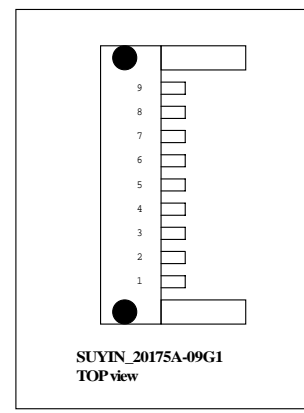
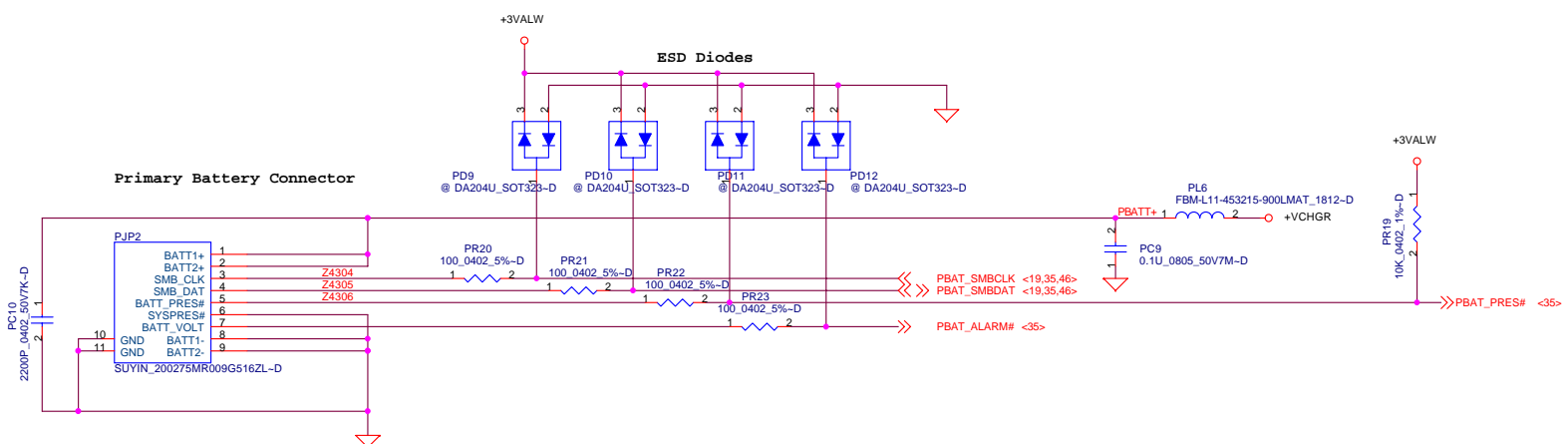

+2.5VRUN $R1=R2 * (V_o / 0.8 - 1)$, $R2: 25K \sim 100K$.

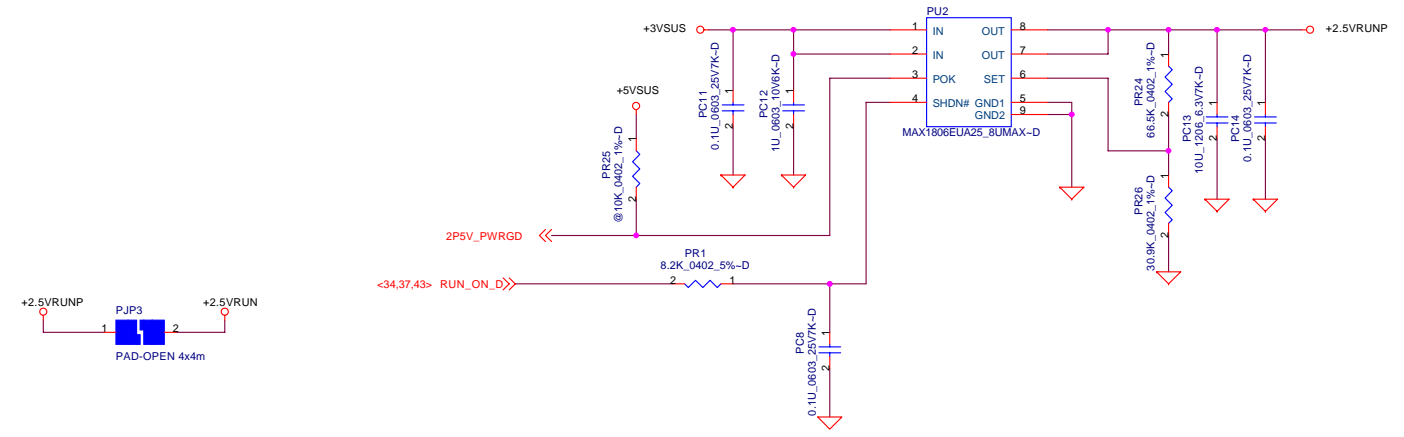

DELL CONFIDENTIAL/PROPRIETARY

Compal Electronics, Inc.

Battery ConnJ+2.5V

Title	Battery ConnJ+2.5V	
Size	Document Number	Rev
	TOBAGO-LA2151	0.6
Date:	Monday, October 18, 2004	Sheet 41 of 51

THIS SHEET OF ENGINEERING DRAWING IS THE PROPRIETARY PROPERTY OF COMPAL ELECTRONICS, INC. AND CONTAINS CONFIDENTIAL AND TRADE SECRET INFORMATION. THIS SHEET MAY NOT BE TRANSFERRED FROM THE CUSTODY OF THE COMPETENT DIVISION OF R&D DEPARTMENT EXCEPT AS AUTHORIZED BY COMPAL ELECTRONICS, INC. NEITHER THIS SHEET NOR THE INFORMATION IT CONTAINS MAY BE USED BY OR DISCLOSED TO ANY THIRD PARTY WITHOUT PRIOR WRITTEN CONSENT OF COMPAL ELECTRONICS, INC.

DC/DC +3V/ +5V/ +15V

Design current 3.4A for +3.3VSUSP
 Peak current 4.758A for +3VSUSP
 OCP point is from 5A to 8A

Place these CAPS close to FETs

Design current 4A for +5VSUSP
 Peak current 5.7A for +5VSUSP
 OCP point is from 6A to 9A

Place these CAPS close to FETs

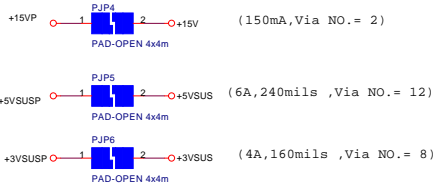
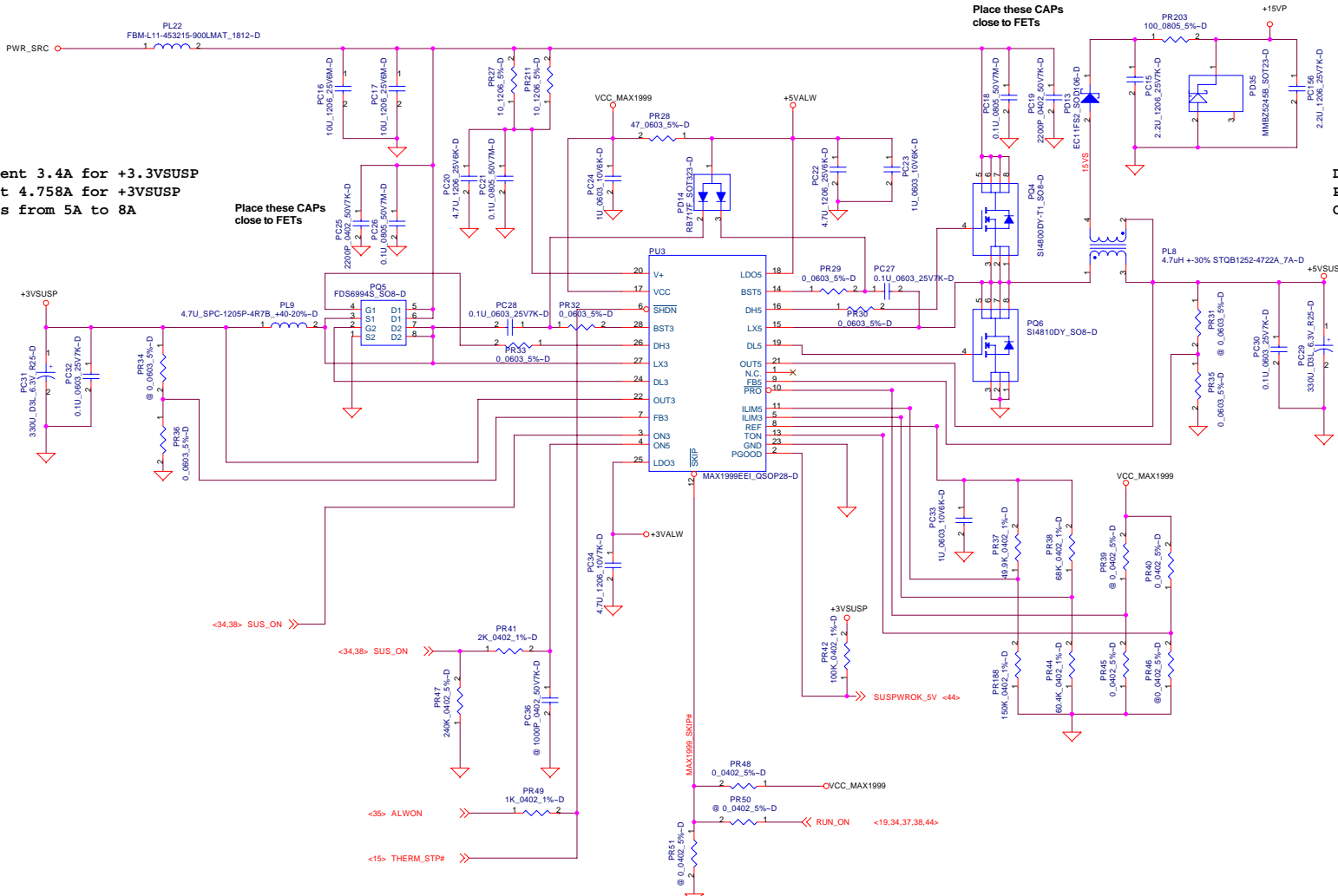

DELL CONFIDENTIAL/PROPRIETARY

Compal Electronics, Inc.

+3.3V/+5V/+15V

Title	+3.3V/+5V/+15V	
Size	Document Number	Rev
	TOBAGO-LA2151	0.5
Date	Monday, October 18, 2004	Sheet 42 of 51

THIS SHEET OF ENGINEERING DRAWING IS THE PROPRIETARY PROPERTY OF COMPAL ELECTRONICS, INC. AND CONTAINS CONFIDENTIAL AND TRADE SECRET INFORMATION. THIS SHEET MAY NOT BE TRANSFERRED FROM THE CUSTODY OF THE COMPETENT DIVISION OF R&D DEPARTMENT EXCEPT AS AUTHORIZED BY COMPAL ELECTRONICS, INC. NEITHER THIS SHEET NOR THE INFORMATION IT CONTAINS MAY BE USED BY OR DISCLOSED TO ANY THIRD PARTY WITHOUT PRIOR WRITTEN CONSENT OF COMPAL ELECTRONICS, INC.

+1.5VSUSP / +VCCP_1P05VP

Design current 3A for +1.5VSUSP
 Peak current 4.034A for +1.5VSUSP
 OCP point is from 4.5A to 7A

Design current 5A for +VCCP_1P05VP
 Peak current 7.124A for +VCCP_1P05VP
 OCP point is from 7.5A to 11A

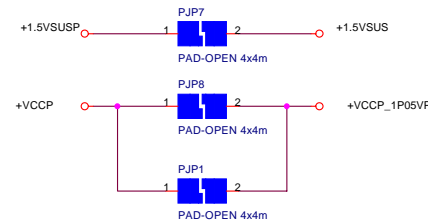
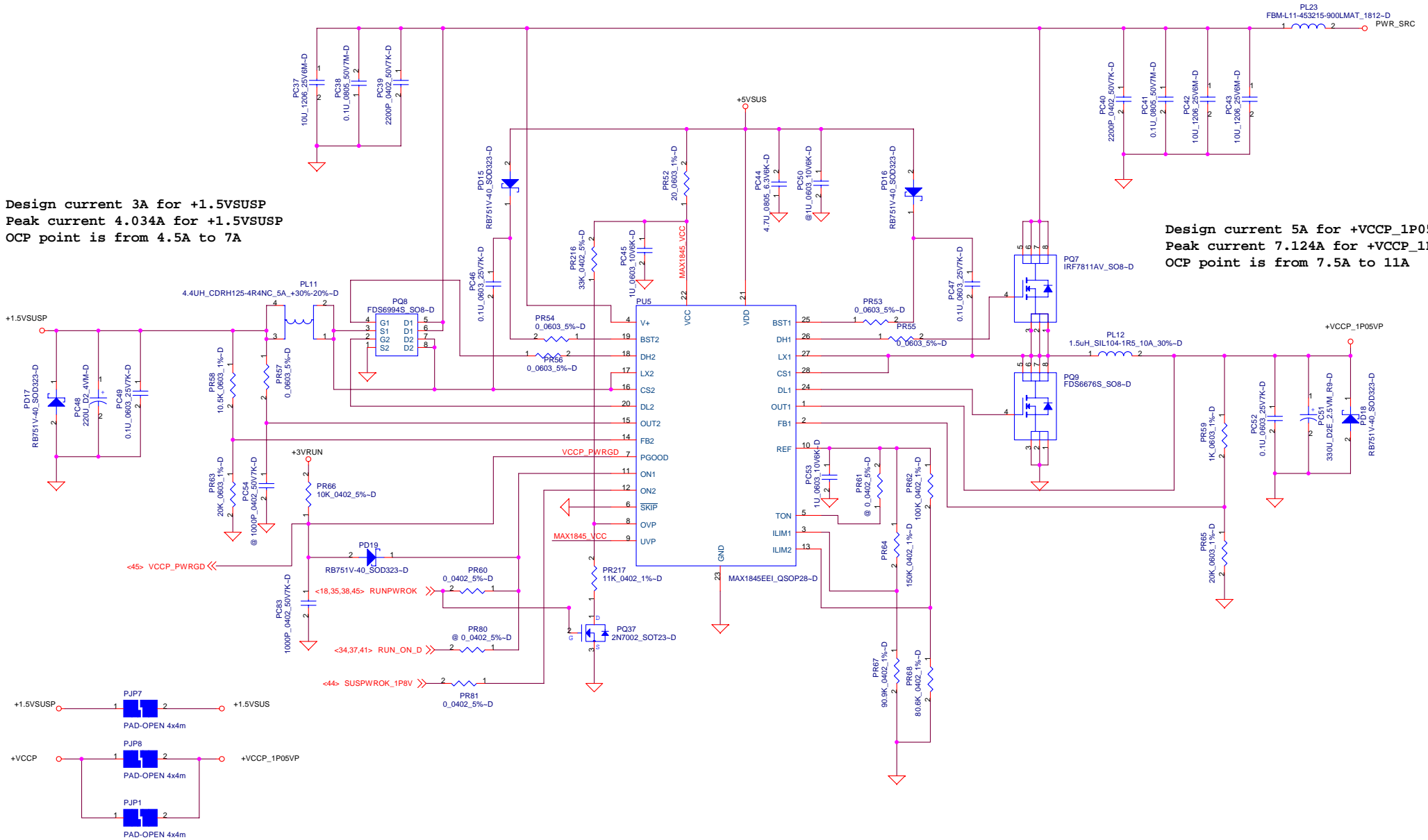

DELL CONFIDENTIAL/PROPRIETARY

THIS SHEET OF ENGINEERING DRAWING IS THE PROPRIETARY PROPERTY OF COMPAL ELECTRONICS, INC. AND CONTAINS CONFIDENTIAL AND TRADE SECRET INFORMATION. THIS SHEET MAY NOT BE TRANSFERRED FROM THE CUSTODY OF THE COMPETENT DIVISION OF R&D DEPARTMENT EXCEPT AS AUTHORIZED BY COMPAL ELECTRONICS, INC. NEITHER THIS SHEET NOR THE INFORMATION IT CONTAINS MAY BE USED BY OR DISCLOSED TO ANY THIRD PARTY WITHOUT PRIOR WRITTEN CONSENT OF COMPAL ELECTRONICS, INC.

Compal Electronics, Inc.			
+1.5VSUSP /+VCCP_1P05VP			
File	Document Number	Rev	
	TOBAGO-LA2151	0.6	
Date:	Monday, October 18, 2004	Sheet	43 of 51

+1.8VSUSP/ +0.9V_DDR_VTT DDR2 Termination

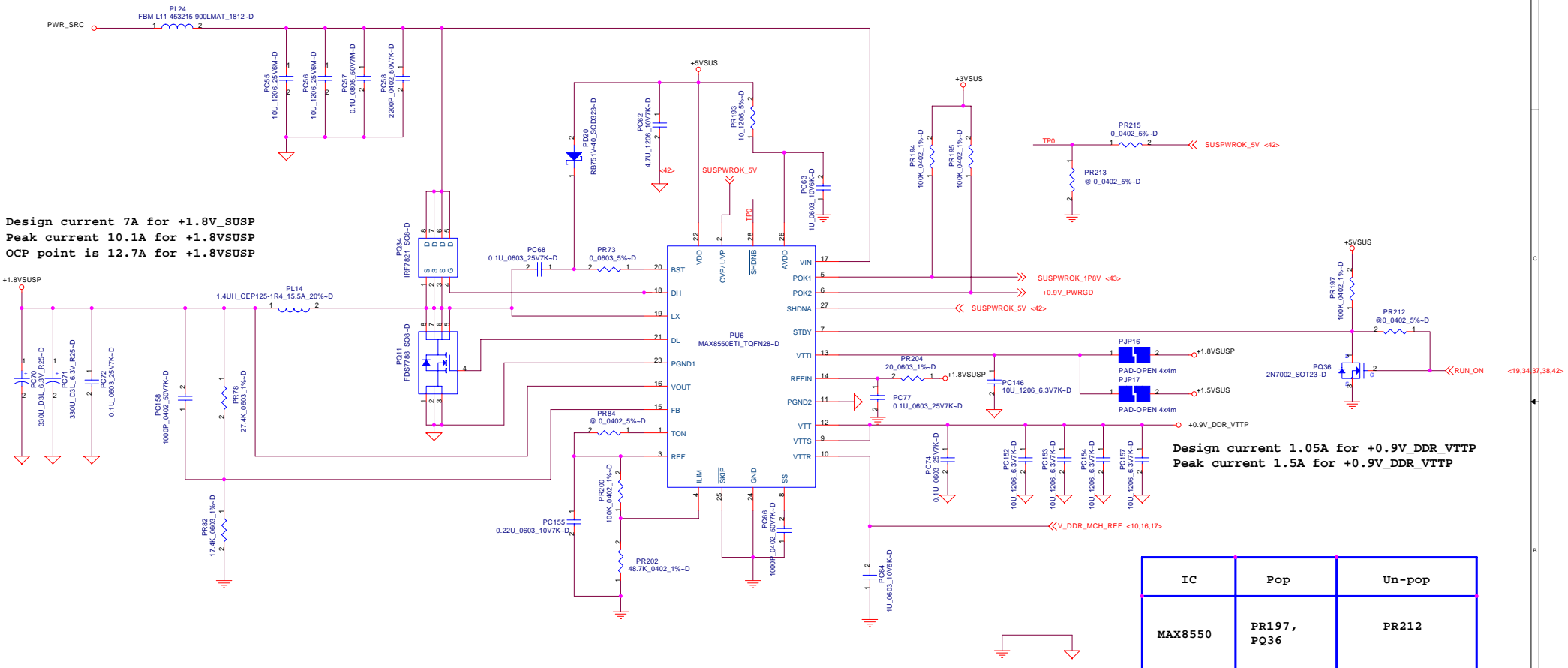

Design current 7A for +1.8V_SUSP
Peak current 10.1A for +1.8VSUSP
OCP point is 12.7A for +1.8VSUSP

Design current 1.05A for +0.9V_DDR_VTTP
Peak current 1.5A for +0.9V_DDR_VTTP

IC	Pop	Un-pop
MAX8550	PR197, PQ36	PR212
MAX8550A	PR212	PR197, PQ36

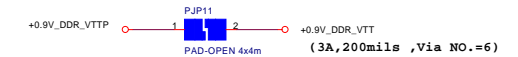
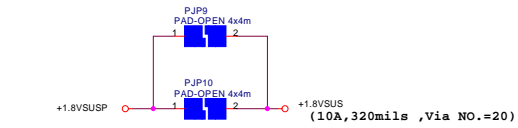

DELL CONFIDENTIAL/PROPRIETARY

Compal Electronics, Inc.	
+1.8VSUSP/ +0.9V_DDR_VT	
Size	Document Number
TOBAGO-LA2151	
Date: Monday, October 18, 2004	Sheet 44 of 51

PROPRIETARY NOTE: THIS SHEET OF ENGINEERING DRAWING AND SPECIFICATIONS CONTAINS CONFIDENTIAL TRADE SECRET AND OTHER PROPRIETARY INFORMATION OF DELL INC. ("DELL") THIS DOCUMENT MAY NOT BE TRANSFERRED OR COPIED WITHOUT THE EXPRESS WRITTEN AUTHORIZATION OF DELL. IN ADDITION, NEITHER THIS SHEET NOR THE INFORMATION IT CONTAINS MAY BE USED BY OR DISCLOSED TO ANY THIRD PARTY WITHOUT DELL'S EXPRESS WRITTEN CONSENT.

V I D							Vcore
VID 5	VID 4	VID 3	VID 2	VID 1	VID 0	V	
0	1	1	1	1	0	1.484	
0	1	1	0	0	1	1.308	
1	0	1	1	1	1	0.956	
1	1	1	1	0	0	0.748	

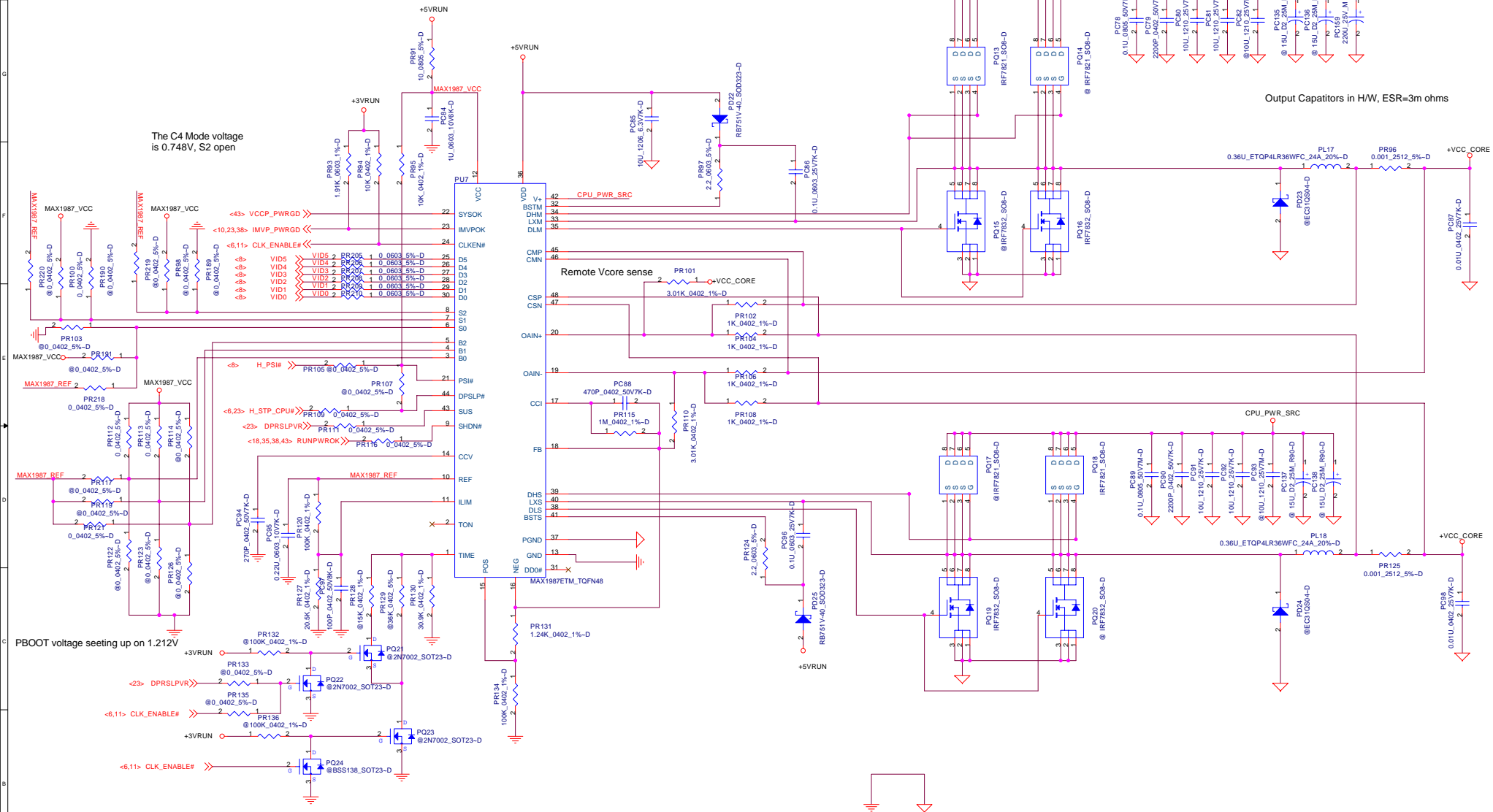

Change PR130:30.9k. Delete PR128/PR129/PR132/PR133/PR136/PQ21/PQ22/PQ23/PQ24 for BANIAS and DOTHAN
 PR128/PR129/PR132/PR133/PR136/PQ21/PQ22/PQ23/PQ24 are only for YONAH CPU.

- TRANSITION TIMING:**
- (a): START-UP and SHUTDOWN(SUS=LOW,RUNPWROK=LOW): 2mV/us
 - (b): ENTER SUSPEND (SUS=HIGH,RUNPWROK=HIGH): 8.6mV/us
 - (c): EXIT SUSPEND (SUS=LOW, RUNPWROK=HIGH): 24.7mV/us

THIS SHEET OF ENGINEERING DRAWING IS THE PROPRIETARY PROPERTY OF COMPAL ELECTRONICS, INC. AND CONTAINS CONFIDENTIAL AND TRADE SECRET INFORMATION. THIS SHEET MAY NOT BE TRANSFERRED FROM THE CUSTODY OF THE COMPETENT DIVISION OF R&D DEPARTMENT EXCEPT AS AUTHORIZED BY COMPAL ELECTRONICS, INC. NEITHER THIS SHEET NOR THE INFORMATION IT CONTAINS MAY BE USED BY OR DISCLOSED TO ANY THIRD PARTY WITHOUT PRIOR WRITTEN CONSENT OF COMPAL ELECTRONICS, INC.

DELL CONFIDENTIAL/PROPRIETARY

Compal Electronics, Inc.

+VCCORE

Size	Document Number	Rev
	TOBAGO-LA2151	0.5
Date:	Monday, October 18, 2004	Sheet 45 of 51

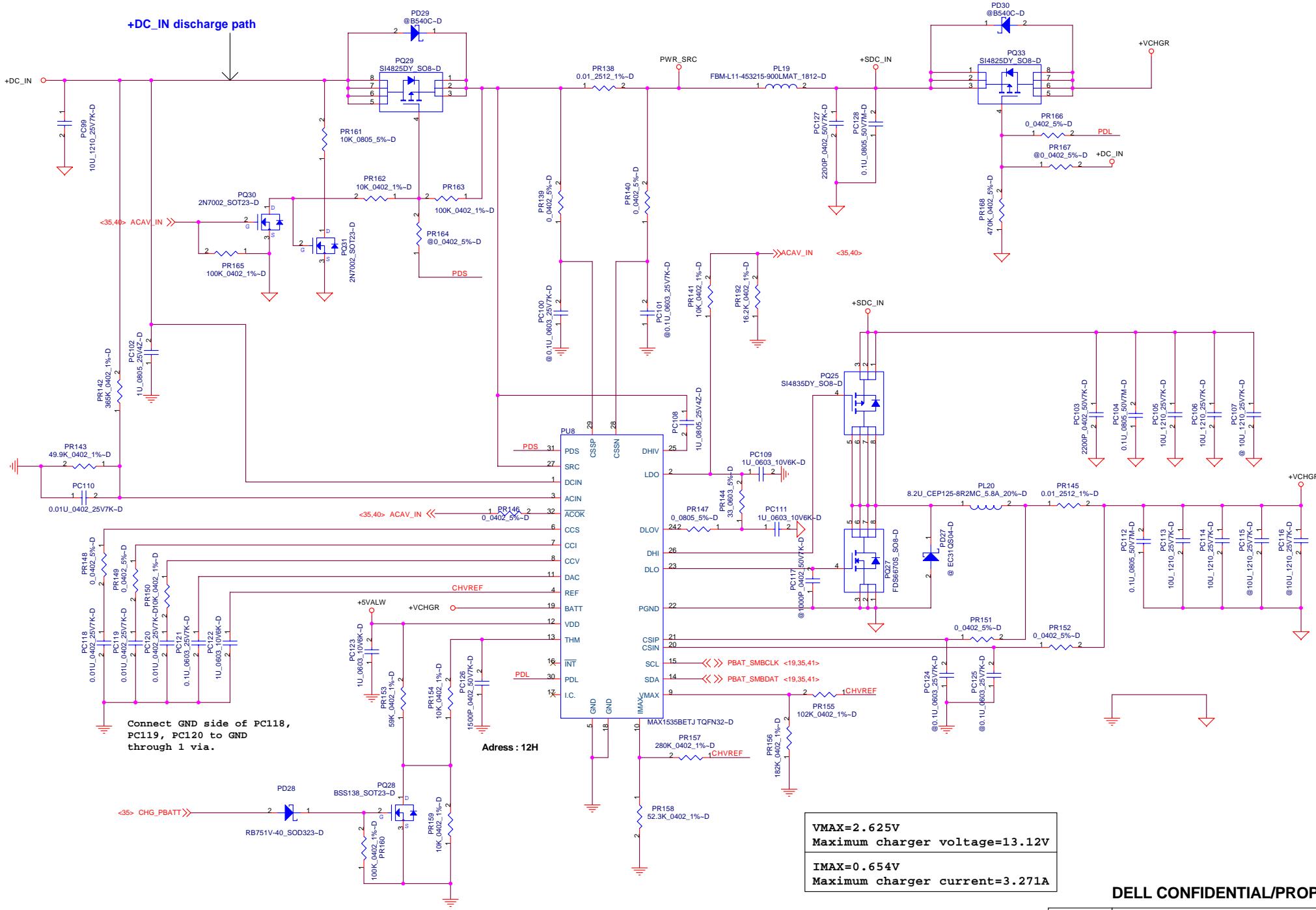

+DC_IN discharge path

Connect GND side of PC118, PC119, PC120 to GND through 1 via.

Address : 12H

VMAX=2.625V
 Maximum charger voltage=13.12V
 IMAX=0.654V
 Maximum charger current=3.271A

THIS SHEET OF ENGINEERING DRAWING IS THE PROPRIETARY PROPERTY OF COMPAL ELECTRONICS, INC. AND CONTAINS CONFIDENTIAL AND TRADE SECRET INFORMATION. THIS SHEET MAY NOT BE TRANSFERRED FROM THE CUSTODY OF THE COMPETENT DIVISION OF R&D DEPARTMENT EXCEPT AS AUTHORIZED BY COMPAL ELECTRONICS, INC. NEITHER THIS SHEET NOR THE INFORMATION IT CONTAINS MAY BE USED BY OR DISCLOSED TO ANY THIRD PARTY WITHOUT PRIOR WRITTEN CONSENT OF COMPAL ELECTRONICS, INC.

DELL CONFIDENTIAL/PROPRIETARY



Compal Electronics, Inc.		
Charger		
Title	Document Number	Rev
	TOBAGO-LA2151	0.6
Date: Monday, October 13, 2004	Sheet 46	of 51

Version Change List (P. I. R. List)

Item	Page#	Title	Date	Request Owner	Issue Description	Solution Description	Rev.
1	ALL	H/W	01/19	Roger	Rename component location for manufacture	Update schematic and board file component reference	0.1
2	30	H/W	01/19	Roger	R2151 tie +3VLAN to GND via LAN transformer	Change R1251 (0_0402_5%-D) to C34(1000P_0402_50V7K~D)	0.1
3	39	H/W	01/19	Roger	The light of WLAN and Blue tooth LED too dim	Change R8, R15 from 330 ohm to 56 ohm	0.1
4	34	H/W	01/19	Roger	Add the COM port debug circuit	Add U184 for COM port debug	0.1
5	36	H/W	01/28	Roger	Rotate the Keyboard connector 180 degree	Reconnect keyboard signals to CN1,CN2,CN3,CN4,CN5,C207 for layout smoothly	0.1
6	36	H/W	01/30	Roger	Keep more spacing for VGA thermal solution	Delete JP3 debug port to save spacing for ROM part placement	0.1
7	12	H/W	02/03	Roger	+2.5VRUN is margin for 2N7002	Change Q7,Q27,Q31,Q33 gate voltage from +2.5VRUN to +3VRUN	0.1
8	06	H/W	02/04	Roger	Change R330 and R354 to 0 ohms per Intel review.	Change R330 and R354 from 1K to 0 ohms	0.1
9	38	H/W	02/04	Roger	Resolves the issue where 1.5VSUS_PWRGD goes high before +1.5VSUS	Change R230 from 330 to 10K ohm and R227 from 1K to 10K ohms	0.1
10	37	H/W	02/09	Roger	Resolves the issue where +1.5VRUN drop 100 mV from +1.5VSUS to +1.5VRUN.	Change Q44 from SI3456 to SI4810 that have lower Rds on.	0.1
11	18	H/W	02/09	Roger	Add a bulk cap for G_PWR_SRC	Add C569 for G_PWR_SRC placement near JVID	0.1
12	39	H/W	02/09	Roger	BAT1_LED# should drive the GREEN LED, BAT2_LED# should drive the ORANGE LED	Change R5 pin 2 connect to D3 pin4, R265 pin2 connect to D3 pin2	0.1
13	21	H/W	02/09	Roger	Follow X01 Gerber Gate Checklist item 11	Change R328 from 0 ohm to 1K ohm and add note "Pop resistor to boot from PCI".	0.1
14	38	H/W	02/09	Roger	Follow X01 Gerber Gate Checklist item 12, ICH_PWRGD circuit match Laguna	Remove R470 and no connect U21B, RESET_OUT# connector to U21A pin 2.	0.1
15	35	H/W	02/09	Roger	Change Board ID to X01	Depop R419 and populate R405	0.1
16	35	H/W	02/09	Roger	System will auto power on when AC plug in if RTC coin battery not implement	Change C130 from 1U to 100P to reduce POWER_SW_IN# rising time.	0.1
17	06	H/W	02/10	Roger	Reserve SSC clock for internal graphic for clock generator ICS954206	96MHz SSC clock connect to U16 pin 17,18. Add the serie damping R524, R525, pull down resistor R522, R523.	0.1
18	ALL	H/W	02/11	Roger	Change connector name to match the naming rule	Change JP5 to JMOD, JP6 to JWIRE, JP2 to JPSW, JP1 to JLVDS, JP4 to JCRT	0.1
19	23	H/W	02/16	Roger	+1.5VRUN leakage issue at system into S3 status	ICH6M GPIO24 connect to SIO_EXT_WAK# for option the GPIO power plane	0.1
20	39	ME	02/17	Roger	Change screw hole size for system assembly	H15 change diameter form 3 mm to 4.2 mm, H18 change diameter from 3 mm to 2.8 mm	0.1
21	34	H/W	02/22	Roger	Change the power source from +RTC_CELL to +3.3VX	Depop R116 and pop R114, Depop R119 and pop R128	0.1
22	35	H/W	02/22	Roger	Auto power on when AC plug in issue will be using the BIOS fix	C130 change from 100P 0603 to 1U 0603	0.1
23	39	H/W	03/12	Roger	LED_WLAN_OUT should drive green LED	Change R15 from 56 ohms to 330 ohms	0.1
24	29,39	H/W	03/12	Roger	Blue tooth and meida Blue LED trun on voltage Vf is 2.7 to 3.9V. +3.3V have risk don't trun on LED.	Change Q4 pin 1 and JLCM pin19 power source from +3VALW to +5VALW	0.1

PROPRIETARY NOTE: THIS SHEET OF ENGINEERING DRAWING AND SPECIFICATIONS CONTAINS CONFIDENTIAL TRADE SECRET AND OTHER PROPRIETARY INFORMATION OF DELL INC. ("DELL") THIS DOCUMENT MAY NOT BE TRANSFERRED OR COPIED WITHOUT THE EXPRESS WRITTEN AUTHORIZATION OF DELL. IN ADDITION, NEITHER THIS SHEET NOR THE INFORMATION IT CONTAINS MAY BE USED BY OR DISCLOSED TO ANY THIRD PARTY WITHOUT DELL'S EXPRESS WRITTEN CONSENT.

DELL CONFIDENTIAL/PROPRIETARY			
Changed-List History 1/2			
Size	Document Number		Rev
	TOBAGO-LA2151		0.6
Date:	Monday, October 18, 2004		Sheet 47 of 51

Version Change List (P. I. R. List)

Item	Page#	Title	Date	Request Owner	Issue Description	Solution Description	Rev.
25	35	H/W	03/17	Roger	SIO SM Bus EA measure issue for rising and falling time	R131, R444, R447, R449 change from 22K ohms to 8.2K ohms	0.3
26	6	H/W	03/17	Roger	ICH SM Bus EA measure issue for rising and falling time	R270, R275 change from 100K ohms to 2.2K ohms	0.3
27	19	H/W	03/17	Roger	LCDVDD component unnecessary for external board	Depop Q8, Q9, Q10, Q37, R35, R54, R263, R272, C29, C315 on external board and pop on internal board	0.3
28	13	H/W	03/18	Roger	Remove CRT, LVDS, TV DAC power beads and caps	Depop L9, L10, L11, L25, L26, L24, C24, C291, C293, C22, C298, C299, C23, C323, C310, C297, C314, C331, C322, C37, C35, C305, C306, C36, C304 on external board and pop on internal board	0.3
29	31	H/W	03/19	Roger	Card bus EA measure CBS_CCLK rising and falling failure issue	R495 change from 47 ohms to 22 ohms	0.3
30	27	H/W	03/23	Roger	ME change audio jacks to combined jack	Change JAUDIO symbol to combined two jacks, delete JHP	0.3
31	15	H/W	03/25	Roger	PT layout issue list item 6, consistent with other platforms	Change U15 pin 10 power source from +3.3VX to +RTC_CELL	0.3
32	26	H/W	03/25	Roger	Layout issue list item 16, pop issue and the static noise during post and idle in Windows	Add a non-popped inverter U30 add a 0 ohm R528 around the inverter	0.3
33	25	H/W	03/25	Roger	Issue list item 8, connect UART interface to ICH GPIO for debug	Connect U11 pin 45 (UAO) to ICH6 pin AC18 (GPIO34). Connect U11 pin 43 (UAI) to ICH6 pin AF20 (GPIO33)	0.3
34	26	H/W	03/25	Roger	Issue list item 11, allow the capability to disable the line in option	Connect a no popped 0 ohm R529 from LINE_IN_L to 9750_PHONE. Connect a no popped 0 ohm R530 from LINE_IN_R to 9750_PHONE	0.3
35	39	H/W	03/25	Roger	Issue list item 12, blue LED to dim	LED & R58 move to collection side of BJT. Q4 pin 3 connect to GND, JPSW pin 2 change to connect +5VALW.	0.3
36	18	H/W	03/25	Roger	Issue list item 9, C569 not require fo now	Add non-popped symbol for C569	0.3
37	29	H/W	03/26	Roger	EMI request add a cap place near R518 for blue tooth	Add C570 (33P_0402_50V8J~D)	0.3
38	34	H/W	03/28	Roger	Issue list item 7, swap SIO_PWRBTN# and ICH_PCIE_WAKE# to fix WOL issue on Laguna	Swap SIO_PWRBTN# (U20 pin A15) and ICH_PCIE_WAKE# (U20 pin A13)	0.3
39	35	H/W	03/28	Roger	Change board ID to (0010) for X02 board	Pop R94, R419 and non-popped R107, R405	0.3
40	6	H/W	03/28	Roger	Reserved clock gernerator pin53 for 14.318 MHz for ICS 954206	Add a 12.1 ohms series resistor R531 to U16 pin 53 and connect to CLK_CODEC_14M. Isolation resistor R531 connect to CLKSEL0	0.3
41	6	H/W	04/01	Roger	TV out B/W issue on UMA configuration	Pop C329 and C333 with 27P to fine tune the crystal frequency and clock sequence	0.3
42	15	H/W	04/02	Roger	FAN RPM detect issue	Change C209 to 1000P and de-popped	0.3
43	26	H/W	04/04	Roger	Solve the pop issue and the static noise during post and idle in Windows	Pop U30 inverter and depop R528 (0_0402_5%)	0.3
44	27	H/W	04/04	Roger	Tune audio amplifier gain to 21.6dB	Pop R164 (10K_0402_5%) and depop R107 (10K_0402_5%)	0.3
45	37	H/W	04/04	Roger	For the +5VHDD power source, use +5VRUN	Depop Q51, Q50, R507, C547 and pop R506 (0_0805_5%)	0.3
46	27	H/W	04/04	Roger	Dell Audio team request	C535, C536 change from 0.47UF to 0.1UF and C199, C206 change from 2.2UF to 0.1F	0.3
47	38	H/W	04/07	Roger	PCI clocks to ICH_PWRGD timing too late issue. SPEC is at least 99 ms	Change C520 form 0.1UF to 0.01UF	0.3
48	13	H/W	04/07	Roger	Intel Design Guide recommend populate TV DAC & CRT DAC power inputs filtering	Change back population L9, L10, L11, L25, L26, L24, C24, C291, C293, C22, C298, C299, C23, C323, C310, C297, C314, C331, C322, C37, C35, C305, C306, C36, C304 on external board	0.3

PROPRIETARY NOTE: THIS SHEET OF ENGINEERING DRAWING AND SPECIFICATIONS CONTAINS CONFIDENTIAL TRADE SECRET AND OTHER PROPRIETARY INFORMATION OF DELL INC. ("DELL") THIS DOCUMENT MAY NOT BE TRANSFERRED OR COPIED WITHOUT THE EXPRESS WRITTEN AUTHORIZATION OF DELL. IN ADDITION, NEITHER THIS SHEET NOR THE INFORMATION IT CONTAINS MAY BE USED BY OR DISCLOSED TO ANY THIRD PARTY WITHOUT DELL'S EXPRESS WRITTEN CONSENT.



DELL CONFIDENTIAL/PROPRIETARY

Title **Changed-List History 1/2**

Size Document Number **TOBAGO-LA2151** Rev 0.6

Date: Monday, October 18, 2004 Sheet 48 of 51

Version Change List (P. I. R. List)

Item	Page#	Title	Date	Request Owner	Issue Description	Solution Description	Rev.
49	6,10,22	H/W	04/28	Roger	Modify pop option for B1 stepping Dothan CPU for ST build	Depop R305, R364, R438. Pop R329, R343, R88 for both UMA and discrete mother board	0.4
50	18,35	H/W	05/06	Roger	Add smart dimmer function for VGA board	U20 pin E3 (BIA_PWM) connect to JVID pin4 isolate by R534 and U4 pin E25 isolate by R533	0.4
51	24	H/W	05/06	Roger	ICH_V5REF_RUN leakage issue	Reserve R535 for +5VRUN power source	0.4
52	6	H/W	05/17	Roger	R274 burn out issue	Change R274 (1 ohm) from 0402 to 0603 size, R273,R401(2.2 ohms) from 0402 to 0603 size.	0.4
53	39	H/W	05/19	Roger	Increase breath and HDD active LED light	Breath LED circuit change to like the Bluetooth LED circuit, R1 & R2 change from 330 ohms to 56 ohms	0.4
54	25	H/W	05/19	Roger	X03 issue list item7, modify the SATA crystal circuit	Connect R190 pin1 to U11 pin23, connect pin2 to Y1 pin 2	0.4
55	25	H/W	05/19	Roger	X03 issue list item8, reserve oscillator for instead of crystal for marvell 8040	Add a non-pop oscillator Y3 (25MHz) connect to U11 pin22, Pin23	0.4
55	24	H/W	05/19	Roger	X03 issue list item8, ICH leakage issue	Reserve R537 connect +5VSUS for ICH_5VREF_SUS power source	0.4
56	15	H/W	06/01	Roger	OTP shutdown temperature varies. Offset 6 degree C to 79 degree C	Change R249 from 13.1K ohms to 147K ohms to set VSET to 0.25V	0.4
57	27	H/W	06/01	Roger	When audio recorded, CPU fan noise will be covered from +5VRUN	R143 change from +5VRUN to +5VSUS	0.4
58	25	H/W	06/07	Roger	HDD can't detect issue	C279, C280 change to 12 PF, Add a 25M oscillator reserve for Marvel 8040	0.4
59	36	H/W	06/07	Roger	EMC request pop keyboard matrix signal bypass caps.	Change CN1-CN6 to single 100pF cap for cost saving	0.4
60	35	H/W	06/07	Roger	Change board ID for X03 (R04)	Pop R405 and de-pop R419 (BID : 0011)	0.4
61	6	H/W	06/07	Roger	X03 issue list item 19, add pull down resistor for SRC/CLKREQ select	Add R538 (0 ohm) for pull down U16 pin 56	0.4
62	39	H/W	06/07	Roger	X03 issue list item 20, Bluetooth LED is too bright	Change R8 from 56 ohms to 1K ohms	0.4
63	27	H/W	06/08	Roger	Audio codec and U5 (MAX4411) were unified into the same power	U5 pin10, 19 and R132 pin1 change connect from +3VRUN to +VDDA	0.4
64	27	H/W	06/08	Roger	Audio amplifier power and gain setting pull up power were unified into the same power	R164 pin1 and R165 change connect from +5VRUN to +5VAMPVCC	0.4
65	13	H/W	06/09	Roger	UMA platform TV out water wave issue	Add C598 (4.7U_0805_10V4Z) for +3VRUN_ATVBG bulk	0.4
66	29	H/W	06/09	Roger	Media board signal EMI resistors no necessary now	Remove R188,R189,R193,R194,R195,R196,R197,R208,R209,R220,R221	0.4
67	25	H/W	06/11	Roger	X03 issue list item 28	Connect R204 pin1 to U11 (Marvel 8040) pin22	0.4
68	28	H/W	06/11	Roger	X03 issue list item 29,30	Add PJP21 between USBP4_PWR and USBP5_PWR, PJP22 between USBP7_PWR and USBP8_PWR	0.4
69	34,35	H/W	06/11	Roger	X03 issue list item 31,32	Pop R116 and no-pop R114, pop R119 and no-pop R128 to change power source from +3.3VX to +RTC_CELL	0.4
70	37	H/W	06/11	Roger	Supply +1.8VRUN for Graphic board from Mother board	Change Q14 from SI2456 to SI4810 for larger power margin.	0.4
71	38	H/W	06/11	Roger	Reserved option to use the Sullivan/Laguna rbatt	Add JCOIN connect to +COINCELL	0.4
72	30	H/W	06/11	Roger	According to the crystal vendor measure report	Change R264 from 200 to 820 ohms to reduce the drive level	0.4

PROPRIETARY NOTE: THIS SHEET OF ENGINEERING DRAWING AND SPECIFICATIONS CONTAINS CONFIDENTIAL TRADE SECRET AND OTHER PROPRIETARY INFORMATION OF DELL INC. ("DELL") THIS DOCUMENT MAY NOT BE TRANSFERRED OR COPIED WITHOUT THE EXPRESS WRITTEN AUTHORIZATION OF DELL. IN ADDITION, NEITHER THIS SHEET NOR THE INFORMATION IT CONTAINS MAY BE USED BY OR DISCLOSED TO ANY THIRD PARTY WITHOUT DELL'S EXPRESS WRITTEN CONSENT.

DELL CONFIDENTIAL/PROPRIETARY			
Changed-List History 1/2			
Size	Document Number		Rev
	TOBAGO-LA2151		0.6
Date:	Monday, October 18, 2004		Sheet 49 of 51

Version Change List (P. I. R. List)

Item	Page#	Title	Date	Request Owner	Issue Description	Solution Description	Rev.
73	37	H/W	06/11	Roger	+5VRUN glitch when HDD shut down	Populate Q50, Q51,R507,C547 and de-pop R506	0.4
74	26	H/W	06/14	Roger	Disable the Line In MIC function for	No Pop C510 and C512 & Pop R529 and R530	0.4
75	27	H/W	06/14	Roger	X03 issue list item 21	Change C147 and C148 from 1uF (0603) to 3.3uF (0603)	0.4
76	12	H/W	06/15	Roger	X03 issue list item 41	Change Q33, Q7, Q31, and Q27 to BSS138 and use +2.5VRUN for gate voltage	0.4
77	24	H/W	06/15	Roger	X03 issue list item 40	Change R535 to 100 ohm per Intel spec	0.4
78	22	H/W	06/17	Roger	Pop resistor for support deeper sleep	Pop R121 (0_0402_5%) and R127 (56_0402_5%)	0.4
79	25	H/W	06/17	Roger	Implement oscillator for Marvel 8040	De-pop Y1, R204, R190, C279, C280	0.4
80	28	H/W	07/21	Roger	Move USB power jump to close bulk cap	PJP21 connect R14 pin2 and R22 pin2. PJP22 connect R96 pin2 and R109 pin2	0.6
81	35	H/W	07/21	Roger	Change board ID for V0.6	Depop R94, R405, R108 and pop R107, R419, R95	0.6
82	23,34	H/W	07/27	Roger	LCD_TST for panel control by ICH6-M and SIO	LCD_TST connect to ICH6-M pin AD20(GPO21) and Macallan pin B12 (LGPIO70) isolate by R539,R540	0.6
83	9	H/W	08/01	Roger	Reduce CUP core caps for cost saving	Depop C428, C446, CC448, C431, C119, C118	0.6
84	13	H/W	08/29	Roger	Change +1.5VRUN_DPLLA, +1.5VRUN_DPLLB, +1.5VRUN_HPLL, +1.5VRUN_MPLL inductance	Change L28, L33, L38, L39 to TDK 10U_MLZ2012E100PTAIN 10 UH inductance	0.6
85	39	H/W	08/11	Roger	Balance LED brightness	Change R5 value from 330 ohms to 220 ohms	0.6
86	6	H/W	09/03	Roger	Dell other project have issue at CLKSEL0 signal	Depop R532 and pop R259	0.6
87	36	H/W	09/23	Roger	SST flash ROM part have crash issue, need to further clarify	Change SST 39VF080 to MXIC MX29LV008BTC-70R	0.6
88	39	H/W	09/23	Roger	Change the LED from non clear lens to clear lens	Change D1, D2, D3 from HARVATEK to Lite-on	0.6
89	15	H/W	11/03	Roger	Forcecon CPU fan acoustic issue	Pop C538 (2200P_0402_25V7K)	1.0
90	23	H/W	11/03	Roger	Intel sighting report #67725 workaround	Pop R433 (100K_0402)	1.0
91	10	H/W	11/03	Roger	Intel sighting report #68363 workaround	De-pop R435, R437	1.0
92	39	H/W	11/03	Roger	Blue tooth LED is too bright	Change R8 from (1K_0603) to (3.3K_0603)	1.0
92	19	H/W	11/03	Roger	fine tune G_PWR_SRC lag +3VRUN sequence issue	Change C290 form 0.1UF to 1000PF	

PROPRIETARY NOTE: THIS SHEET OF ENGINEERING DRAWING AND SPECIFICATIONS CONTAINS CONFIDENTIAL TRADE SECRET AND OTHER PROPRIETARY INFORMATION OF DELL INC. ("DELL") THIS DOCUMENT MAY NOT BE TRANSFERRED OR COPIED WITHOUT THE EXPRESS WRITTEN AUTHORIZATION OF DELL. IN ADDITION, NEITHER THIS SHEET NOR THE INFORMATION IT CONTAINS MAY BE USED BY OR DISCLOSED TO ANY THIRD PARTY WITHOUT DELL'S EXPRESS WRITTEN CONSENT.

DELL CONFIDENTIAL/PROPRIETARY			
Changed-List History 1/2			
Size	Document Number		Rev
	TOBAGO-LA2151		0.6
Date:	Wednesday, November 03, 2004		Sheet 50 of 51

Version Change List (P. I. R. List)

Item	Page#	Title	Date	Request Owner	Issue Description	Solution Description	Rev.
1	46	POWER	01/30	Demon	Change charger current	Change PR158 from 90.9K to 52.3K	0.1
2	44	POWER	01/30	Demon	Change DDR2 solution	Change PU6 from SC1486 to MAX8550 and other component at P44	0.1
3	42	POWER	01/30	Demon	Dell request to add components	Change PC15 from 4.7u to 2.2u, add PR203(100 ohm) and PC156(2.2u)	0.1
4	40	POWER	02/06	Demon	Dell request to change component	Change PR2 from 1.5k to 2.2k	0.1
5	43	POWER	02/13	Demon	Dell request to change component	Change PC51 from 330U 25m ohm to 330U 9m ohm	0.1
6	40	POWER	03/17	Demon	EMI request	Delete PL3 and pop PL2, add PL21 FBM-L11-453215-900LMAT_1812~D	0.2
7	45	POWER	03/17	Demon	EMI request	Change PR97,PR124 from 0 ohm to 2.2 ohm	0.2
8	44	POWER	03/17	Demon	Double Plus at high side gate	Add PC158 1000P	0.2
9	42	POWER	03/25	Demon	EMI request	Add PL22 FBM-L11-453215-900LMAT_1812~D	0.2
10	43	POWER	03/25	Demon	EMI request	Add PL23 FBM-L11-453215-900LMAT_1812~D	0.2
11	44	POWER	03/25	Demon	EMI request	Add PL24 FBM-L11-453215-900LMAT_1812~D	0.2
12	43	POWER	03/29	Demon	Increase 1.5VSUS voltage spec of power source for GMCH 1.5V Vcc power on Tobago	Change PR58 from 10K to 11K	0.2
13	40	POWER	04/05	Demon	DELL EE request	Change PQ1 from 2N7002 to BSS138	0.2
14	42	POWER	05/10	Demon	DELL power team request	Change PR27 from 4.7ohm to 10ohm, and add PR211 10ohm	0.3
15	46	POWER	05/10	Demon	DELL request	Change PU8 from MAX1535AETJ to MAX1535BETJ	0.3
16	44	POWER	05/14	Demon	For vender new version MAX8550A	Add PR212,PR215 0 ohm , and un-pop PQ36, PR197,PR213,PR214, and change PU6 from MAX8550 to MAX8550A	0.3
17	45	POWER	05/19	Demon	DELL request	Change PQ13,PQ17 from IRF7811AV to IRF7821 and PQ15,PQ19 from SI4362 to IRF7832 and un-pop PQ16,PQ20	0.3
18	44	POWER	05/31	Demon	DELL request	Change PC152, PC153, PC154,PC157 from 22uF to 10uF	0.3
19	48	POWER	05/31	Demon	Modify layout	Un-pop PQ15 and PQ17, pop PQ16 and PQ18	0.3
20	44	POWER	05/31	Demon	Modify schematic the same with Laguna and change switching frequencies from 450kHz to 300kHz	Un-pop PR84	0.3
21	43	POWER	06/07	Demon	DELL request, for MAX1845 negative voltage issue.	Add PQ37 2N7002 and PR216 33k ohm.	0.3
22	41	POWER	06/07	Demon	Modify 2.5V power sequence	Change PR1 from 0 ohm to 8.2k ohm and add PC8 0.1u.	0.3
23	43	POWER	06/10	Demon	Change 1.55V to 1.525V	Change PR58 from 11K to 10.5K.	0.3
24	44	POWER	06/10	Demon	For MAX8550	Add PQ36 and PR197 100k ohm, and delete PR212 0 ohm.	0.3
25	43	POWER	06/15	Demon	For power sequence	Pop PR60 and un-pop PR80 at External and Internal M/B.	0.3
26	43	POWER	07/08	Demon	For MAX1845 OVP issue	Add PR217 11k ohm.	0.4
27	45	POWER	07/08	Demon	For MAX1987 C4 Voltage	Add PR218 0 ohm and delete PR103 0 ohm and un-popPR219,PR220	0.4
28	45	POWER	07/21	Demon	For noise issue	Add a un-pop component PC159	0.4

PROPRIETARY NOTE: THIS SHEET OF ENGINEERING DRAWING AND SPECIFICATIONS CONTAINS CONFIDENTIAL TRADE SECRET AND OTHER PROPRIETARY INFORMATION OF DELL INC. ("DELL") THIS DOCUMENT MAY NOT BE TRANSFERRED OR COPIED WITHOUT THE EXPRESS WRITTEN AUTHORIZATION OF DELL. IN ADDITION, NEITHER THIS SHEET NOR THE INFORMATION IT CONTAINS MAY BE USED BY OR DISCLOSED TO ANY THIRD PARTY WITHOUT DELL'S EXPRESS WRITTEN CONSENT.

DELL CONFIDENTIAL/PROPRIETARY			
Changed-List History 1/2			
Size	Document Number		Rev
	TOBAGO-LA2151		0.6
Date:	Monday, October 18, 2004		Sheet 51 of 51