

Tonga & Tyler (T2)

VER : 1A

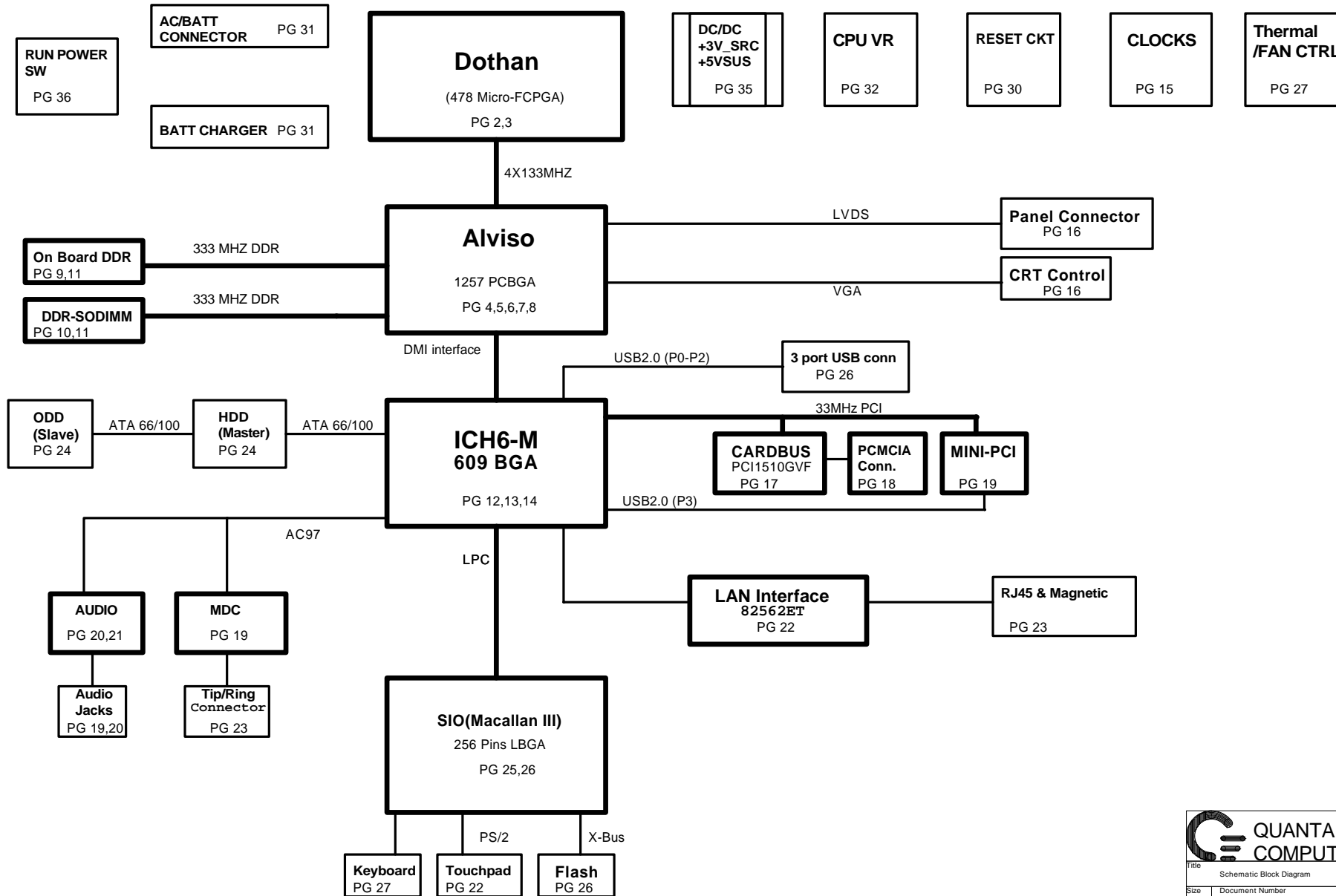

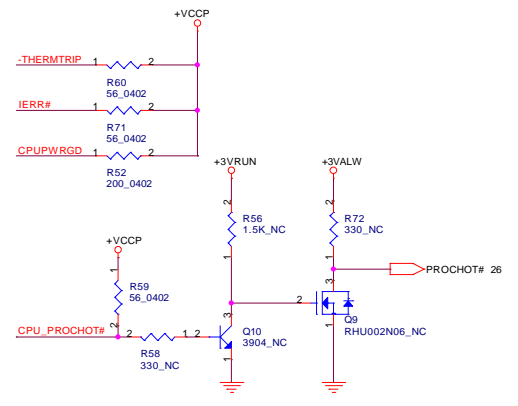
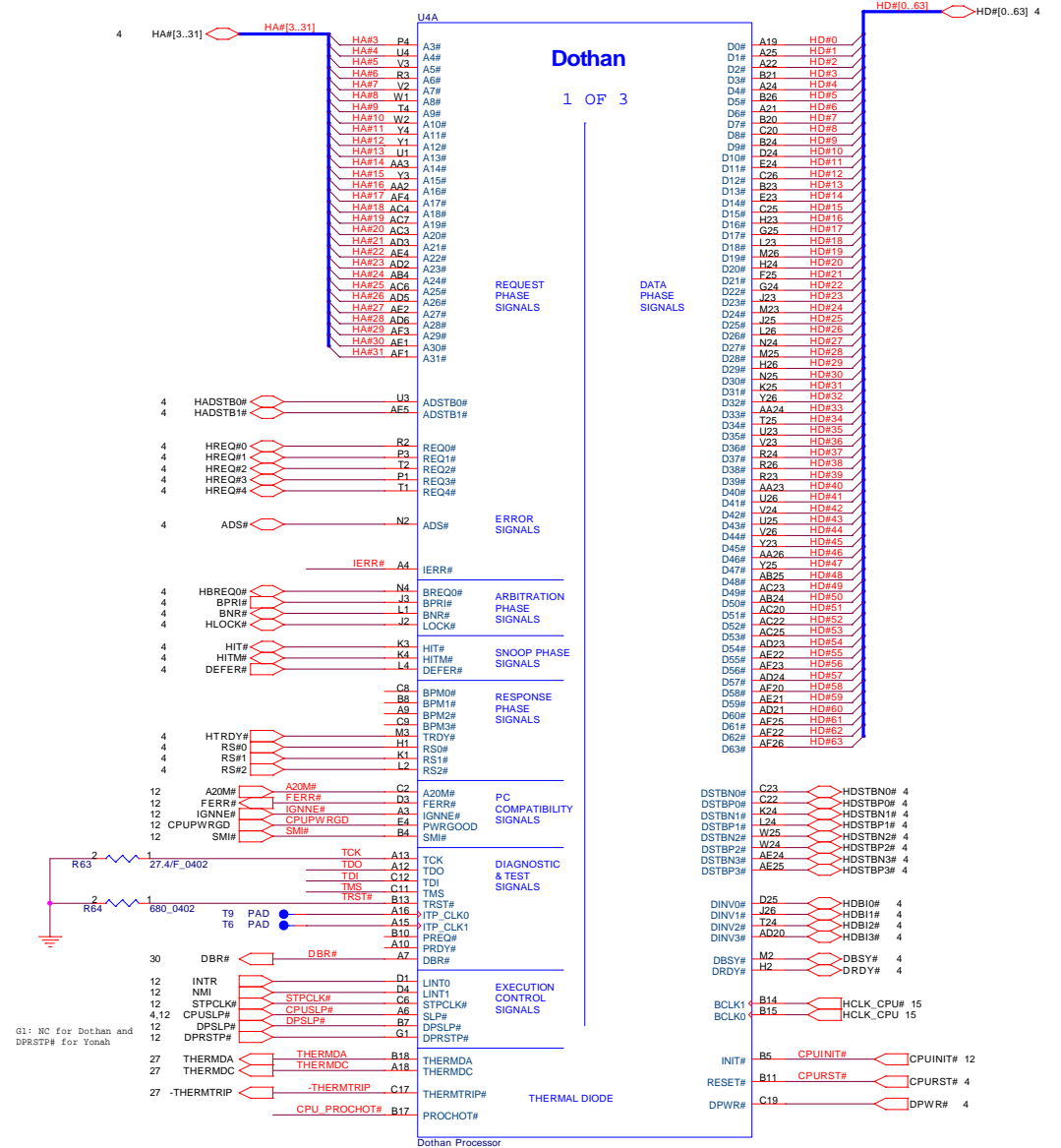

ITP disable guidelines

Signal	Resistor Value	Connect To	Resistor Placement
TDI	150 ohm +/- 5%	VCCP	Within 2.0" of the CPU
TMS	39 ohm +/- 5%	VCCP	Within 2.0" of the CPU
TRST#	680 ohm +/- 5%	GND	Within 2.0" of the CPU
TCK	27 ohm +/- 5%	GND	Within 2.0" of the CPU
TDO	Open	VCCP	Within 2.0" of the CPU

Note: Populate R178, R176, C339 when ITP connector is populated.

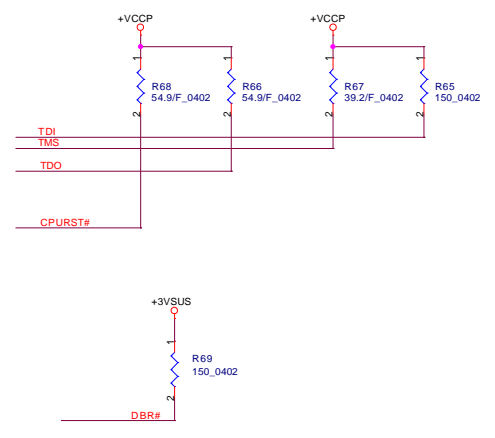

G1: NC for Dothan and DPRSTP# for Yonah

Dothan Processor

QUANTA COMPUTER

Title: Dothan Processor (Host BUS)

Size: Document Number VM7 Rev 1A

Date: Tuesday, August 17, 2004 Sheet 2 of 40

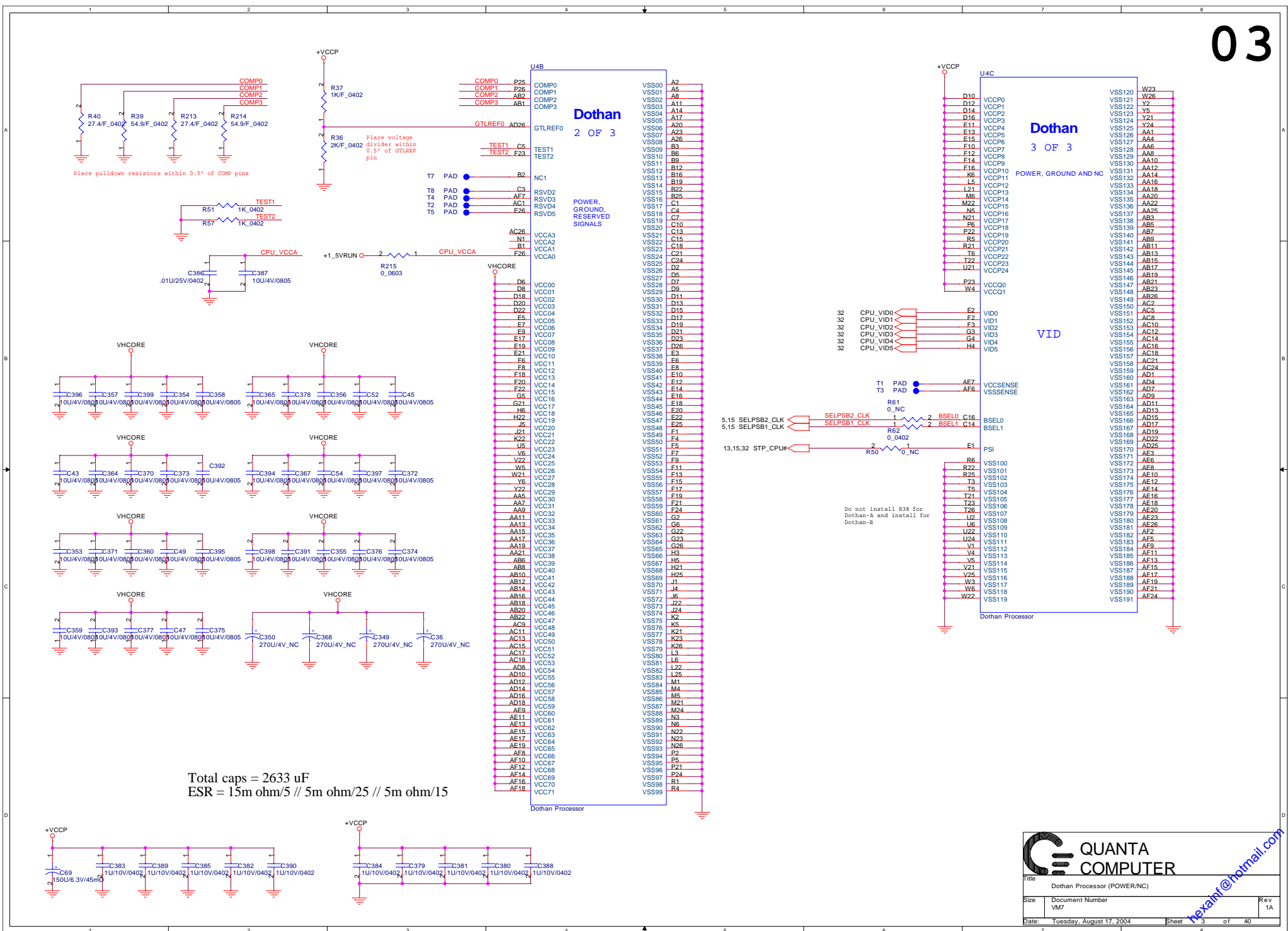

Total caps = 2633 uF
 ESR = 15m ohm/5 // 5m ohm/15

QUANTA COMPUTER

Title: Dothan Processor (POWER/NC)

Size	Document Number	Rev
	VM7	1A

Date: Tuesday, August 17, 2004 Sheet 3 of 40

hexant@hotmail.com

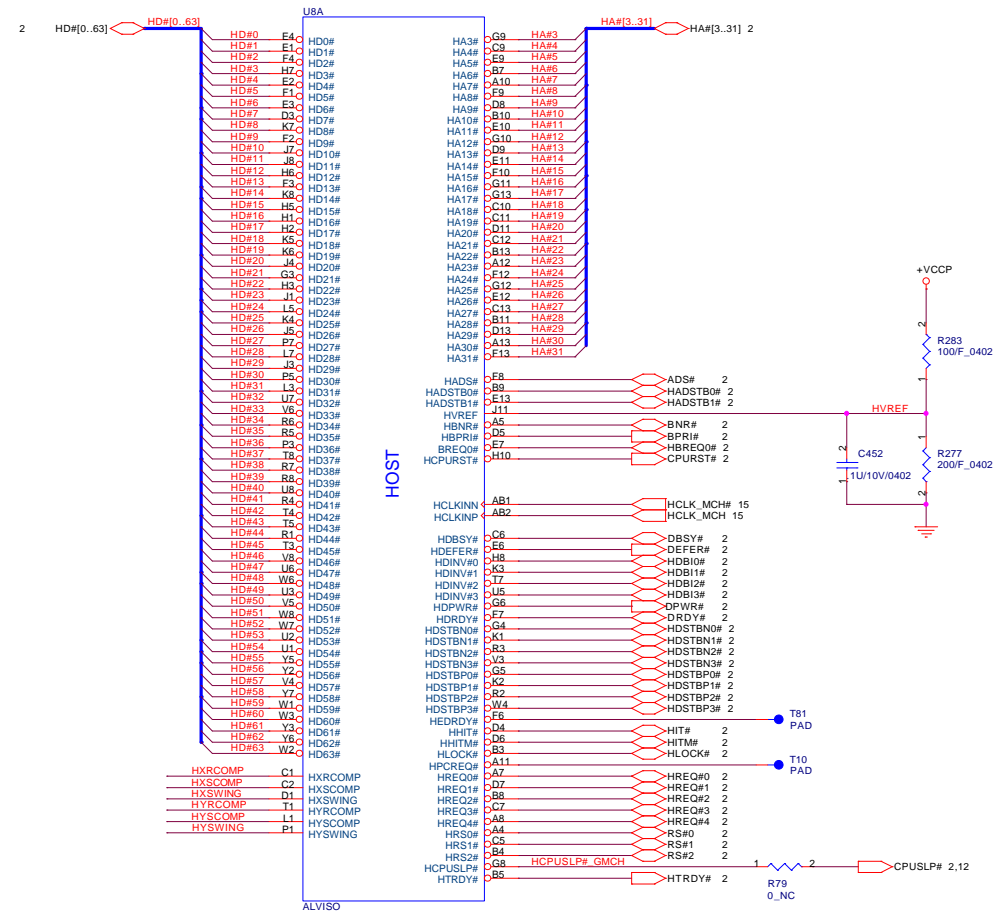
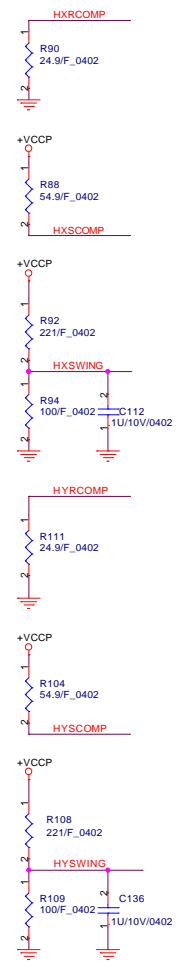

Do not install R51 for Dothan-A and install for Dothan-B

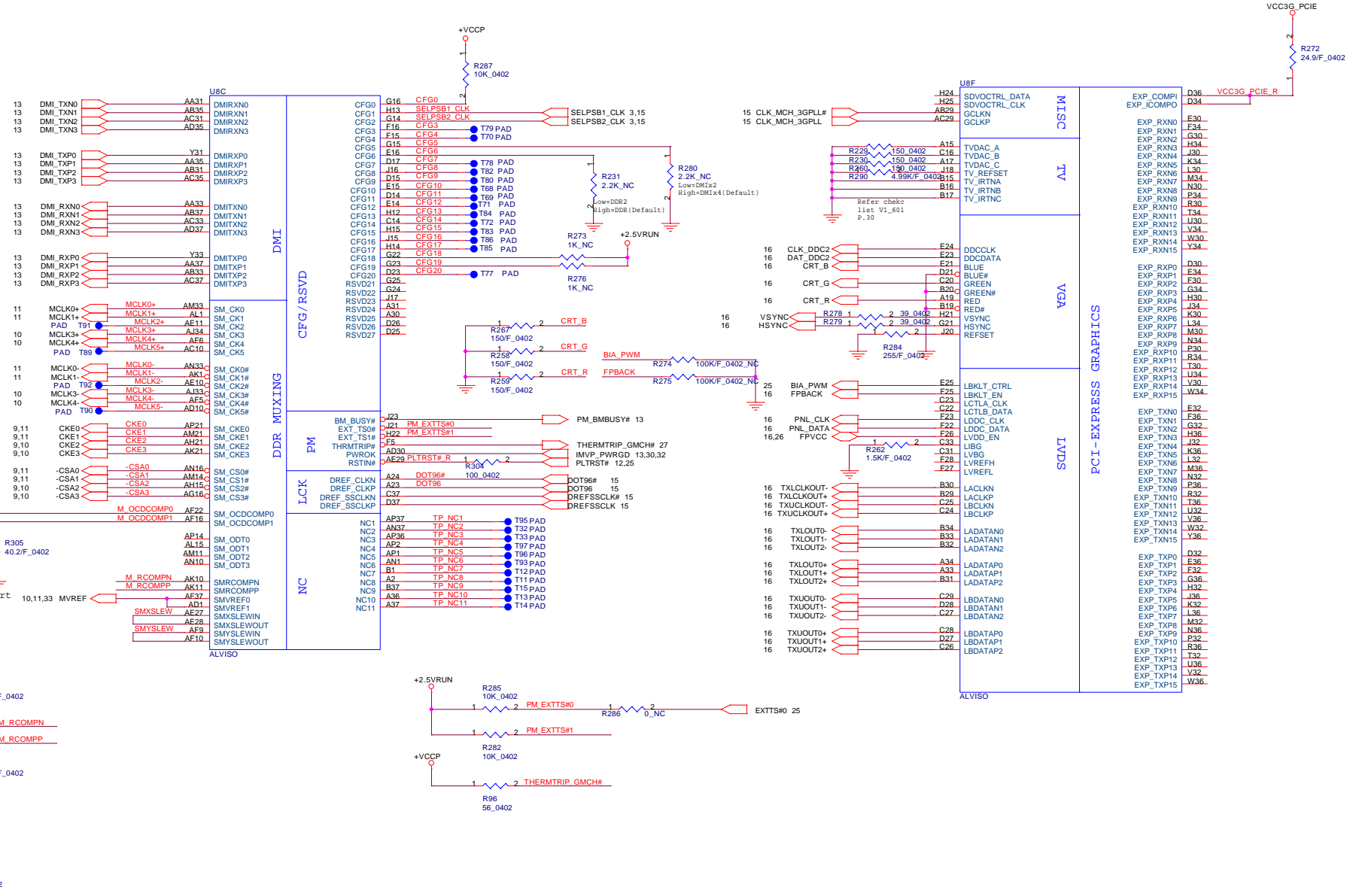

Route as short as possible.

Need to place these caps near Alviso SWRAP pins.

QUANTA COMPUTER

Title: Alviso (VGA,DMI)
 Schematic Number: VM7
 Date: Tuesday, August 17, 2004
 Sheet: 5 of 40
 Rev: 1A

hexant@hotmail.com

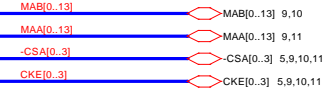
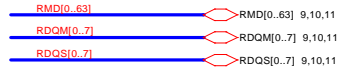

UBB

MD0	AC35	SAD00	SA_BS0#	AK15	A_BS0#	9,11
MD1	AH55	SAD01	SA_BS1#	AK16	A_BS1#	9,11
MD2	AL35	SAD02	SA_BS2#	AL21		
MD3	AL37	SAD03		AJ37	DOM0	
MD5	AJ35	SAD04	SA_DM0	AP35	DOM1	
MD6	AK37	SAD06	SA_DM2	AL29	DOM2	
MD7	AL34	SAD07	SA_DM3	AP24	DOM3	
MD8	AM36	SAD08	SA_DM4	AP9	DOM4	
MD9	AN35	SAD08	SA_DM4	AP4	DOM5	
MD10	AP32	SAD09	SA_DM5	AJ2	DOM6	
MD11	AM31	SAD010	SA_DM6	AD3	DOM7	
MD12	AM34	SAD011	SA_DM7	AD3		
MD13	AM35	SAD013	SA_DQ50	AK36	DO50	
MD14	AL32	SAD014	SA_DQ51	AP33	DO51	
MD15	AM32	SAD015	SA_DQ52	AN28	DO52	
MD16	AN31	SAD016	SA_DQ53	AP23	DO53	
MD17	AP31	SAD017	SA_DQ54	AM8	DO54	
MD18	AN28	SAD018	SA_DQ55	AM4	DO55	
MD19	AP28	SAD019	SA_DQ56	AJ1	DO56	
MD20	AL30	SAD020	SA_DQ57	AE5	DO57	
MD21	AM30	SAD021	SA_DQ50#	AK35		
MD22	AM28	SAD022	SA_DQ51#	AP34		
MD23	AL28	SAD022	SA_DQ51#	AN30		
MD24	AP27	SAD024	SA_DQ52#	AN23		
MD25	AM27	SAD025	SA_DQ53#	AN8		
MD26	AM23	SAD025	SA_DQ53#	AM5		
MD27	AM22	SAD027	SA_DQ55#	AH1		
MD28	AL23	SAD028	SA_DQ55#	AH1		
MD29	AM24	SAD028	SA_DQ57#	AE4		
MD30	AN22	SAD029	SA_DQ57#	AE4		
MD31	AP22	SAD030	SA_MA0	AL17	MAA0	
MD32	AM9	SAD031	SA_MA1	AP18	MAA1	
MD33	AL9	SAD032	SA_MA2	AP17	MAA2	
MD34	AL6	SAD034	SA_MA3	AM17	MAA3	
MD35	AP7	SAD035	SA_MA4	AM18	MAA4	
MD36	AP11	SAD036	SA_MA5	AH8	MAA5	
MD37	AP10	SAD036	SA_MA5	AL19	MAA6	
MD38	AM7	SAD037	SA_MA6	AP20	MAA7	
MD39	AL7	SAD038	SA_MA7	AM19	MAA8	
MD40	AN5	SAD039	SA_MA8	AL20	MAA9	
MD41	AN6	SAD040	SA_MA9	AM16	MAA10	
MD42	AN3	SAD041	SA_MA10	AN20	MAA11	
MD43	AP3	SAD042	SA_MA11	AJ4	MAA12	
MD44	AP6	SAD043	SA_MA12	AH5	MAA13	
MD45	AM6	SAD044	SA_MA13	AM15	MAA13	
MD46	AL4	SAD045	SA_CAS#	AK15	DCASA	9,11
MD47	AM3	SAD046	SA_RAS#	AP16	DRASA	9,11
MD48	AK2	SAD047	SA_RAS#	AP16	DRASA	9,11
MD49	AK3	SAD048	SA_RCVENIN#	AF29		
MD50	AG2	SAD049	SA_RCVENOUT#	AF28		
MD51	AG1	SAD050	SA_WE#	AP15	DMWA	9,11
MD52	AL3	SAD051				
MD53	AM2	SAD052				
MD54	AH3	SAD053				
MD55	AG3	SAD054				
MD56	AF3	SAD055				
MD57	AD6	SAD056				
MD58	AD6	SAD057				
MD59	AC4	SAD058				
MD60	AF2	SAD059				
MD61	AE1	SAD060				
MD62	AD4	SAD061				
MD63	AD5	SAD062				
		SAD063				

ALVISO

UBG

AE31	SBD00	SB_BS0#	AJ15	B_BS0#	9,10
AE32	SBD01	SB_BS1#	AG17	B_BS1#	9,10
AG32	SBD02	SB_BS2#	AG21		
AG36	SBD03	SB_BS2#			
AE34	SBD04	SB_DM0	AF32		
AE33	SBD05	SB_DM1	AK34		
AF31	SBD06	SB_DM2	AK27		
AE30	SBD07	SB_DM3	AK24		
AH33	SBD08	SB_DM4	AJ10		
AH32	SBD09	SB_DM5	AK5		
AK31	SBD10	SB_DM6	AE7		
AG30	SBD10	SB_DM7	AB7		
AG34	SBD11	SB_DM7			
AG33	SBD12	SB_DQ50	AE34		
AH31	SBD13	SB_DQ51	AK32		
AJ31	SBD14	SB_DQ52	AJ28		
AK30	SBD15	SB_DQ53	AK23		
AJ30	SBD16	SB_DQ34	AM10		
AH29	SBD17	SB_DQ35	AH6		
AH28	SBD18	SB_DQ36	AF8		
AK29	SBD19	SB_DQ37	AB4		
AH30	SBD20	SB_DQ37			
AH27	SBD21	SB_DQ50#	AE35		
AG28	SBD22	SB_DQ51#	AK33		
AG23	SBD23	SB_DQ52#	AK28		
AJ22	SBD24	SB_DQ53#	AJ23		
AK22	SBD25	SB_DQ54#	AL10		
AH24	SBD26	SB_DQ55#	AH7		
AH23	SBD27	SB_DQ55#	AF7		
AG22	SBD28	SB_DQ57#	AB5		
AG22	SBD29	SB_DQ57#			
AG22	SBD30				
AG10	SBD31	SB_MA0	AH17	MAB0	
AG9	SBD32	SB_MA1	AK17	MAB1	
AG8	SBD33	SB_MA2	AH18	MAB2	
AG8	SBD34	SB_MA3	AJ18	MAB3	
AH11	SBD35	SB_MA4	AK18	MAB4	
AH10	SBD36	SB_MA5	AJ19	MAB5	
AJ9	SBD37	SB_MA6	AK19	MAB6	
AK9	SBD38	SB_MA7	AH19	MAB7	
AJ7	SBD39	SB_MA8	AJ20	MAB8	
AH6	SBD40	SB_MA9	AH20	MAB9	
AJ4	SBD41	SB_MA10	AJ16	MAB10	
AH5	SBD42	SB_MA11	AG18	MAB11	
AK5	SBD43	SB_MA12	AG20	MAB12	
AJ8	SBD44	SB_MA13	AG15	MAB13	
AJ8	SBD45	SB_CAS#	AH14	DCASB	9,10
AK4	SBD46	SB_RAS#	AK14	DRASB	9,10
AG5	SBD47	SB_RCVENIN#	AE13		
AG4	SBD48	SB_RCVENOUT#	AF14		
AD9	SBD49	SB_WE#	AH16	DMWB	9,10
AD9	SBD50				
AH4	SBD51				
AG6	SBD52				
AE8	SBD53				
AD7	SBD54				
AC5	SBD55				
AB8	SBD56				
AB6	SBD57				
AA8	SBD58				
AC8	SBD59				
AC7	SBD60				
AA4	SBD61				
AA5	SBD62				
AA5	SBD63				

ALVISO

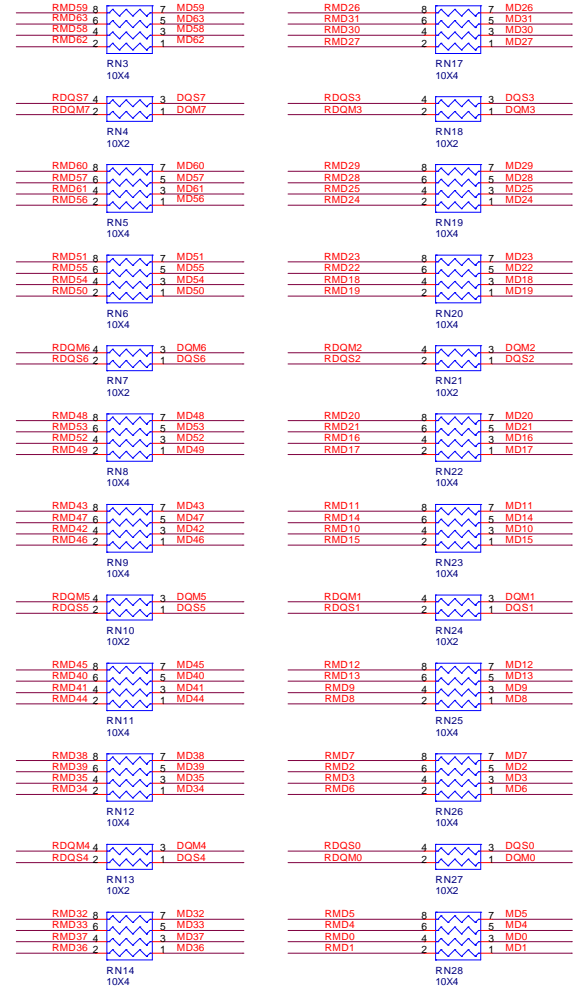

U8D
ALVISO NCTF

L17	VCC_NCTF78	Y12
N17	VCC_NCTF76	AA2
L17	VCC_NCTF75	Y13
T17	VCC_NCTF74	AA3
U17	VCC_NCTF73	AA4
W17	VCC_NCTF72	AA5
L18	VCC_NCTF71	R14
M18	VCC_NCTF69	T14
P18	VCC_NCTF68	AA1
R18	VCC_NCTF66	AA2
L19	VCC_NCTF65	AA3
M19	VCC_NCTF64	AA4
N19	VCC_NCTF62	AA5
R19	VCC_NCTF61	N15
Y19	VCC_NCTF59	P15
M20	VCC_NCTF58	T15
P20	VCC_NCTF56	AA1
Y20	VCC_NCTF54	AA2
L21	VCC_NCTF52	AA3
N21	VCC_NCTF51	AA4
P21	VCC_NCTF48	AA5
U21	VCC_NCTF46	AA1
W21	VCC_NCTF44	AA2
L22	VCC_NCTF42	AA3
R22	VCC_NCTF41	AA4
T22	VCC_NCTF38	AA5
W22	VCC_NCTF37	R17
L23	VCC_NCTF35	AA1
N23	VCC_NCTF34	AA2
P23	VCC_NCTF31	AA3
U23	VCC_NCTF30	AA4
V23	VCC_NCTF28	AA5
L24	VCC_NCTF27	E21
M24	VCC_NCTF25	AA1
P24	VCC_NCTF24	AA2
R24	VCC_NCTF22	AA3
U24	VCC_NCTF20	AA4
W24	VCC_NCTF18	AA5
M25	VCC_NCTF17	AA1
P25	VCC_NCTF15	AA2
R25	VCC_NCTF14	AA3
T25	VCC_NCTF13	AA4
U25	VCC_NCTF11	AA5
W25	VCC_NCTF10	AA1
L26	VCC_NCTF8	AA2
N26	VCC_NCTF7	AA3
P26	VCC_NCTF6	AA4
R26	VCC_NCTF4	AA5
U26	VCC_NCTF3	AA1
W26	VCC_NCTF1	AA2
W28	VCC_NCTF0	AA3
AB12	VCCSM_NCTF31	
AD12	VCCSM_NCTF30	
AB13	VCCSM_NCTF28	
AC13	VCCSM_NCTF27	
AC14	VCCSM_NCTF26	
AD14	VCCSM_NCTF24	
AD15	VCCSM_NCTF23	
AC16	VCCSM_NCTF22	
AD16	VCCSM_NCTF19	
AD17	VCCSM_NCTF17	
AC18	VCCSM_NCTF16	
AC19	VCCSM_NCTF14	
AD19	VCCSM_NCTF13	
AD20	VCCSM_NCTF12	
AC21	VCCSM_NCTF11	
AD21	VCCSM_NCTF10	
AD22	VCCSM_NCTF9	
AC23	VCCSM_NCTF7	
AC24	VCCSM_NCTF6	
AC25	VCCSM_NCTF5	
AC26	VCCSM_NCTF3	
AC28	VCCSM_NCTF2	
AD28	VCCSM_NCTF0	
VT1	NCTF17	L12
VT2	NCTF16	M12
VT3	NCTF15	L13
VT4	NCTF14	M12
VT5	NCTF13	T12
VT6	NCTF12	L12
VT7	NCTF11	M12
VT8	NCTF10	L13
VT9	NCTF9	M13
VT10	NCTF7	M13
VT11	NCTF6	P13
VT12	NCTF4	P13
VT13	NCTF3	L13
VT14	NCTF2	M13
VT15	NCTF0	M13

+VCCP

+2.5VSUS

+VCCP



U8E
ALVISO VSS

B24	VSS195	Y1
D24	VSS194	D2
L24	VSS193	D2
AG24	VSS191	AL24
E24	VSS190	AL24
G24	VSS188	A24
H24	VSS187	G28
A27	VSS186	L2
B27	VSS185	L2
C27	VSS184	L2
D27	VSS183	L2
E27	VSS182	L2
F27	VSS181	L2
G27	VSS180	L2
H27	VSS179	L2
A27	VSS178	L2
B27	VSS177	L2
C27	VSS176	L2
D27	VSS175	L2
E27	VSS174	L2
F27	VSS173	L2
G27	VSS172	L2
H27	VSS171	L2
A28	VSS170	L2
B28	VSS169	L2
C28	VSS168	L2
D28	VSS167	L2
E28	VSS166	L2
F28	VSS165	L2
G28	VSS164	L2
H28	VSS163	L2
A29	VSS162	L2
B29	VSS161	L2
C29	VSS160	L2
D29	VSS159	L2
E29	VSS158	L2
F29	VSS157	L2
G29	VSS156	L2
H29	VSS155	L2
A30	VSS154	L2
B30	VSS153	L2
C30	VSS152	L2
D30	VSS151	L2
E30	VSS150	L2
F30	VSS149	L2
G30	VSS148	L2
H30	VSS147	L2
A31	VSS146	L2
B31	VSS145	L2
C31	VSS144	L2
D31	VSS143	L2
E31	VSS142	L2
F31	VSS141	L2
G31	VSS140	L2
H31	VSS139	L2
A32	VSS138	L2
B32	VSS137	L2
C32	VSS136	L2
D32	VSS135	L2
E32	VSS134	L2
F32	VSS133	L2
G32	VSS132	L2
H32	VSS131	L2
A33	VSS130	L2
B33	VSS129	L2
C33	VSS128	L2
D33	VSS127	L2
E33	VSS126	L2
F33	VSS125	L2
G33	VSS124	L2
H33	VSS123	L2
A34	VSS122	L2
B34	VSS121	L2
C34	VSS120	L2
D34	VSS119	L2
E34	VSS118	L2
F34	VSS117	L2
G34	VSS116	L2
H34	VSS115	L2
A35	VSS114	L2
B35	VSS113	L2
C35	VSS112	L2
D35	VSS111	L2
E35	VSS110	L2
F35	VSS109	L2
G35	VSS108	L2
H35	VSS107	L2
A36	VSS106	L2
B36	VSS105	L2
C36	VSS104	L2
D36	VSS103	L2
E36	VSS102	L2
F36	VSS101	L2
G36	VSS100	L2
H36	VSS99	L2
A37	VSS98	L2
B37	VSS97	L2
C37	VSS96	L2
D37	VSS95	L2
E37	VSS94	L2
F37	VSS93	L2
G37	VSS92	L2
H37	VSS91	L2
A38	VSS90	L2
B38	VSS89	L2
C38	VSS88	L2
D38	VSS87	L2
E38	VSS86	L2
F38	VSS85	L2
G38	VSS84	L2
H38	VSS83	L2
A39	VSS82	L2
B39	VSS81	L2
C39	VSS80	L2
D39	VSS79	L2
E39	VSS78	L2
F39	VSS77	L2
G39	VSS76	L2
H39	VSS75	L2
A40	VSS74	L2
B40	VSS73	L2
C40	VSS72	L2
D40	VSS71	L2
E40	VSS70	L2
F40	VSS69	L2
G40	VSS68	L2
H40	VSS67	L2
A41	VSS66	L2
B41	VSS65	L2
C41	VSS64	L2
D41	VSS63	L2
E41	VSS62	L2
F41	VSS61	L2
G41	VSS60	L2
H41	VSS59	L2
A42	VSS58	L2
B42	VSS57	L2
C42	VSS56	L2
D42	VSS55	L2
E42	VSS54	L2
F42	VSS53	L2
G42	VSS52	L2
H42	VSS51	L2
A43	VSS50	L2

D

C

B

A

D

C

B

A

QUANTA COMPUTER

Title	Alviso (VSS/NC)	Rev	1A
Size	Document Number VM7		
Date:	Tuesday, August 17, 2004	Sheet	8 of 40

DDR TERMINATOR

09

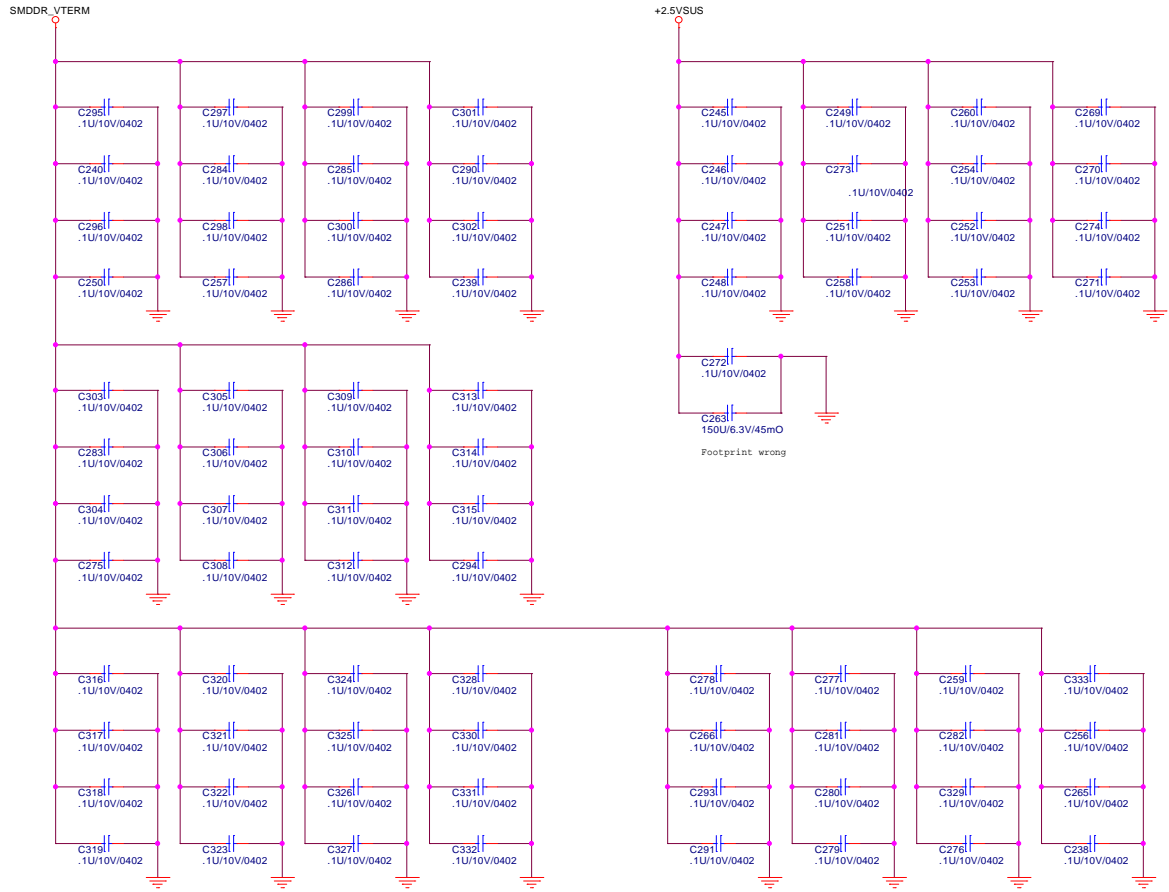
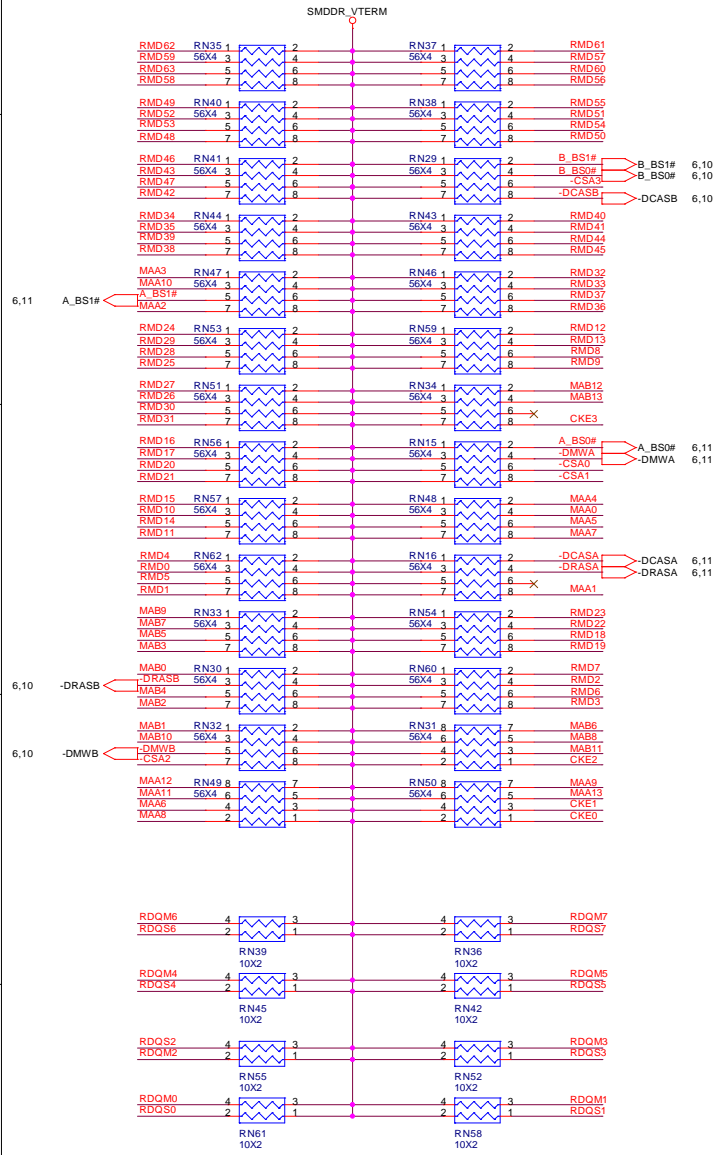
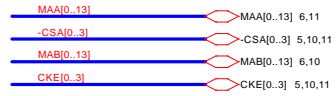

QUANTA COMPUTER

Title: **DDR Terminators**

Size: Custom Document Number: Trend Mark Rev: 1A

Date: Tuesday, August 17, 2004 Sheet: 9 of 40

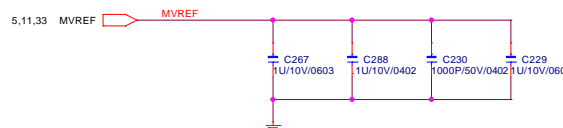
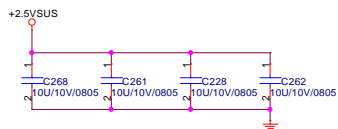
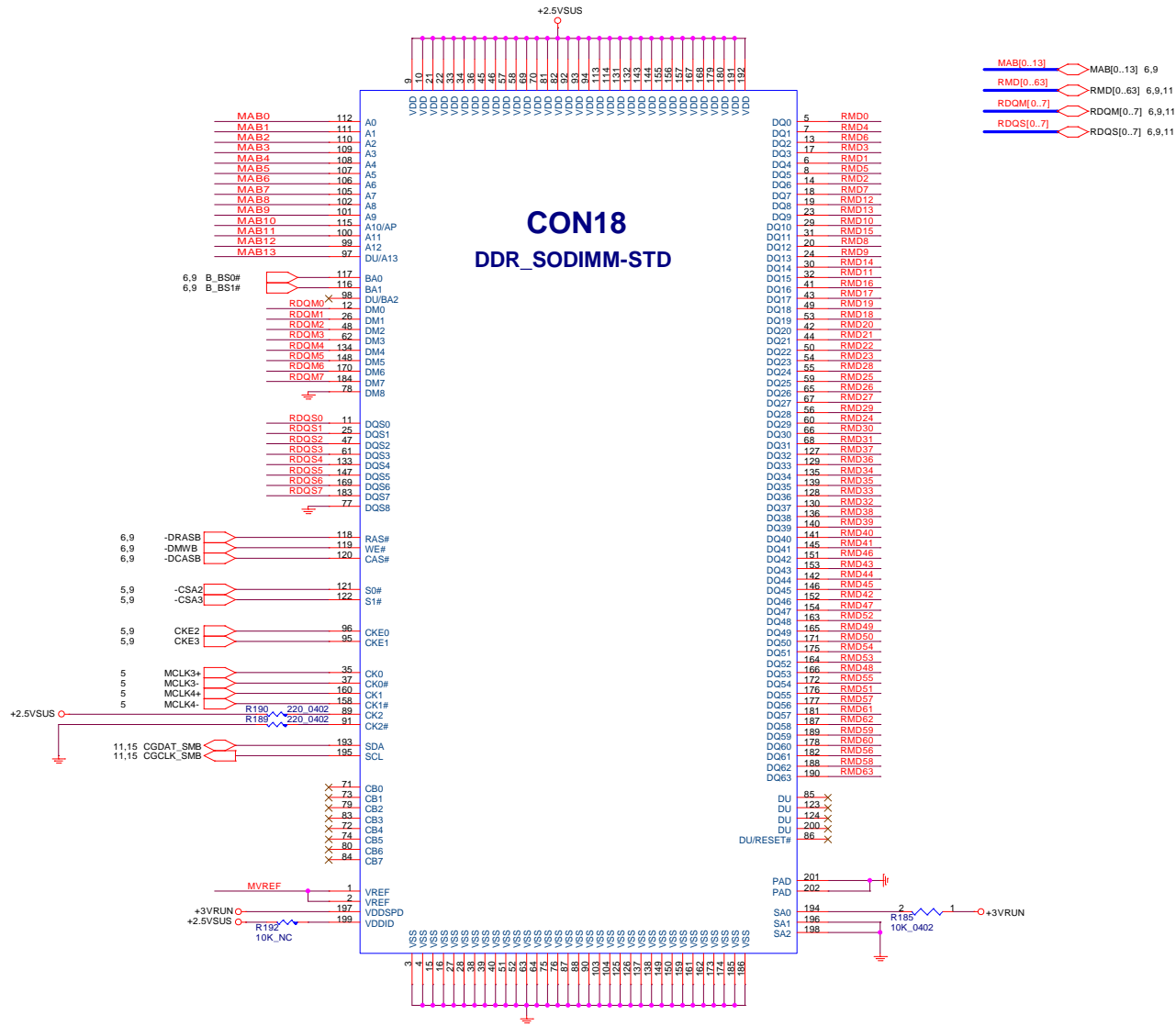

QUANTA COMPUTER

File: **Memory - SODIMM**

Size: Custom Document Number

Rev: 1A

Date: Tuesday, August 17, 2004 Sheet 10 of 40

- 6.9 MAA[0..13]
- 6.9,10 RMD[0..63]
- 6.9,10 RDQS[0..7]
- 6.9,10 RDQM[0..7]

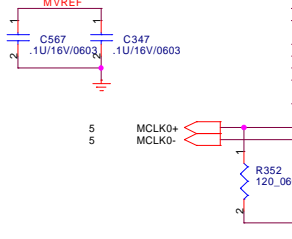
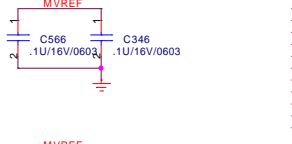

- 6.9 A_BSO#
- 6.9 A_BST1#
- 6.9 MVREF
- 6.9 -DRASA
- 6.9 -DMWA
- 6.9 -DCASA
- 6.9 -CSA0
- 5.9 -CSA1
- 5.9 CKE0
- 5.5 CKE1

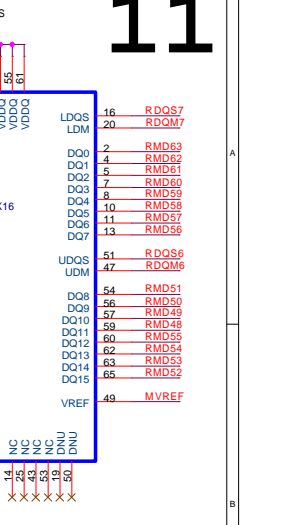
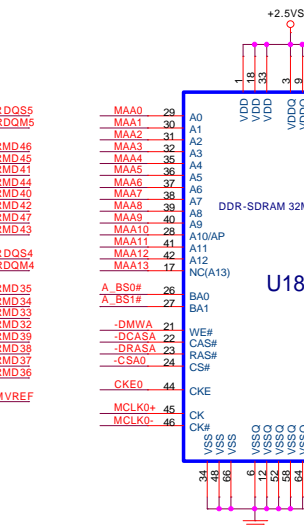
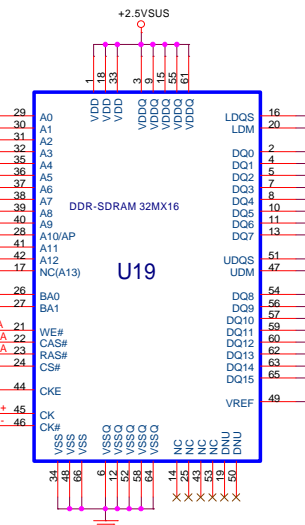
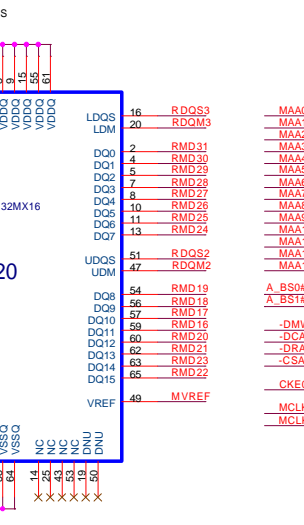
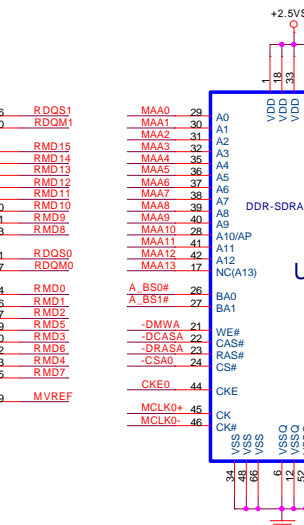
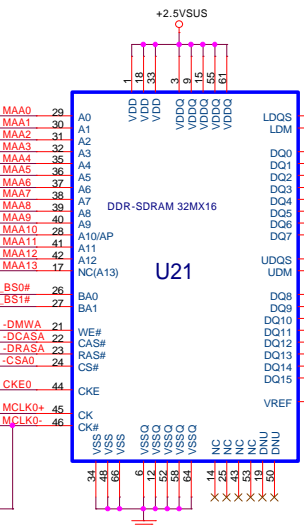
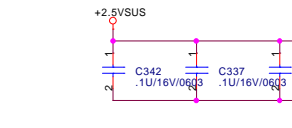
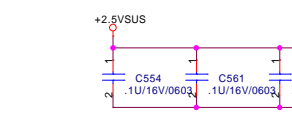
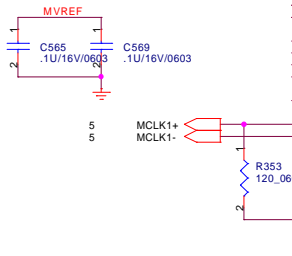
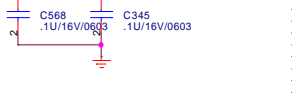

For on board memory SPD data

QUANTA COMPUTER

File: **DDR (on board)**

Size: Custom Document Number

Rev: 1A

Date: Tuesday, August 17, 2004 Sheet 11 of 40

Trend Micro

hexant@hotmail.com

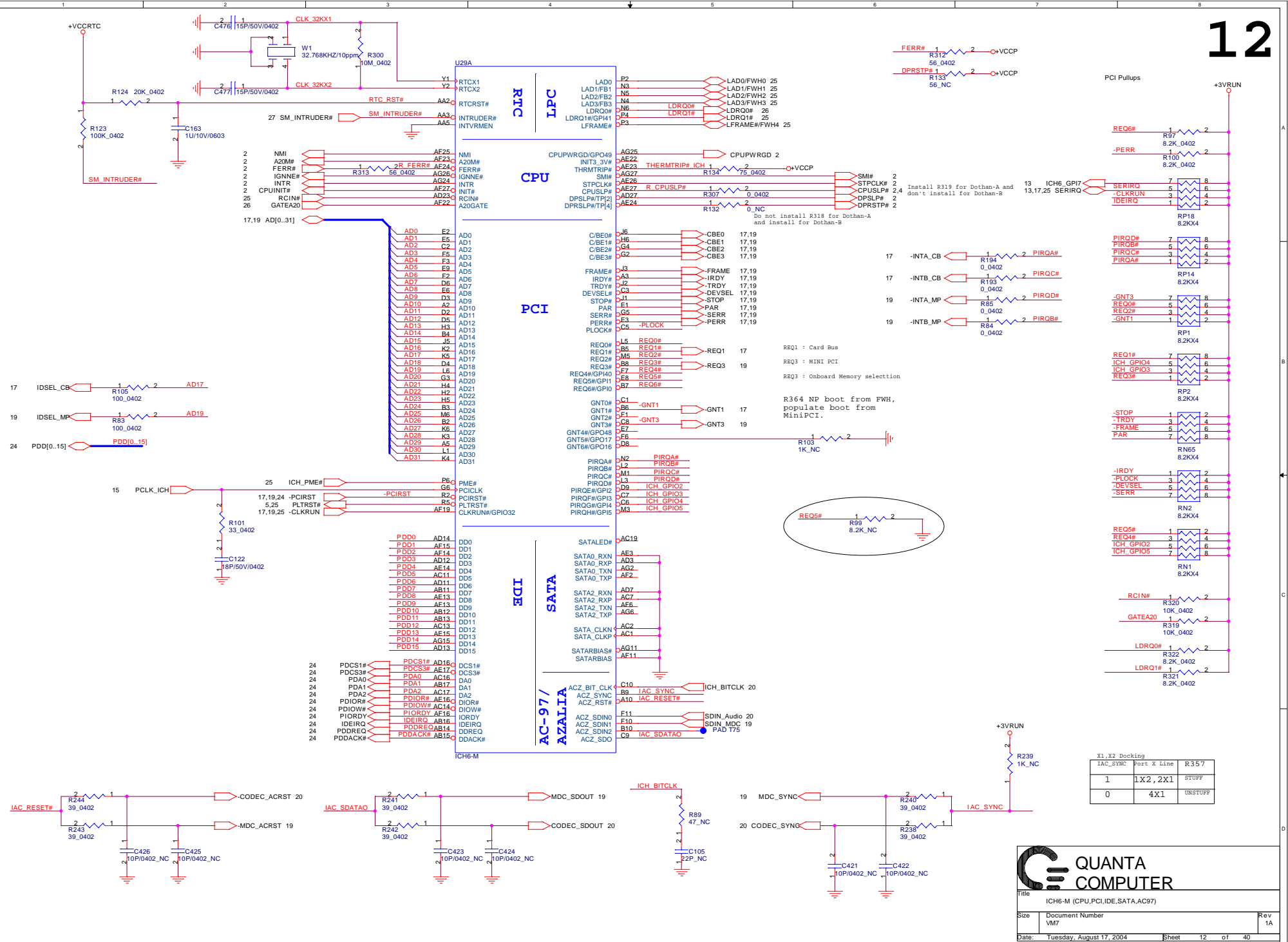

X1, X2 Docking

IAC_SYNC	Port X Line	R357
1	1X2, 2X1	STUFF
0	4X1	UNSTUFF

QUANTA COMPUTER

Title: ICH6-M (CPU, PCI, IDE, SATA, AC97)

Size: Document Number VM7

Date: Tuesday, August 17, 2004

Sheet 12 of 40

Rev 1A

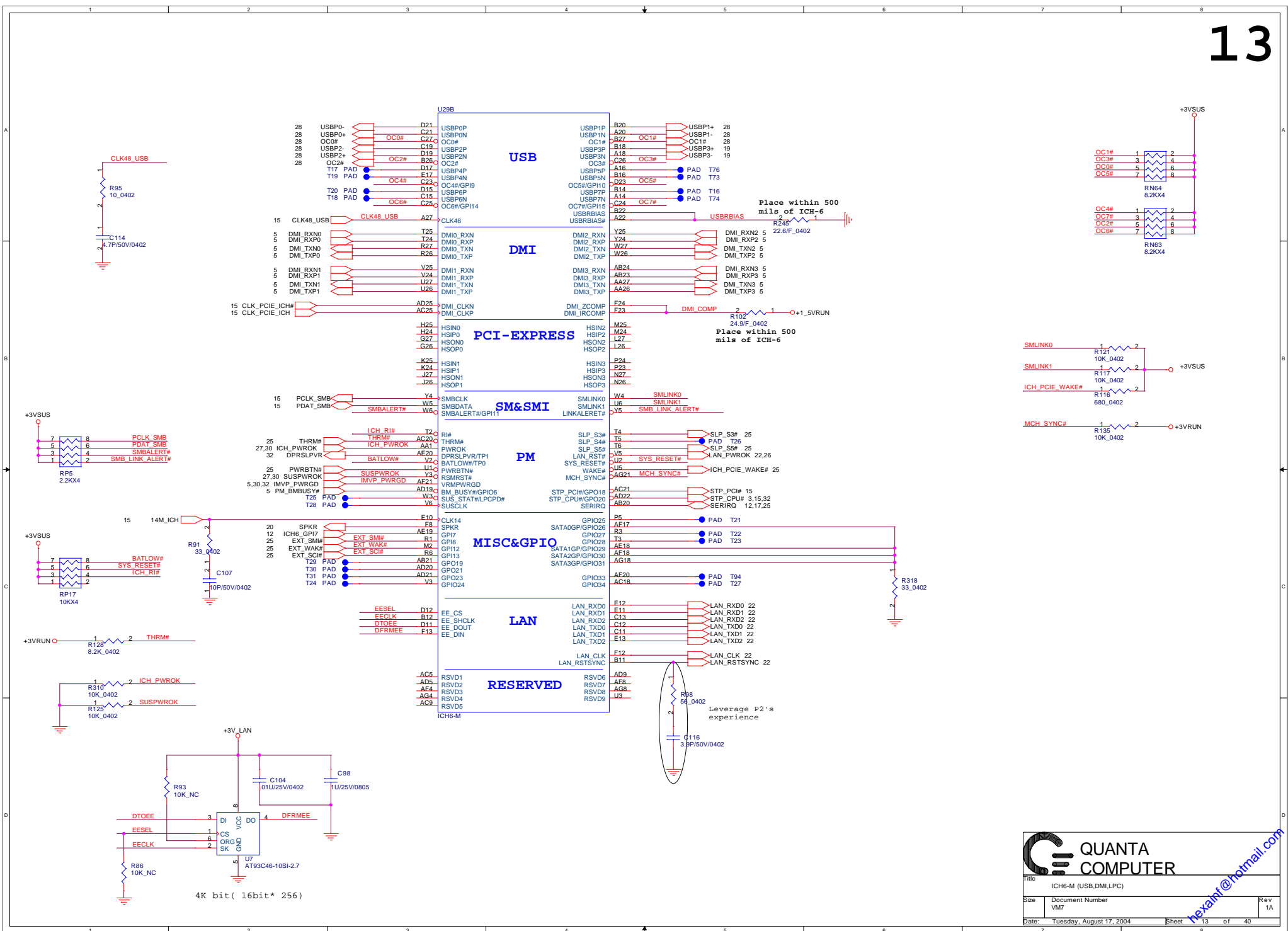

QUANTA COMPUTER

Title: ICH6-M (USB,DMI,LPC)

Size: Document Number VM7 Rev 1A

Date: Tuesday, August 17, 2004 Sheet 13 of 40

hexant@hotmail.com

FSC	FSB	FSA	CPU	SRC	PCI
1	0	1	100	100	33
0	0	1	133	100	33
0	1	1	166	100	33
0	1	0	200	100	33
0	0	0	266	100	33
1	0	0	333	100	33
1	1	0	400	100	33
1	1	1	RSVD	100	33

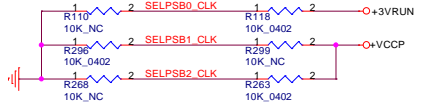

Depop R299 for Dothan-B

Place these termination to close CK410M.

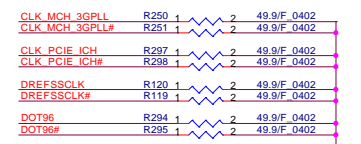
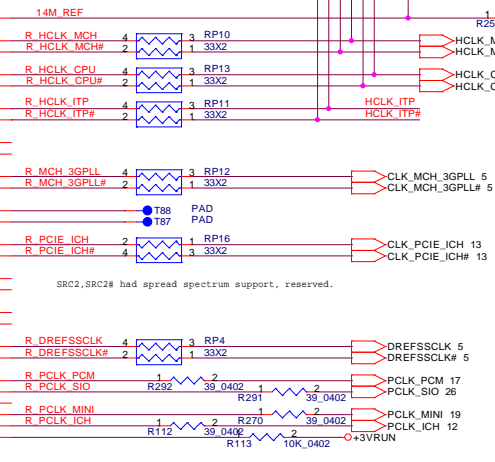
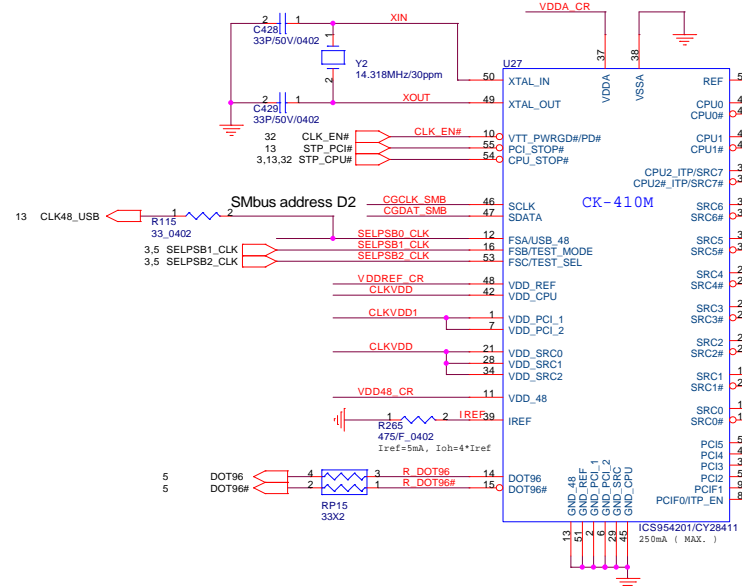
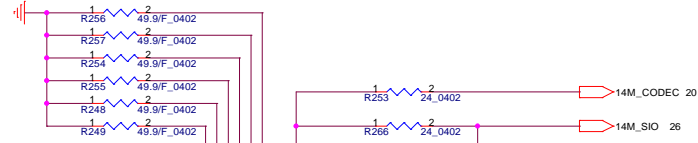

Place these termination to close CK410M.

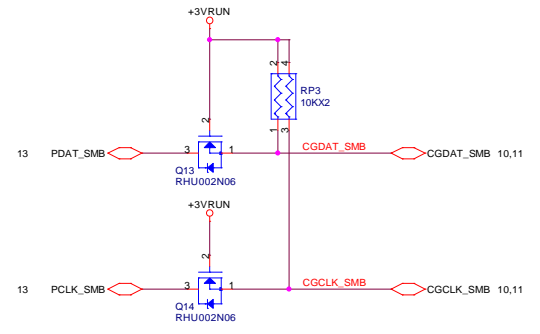
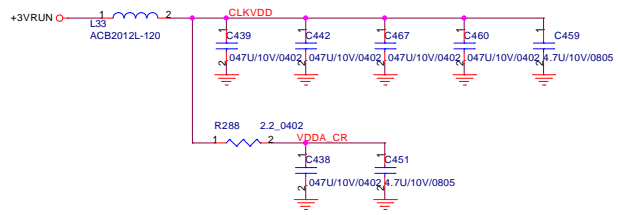
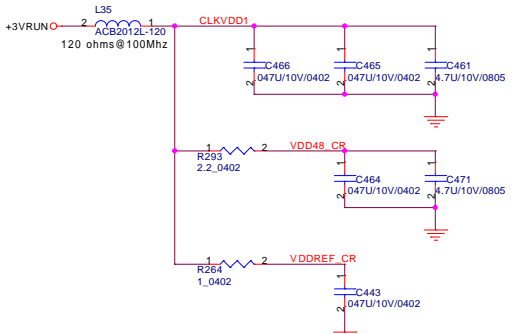

These are for backdrive issue

**QUANTA
COMPUTER**

Title: CLOCK GENERATOR		
Size: VM7	Document Number: VM7	Rev: 1A
Date: Tuesday, August 17, 2004	Sheet: 15 of 40	

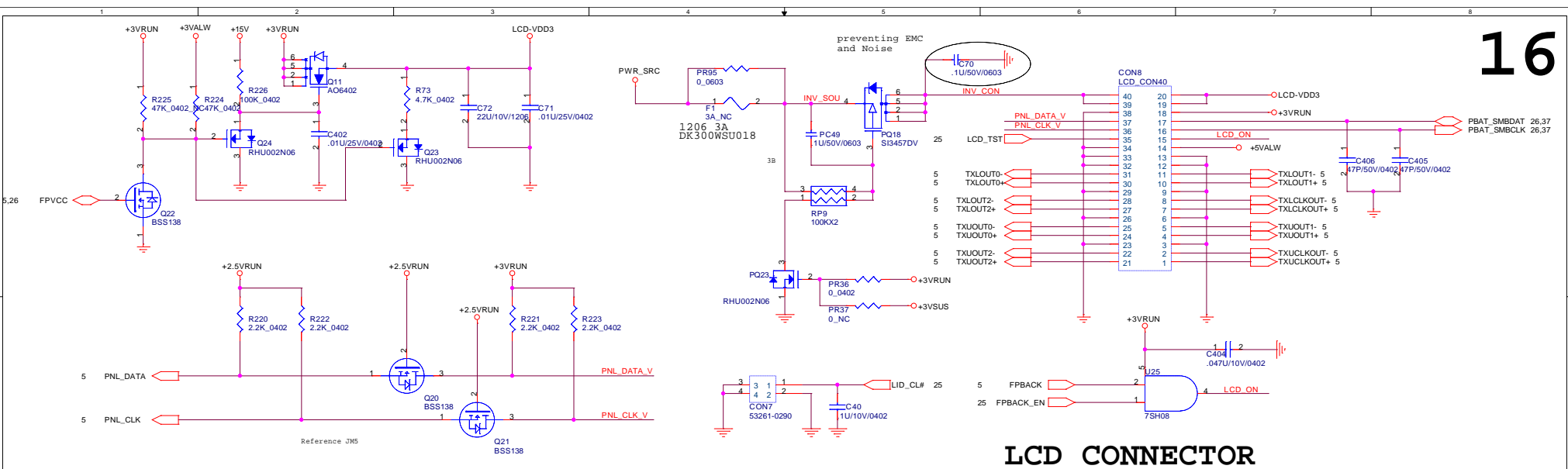

LCD CONNECTOR

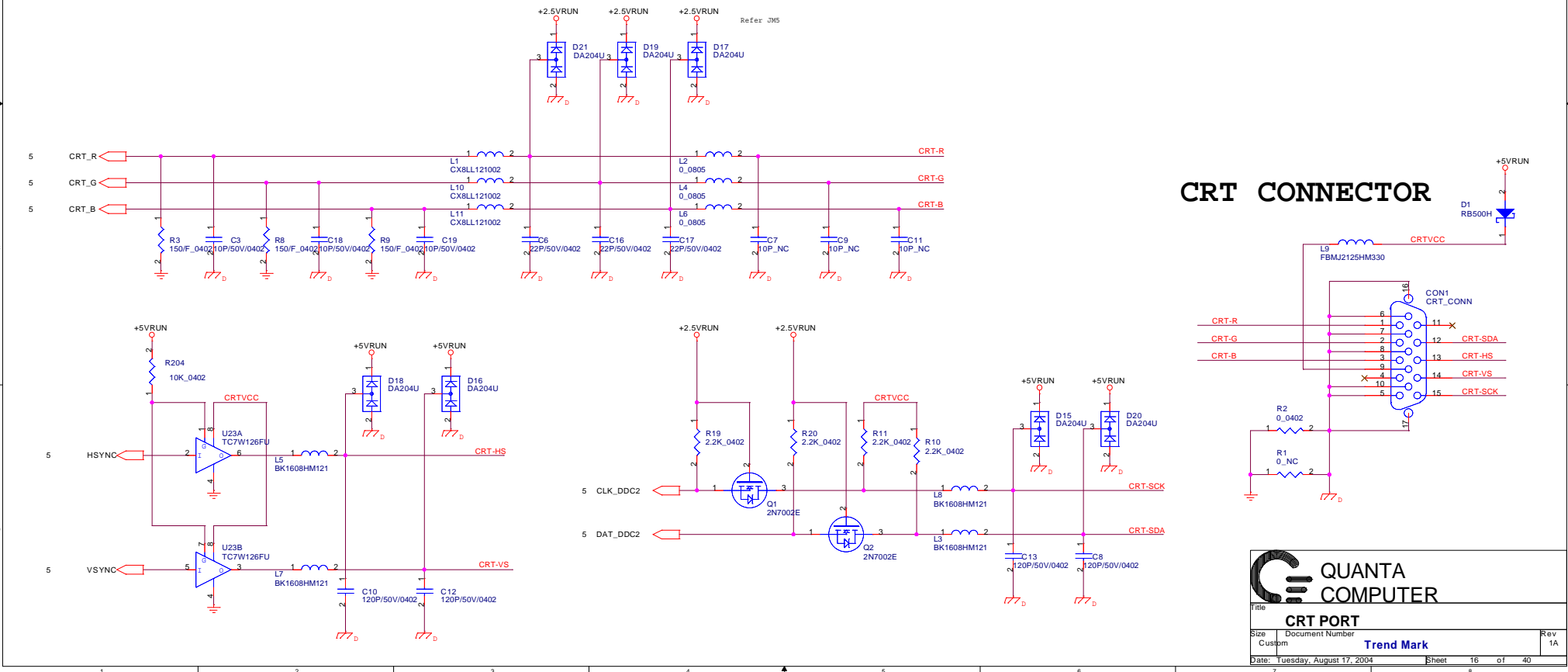

CRT CONNECTOR

QUANTA COMPUTER

CRT PORT

Size: Custom Document Number: Trend Mark Rev: 1A

Date: Tuesday, August 17, 2004 Sheet: 16 of 40

PCAD[0..15] 18
PCAA[0..25] 18

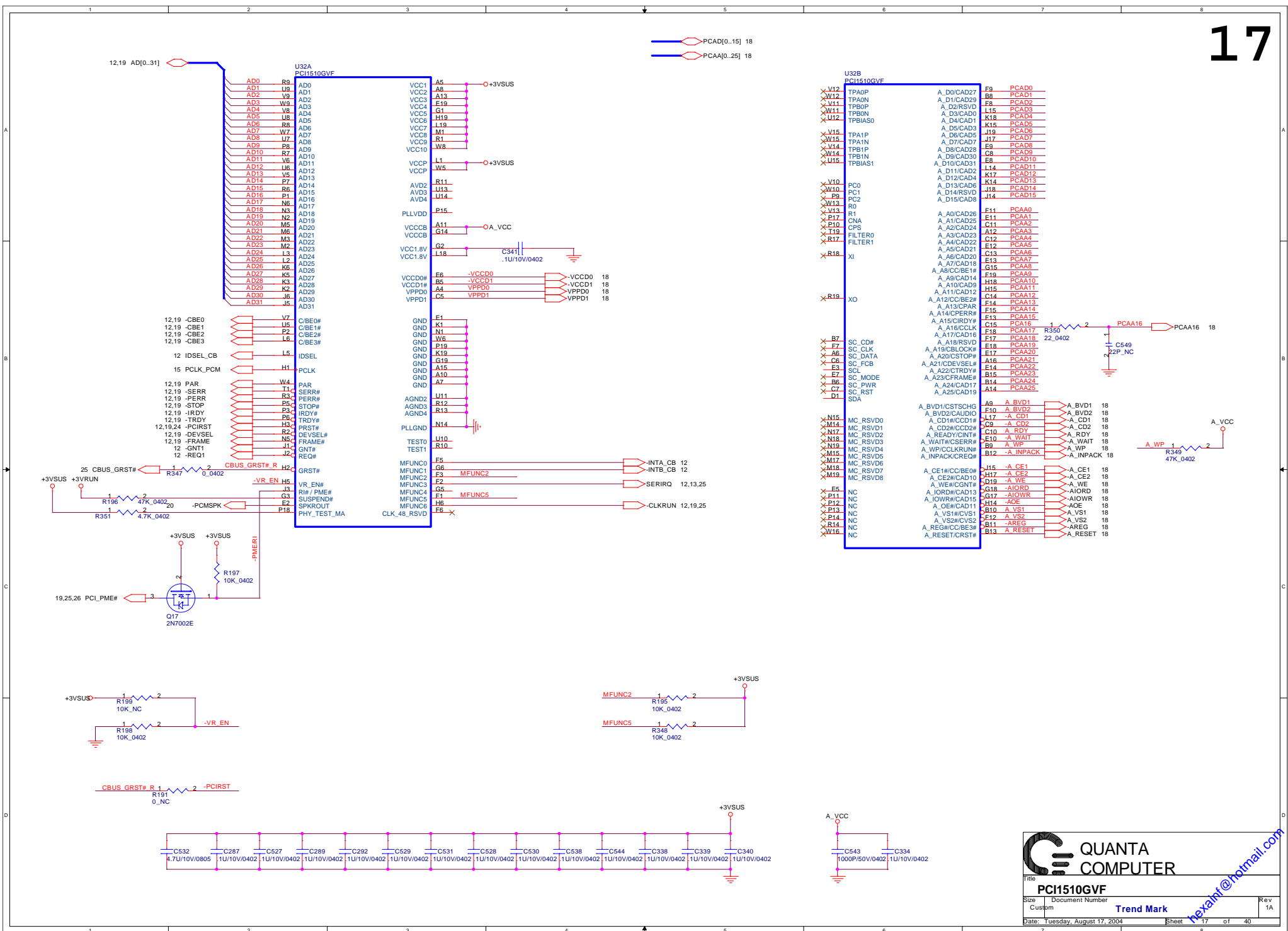

QUANTA COMPUTER

Title: **PCI1510GVF**

Size: Custom | Document Number: Trend Mark | Rev: 1A

Date: Tuesday, August 17, 2004 | Sheet: 17 of 40

hexant@hotmail.com

PCMCIA POWER SWITCH

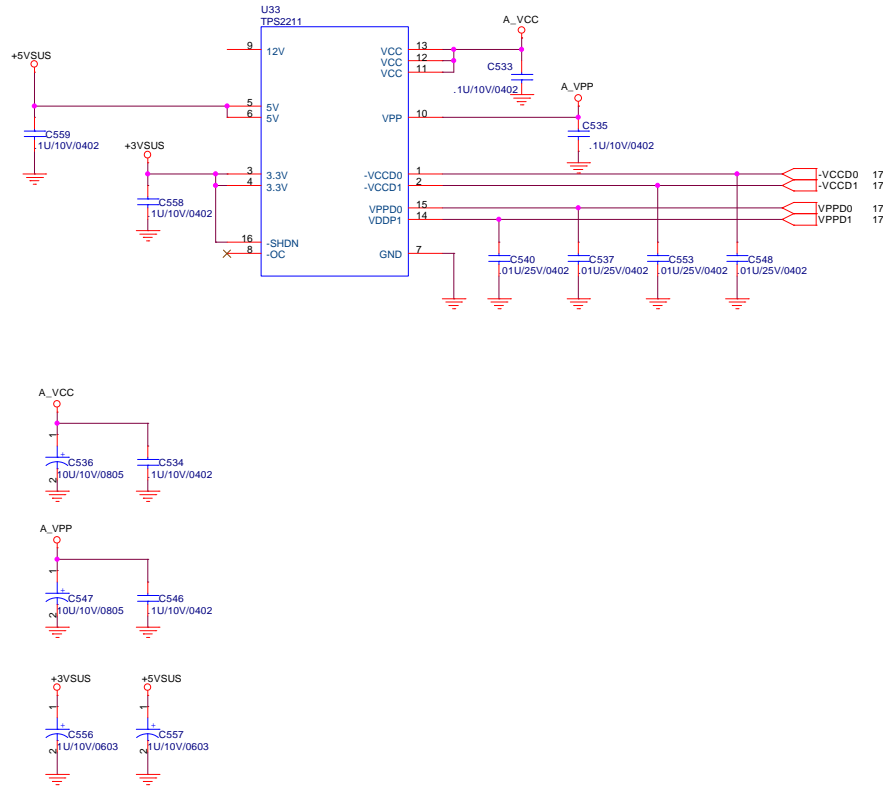

PCMCIA SOCKET

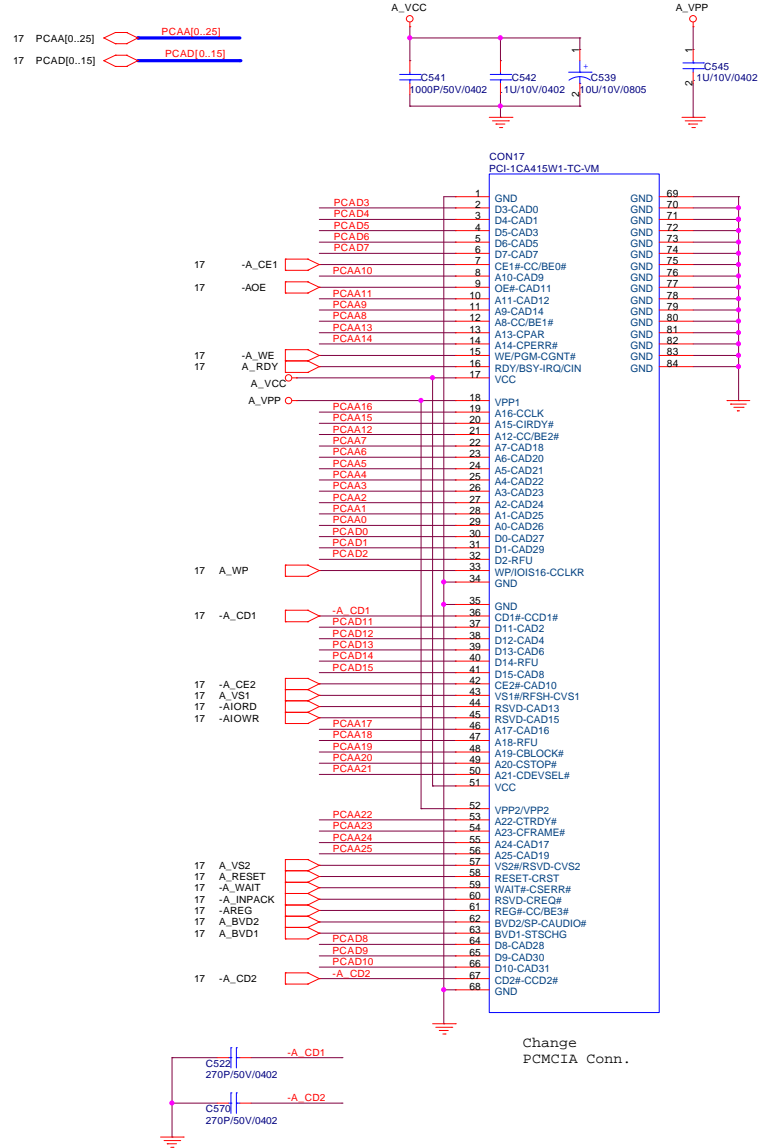

Change PCMCIA Conn.

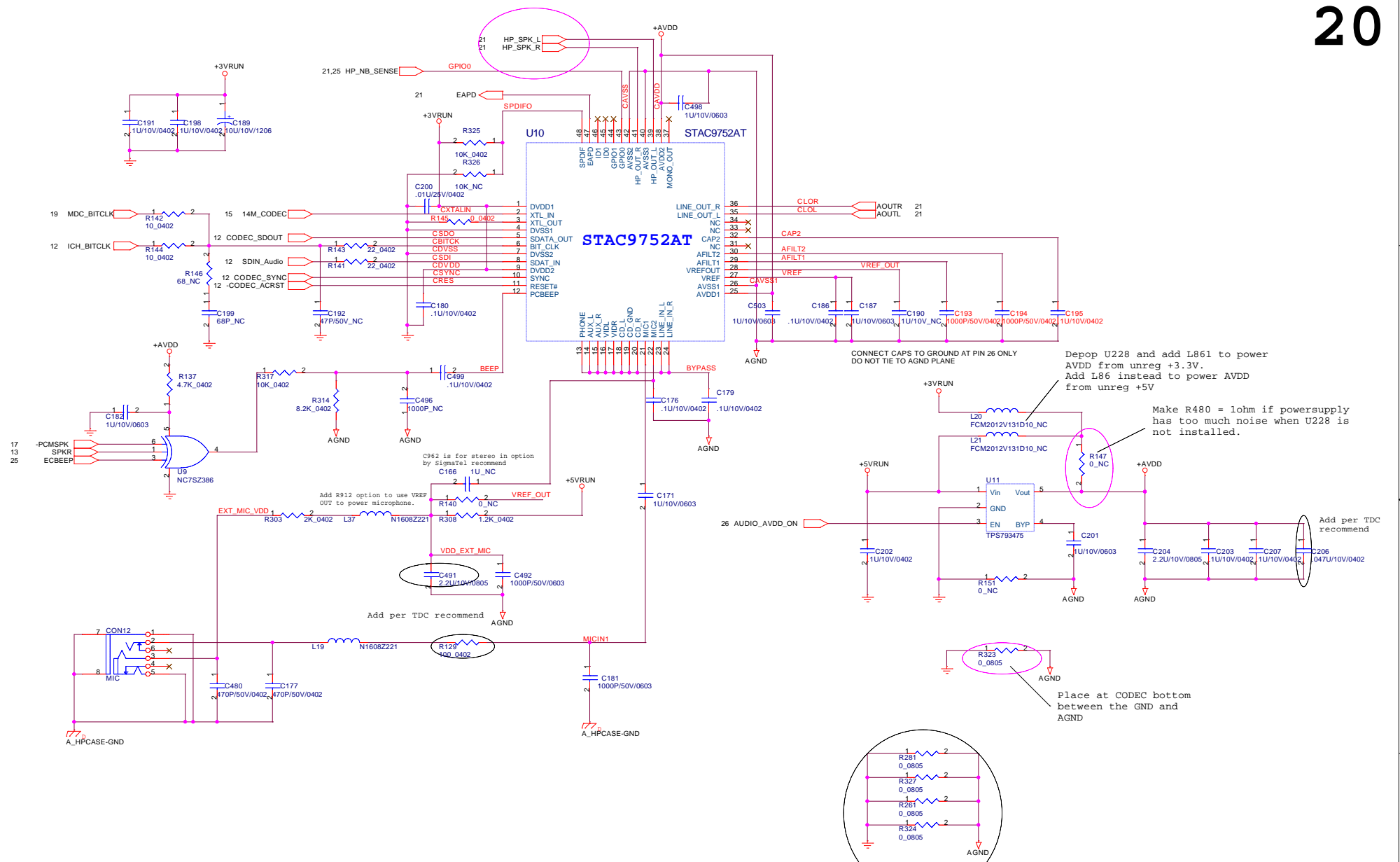

STAC9752A 48/32 DUAL LAYOUT

QUANTA COMPUTER

Audio Codec STAC9753A

File	Document Number	Rev
Size	Custom	1A
Date: Tuesday, August 17, 2004 Sheet 20 of 40		

Trend Mark

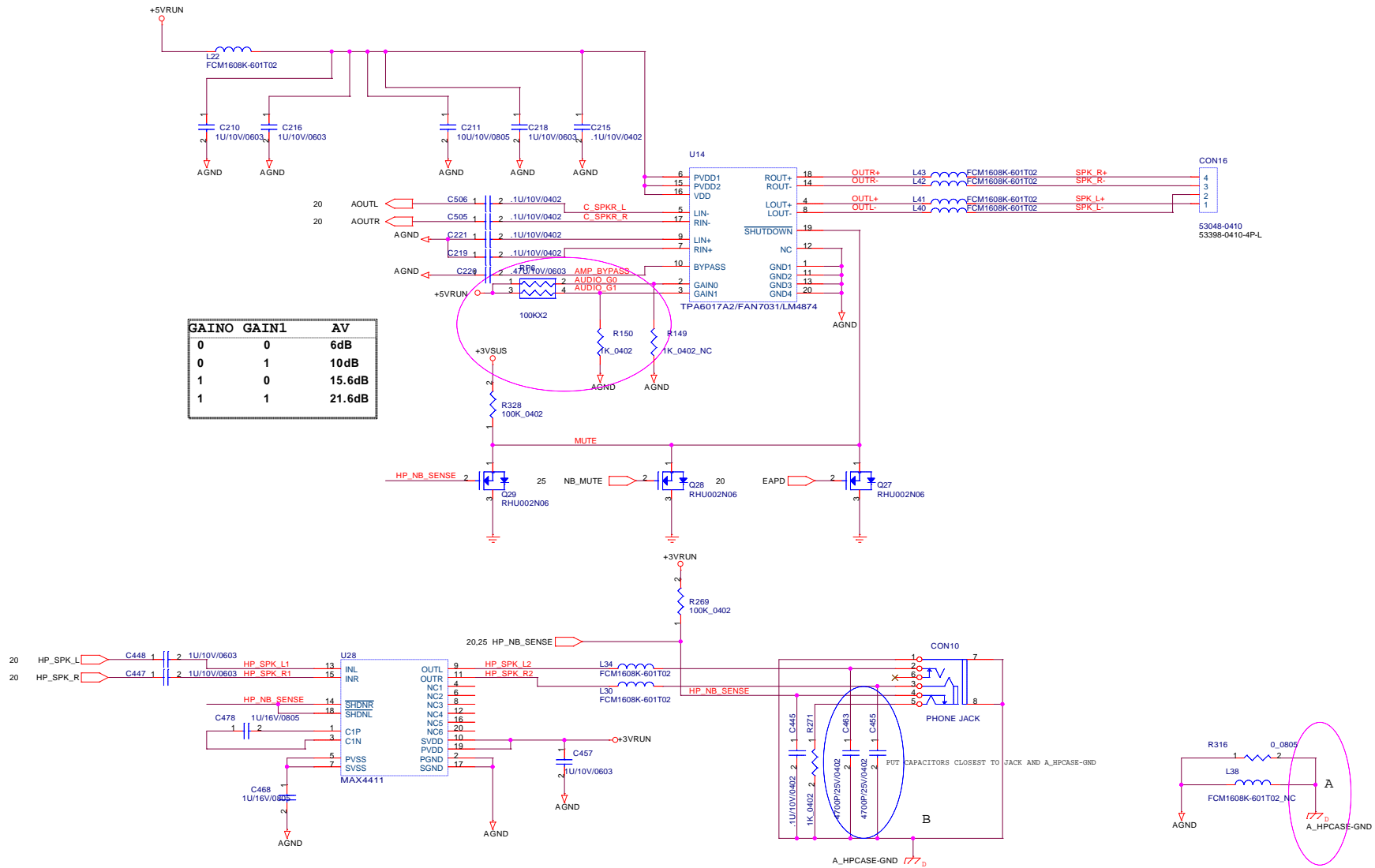

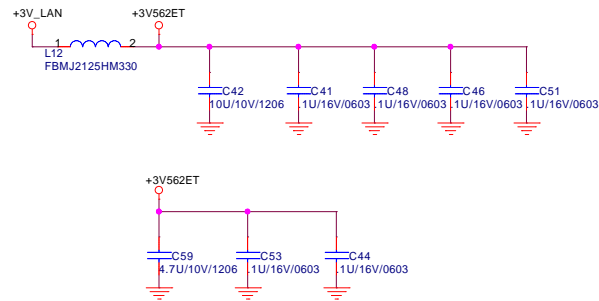
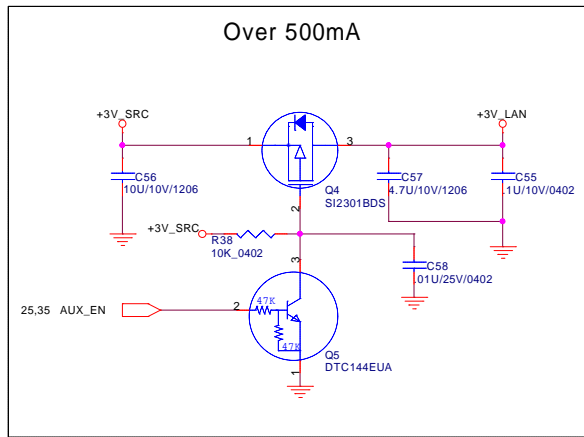
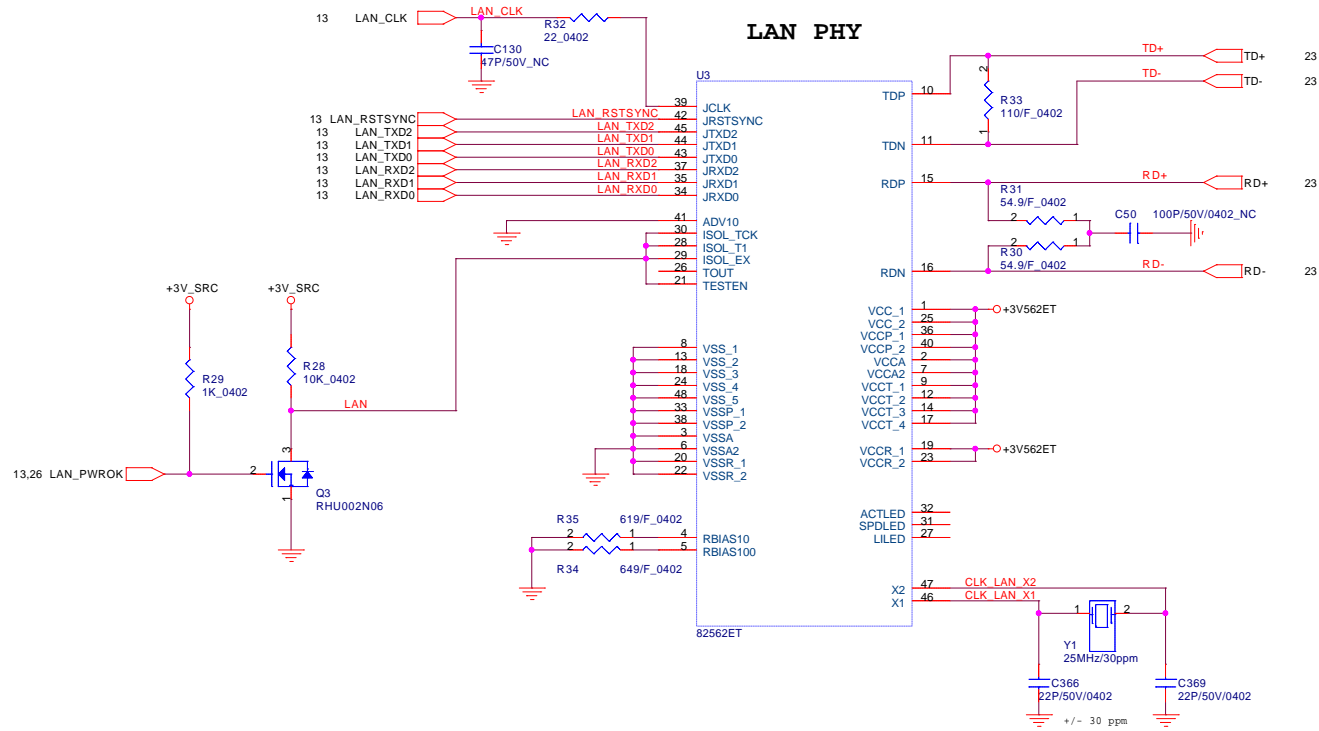

TOUCHPAD BOARD CON

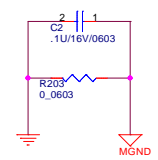
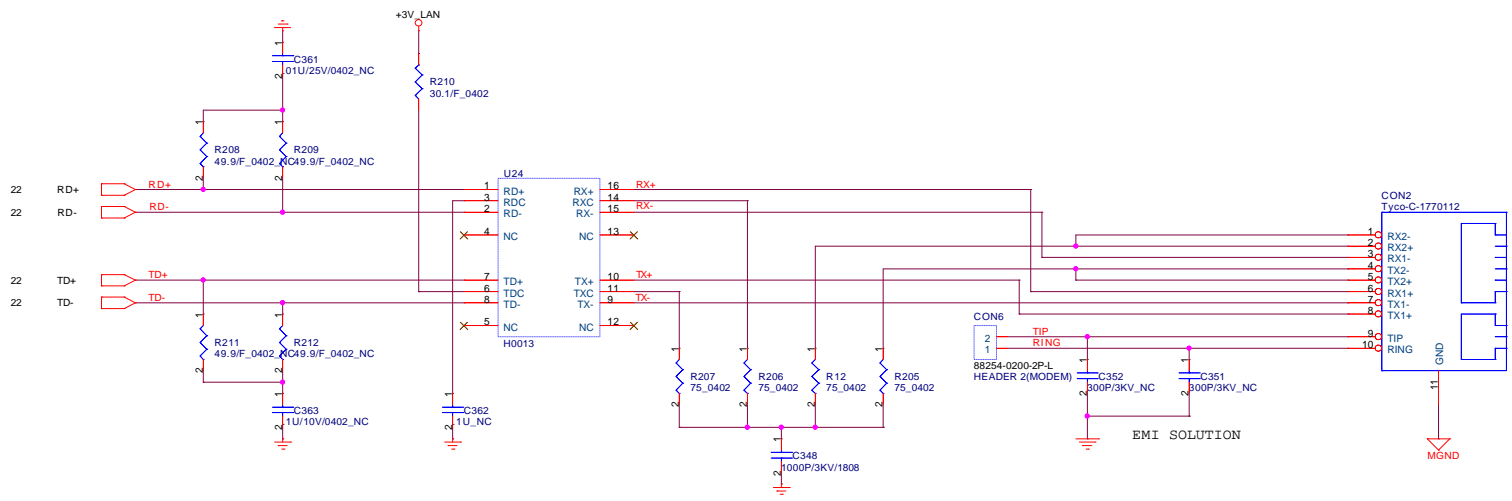
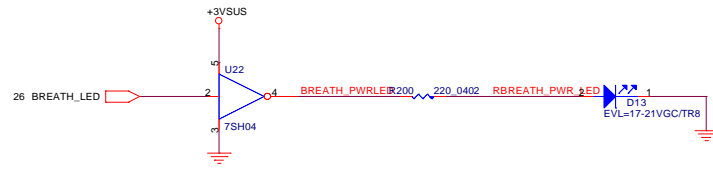
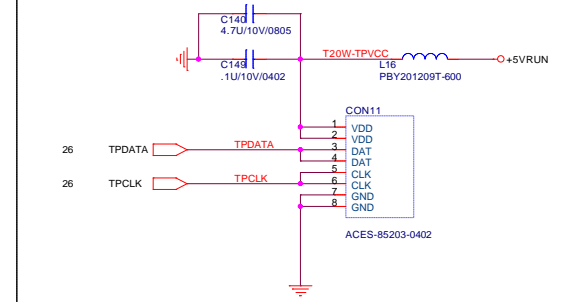
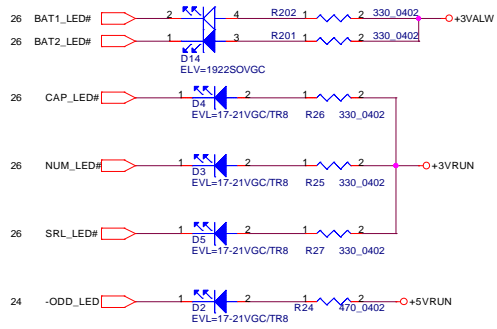

**QUANTA
COMPUTER**

Title: **TP & LAN Connector**

Size: Custom | Document Number: Trend Mark | Rev: 1A

Date: Tuesday, August 17, 2004 | Sheet: 23 of 40

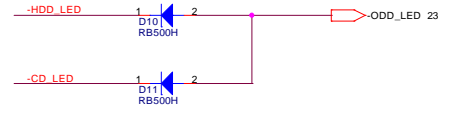
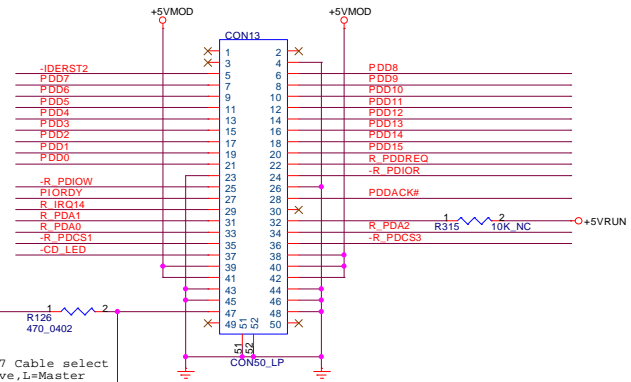
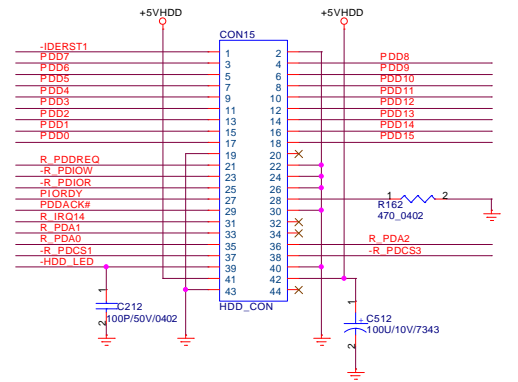
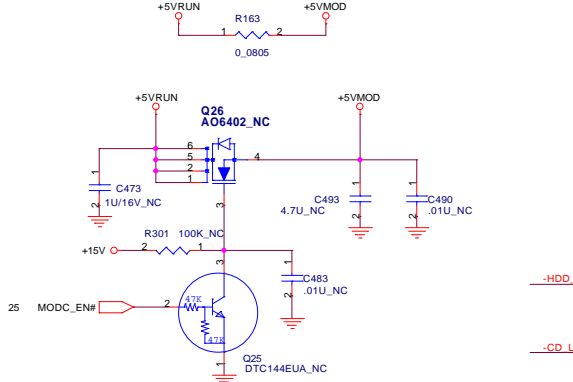
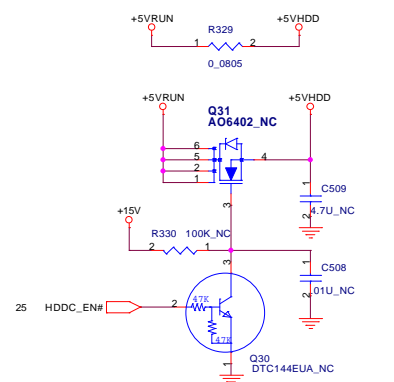
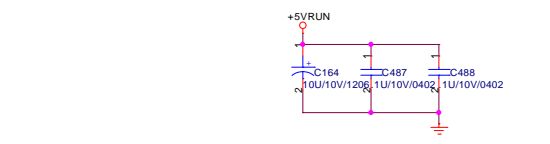
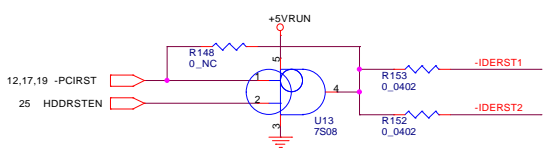
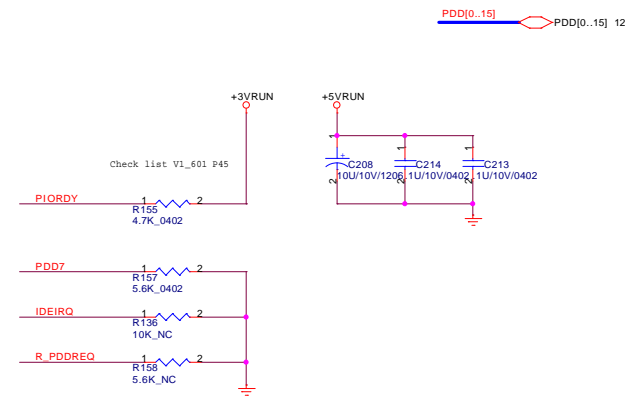
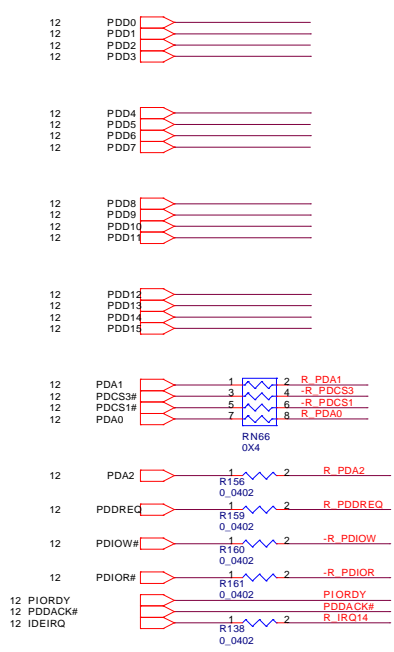

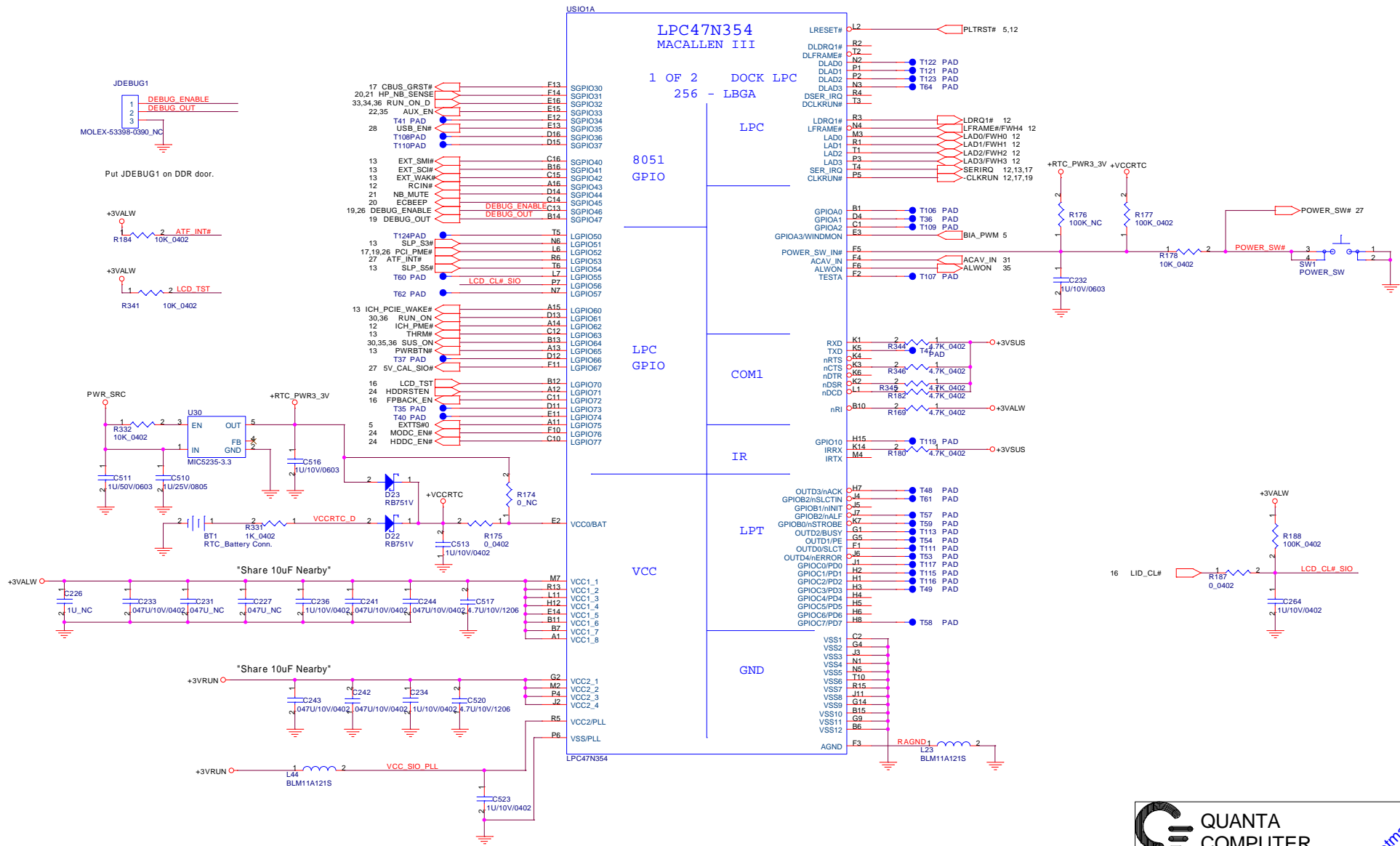

QUANTA COMPUTER

File: Ultra I/O Controller LPC47N254

Size: Document Number VM7 Rev 1A

Date: Tuesday, August 17, 2004 Sheet 25 of 40

hexant@hotmail.com

BID3	BID2	BID1	BID0	Board Revision
0	0	0	0	PROTO1
0	0	1	0	PROTO2
0	0	1	1	PROTO3
0	1	0	0	QT (A00)
0	1	0	1	A01

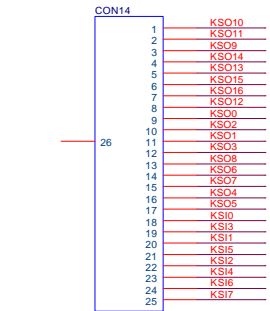
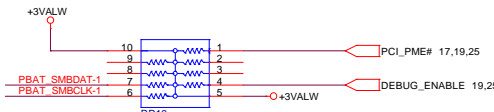
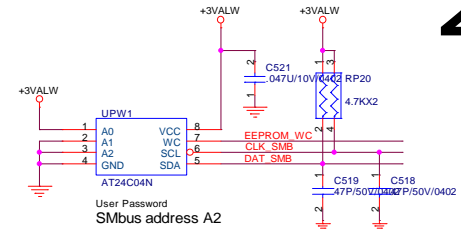
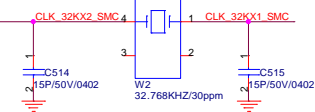
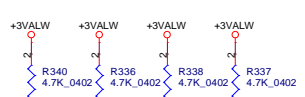
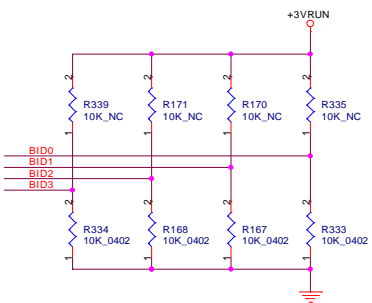

JAE_FK25030W12R1000

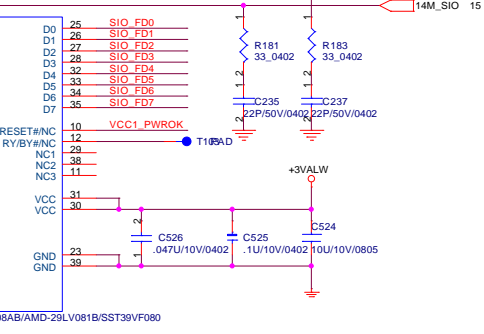
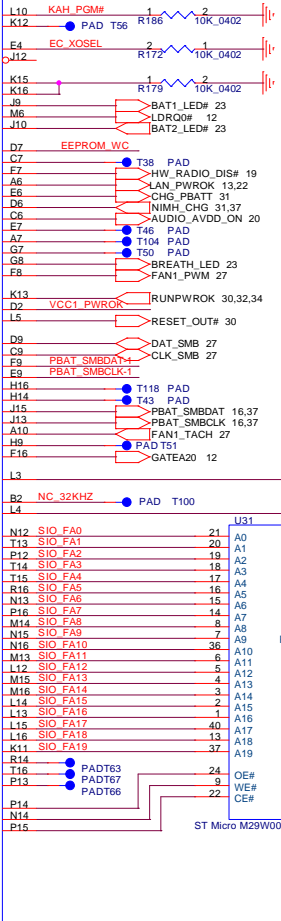
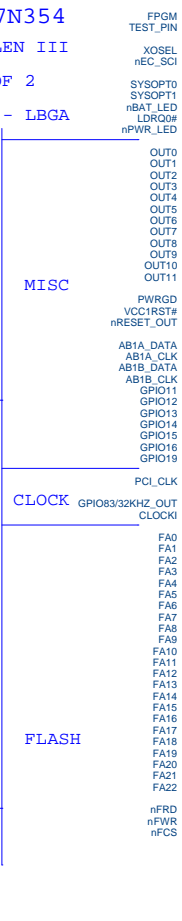
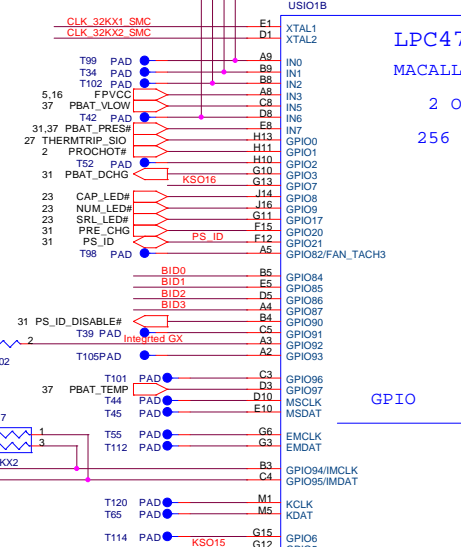

Int. keyboard

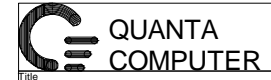
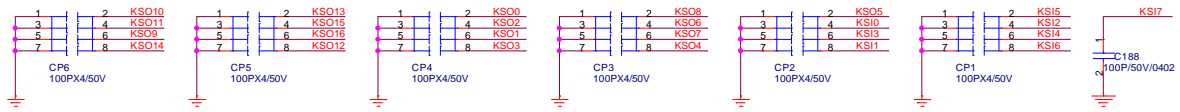

Ultra I/O Controller LPC47N254(GPIO/KB/MISC/FLASH)		
Size	Document Number	Rev
	VM7	1A
Date:	Tuesday, August 17, 2004	Sheet 26 of 40

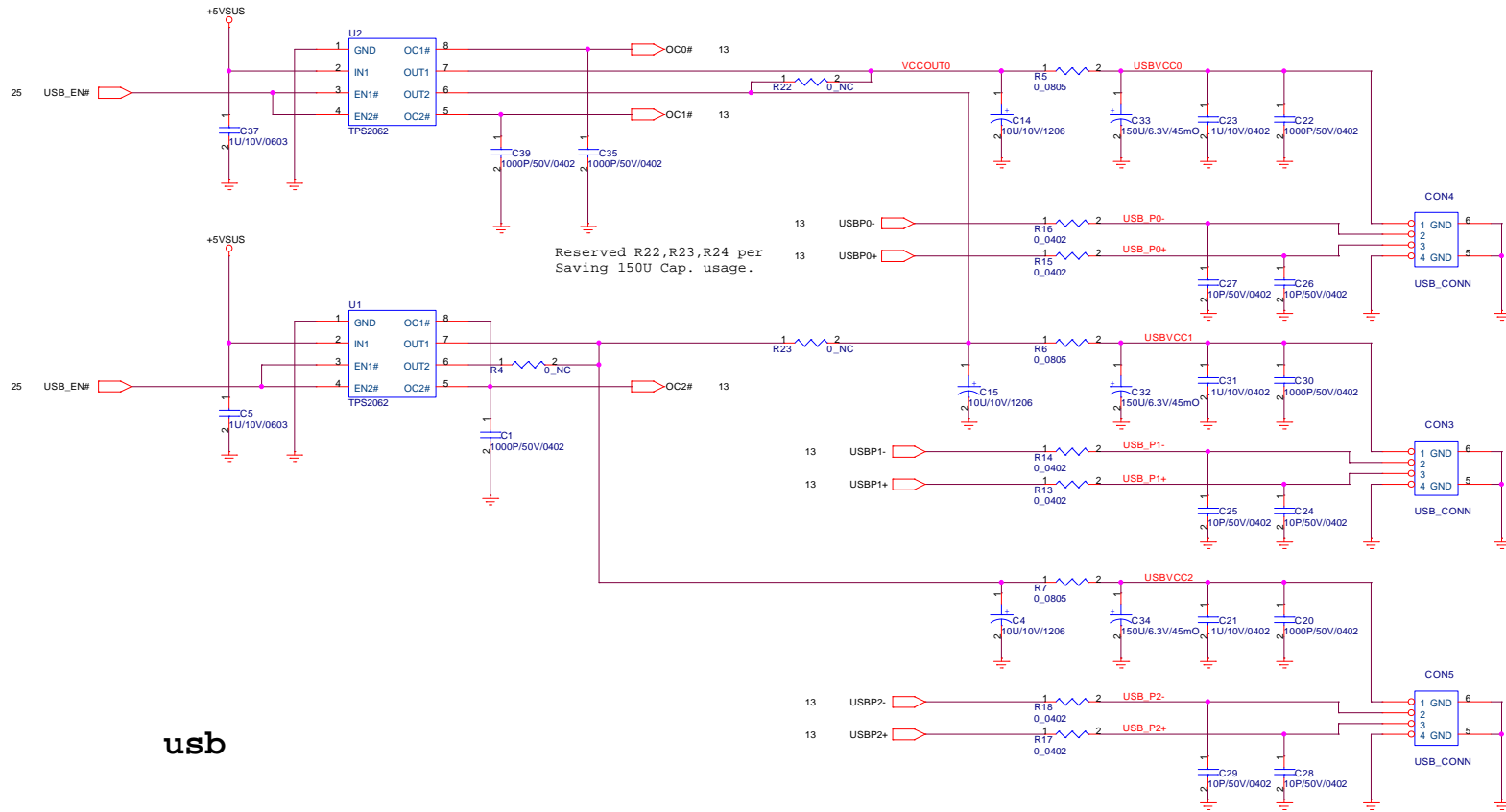

usb

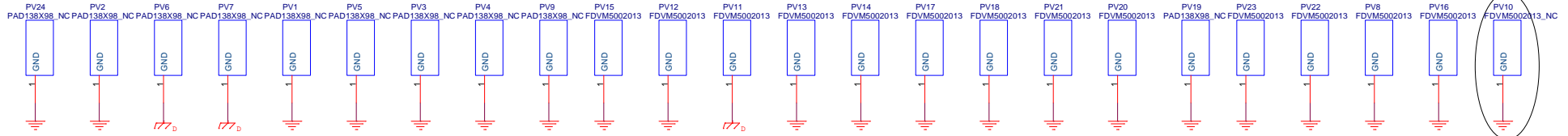

A_HPCASE-GND

EMI added

EMI SOLUTION

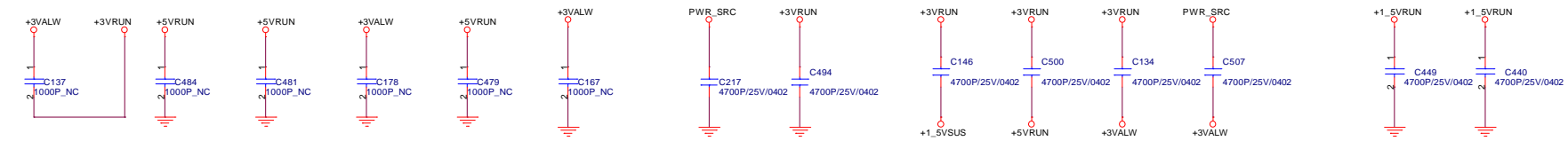
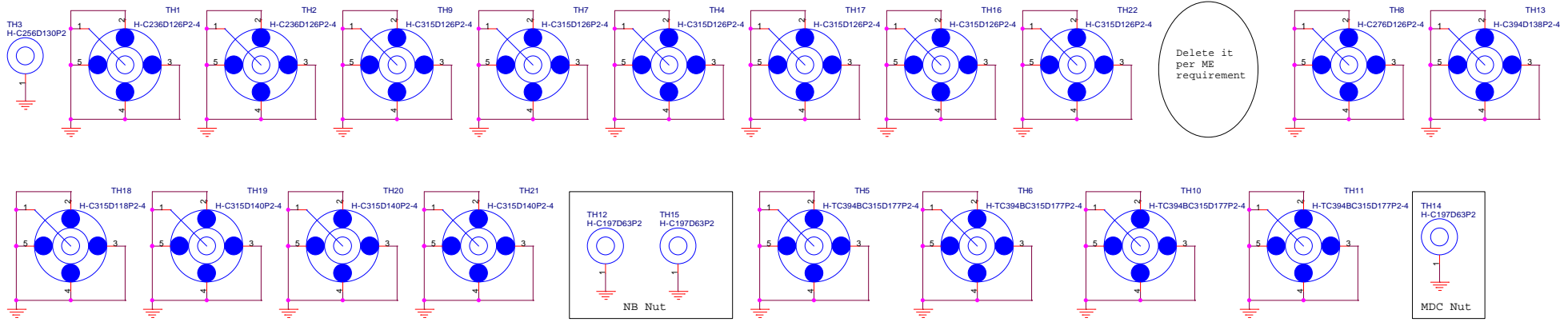

EMI require in 0810

QUANTA COMPUTER

Title: **INT. KEYBOARD**

Size: Custom Document Number: Trend Mark Rev: 1A

Date: Tuesday, August 17, 2004 Sheet: 29 of 40

hexant@hotmail.com

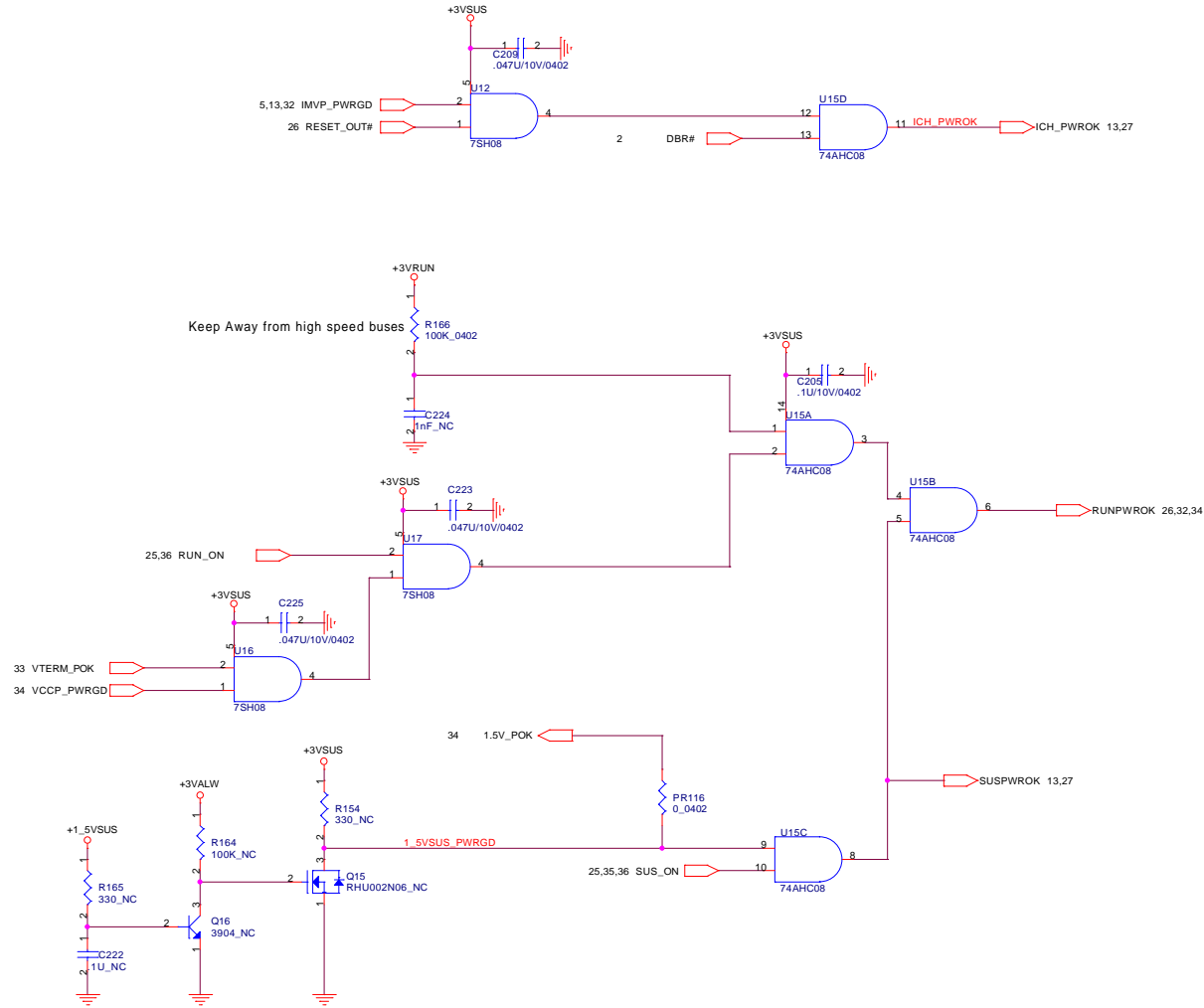

 QUANTA COMPUTER		
Title Power Good Circuit		
Size	Document Number VM7	Rev 1A
Date:	Tuesday, August 17, 2004	Sheet 30 of 40

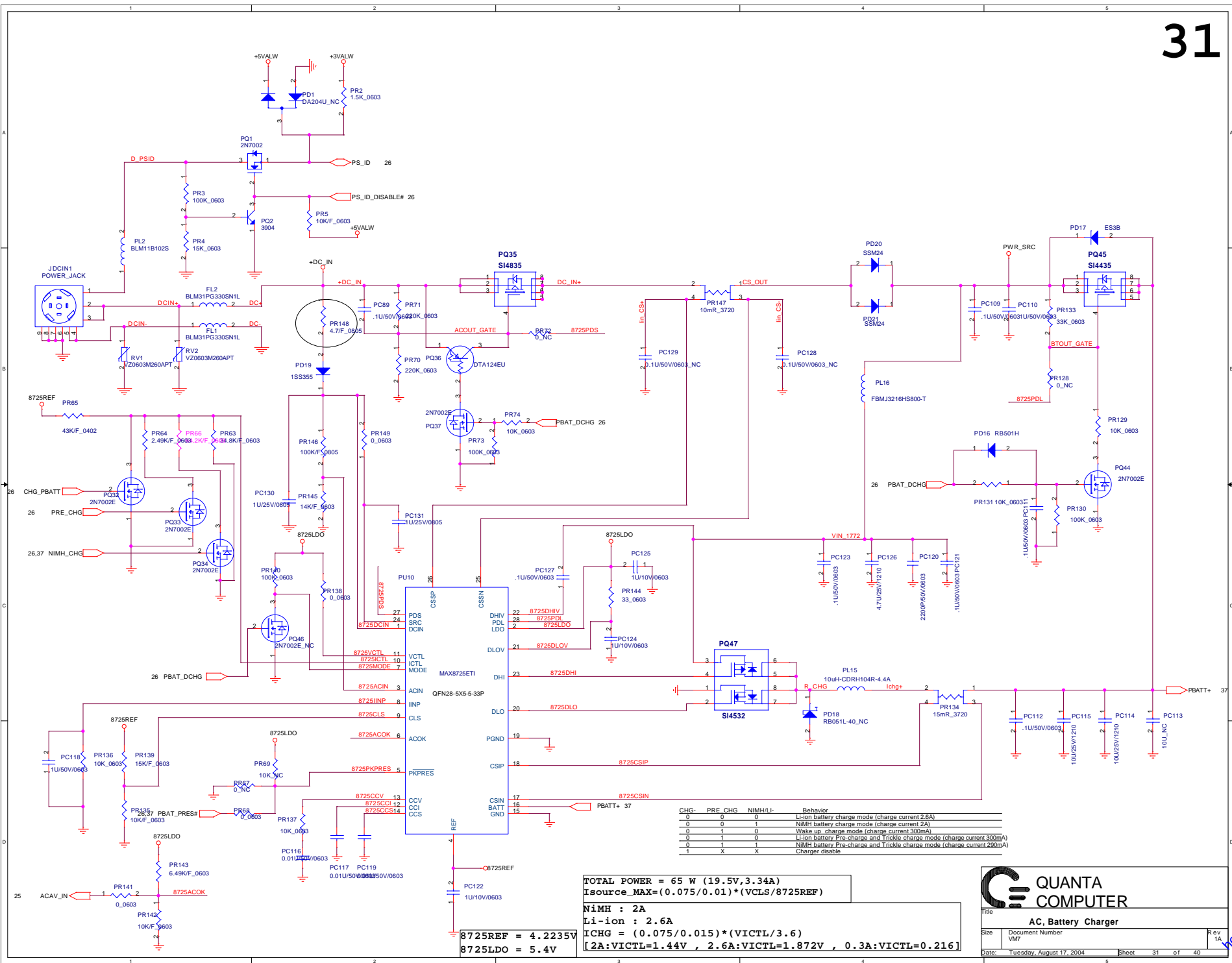

CHG-	PRE_CHG	NIMH/LI-	Behavior
0	0	0	Li-ion battery charge mode (charge current 2.6A)
0	0	1	NIMH battery charge mode (charge current 2A)
0	1	0	Wake up charge mode (charge current 300mA)
0	1	0	Li-ion battery Pre-charge and Trickle charge mode (charge current 300mA)
0	1	1	NIMH battery Pre-charge and Trickle charge mode (charge current 290mA)
1	X	X	Charger disable

TOTAL POWER = 65 W (19.5V, 3.34A)
 $I_{source_MAX} = (0.075/0.01) * (V_{CLS}/8725REF)$

NiMH : 2A
 Li-ion : 2.6A
 $I_{CHG} = (0.075/0.015) * (V_{ICTL}/3.6)$
 [2A:VICTL=1.44V , 2.6A:VICTL=1.872V , 0.3A:VICTL=0.216]

8725REF = 4.2235V
 8725LDO = 5.4V

QUANTA COMPUTER

Title: AC, Battery Charger

Size: Document Number VM7

Date: Tuesday, August 17, 2004 Sheet 31 of 40

R ev 1A

hexant@hotmail.com

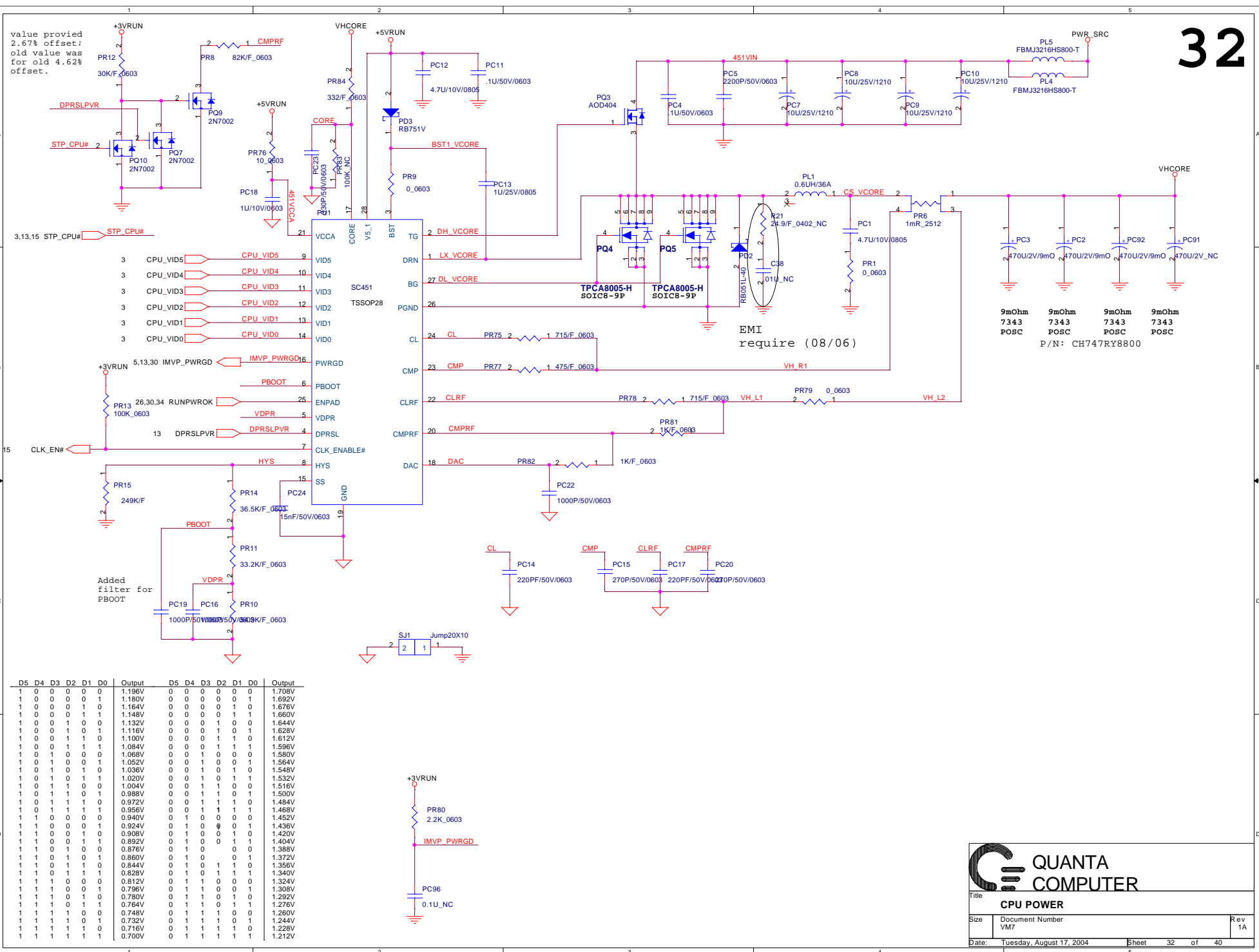

value provided
2.67% offset;
old value was
for old 4.62%
offset.

3,13,15 STP_CPU# STP_CPU#

+3VRUN 5.13,30 IMVP_PWRGD
PBOOT
VDPR
DPRSLVPR
CLK_EN#

Added filter for PBOOT

D5	D4	D3	D2	D1	D0	Output	D5	D4	D3	D2	D1	D0	Output
1	0	0	0	0	0	1.136V	0	0	0	0	0	0	1.708V
1	0	0	0	0	1	1.180V	0	0	0	0	0	1	1.692V
1	0	0	0	1	0	1.164V	0	0	0	0	1	0	1.676V
1	0	0	0	1	1	1.148V	0	0	0	0	1	1	1.660V
1	0	1	0	0	0	1.132V	0	0	0	1	0	0	1.644V
1	0	0	1	0	0	1.116V	0	0	0	1	0	1	1.628V
1	0	0	1	1	0	1.100V	0	0	0	1	1	0	1.612V
1	0	0	1	1	1	1.084V	0	0	0	1	1	1	1.596V
1	0	1	0	0	0	1.068V	0	0	1	0	0	0	1.580V
1	0	1	0	1	0	1.052V	0	0	1	0	1	0	1.564V
1	0	1	0	1	1	1.036V	0	0	1	0	1	0	1.548V
1	0	1	1	0	0	1.020V	0	0	1	0	1	1	1.532V
1	0	1	1	0	1	1.004V	0	0	1	1	0	0	1.516V
1	0	1	1	1	0	0.988V	0	0	1	1	0	1	1.500V
1	0	1	1	1	1	0.972V	0	0	1	1	1	0	1.484V
1	0	1	1	1	1	0.956V	0	0	1	1	1	1	1.468V
1	1	0	0	0	0	0.940V	0	1	0	0	0	0	1.452V
1	1	0	0	0	1	0.924V	0	1	0	0	1	0	1.436V
1	1	0	0	1	0	0.908V	0	1	0	1	0	0	1.420V
1	1	0	0	1	1	0.892V	0	1	0	1	1	0	1.404V
1	1	0	1	0	0	0.876V	0	1	0	0	0	0	1.388V
1	1	0	1	0	1	0.860V	0	1	0	0	1	0	1.372V
1	1	0	1	1	0	0.844V	0	1	0	1	0	1	1.356V
1	1	0	1	1	1	0.828V	0	1	0	1	1	1	1.340V
1	1	1	0	0	0	0.812V	0	1	1	0	0	0	1.324V
1	1	1	0	0	1	0.796V	0	1	1	0	0	1	1.308V
1	1	1	0	1	0	0.780V	0	1	1	0	1	0	1.292V
1	1	1	0	1	1	0.764V	0	1	1	0	1	1	1.276V
1	1	1	1	0	0	0.748V	0	1	1	1	0	0	1.260V
1	1	1	1	0	1	0.732V	0	1	1	1	0	1	1.244V
1	1	1	1	1	0	0.716V	0	1	1	1	1	0	1.228V
1	1	1	1	1	1	0.700V	0	1	1	1	1	1	1.212V

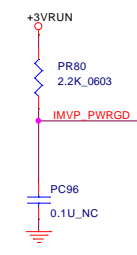

9mOhm 9mOhm 9mOhm 9mOhm
7343 7343 7343 7343
POSC POSC POSC POSC
P/N: CH747RY8800

**QUANTA
COMPUTER**

Title: **CPU POWER**

Size: Document Number VM7	Rev: 1A
Date: Tuesday, August 17, 2004	
Sheet 32 of 40	

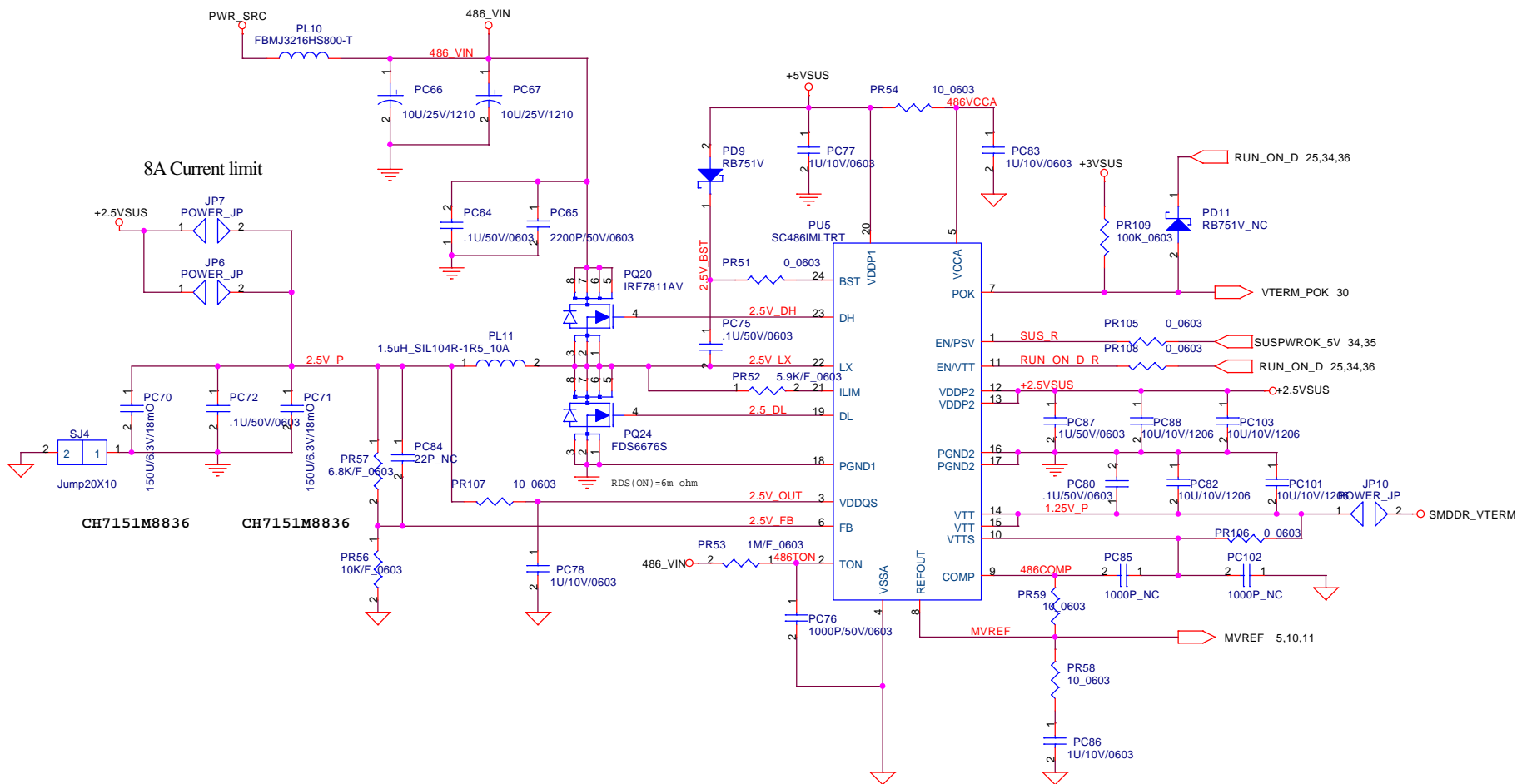

Title		2.5VSUS,SMDDR_VTER	
Size	Document Number	Rev	1A
VM7			
Date:	Tuesday, August 17, 2004	Sheet	33 of 40

hexaint@hotmail.com

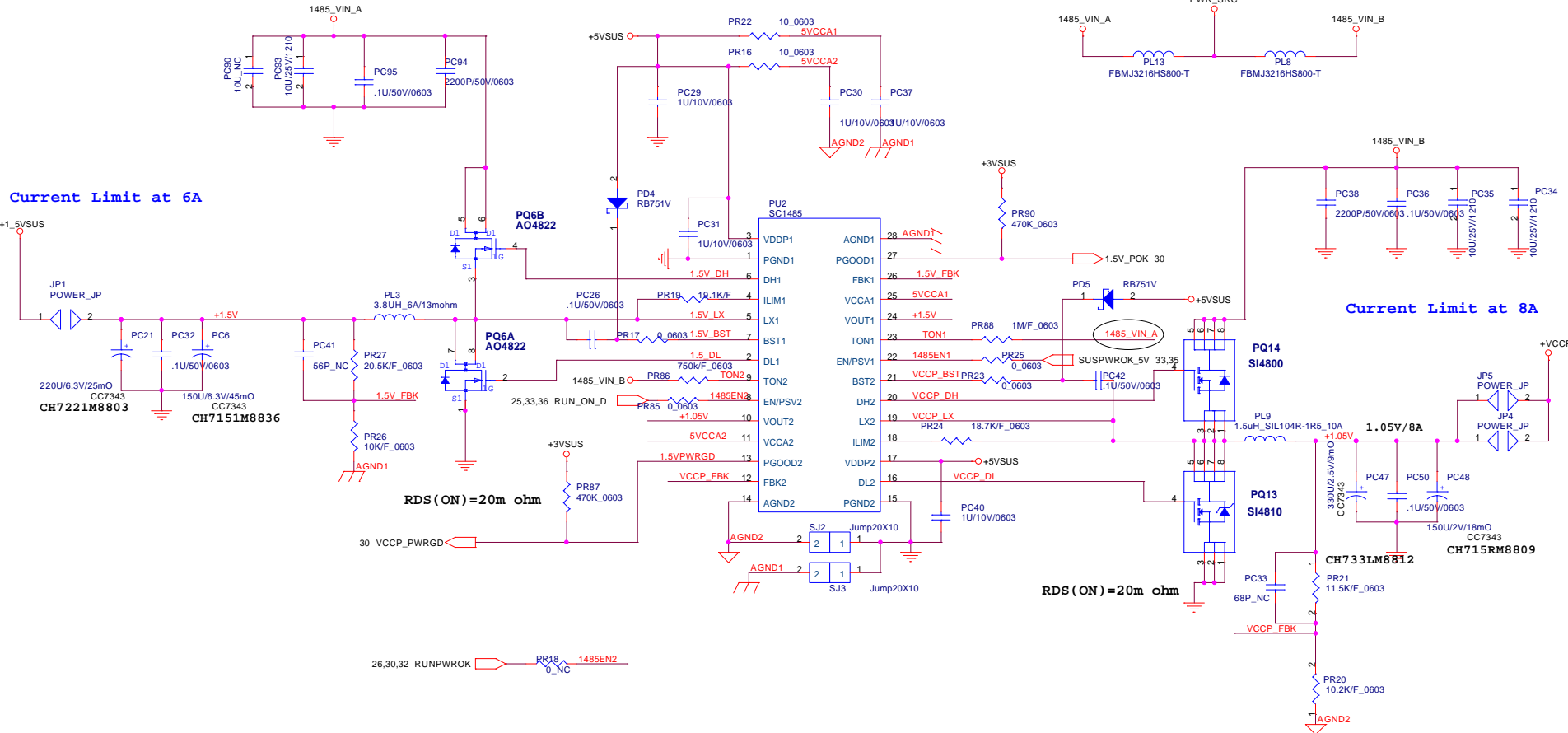

X6S

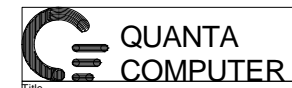

Title		
1.5VSUS, VCCP(1.05V)		
Size	Document Number	Rev
VM7		1A
Date:	Tuesday, August 17, 2004	Sheet 34 of 40

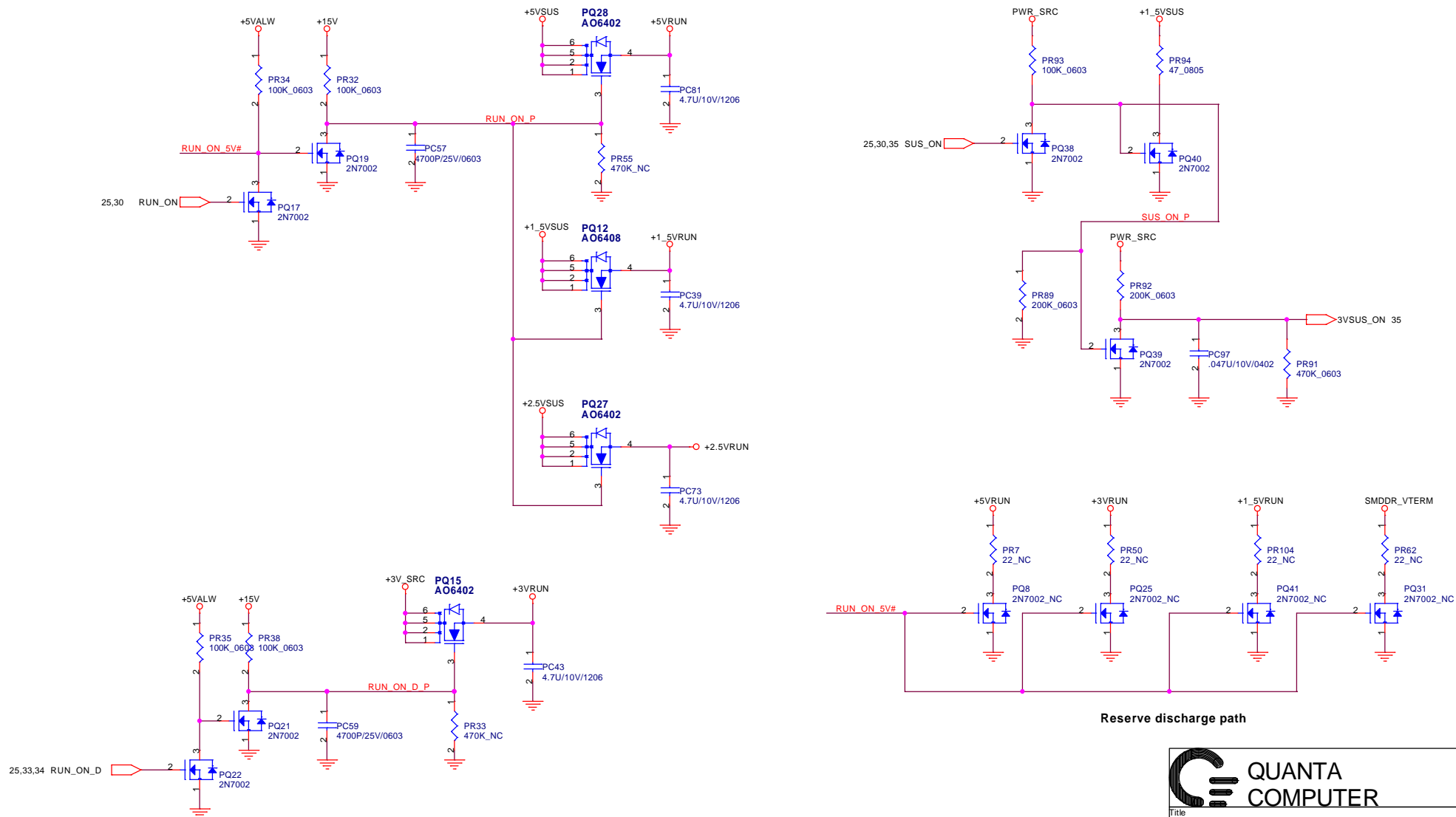

Reserve discharge path

 QUANTA COMPUTER		
Title		
RUN POWER SW		
Size	Document Number	Rev
VM7		1A
Date:	Tuesday, August 17, 2004	Sheet 36 of 40

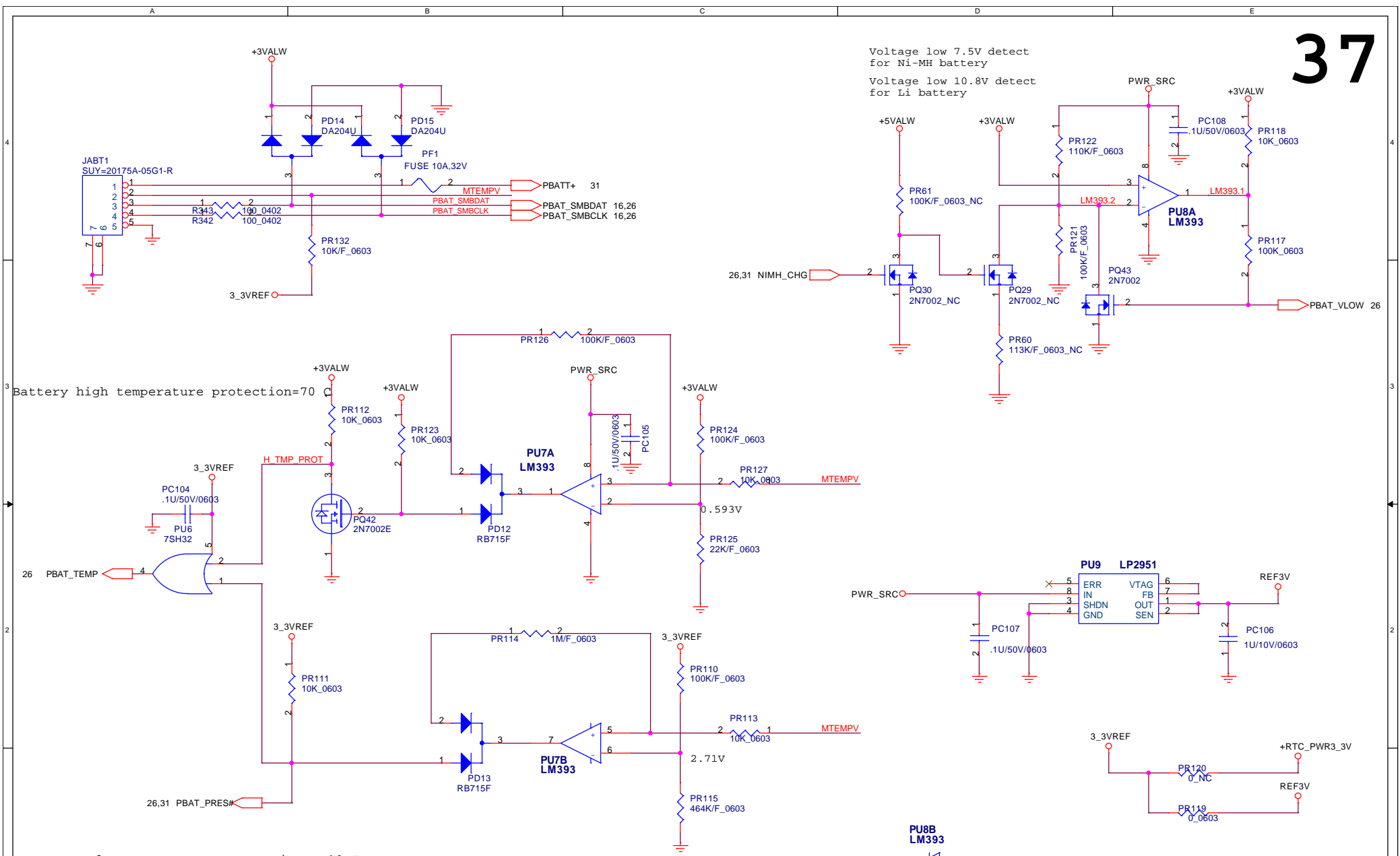

Battery high temperature protection=70

Battery low temperature protection= -10 C

When BATTERY not insert MTEMPV 3.3V
 When BATTERY -10 C => NTC=46.6K MTEMPV 2.71V
 When BATTERY 0C => NTC=28.6K MTEMPV=2.45V
 When BATTERY 25 C => NTC=10K MTEMPV=1.65V
 When BATTERY 60 C => NTC=3K MTEMPV=0.76V
 When BATTERY 70 C => NTC=2.19K MTEMPV=0.593V

	PWR_SRC								
	+3VAL	+3VALL	BAT 25C	BAT-20C	BAT 80C	BAT NOT IN	PBAT PRES#	PBAT TEMP	PBAT VLOW
When Battery Only	V	-	X	X	X	-	Lo	Not Active	Not Active
When AC and Battery in	V	V	V	V	-	-	Lo	Lo	Active
	V	V	V	V	-	-	Hi	Hi	Active
When AC In , Battery Not In	V	V	X	X	X	V	Lo	Hi	Active
	V	V	X	X	X	-	Hi	X	X

Voltage low 7.5V detect for Ni-MH battery
 Voltage low 10.8V detect for Li battery

QUANTA COMPUTER

Title: **Battery connector & Protection**

Size: VM7 Document Number: Rev 1A

Date: Tuesday, August 17, 2004 Sheet 37 of 40