

755SA1 BLOCK DIAGRAM

www.sp860.com QQ: 453100829

A-PDF Watermark DEMO: Purchase from www.A-PDF.com to remove the watermark

755SA1 P/N:

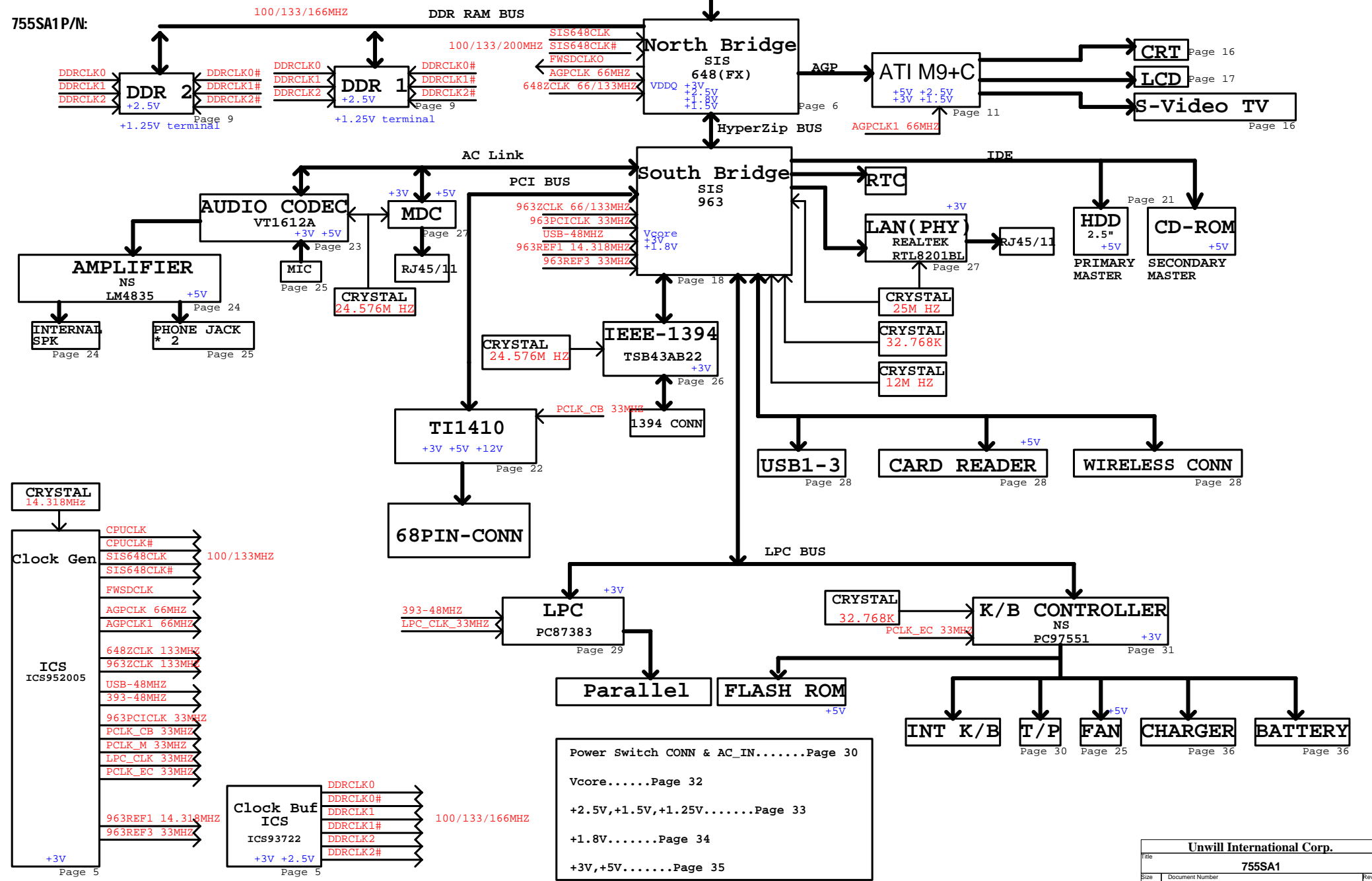

Unwill International Corp.			
755SA1			
Size	Document Number	SYSTEM BLOCK DIAGRAM	Rev A
Date:	Monday, December 08, 2003	Sheet 1	of 38

RA to RB

- Modify 1 : Change R371 to 3.48k_1 for +1.8V
- Modify 2 : Remove C392 for +1.8V Power ON Sequence
- Modify 3 : Modify for Schematic Error
- Modify 4 : Change R414 to 0 ohm for +3v_ON Voltage Level
- Modify 5 : Modify for Schematic Error
- Modify 6 : Add 2200P for Switching Power Quality
- Modify 7 : Change PR12 to 0 ohm for EC Voltage Level
- Modify 8 : Modify R524 Connect to VCC_AMP for VR1
- Modify 9 : Modify Schematic for S3 Power Sequence
- Modify 10 : Add C660 for 648 Request
- Modify 11 : Reserve C655,C656,C657,C658,C659,C661,C662 for 648 Request
- Modify 12 : Add R830 470 ohm for HVREF
- Modify 13 : Change PR2,PR4,PR6,PR8 for Total Power Accuracy
- Modify 14 : Add R831 for CMOS Discharge Safety
- Modify 15 : Remove 0 ohm for Software Bug
- Modify 16 : Change Wireless CONN Pin Define for Design Issue
- Modify 17 : Remove R for VRAM On Board
- Modify 18 : Add 0 ohm for CPU Power Current Return Path
- Modify 19 : Add Schematic and modify R557,R556 value for SPK volume
- Modify 20 : Add Schematic for EC to select CPU frequency
- Modify 21 : Add R839,R840 and DDR memory capacitance for DDR stability
- Modify 22 : Add bypass capacitance for difference power plane
- Modify 23 : Add capacitance for sis648 system stability
- Modify 24 : Add capacitance for VGA system stability
- Modify 25 : Add MEM_ID select for VRAM on Board
- Modify 26 : Add for EC SMP fuction
- Modify 27 : Improve Audio Signal Quality
- Modify 28 : Add schematic for audio
- Modify 29 : Modify for EMI

Unwill International Corp.			
Title		755SA1	
Size	Document Number	Rev	A
	2410	REVISION HISTORY	
Date:	Monday, December 08, 2003	Sheet	2 of 38

CPU_CORE

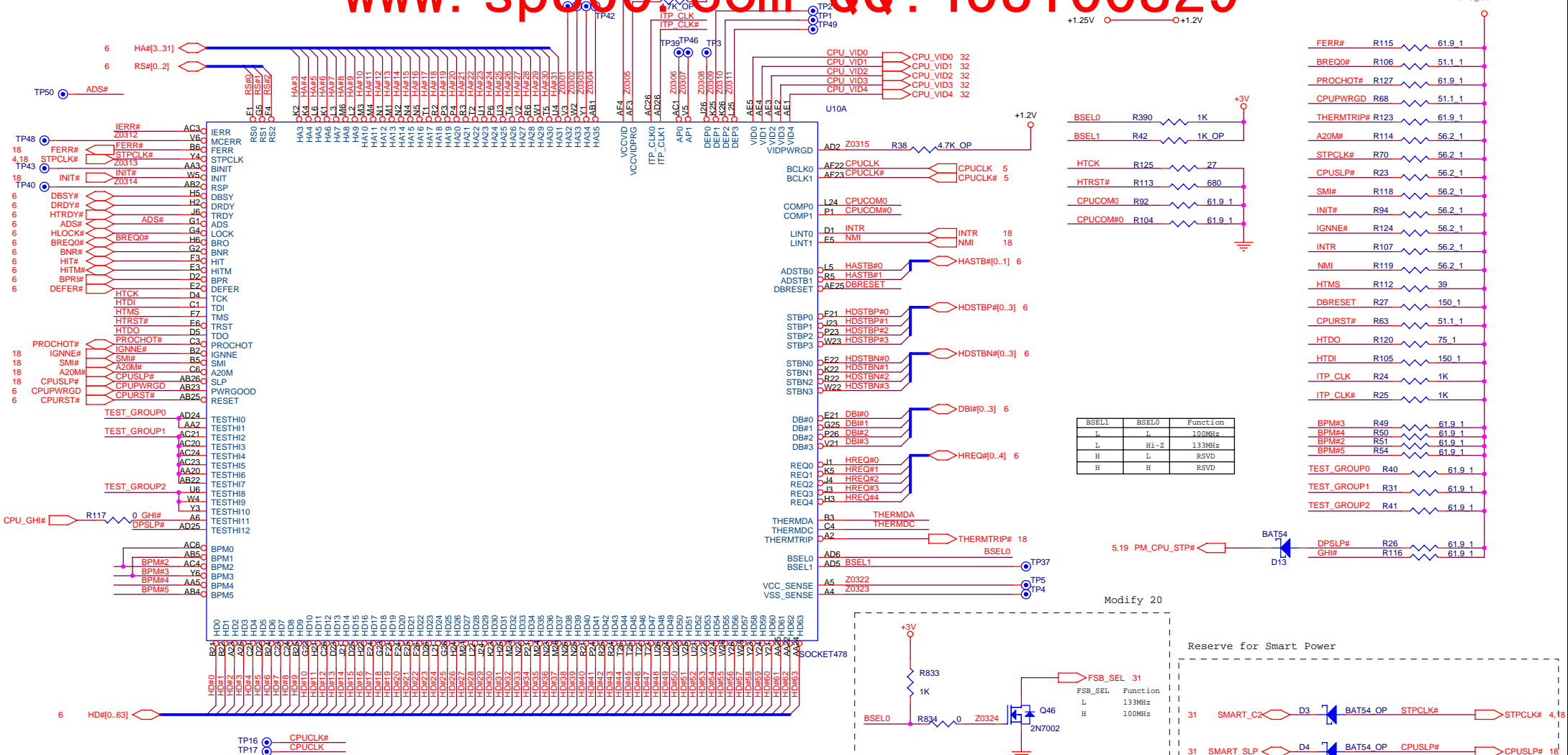

CPU HOT THROTTLING/SHUT DOWN PROTECT CIRCUIT

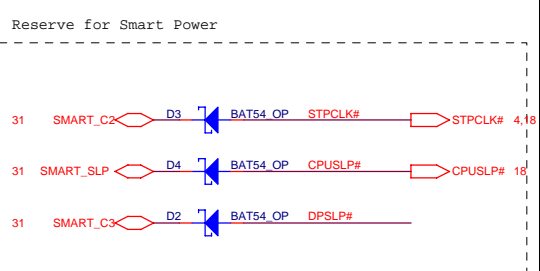
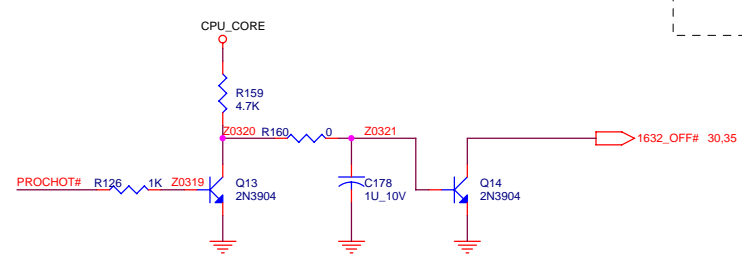
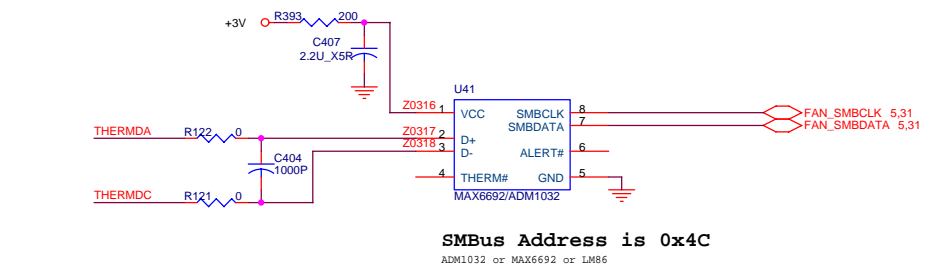

Unwill International Corp.			
755SA1			
Size	Document Number	Rev	
2410	P4 CPU1(Host)	A	
Date:	Monday, December 08, 2003	Sheet	3 of 38

CPU_CORE

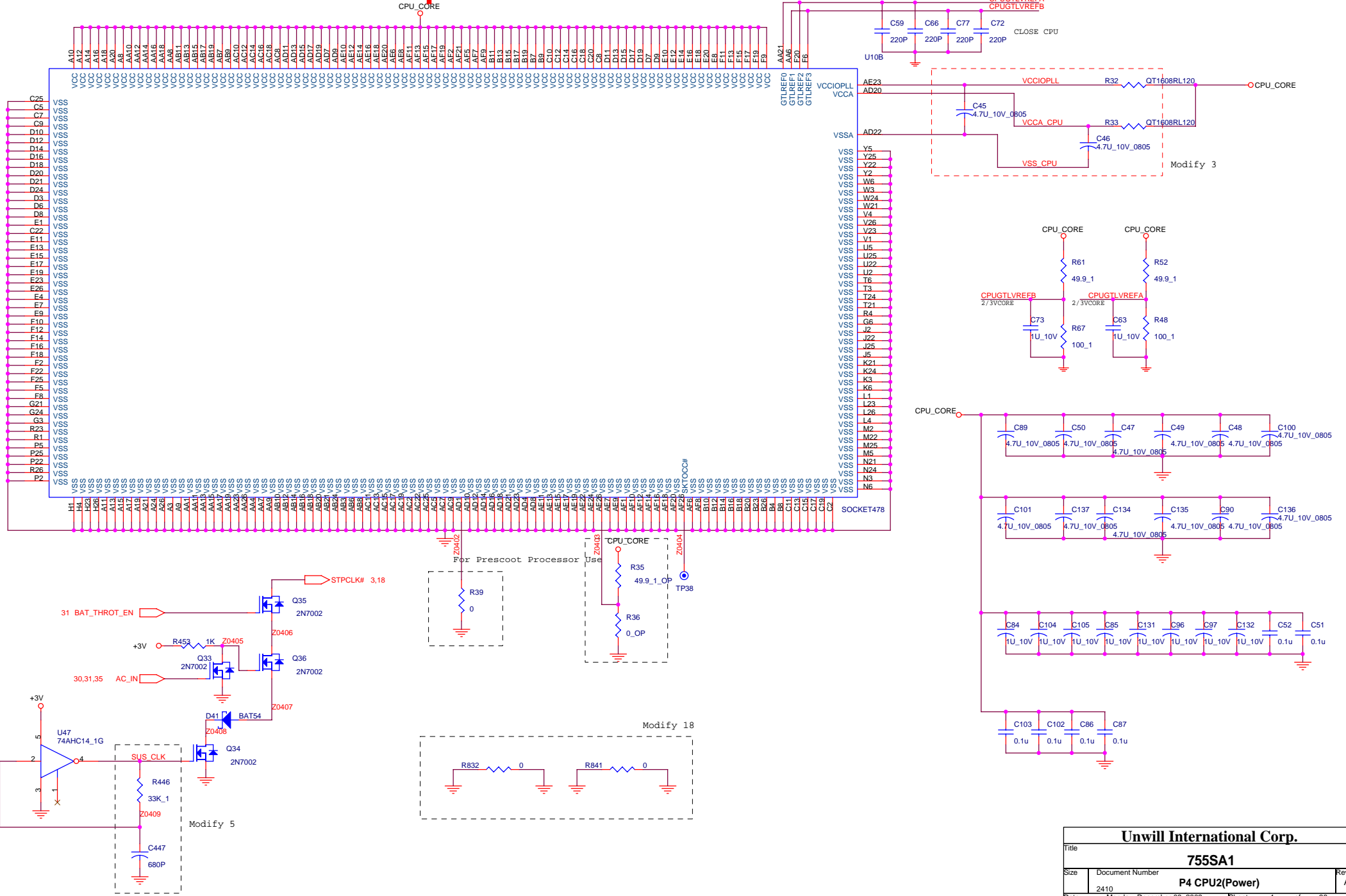

Unwill International Corp.		
Title	755SA1	
Size	Document Number	Rev
2410	P4 CPU2(Power)	A
Date:	Monday, December 08, 2003	Sheet 4 of 38

Main Clock Generator

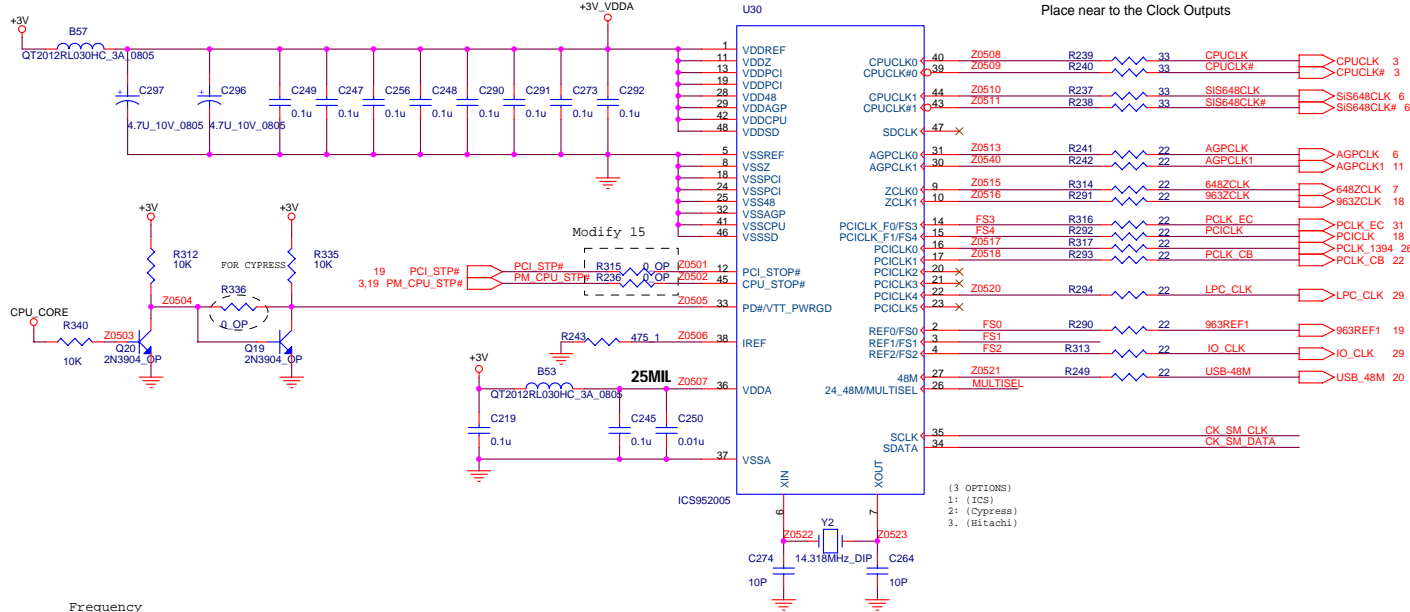

Place near to the Clock Outputs

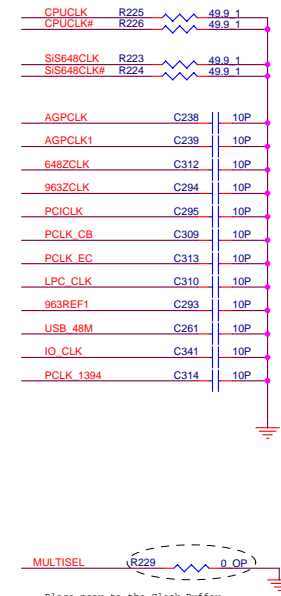

Place near to the Clock Buffer

Frequency Selection

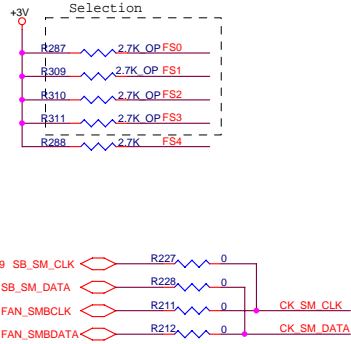

Clock Buffer (DDR)

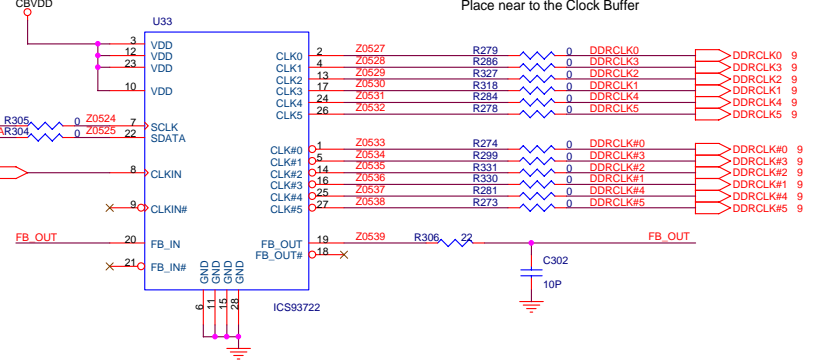

Place near to the Clock Buffer

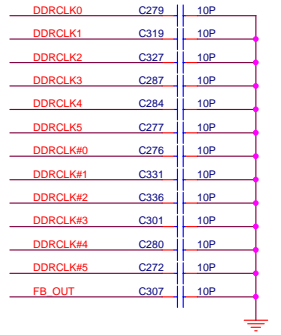

Place near to the Clock Buffer

FUNCTIONALITY

BIT6	BIT5	FS4	FS3	FS2	FS1	FS0	CPU	DDR_RAM	AGP	PCI	ZCLK
0	1	1	0	0	0	0	100	100	66.67	33.3	133.3
0	1	1	0	1	0	1	133.3	133.3	66.67	33.3	133.3
0	1	1	0	1	1	1	133.3	166.67	66.67	33.3	133
0	1	1	0	0	0	1	100	133	66.67	33.3	133.3
0	1	1	0	0	1	1	100	167	66.67	33.3	133

Unwill International Corp.

File		
755SA1		
Size	Document Number	Rev
	CLOCK GEN ICS952005	A
Date:	Monday, December 08, 2003	Sheet 5 of 38

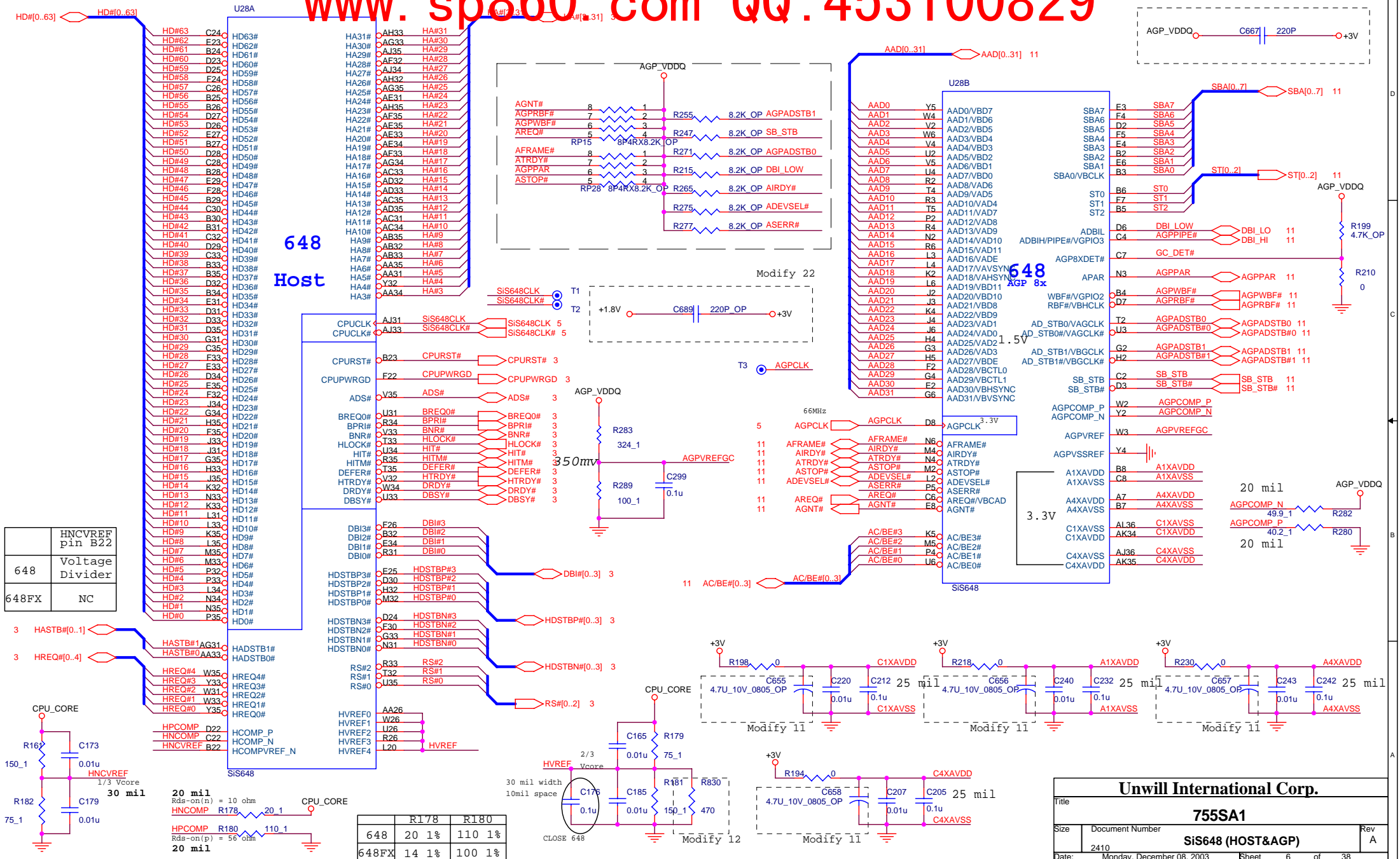

648	HNCVREF	pin B22
648FX	Voltage Divider	NC

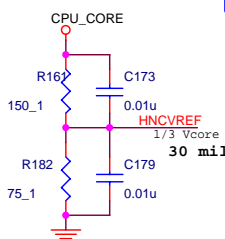

20 mil
Rds-on(n) = 10 ohm
HNCOMP R178 20_1 CPU_CORE

HPCOMP R180 110_1
Rds-on(p) = 56 ohm
20 mil

	R178	R180
648	20 1%	110 1%
648FX	14 1%	100 1%

Unwill International Corp.		
755SA1		
SIS648 (HOST&AGP)		Rev A
Size	Document Number	
2410		
Date:	Monday, December 08, 2003	Sheet 6 of 38

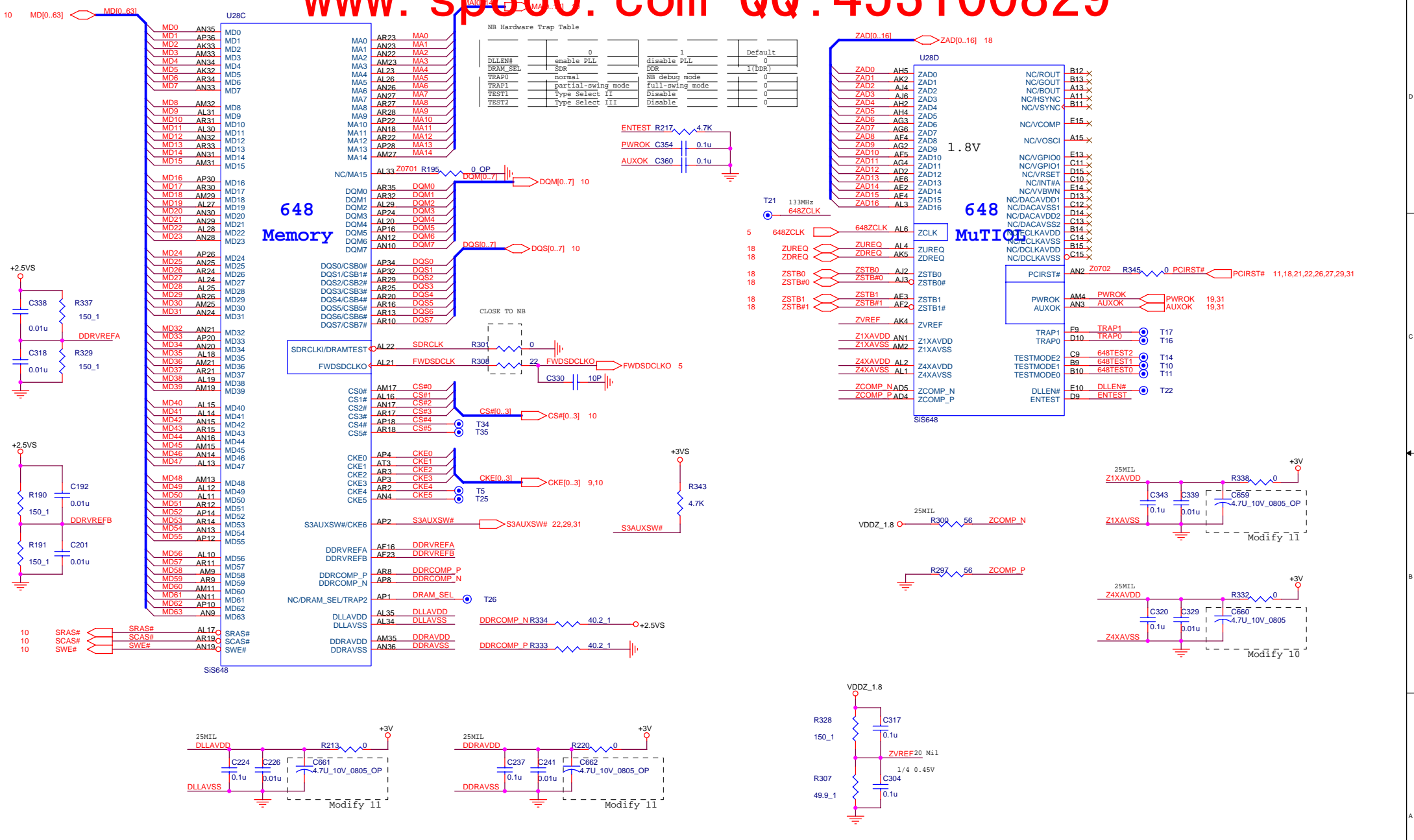

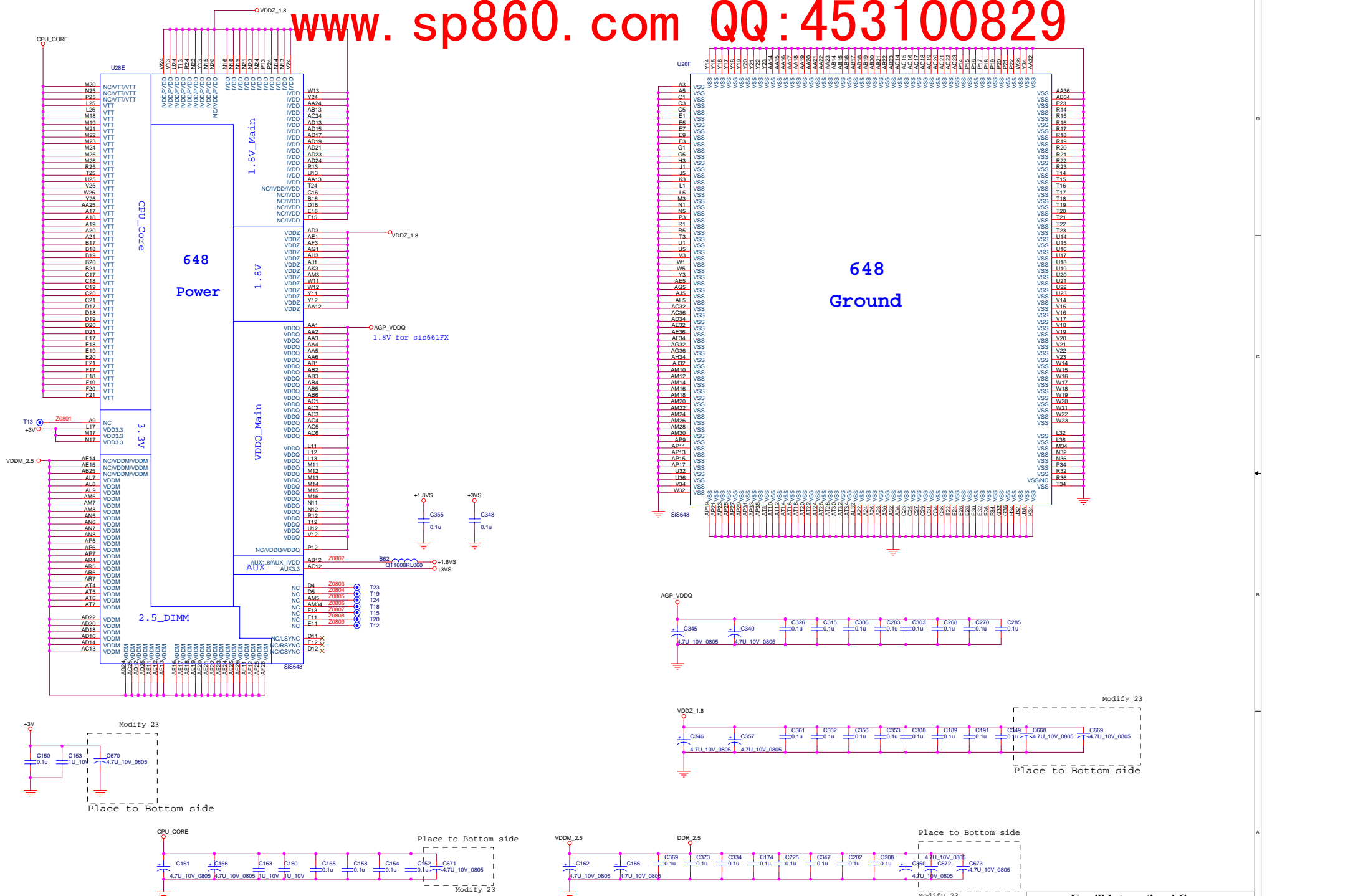

Unwill International Corp.		
File	755SA1	
Size	Document Number	Rev
2410	Si648 (POWER)	A
Date	Monday, December 08, 2003	Sheet 8 of 38

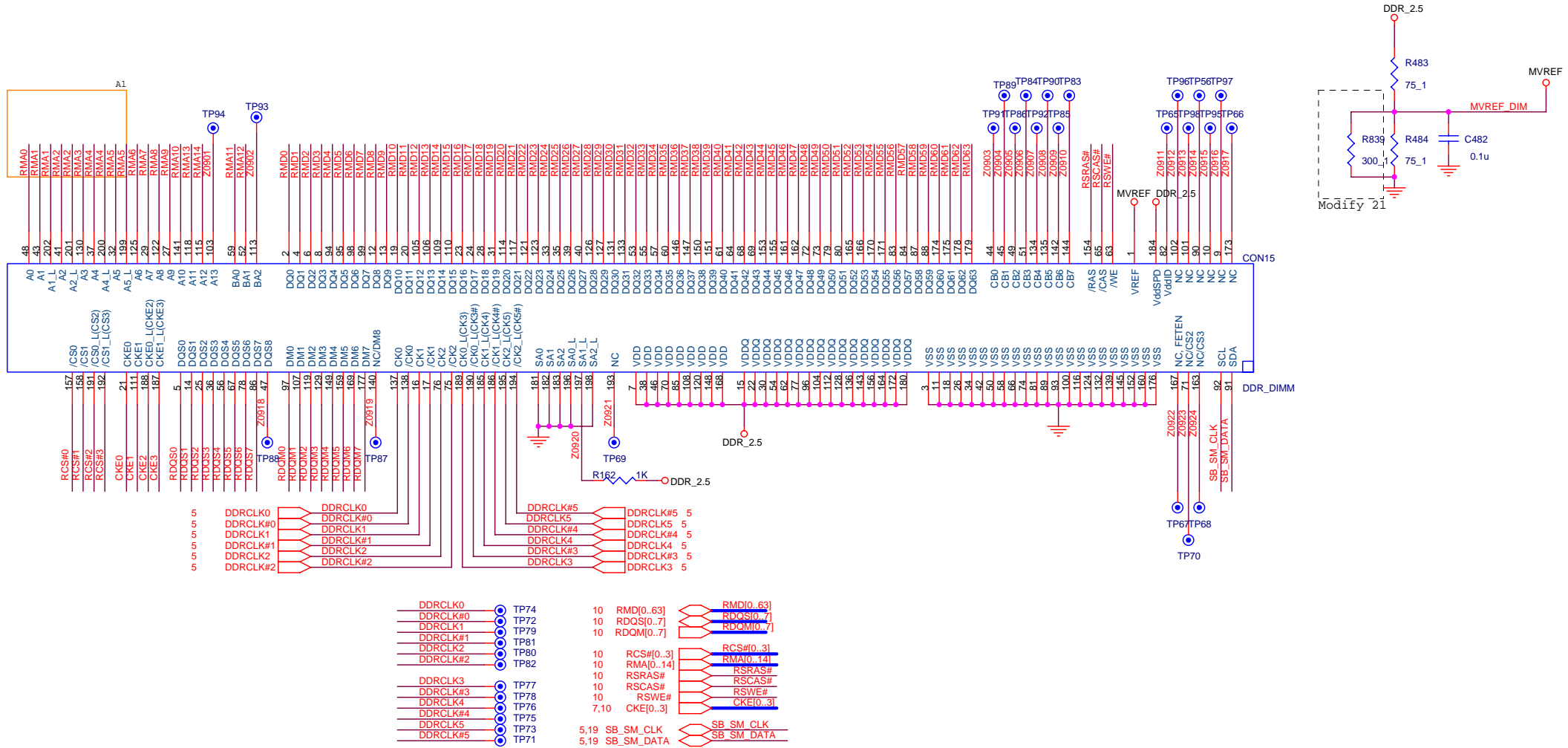

- | | | | | | |
|---|----------|------|------|-------------|-------------|
| 5 | DDRCLK0 | TP74 | 10 | RMD[0..63] | RMD[0..63] |
| 5 | DDRCLK#0 | TP72 | 10 | RDQS[0..7] | RDQS[0..7] |
| 5 | DDRCLK1 | TP79 | 10 | RDQM[0..7] | RDQM[0..7] |
| 5 | DDRCLK#1 | TP81 | 10 | RCS#[0..3] | RCS#[0..3] |
| 5 | DDRCLK2 | TP80 | 10 | RMA#[0..14] | RMA#[0..14] |
| 5 | DDRCLK#2 | TP82 | 10 | RSRAS# | RSRAS# |
| | | | 10 | RSCAS# | RSCAS# |
| | | | 10 | RSWE# | RSWE# |
| | | | 7,10 | CKE[0..3] | CKE[0..3] |
| | | | 5,19 | SB_SM_CLK | SB_SM_CLK |
| | | | 5,19 | SB_SM_DATA | SB_SM_DATA |

Unwill International Corp.		
Title 755SA1		
Size	Document Number DDR SLOT X 2	Rev A
Date:	Monday, December 08, 2003	Sheet 9 of 38

DDR PULL HIGH

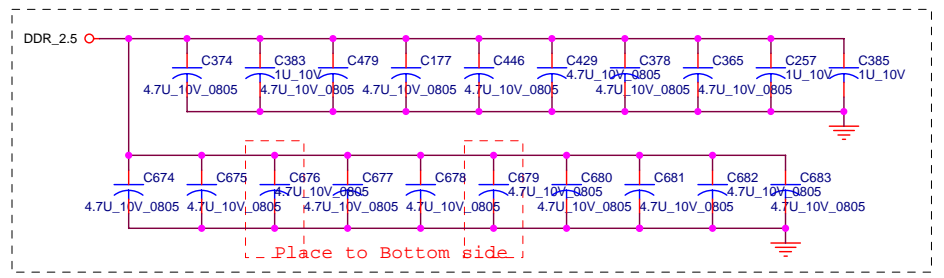
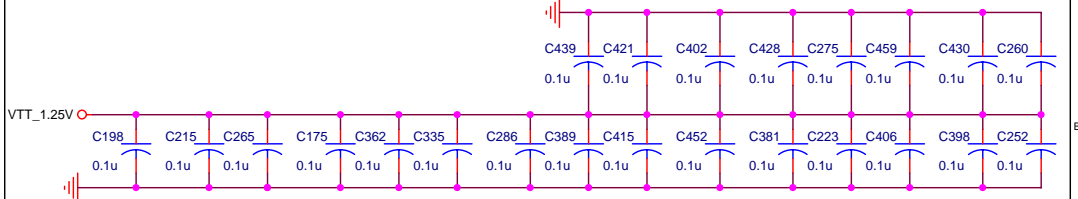
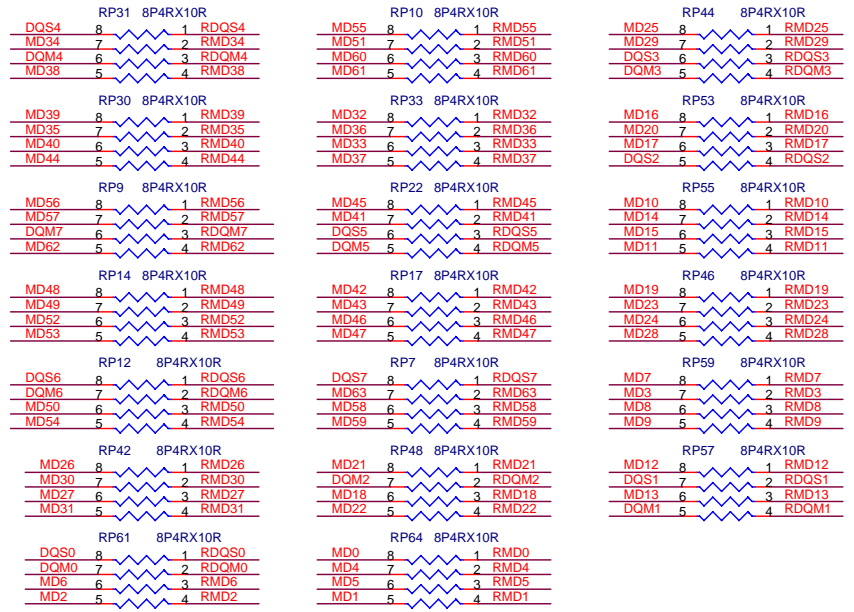
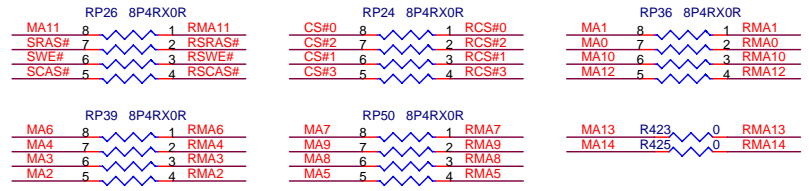
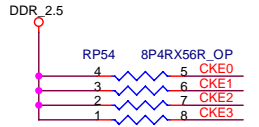
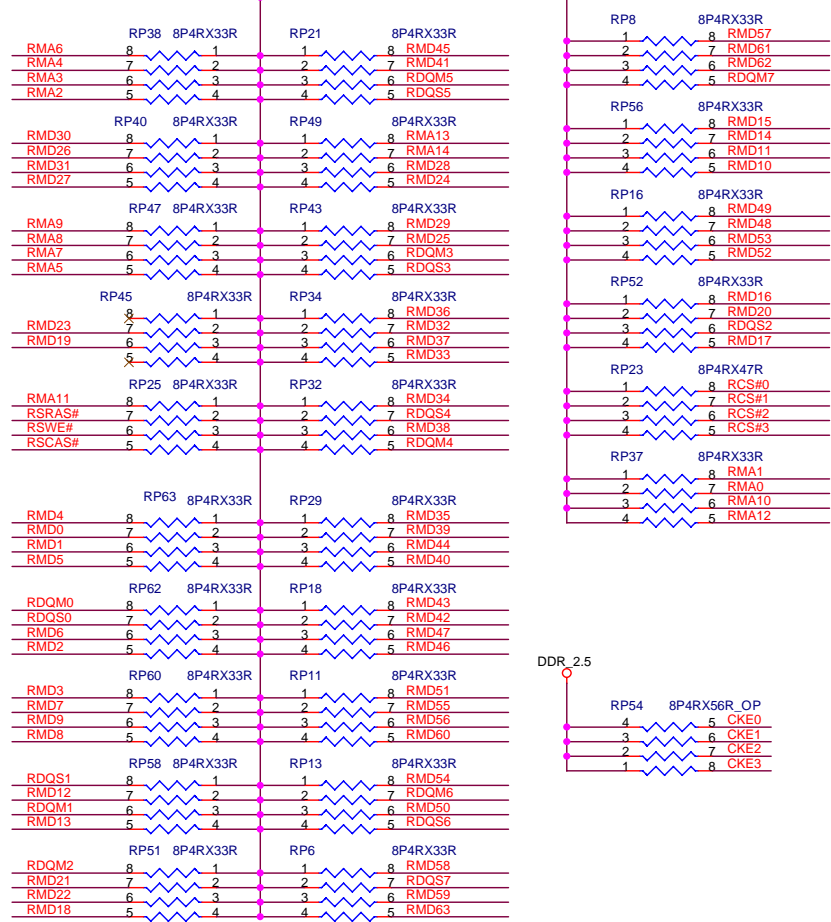

Unwill International Corp.		
755SA1		
Title		
Size	Document Number	Rev
	DDR PULL HIGH	A
Date:	Monday, December 08, 2003	Sheet 10 of 38

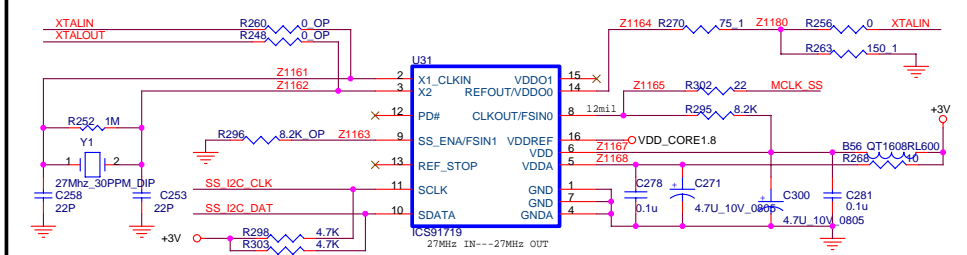
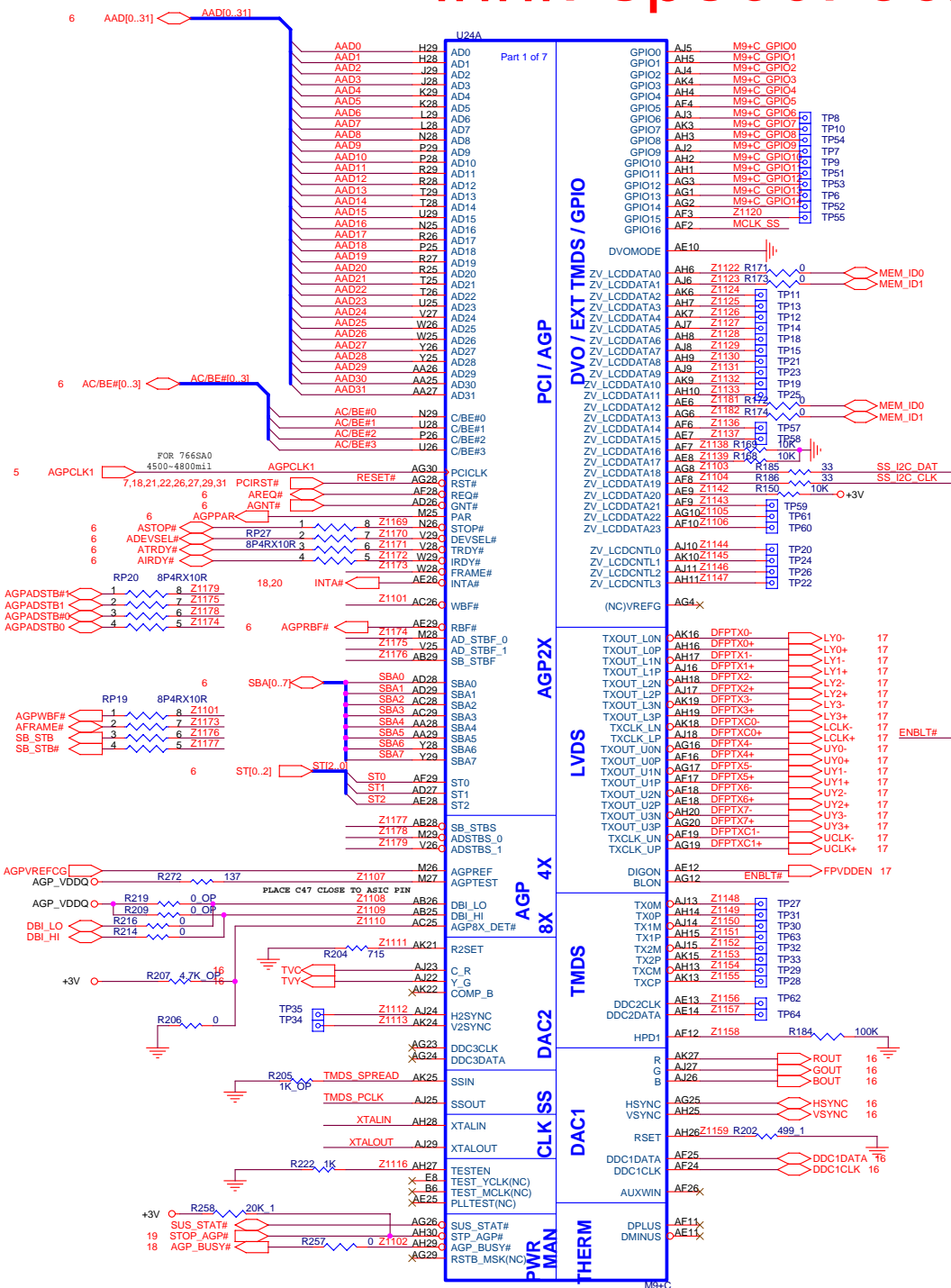

MEMORY	MEN_ID0	MEN_ID1
HYNIX	0	0
SAMSUNG	0	1
INFINEON	1	0
RESERVE	1	1

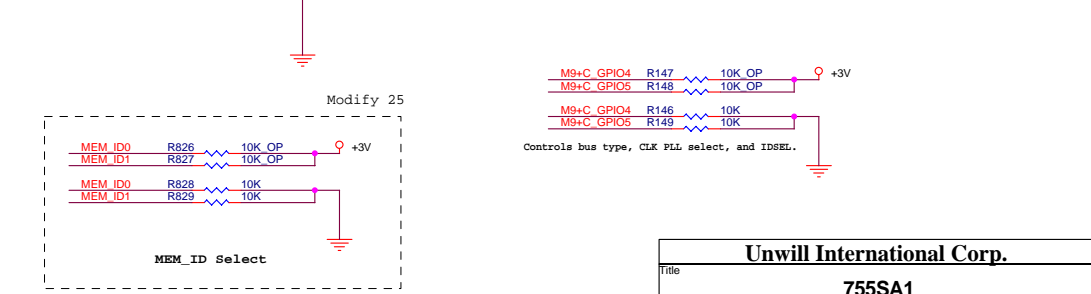
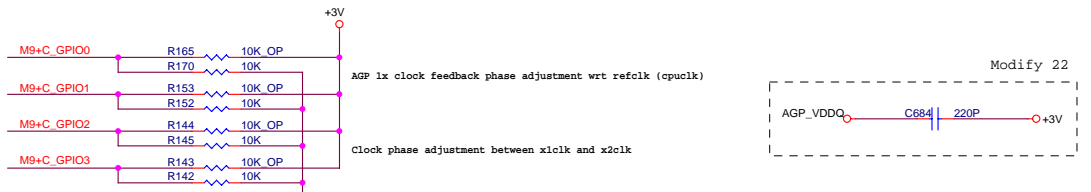
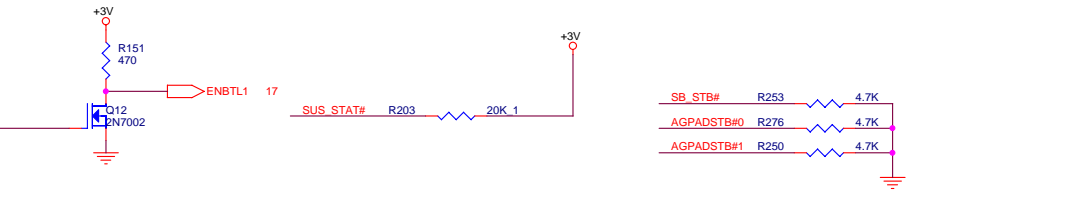
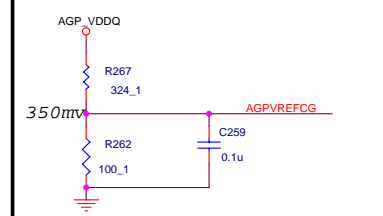

M9+C_B

M9+C_C

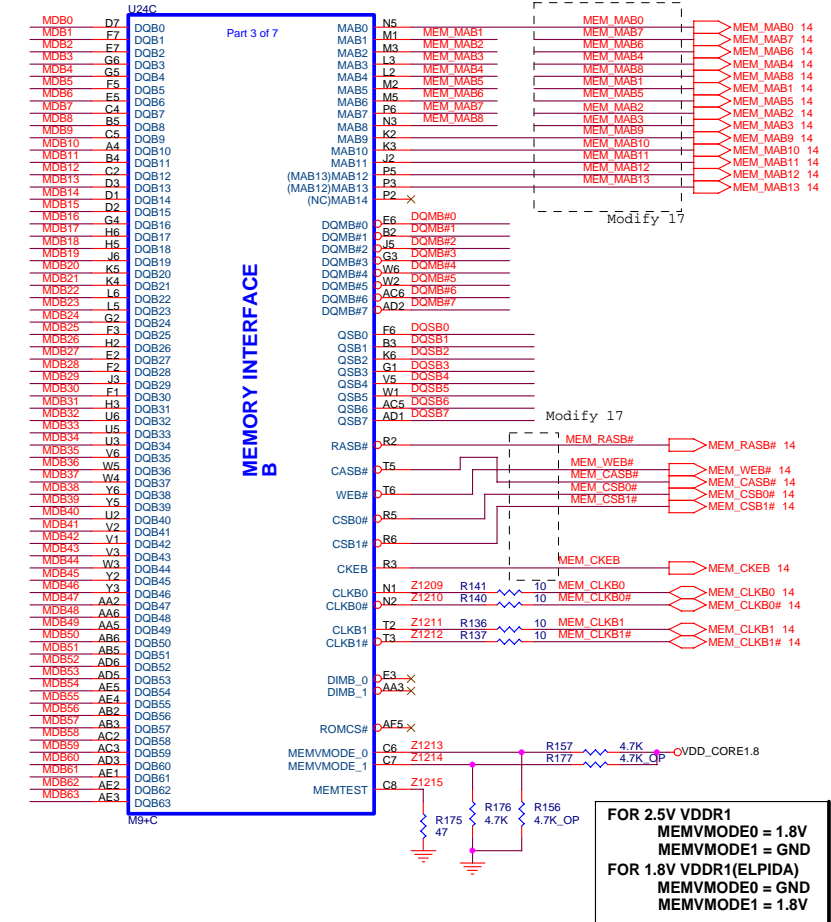
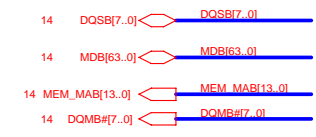
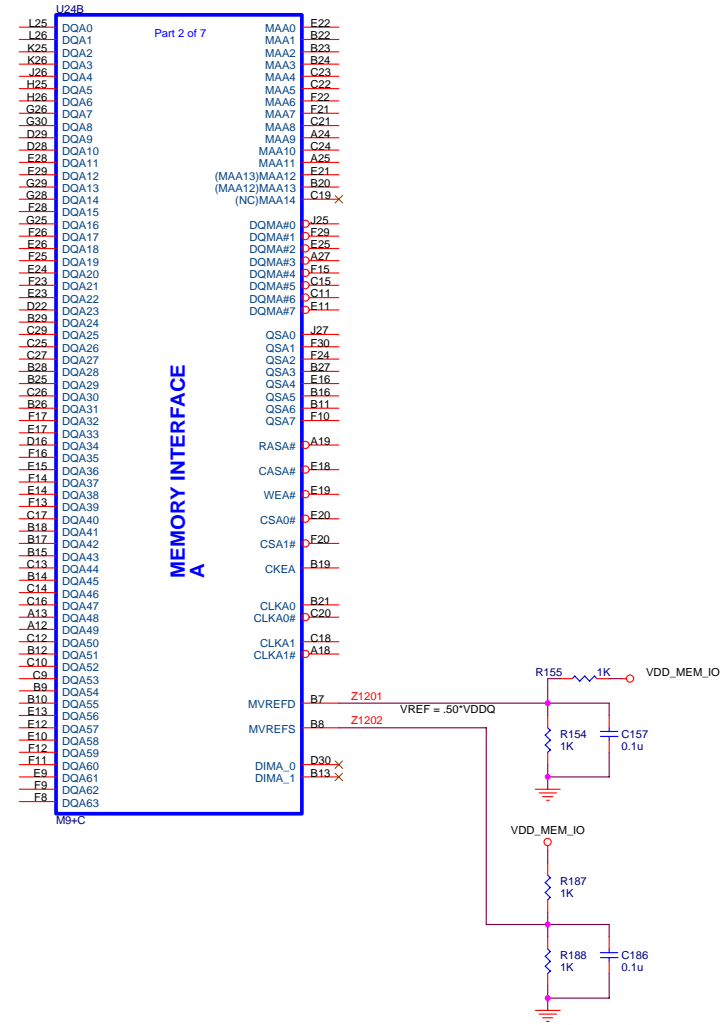

FOR 2.5V VDDR1
MEMVMODE0 = 1.8V
MEMVMODE1 = GND

FOR 1.8V VDDR1(ELPIDA)
MEMVMODE0 = GND
MEMVMODE1 = 1.8V

Unwill International Corp.		
Title		
755SA1		
Size	Document Number	Rev
	MOBILITY M9+C_B/C	A
Date:	Monday, December 08, 2003	Sheet 12 of 38

VDDR1(R4) IS CLKBFB ON M9+X AND IS A NC

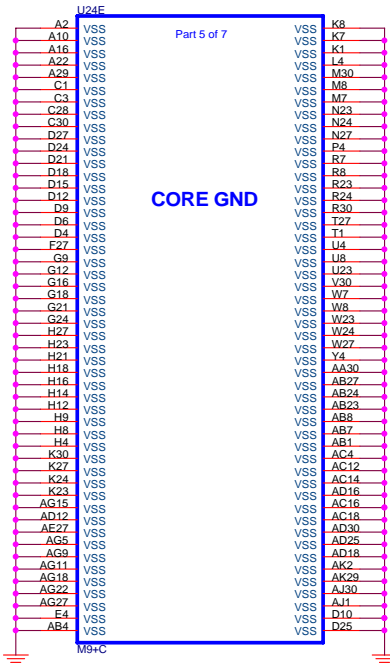
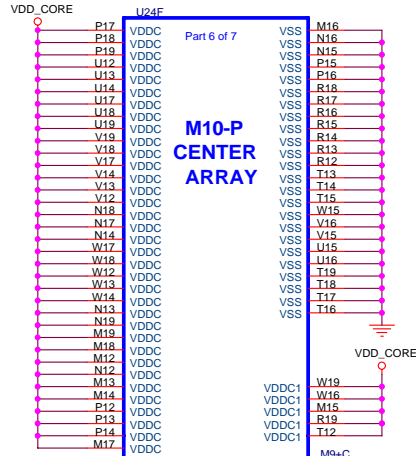
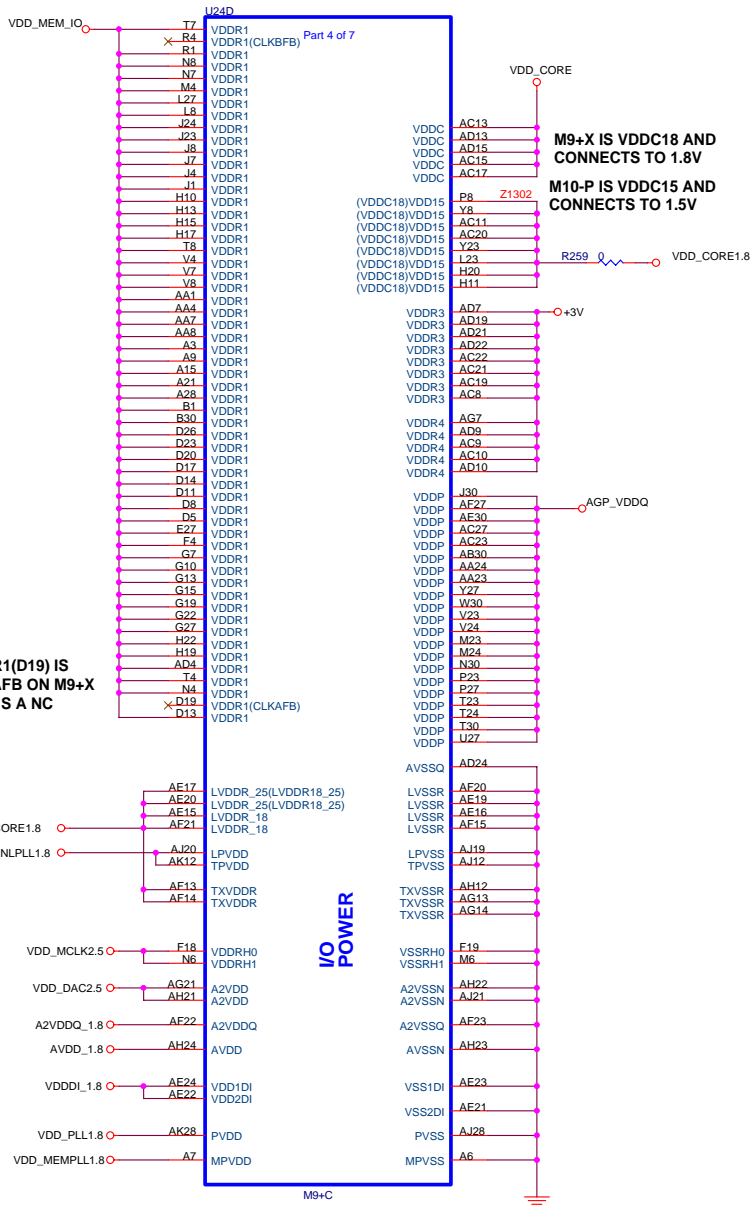

Unwill International Corp.		
Title		
755SA1		
Size	Document Number	Rev
	MOBILITY M9+C_D/E	A
Date:	Monday, December 08, 2003	Sheet 13 of 38

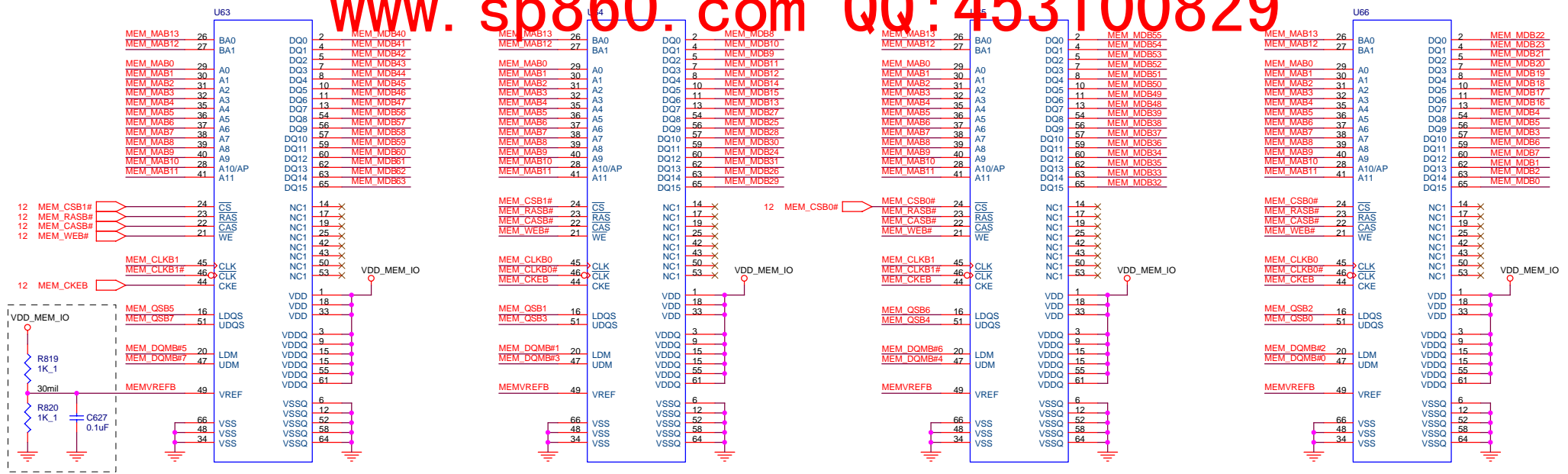

PLACE CLOSE TO MEMORY

PLACE CLOSE TO U63

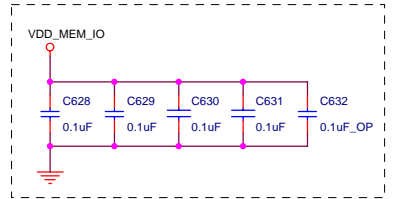

PLACE CLOSE TO U64

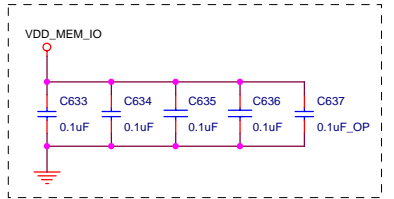

PLACE CLOSE TO U65

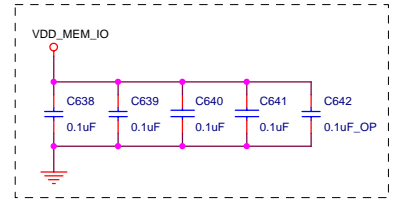

PLACE CLOSE TO U66

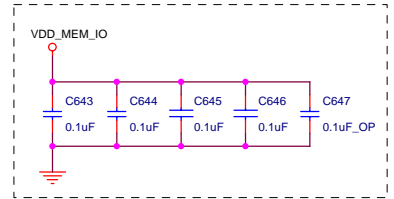

PLACE CLOSE TO MEMORY

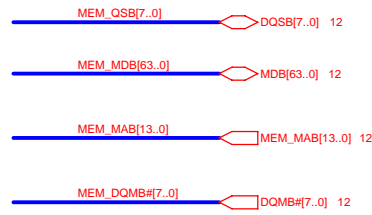
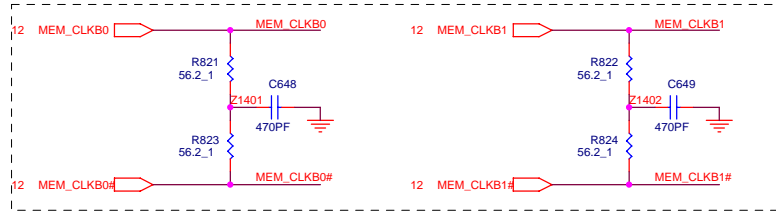

Unwill International Corp.		
755SA1		
Title		Rev A
Size	Document Number	
	2410	VRAM
Date:	Monday, December 08, 2003	Sheet 14 of 38

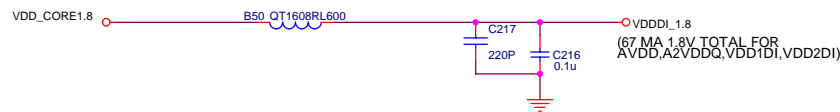
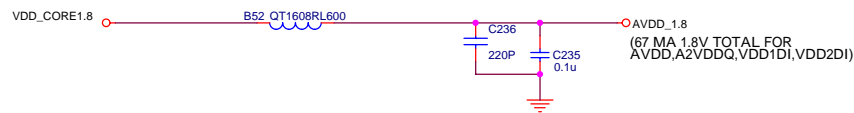
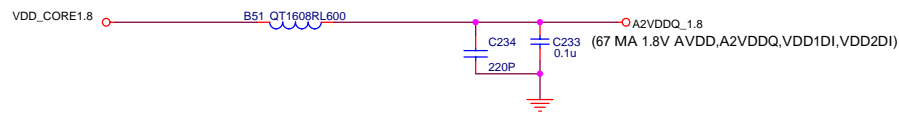
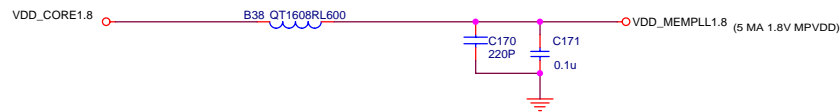
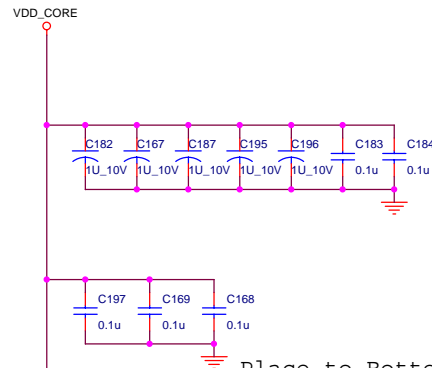
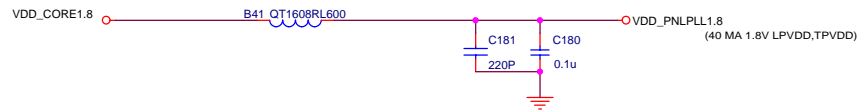
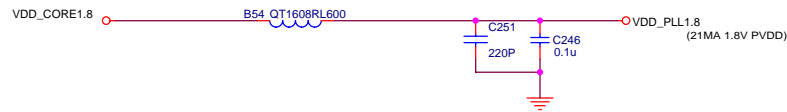
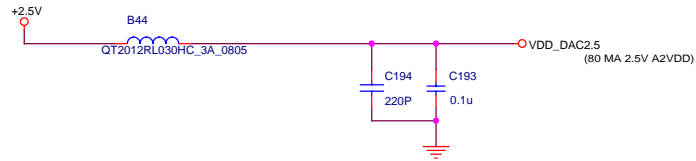
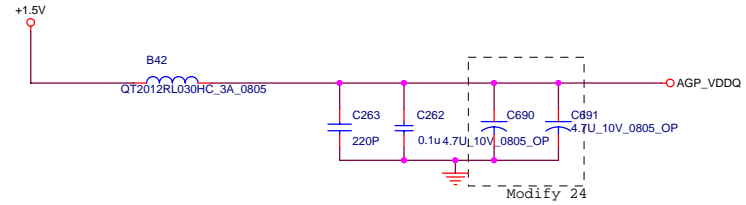
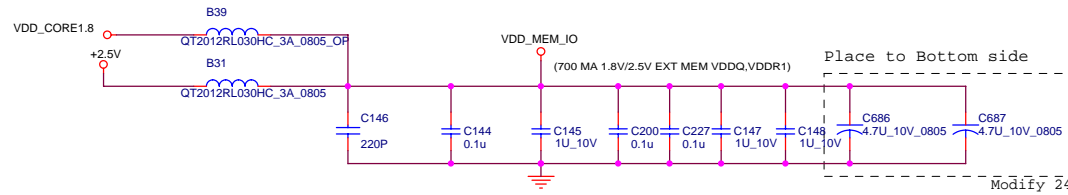
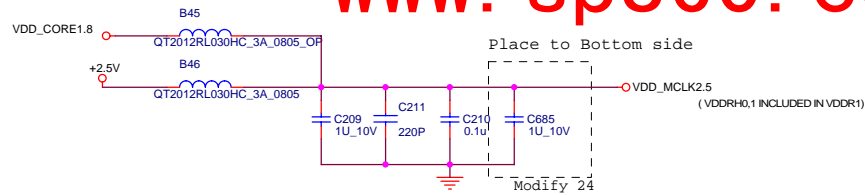

Unwill International Corp.		
Title		
755SA1		
Size	Document Number	Rev
	MOBILITY M9+C POWER	A
Date:	Monday, December 08, 2003	Sheet 15 of 38

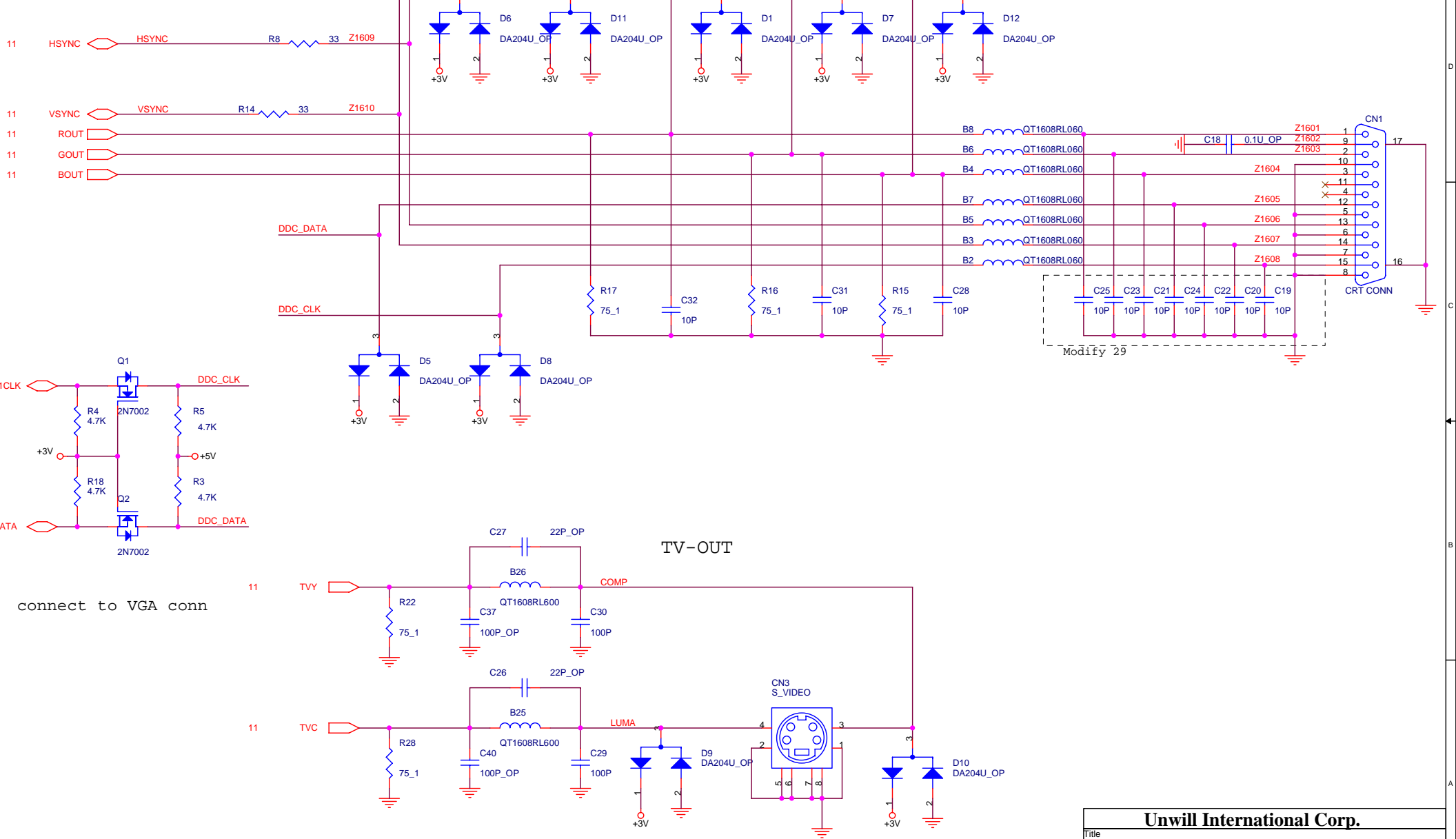

connect to VGA conn

Unwill International Corp.		
Title		
755SA1		
Size	Document Number	Rev
	CRT & TV-OUT	A
Date:	Monday, December 08, 2003	Sheet 16 of 38

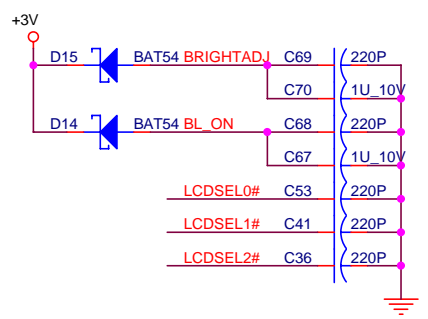
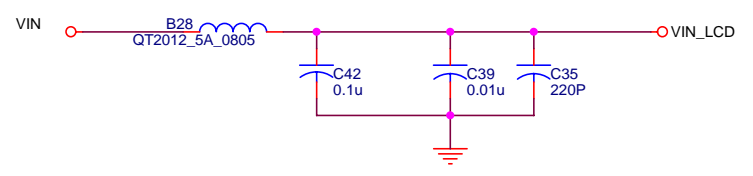
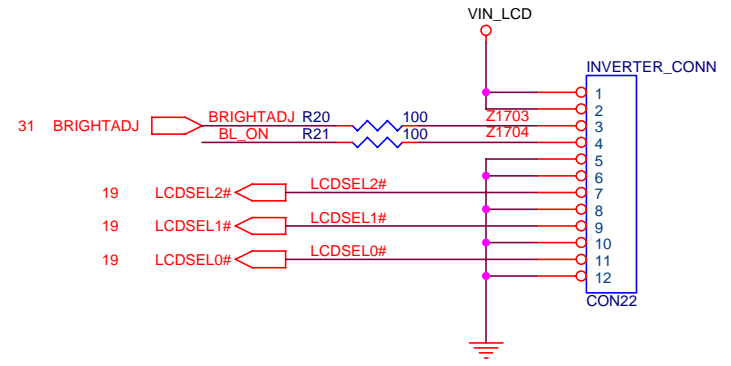
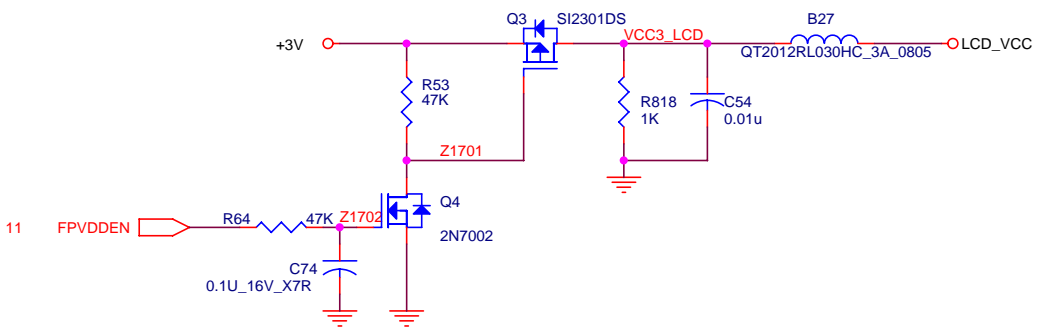
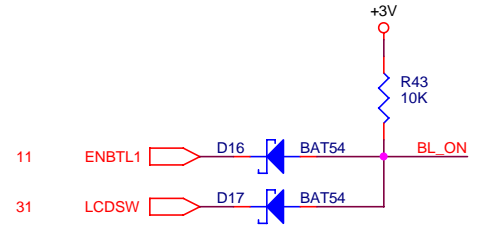
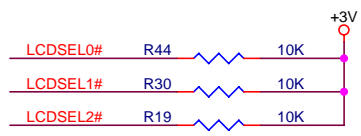
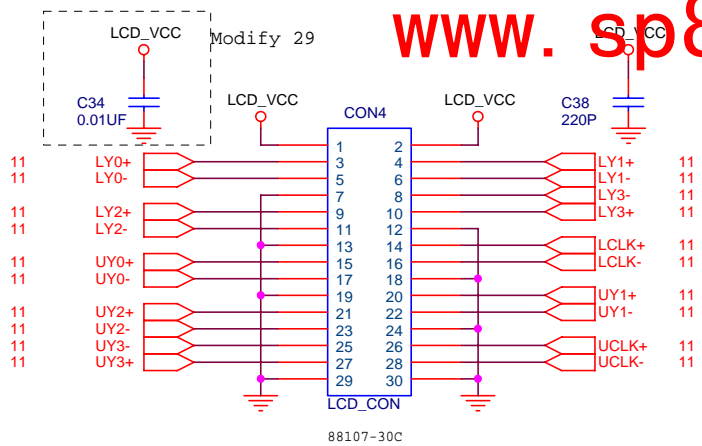

PANNEL SELECT

LCD TYPE	18Bit XGA	18Bit SXGA	18Bit SXGA+	Reserve	24Bit XGA	24Bit SXGA	24Bit SXGA+	Reserve
LCDSEL2	1	1	1		0	0	0	
LCDSEL1	1	1	0		1	1	0	
LCDSEL0	1	0	0		1	0	0	

Unwill International Corp.			
Title			
755SA1			
Size	Document Number		Rev
	LVDS CONN		A
Date:	Monday, December 08, 2003	Sheet	17 of 38

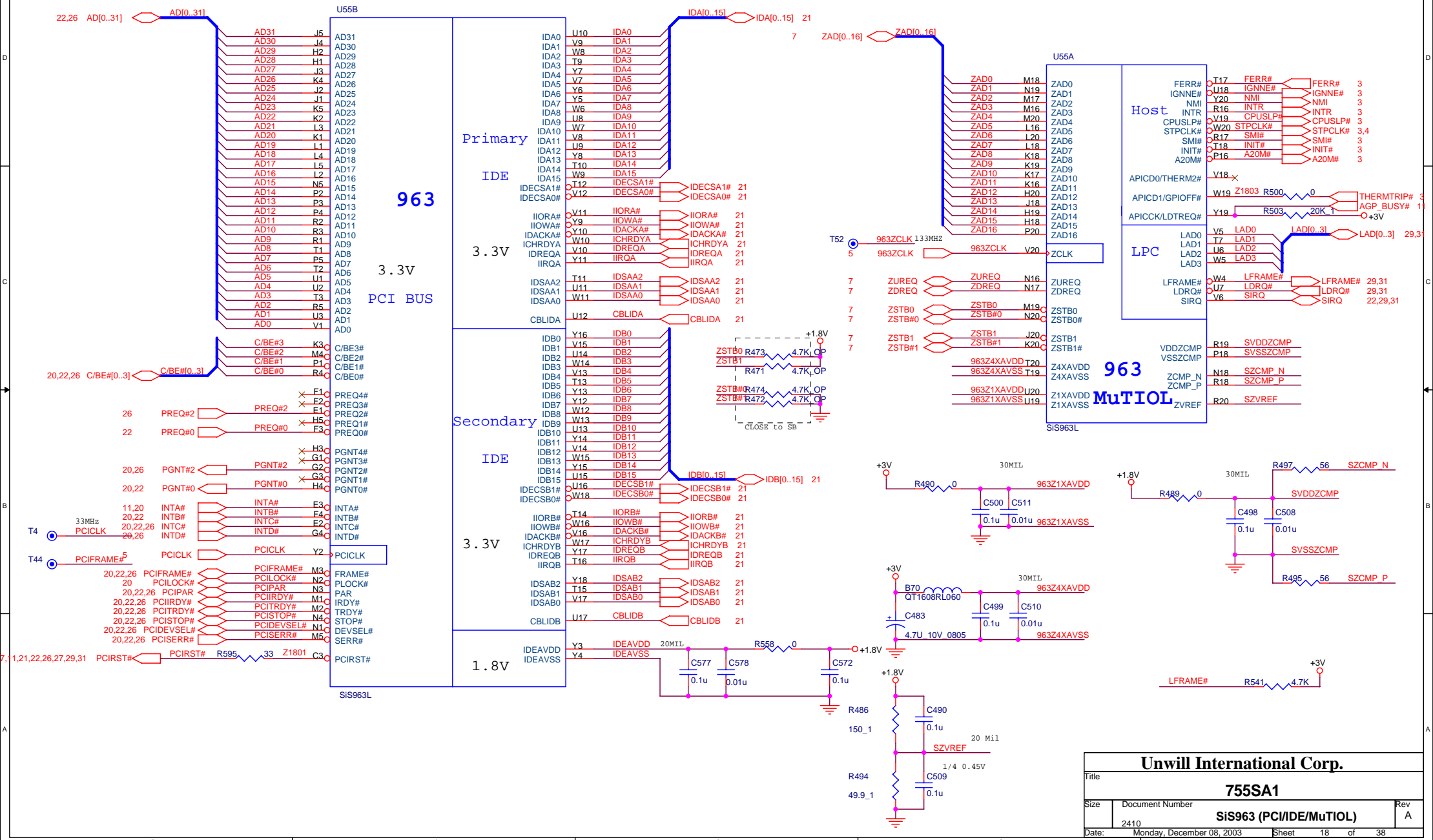

Unwill International Corp.			
Title			
755SA1			
Size	Document Number	Rev	
	SiS963 (PCI/IDE/MuTIOL)	A	
Date:	Monday, December 08, 2003	Sheet	18 of 38

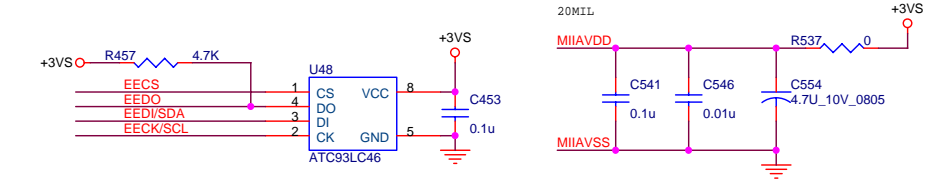
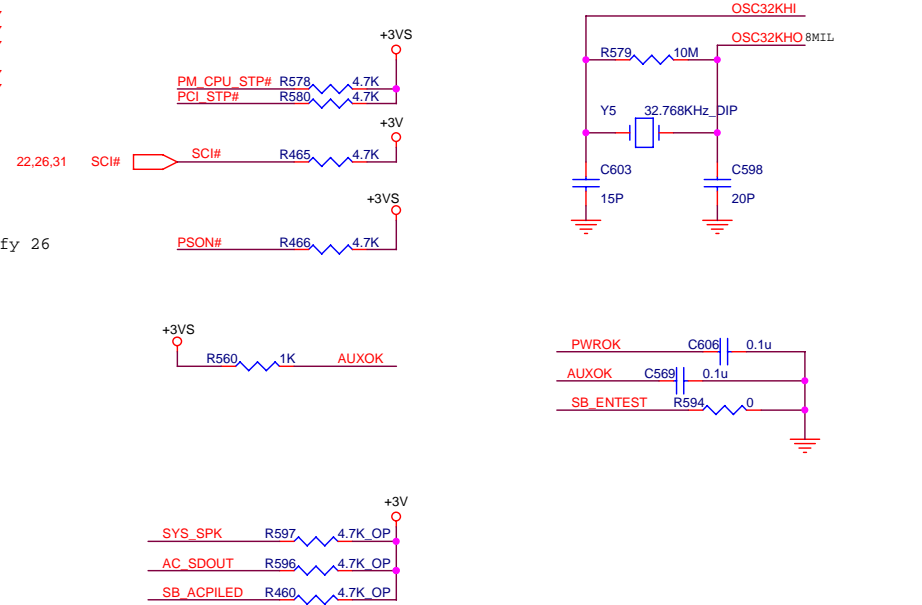
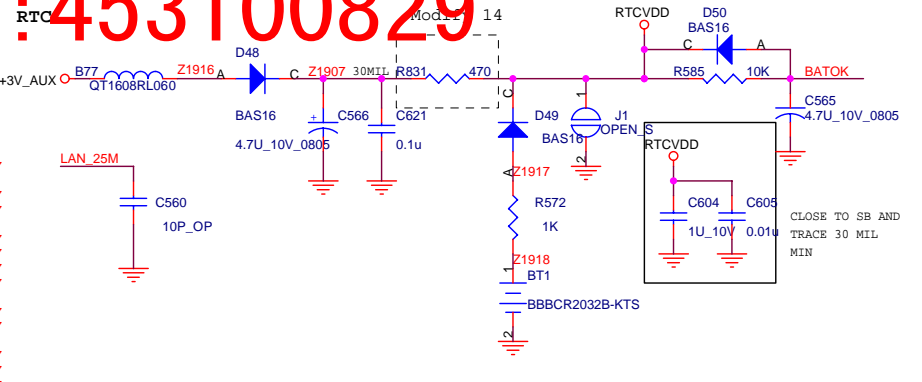
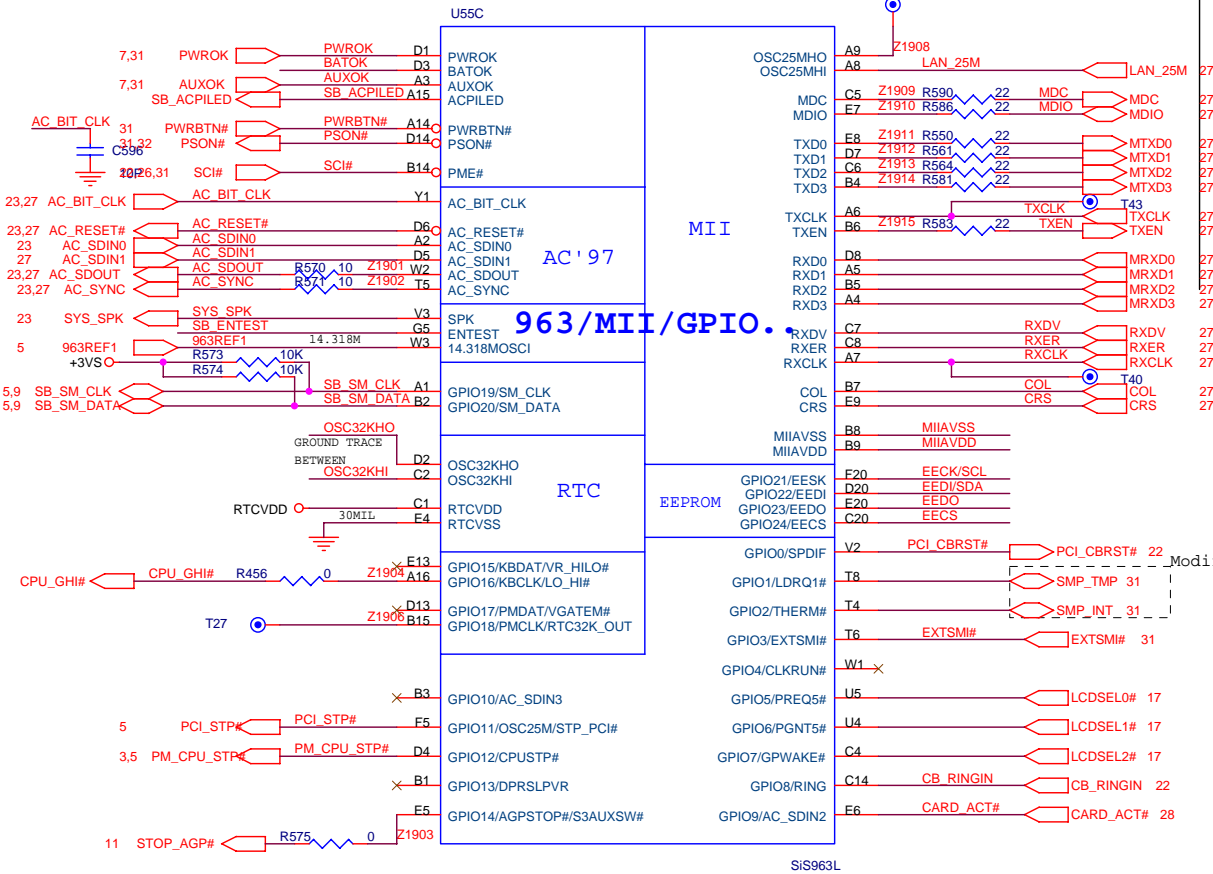

Unwill International Corp.			
Title			
755SA1			
Size	Document Number	Rev	
		Si963 (GPIO)	
Date:	Monday, December 08, 2003	Sheet	19 of 38

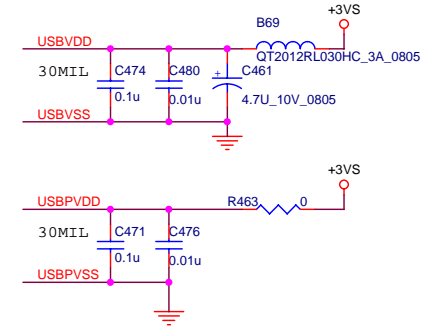
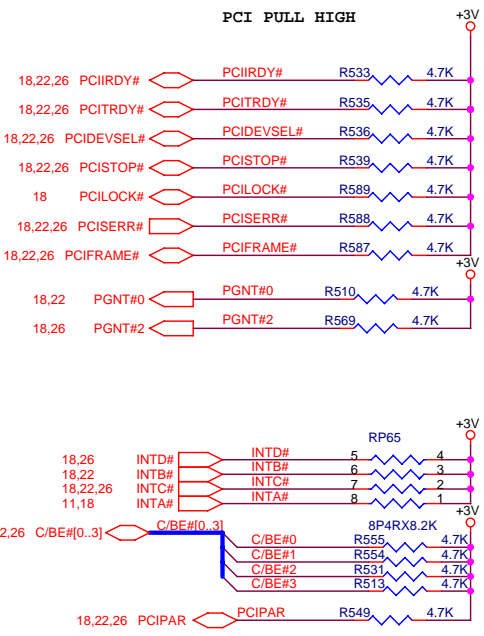
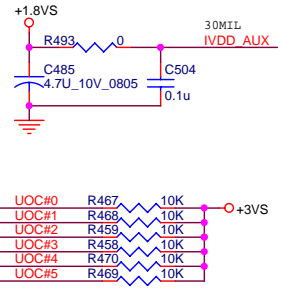
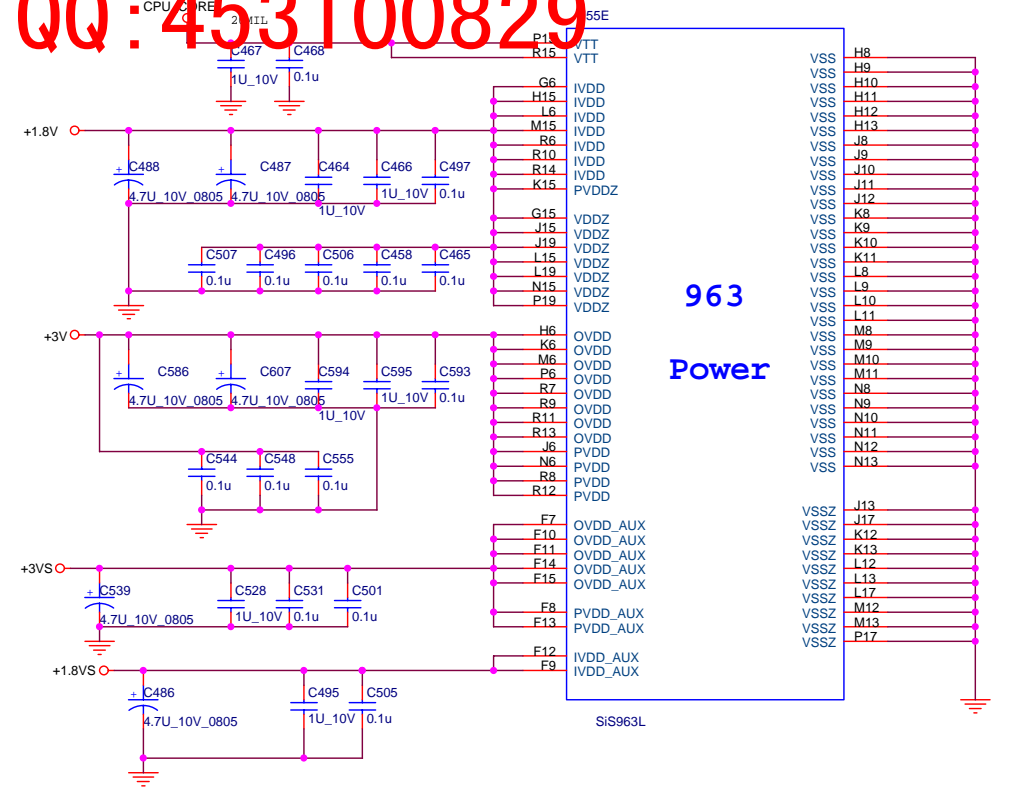
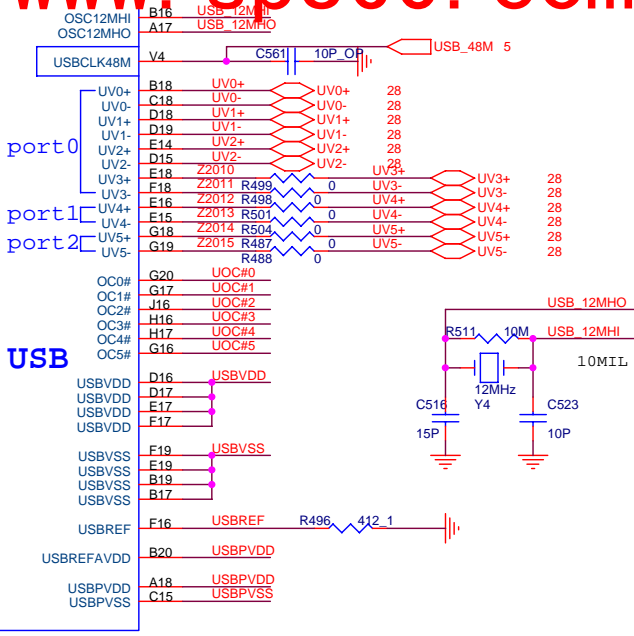
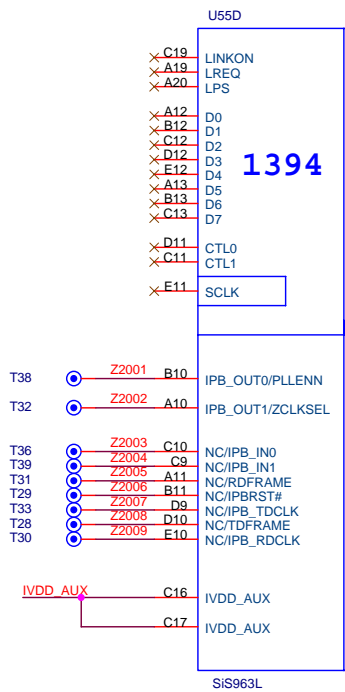

Unwill International Corp.			
Title			
755SA1			
Size	Document Number	Rev	
	SIS963 (USB/1394/POWER)	A	
Date:	Monday, December 08, 2003	Sheet	20 of 38

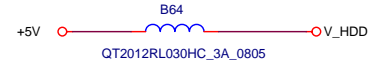
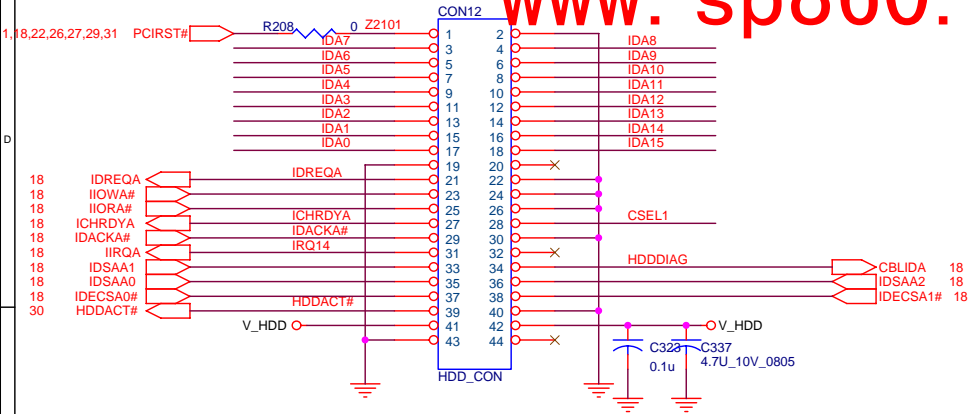

CSEL : Master = 0 / Slave = 1

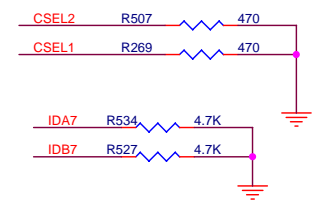

Primary Channel

SiS963 INTEGRATE TERMINATION FOR IDE CHANNEL
Check Register Value setting

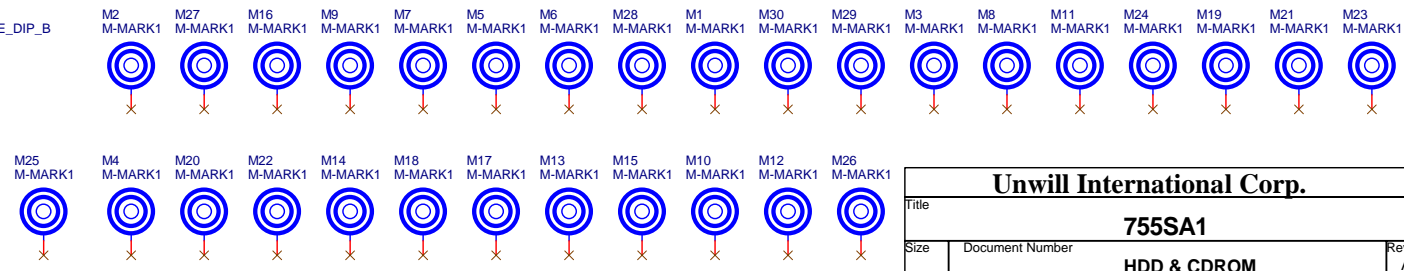
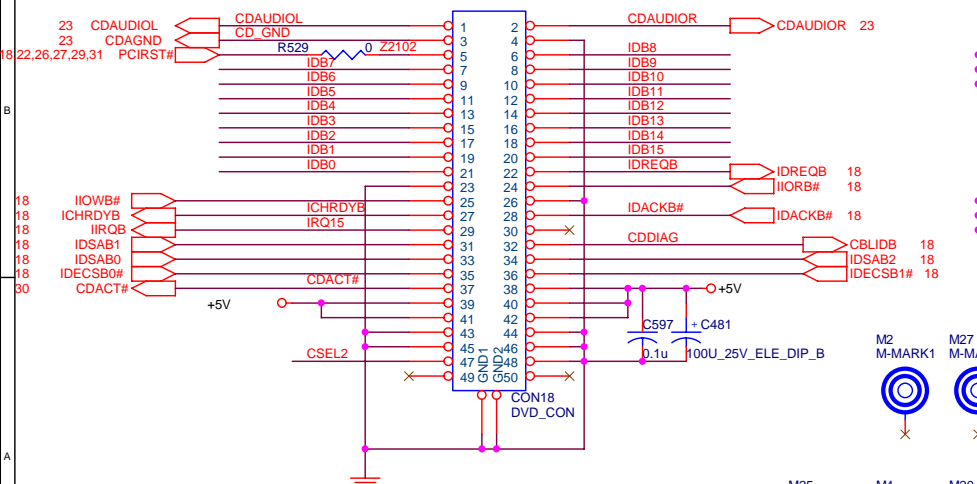
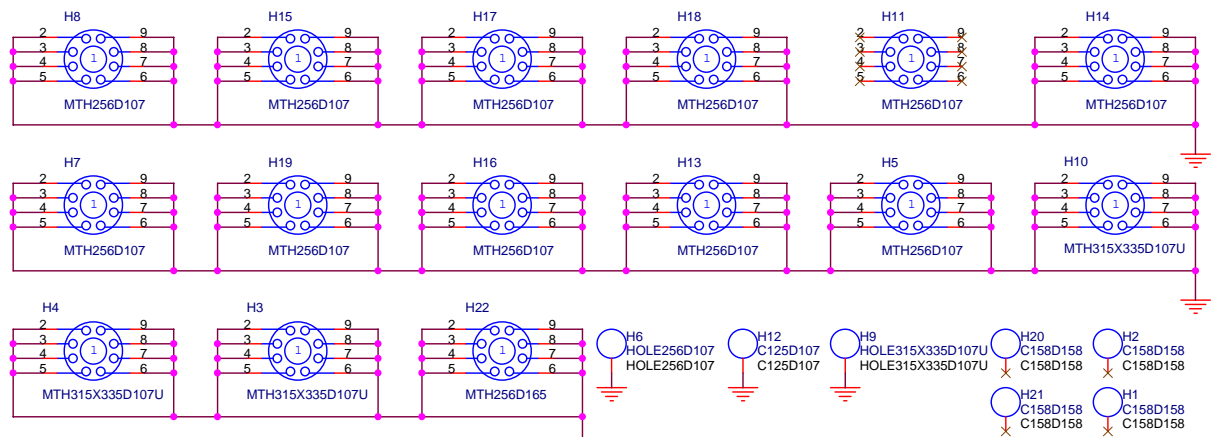
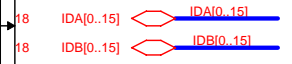

Secondary Channel

Unwill International Corp.		
755SA1		
Title	755SA1	
Size	Document Number	Rev
	HDD & CDROM	A
Date:	Monday, December 08, 2003	Sheet 21 of 38

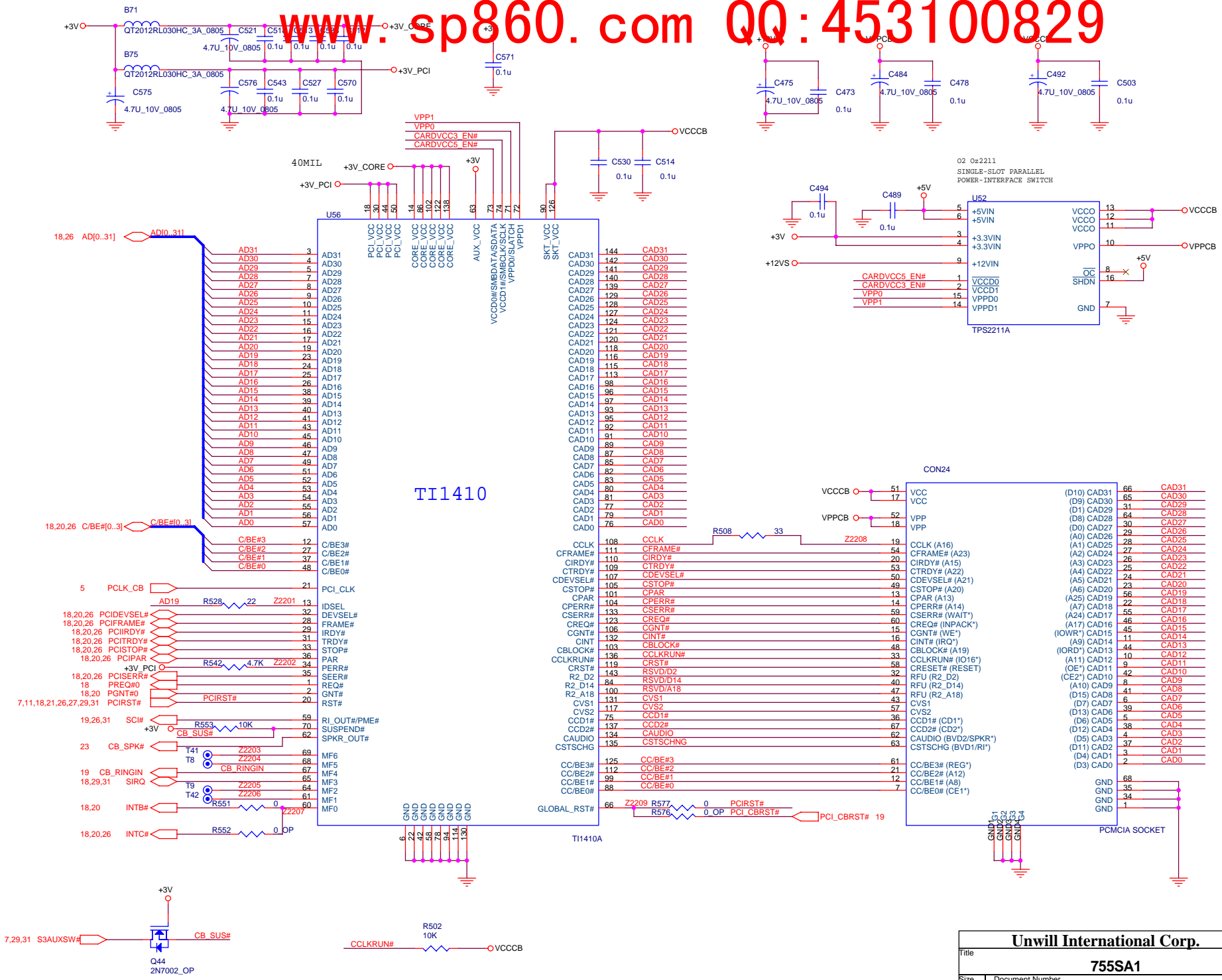

Unwill International Corp.		
755SA1		
Size	Document Number	Rev
2410	CARBUS TI1410	A
Date:	Monday, December 08, 2003	Sheet 22 of 38

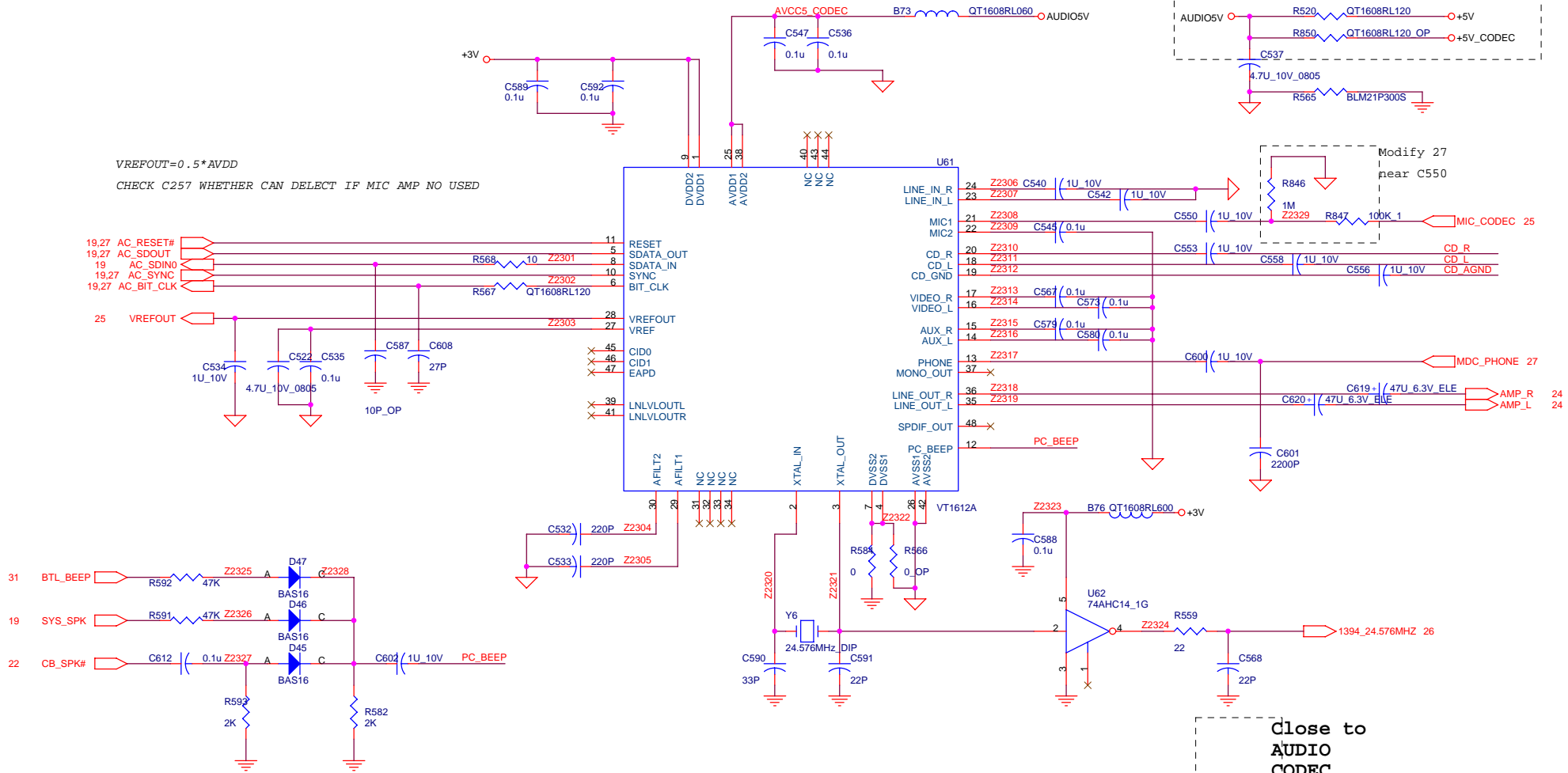

VREFOUT=0.5*AVDD
CHECK C257 WHETHER CAN DELECT IF MIC AMP NO USED

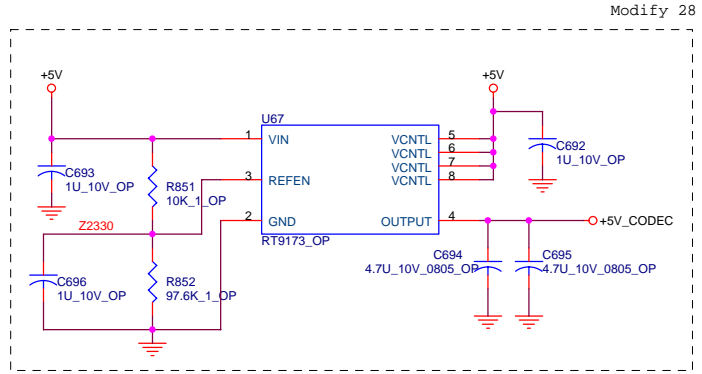
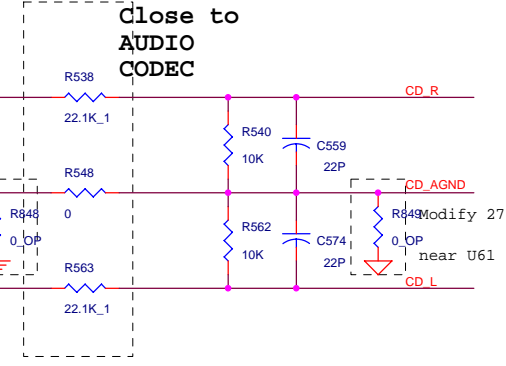
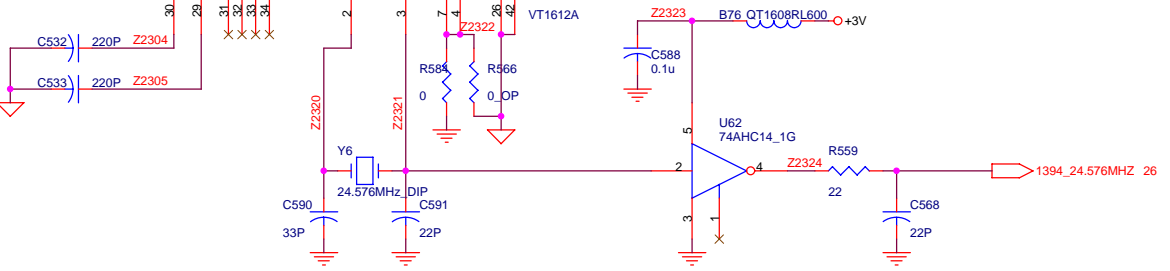
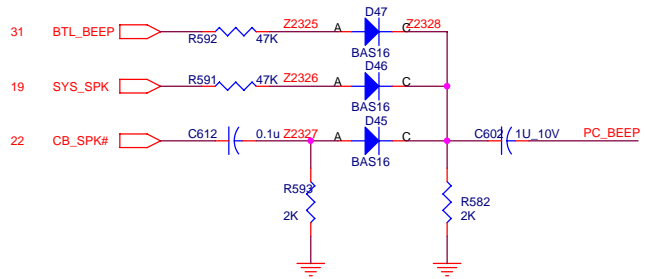
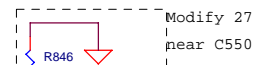
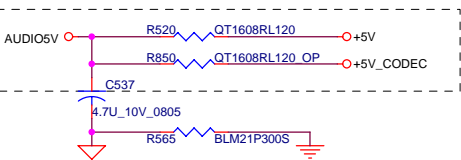

PIN45	ID0	PIN46	ID1	MASTER OR SLAVE
NC		NC		MASTER
GROUND		NC		SLAVE
NC		GROUND		SLAVE
GROUND		GROUND		SLAVE

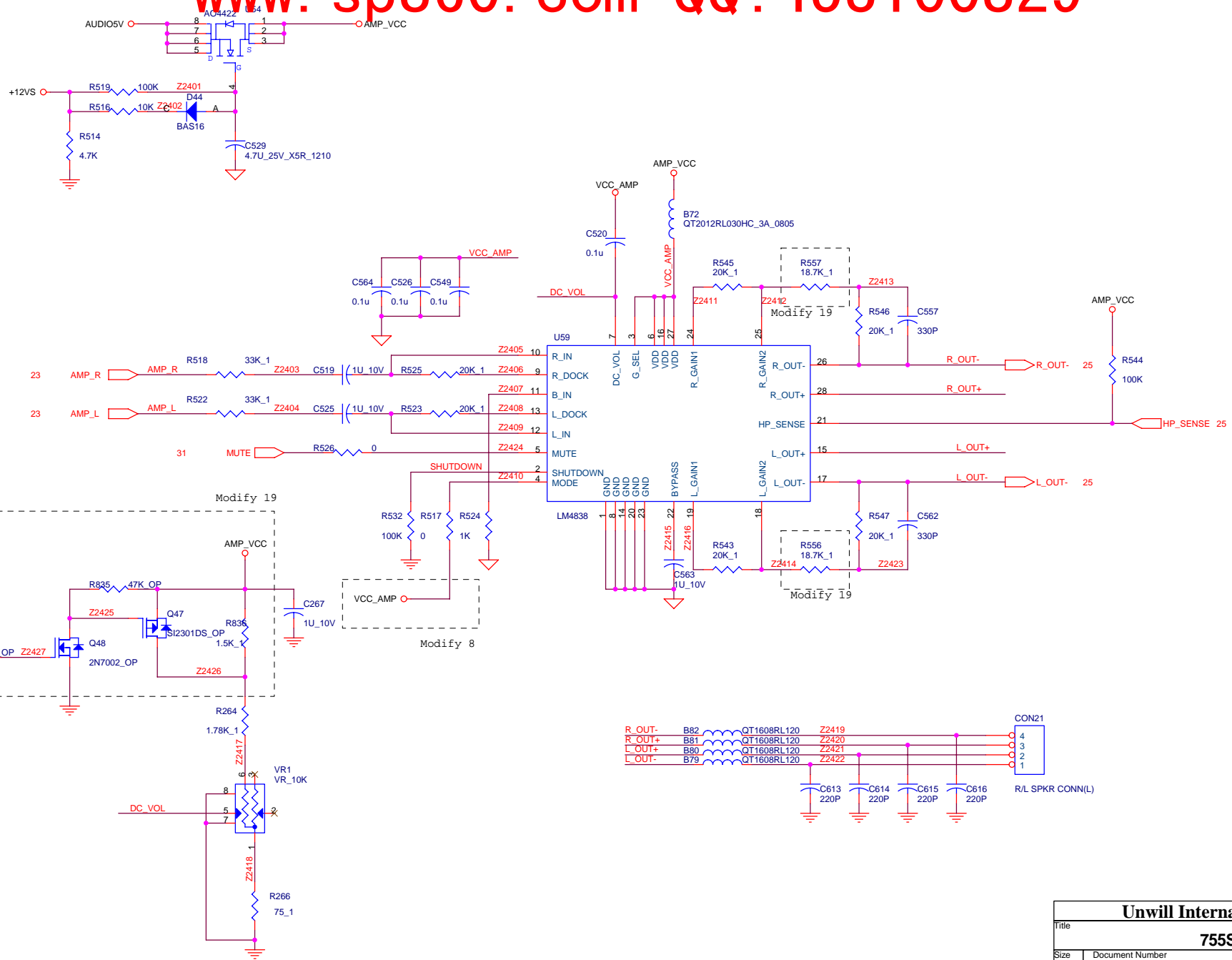

Unwill International Corp.		
755SA1		
Size	Document Number	Rev
2410	AMPLIFIER (LM4835)	A
Date:	Monday, December 08, 2003	Sheet 24 of 38

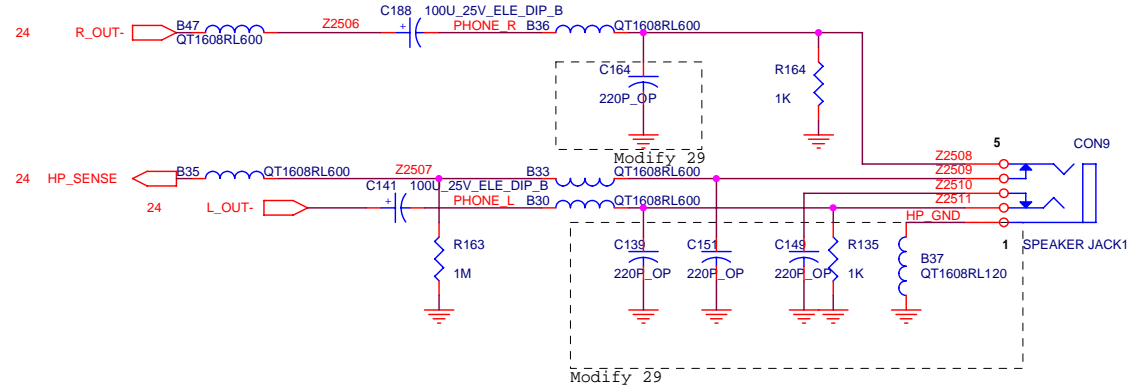
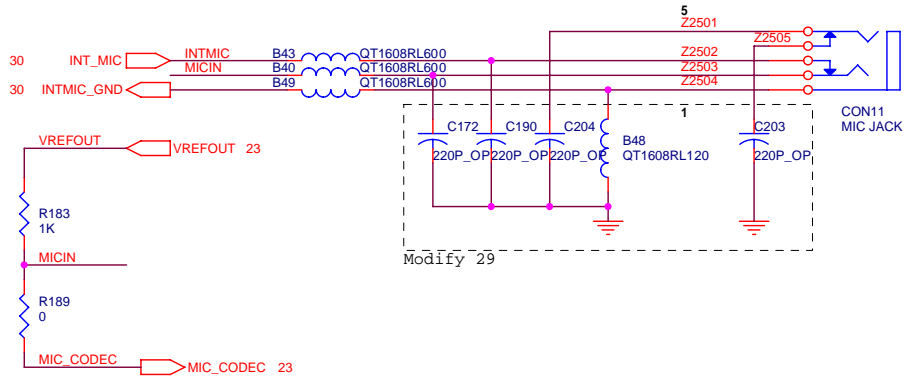

FOR DISCRETE VGA

CPU FAN CONTROL

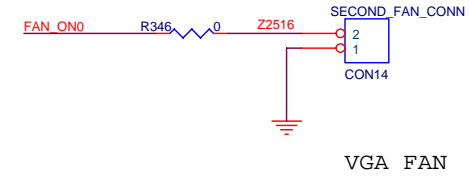
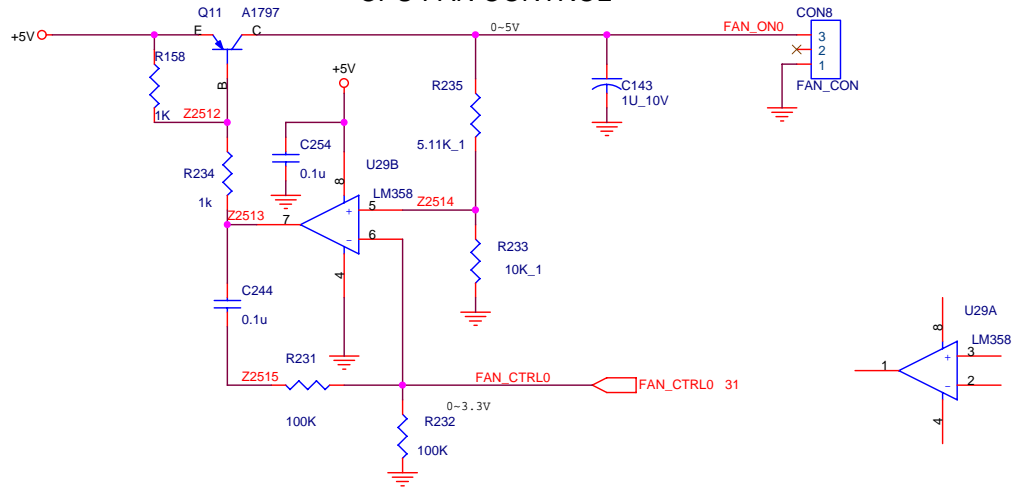

VGA FAN

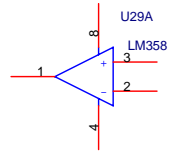

Unwill International Corp.

Title			755SA1		
Size	Document Number	PHONE & MIC JACK & FAN			Rev
	2410				A
Date:	Monday, December 08, 2003	Sheet	25	of	38

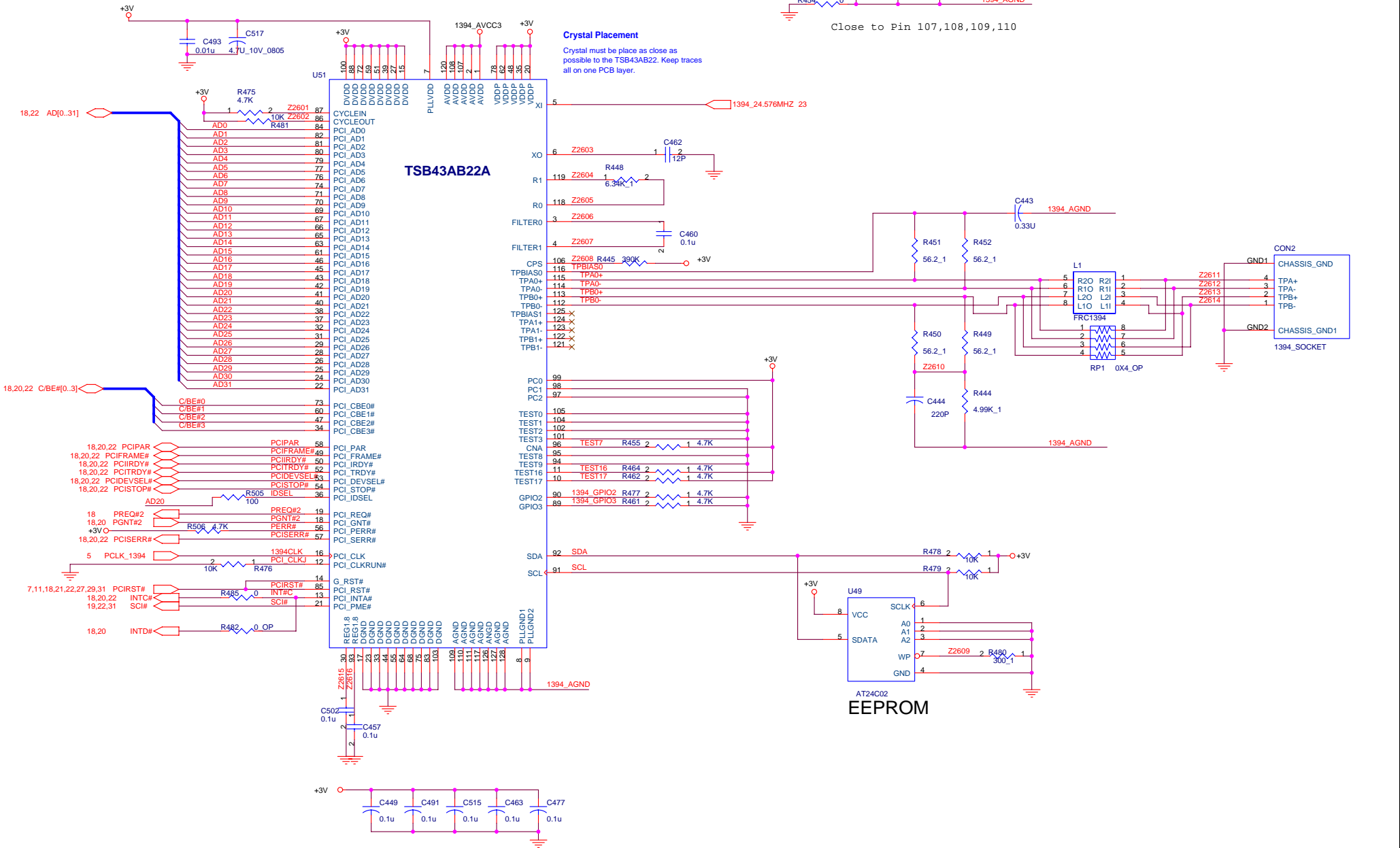

Unwill International Corp.		
Title	755SA1	
Size	Document Number	Rev
	IEEE1394 TSB43AB22	A
Date:	Monday, December 08, 2003	Sheet 26 of 38

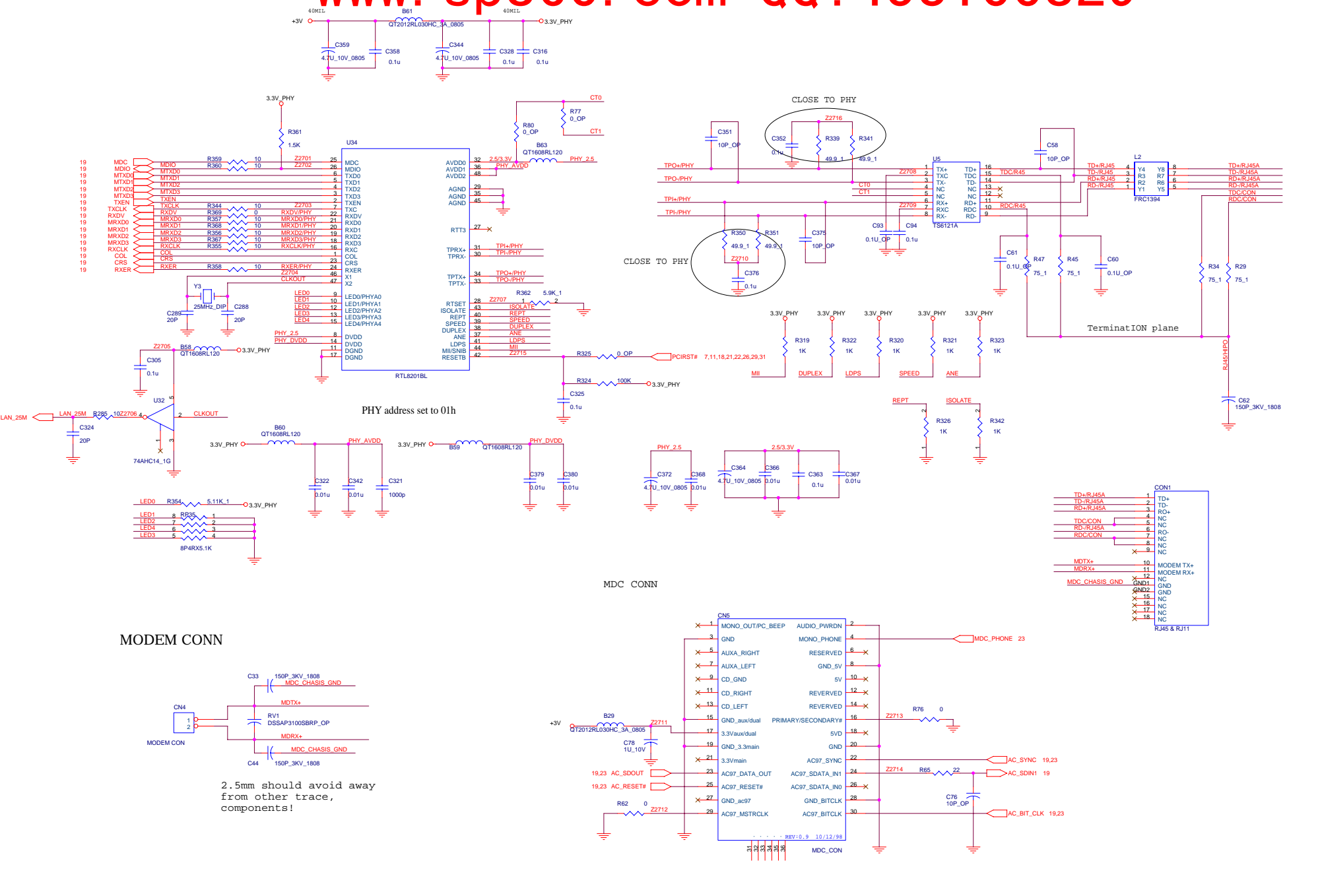

MODEM CONN

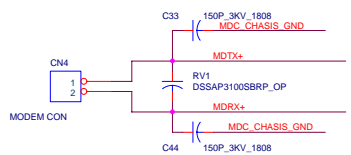

2.5mm should avoid away from other trace, components!

MDC CONN

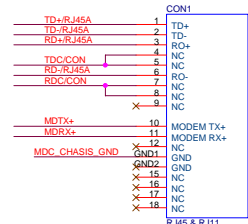
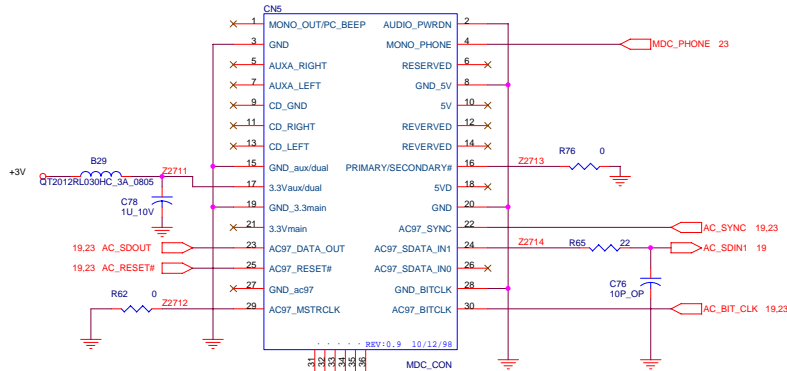

Unwill International Corp.			
File	755SA1		
Size	Document Number	LAN RTL8201BL & MDC	Rev A
Date	2410	Monday, December 08, 2003	Sheet 27 of 38

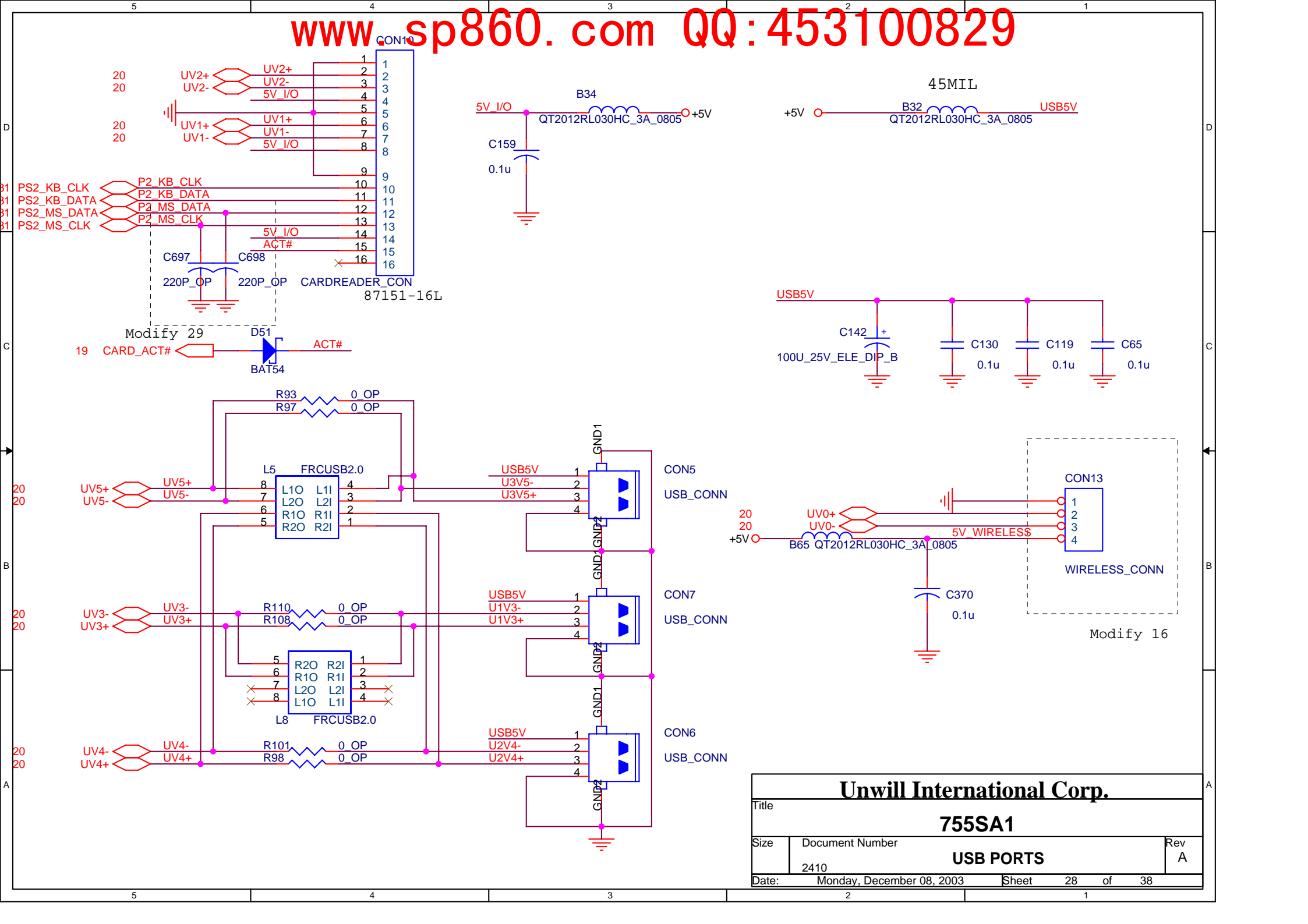

Unwill International Corp.		
Title		
755SA1		
Size	Document Number	Rev
	2410	A
Date:	Monday, December 08, 2003	Sheet 28 of 38

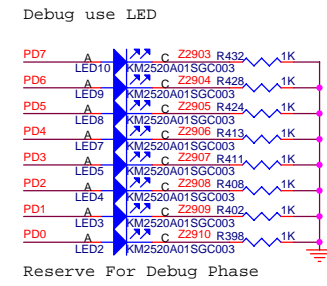
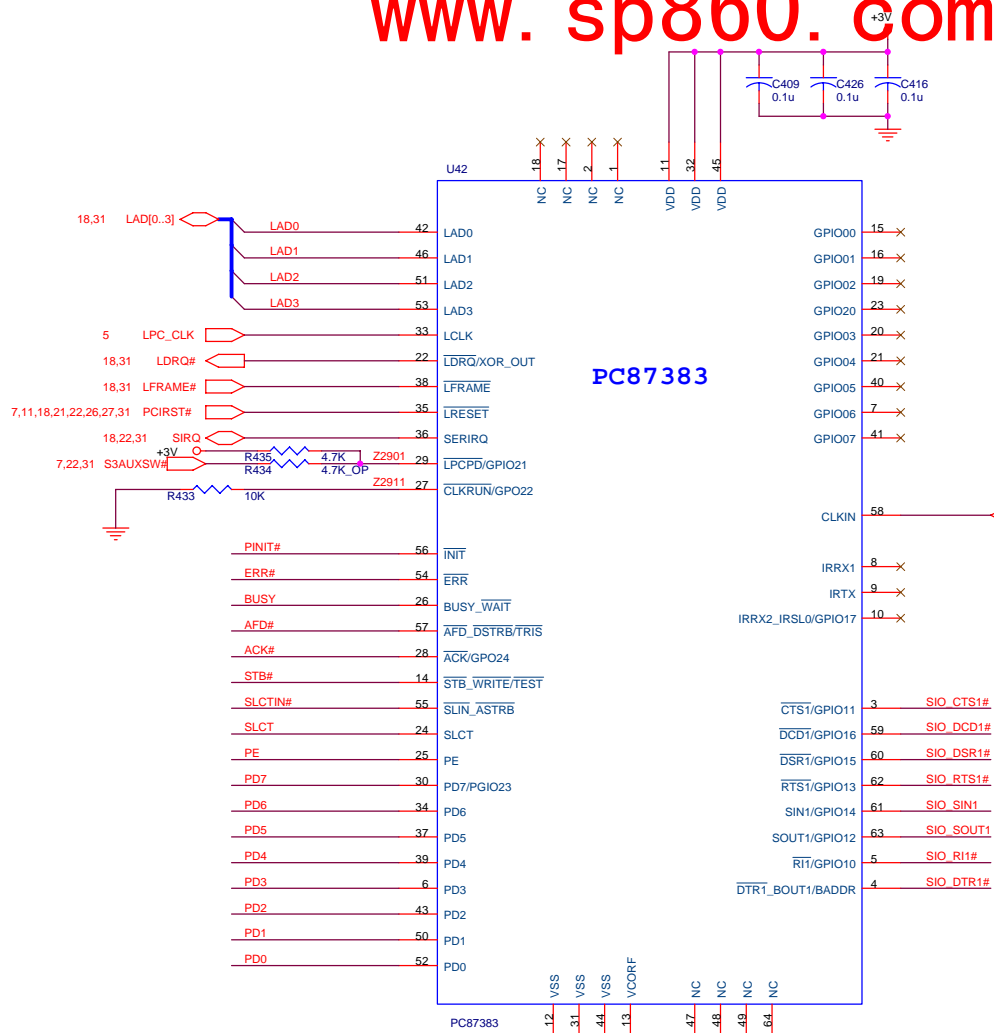

Reserve For Debug Phase

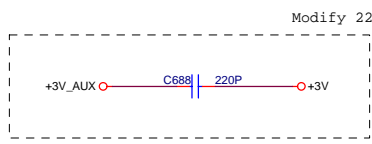
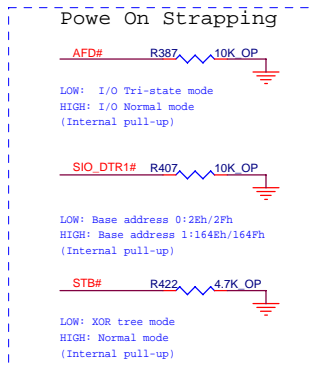
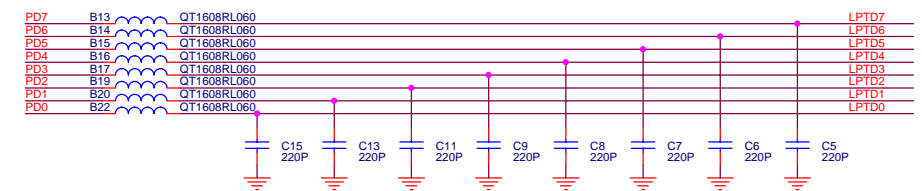
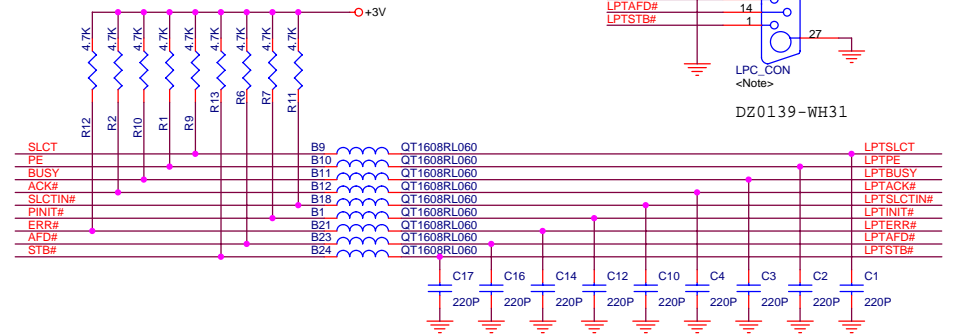
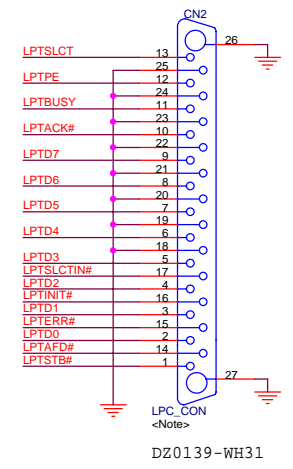

Unwill International Corp.		
Title	755SA1	
Size	Document Number	Rev
	SUPER I/O PC87383	A
Date:	Monday, December 08, 2003	Sheet 29 of 38

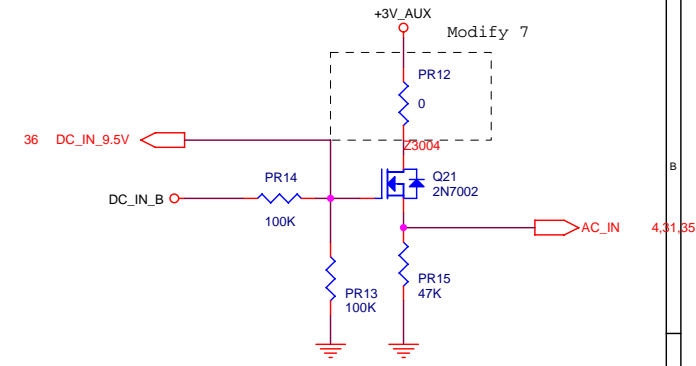
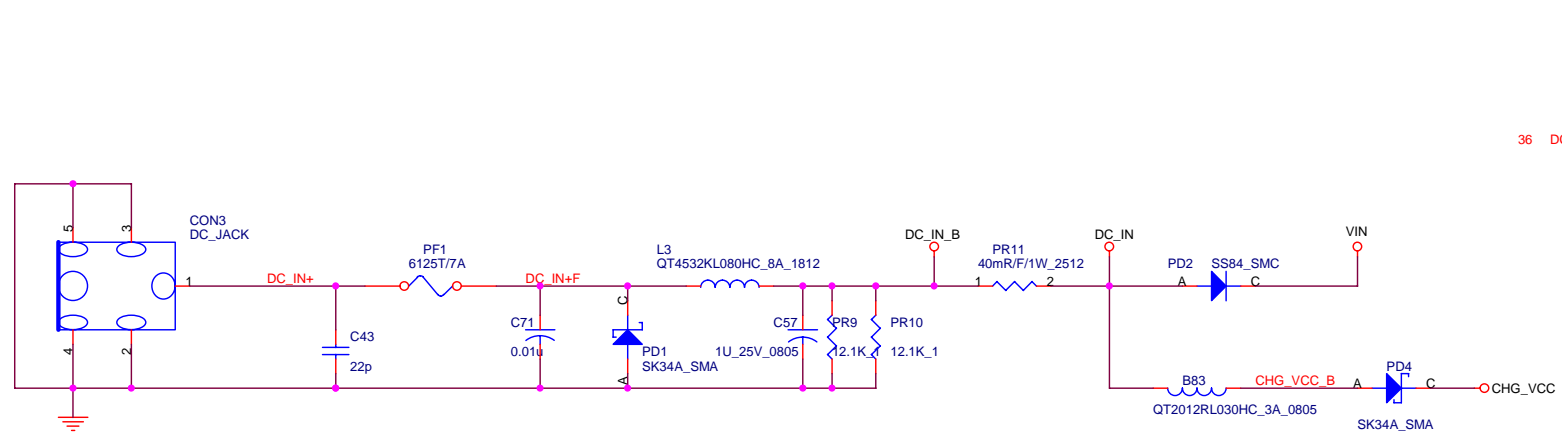
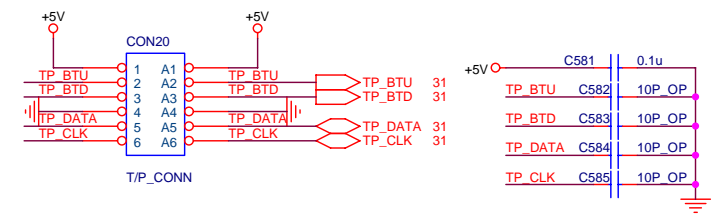
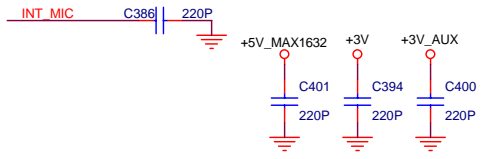
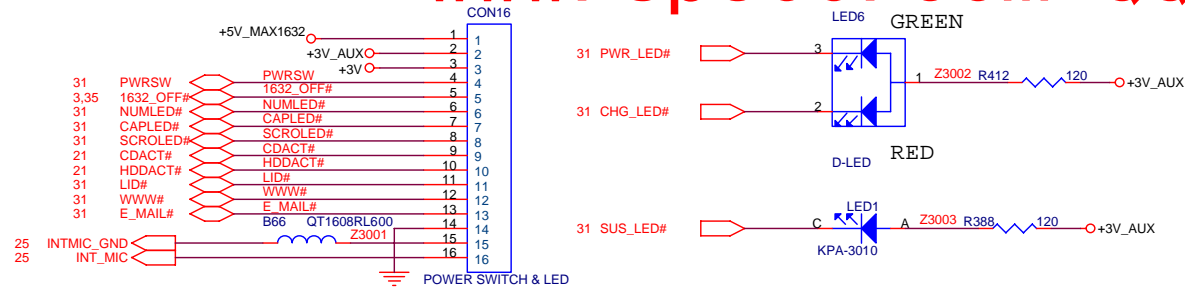

Unwill International Corp.			
Title 755SA1			
Size	Document Number	LED & PS/2 & AC_IN	
	2410	Sheet	30 of 38
Date:	Monday, December 08, 2003	Sheet	30 of 38

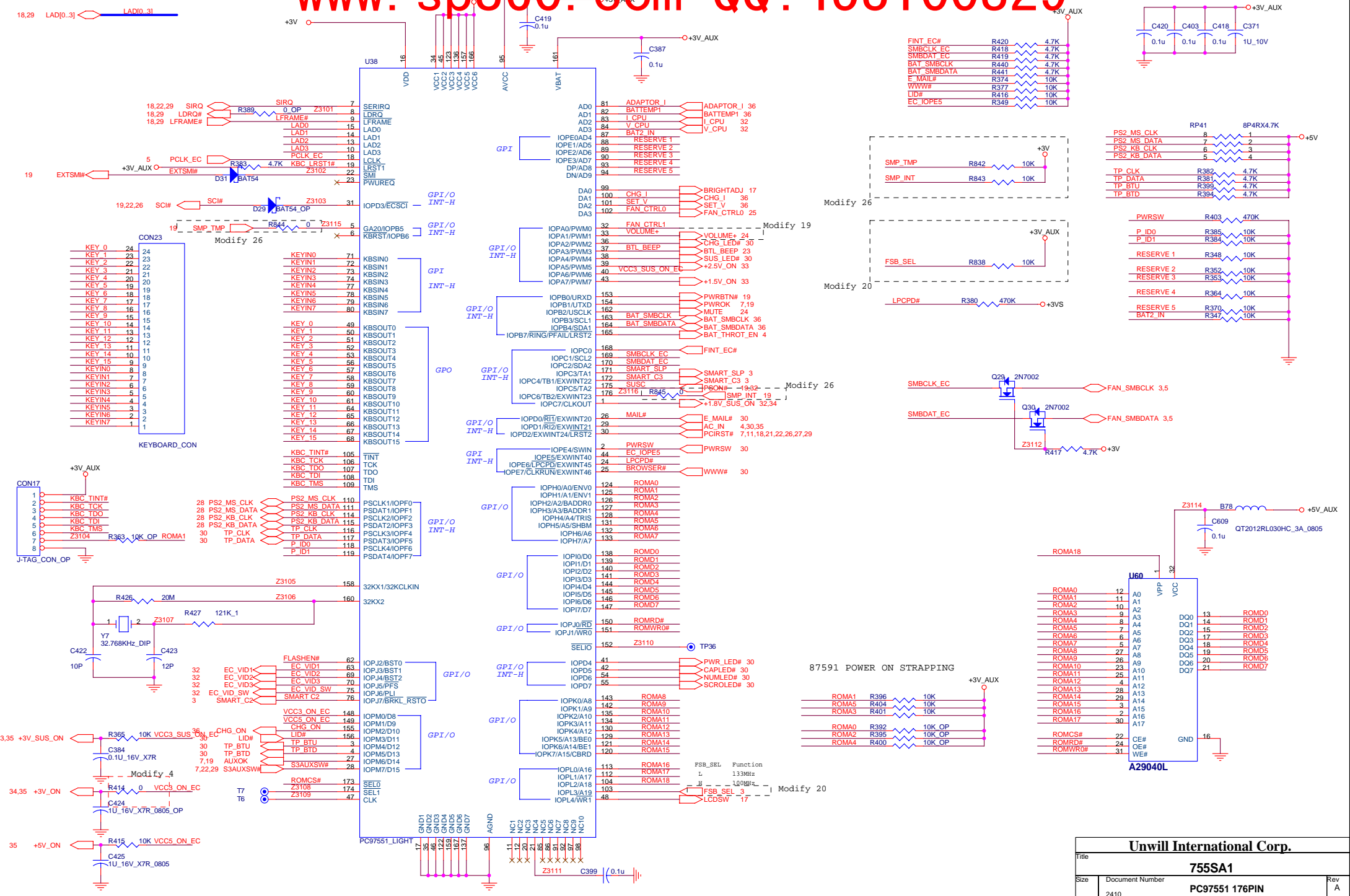

Unwill International Corp.		
755SA1		
Size	Document Number	Rev
2410	PC97551 176PIN	A
Date:	Monday, December 08, 2003	Sheet 31 of 38

$R_{in} = V_{droop}(0.15V) / 0.05mA = 3K \text{ Ohm}$
 $R_{isen} = I(25A) \times R_{ds(ON)}(2.67m \text{ Ohm}) / 0.05mA = 1.33K \text{ Ohm}$
 Channel Freq. = 200KHz for $R_t=150K \text{ Ohm}$

www.sp860.com QQ: 453100829

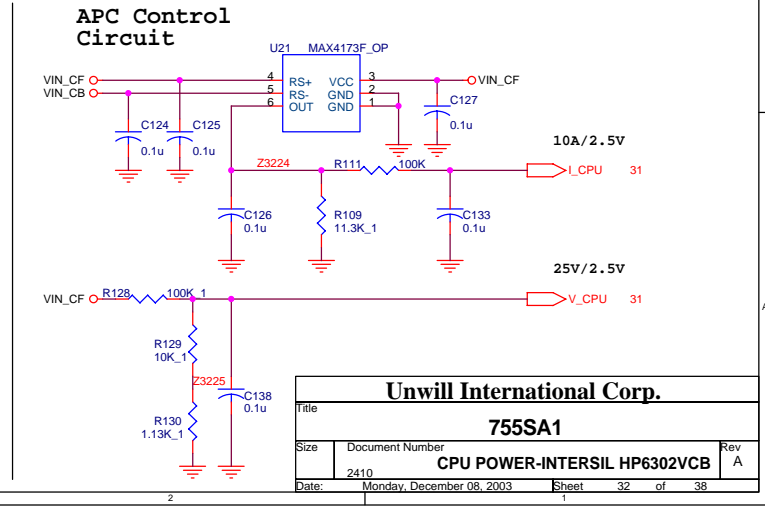
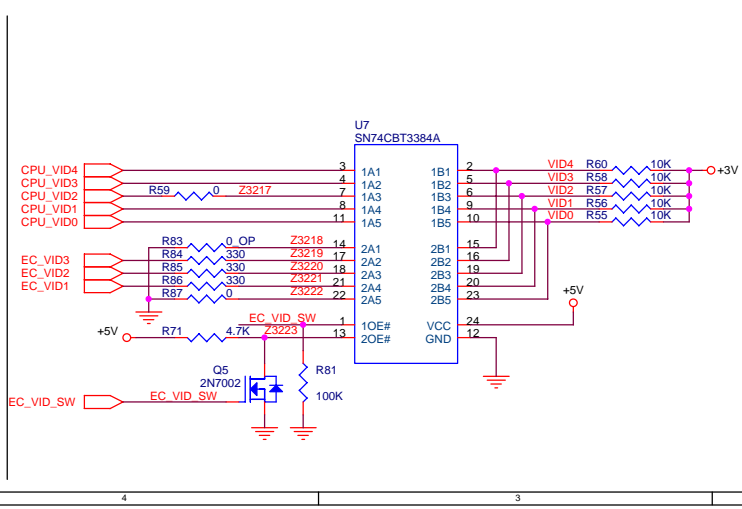
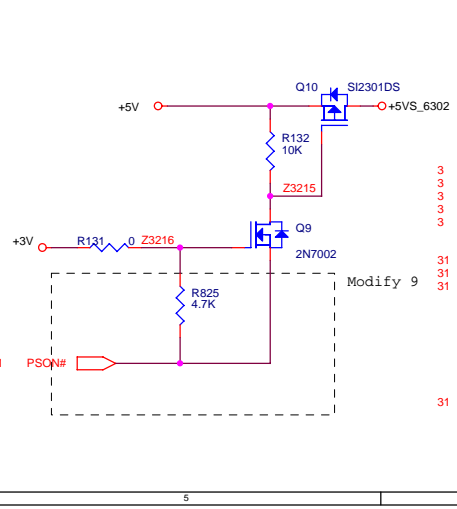
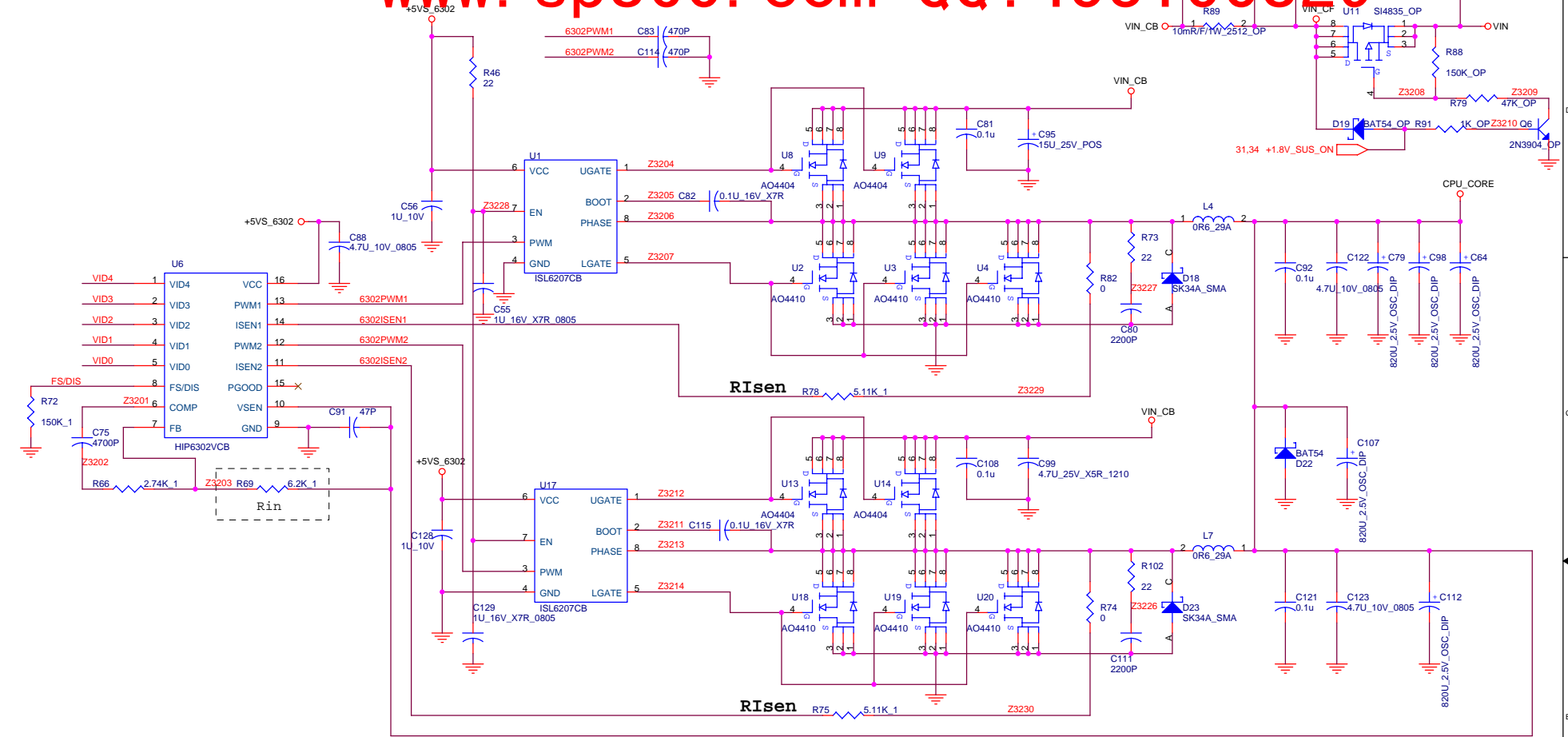

Unwill International Corp.		
755SA1		
Size	Document Number	Rev
2410	CPU POWER-INTERSIL HP6302VCB	A
Date:	Monday, December 08, 2003	Sheet 32 of 38

+2.5VS POWER

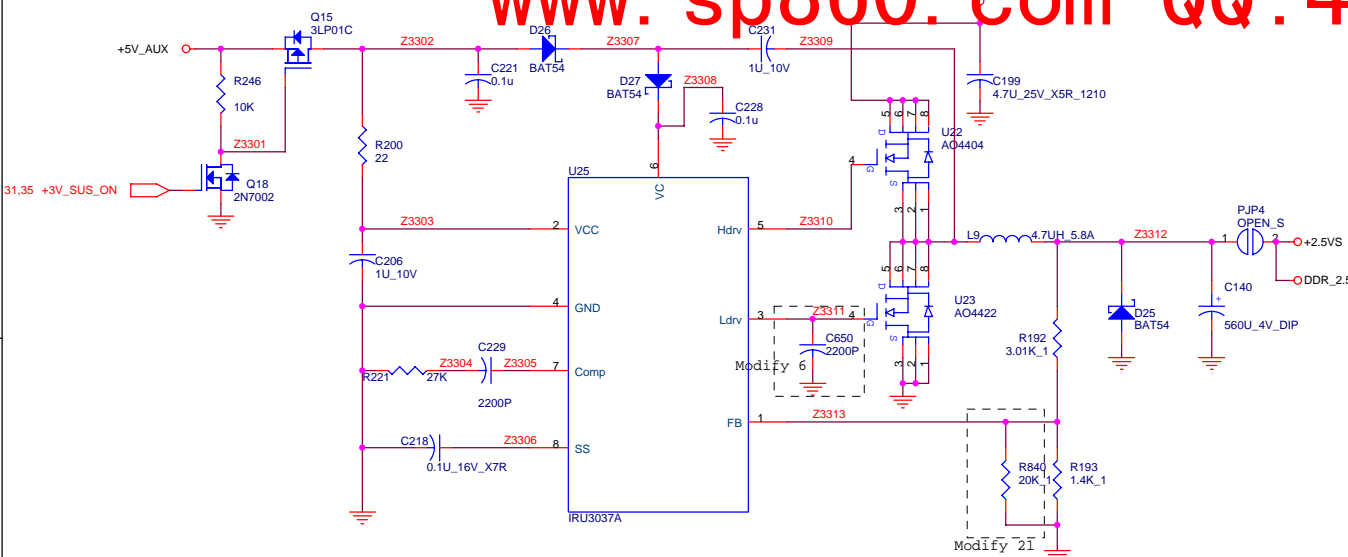

+1.5V POWER

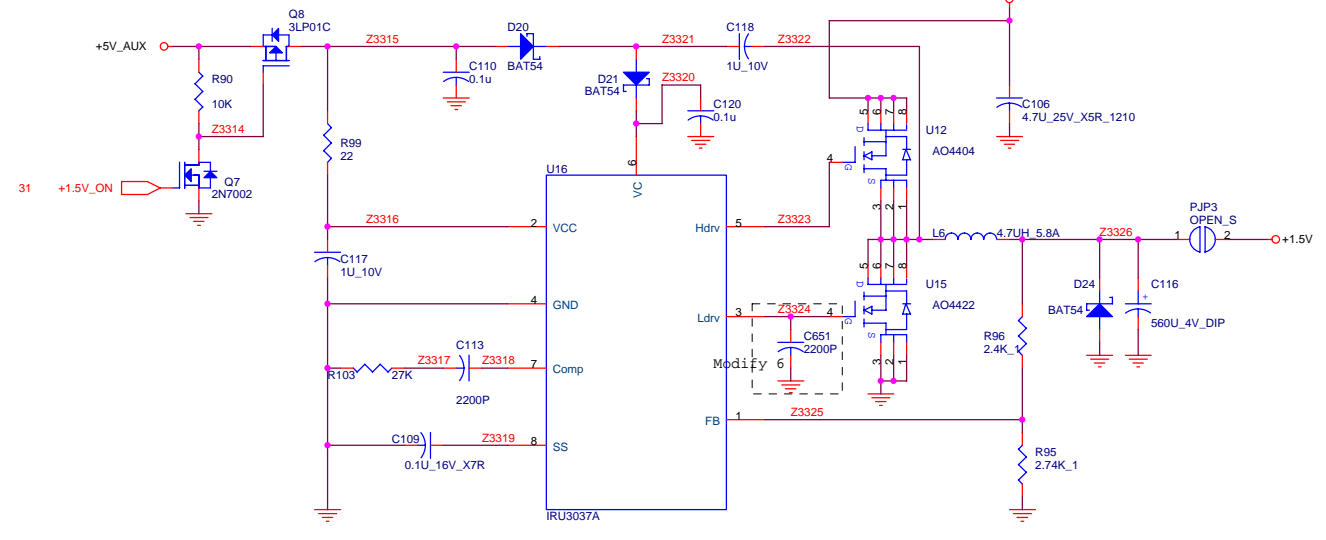

+2.5V POWER

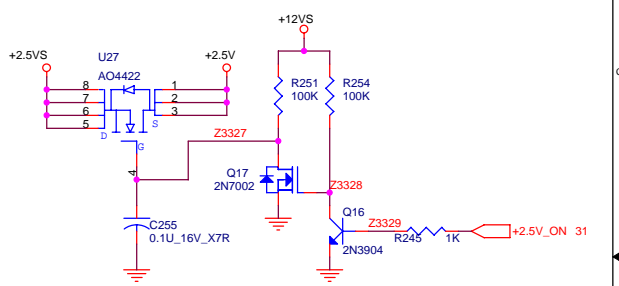

+1.25V POWER

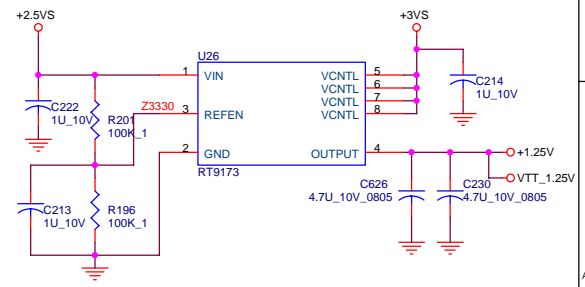

Unwill International Corp.		
Title		
755SA1		
Size	Document Number	Rev
2410	2.5V/1.5V/1.25V	A
Date:	Monday, December 08, 2003	Sheet 33 of 38

+1.8VS POWER

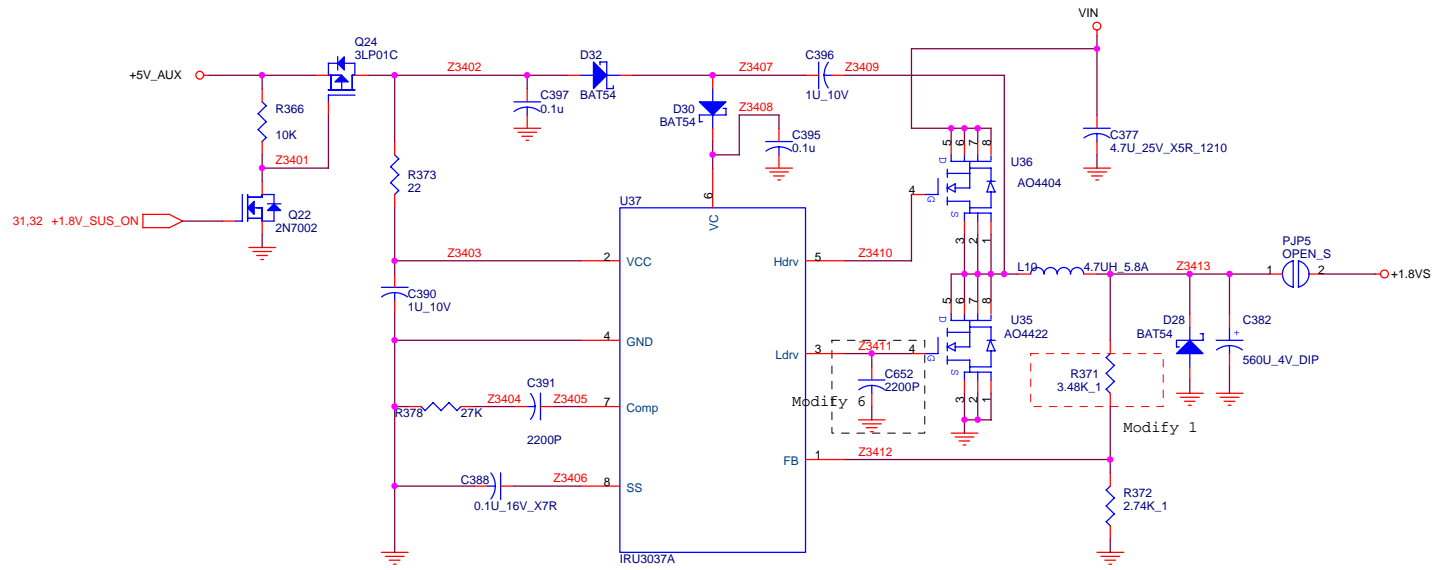

+1.8V POWER

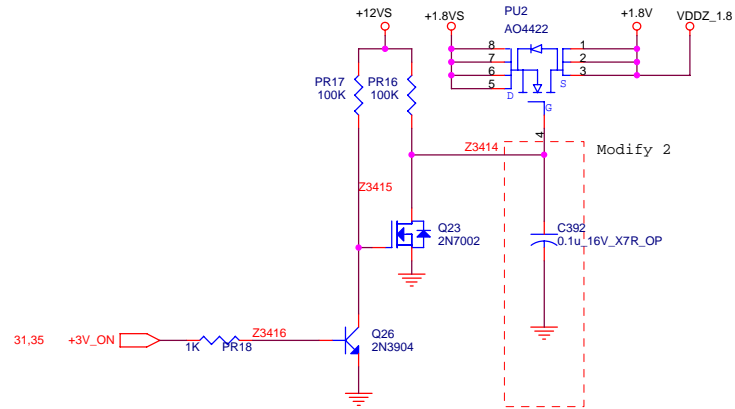

Unwill International Corp.

Title			755SA1
Size	Document Number	1.8V	
	2410	Rev A	
Date:	Monday, December 08, 2003	Sheet	34 of 38

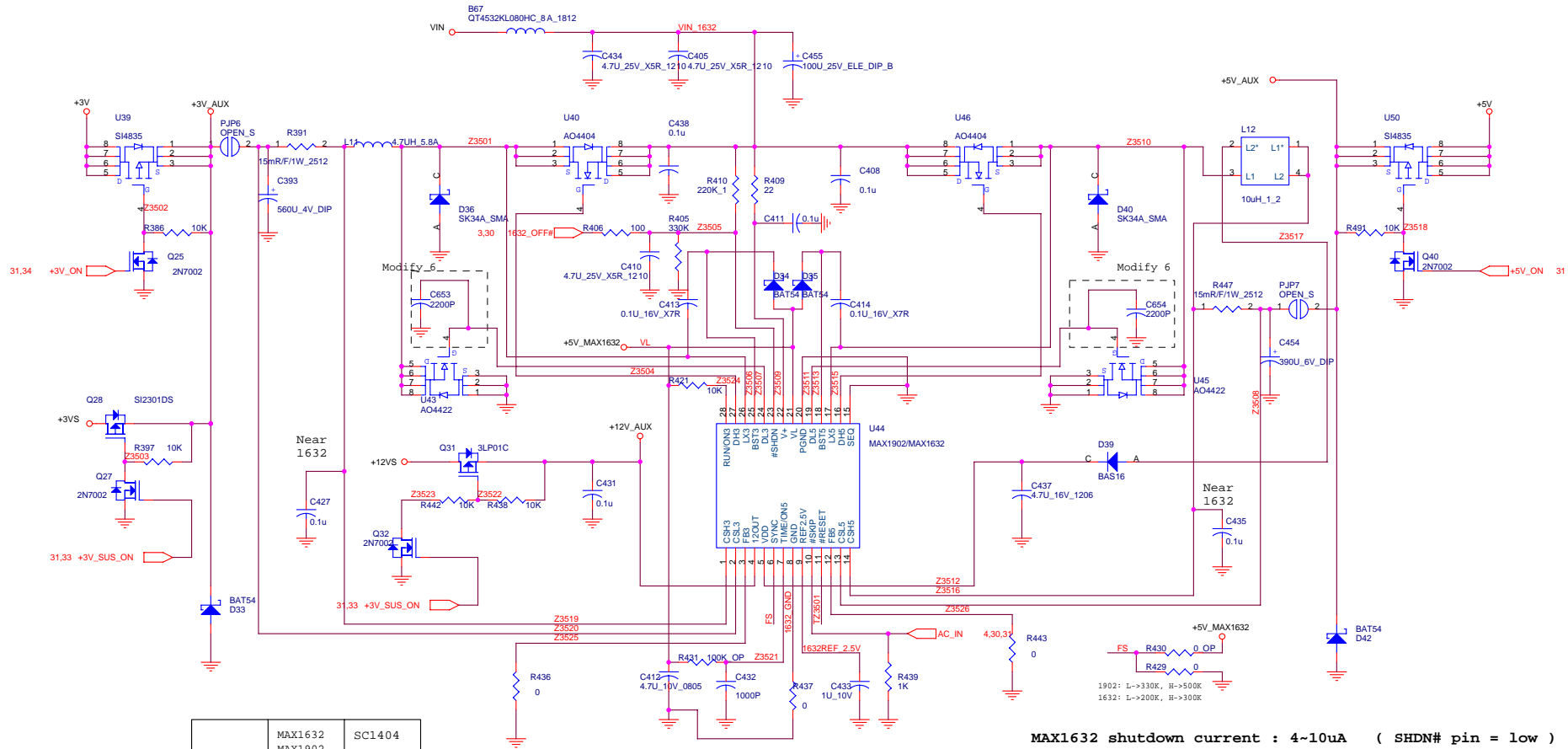

	MAX1632	SC1404
	MAX1902	
R1082	0	100pF
R1083	100K_OP	100K
R1084	0	100pF
R977, R983	15mR, 15mR	8mR, 8mR

MAX1632 shutdown current : 4-10uA (SHDN# pin = low)

MAX1632 standby power : 2.5mW ~ 4mW

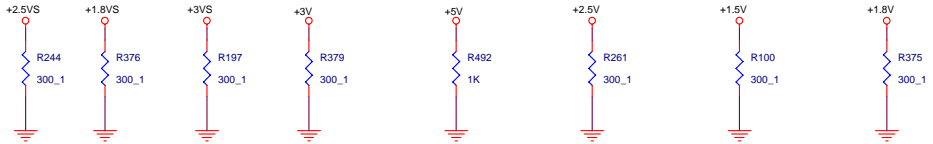

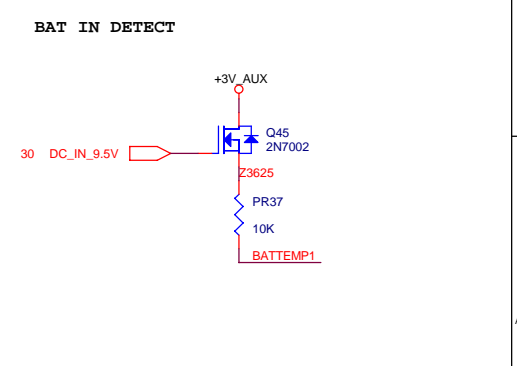
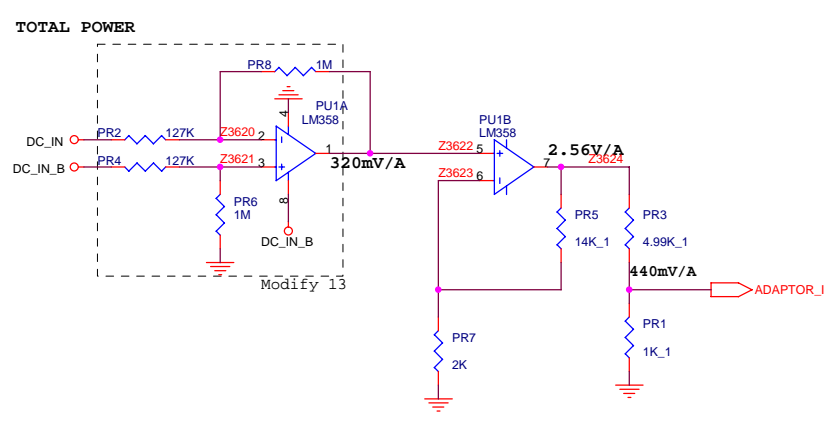
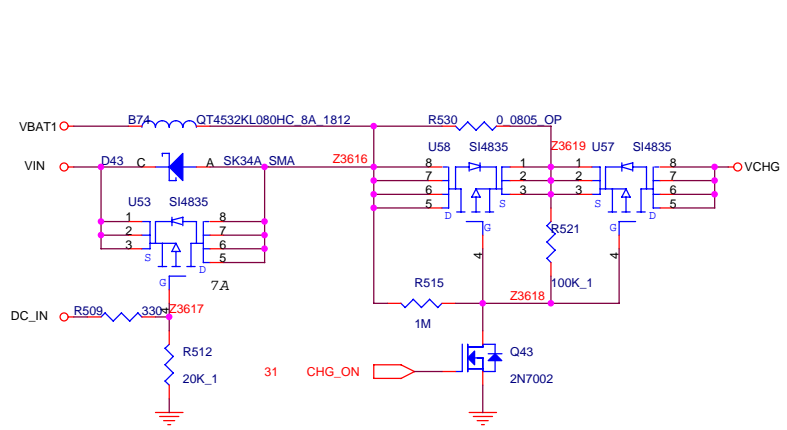
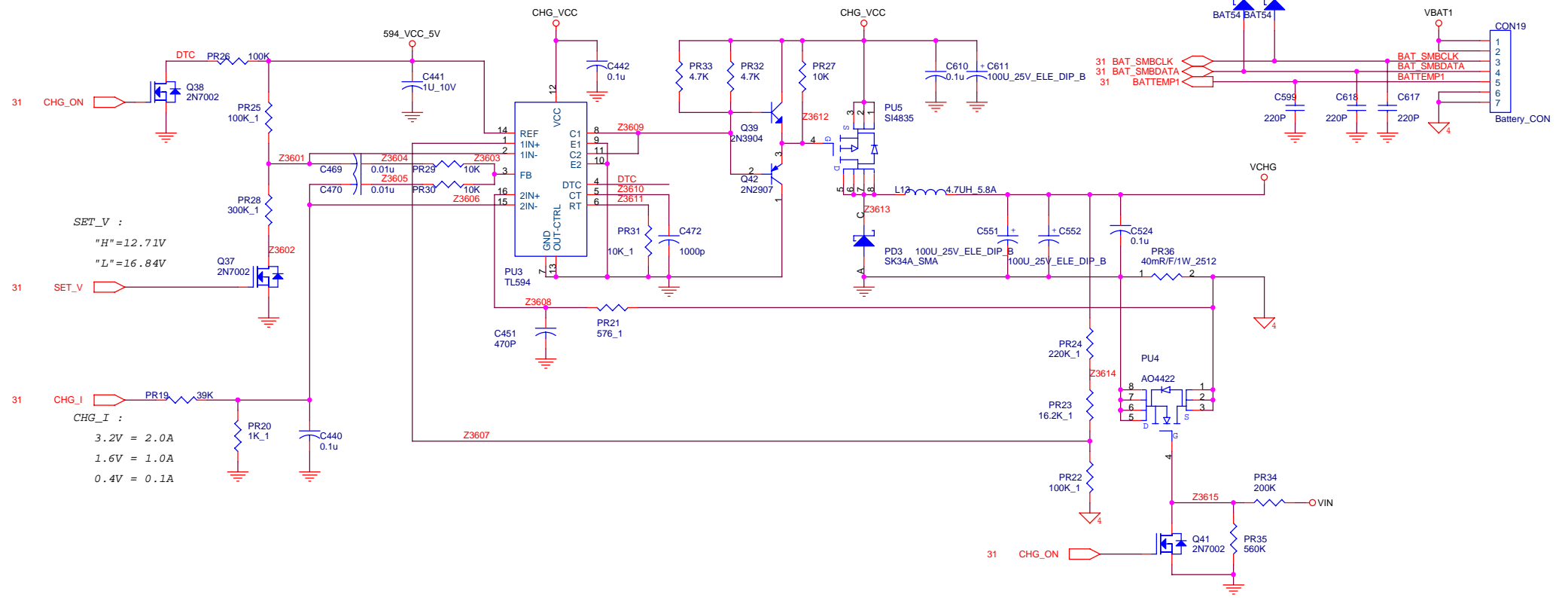

Unwill International Corp.			
755SA1			
Title	Document Number		
Size	2410		Rev A
Date:	Monday, December 08, 2003	Sheet	36 of 38

POWER BLOCK DIAGRAM

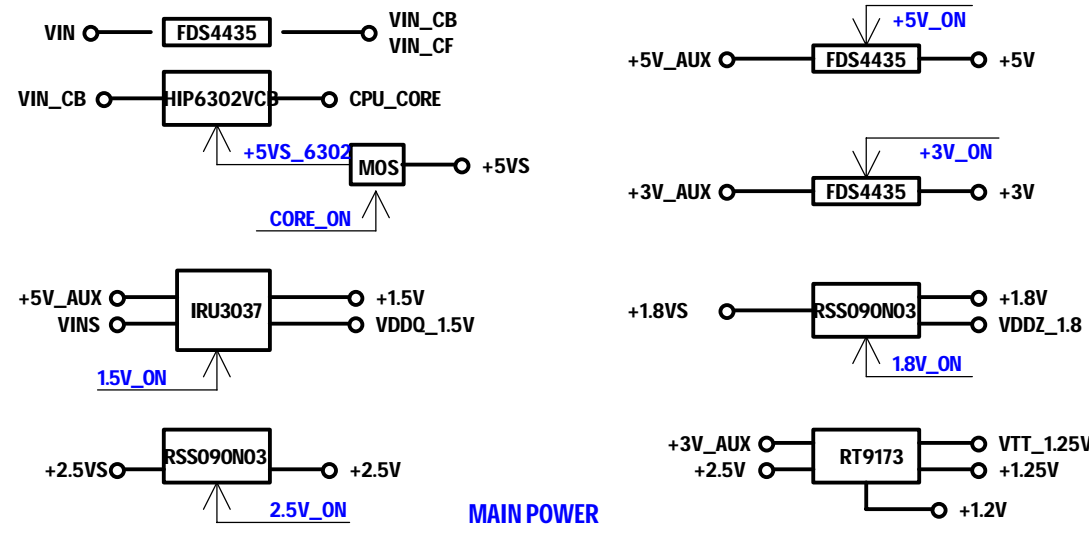
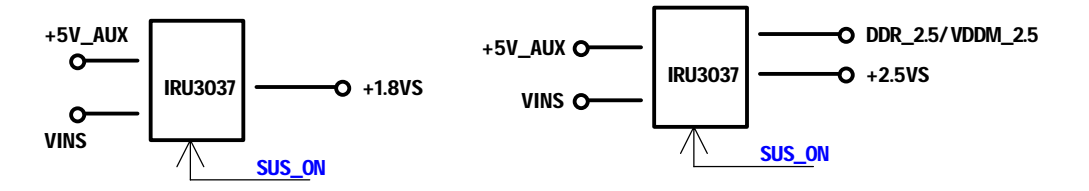
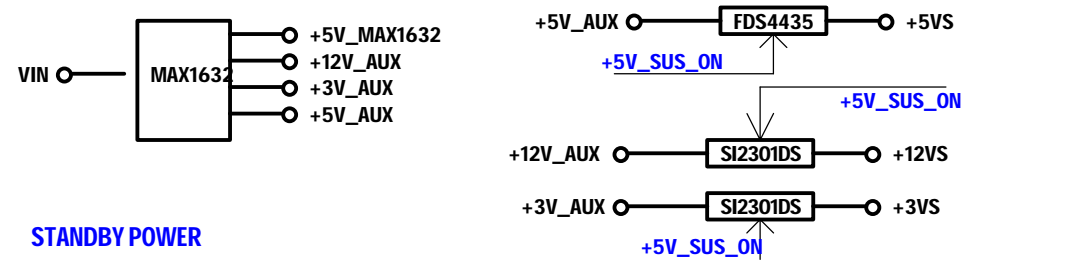
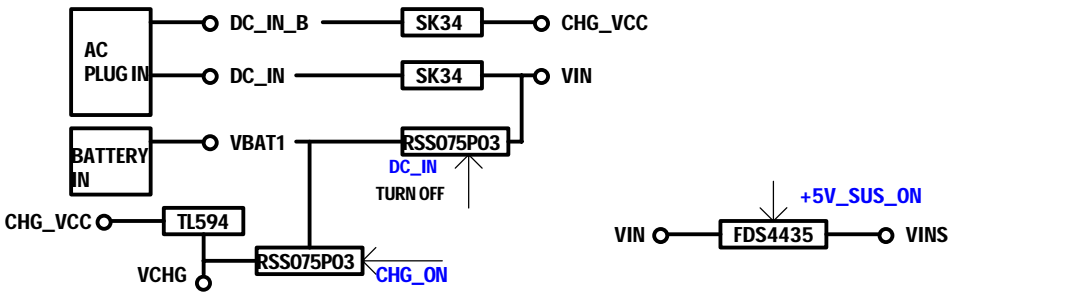

MAIN POWER

POWER ON SEQUENCE

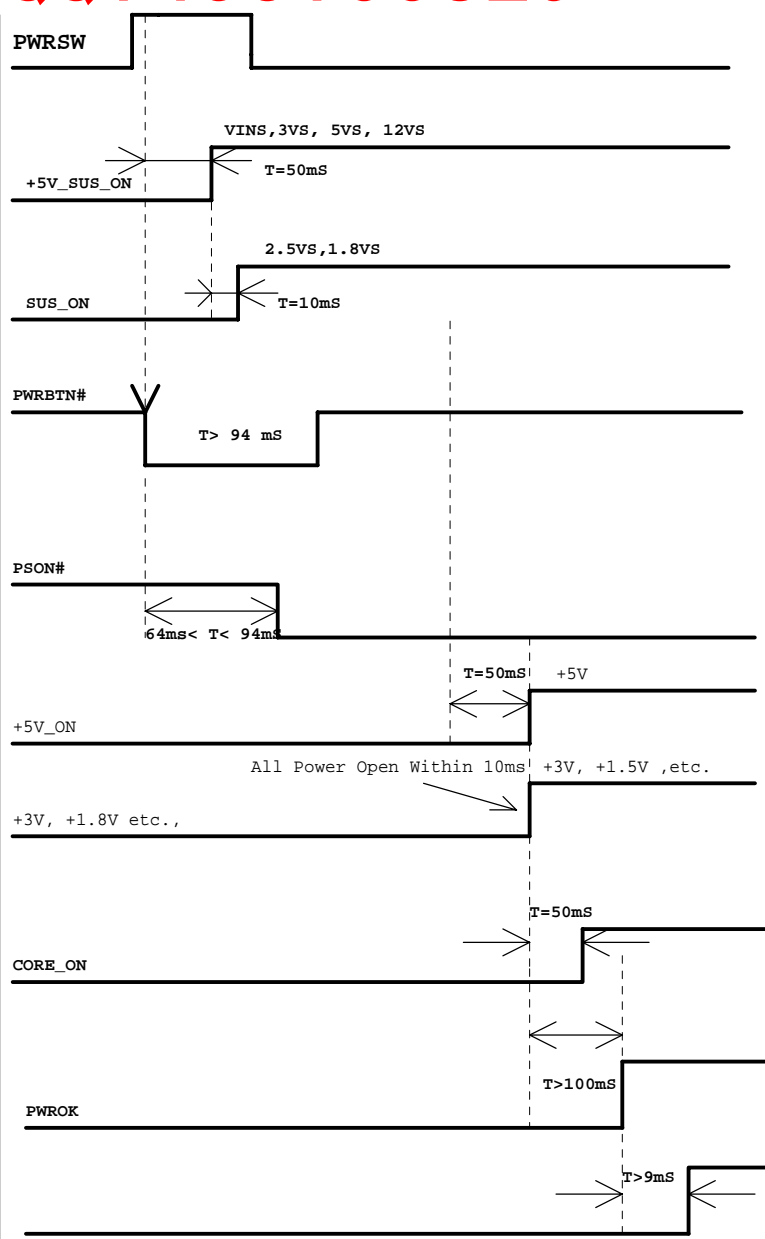

Unwill International Corp.			
Title 755SA1			
Size	Document Number	Rev A	
2410	POWER BLOCK DIAGRAM		
Date:	Monday, December 08, 2003	Sheet	37 of 38

CPU				
	CPU CORE (V)	ICC (mA)	W	TEMP ()
2.0G	1.525	35.7	54.3	69
2.2G	1.525	37.5	57.1	70
2.26G	1.525	38.1	58.0	70
2.4G	1.525	39.3	59.8	71
2.5G	1.525	40	61.0	72
2.53G	1.525	40.4	61.5	72
2.6G	1.525	41.05	62.6	72
2.66G	1.525	43.35	66.1	74
2.8G	1.525	44.86	68.4	75
3.06G	1.525	53.64	81.8	69

SIS648			
VCC	ICC (mA)	W	TEMP ()
+3.3V	108.19	0.357	70
+2.5V	501.3	1.254	
+1.8V	1390	2.502	
+3.3V_AUX	33.4	0.084	
+1.8V_AUX	10	0.018	
CPU CORE	266	0.452	
AGPVDD	35.1	0.053	

SIS660FX			
VCC	ICC (mA)	W	TEMP ()
+3.3V	167.39	0.55	70
+2.5V	587.28	1.468	
+1.8V	278.69	2.502	
+3.3V_AUX	20	0.066	
IVDD_AUX	18	0.027	
CPU CORE	390	0.58	
+1.5V	2060	3.09	

SIS963			
VCC	ICC (mA)	W	TEMP ()
+3.3V	140	0.462	70
+1.8V	580	1.044	
VTT (+1.5V)	30	0.045	
RTCVDD	0.003	0.0099	
+3.3V_AUX	380	1.254	
+1.8V_AUX	70	0.126	

PC87591			
VCC	ICC (mA)	W	TEMP ()
+3.3V	300	1	70

CLOCK GENERATOR			
VCC	ICC (mA)	W	TEMP ()
+3.3V	100	0.33	70

DDR DUFFER			
VCC	ICC (mA)	W	TEMP ()
+2.5V	0.1	0.2m	85

ADM1032			
VCC	ICC (mA)	W	TEMP ()
+3.3V	0.17	0.56m	150

OZ6912			
VCC	ICC (mA)	W	TEMP ()
+3.3V	30	0.1	70

VT1211			
VCC	ICC (mA)	W	TEMP ()
+3.3V	300	1	70

FW802C			
VCC	ICC (mA)	W	TEMP ()
+3.3V	167	0.55	70

RTL8201			
VCC	ICC (mA)	W	TEMP ()
+3.3V	200	0.66	70

VT1612A			
VCC	ICC (mA)	W	TEMP ()
+5V	70	0.35	70

LM4835			
VCC	ICC (mA)	W	TEMP ()
+5V	35	1.5	85

SIS180			
VCC	ICC (mA)	W	TEMP ()
+3V	150	0.45	85
+1.8V	150	0.27	

PCI DEVICE

	IDSEL	REQ	GNT	INT
OZ6912	AD19	PREQ#0	PGNT#0	INTB#
SATA	AD23	PREQ#1	PGNT#1	INTD#

Unwill International Corp.			
Title 755SA1			
Size	Document Number		Rev
2410	POWER CONSUMPTION		A
Date:	Monday, December 08, 2003	Sheet 38 of 38	