

ZZZ1 LA-4761P  
PCB  
DAZ06H00100

# Compal Confidential

## KIU10-Tiger M/B Schematics Document

2009-01-13

REV:1.0

Security Classification	Compal Secret Data		Title	
Issued Date		Deciphered Date	Cover Sheet	
THIS SHEET OF ENGINEERING DRAWING IS THE PROPRIETARY PROPERTY OF COMPAL ELECTRONICS, INC. AND CONTAINS CONFIDENTIAL AND TRADE SECRET INFORMATION. THIS SHEET MAY NOT BE TRANSFERRED FROM THE CUSTODY OF THE COMPETENT DIVISION OF R&D DEPARTMENT EXCEPT AS AUTHORIZED BY COMPAL ELECTRONICS, INC. NEITHER THIS SHEET NOR THE INFORMATION IT CONTAINS MAY BE USED BY OR DISCLOSED TO ANY THIRD PARTY WITHOUT PRIOR WRITTEN CONSENT OF COMPAL ELECTRONICS, INC.			Size Custom	Document Number
			Date:	KIU10 LA-4761P
			Rev	1.0
			Sheet	1 of 22

# Compal Confidential

Model Name : Kxxxxx

## Tiger System-Board

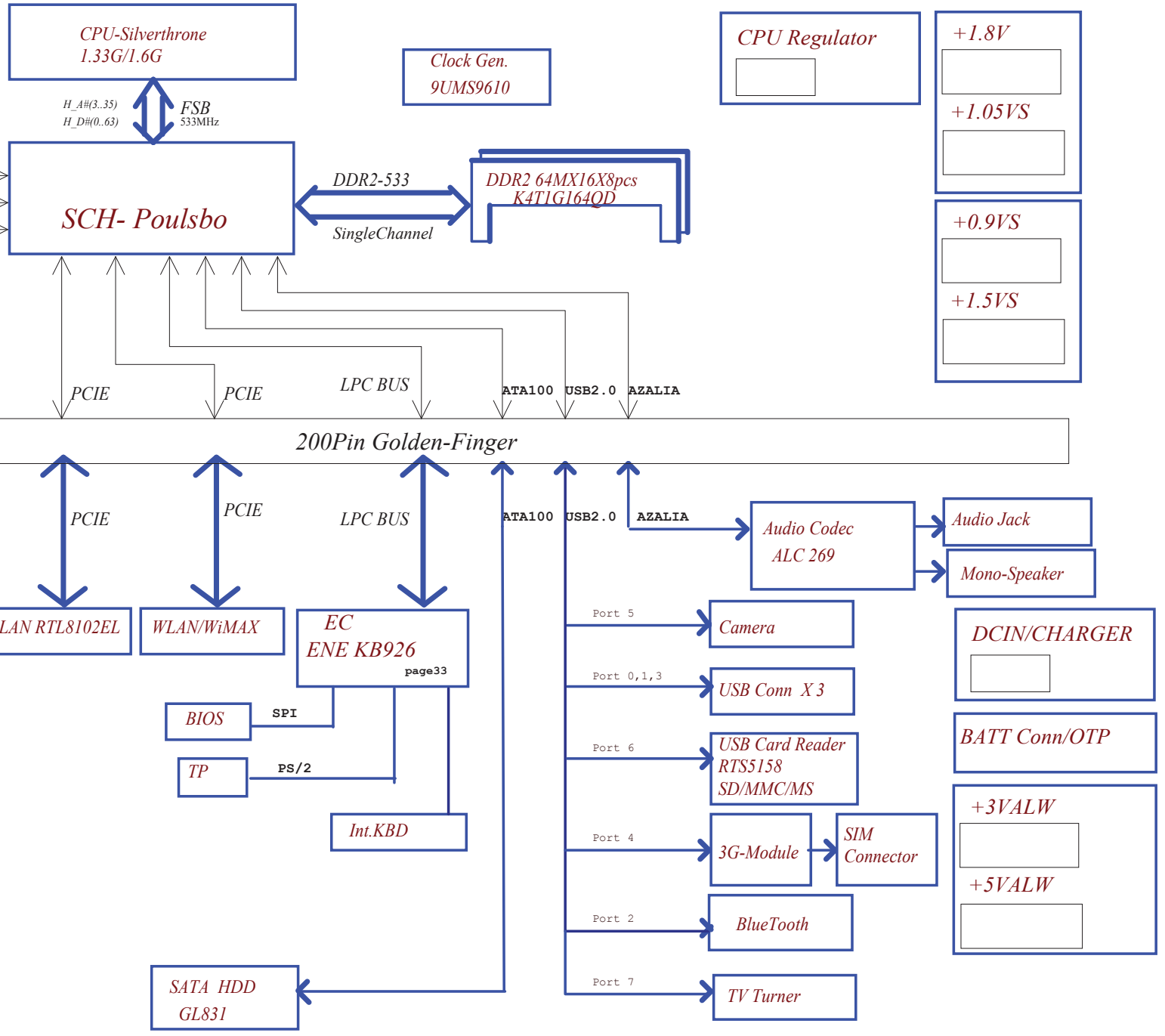

File Name: Tiger Main-Board

<http://hobi-elektronika.net>

Security Classification	Compal Secret Data			Compal Electronics, Inc.		
Issued Date		Deciphered Date		Title		
THIS SHEET OF ENGINEERING DRAWING IS THE PROPRIETARY PROPERTY OF COMPAL ELECTRONICS, INC. AND CONTAINS CONFIDENTIAL AND TRADE SECRET INFORMATION. THIS SHEET MAY NOT BE TRANSFERRED FROM THE CUSTODY OF THE COMPETENT DIVISION OF R&D DEPARTMENT EXCEPT AS AUTHORIZED BY COMPAL ELECTRONICS, INC. NEITHER THIS SHEET NOR THE INFORMATION IT CONTAINS MAY BE USED BY OR DISCLOSED TO ANY THIRD PARTY WITHOUT PRIOR WRITTEN CONSENT OF COMPAL ELECTRONICS, INC.				Size	Document Number	Rev
				Custom	KIU10 LA-4761P	1.0
				Date:	Tuesday, January 13, 2009	Sheet 2 of 22

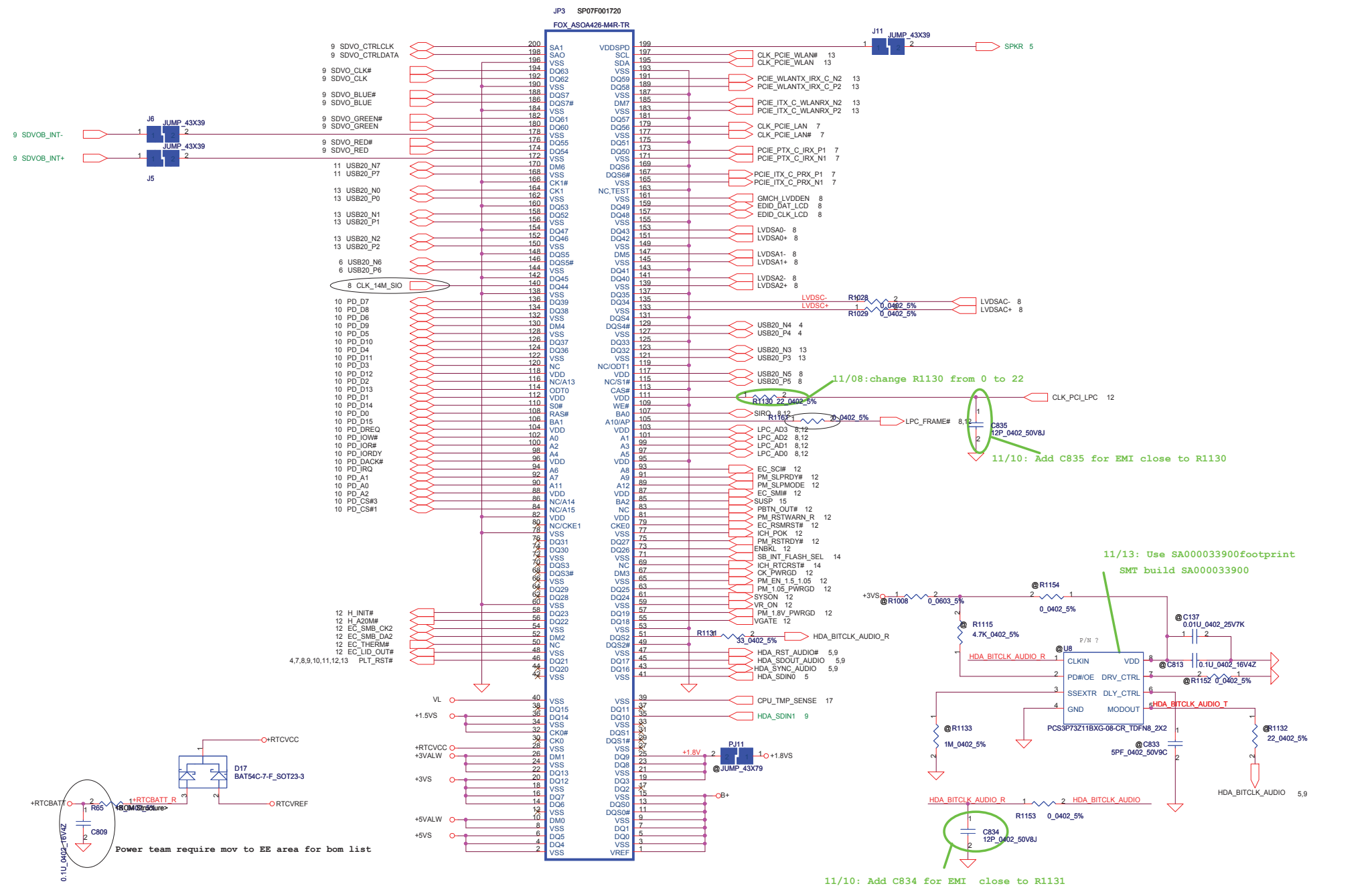

<http://hobi-elektronika.net>

Security Classification		Compal Secret Data		Title		
Issued Date		Deciphered Date		HDI-Interface		
THIS SHEET OF ENGINEERING DRAWING IS THE PROPRIETARY PROPERTY OF COMPAL ELECTRONICS, INC. AND CONTAINS CONFIDENTIAL AND TRADE SECRET INFORMATION. THIS SHEET MAY NOT BE TRANSFERRED FROM THE CUSTODY OF THE COMPETENT DIVISION OF R&D DEPARTMENT EXCEPT AS AUTHORIZED BY COMPAL ELECTRONICS, INC. NEITHER THIS SHEET NOR THE INFORMATION IT CONTAINS MAY BE USED BY OR DISCLOSED TO ANY THIRD PARTY WITHOUT PRIOR WRITTEN CONSENT OF COMPAL ELECTRONICS, INC.				Size Custom	Document Number <b>KIU10 LA-4761P</b>	Rev 1.0
Date:	Tuesday, January 13, 2009	Sheet	3	of	22	

**FULL LED**

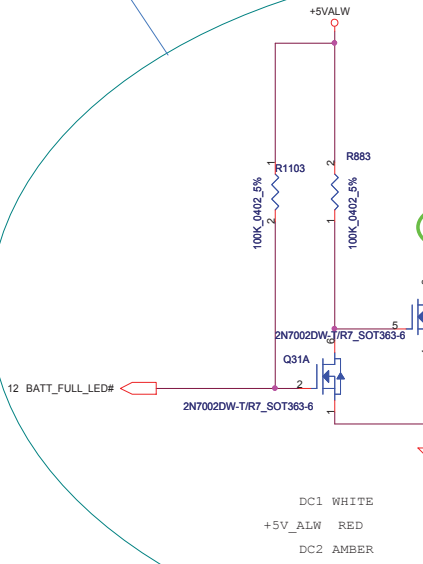

**BATT CHARGE**

11/07:change R573 from 120 to 470  
12/15:change R573 from 470 to 820

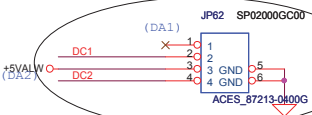
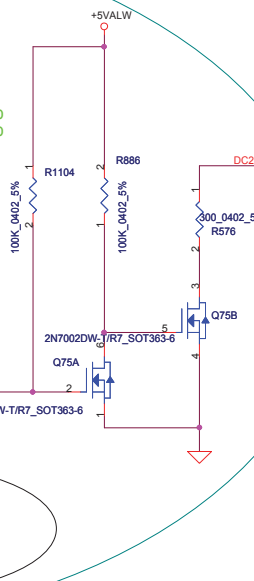
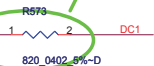

**HeadPhone JACK**

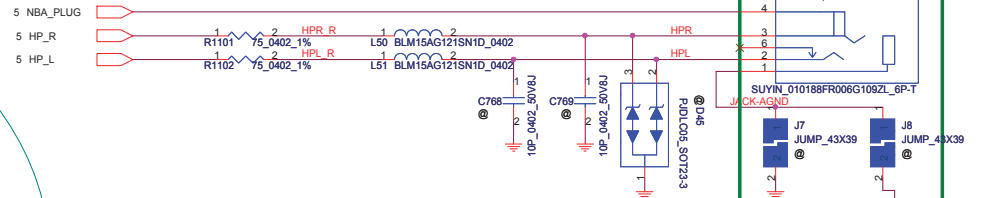

**Ext.MIC JACK**

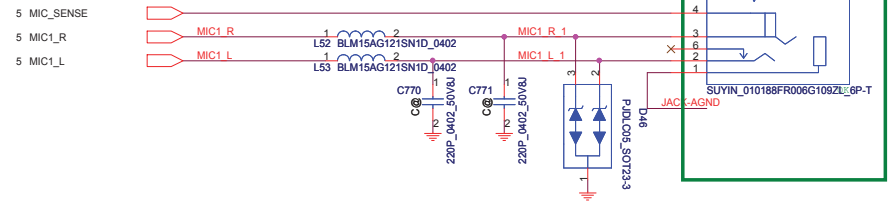

**PCIe Mini Card for 3G**

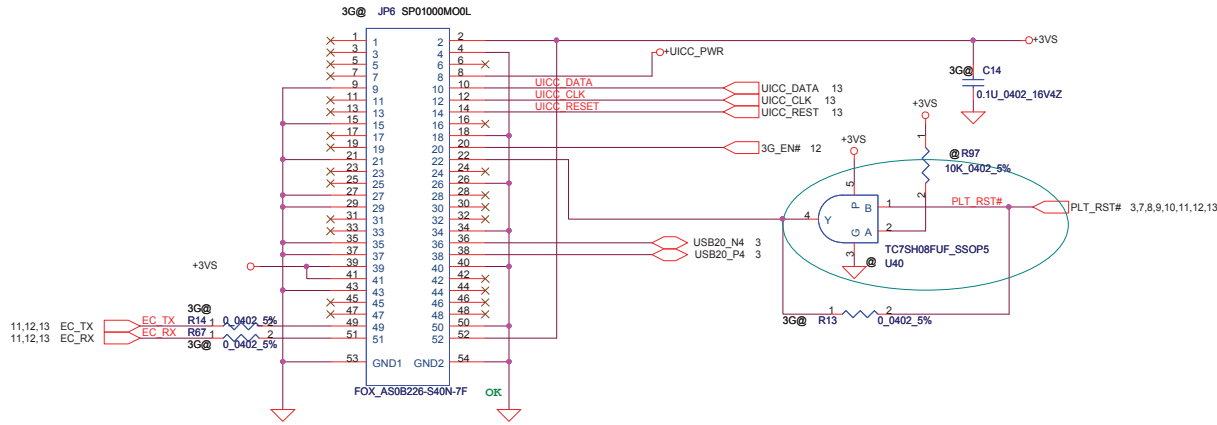

Security Classification	Compal Secret Data		Title	
Issued Date		Deciphered Date	3G/Audio Conn & LED	
THIS SHEET OF ENGINEERING DRAWING IS THE PROPRIETARY PROPERTY OF COMPAL ELECTRONICS, INC. AND CONTAINS CONFIDENTIAL AND TRADE SECRET INFORMATION. THIS SHEET MAY NOT BE TRANSFERRED FROM THE CUSTODY OF THE COMPETENT DIVISION OF R&D DEPARTMENT EXCEPT AS AUTHORIZED BY COMPAL ELECTRONICS, INC. NEITHER THIS SHEET NOR THE INFORMATION IT CONTAINS MAY BE USED BY OR DISCLOSED TO ANY THIRD PARTY WITHOUT PRIOR WRITTEN CONSENT OF COMPAL ELECTRONICS, INC.			Document Number	Rev
			KIU10 LA-4761P	1.0
			Date: Tuesday, January 13, 2009	Sheet 4 of 22

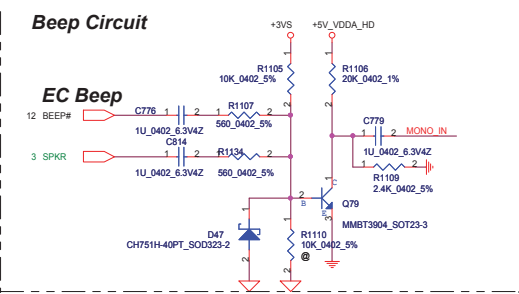
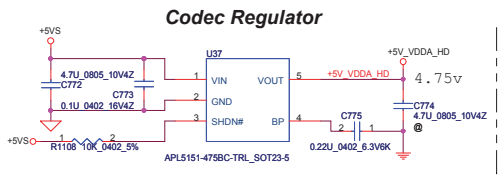

**INT MIC**

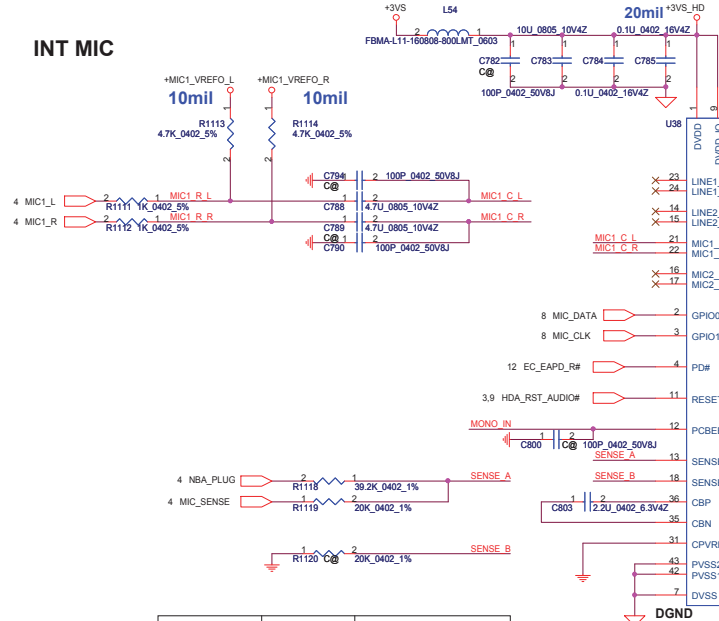

**Left Main Speaker Connector**

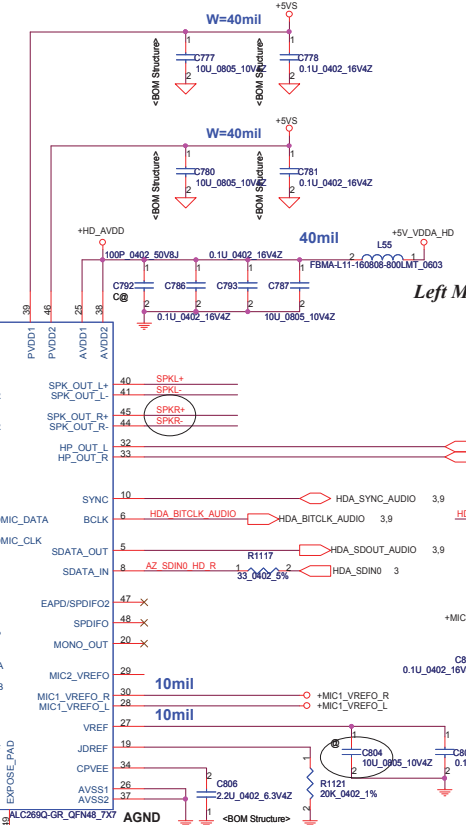

**Speaker Conn.**

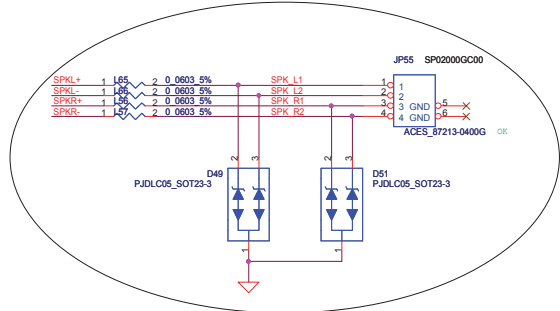

Sense Pin	Impedance	Codec Signals
SENSE A	39.2K	PORT-A (PIN 32, 33)
	20K	PORT-B (PIN 21, 22)
	10K	PORT-C (PIN 23, 24)
SENSE B	5.1K	PORT-D (PIN 48)
	39.2K	PORT-E (PIN 14, 15)
	20K	PORT-F (PIN 16, 17)
	10K	PORT-G (PIN 20)
	5.1K	PORT-H (PIN 47)

**DGND To AGND Bypass**

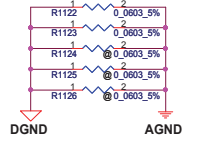

# 3 in 1 Card Reader

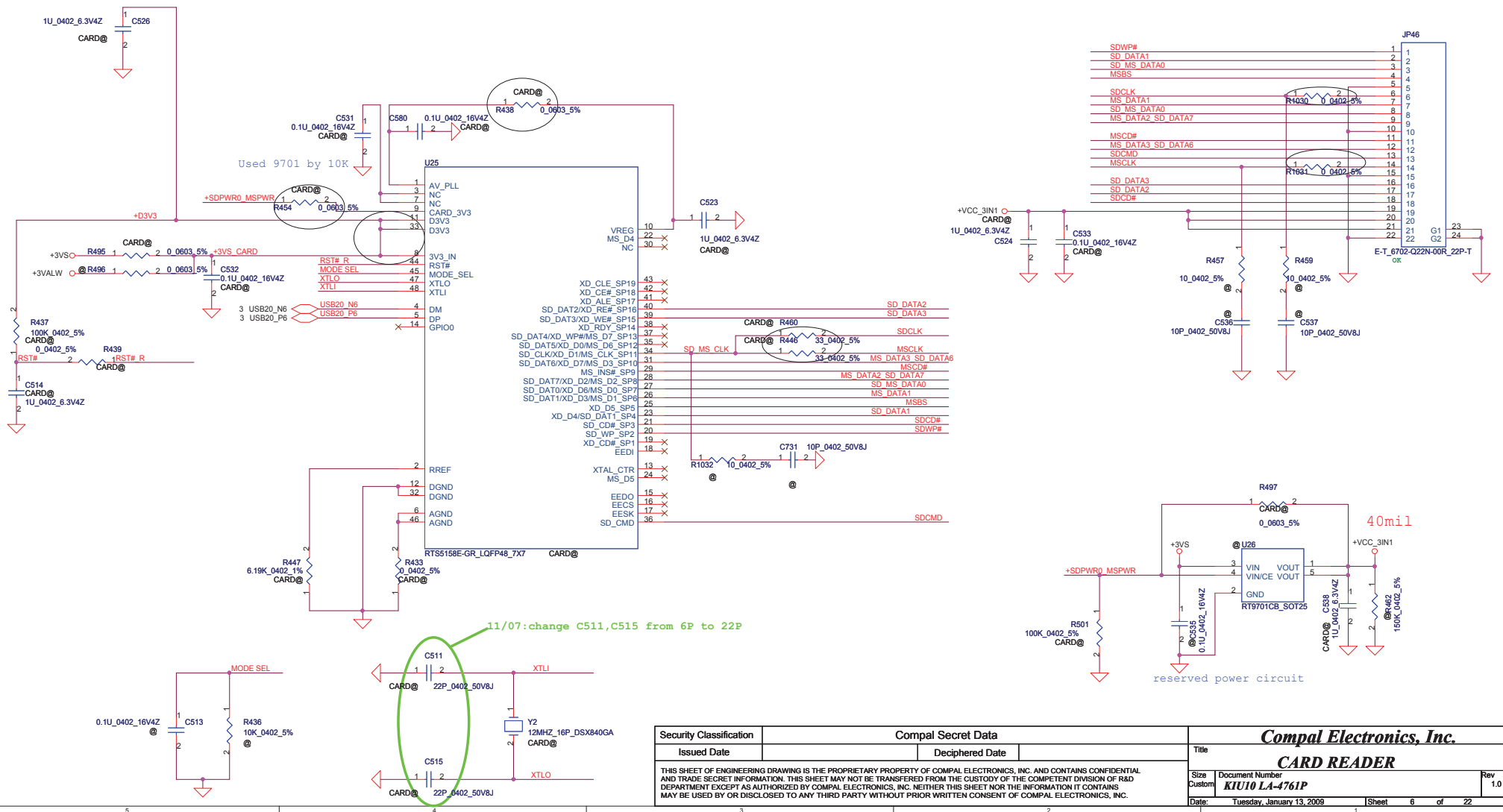

Security Classification		Compal Secret Data		Title <b>Compal Electronics, Inc.</b> <b>CARD READER</b>	
Issued Date		Deciphered Date			
THIS SHEET OF ENGINEERING DRAWING IS THE PROPRIETARY PROPERTY OF COMPAL ELECTRONICS, INC. AND CONTAINS CONFIDENTIAL AND TRADE SECRET INFORMATION. THIS SHEET MAY NOT BE TRANSFERRED FROM THE CUSTODY OF THE COMPETENT DIVISION OF R&D DEPARTMENT EXCEPT AS AUTHORIZED BY COMPAL ELECTRONICS, INC. NEITHER THIS SHEET NOR THE INFORMATION IT CONTAINS MAY BE USED BY OR DISCLOSED TO ANY THIRD PARTY WITHOUT PRIOR WRITTEN CONSENT OF COMPAL ELECTRONICS, INC.				Size Custom	Document Number <b>KIU10 LA-4761P</b>
Date: Tuesday, January 13, 2009				Rev 1.0	Sheet 6 of 22

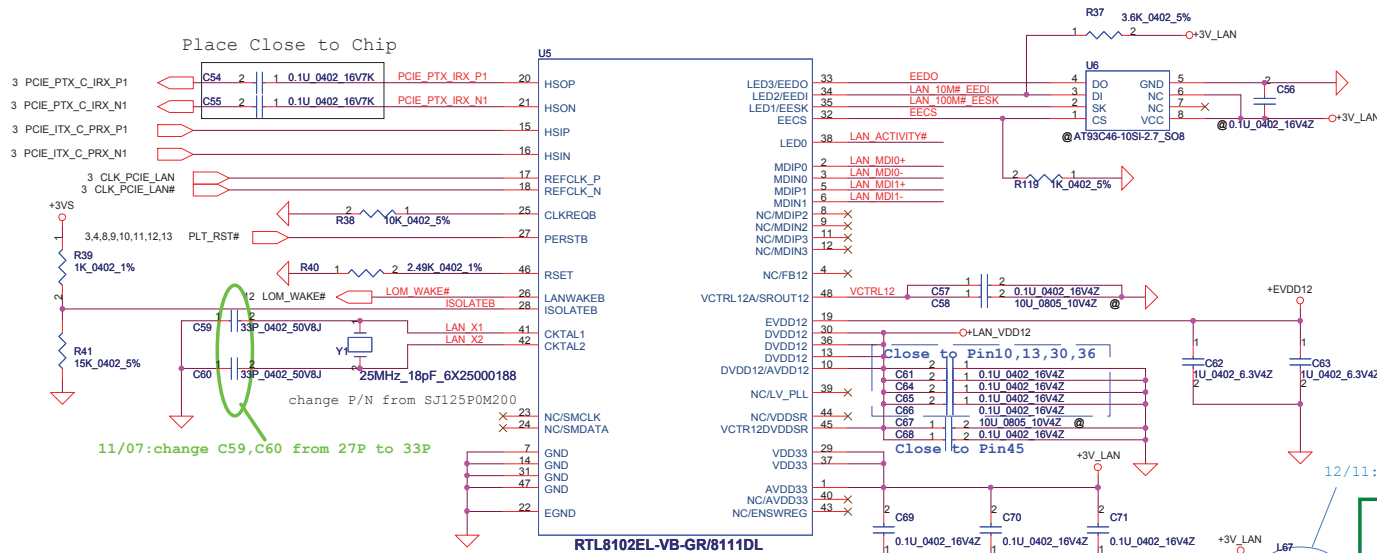

Change the PCB Footprint from Y\_KDS\_1BX25000CK1A\_2P to Y\_6X25000017\_2P

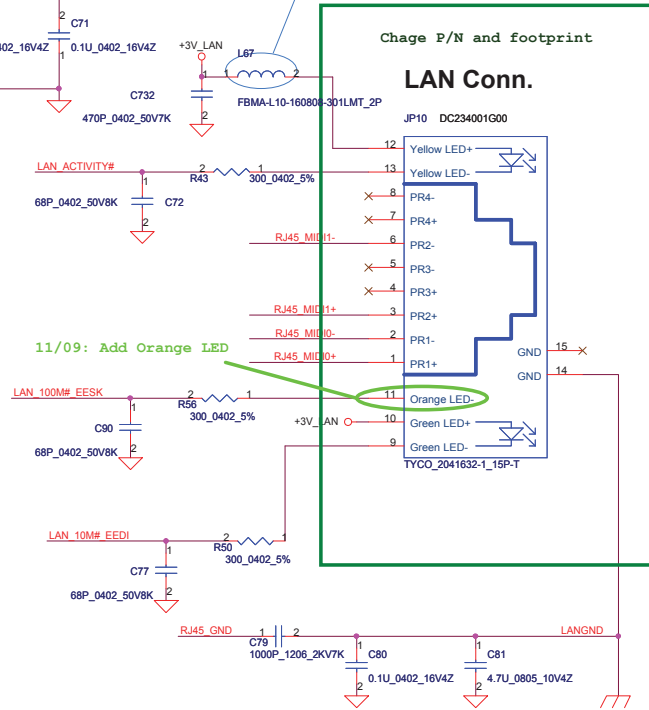
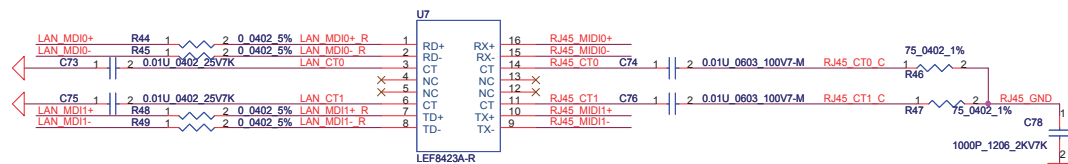

Security Classification		Compal Secret Data		Title	
Issued Date		Deciphered Date		LAN-RTL8102EL	
THIS SHEET OF ENGINEERING DRAWING IS THE PROPRIETARY PROPERTY OF COMPAL ELECTRONICS, INC. AND CONTAINS CONFIDENTIAL AND TRADE SECRET INFORMATION. THIS SHEET MAY NOT BE TRANSFERRED FROM THE CUSTODY OF THE COMPETENT DIVISION OF R&D DEPARTMENT EXCEPT AS AUTHORIZED BY COMPAL ELECTRONICS, INC. NEITHER THIS SHEET NOR THE INFORMATION IT CONTAINS MAY BE USED BY OR DISCLOSED TO ANY THIRD PARTY WITHOUT PRIOR WRITTEN CONSENT OF COMPAL ELECTRONICS, INC.				Size Custom	Document Number KIU10 LA-4761P
Date: Tuesday, January 13, 2009	Sheet 7	of 22	Rev 1.0		

**LCD POWER CIRCUIT**

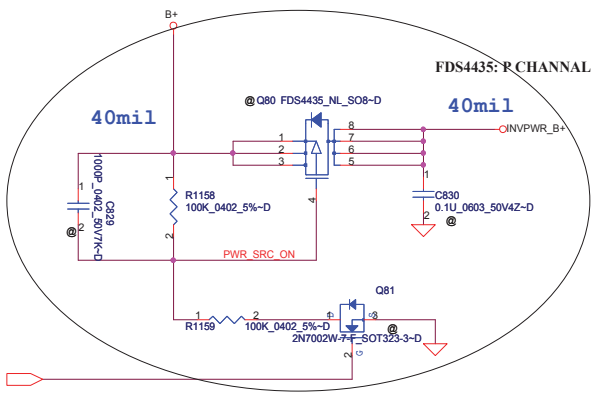
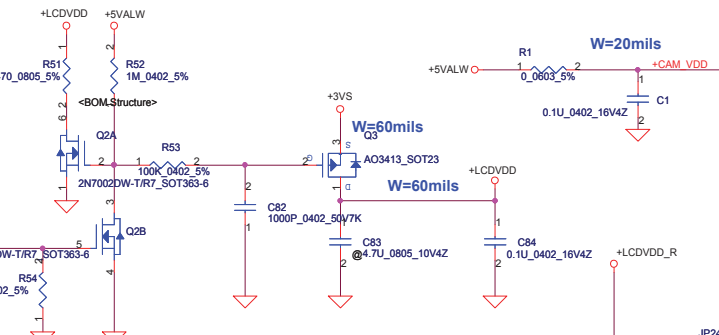

**LCD/PANEL BD. Conn.**

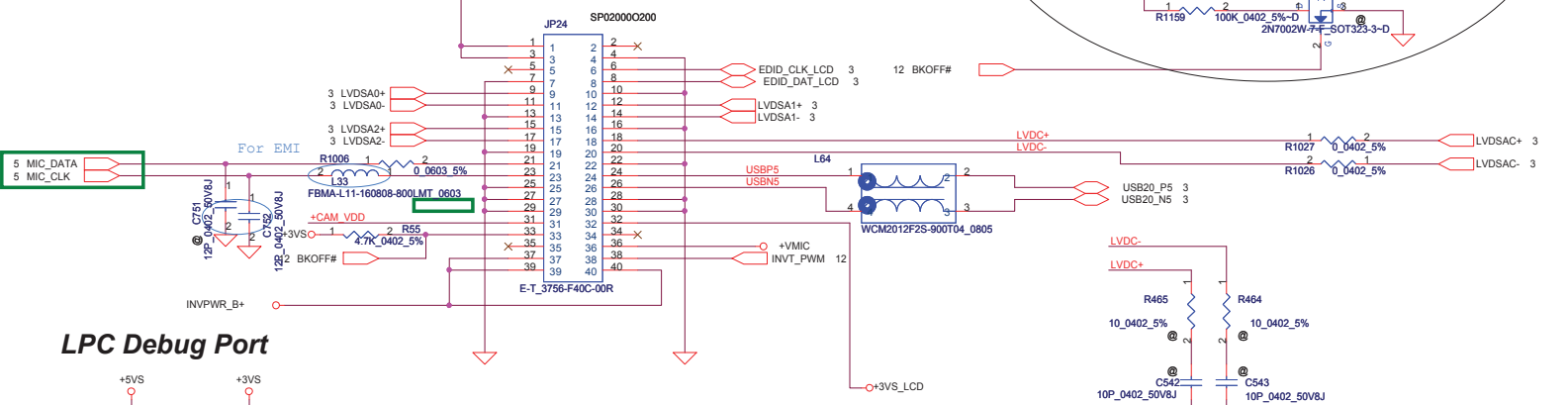
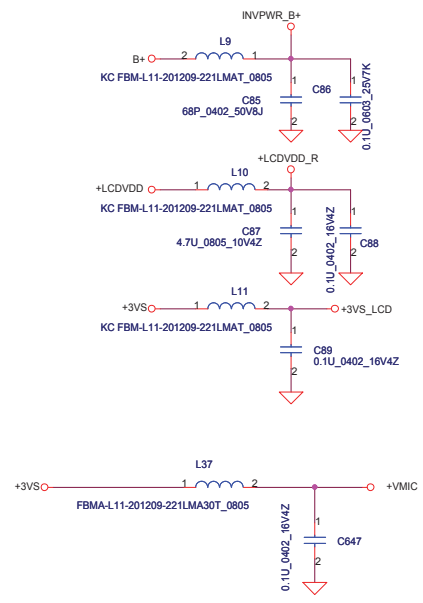

**LPC Debug Port**

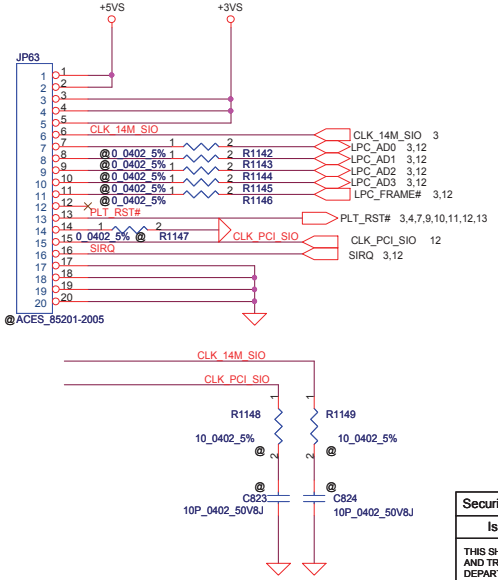

Security Classification		Compal Secret Data		Compal Electronics, Inc.	
Issued Date		Deciphered Date		Title	
				LCD Conn & Debug Port	
THIS SHEET OF ENGINEERING DRAWING IS THE PROPRIETARY PROPERTY OF COMPAL ELECTRONICS, INC. AND CONTAINS CONFIDENTIAL AND TRADE SECRET INFORMATION. THIS SHEET MAY NOT BE TRANSFERRED FROM THE CUSTODY OF THE COMPETENT DIVISION OF R&D DEPARTMENT EXCEPT AS AUTHORIZED BY COMPAL ELECTRONICS, INC. NEITHER THIS SHEET NOR THE INFORMATION IT CONTAINS MAY BE USED BY OR DISCLOSED TO ANY THIRD PARTY WITHOUT PRIOR WRITTEN CONSENT OF COMPAL ELECTRONICS, INC.		Size Custom		Document Number	
				KIU10 LA-4761P	
		Date: Tuesday, January 13, 2009		Rev 1.0	
		Sheet 8 of 22			



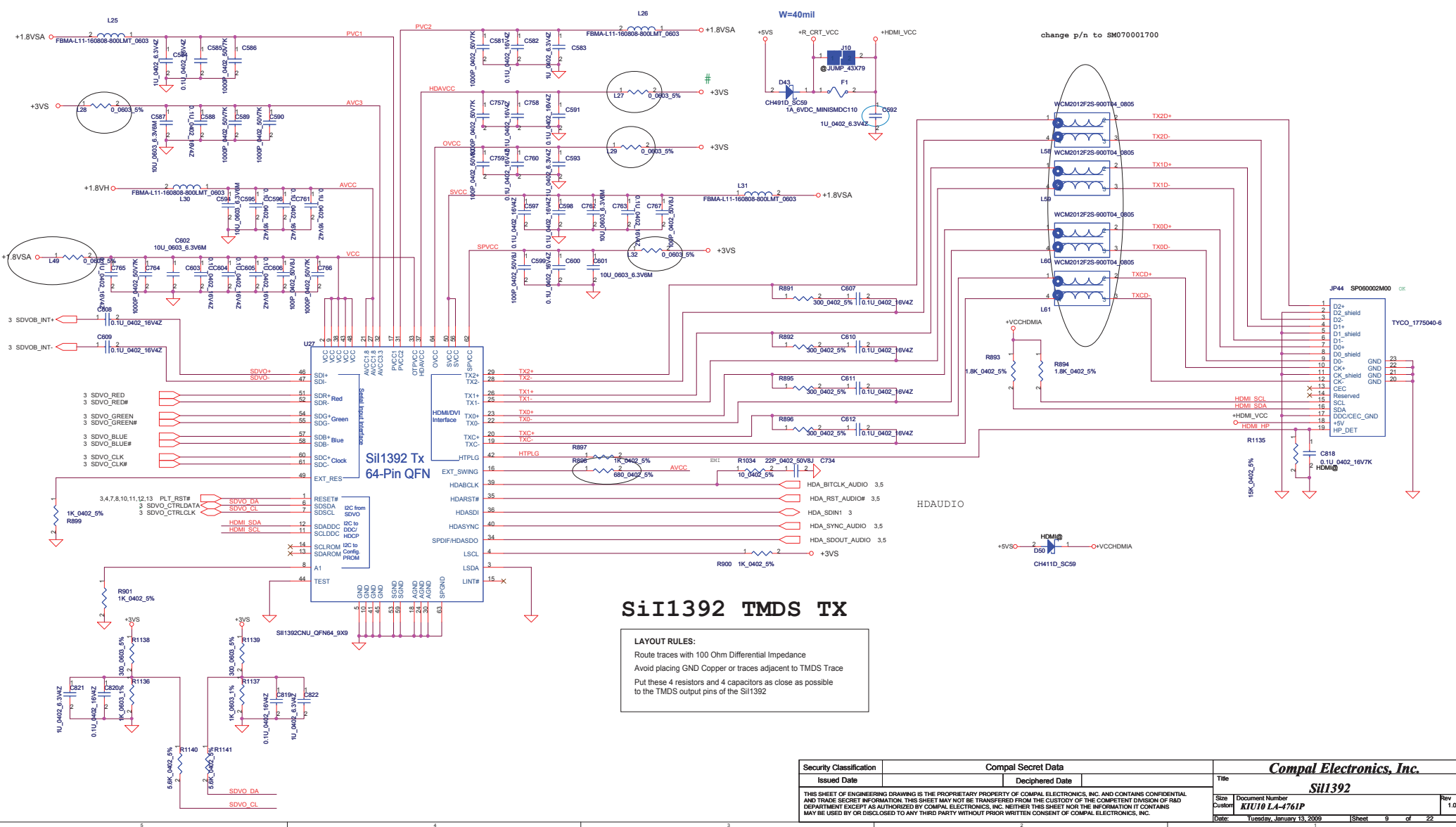

Security Classification	Compal Secret Data		Title <b>SiI1392</b>
Issued Date	Deciphered Date		
<small>THIS SHEET OF ENGINEERING DRAWING IS THE PROPRIETARY PROPERTY OF COMPAL ELECTRONICS, INC. AND CONTAINS CONFIDENTIAL AND TRADE SECRET INFORMATION. THIS SHEET MAY NOT BE TRANSFERRED FROM THE CUSTODY OF THE COMPETENT DIVISION OF R&amp;D DEPARTMENT EXCEPT AS AUTHORIZED BY COMPAL ELECTRONICS, INC. NEITHER THIS SHEET NOR THE INFORMATION IT CONTAINS MAY BE USED BY OR DISCLOSED TO ANY THIRD PARTY WITHOUT PRIOR WRITTEN CONSENT OF COMPAL ELECTRONICS, INC.</small>			Size: Document Number Custom: <b>KIU10 LA-4761P</b>
Date: Tuesday, January 13, 2009	Sheet: 9	of: 22	Rev: 1.0

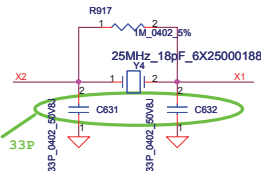
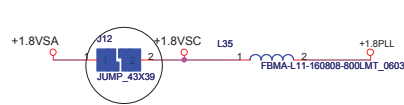

11/07:change C631,C632 from 22P to 33P

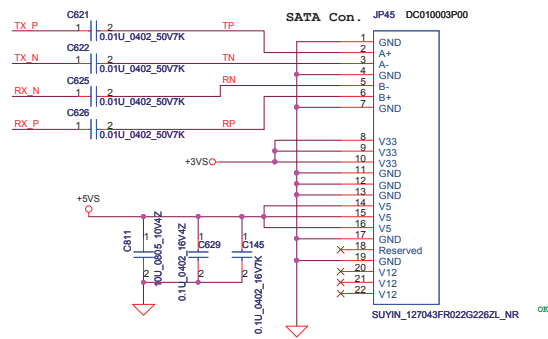
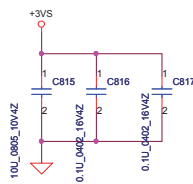
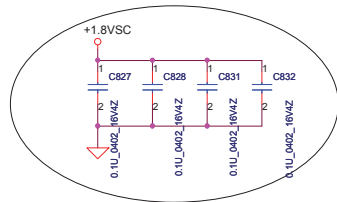
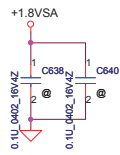
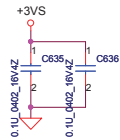
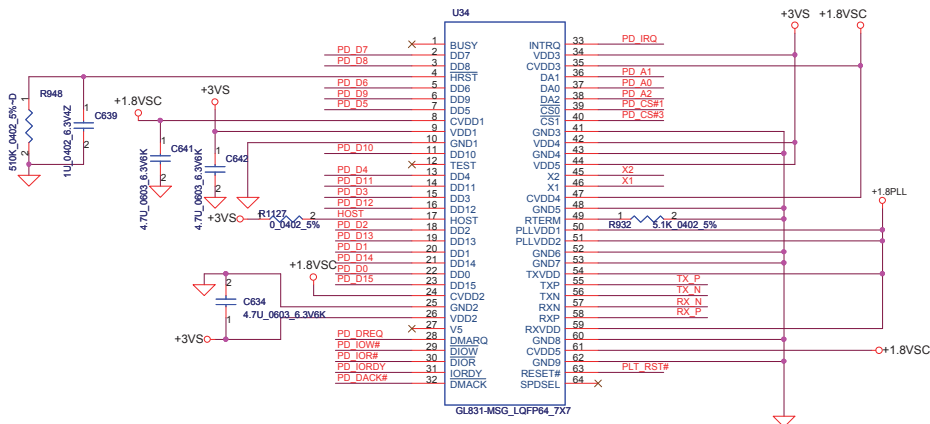
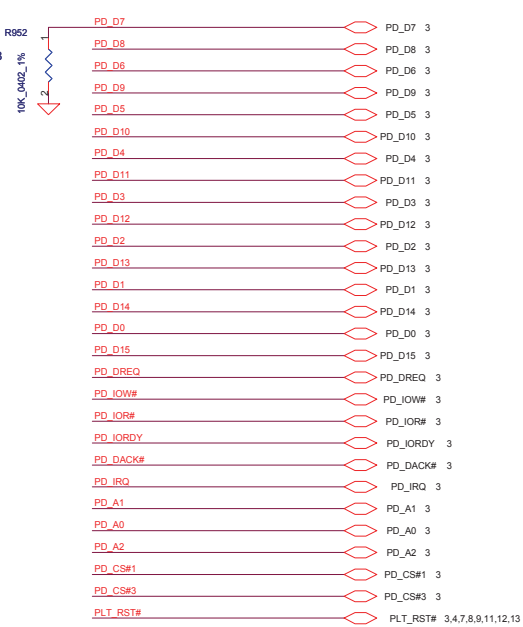

Security Classification	Compal Secret Data			Title	
Issued Date		Deciphered Date		Compal Electronics, Inc.	
THIS SHEET OF ENGINEERING DRAWING IS THE PROPRIETARY PROPERTY OF COMPAL ELECTRONICS, INC. AND CONTAINS CONFIDENTIAL AND TRADE SECRET INFORMATION. THIS SHEET MAY NOT BE TRANSFERRED FROM THE CUSTODY OF THE COMPETENT DIVISION OF R&D DEPARTMENT EXCEPT AS AUTHORIZED BY COMPAL ELECTRONICS, INC. NEITHER THIS SHEET NOR THE INFORMATION IT CONTAINS MAY BE USED BY OR DISCLOSED TO ANY THIRD PARTY WITHOUT PRIOR WRITTEN CONSENT OF COMPAL ELECTRONICS, INC.				PATA/SATA	
Size	Document Number	Rev	1.0		
Custom	KJ10 LA-4761P	Date:	Tuesday, January 13, 2009	Sheet	10 of 22



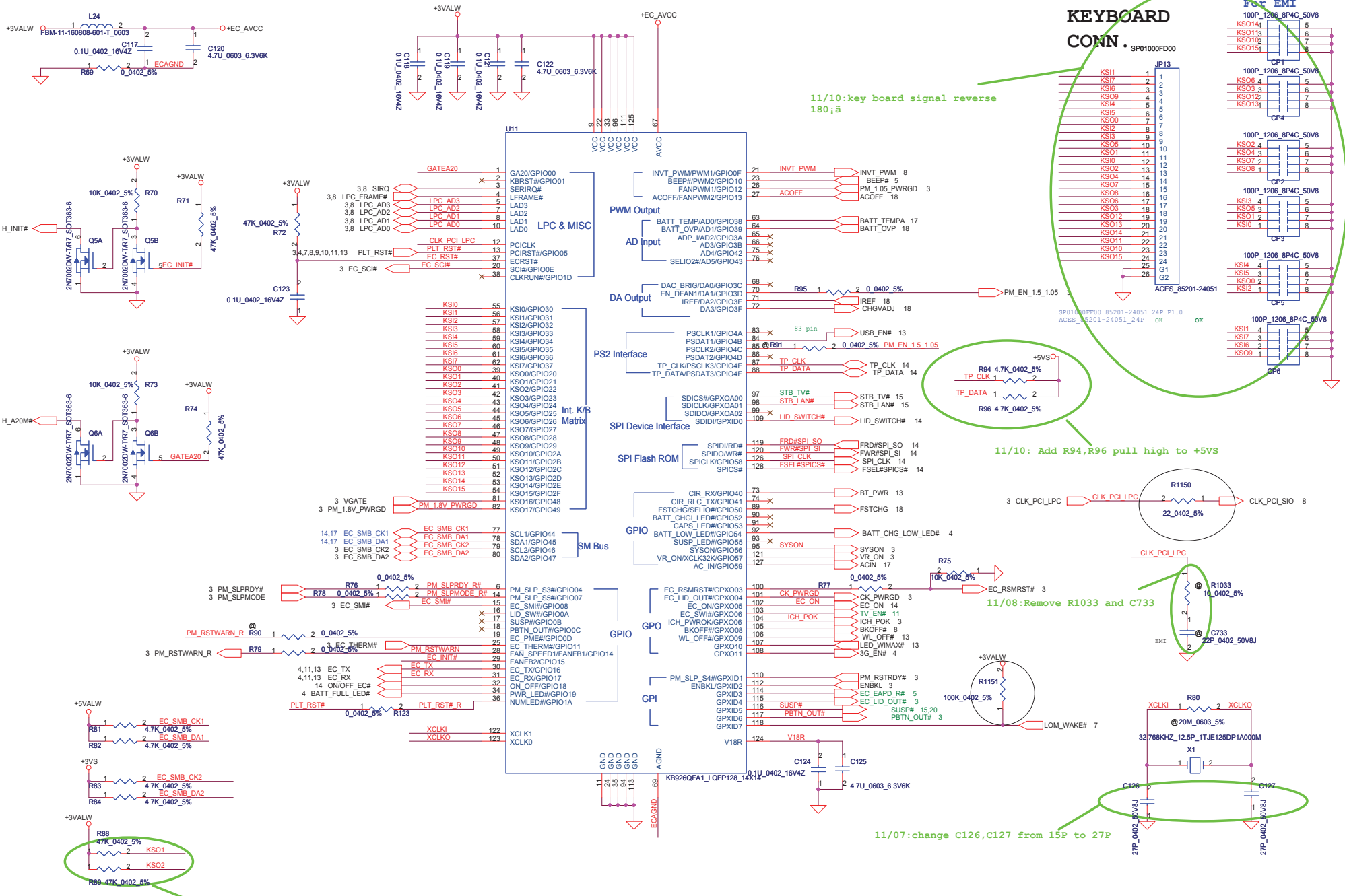

11/10: key board signal reverse 180;ä

11/10: Add R94, R96 pull high to +5VS

11/08: Remove R1033 and C733

11/09: Add Pull high resistor to pull high KSO1 and KSO2

Security Classification		Compal Secret Data		Title	
Issued Date		Deciphered Date		<b>Compal Electronics, Inc.</b> <b>ENE-KB926/KB Conn</b>	
<small>THIS SHEET OF ENGINEERING DRAWING IS THE PROPRIETARY PROPERTY OF COMPAL ELECTRONICS, INC. AND CONTAINS CONFIDENTIAL AND TRADE SECRET INFORMATION. THIS SHEET MAY NOT BE TRANSFERRED FROM THE CUSTODY OF THE COMPETENT DIVISION OF R&amp;D DEPARTMENT EXCEPT AS AUTHORIZED BY COMPAL ELECTRONICS, INC. NEITHER THIS SHEET NOR THE INFORMATION IT CONTAINS MAY BE USED BY OR DISCLOSED TO ANY THIRD PARTY WITHOUT PRIOR WRITTEN CONSENT OF COMPAL ELECTRONICS, INC.</small>				<small>Size</small> Custom <small>Document Number</small> <b>KI10U LA-4761P</b> <small>Date</small> Tuesday, January 13, 2009	<small>Rev</small> 1.0 <small>Sheet</small> 12 of 22

# PCIe Mini Card for WLAN/WiMax

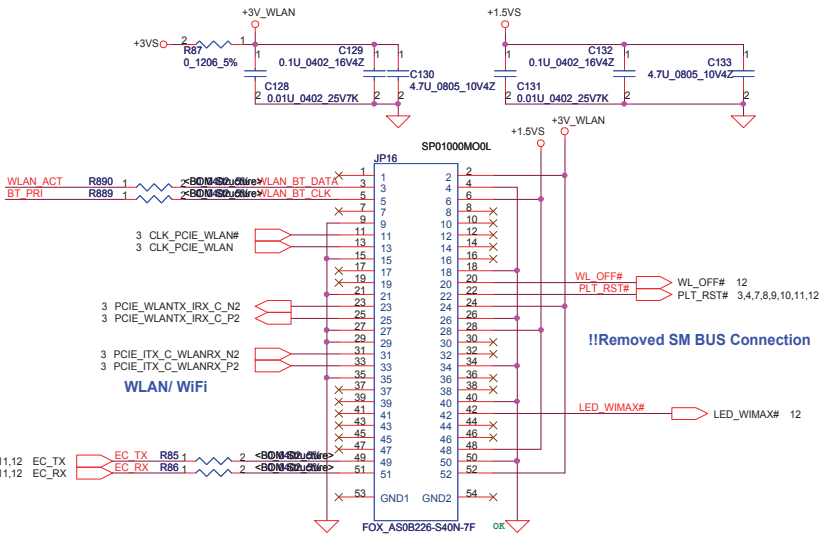

# On Board USB Connector

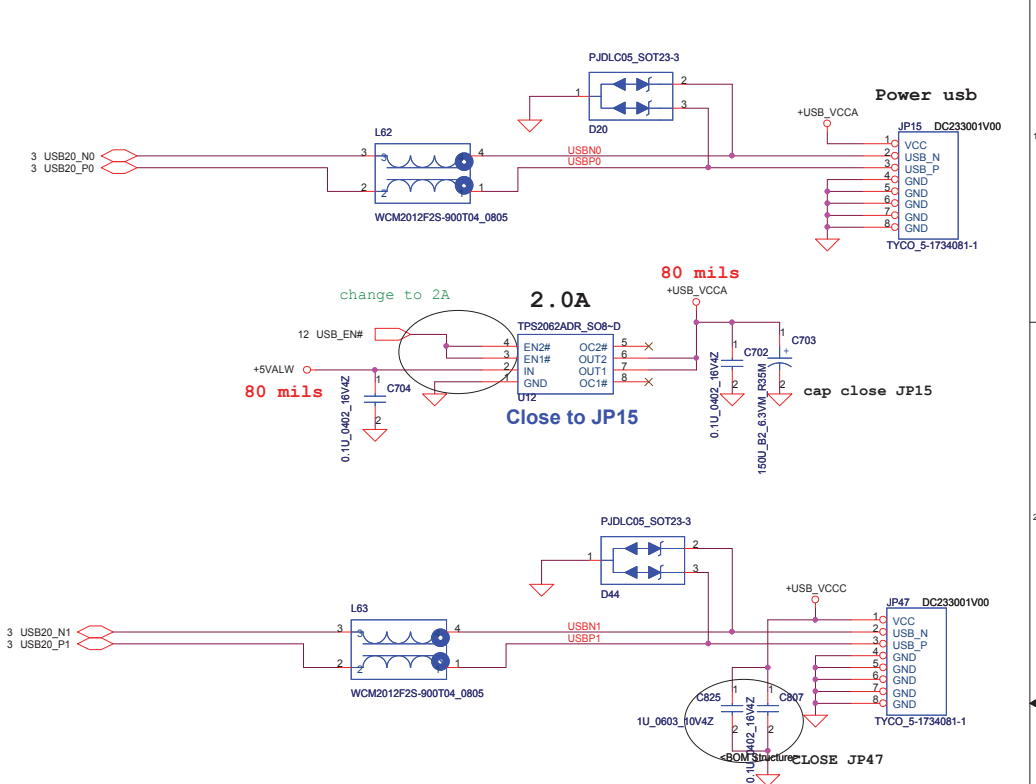

# BlueTooth Interface

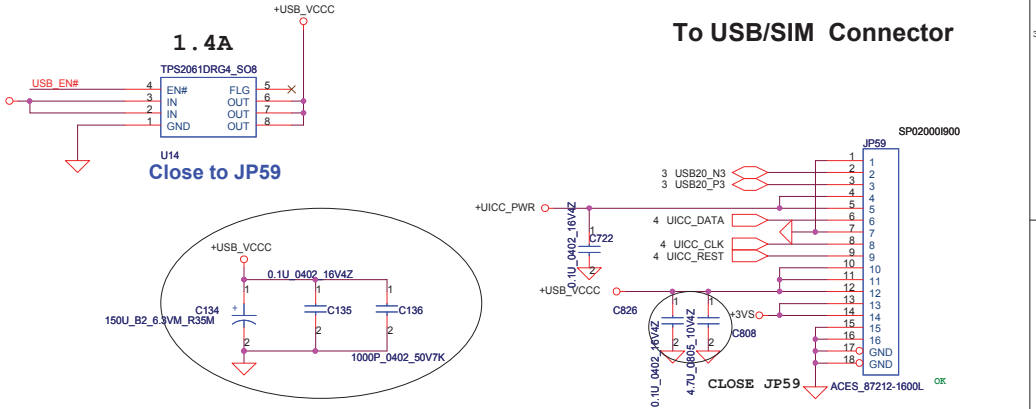
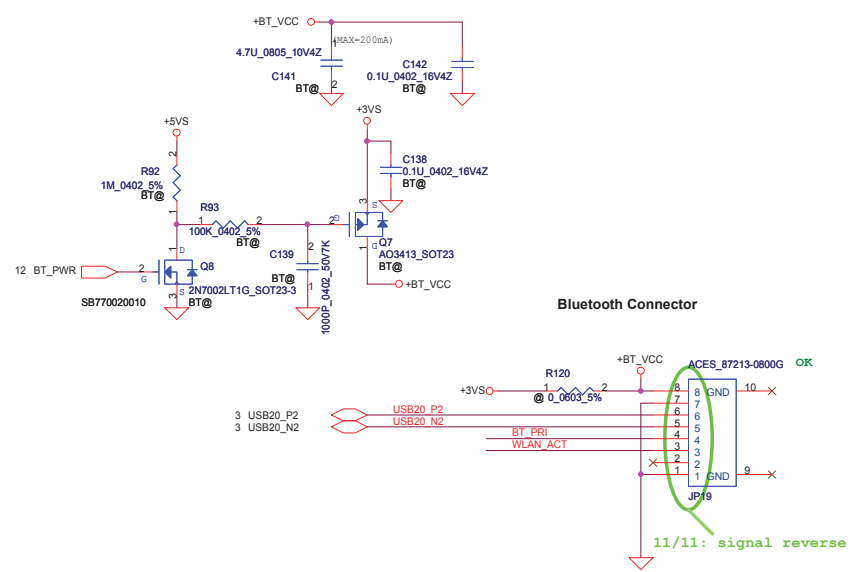

Security Classification	Compal Secret Data		Title	
Issued Date		Deciphered Date	WLAN/BT/PATA/USB/SIM	
THIS SHEET OF ENGINEERING DRAWING IS THE PROPRIETARY PROPERTY OF COMPAL ELECTRONICS, INC. AND CONTAINS CONFIDENTIAL AND TRADE SECRET INFORMATION. THIS SHEET MAY NOT BE TRANSFERRED FROM THE CUSTODY OF THE COMPETENT DIVISION OF R&D DEPARTMENT EXCEPT AS AUTHORIZED BY COMPAL ELECTRONICS, INC. NEITHER THIS SHEET NOR THE INFORMATION IT CONTAINS MAY BE USED BY OR DISCLOSED TO ANY THIRD PARTY WITHOUT PRIOR WRITTEN CONSENT OF COMPAL ELECTRONICS, INC.			Size Custom	Rev 1.0
Date: Tuesday, January 13, 2009	Sheet 13	of 22	Compal Electronics, Inc.	
			Document Number	KIU10 LA-4761P

# MB\_Power On/Off SW

## Lid SW

Change to hall sensor

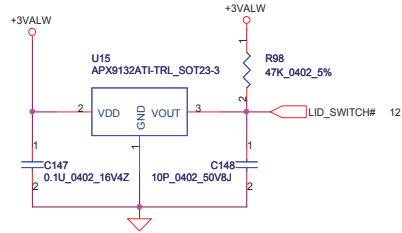

## RTC Reset SW (Place under door)

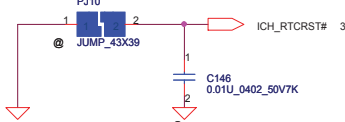

PUT ON TOP SIDE

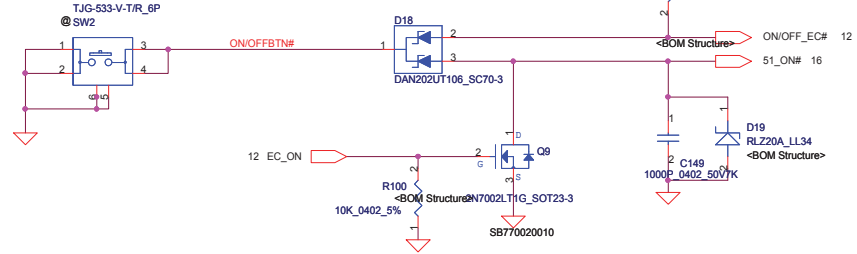

## POWER/B CONN.(to DB3)

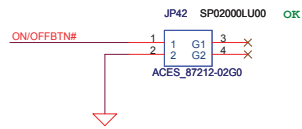

## Touch/B Connector

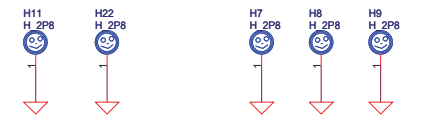
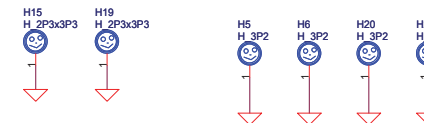
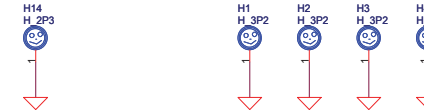
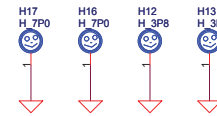
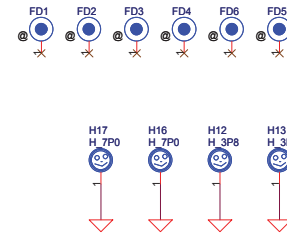
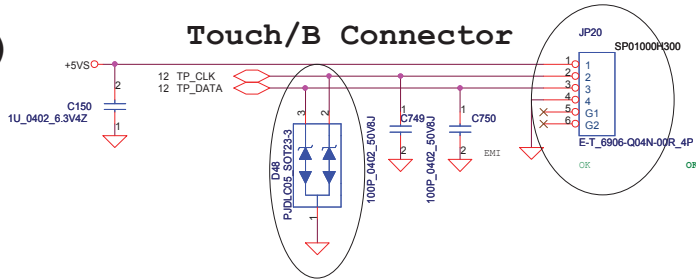

## System SPI Flash ROM (8Mb)

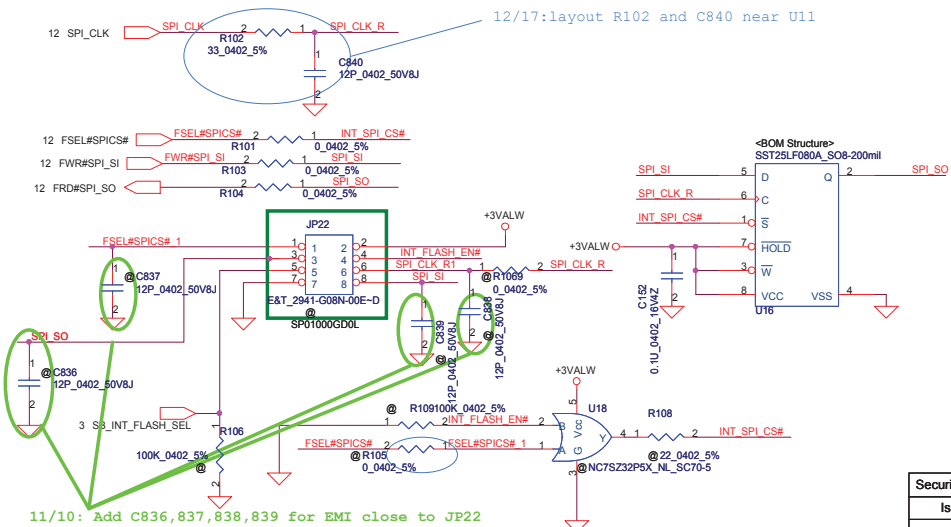

## EC EEPROM

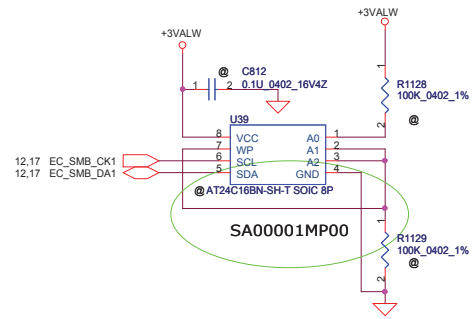

11/10: Add C836, 837, 838, 839 for EMI close to JP22

<http://hobi-elektronika.net>

Security Classification	Compal Secret Data		Title	
Issued Date		Deciphered Date	SW/ROM/TP/LID	
THIS SHEET OF ENGINEERING DRAWING IS THE PROPRIETARY PROPERTY OF COMPAL ELECTRONICS, INC. AND CONTAINS CONFIDENTIAL AND TRADE SECRET INFORMATION. THIS SHEET MAY NOT BE TRANSFERRED FROM THE CUSTODY OF THE COMPETENT DIVISION OF R&D DEPARTMENT EXCEPT AS AUTHORIZED BY COMPAL ELECTRONICS, INC. NEITHER THIS SHEET NOR THE INFORMATION IT CONTAINS MAY BE USED BY OR DISCLOSED TO ANY THIRD PARTY WITHOUT PRIOR WRITTEN CONSENT OF COMPAL ELECTRONICS, INC.			Size Custom	Rev 1.0
Date:	Tuesday, January 13, 2009	Sheet	14	of 22

**+5VALW TO +5VS**

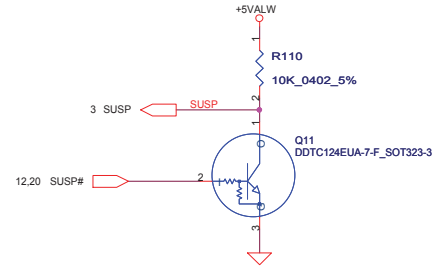
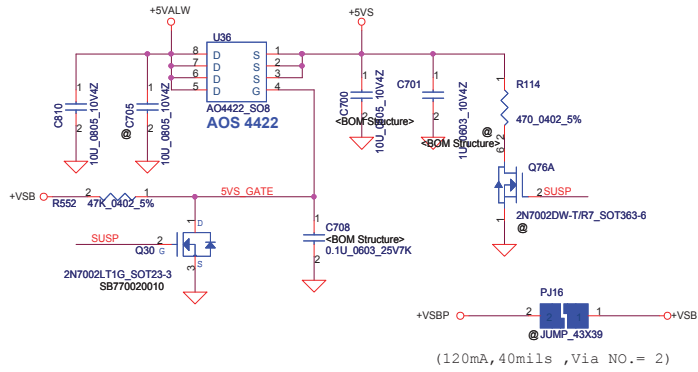

**+3VALW to +3VS Transfer**

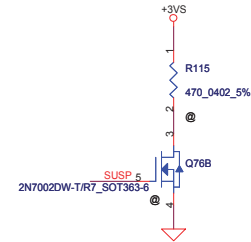
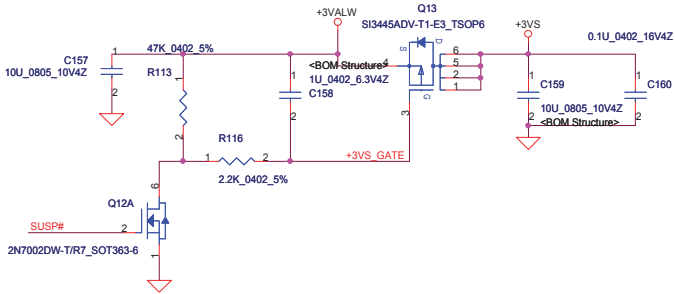

**+3VALW to +3V\_TV**

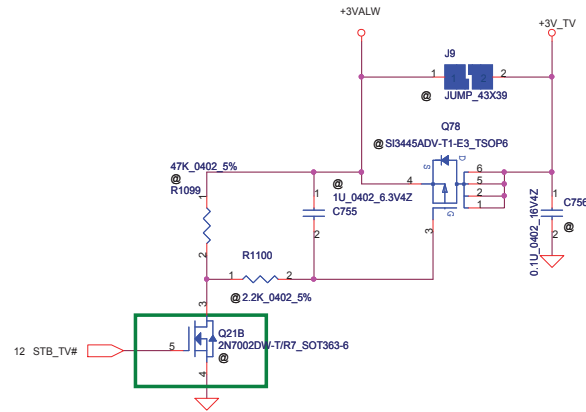

**+3VALW to +3V\_LAN**

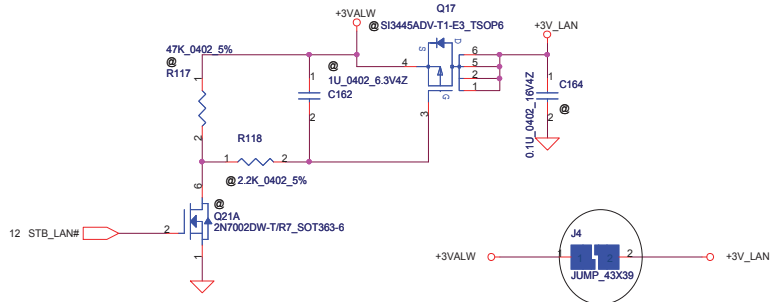

**PRODUCT SUMMARY**

Vgs	rDS(on)	ID (A)
-8	0.042 @ VGS = .4.5 V	+-.5,6
	0.060 @ VGS = .2.5 V	+-.4,7
	0.080 @ VGS = .1.8 V	+-.2,9

Security Classification	Compal Secret Data			<b>Compal Electronics, Inc.</b> <b>DC/DC Interface</b>		
Issued Date		Deciphered Date				
THIS SHEET OF ENGINEERING DRAWING IS THE PROPRIETARY PROPERTY OF COMPAL ELECTRONICS, INC. AND CONTAINS CONFIDENTIAL AND TRADE SECRET INFORMATION. THIS SHEET MAY NOT BE TRANSFERRED FROM THE CUSTODY OF THE COMPETENT DIVISION OF R&D DEPARTMENT EXCEPT AS AUTHORIZED BY COMPAL ELECTRONICS, INC. NEITHER THIS SHEET NOR THE INFORMATION IT CONTAINS MAY BE USED BY OR DISCLOSED TO ANY THIRD PARTY WITHOUT PRIOR WRITTEN CONSENT OF COMPAL ELECTRONICS, INC.				Title Document Number <b>KIU10 LA-4761P</b>	Rev 1.0	
Date: Tuesday, January 13, 2009				Sheet 15 of 22		

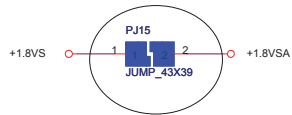
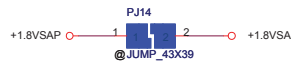
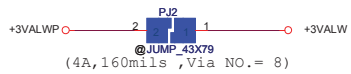
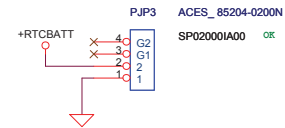
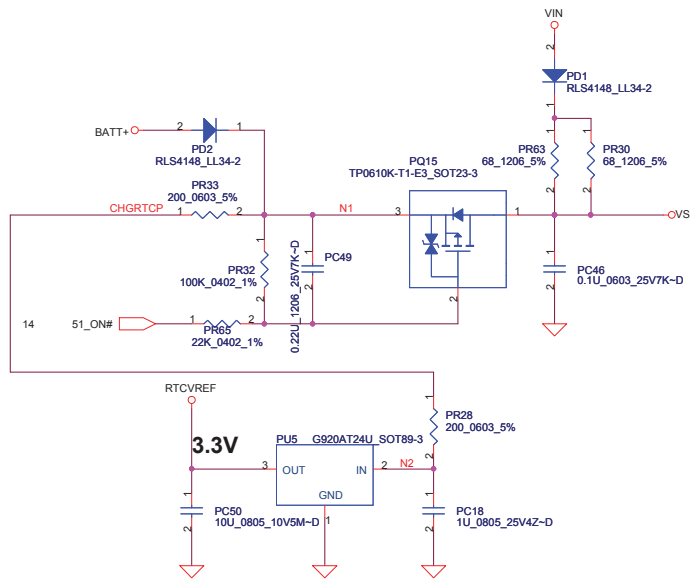
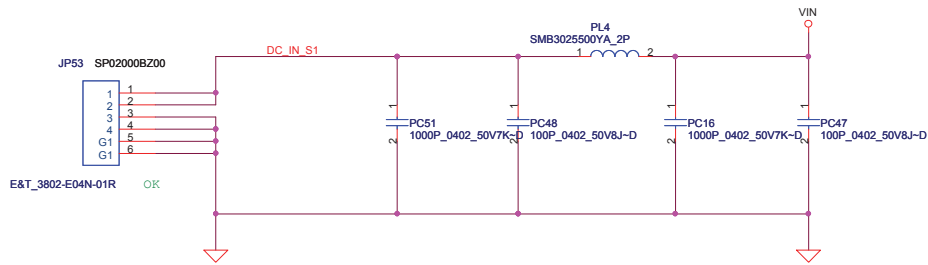

Security Classification	Compal Secret Data		Compal Electronics, Inc.	
Issued Date		Deciphered Date	Title <b>DCIN/DECTOR</b>	
THIS SHEET OF ENGINEERING DRAWING IS THE PROPRIETARY PROPERTY OF COMPAL ELECTRONICS, INC. AND CONTAINS CONFIDENTIAL AND TRADE SECRET INFORMATION. THIS SHEET MAY NOT BE TRANSFERRED FROM THE CUSTODY OF THE COMPETENT DIVISION OF R&D DEPARTMENT EXCEPT AS AUTHORIZED BY COMPAL ELECTRONICS, INC. NEITHER THIS SHEET NOR THE INFORMATION IT CONTAINS MAY BE USED BY OR DISCLOSED TO ANY THIRD PARTY WITHOUT PRIOR WRITTEN CONSENT OF COMPAL ELECTRONICS, INC.			Size	Document Number <b>KIU10 LA-4761P</b>
			Date: Tuesday, January 13, 2009	Rev 0.3
			Sheet 16	of 22



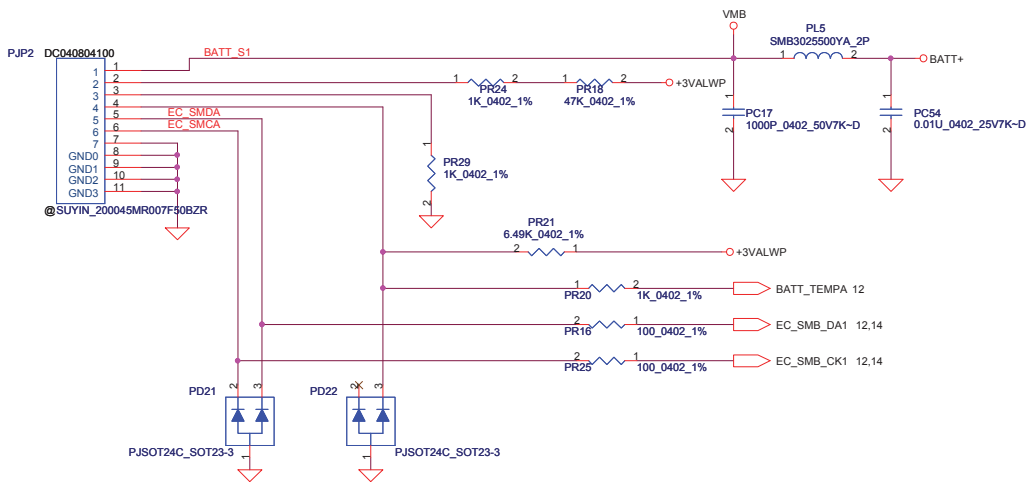

PH1 under CPU bottom side :  
 CPU thermal protection at 92 degree C  
 Recovery at 56 degree C

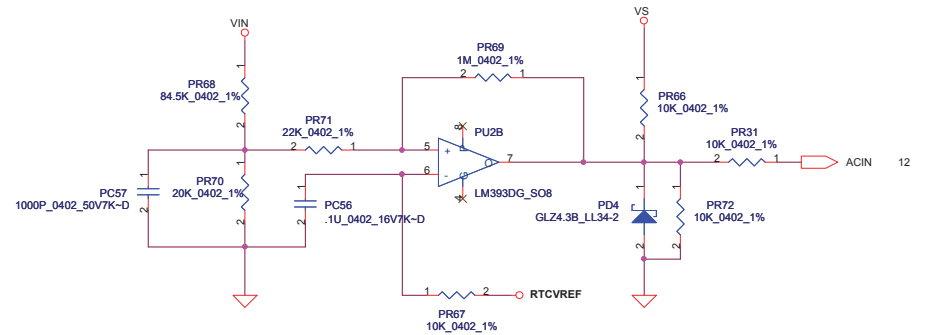
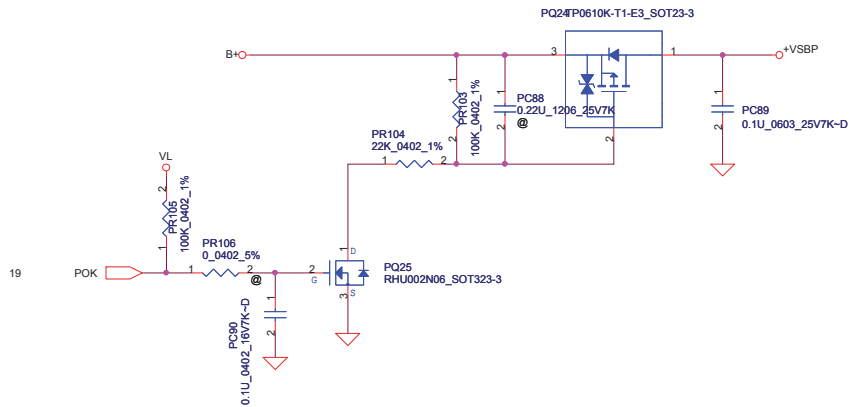
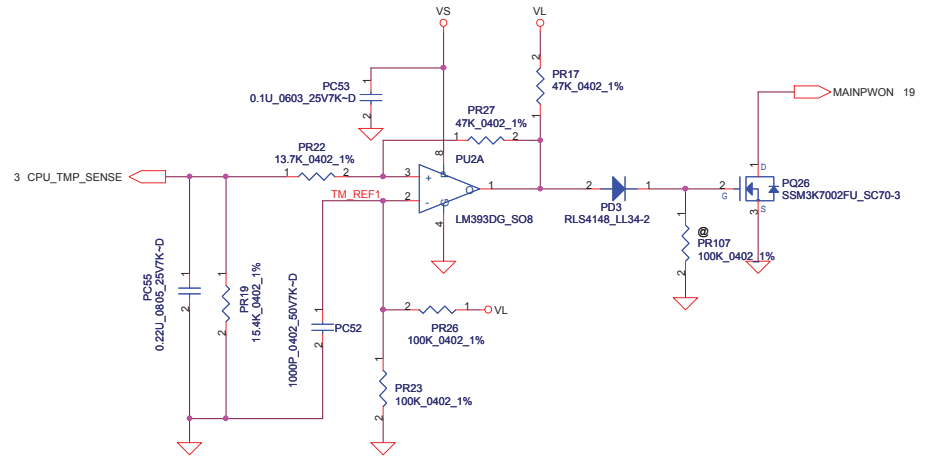

Vin Detector		
High	18.384	17.901
Low	17.728	16.976

Security Classification	Compal Secret Data		Title	
Issued Date		Deciphered Date	Compal Electronics, Inc.	
THIS SHEET OF ENGINEERING DRAWING IS THE PROPRIETARY PROPERTY OF COMPAL ELECTRONICS, INC. AND CONTAINS CONFIDENTIAL AND TRADE SECRET INFORMATION. THIS SHEET MAY NOT BE TRANSFERRED FROM THE CUSTODY OF THE COMPETENT DIVISION OF R&D DEPARTMENT EXCEPT AS AUTHORIZED BY COMPAL ELECTRONICS, INC. NEITHER THIS SHEET NOR THE INFORMATION IT CONTAINS MAY BE USED BY OR DISCLOSED TO ANY THIRD PARTY WITHOUT PRIOR WRITTEN CONSENT OF COMPAL ELECTRONICS, INC.			BATTERY CONN / OTP	
Size	Document Number	Rev		
	KIU10 LA-4761P	1.0		
Date:	Tuesday, January 13, 2009	Sheet	17	of 22

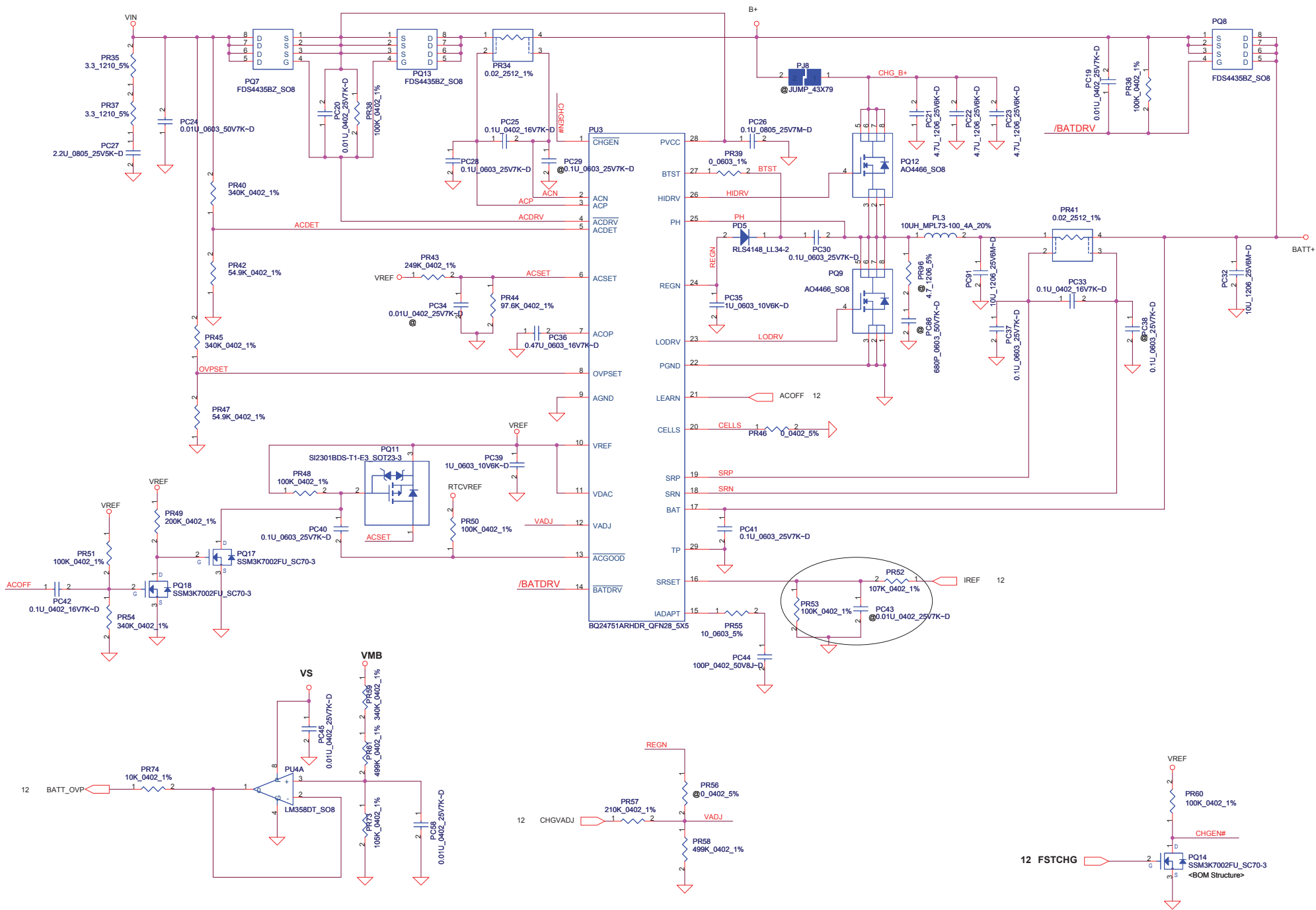

Security Classification	Compal Secret Data		Compal Electronics, Inc.	
Issued Date	2008/05/30	Deciphered Date	2011/05/30	Title
THIS SHEET OF ENGINEERING DRAWING IS THE PROPRIETARY PROPERTY OF COMPAL ELECTRONICS, INC. AND CONTAINS CONFIDENTIAL AND TRADE SECRET INFORMATION. THIS SHEET MAY NOT BE TRANSFERRED FROM THE CUSTODY OF THE COMPETENT DIVISION OF R&D DEPARTMENT EXCEPT AS AUTHORIZED BY COMPAL ELECTRONICS, INC. NEITHER THIS SHEET NOR THE INFORMATION IT CONTAINS MAY BE USED BY OR DISCLOSED TO ANY THIRD PARTY WITHOUT PRIOR WRITTEN CONSENT OF COMPAL ELECTRONICS, INC.				CHARGER
Size	Document Number	Rev		
	KIU10 LA-4761P	0.3		
Date:	Tuesday, January 13, 2009	Sheet	18 of 22	

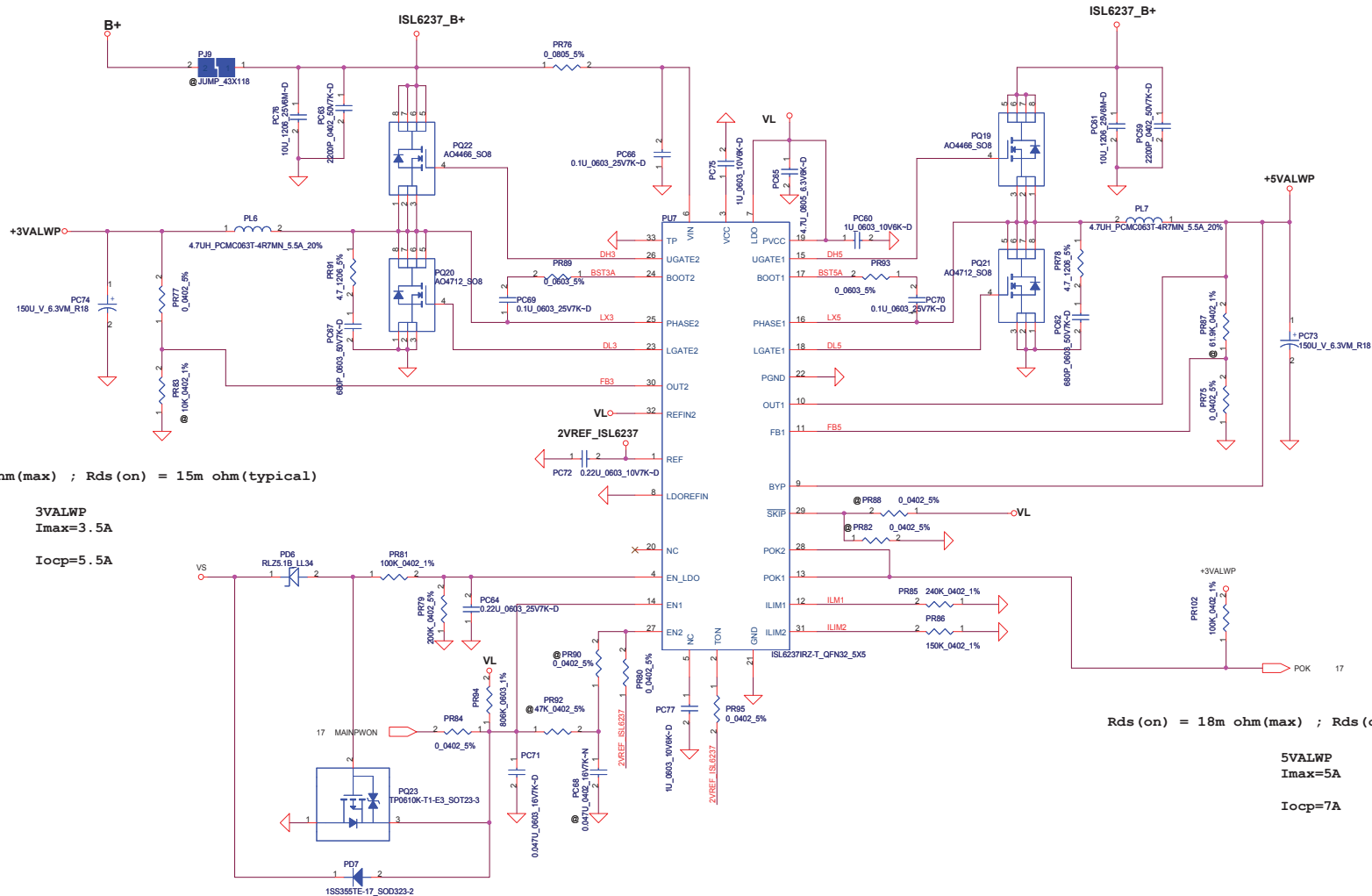

$R_{ds(on)} = 18\text{m ohm(max)} ; R_{ds(on)} = 15\text{m ohm(typical)}$

**3VALWP**  
 $I_{max}=3.5\text{A}$   
 $I_{ocp}=5.5\text{A}$

$R_{ds(on)} = 18\text{m ohm(max)} ; R_{ds(on)} = 15\text{m ohm(typical)}$

**5VALWP**  
 $I_{max}=5\text{A}$   
 $I_{ocp}=7\text{A}$

Security Classification		Compal Secret Data		Compal Electronics, Inc.		
Issued Date		Deciphered Date		Title	<b>+3VALWP/+5VALWP</b>	
THIS SHEET OF ENGINEERING DRAWING IS THE PROPRIETARY PROPERTY OF COMPAL ELECTRONICS, INC. AND CONTAINS CONFIDENTIAL AND TRADE SECRET INFORMATION. THIS SHEET MAY NOT BE TRANSFERRED FROM THE CUSTODY OF THE COMPETENT DIVISION OF R&D DEPARTMENT EXCEPT AS AUTHORIZED BY COMPAL ELECTRONICS, INC. NEITHER THIS SHEET NOR THE INFORMATION IT CONTAINS MAY BE USED BY OR DISCLOSED TO ANY THIRD PARTY WITHOUT PRIOR WRITTEN CONSENT OF COMPAL ELECTRONICS, INC.				Size	Document Number	Rev
				C	KIU10 LA-4761P	0.3
				Date:	Tuesday, January 13, 2009	Sheet 18 of 22

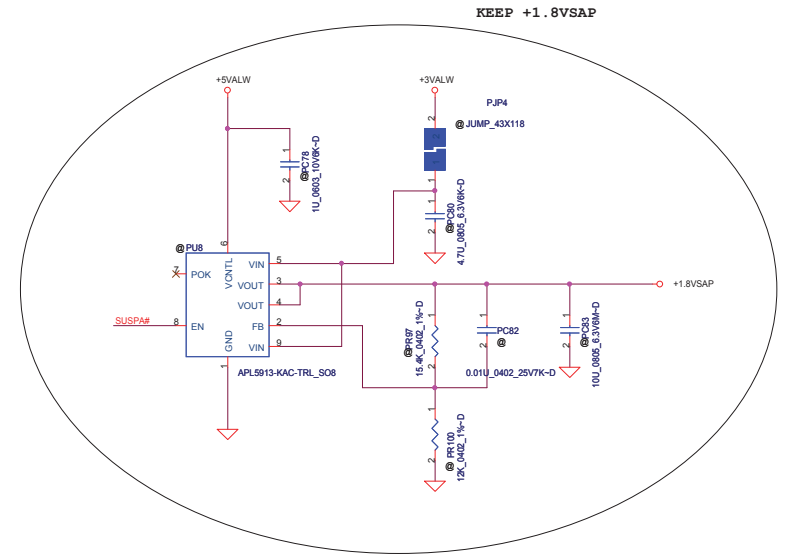
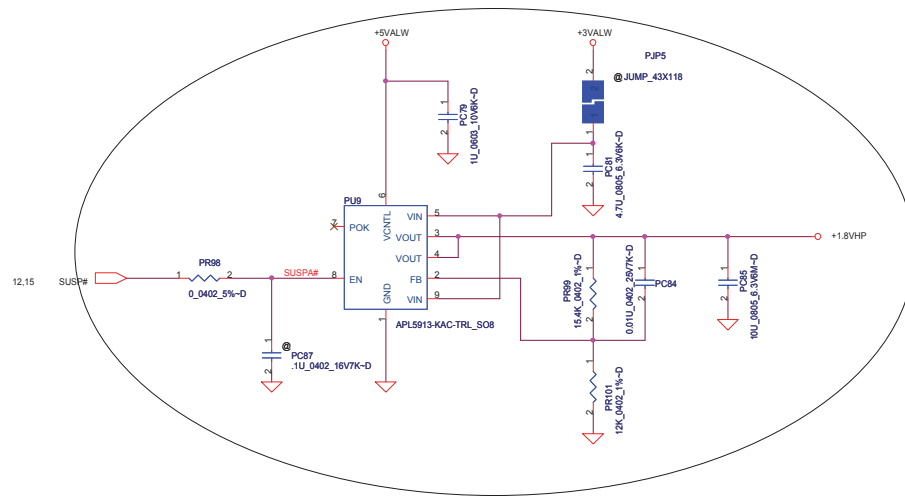

KEEP +1.8VSAP

Security Classification		Compal Secret Data		Compal Electronics, Inc.	
Issued Date		Deciphered Date		Title	
				+1.8VHP / +1.8VSAP	
THIS SHEET OF ENGINEERING DRAWING IS THE PROPRIETARY PROPERTY OF COMPAL ELECTRONICS, INC. AND CONTAINS CONFIDENTIAL AND TRADE SECRET INFORMATION. THIS SHEET MAY NOT BE TRANSFERRED FROM THE CUSTODY OF THE COMPETENT DIVISION OF R&D DEPARTMENT EXCEPT AS AUTHORIZED BY COMPAL ELECTRONICS, INC. NEITHER THIS SHEET NOR THE INFORMATION IT CONTAINS MAY BE USED BY OR DISCLOSED TO ANY THIRD PARTY WITHOUT PRIOR WRITTEN CONSENT OF COMPAL ELECTRONICS, INC.		Size C		Document Number KIU10 LA-4761P	
Date: Tuesday, January 13, 2009		Sheet 20 of 22		Rev 0.3	

NO	DATE	PAGE	MODIFICATION LIST	PURPOSE
1	0907	03	del C729,C730,C727,C728	MODIFY HDMI CLK.
2	0907	03	J5,J6,J11 del bom structure	default
3	0907	06	RTS158E's pin11 and Pin9 should be isolate,define pin23,pin26	vendor suggestion
4	0907	05	modify R1113,R1114,ADD L65 L66 D51,	vendor suggestion
5	0918	03	add LEC debug port	vendor require
6	0918	15	modify Q30 P/N as same Q8	for same P/N
7	0918	12	del R458,C539,R1008,add R1150,R1151,R1152	Correct BOM
8	0918	06	add bom structure # R1032,C731	Correct BOM
9	0918	14	add bom structure # U39,R1128,R1129	Correct BOM
10	0918	18	adjust PR52,PR53,PC43	Power team require
11	0918	20	add bom structure # page 20	Power team require
12	0918	06	R1030,R1031 change to 0 ohm,R440,R446 change to 33 ohm,R454,R458 change to 0603 package,	correct schematic
13	0918	06	Add one 0.1uF (C525)and 1uF (C826,0603) on JP59 pin 10 for +USB_VCC	correct schematic
14	0918	06	change p/n to SM070001700	correct schematic
15	0918	15	del J4 bom structure	correct schematic
16	0918	16	del PJ15 bom structure	correct schematic
17	0919	06	u25 short pin8 and pin11/33 together	correct schematic
18	0919	13	u12 pin3 connector to pin 4	correct schematic
19	0922	05	add bom structure # C804	vendor require
20	0922	13	CHANGE C134,C135,C138 FROM +USB_VCCA TO +USB_VCCC	noise issue when s3 resume
21	0923	16	merge +1.8VDA,+1.8VM	FOR PORT 3 USB VOLTAGE
22	0924	10	add +1.8Vsc Voltage	correct schematic
23	0924	05	SET MIC2 BOM #	me require
24	0924	14	change JP20 pin defin	correct schematic
25	0924	08	add LED invert switch circuit	correct schematic
26	0924	03	Add R1161 on JP5 pin10 for LPC_FRAME#	correct schematic
27	0924	09	Change 0ohm location to L*	correct schematic
28	0924	09	C809 move to page by 3	correct schematic
29	0924	05	Del MIC1	correct schematic
30	0924	12	add R1150 for CLK_PCI_LPC	correct schematic
31	1107	04	change R573 from 120 ohm to 470 ohm	correct schematic
32	1107	06	change C511, C515 from 6P to 22P	LED is too light
33	1107	07	change C59, C60 from 27P to 33P	correct schematic
34	1107	10	change C631, C632 from 22P to 33P	correct schematic
35	1107	12	change C126, C127 from 15P to 27P	correct schematic
36	1108	03	change R1130 from 0 ohm to 22 ohm	correct schematic
37	1108	12	Remove R1033 and C733	correct schematic
38	1109	07	Add Orange LED	correct schematic
39	1109	12	Add pull high resistor to KS01 and KS02	correct schematic
40	1110	03	Add C834,C835 (12pF) for EMI	Correct schematic
41	1110	14	Add C836,C837,C838,C839,C840 (12pF) for EMI	For EMI
42	1110	12	Key board signal reverse	key board signal reverse
43	1110	12	ADD R94,R96 pull high resistor to +5V	Correct schematic
44	1111	11	Add J13 to connect +3VS to +3V_TV	TV turner issue
45	1111	11	JP19 signal reverse	Correct schematic
46	1113	14	Remove R1067,R1068,R1069	Correct schematic
47	1113	08	Add C751,C752 for EMI	For EMI
48	1202	03	Remove R1009,R1132,C833	For Audio can not work issue
49	1202	03	Change R1152 from 10K ohm to 1.5M ohm	For Audio can not work issue
50	1202	14	reverse T/P CONN signal	Correct schematic
51	1209	04	change DA1 and DA2 to +5V_ALM	Correct schematic
52	1209	04	Add and gate to PLT_RST# to 3G function	TV turner issue
53	1211	07	Add Bead for EMI on +3V_LAN to LAN connect	For EMI
54	1212	09	change C592 from 0.1u to 1u	Correct schematic
55	1212	11	change JP54 power from +3VS to +3V_TV	Correct schematic
56	1215	04	change R573 from 470 to 820	LED too light issue
57	1216	14	Add R105(0 ohm) to cut off FSEL#SPIC# to JP22&U18	Correct schematic
58	1217	08	Change R1007(0ohm) to L33(FBMA-L11-160808-800LMT )	For EMI
59	1217	03	change U8 circuit design	For EMI
60	0102	03	Remove U8 circuit design and Add R1153	Correct schematic

Security Classification		Compal Secret Data		<b>Compal Electronics, Inc.</b>	
Issued Date		Deciphered Date		Title	
				<b>PIR</b>	
Size		Document Number		Rev	
Customer		<b>KIU10 LA-4761P</b>		1.0	
Date:		Tuesday, January 13, 2009		Sheet 21 of 22	

THIS SHEET OF ENGINEERING DRAWING IS THE PROPRIETARY PROPERTY OF COMPAL ELECTRONICS, INC. AND CONTAINS CONFIDENTIAL AND TRADE SECRET INFORMATION. THIS SHEET MAY NOT BE TRANSFERRED FROM THE CUSTODY OF THE COMPETENT DIVISION OF R&D DEPARTMENT EXCEPT AS AUTHORIZED BY COMPAL ELECTRONICS, INC. NEITHER THIS SHEET NOR THE INFORMATION IT CONTAINS MAY BE USED BY OR DISCLOSED TO ANY THIRD PARTY WITHOUT PRIOR WRITTEN CONSENT OF COMPAL ELECTRONICS, INC.