

Enrico 14
Muxless Discrete/UMA Schematics Document
AMD Ontario CPU FT1
AMD GPU Seymour XT
FCH HUDSON M1
PCB :10265
2010-04-21
REV : A00

DY :None Installed
UMA:UMA and Muxless platform installed
DIS_PX:DIS and Muxless platform installed
PSL:10mW internal schematic
10mW: 10mW schematic installed
Surge: Surege schematic installed
GIGA: GIGA schematic installed
10/100: 10/100 schematic installed
ROB: ROBOSON GPU installed

Project code : 91.4IU01.001
 PCB P/N :
 Revision : 10265-1

AMD Brazos UMA/Discrete Block Diagram

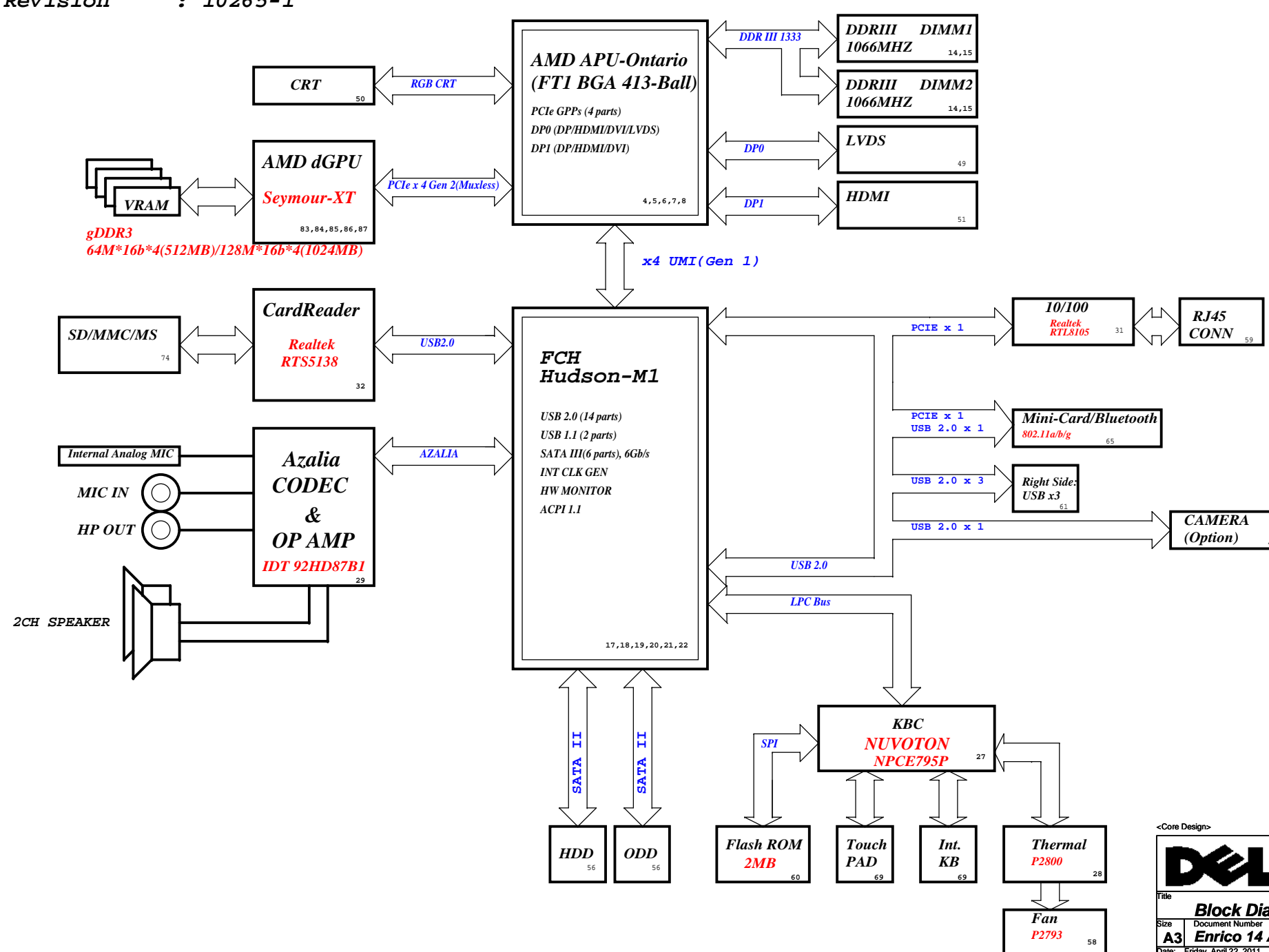

CHARGER BQ24707 40	
INPUTS	OUTPUTS
AD+	DCBATOUT
BT+	
SYSTEM DC/DC TPS51125A 41	
INPUTS	OUTPUTS
DCBATOUT	3D3V_AUX_S5 5V_AUX_S5 5V_S5 3D3V_S5
APU Core/NB Power ISL6265CHRTZ-T 42, 43	
INPUTS	OUTPUTS
DCBATOUT	APU_VDD APU_VDDNB
DDR III SUS TPS51216RUKR 44	
INPUTS	OUTPUTS
DCBATOUT	1D5V_S3
DDR III VTT TPS51216RGER 44	
INPUTS	OUTPUTS
DCBATOUT	0D75V_S0
APU VDDR/VDDP TPS51218 46	
INPUTS	OUTPUTS
DCBATOUT	1D1V_S5
AMD APU/FCH CORE Power TPS51218 46	
INPUTS	OUTPUTS
DCBATOUT	1V_S0
AMD GPU CORE RT8208BGQW 92	
INPUTS	OUTPUTS
DCBATOUT	VGA_CORE
AMD GPU CORE RT8015B 47	
INPUTS	OUTPUTS
3D3V_S5	1D8V_S0

PCB LAYER	
L1:	Top
L2:	VCC
L3:	Signal
L4:	Signal
L5:	GND
L6:	Bottom

<Core Design>

Wistron Corporation
 21F, 88, Sec.1, Hsin Tai Wu Rd., Hsichih,
 Taipei Hsien 221, Taiwan, R.O.C.

Title: **Block Diagram**

Size: A3	Document Number: Enrico 14 AMD	Rev: A00
Date: Friday, April 22, 2011	Sheet: 2 of	109

REQUIRED SYSTEM STRAPS

	AZ_SDOUT	PCI_CLK1	CLK_PCI_LPC	PCI_CLK4	LPC_CLK0	LPC_CLK1	LPC_CLK2
PULL HIGH	LOW POWER MODE	Allow PCIE GEN2 DEFAULT	USE DEBUG STRAPS	non_Fusion CLOCK mode	ENABLE EC	CLKGEN ENABLED (Use Internal) DEFAULT	Enable boot timer function
PULL LOW	PERFORMANCE MODE DEFAULT	Force PCIE GEN1	IGNORE DEBUG STRAPS DEFAULT	Fusion CLOCK mode DEFAULT	DISABLE EC DEFAULT	CLKGEN DISABLED (Use External)	Disable boot fail timer function DEFAULT

TYPE ENABLED	EC_PWM2	EC_PWM3
Reserved	2.2-kohm 5% pull-down	2.2-kohm 5% pull-down
LPC ROM	Not connected.	2.2-kohm 5% pull-down
SPI ROM	2.2-kohm 5% pull-down	Not connected.
Reserved	Not connected.	Not connected.

Note: EC_PWM2, EC_PWM3 default have internal 10kohm PU.

USB Table

Pair	USB Device
0	USB 2.0 EXT.Port1
1	Mini Card1 (WLAN)
2	USB 2.0 EXT.Port1
3	NC
4	NC
5	NC
6	USB 2.0 EXT.Port1
7	CCD Camera
8	NEWCARD
9	Card Reader
10	NC
11	NC
12	NC
13	NC

PCIe Routing

	APU
LANE0	LAN
LANE1	WWAN
LANE2	WLAN
LANE3	CardReader

<Core Design>

DELL		Wistron Corporation	
		21F, 88, Sec. 1, Hsin Tai Wu Rd., Hsichih, Taipei Hsien 221, Taiwan, R.O.C.	
Title Table of Content			
Size A3	Document Number Enrico 14 AMD	Rev A00	
Date: Friday, April 22, 2011	Sheet 3	of 109	

SSID = CPU

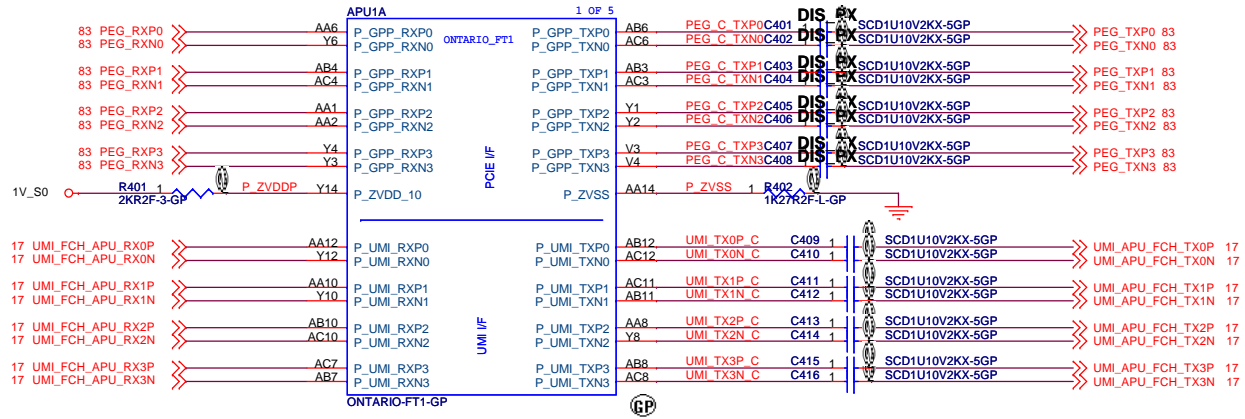

<Core Design>

DELL		Wistron Corporation	
		21F, 88, Sec.1, Hsin Tai Wu Rd., Hsichih, Taipei Hsien 221, Taiwan, R.O.C.	
Title: APU PCIE(1/5)			
Size: A3	Document Number: Enrico 14 AMD	Rev: A00	
Date: Friday, April 22, 2011	Sheet: 4	of	109

SSID = CPU

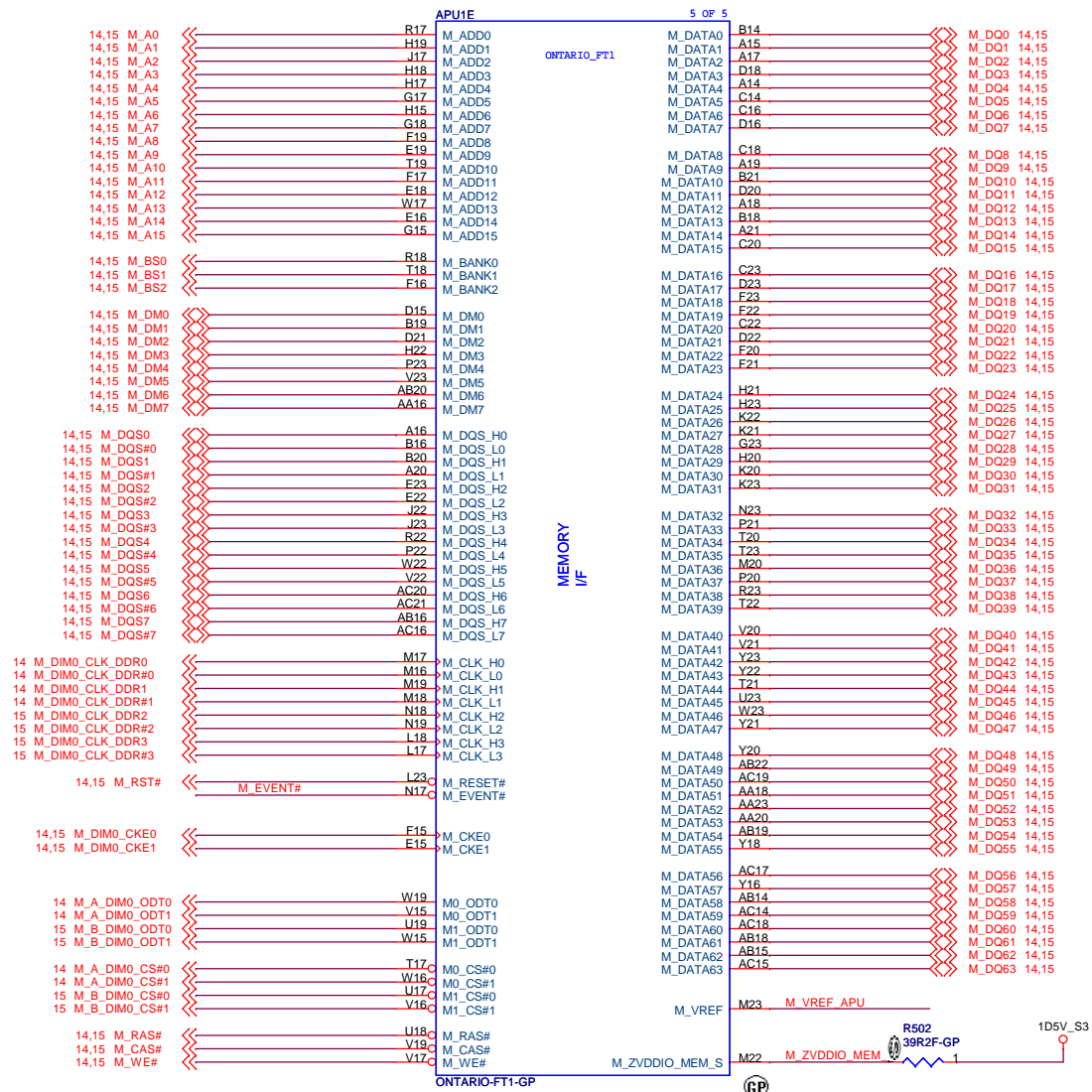

APU_VREF

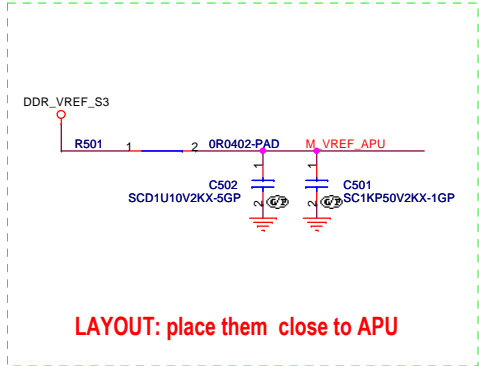

LAYOUT: place them close to APU

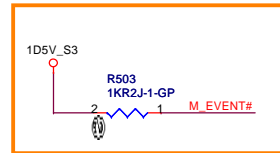

AMD Confirm: PU Needed even if not used

<Core Design>



Title APU DDR(2/5)		
Size A3	Document Number Enrico 14 AMD	Rev A00
Date: Friday, April 22, 2011	Sheet 5 of 109	

SSID = CPU

SVC	SVD	Boot Voltage (VCC/GND)	Boot Voltage (open)
0	0	1.1	1.1
0	1	1.0	1.2
1	0	0.9	1.1
1	1	0.8	0.9

Brazos: DPl --> HDMI
 Sabine: DPO --> LVDS
 DPl --> CRT
 DP2 --> HDMI

APU_TEST33_H_M_CLKTST_H SCD1U10V2KX-5GP R602 1 R603 51R2F-2-GP
 APU_TEST33_L_M_CLKTST_L SCD1U10V2KX-5GP R603 1 R602 51R2F-2-GP

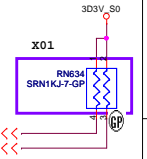
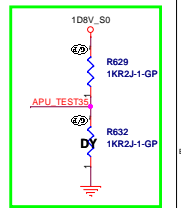
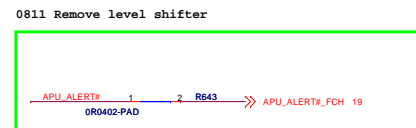
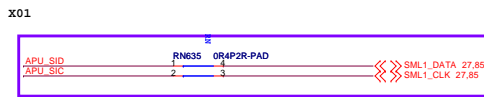
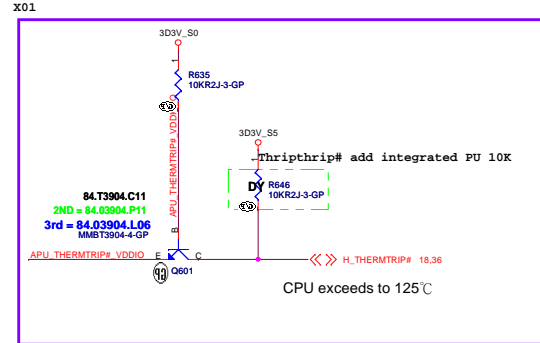
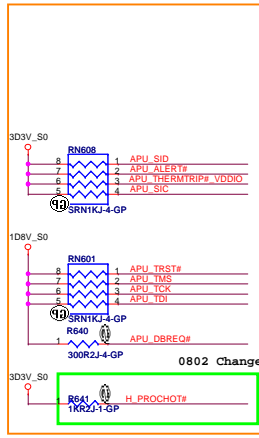
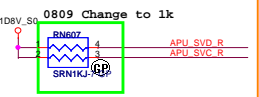
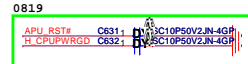
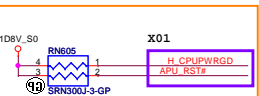
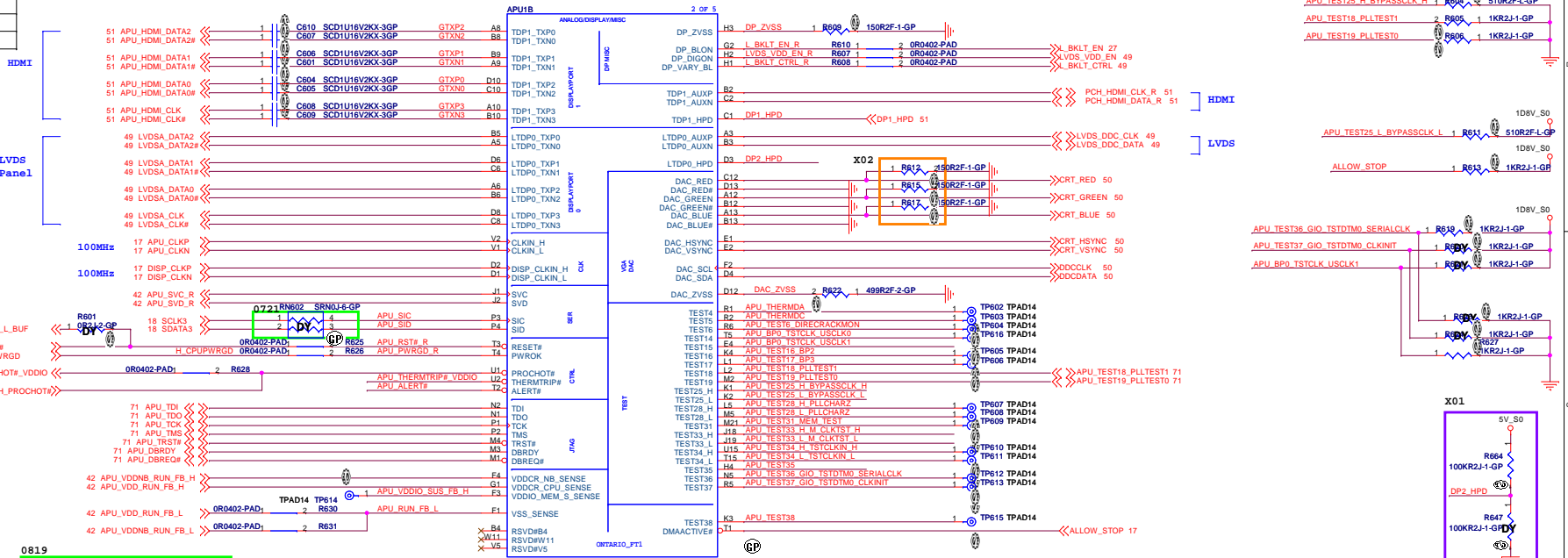

<Core Design>

Wistron Corporation
 21F, 88, Sec.1, Hsin Tai Wu Rd., Hsinchu, Taipei Hsein 221, Taiwan, R.O.C.

File: **APU_Control&Debug(3/5)**

Size: Document Number
 Custom: **Enrico 14 AMD**

Date: Friday, April 22, 2011 Sheet: 6 of 109 Rev: A00

SSID = CPU

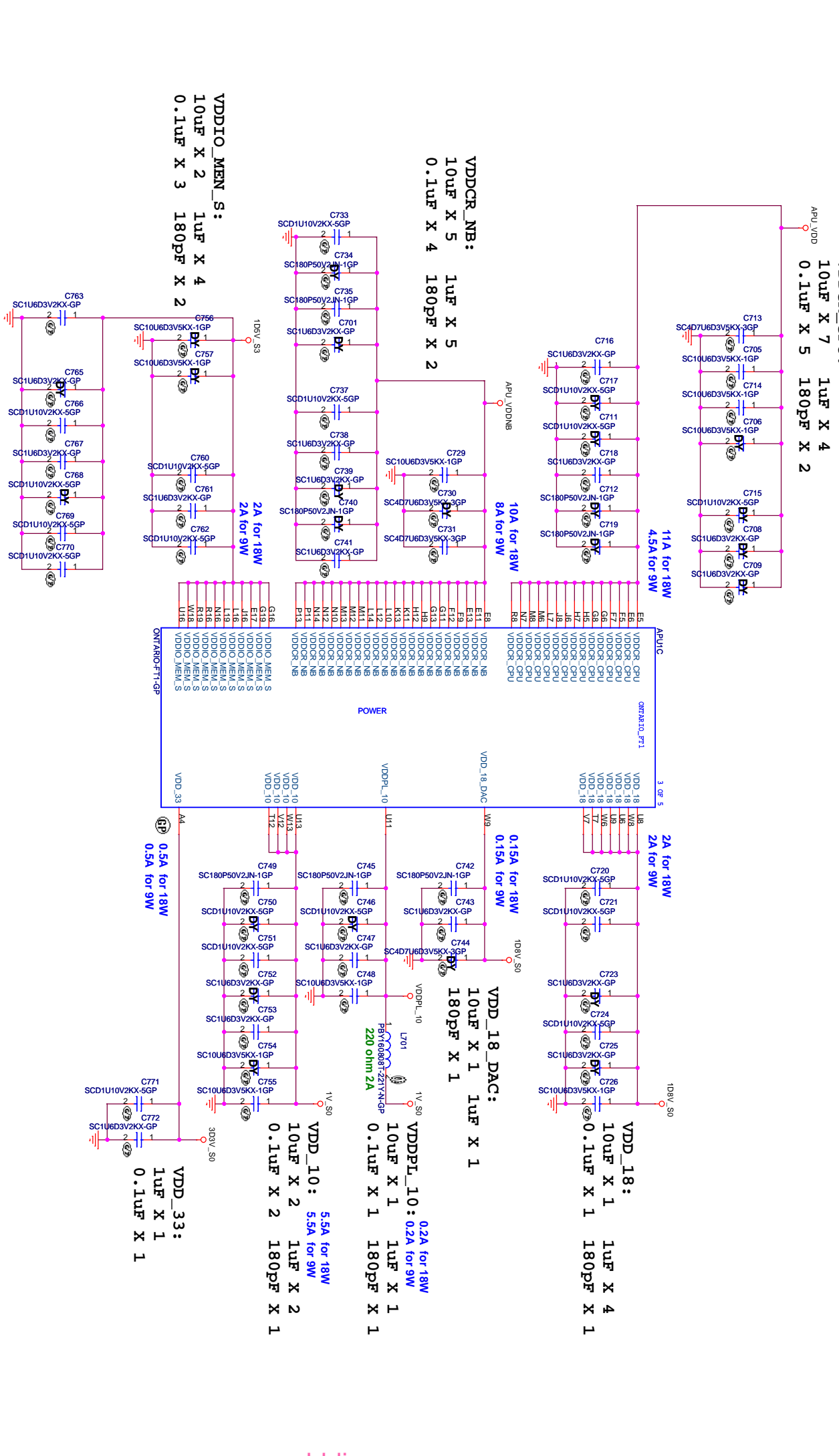

<Core Design>



Wistron Corporation
21F, 88, Sec 1, Hsin Tai Wu Rd., Hsichih,
Taipei Hsien 221, Taiwan, R.O.C.

Title: **APU Power(4/5)**

Size: A3	Document Number: Entico 14 AMD
Date: Friday, April 22, 2011	Sheet: 7 of 109
Rev: A00	

SSID = CPU

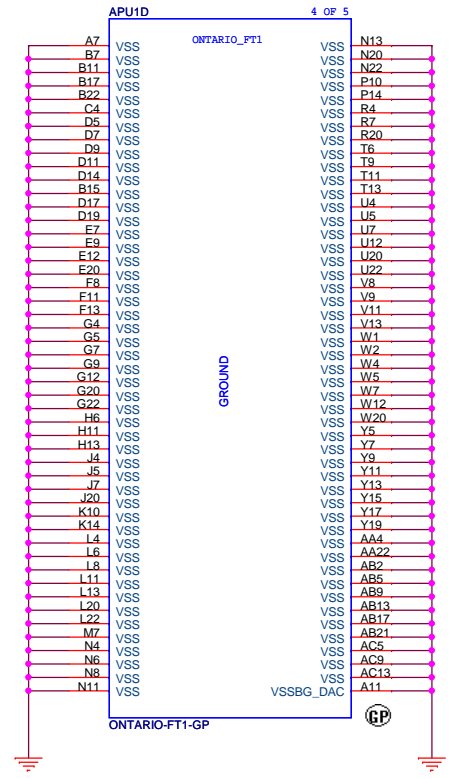

<Core Design>

		Wistron Corporation 21F, 88, Sec. 1, Hsin Tai Wu Rd., Hsichih, Taipei Hsien 221, Taiwan, R.O.C.
Title APU_VSS(5/5)		
Size A3	Document Number Enrico 14 AMD	Rev A00
Date: Friday, April 22, 2011	Sheet 8 of 109	

(Blanking)

<Core Design>

		Wistron Corporation 21F, 88, Sec.1, Hsin Tai Wu Rd., Hsichih, Taipei Hsien 221, Taiwan, R.O.C.	
Title TRAVIS			
Size A3	Document Number Enrico 14 AMD		Rev A00
Date: Friday, April 22, 2011	Sheet	9	of 109

(Blanking)

<Core Design>

		Wistron Corporation 21F, 88, Sec.1, Hsin Tai Wu Rd., Hsichih, Taipei Hsien 221, Taiwan, R.O.C.	
Title Reserved			
Size A3	Document Number Enrico 14 AMD		Rev A00
Date: Friday, April 22, 2011		Sheet 10	of 109

(Blanking)

<Core Design>

		Wistron Corporation 21F, 88, Sec.1, Hsin Tai Wu Rd., Hsichih, Taipei Hsien 221, Taiwan, R.O.C.	
Title		Reserved	
Size	Document Number	Rev	
A3	Enrico 14 AMD	A00	
Date:	Friday, April 22, 2011	Sheet	11 of 109

(Blanking)

<Core Design>

		Wistron Corporation 21F, 88, Sec.1, Hsin Tai Wu Rd., Hsichih, Taipei Hsien 221, Taiwan, R.O.C.	
Title		Reserved	
Size	Document Number	Rev	
A3	Enrico 14 AMD	A00	
Date:	Friday, April 22, 2011	Sheet	12 of 109

(Blanking)

<Core Design>

		Wistron Corporation 21F, 88, Sec.1, Hsin Tai Wu Rd., Hsichih, Taipei Hsien 221, Taiwan, R.O.C.	
Title		Reserved	
Size	Document Number	Rev	
A3	Enrico 14 AMD	A00	
Date:	Friday, April 22, 2011	Sheet	13 of 109

SSID = MEMORY

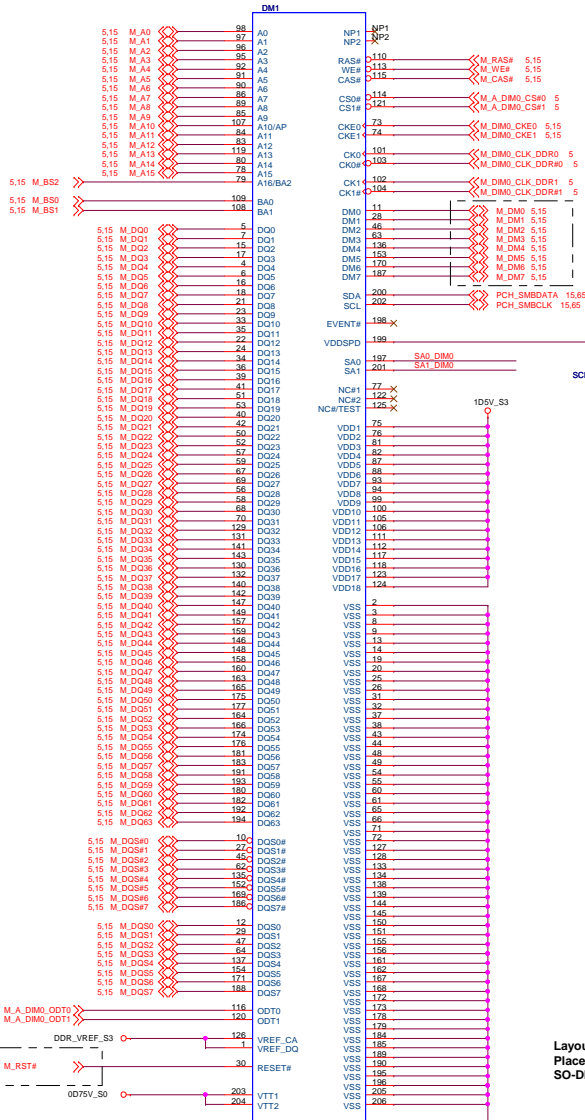
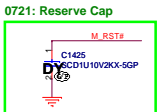
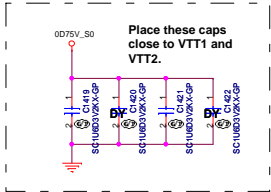
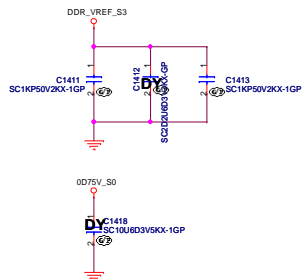

Intel HR DM tied to GND
AMD still following previous design

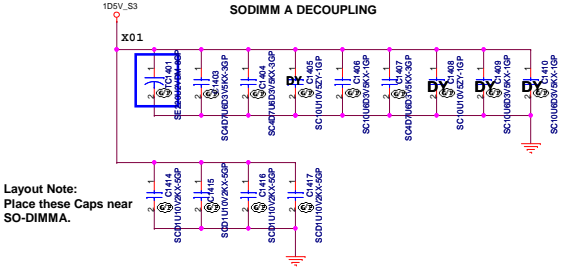
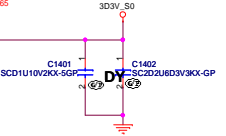

Layout Note:
Place these Caps near SO-DIMMA.

62.10017.K11
H=5.2mm

«Core Design»
DELL Wistron Corporation
21F, 88, Sec.1, Hsiao Tai Wu Rd., Hsuehchi,
Taipei Hsien 221, Taiwan, R.O.C.
Rev: **DDR3-SODIMM1**
Size: Document Number: **Enrico 14 AMD** Rev: **A00**
Date: Friday, April 22, 2011 Sheet 14 of 109

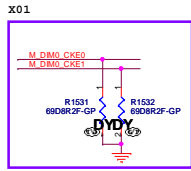

Intel HR DM tied to GND
AMD still following previous design

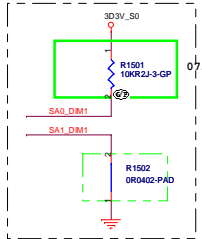

Intel HR B channel address is 01
AMD B channel address is 10

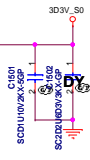

Layout Note:
Place these Caps near
SO-DIMMB.

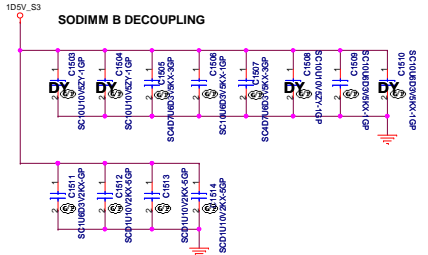

SO-DIMMB is placed farther from
the Processor than SO-DIMMA

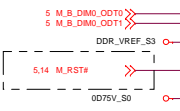
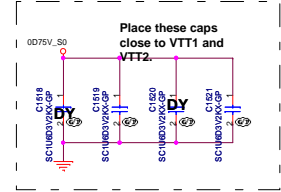
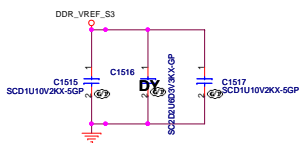

DDR3-204P-24-GP
62.10017.K01
H=9.2mm



<Core Design>



Title		Reserved	
Size	Document Number	Rev	
A3	Enrico 14 AMD	A00	
Date: Friday, April 22, 2011	Sheet 16	of	109

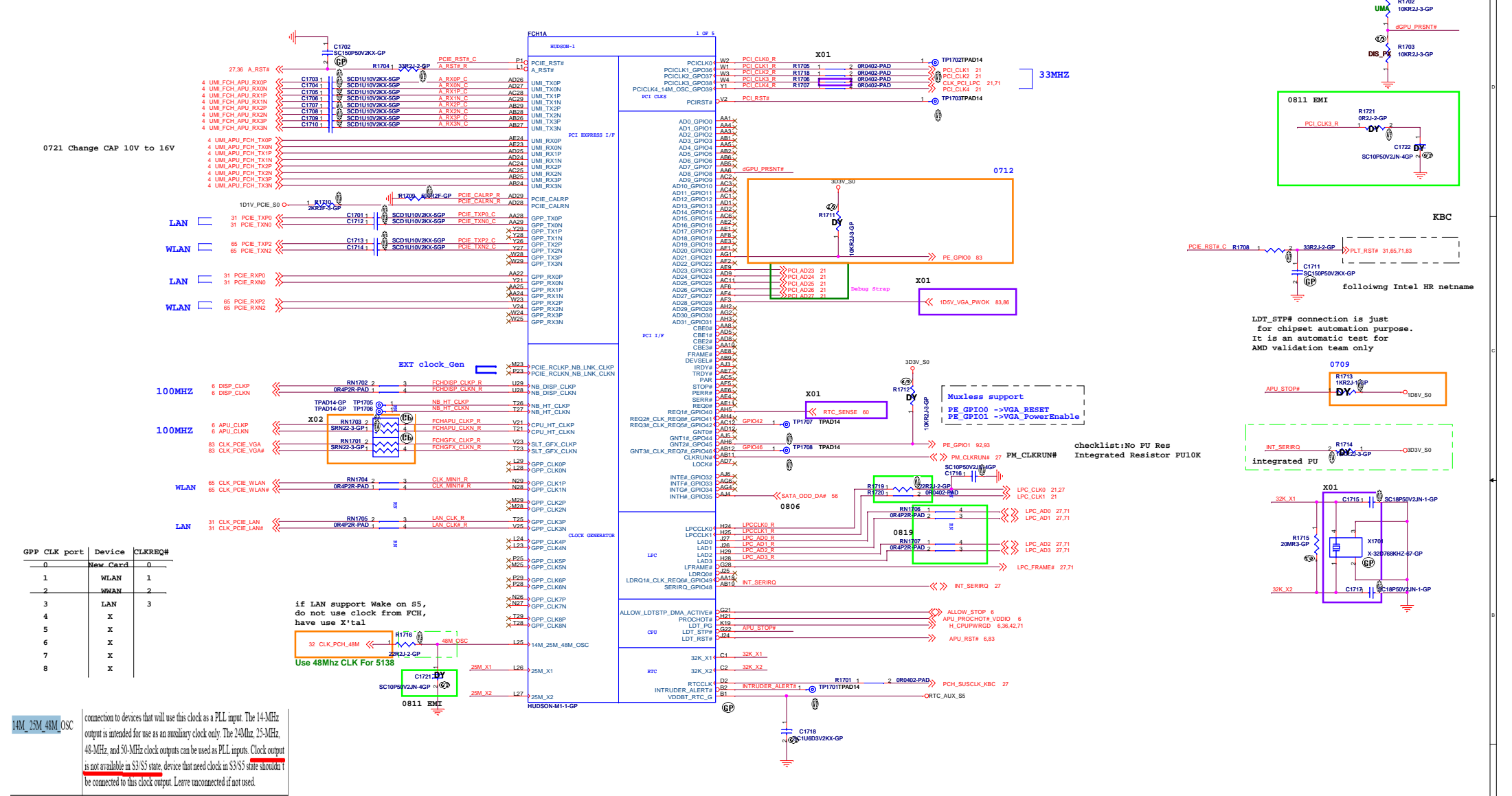

0721 Change CAP 10V to 16V

- LAN 31 PCIe_TXP0
- LAN 31 PCIe_TXN0
- WLAN 65 PCIe_TXP2
- WLAN 65 PCIe_TXN2
- LAN 31 PCIe_RXP0
- LAN 31 PCIe_RXN0
- WLAN 65 PCIe_RXP2
- WLAN 65 PCIe_RXN2

- 100MHZ 6 DISP_CLKP
- 100MHZ 6 DISP_CLKN
- 100MHZ 6 APU_CLKP
- 100MHZ 6 APU_CLKN
- 83 CLK_PCIE_VGA
- 83 CLK_PCIE_VGA#
- WLAN 65 CLK_PCIE_WLAN
- WLAN 65 CLK_PCIE_WLAN#
- LAN 31 CLK_PCIE_LAN
- LAN 31 CLK_PCIE_LAN#

GPP CLK port	Device	CLKREQ#
0	New Card	0
1	WLAN	1
2	WLAN	2
3	LAN	3
4	X	
5	X	
6	X	
7	X	
8	X	

14M_25M_48M_OSC connection to devices that will use this clock as a PLL input. The 14-MHz output is intended for use as an auxiliary clock only. The 2.4Mhz, 25-MHz, 48-MHz, and 50-MHz clock outputs can be used as PLL inputs. Clock output is not available in S3/S5 state; device that need clock in S3/S5 state should not be connected to this clock output. Leave unconnected if not used.

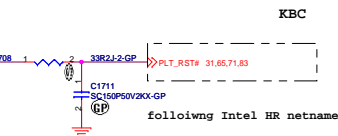
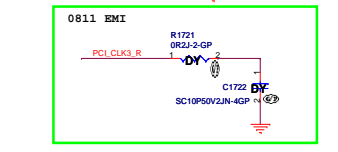
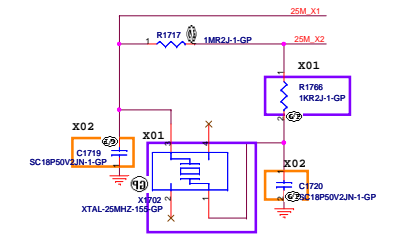

following Intel HR netname

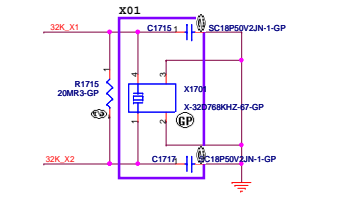
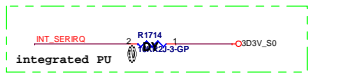

SSID = FCH

Integrated PU is not supported when the pin is configured for USB over current function.

0720: Change From 2.2K and POP

Confirm with SW, RSMRST# from KBC is push-pull. It can be driven high by SW.

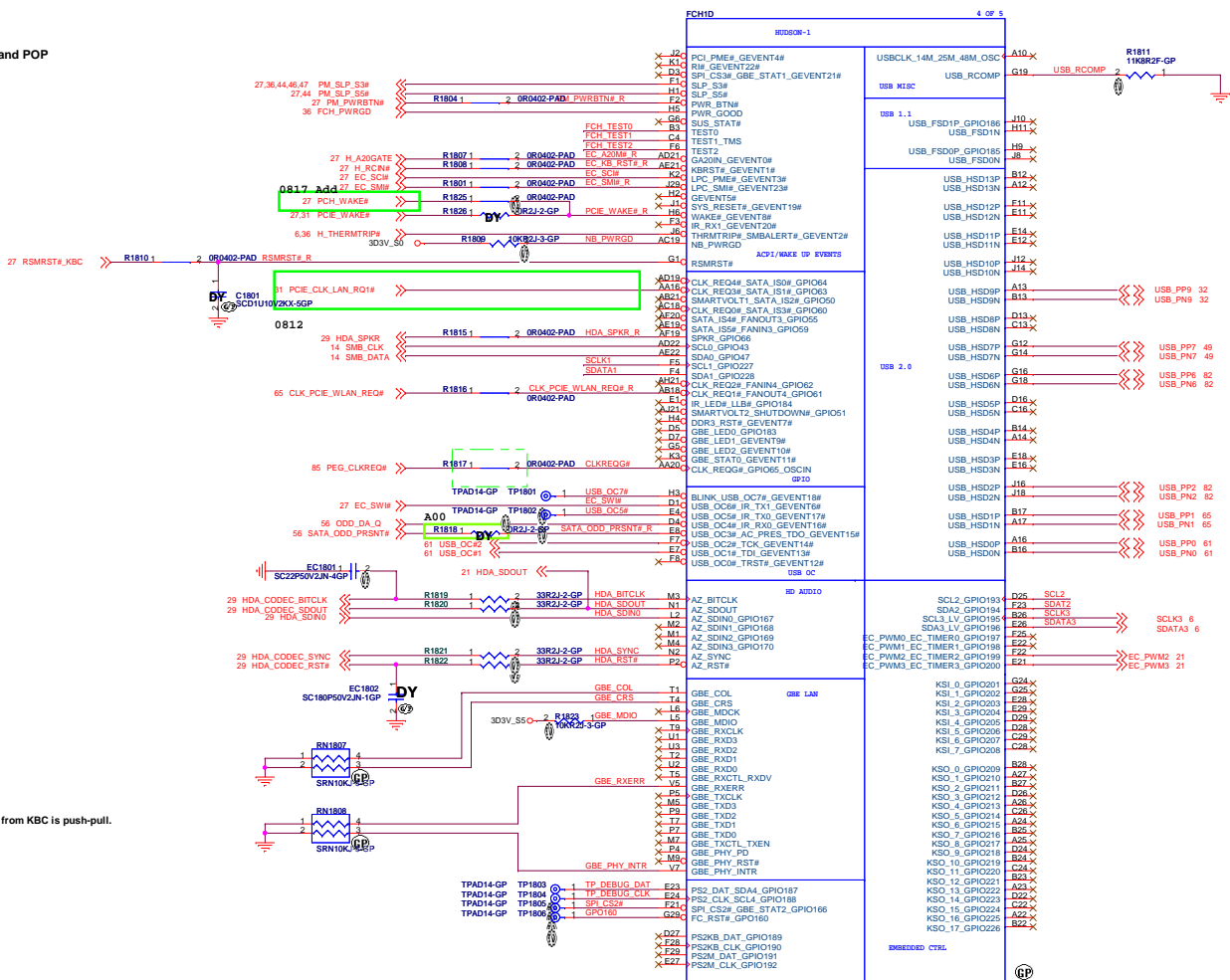
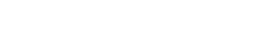
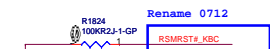
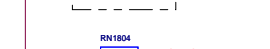
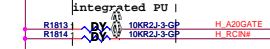
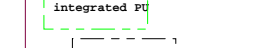
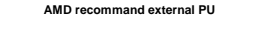
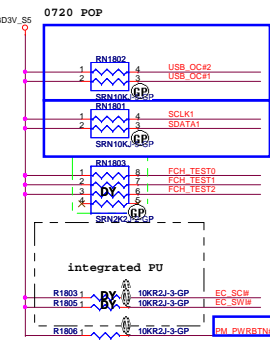

Pair	USB Device
0	USB 2.0 EXT.Port1
1	Mini Card1 (WLAN)
2	USB 2.0 EXT.Port1
3	NC
4	NC
5	NC
6	USB 2.0 EXT.Port1
7	CCD Camera
8	NEWCARD
9	Card Reader
10	NC
11	NC
12	NC
13	NC

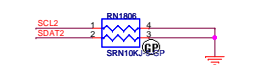

if not used SMBUS or GPIO, PD 10K

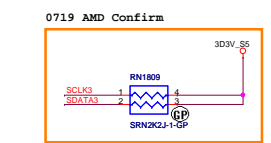

0719 AMD Confirm

©Core Design

DELL Wistron Corporation
21F, 8B, Sec. 1, Hsin Tai Wu Rd., Hsinchu, Taipei Hsin 221, Taiwan, R.O.C.

File # **HUDSON-M2(2/6)**

Size Document Number **Enrico 14 AMD** Rev **A00**

Date: Friday, April 22, 2011 Sheet 18 of 18

SSID = FCH

0721 Change CAP to 10n

FCH1B 2 OF 5

SATA HDD
SATA ODD

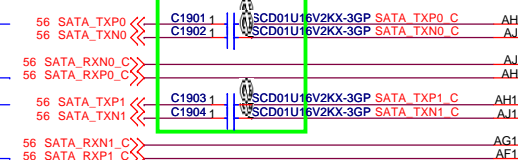

PLACE SATA AC DECOUPLING CAPS CLOSE TO FCH

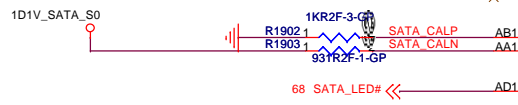

[checklist]:integrated Clock Mode=>Left unconnected

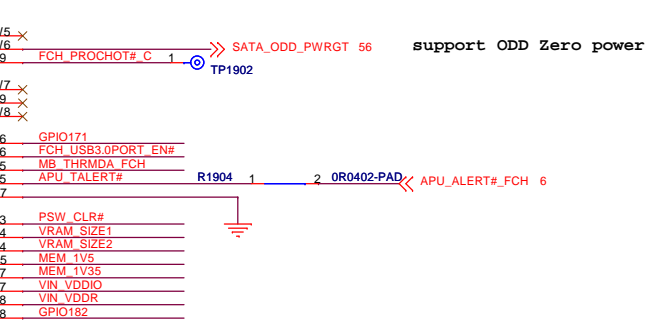
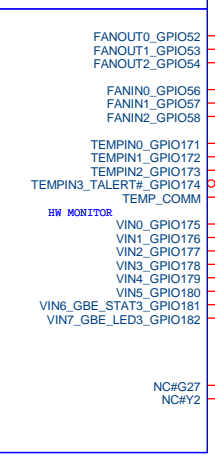
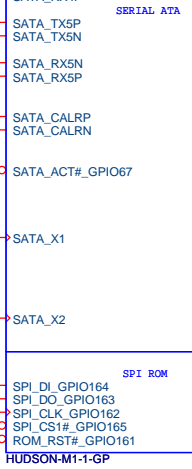
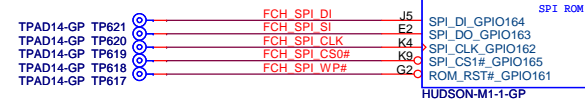

GPIO[150:128] are open drain GPIO pins where as GPO160 is an open drain GPO pin. These pins are not programmed to GPIO mode by default.

If use as GPIO, need to pull up to 1.8V_RUN

support ODD Zero power

VDDIO	MEM_1V35	MEM_1V35
1.5V	H	Don't Care
1.35V	L	H

XTAL
1'nd 82.30020.851
2'nd 82.30020.791

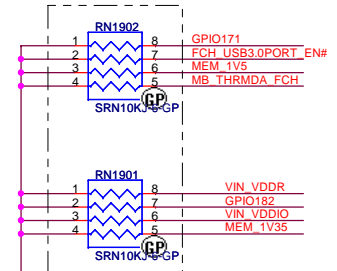

if not used HWM or GPIO ,PD 10K

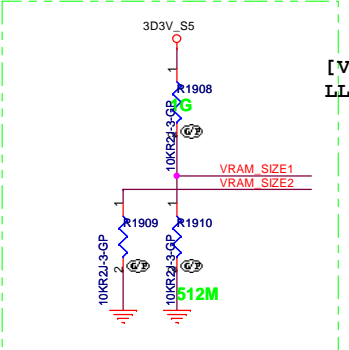

[VRAM_SIZE1:VRAM_SIZE2]
LL=512M / HL=1G / LH=2G

<Core Design>

Wistron Corporation
21F, 88, Sec.1, Hsin Tai Wu Rd., Hsichih, Taipei Hsien 221, Taiwan, R.O.C.

Title: **HUDSON-M1 SATA/HWM/SPI(3/6)**

Size: Document Number
Enrico 14 AMD

Date: Friday, April 22, 2011 Sheet 19 of 109

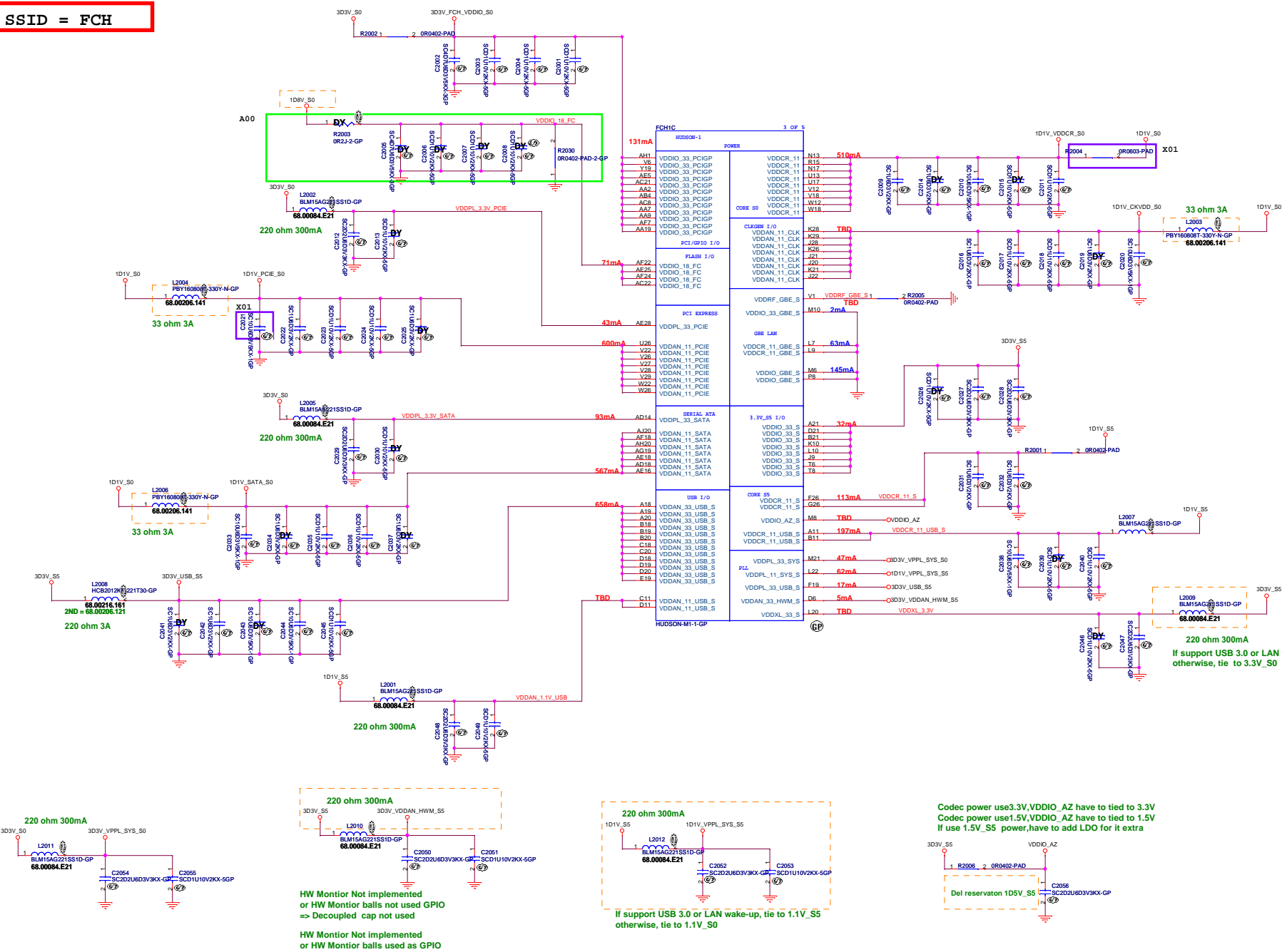

If support USB 3.0 or LAN wake-up, pls tie to 3.3V_S5 otherwise, tie to 3.3V_S0

HW Monitor Not implemented or HW Monitor balls not used GPIO => Decoupled cap not used

HW Monitor Not implemented or HW Monitor balls used as GPIO => Bead not used

If support USB 3.0 or LAN wake-up, tie to 1.1V_S5 otherwise, tie to 1.1V_S0

Codec power use 3.3V, VDDIO_AZ have to tied to 3.3V
Codec power use 1.5V, VDDIO_AZ have to tied to 1.5V
If use 1.5V_S5 power, have to add LDO for it extra

Core Design

DELL Wistron Corporation
21F, 8B, Sec. 1, Hsin Tai Wu Rd., Hsinchu, Taipei Hsein 221, Taiwan, R.O.C.

File: **HUDSON-M1 Power(4/6)**

Size: A2 Document Number: **Enrico 14 AMD** Rev: **A00**

Date: Friday, April 22, 2011 Sheet: 20 of 108

SSID = FCH

REQUIRED STRAPS

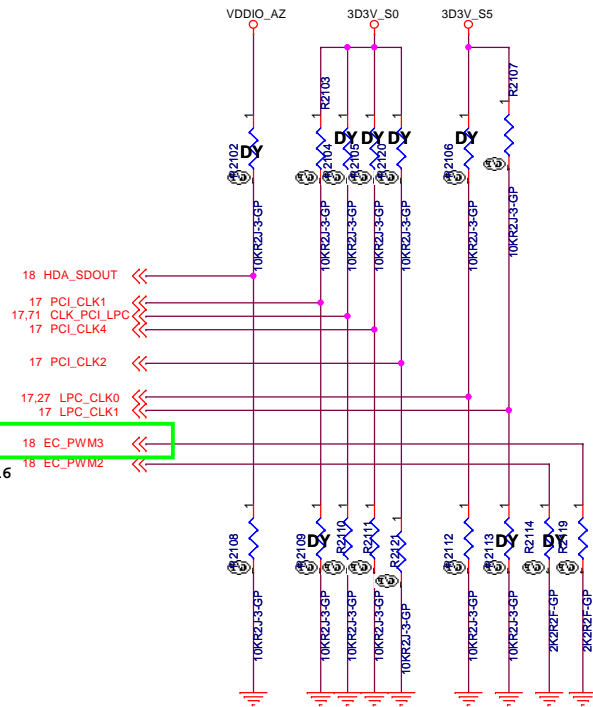

REQUIRED SYSTEM STRAPS

	AZ_SDOUT	PCI_CLK1	CLK_PCI_LPC	PCI_CLK4	LPC_CLK0	LPC_CLK1	LPC_CLK2
PULL HIGH	LOW POWER MODE	Allow PCIE GEN2 DEFAULT	USE DEBUG STRAPS	non_Fusion CLOCK mode	ENABLE EC	CLKGEN ENABLED (Use Internal) DEFAULT	Enable boot timer function
PULL LOW	PERFORMANCE MODE DEFAULT	Force PCIE GEN1	IGNORE DEBUG STRAPS DEFAULT	Fusion CLOCK mode DEFAULT	DISABLE EC DEFAULT	CLKGEN DISABLED (Use External)	Disable boot fail timer function DEFAULT

TYPE ENABLED	EC_PWM2	EC_PWM3
Reserved	2.2-kohm 5% pull-down	2.2-kohm 5% pull-down
LPC ROM	Not connected.	2.2-kohm 5% pull-down
SPI ROM	2.2-kohm 5% pull-down	Not connected.
Reserved	Not connected.	Not connected.

Note: EC_PWM2, EC_PWM3 default have internal 10kohm PU.

DEBUG STRAPS

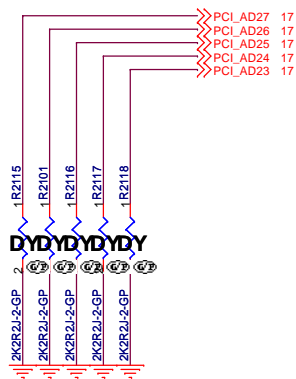

	PCI_AD27	PCI_AD26	PCI_AD25	PCI_AD24	PCI_AD23
PULL HIGH	USE PCI PLL (DEFAULT)	Disable ILA AUTORUN (DEFAULT)	USE FC PLL (DEFAULT)	USE DEFAULT PCIE STRAPS (DEFAULT)	Disable PCI MEM BOOT (DEFAULT)
PULL LOW	BYPASS PCI PLL	Enable ILA AUTORUN	BYPASS FC PLL	USE EEPROM PCIE STRAPS	Enable PCI MEM BOOT

Note: FCH has 15K internal PU FOR PCI_AD[27:23]

<Core Design>

DELL		Wistron Corporation	
		21F, 88, Sec.1, Hsin Tai Wu Rd., Hsichih, Taipei Hsien 221, Taiwan, R.O.C.	
Title HUDSON_STRAPPING_(5/6)			
Size A3	Document Number Enrico 14 AMD	Rev A00	
Date: Friday, April 22, 2011	Sheet 21	of 109	

SSID = FCH

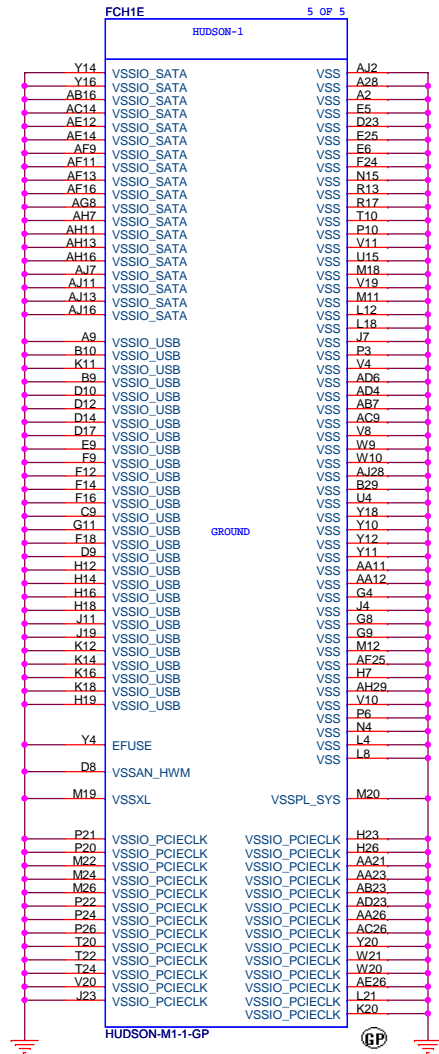

<Core Design>

Wistron Corporation
21F, 88, Sec.1, Hsin Tai Wu Rd., Hsichih,
Taipei Hsien 221, Taiwan, R.O.C.

Title Reserved		
Size A3	Document Number Enrico 14 AMD	Rev A00
Date: Friday, April 22, 2011	Sheet 22 of	109

(Blanking)

<Core Design>

			Wistron Corporation 21F, 88, Sec.1, Hsin Tai Wu Rd., Hsichih, Taipei Hsien 221, Taiwan, R.O.C.		
Title					
Reserved					
Size	Document Number				Rev
A3	Enrico 14 AMD				A00
Date: Friday, April 22, 2011			Sheet 23 of 109		

(Blanking)

<Core Design>

		Wistron Corporation 21F, 88, Sec.1, Hsin Tai Wu Rd., Hsichih, Taipei Hsien 221, Taiwan, R.O.C.	
Title		Reserved	
Size A3	Document Number	Enrico 14 AMD	Rev A00
Date: Friday, April 22, 2011	Sheet 24	of	109

(Blanking)

<Core Design>

		Wistron Corporation 21F, 88, Sec.1, Hsin Tai Wu Rd., Hsichih, Taipei Hsien 221, Taiwan, R.O.C.	
Title			
Reserved			
Size	Document Number	Rev	
A3			A00
Date: Friday, April 22, 2011		Sheet	25 of 109

(Blanking)

<Core Design>

		Wistron Corporation 21F, 88, Sec.1, Hsin Tai Wu Rd., Hsichih, Taipei Hsien 221, Taiwan, R.O.C.	
Title		Reserved	
Size A3	Document Number	Enrico 14 AMD	Rev A00
Date: Friday, April 22, 2011	Sheet 26	of	109

SSID = KBC

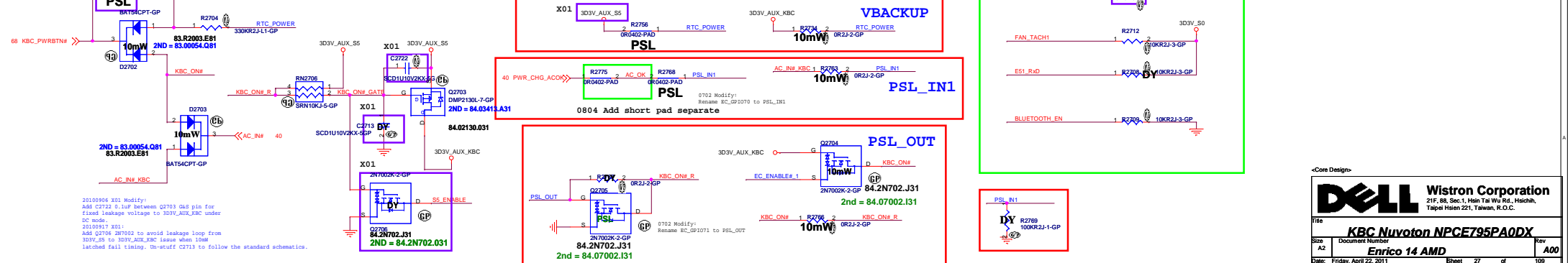
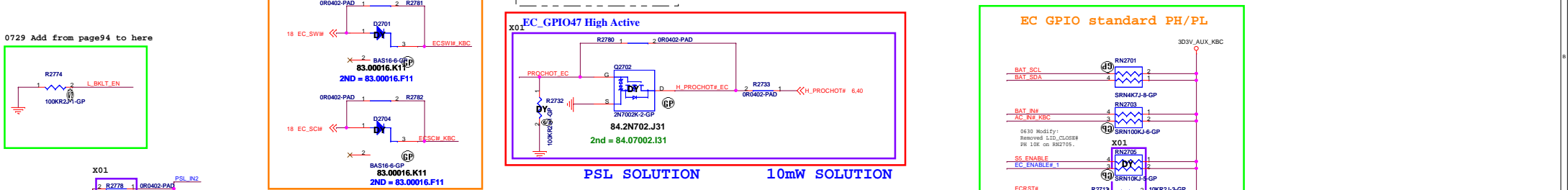
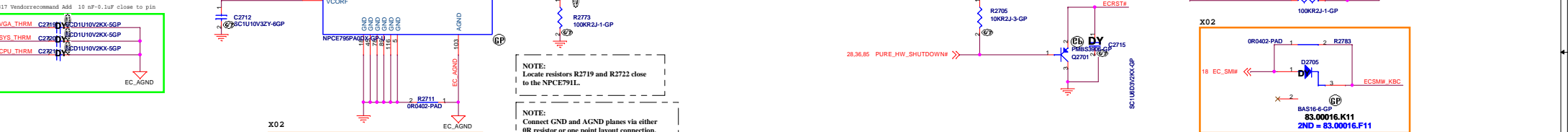
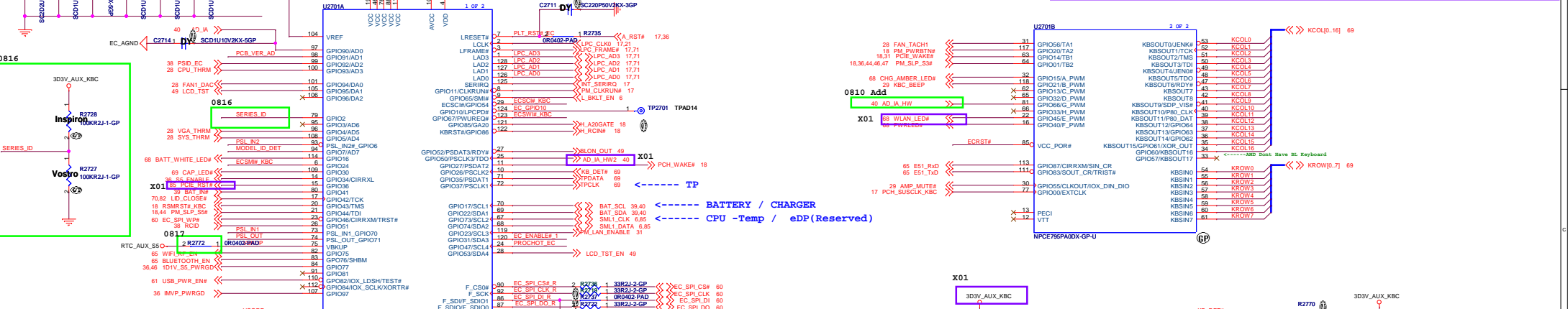
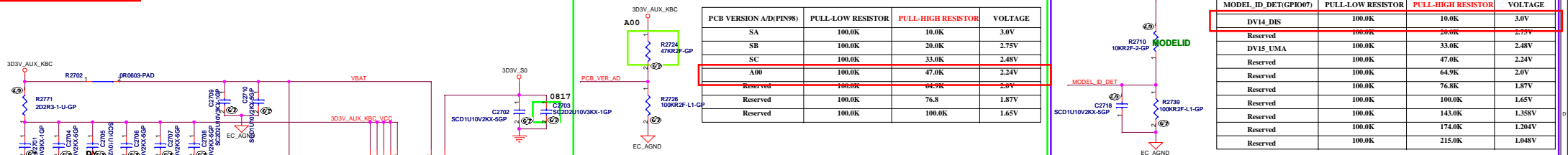

SSID = Thermal

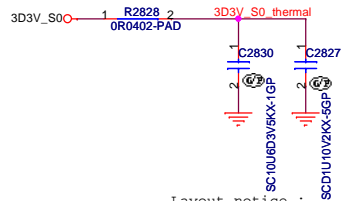

Layout notice :
Both DXN and DXP routing 10 mil trace width and 10 mil spacing.

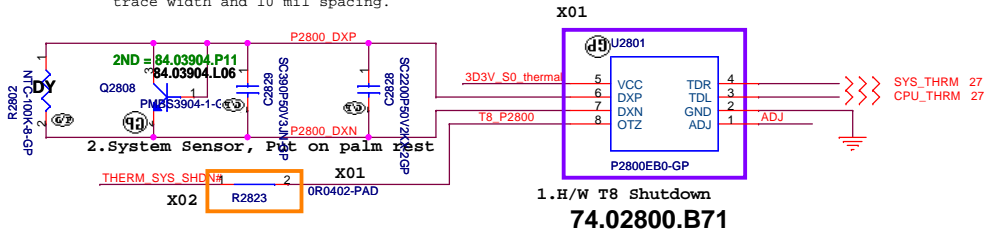

ADJ floating : OTZ shutdown temperature=85°C
ADJ pull-down : OTZ shutdown temperature=90°C
ADJ pull-up : OTZ shutdown temperature=95°C

Fan controller P2793

0721 Pull-down: full speed, R2830 dummy.

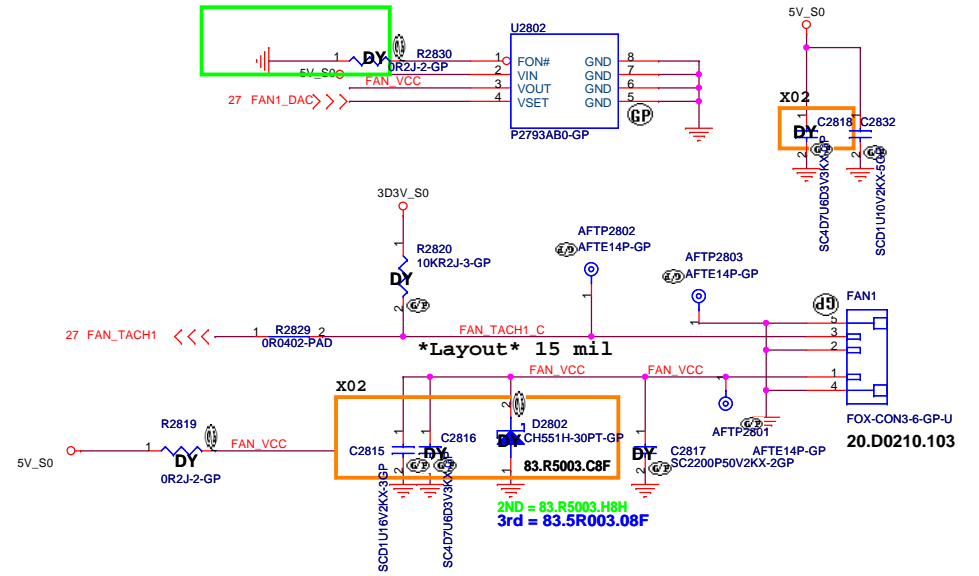

X02

VGA Thermal sensor P2800

Layout notice :
Both DXN and DXP routing 10 mil trace width and 10 mil spacing.

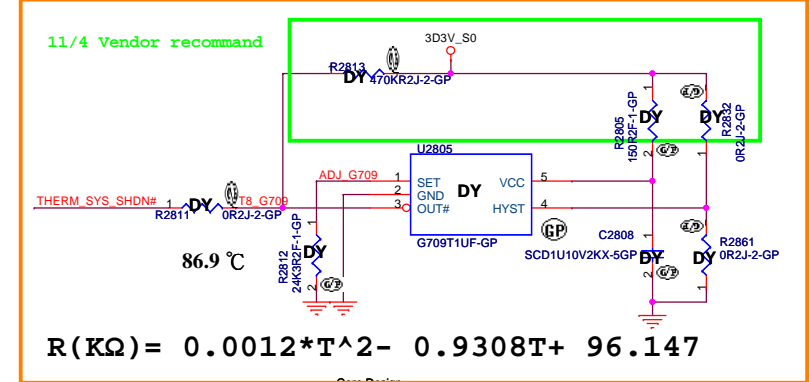
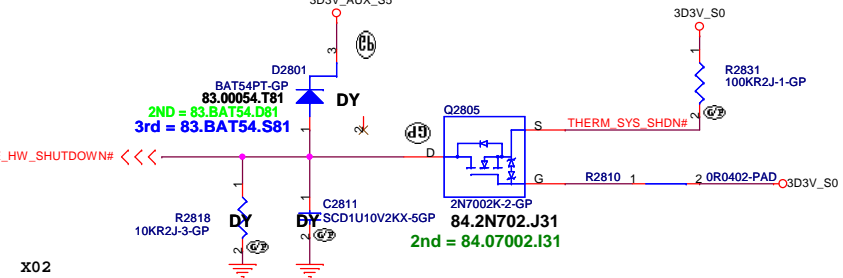
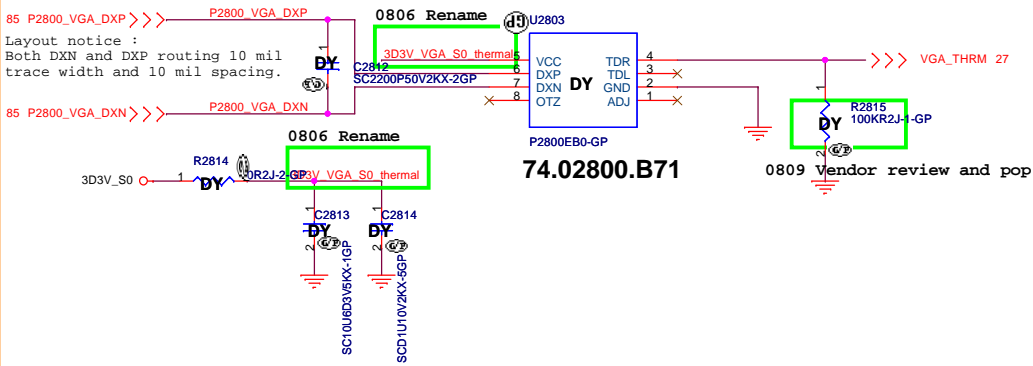

$$R(K\Omega) = 0.0012 * T^2 - 0.9308T + 96.147$$

DELL Wistron Corporation
 21F, 88, Sec.1, Hsin Tai Wu Rd., Hsieh, Taipei Hsien 221, Taiwan, R.O.C.

Title: **Thermal/Fan Controller EMC2102**
 Size: A3 Document Number: **Enrico 14 AMD** Rev: **A00**
 Date: Friday, April 22, 2011 Sheet 28 of 109

SSID = AUDIO

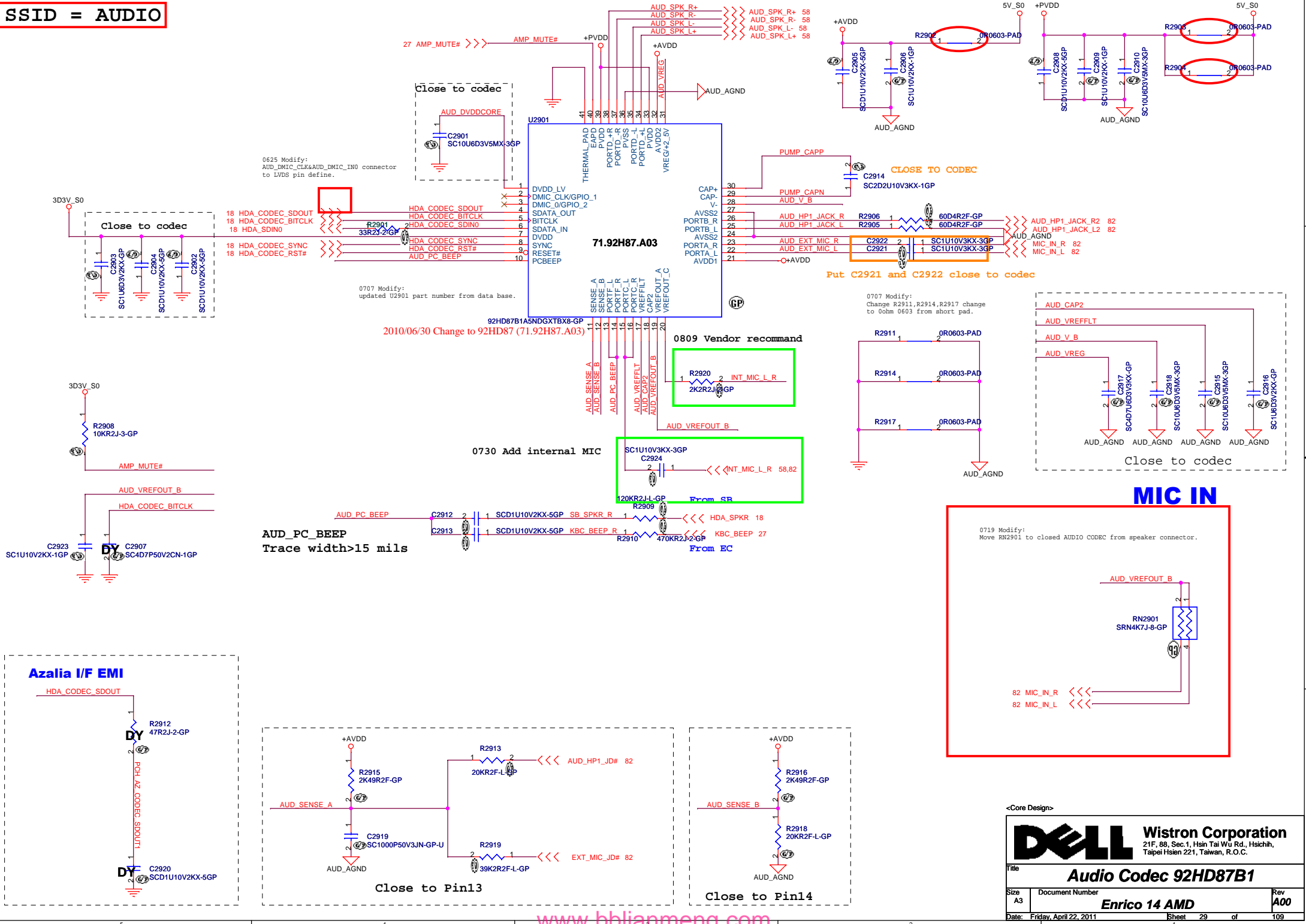

0625 Modify:
AUD_DMIC_CLK&AUD_DMIC_IN0 connector
to LVDS pin define.

0707 Modify:
updated U2901 part number from data base.

2010/06/30 Change to 92HD87 (71.92H87.A03)

0707 Modify:
Change R2911, R2914, R2917 change to
0ohm 0603 from short pad.

0719 Modify:
Move RN2901 to closed AUDIO CODEC from speaker connector.

Azalia I/F EMI

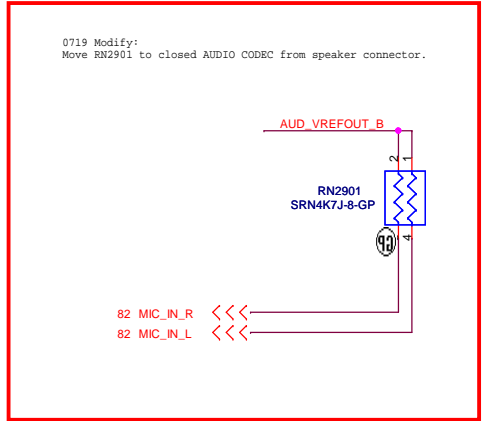
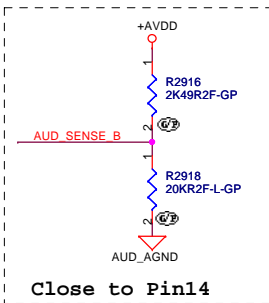
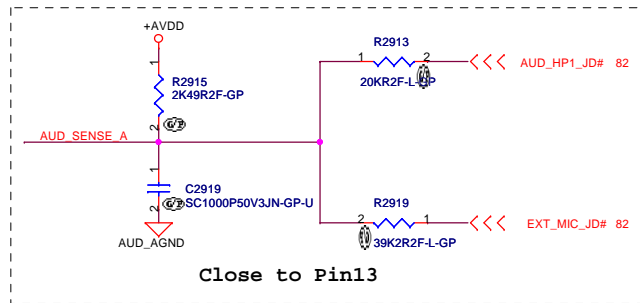

<Core Design>

DELL Wistron Corporation
21F, 88, Sec. 1, Hsin Tai Wu Rd., Hsichih,
Taipei Hsien 221, Taiwan, R.O.C.

Title: **Audio Codec 92HD87B1**

Size A3	Document Number	Rev A00
Enrico 14 AMD		
Date: Friday, April 22, 2011	Sheet 29	of 109



<Core Design>

		Wistron Corporation 21F, 88, Sec.1, Hsin Tai Wu Rd., Hsichih, Taipei Hsien 221, Taiwan, R.O.C.	
Title			
AMP			
Size	Document Number	Rev	
A3	Enrico 14 AMD	A00	
Date:	Friday, April 22, 2011	Sheet	30 of 109

SSID = LOM

LAN CHIP

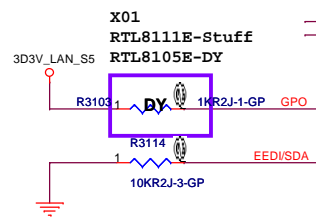
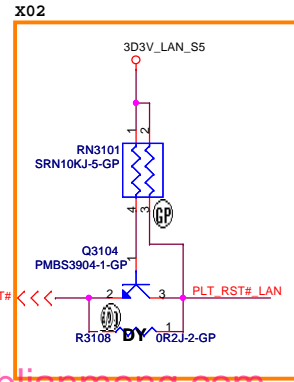
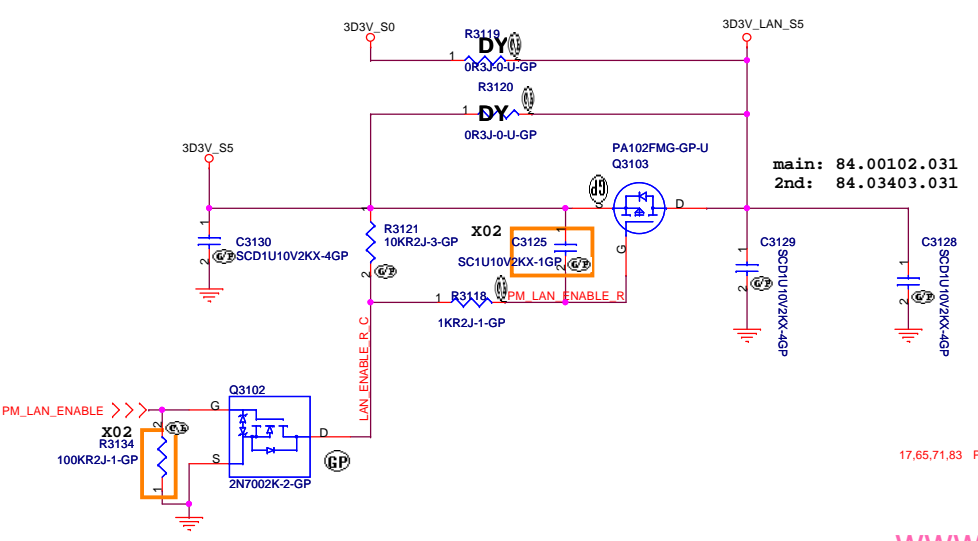
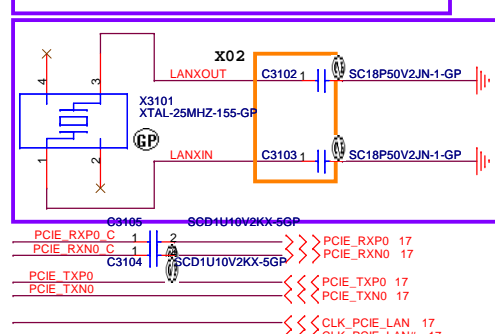
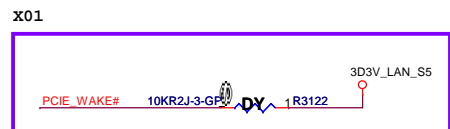
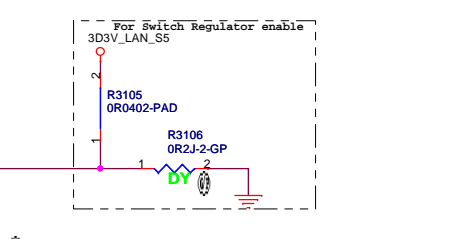
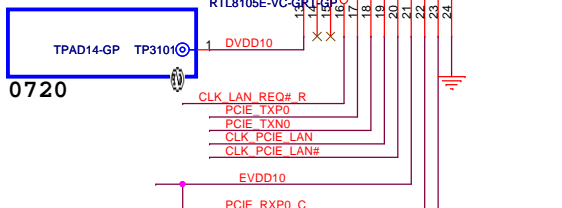
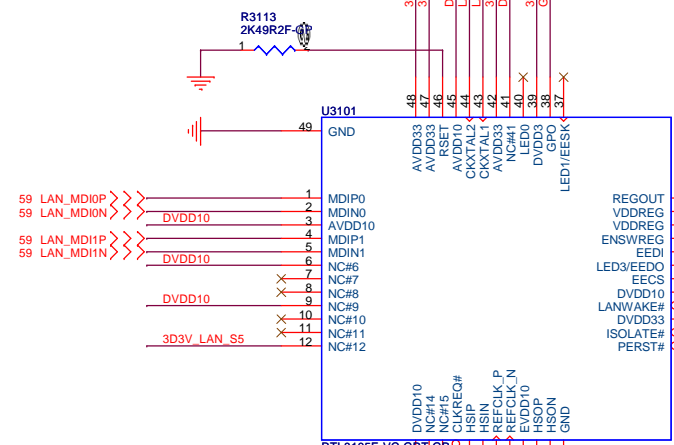
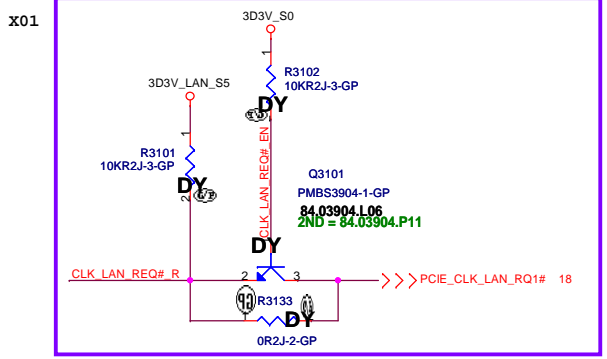
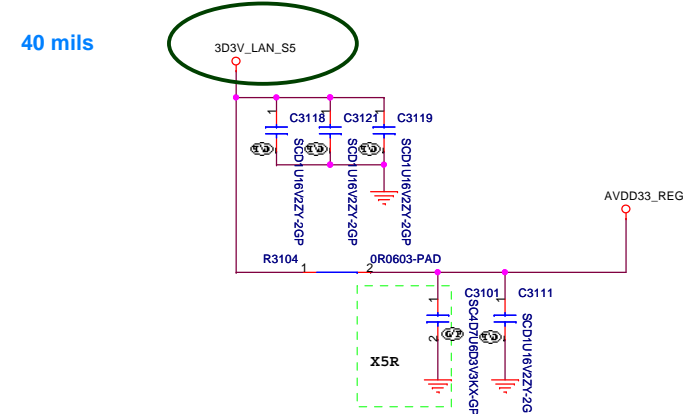
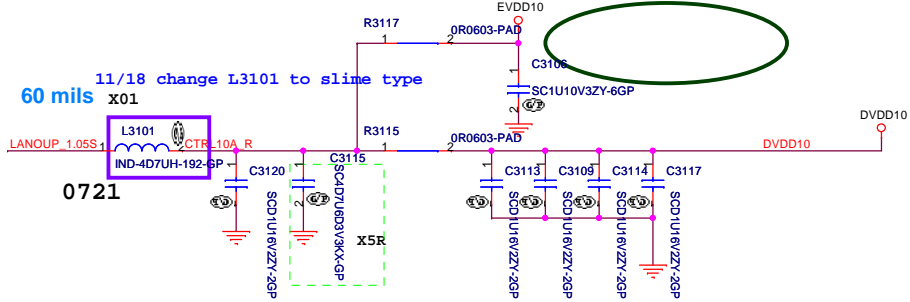

<Core Design>

Wistron Corporation
21F, 88, Sec. 1, Hsin Tai Wu Rd., Hsichih, Taipei Hsien 221, Taiwan, R.O.C.

Title: **LOM**

Size: A3	Document Number: Enrico 14 AMD	Rev: A00
Date: Friday, April 22, 2011	Sheet: 31	of: 109

SSID = SDIO

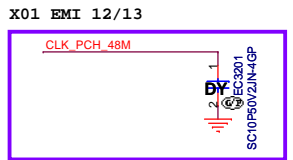
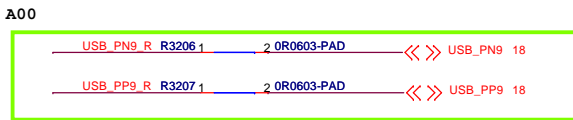
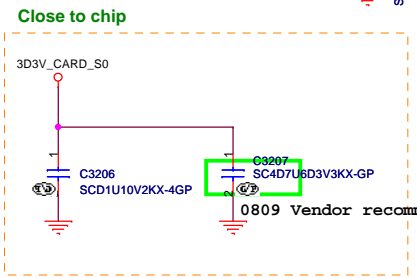
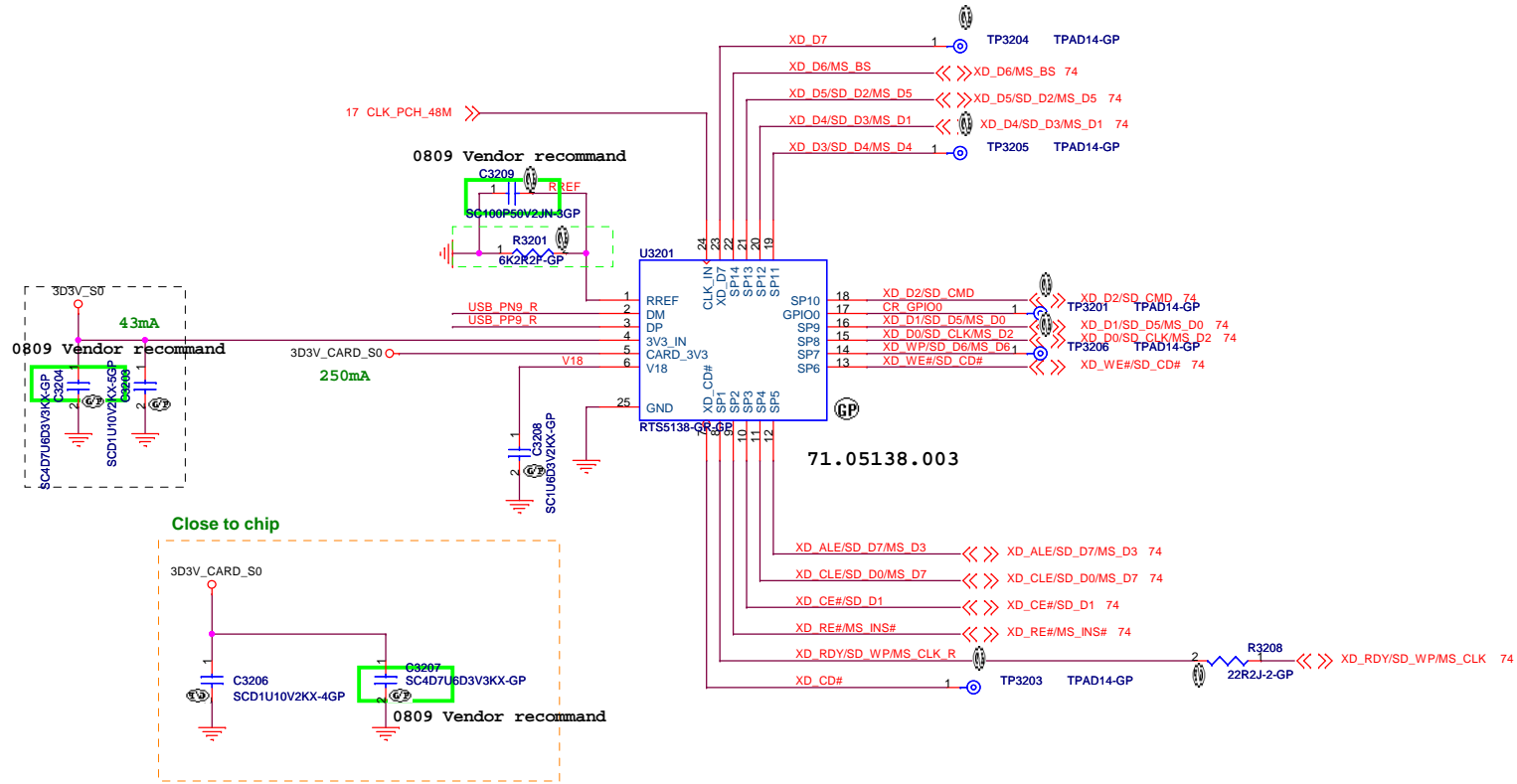

<Core Design>

Wistron Corporation
21F, 88, Sec.1, Hsin Tai Wu Rd., Hsichih,
Taipei Hsien 221, Taiwan, R.O.C.

Title: **Reserved**

Size: A3 Document Number: **Enrico 14 AMD** Rev: **A00**

Date: Friday, April 22, 2011 Sheet 32 of 109

(Blanking)

<Core Design>



Title		
Reserved		
Size A3	Document Number Enrico 14 AMD	Rev A00
Date: Friday, April 22, 2011	Sheet 33	of 109

(Blanking)

<Core Design>

		Wistron Corporation 21F, 88, Sec.1, Hsin Tai Wu Rd., Hsichih, Taipei Hsien 221, Taiwan, R.O.C.
Title		
Reserved		
Size A3	Document Number Enrico 14 AMD	Rev A00
Date: Friday, April 22, 2011	Sheet 34	of 109

(Blanking)

<Core Design>

		Wistron Corporation 21F, 88, Sec. 1, Hsin Tai Wu Rd., Hsichih, Taipei Hsien 221, Taiwan, R.O.C.
Title		
Reserved		
Size A3	Document Number Enrico 14 AMD	Rev A00
Date: Friday, April 22, 2011	Sheet 35 of 109	

ROSA Run Power

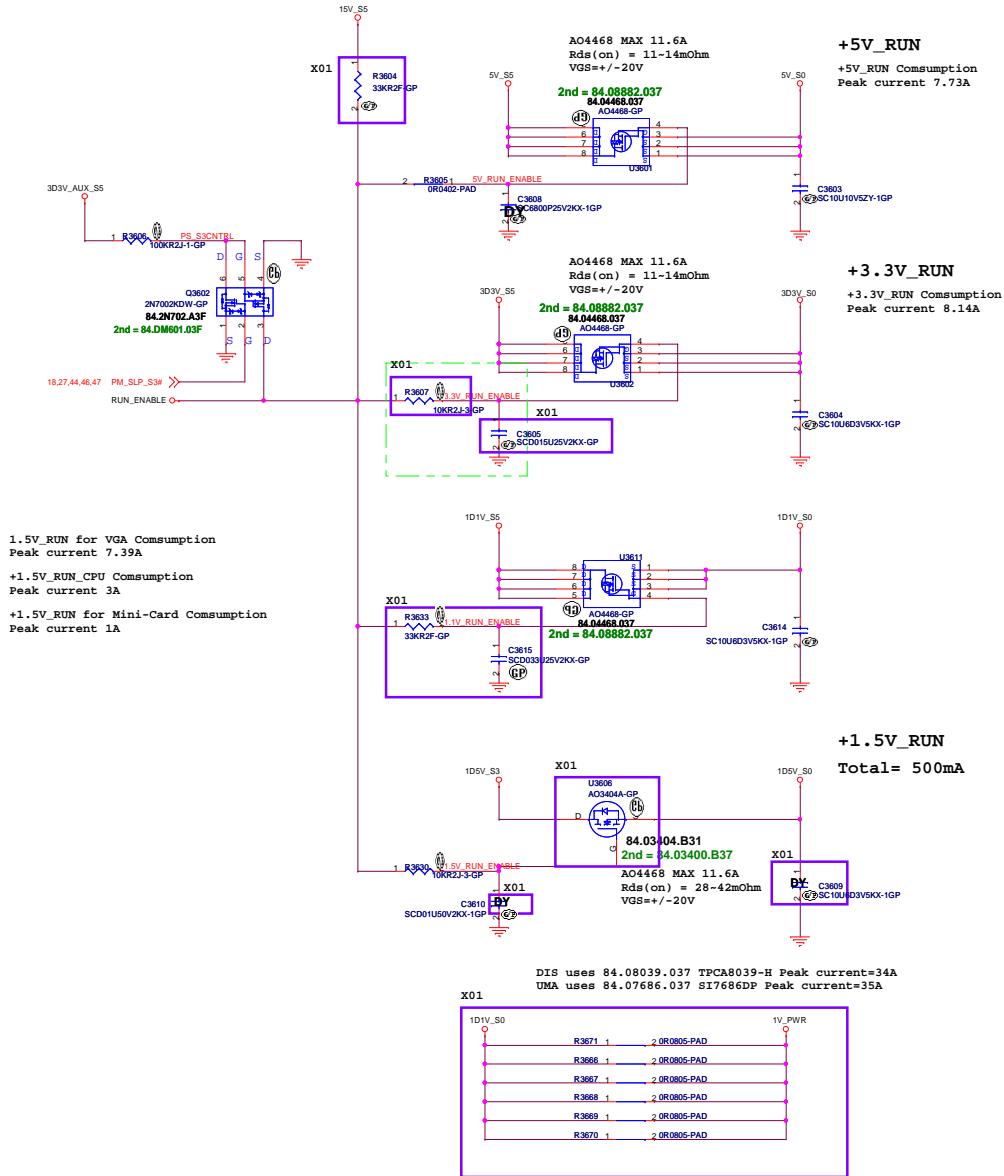

Power Sequence

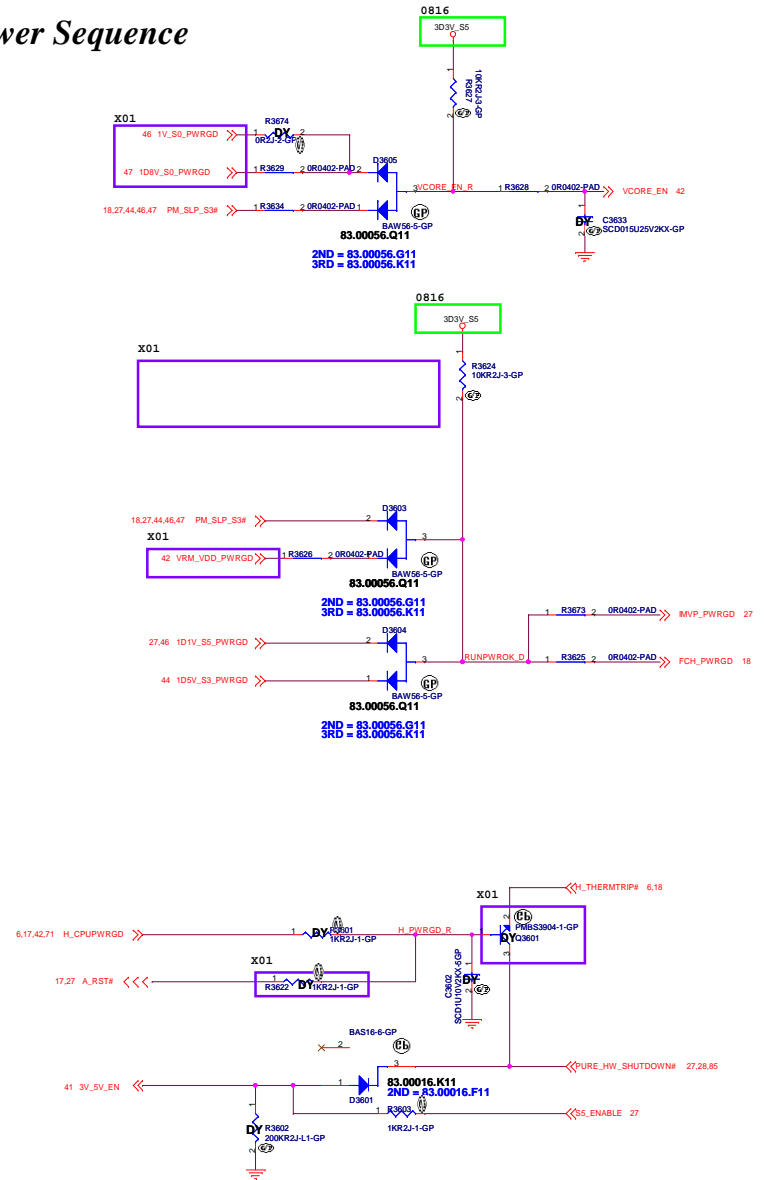

<Core Design>

DELL Wistron Corporation
21F, 88, Sec.1, Hsin Tai Wu Rd., Hsinchu, Taipei Hsein 221, Taiwan, R.O.C.

File **Power On Logic**

Size Document Number **Enrico 14 AMD** Rev **A00**

Date: Friday, April 22, 2011 Sheet 36 of 108

5

4

3

2

1

D

D

C

C

B

B

A

A

<Core Design>

		Wistron Corporation 21F, 88, Sec.1, Hsin Tai Wu Rd., Hsichih, Taipei Hsien 221, Taiwan, R.O.C.	
Title Power Plane Enable			
Size A3	Document Number Enrico 14 AMD	Rev A00	
Date: Friday, April 22, 2011	Sheet 37	of	109

5

4

3

2

1

SSID = PWR.Support

DCin CONN

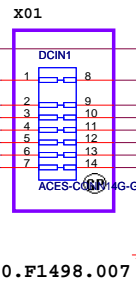
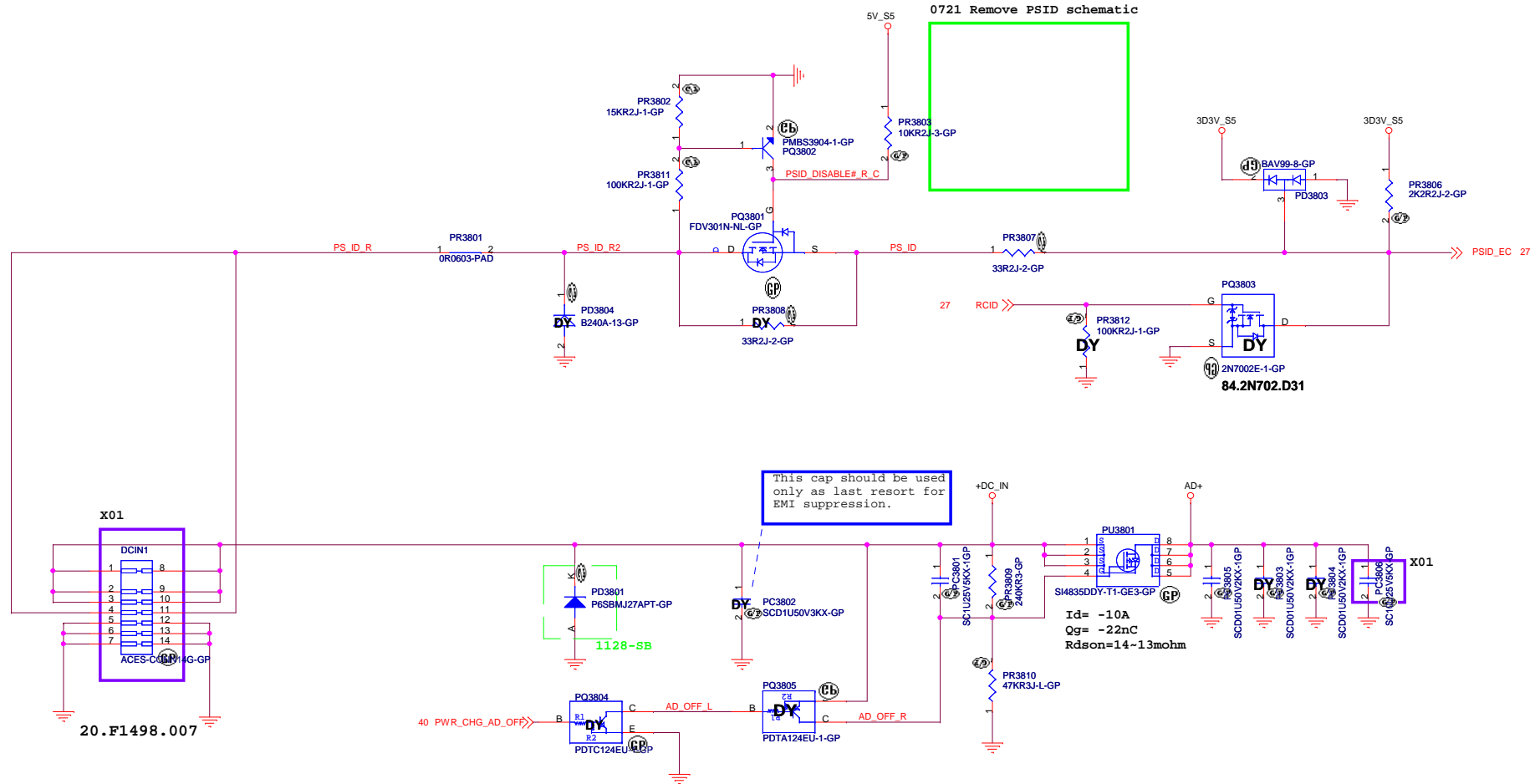

- AFTP3812 ① 1 PS_ID_R
- AFTP3813 ① 1 +DC_IN
- AFTP3814 ① 1 GND

This cap should be used only as last resort for EMI suppression.

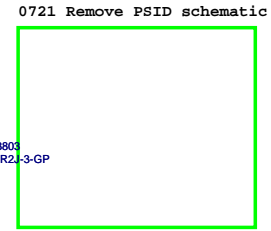

<Core Design>

DELL Wistron Corporation
21F, 88, Sec.1, Hsin Tai Wu Rd., Hsichih,
Taipei Hsien 221, Taiwan, R.O.C.

Title: **DCIN JACK**

Size	Document Number	Rev
Custom	Enrico 14 AMD	A00
Date: Friday, April 22, 2011	Sheet 38 of	109

SSID = BATT CONN

Batt Connector

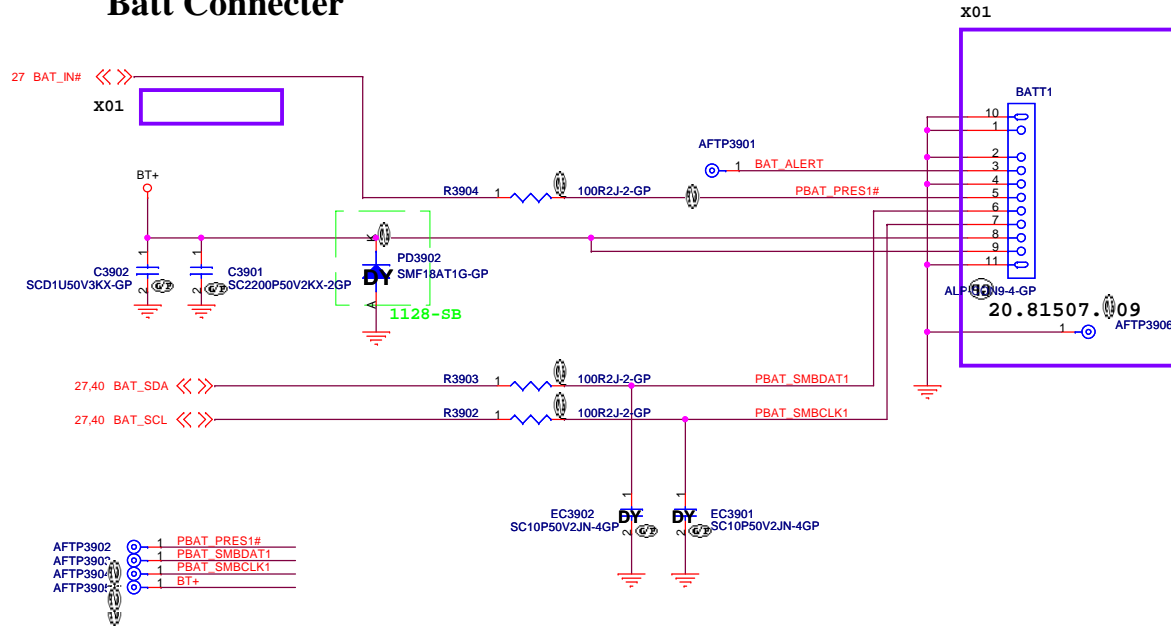

- AFTP3902 1 PBAT_PRESENT#
- AFTP3903 1 PBAT_SMBDAT1
- AFTP3904 1 PBAT_SMBCLK1
- AFTP3905 1 BT+

Close to Batt Connector

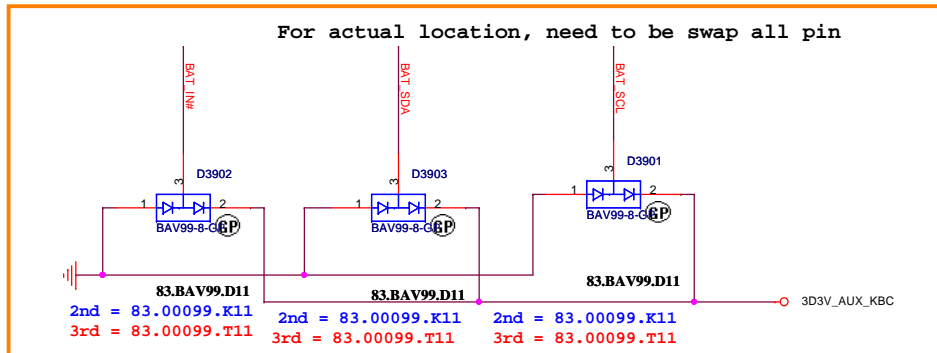

<Core Design>

		Wistron Corporation 21F, 88, Sec.1, Hsin Tai Wu Rd., Hsichih, Taipei Hsien 221, Taiwan, R.O.C.	
		Title: BATT CONN	
Size: A3	Document Number: Enrico 14 AMD	Rev: A00	
Date: Friday, April 22, 2011	Sheet: 39	of: 109	

SSID = Charger

EE need pull high and net name

0802 Rename_H_PROCHOT#

6.27 H_PROCHOT#

2010/11/10 X01

2010/11/10 X01

2010/11/10 X01

2010/11/10 X01

2010/11/10 X01

2010/11/10 X01

2010/11/10 X01

2010/11/10 X01

2010/11/10 X01

2010/11/10 X01

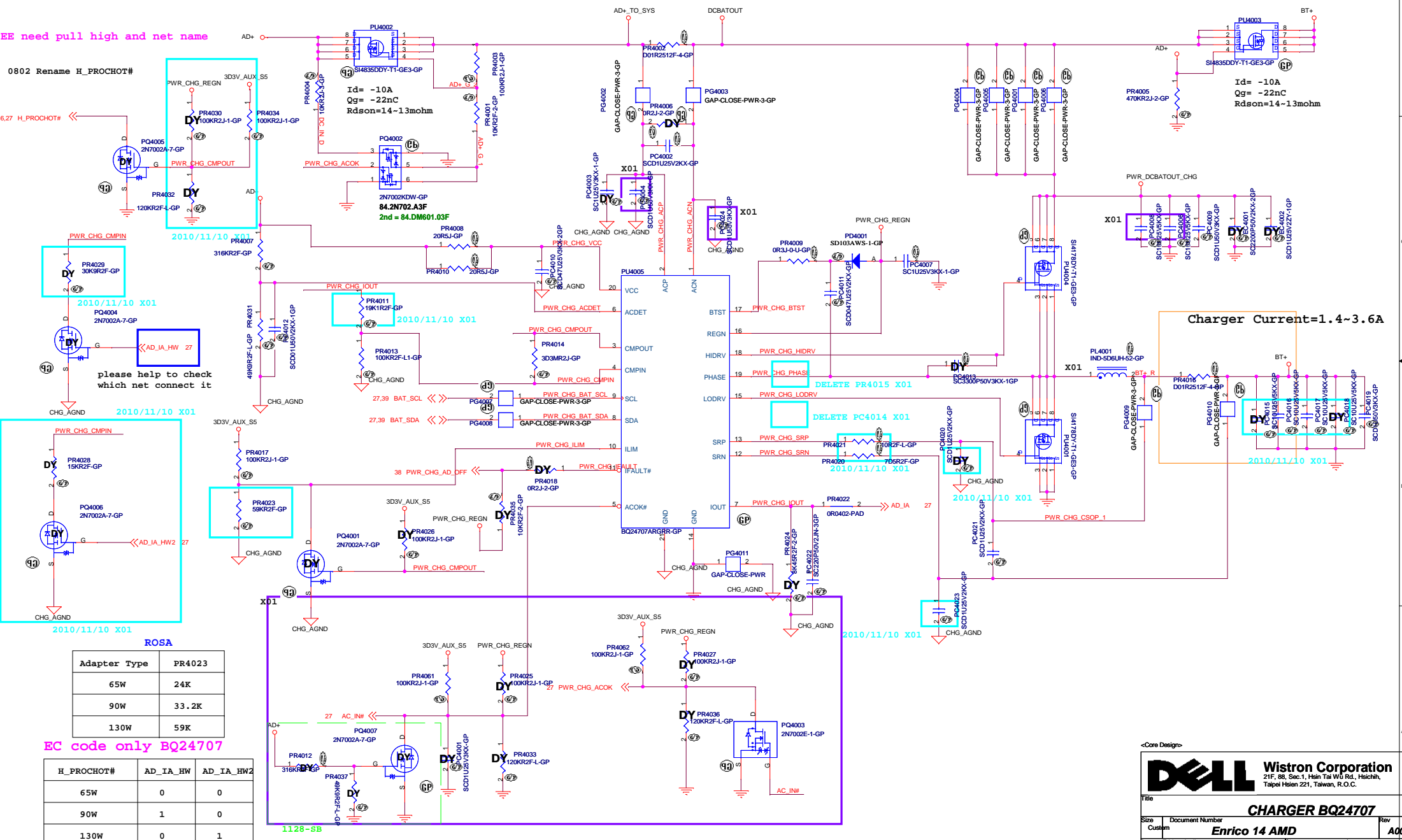

ROSA

Adapter Type	PR4023
65W	24K
90W	33.2K
130W	59K

EC code only BQ24707

H_PROCHOT#	AD_IA_HW	AD_IA_HW2
65W	0	0
90W	1	0
130W	0	1

©Core Design

21F, 88, Sec.1, Hsin Tai Wu Rd., Heichih, Taipei Hsien 221, Taiwan, R.O.C.

Title: **CHARGER BQ24707**

Size	Document Number	Rev
Custom	Enrico 14 AMD	A00

Date: Friday, April 22, 2011 Sheet 40 of 109

SSID = PWR.Plane.Regulator_3p3v5v

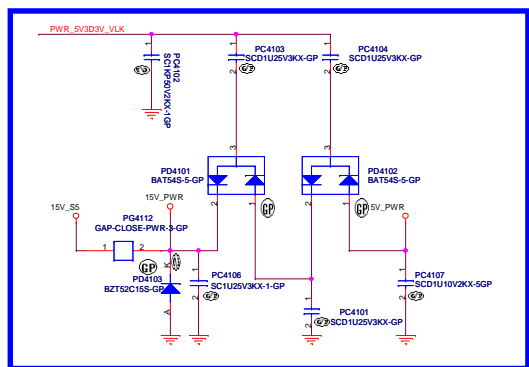
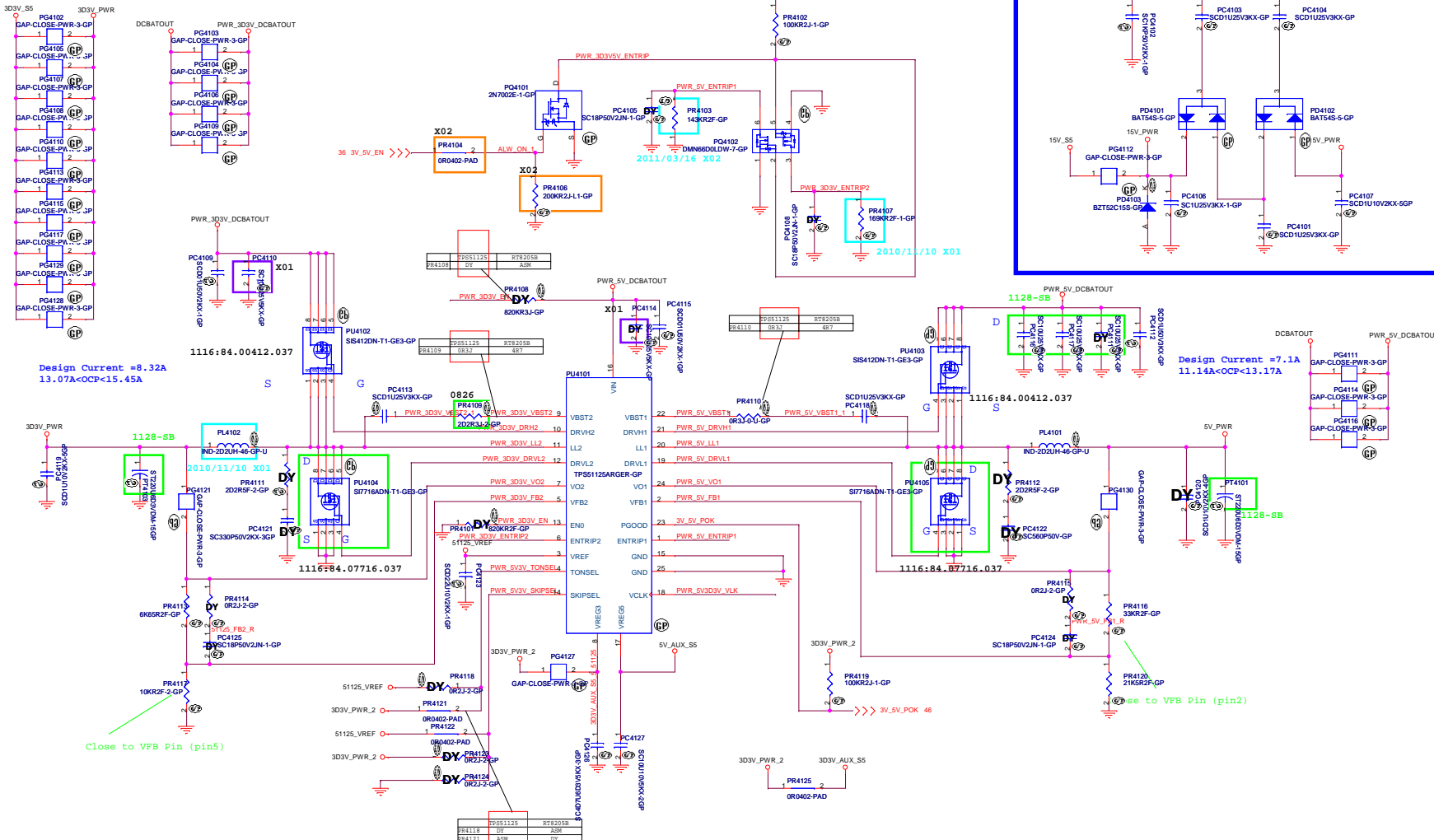

Design Current = 8.32A
13.07A <math>OCP < 15.45A</math>

Design Current = 7.1A
11.14A <math>OCP < 13.17A</math>

I/P cap: 10U 25V K1206 X5R/ 78.10622.52L
Inductor: 2.2uH PCMC063T-2R2MN Cynotec 18mohm/20mohm Isat =14Arms 68.2R210.20B
O/P cap: 220U 6.3V PPS1V03227M(25) 25mOhm 2.236Arms NEC_TOKIN/77_C2271.00L
O/P cap: 100U 6.3V TEPSEL20J107M(45)18R 45mohm 1.374Arms NEC_TOKIN/77_C1071.081
H/S: TPC8061-H / 21mohm/30mOhm@4.5Vgs/ 84.08061.037
L/S: TPCA8065-H / 12mohm/15mOhm@4.5Vgs/ 84.08065.037

I/P cap: 10U 25V K0805 X5R/ 78.10622.51L
Inductor: 2.2uH PCMC063T-2R2MN Cynotec 18mohm/20mohm Isat =14Arms 68.2R210.20B
O/P cap: 220U 6.3V PPS1V03227M(25) 25mOhm 2.236Arms NEC_TOKIN/77_C2271.00L
H/S: TPC8061-H / 21mohm/30mOhm@4.5Vgs/ 84.08061.037
L/S: TPCA8065-H / 12mohm/15mOhm@4.5Vgs/ 84.08065.037

PS51125:

TONSEL	CH1	CH2
GND	200kHz	265kHz
VREF	245kHz	305kHz
VREG3	300kHz	375kHz
VREG5	365kHz	460kHz

PS205B:

TONSEL	CH1	CH2
GND	200kHz	250kHz
VREF	300kHz	375kHz
VREG3	365kHz	460kHz
VREG5	365kHz	460kHz

SKIPSEL	VREG3 or VREG5	VREF(2V)	GND
Operating Mode	OOA Auto Skip	Auto Skip	PWM only

ENO	Open	820k to GND	GND
Operating Mode	enable both LDOs, VCLK on and ready to turn on switcher channels	enable both LDOs, VCLK off and ready to turn on switcher channels	disable all circuit

<Core Design>

Wistron Corporation
21F, 8F, 8C, Sec 1, Hsin Tai Wu Rd., Hsichia, Taipei Hsien 221, Taiwan, R.O.C.

Title: **TPS51125_5V3D3V**
Size A2 Document Number: **Enrico 14 AMD** Rev: **A00**
Date: Friday, April 22, 2011 Sheet 41 of 108

SSID = PWR.Plane.CORE.REG

Please help to check the net whether can change to 3D3V_S5

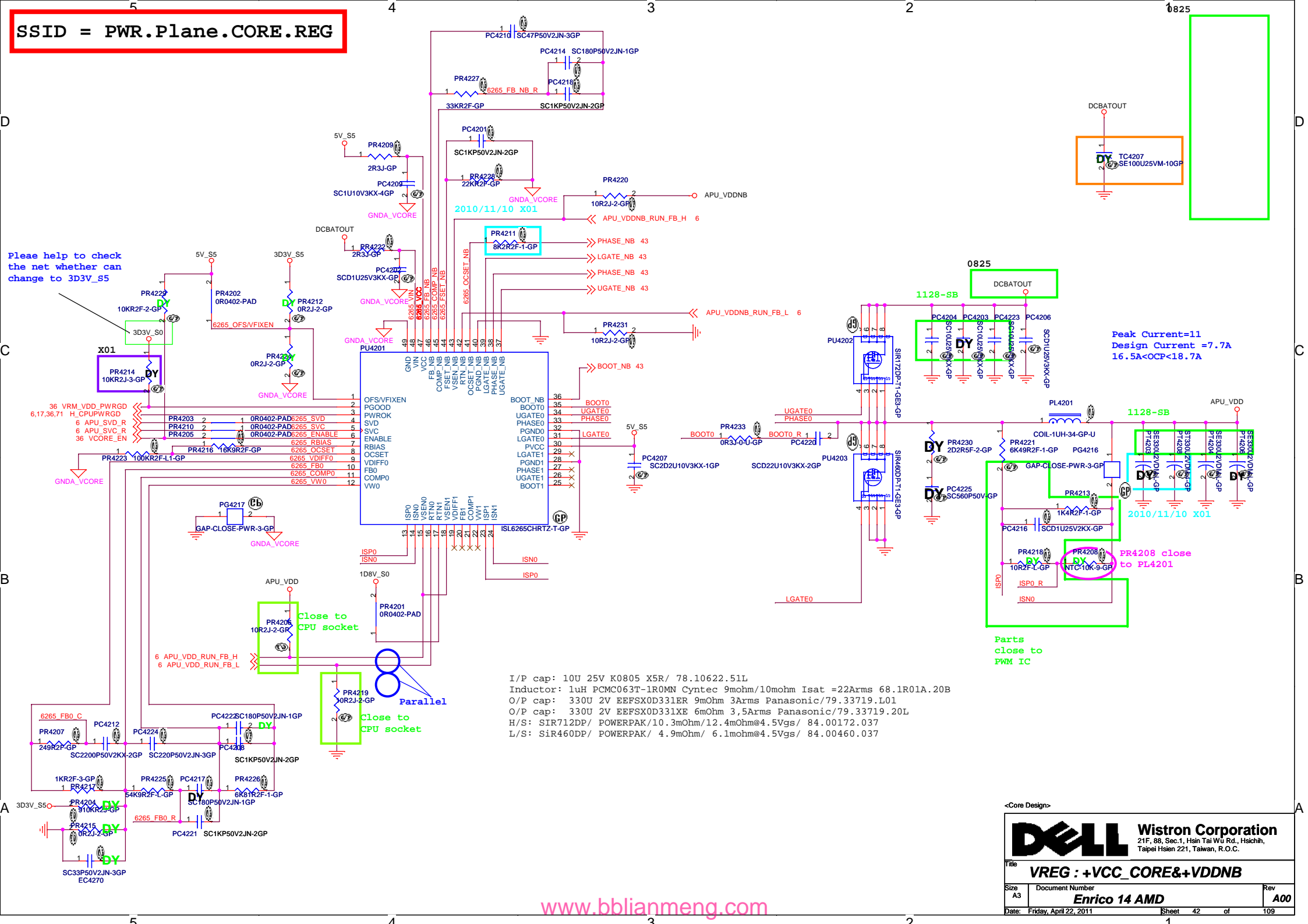

Peak Current=11
Design Current =7.7A
16.5A<OCP<18.7A

I/P cap: 10U 25V K0805 X5R/ 78.10622.51L
 Inductor: 1uH PCMC063T-1R0MN Cyntec 9mohm/10mohm Isat =22Arms 68.1R01A.20B
 O/P cap: 330U 2V EEFSX0D331ER 9mOhm 3Arms Panasonic/79.33719.L01
 O/P cap: 330U 2V EEFSX0D331XE 6mOhm 3,5Arms Panasonic/79.33719.20L
 H/S: SIR712DP/ POWERPAK/10.3mOhm/12.4mOhm@4.5Vgs/ 84.00172.037
 L/S: SIR460DP/ POWERPAK/ 4.9mOhm/ 6.1mohm@4.5Vgs/ 84.00460.037

<Core Design>

Wistron Corporation
 21F, 8B, Sec.1, Hsin Tai Wu Rd., Hsichih,
 Taipei Hsien 221, Taiwan, R.O.C.

Title: **VREG : +VCC_CORE&+VDDNB**

Size A3	Document Number	Rev
	Enrico 14 AMD	A00

Date: Friday, April 22, 2011 Sheet 42 of 109

SSID = PWR.Plane.VDDNB.REG

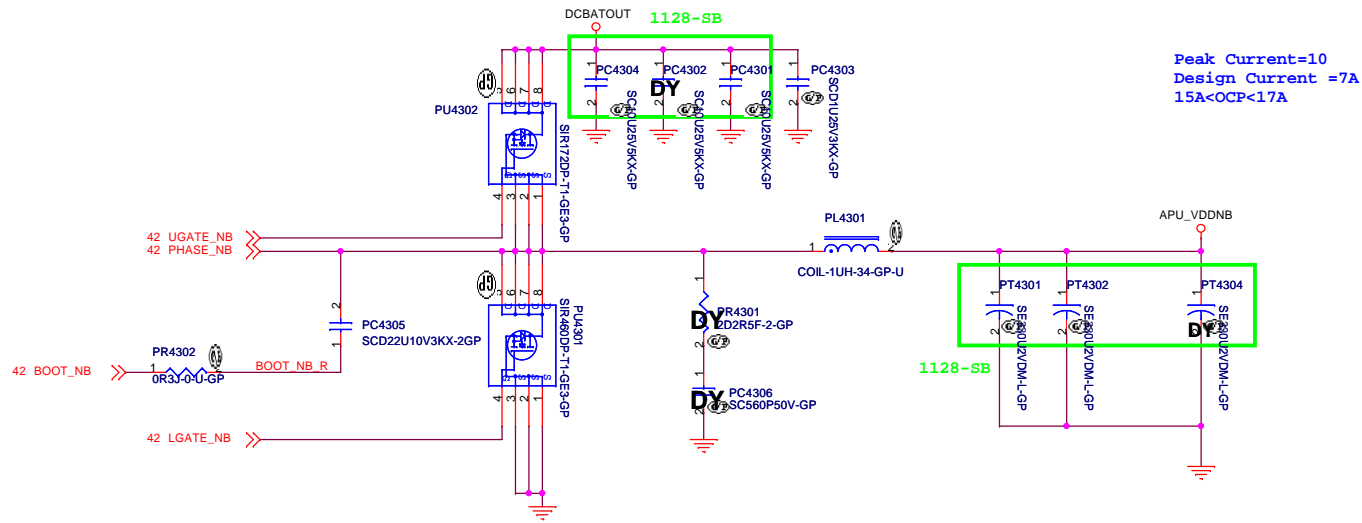

Peak Current=10
Design Current =7A
15A<OCP<17A

I/P cap: 10U 25V K0805 X5R/ 78.10622.51L
Inductor: 1uH PCMC063T-1R0MN Cyntec 9mohm/10mohm Isat =22Arms 68.1R01A.20B
O/P cap: 330U 2V EEFSX0D331ER 9mOhm 3Arms Panasonic/79.33719.L01
H/S: SIR712DP/ POWERPAK/10.3mOhm/12.4mOhm@4.5Vgs/ 84.00172.037
L/S: SiR460DP/ POWERPAK/ 4.9mOhm/ 6.1mohm@4.5Vgs/ 84.00460.037

<Core Design>

DELL		Wistron Corporation	
		21F, 88, Sec.1, Hsin Tai Wu Rd., Hsichih, Taipei Hsien 221, Taiwan, R.O.C.	
Title			
TPS51218 VDDNB			
Size	Document Number		Rev
A3	Enrico 14 AMD		A00
Date:	Friday, April 22, 2011	Sheet	43 of 109

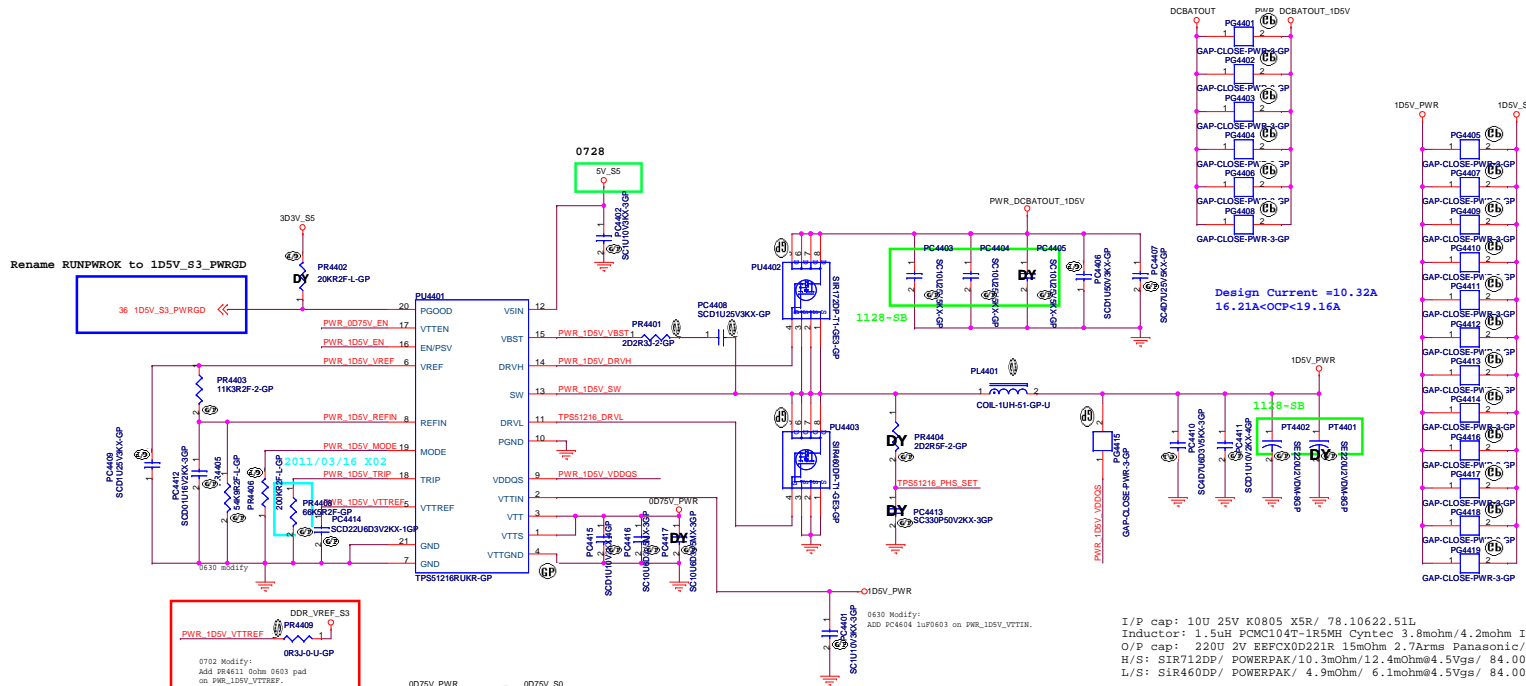

Design Current =10.32A
16.21A<OCP<19.16A

I/P cap: 10U 25V K0805 X5R/ 78.10622.51L
Inductor: 1.5uH PCMC104T-1R5MH Cyntec 3.8mohm/4.2mohm Isat =33Arms 68.1R510.20I
O/P cap: 220U 2V BEFCXD221R 15mOhm 2.7Arms Panasonic/79.22719.20L
H/S: SIR712DP/ POWERPAK/10.3mohm/12.4mOhms4.5Vgs/ 84.00172.037
L/S: SIR460DP/ POWERPAK/ 4.9mohm/ 6.1mohm4.5Vgs/ 84.00460.037

0702 Modify:
Add PR4411 0ohm 0603 pad
on PWR_1D5V_VTTREF.

0630 Modify:
Add PC4464 1uF0603 on PWR_1D5V_VTTIN.

State	S3	S5	VDDR	VTTREF	VTT
S0	Hi	Hi	On	On	On
S3	Lo	Hi	On	On	Off (Hi-Z)
S4/S5	Lo	Lo	Off	Off	Off

MODE	PR4406	Frequency	Discharge Mode
200k ohm	400kHz	Tracking Discharge	
100k ohm	300kHz		
68k ohm	300kHz	Non-tracking Discharge	
47k ohm	400kHz		

Intel Sequence, Remove

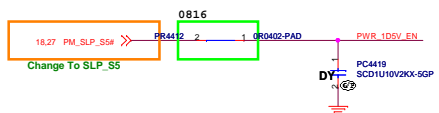
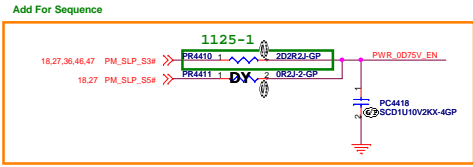

<Core Design>

DELL Wistron Corporation
21F, 88, Sec.1, Hsin Tai Wu Rd., Hsinchu, Taipei Hsin 221, Taiwan, R.O.C.

File: **RT8207 1D5V S3**

Size	Document Number	Rev
Custom	Enrico 14 AMD	A00

Date: Friday, April 22, 2011 Sheet 44 of 109

(Blanking)

<Core Design>

		Wistron Corporation 21F, 88, Sec.1, Hsin Tai Wu Rd., Hsichih, Taipei Hsien 221, Taiwan, R.O.C.	
Title			
VDDR & VDDP			
Size	Document Number	Rev	
A3	Enrico 14 AMD	A00	
Date: Friday, April 22, 2011	Sheet 45	of 109	

SSID = PWR.Plane.1V1REG

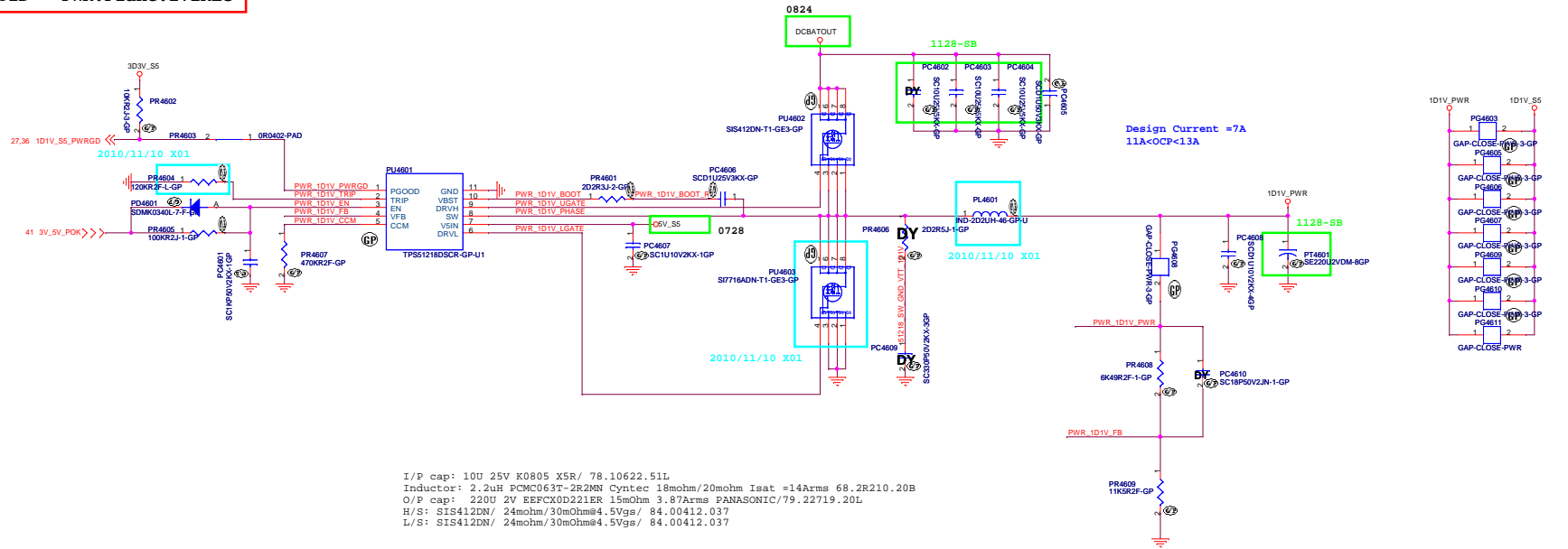

I/P cap: 10U 25V K0805 X5R/ 78.10622.51L
 Inductor: 2.2uH PCMC063T-2R2MN Cyntec 18mohm/20mohm Isat =14Arms 68.2R210.20B
 O/P cap: 220U 2V EEFX0D221ER 15mOhm 3.87Arms PANASONIC/79.22719.20L
 H/S: SIS412DN/ 24mohm/30mOhm@4.5Vgs/ 84.00412.037
 L/S: SIS412DN/ 24mohm/30mOhm@4.5Vgs/ 84.00412.037

$$V_{out} = 0.704V * (R1 + R2) / R2$$

SSID = PWR.Plane.1VREG

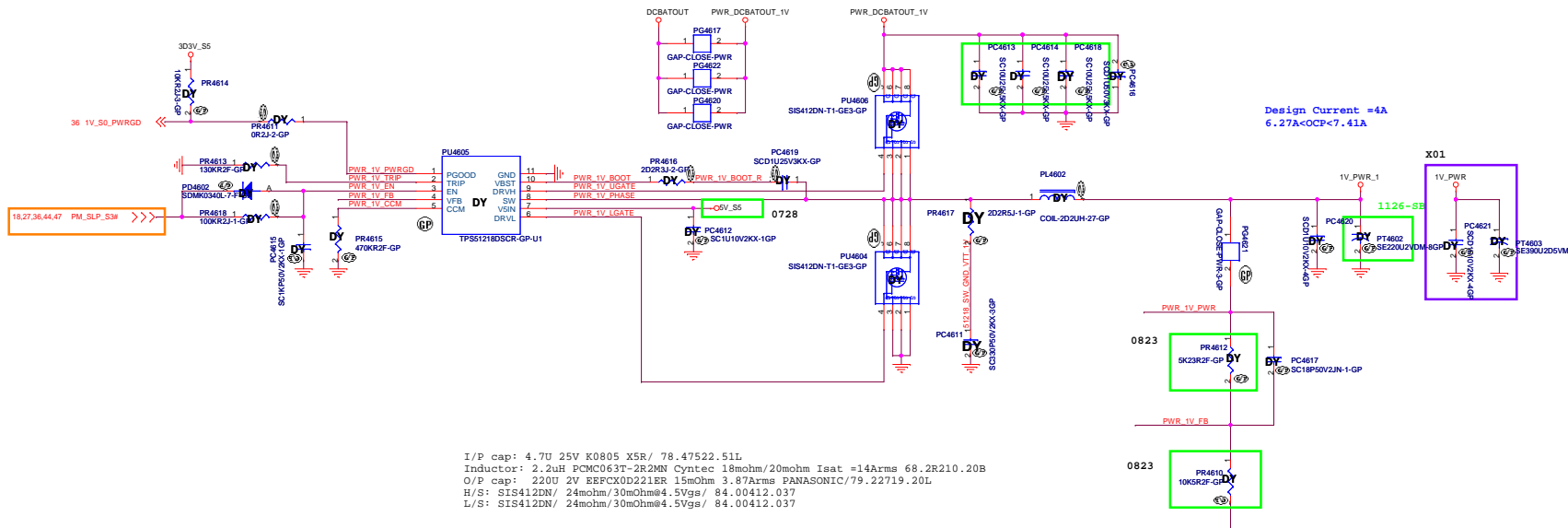

I/P cap: 4.7U 25V K0805 X5R/ 78.47522.51L
 Inductor: 2.2uH PCMC063T-2R2MN Cyntec 18mohm/20mohm Isat =14Arms 68.2R210.20B
 O/P cap: 220U 2V EEFX0D221ER 15mOhm 3.87Arms PANASONIC/79.22719.20L
 H/S: SIS412DN/ 24mohm/30mOhm@4.5Vgs/ 84.00412.037
 L/S: SIS412DN/ 24mohm/30mOhm@4.5Vgs/ 84.00412.037

$$V_{out} = 0.704V * (R1 + R2) / R2$$

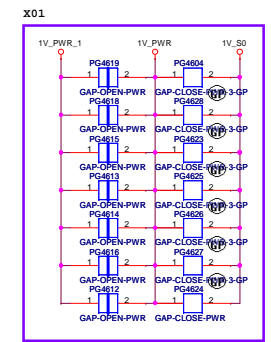

APW7153B for 1D8V_S0

Design Current = 3A

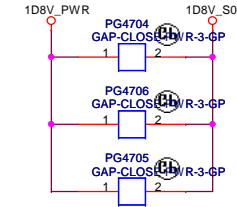
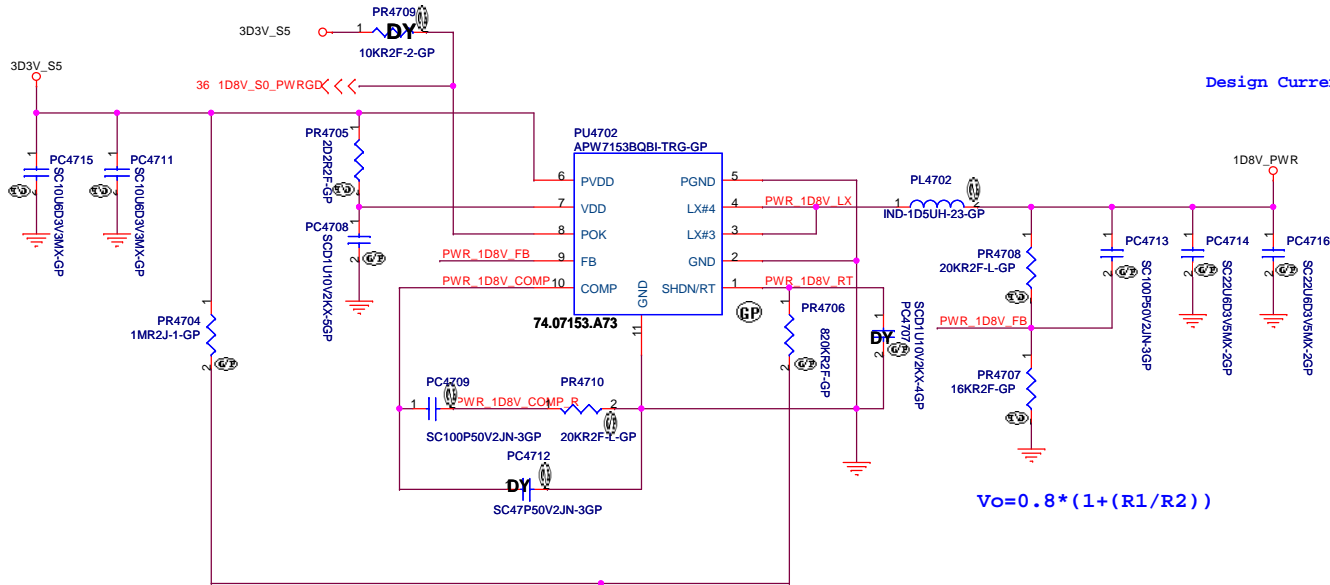

$$V_o = 0.8 * (1 + (R1/R2))$$

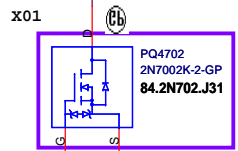

I/P cap: 4.7U 25V K0805 X5R/ 78.47522.51L
 O/P cap: 22U 25V M0805 X5R/ 78.22610.51L
 Inductor: 3.3uH PCMC063T-3R3MN Cyntec 28mohm/30mohm Isat =13.5Arms 68.3R310.20A

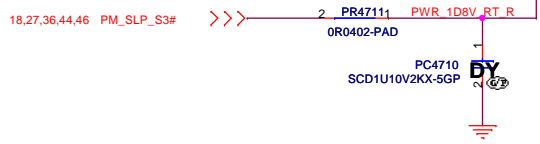

<Core Design>

Wistron Corporation
 21F, 88, Sec.1, Hsin Tai Wu Rd., Hsichih,
 Taipei Hsien 221, Taiwan, R.O.C.

Title		RT8015B 1D8V S0	
Size	Document Number	Rev	
A3	Enrico 14 AMD	A00	
Date: Friday, April 22, 2011	Sheet 47	of	109

(Blanking)

<Core Design>

		Wistron Corporation 21F, 88, Sec.1, Hsin Tai Wu Rd., Hsichih, Taipei Hsien 221, Taiwan, R.O.C.
Title		Reserved
Size	Document Number	Rev
A3	Enrico 14 AMD	A00
Date: Friday, April 22, 2011	Sheet 48 of 109	

SSID = VIDEO

LVDS CONNECTOR

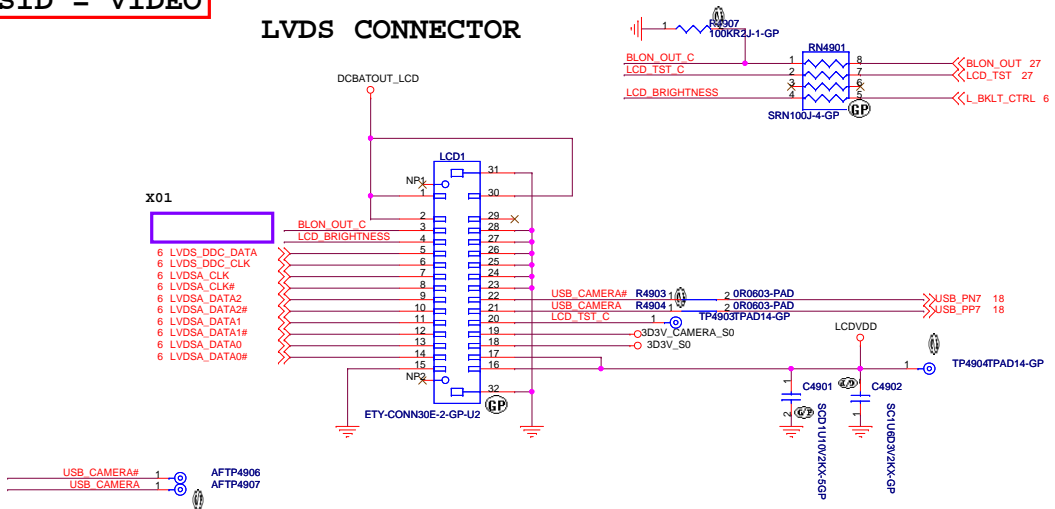

INVERTER POWER

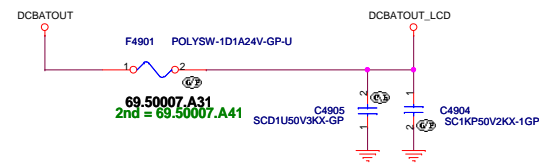

Camera Power

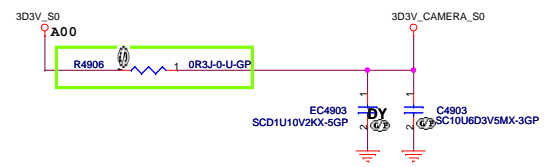

Close to LVDS connector

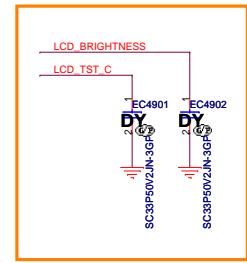
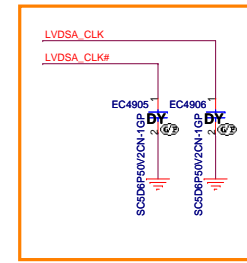

For EMI request

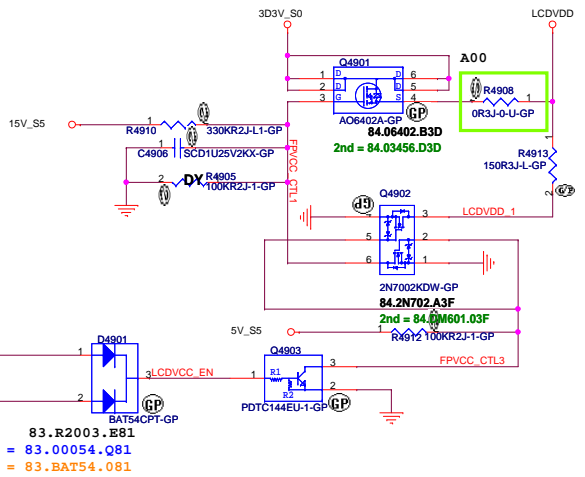

<Core Design>

DELL Wistron Corporation
21F, 88, Sec.1, Hsin Tai Wu Rd., Hsichih,
Taipei Hsien 221, Taiwan, R.O.C.

Title
LCD/Inverter Connector

Size	Document Number	Rev
Custom	Enrico 14 AMD	A00
Date:	Friday, April 22, 2011	Sheet 49 of 109

SSID = VIDEO

Layout Note:

- *Pi-filter & 150 Ohm pull-down resistors should be as close as to CRT CONN.
- * RGB signal will hit 75 Ohm first, then pi-filter, finally CRT CONN.

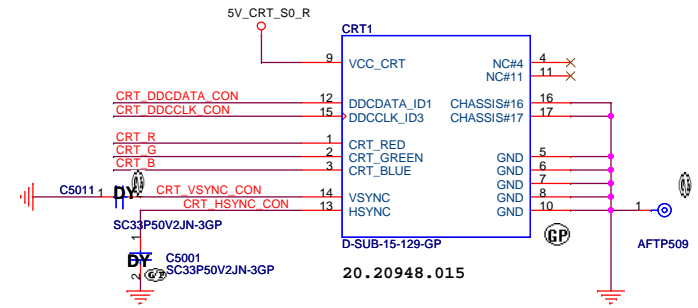
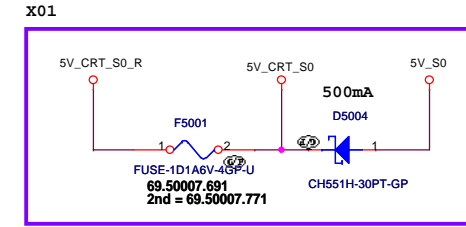
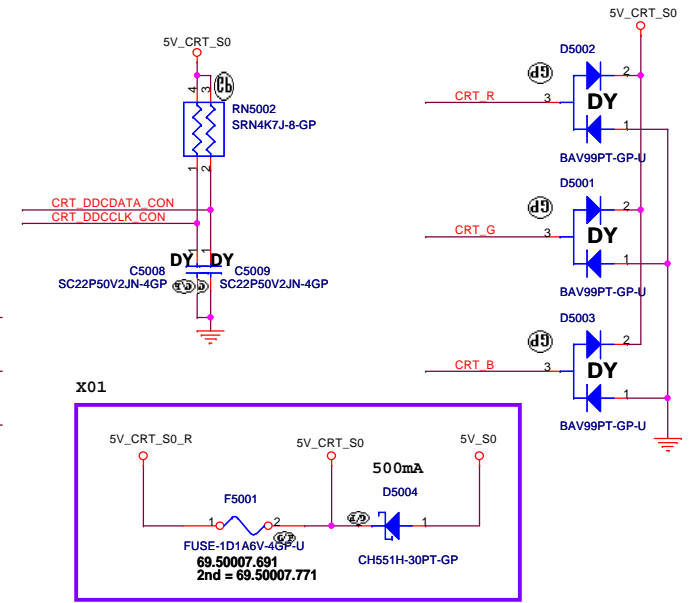
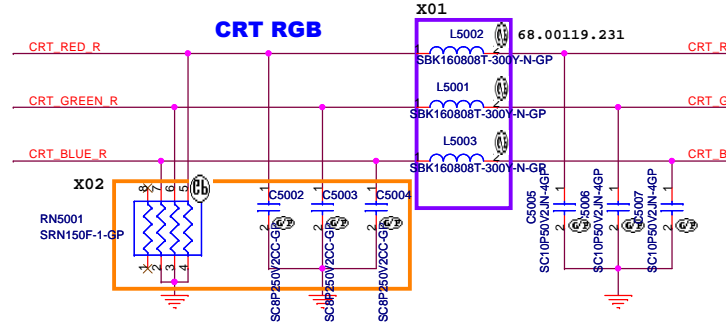
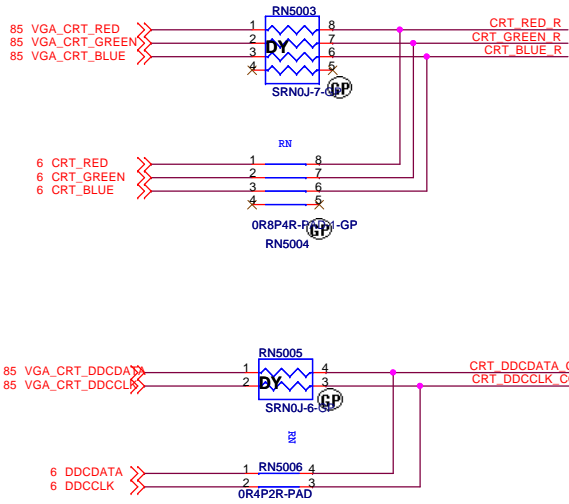

CRT Hsync & Vsync level shift

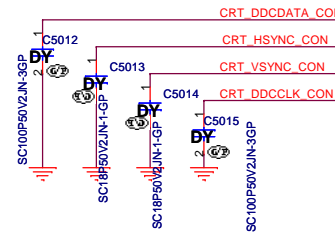
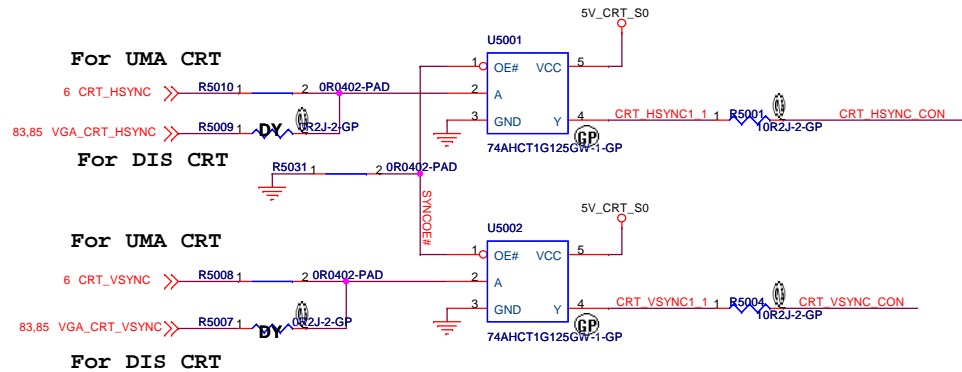

- AFTP501 1 5V CRT_S0
- AFTP502 1 CRT_DDCDATA_CON
- AFTP503 1 CRT_DDCLK_CON
- AFTP504 1 CRT_R
- AFTP505 1 CRT_G
- AFTP506 1 CRT_B
- AFTP507 1 CRT_HSYNC_CON
- AFTP508 1 CRT_VSYNC_CON

Core Design

DELL Wistron Corporation
 21F, 88, Sec.1, Hsin Tai Wu Rd., Hsichih,
 Taipei Hsien 221, Taiwan, R.O.C.

File _____

Size **A3** Document Number _____ Rev **A00**

Date: Friday, April 22, 2011 Sheet 50 of 109

SSID = VIDEO

HDMI Level Shifter & CONNECTOR

HDMI CONN

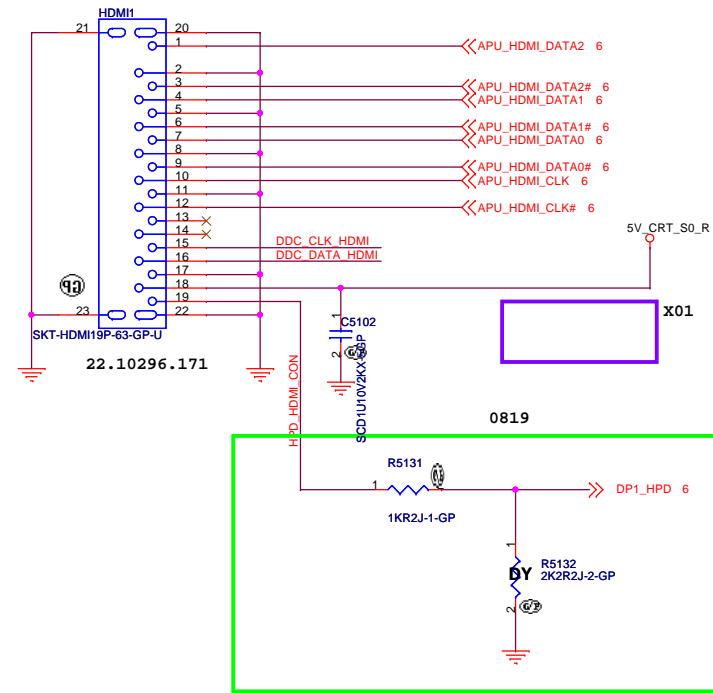
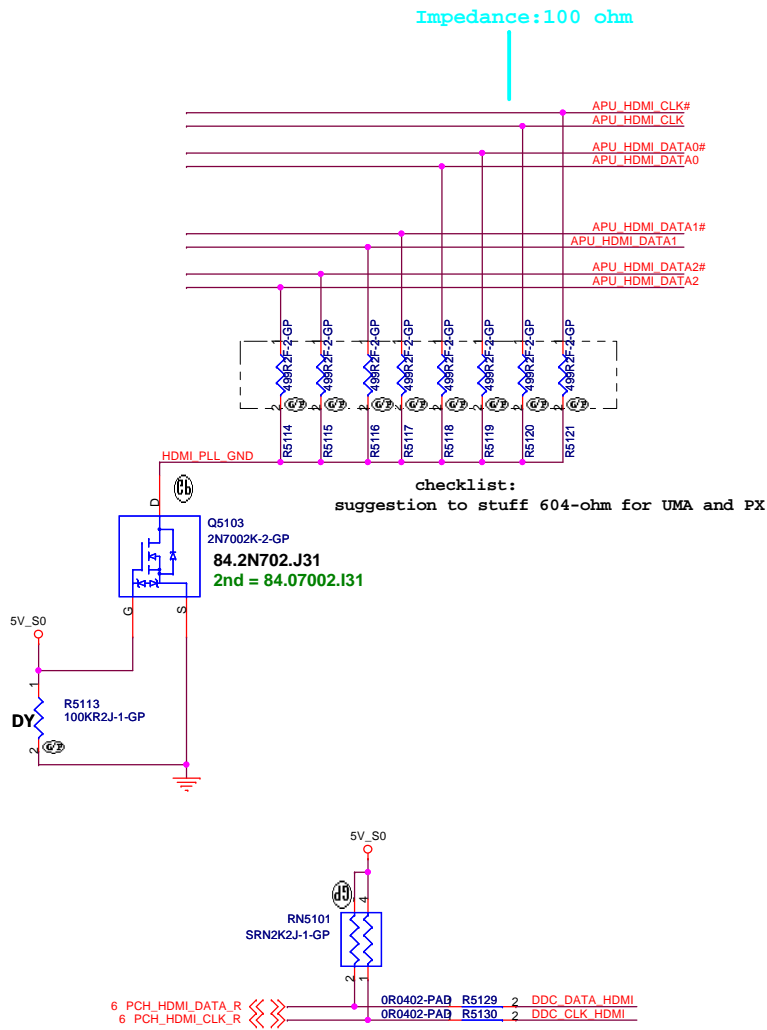

<Core Design>



Title HDMI Level Shifter/Connector		
Size A3	Document Number Enrico 14 AMD	Rev A00
Date: Friday, April 22, 2011	Sheet 51	of 109



<Core Design>

		Wistron Corporation	
		21F, 88, Sec.1, Hsin Tai Wu Rd., Hsichih, Taipei Hsien 221, Taiwan, R.O.C.	
Title			
eDP			
Size	Document Number	Rev	
A3			A00
Date: Friday, April 22, 2011		Sheet 52	of 109

(Blanking)

<Core Design>

		Wistron Corporation 21F, 88, Sec.1, Hsin Tai Wu Rd., Hsichih, Taipei Hsien 221, Taiwan, R.O.C.
Title		
Reserved		
Size	Document Number	Rev
A3	Enrico 14 AMD	A00
Date: Friday, April 22, 2011	Sheet 53	of 109

(Blanking)

<Core Design>

		Wistron Corporation 21F, 88, Sec.1, Hsin Tai Wu Rd., Hsichih, Taipei Hsien 221, Taiwan, R.O.C.	
Title			
Reserved			
Size	Document Number	Rev	
A3	Enrico 14 AMD	A00	
Date:	Friday, April 22, 2011	Sheet 54 of	109

SSID = User.Interface

ITP Connector

H_CPURST# use pull-up Resistor close
ITP connector 500 mil (max),
others place near CPU side.

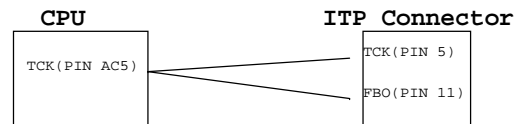

<Core Design>

DELL		Wistron Corporation	
		21F, 88, Sec. 1, Hsin Tai Wu Rd., Hsichih, Taipei Hsien 221, Taiwan, R.O.C.	
Title			
ITP			
Size	Document Number	Rev	
A3	Enrico 14 AMD	A00	
Date: Friday, April 22, 2011	Sheet 55	of	109

SSID = SATA

SATA HDD Connector

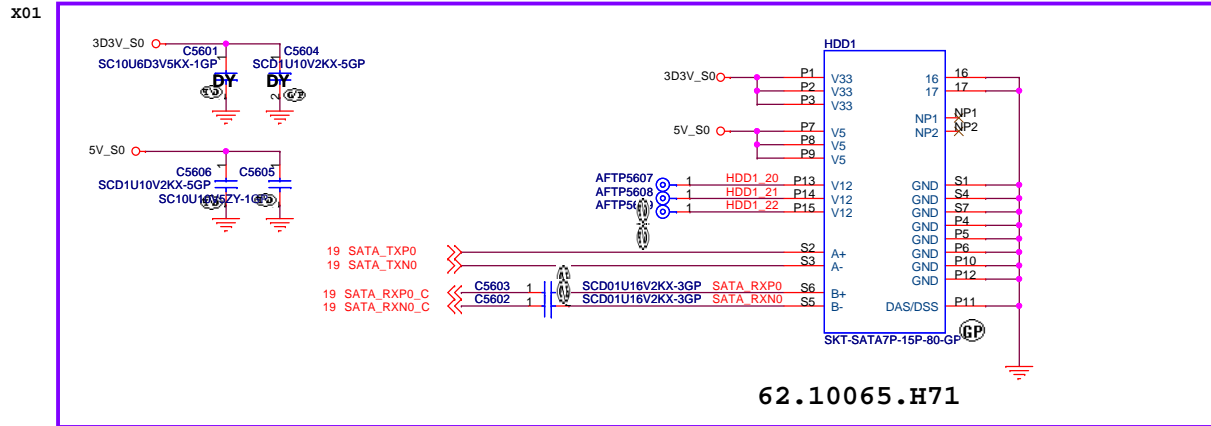

ODD Connector

SATA_RX- and SATA_RX+ Trace Length match within 20 mil

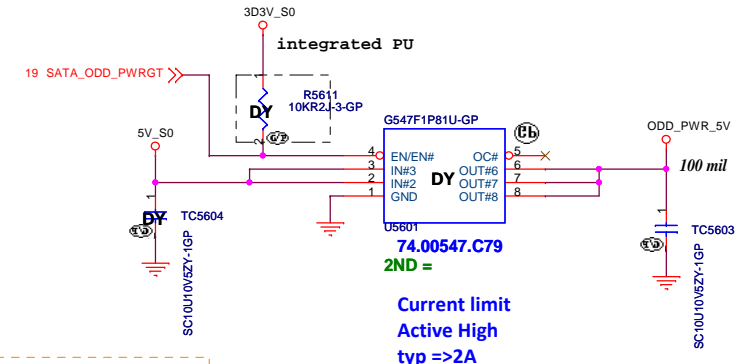
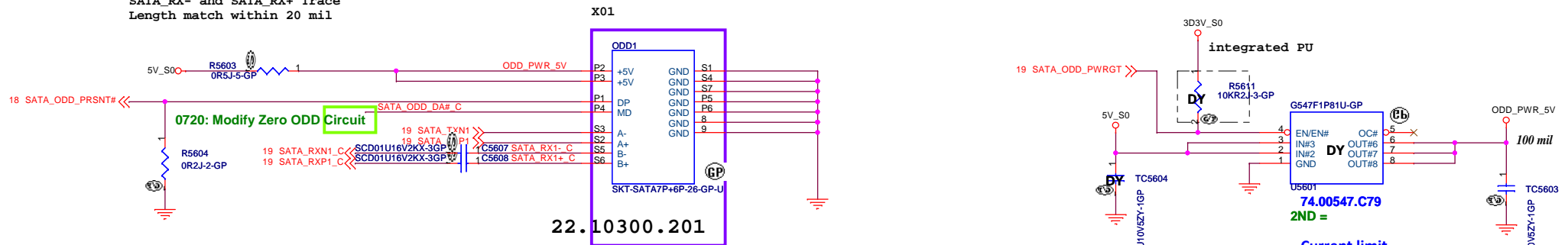

0720: Modify Zero ODD Circuit

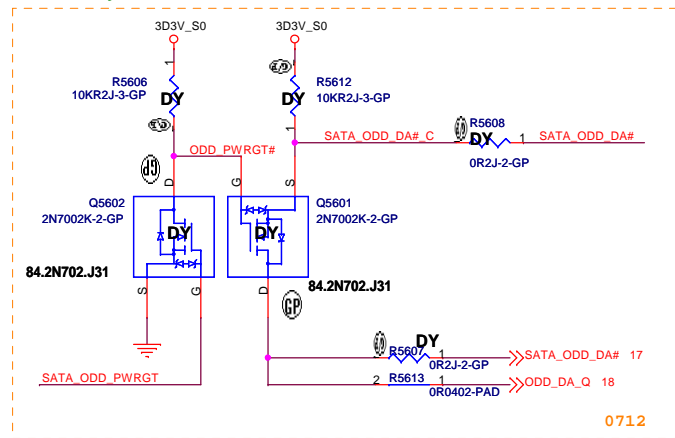

0721 Remove ODD_DA PU

When the drive is powered on, the FET to the MD/DA pin drive is OFF.
When the drive is powered off, the FET to the MD/DA pin is ON

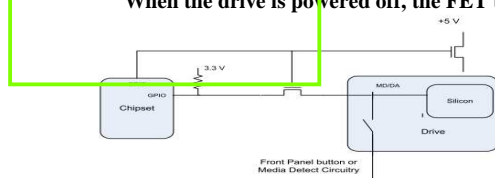

<Core Design>

DELL Wistron Corporation
21F, 88, Sec. 1, Hsin Tai Wu Rd., Hsichih, Taipei Hsien 221, Taiwan, R.O.C.

Title: **HDD/ODD**

Size A3	Document Number Enrico 14 AMD	Rev A00
Date: Friday, April 22, 2011	Sheet 56 of 109	

SSID = ESATA

(Blanking)

<Core Design>

		Wistron Corporation 21F, 88, Sec.1, Hsin Tai Wu Rd., Hsichih, Taipei Hsien 221, Taiwan, R.O.C.	
Title			
ESATA/USB Charger			
Size	Document Number	Rev	
A3		Enrico 14 AMD	A00
Date: Friday, April 22, 2011		Sheet 57 of 109	

SSID = AUDIO

Speaker Connector

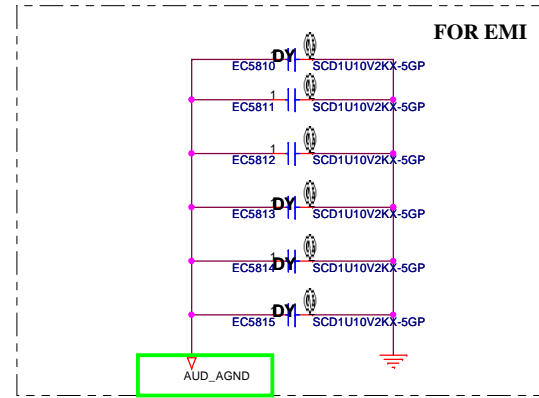
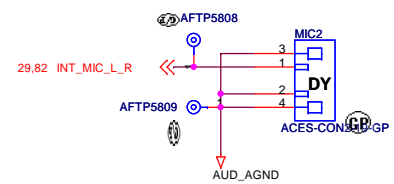
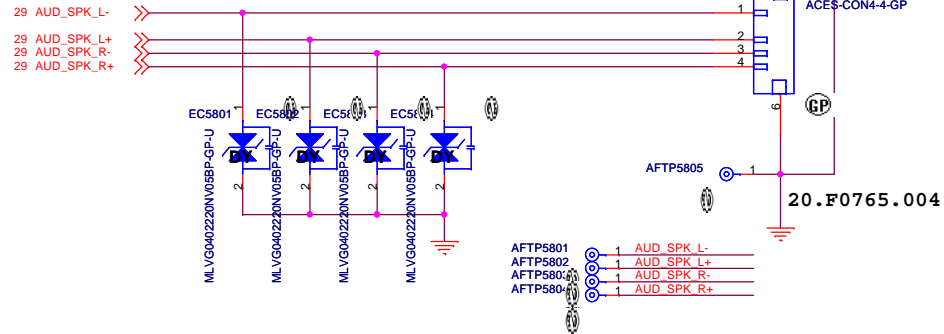

0804 Change to AGND

<Core Design>

DELL Wistron Corporation
21F, 88, Sec.1, Hsin Tai Wu Rd., Hsichih, Taipei Hsien 221, Taiwan, R.O.C.

Title: **Audio Jack**

Size: A3	Document Number: Enrico 14 AMD	Rev: A00
Date: Friday, April 22, 2011	Sheet 58 of 109	

LAN TransFormer

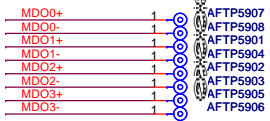
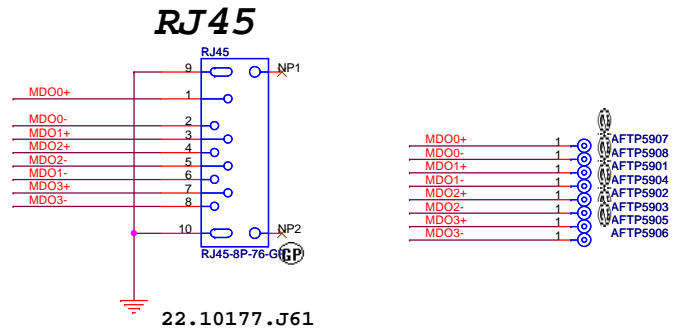
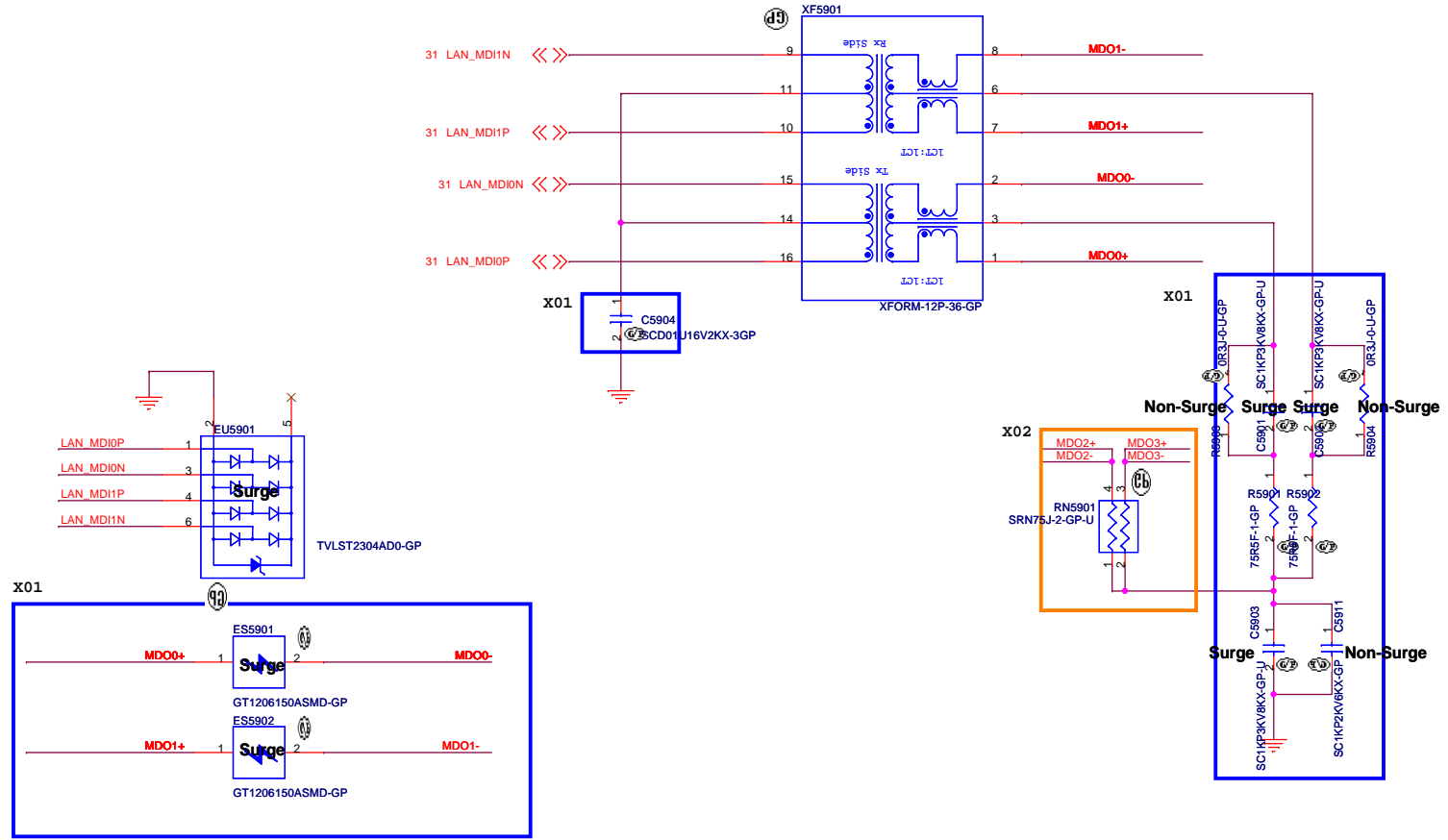

22.10177.J61

<Core Design>

DELL Wistron Corporation
21F, 88, Sec.1, Hsin Tai Wu Rd., Hsichih,
Taipei Hsien 221, Taiwan, R.O.C.

Title: **LAN**

Size: A3	Document Number: Enrico 14 AMD	Rev: A00
Date: Friday, April 22, 2011	Sheet: 59	of 109

SSID = Flash.ROM

SPI FLASH ROM (2M byte) for KBC

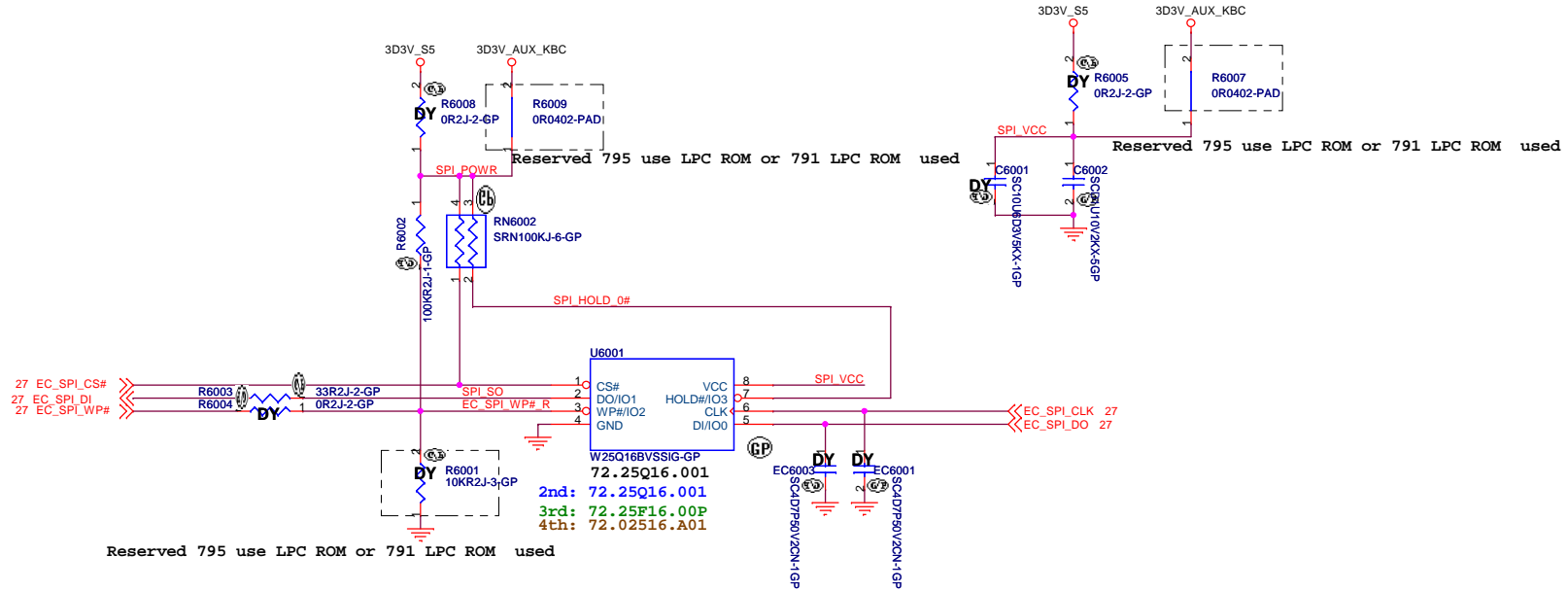

SSID = RBATT

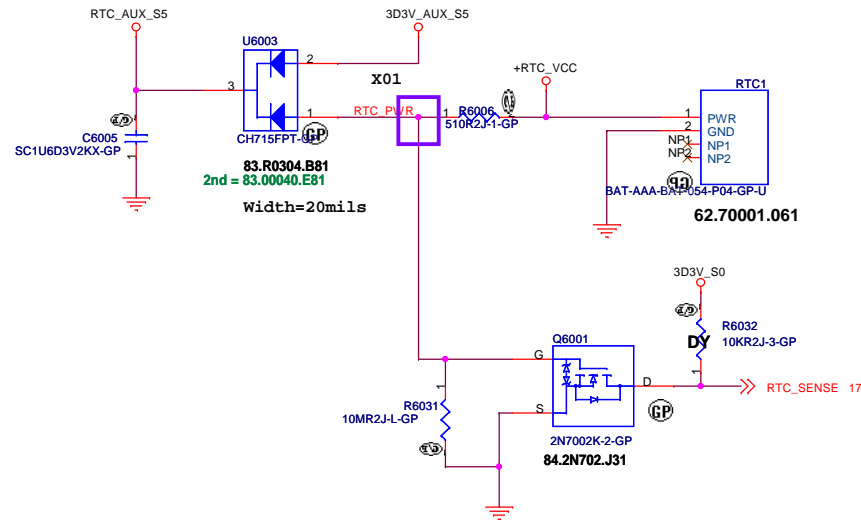

<Core Design>



Title Flash/RTC		
Size A3	Document Number Enrico 14 AMD	Rev A00
Date: Friday, April 22, 2011	Sheet 60	of 109

SSID = USB

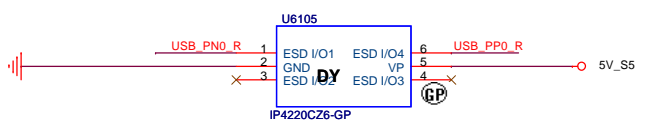
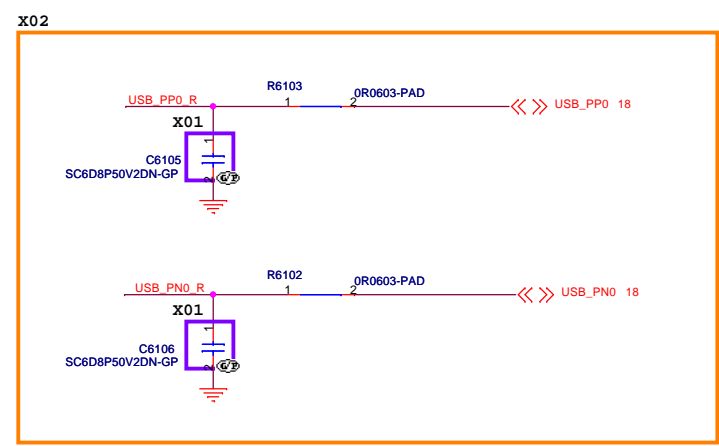
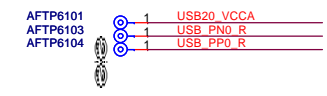
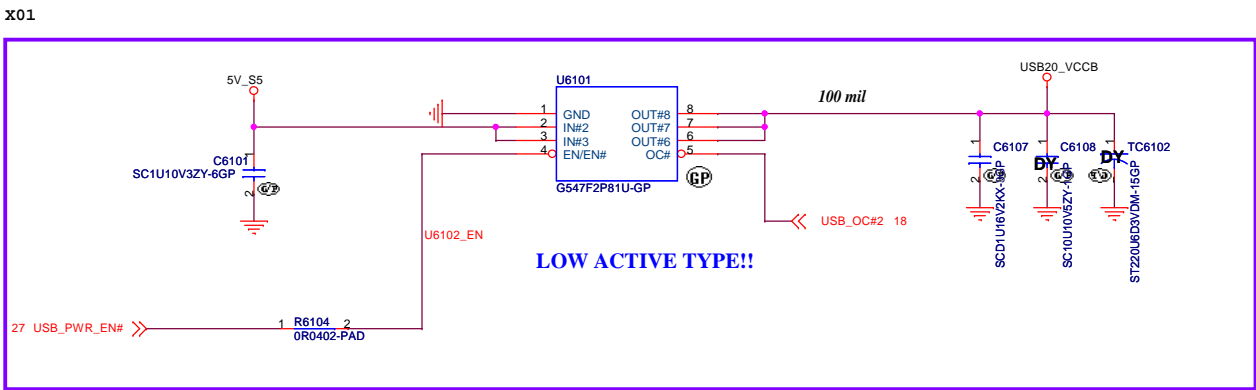
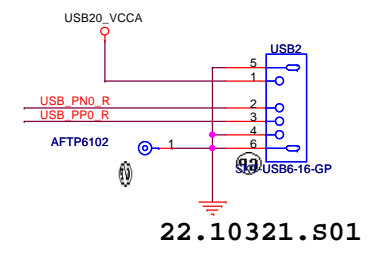
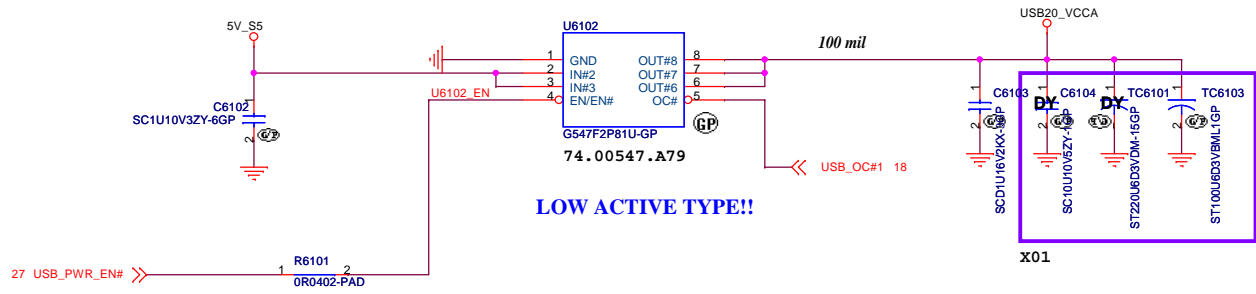

<Core Design>

DELL Wistron Corporation
21F, 88, Sec.1, Hsin Tai Wu Rd., Hsichih, Taipei Hsien 221, Taiwan, R.O.C.

Title: **USB Power SW**

Size	Document Number	Rev
	Enrico 14 AMD	A00

Date: Friday, April 22, 2011 Sheet 61 of 109

(Blanking)

<Core Design>

		Wistron Corporation 21F, 88, Sec.1, Hsin Tai Wu Rd., Hsichih, Taipei Hsien 221, Taiwan, R.O.C.	
Title			
USB 3.0			
Size	Document Number	Rev	
A3		A00	
Date:	Friday, April 22, 2011	Sheet	62 of 109

SSID = User.Interface

(Blanking)

<Core Design>

		Wistron Corporation 21F, 88, Sec. 1, Hsin Tai Wu Rd., Hsichih, Taipei Hsien 221, Taiwan, R.O.C.
Title		
Bluetooth		
Size	Document Number	Rev
A3	Enrico 14 AMD	A00
Date: Friday, April 22, 2011	Sheet 63 of 109	1

(Blanking)

<Core Design>

		Wistron Corporation 21F, 88, Sec. 1, Hsin Tai Wu Rd., Hsichih, Taipei Hsien 221, Taiwan, R.O.C.
Title		
F/P		
Size	Document Number	Rev
A3	Enrico 14 AMD	A00
Date: Friday, April 22, 2011	Sheet 64	of 109

SSID = Wireless

Mini Card Connector(802.11a/b/g/n)

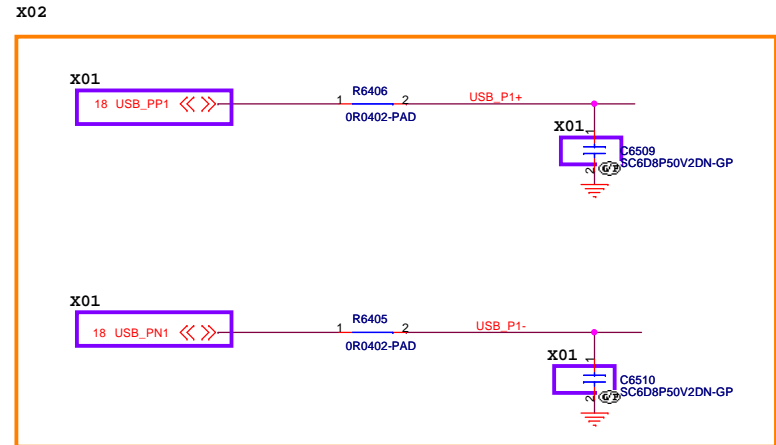
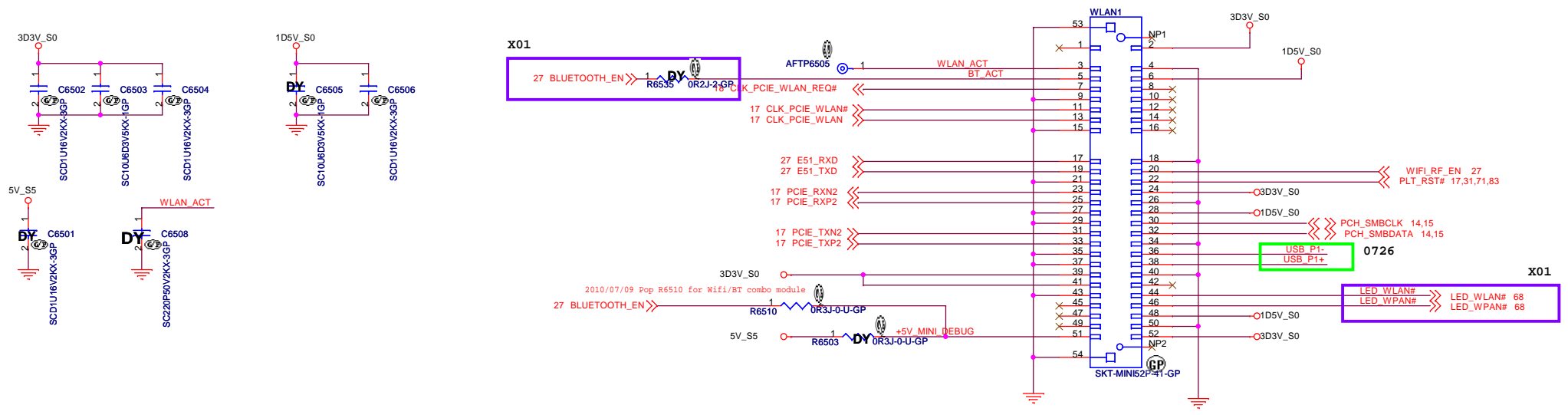

05/19 Add Common Mode Choke
 2010/07/16 Change CMC L6401 to smaller 69.10118.001 (the same same as other CMCs on MB) and rename L6401 to TR6501.
 Change R6406,R6405 to 0R 0402 size

<Core Design>

Wistron Corporation
 21F, 88, Sec.1, Hsin Tai Wu Rd., Hsichih,
 Taipei Hsien 221, Taiwan, R.O.C.

Title: **MINICARD(WLAN)/TP CONN**

Size: A3 Document Number: **Enrico 14 AMD** Rev: **A00**

Date: Friday, April 22, 2011 Sheet 65 of 109

(Blanking)

<Core Design>

		Wistron Corporation 21F, 88, Sec.1, Hsin Tai Wu Rd., Hsichih, Taipei Hsien 221, Taiwan, R.O.C.	
Title		WWAN	
Size A3	Document Number	Enrico 14 AMD	Rev A00
Date: Friday, April 22, 2011	Sheet	66	of 109

(Blanking)

<Core Design>

		Wistron Corporation 21F, 88, Sec. 1, Hsin Tai Wu Rd., Hsichih, Taipei Hsien 221, Taiwan, R.O.C.	
Title			
Reserved			
Size	Document Number	Rev	
A3	Enrico 14 AMD	A00	
Date:	Friday, April 22, 2011	Sheet	67 of 109

X01

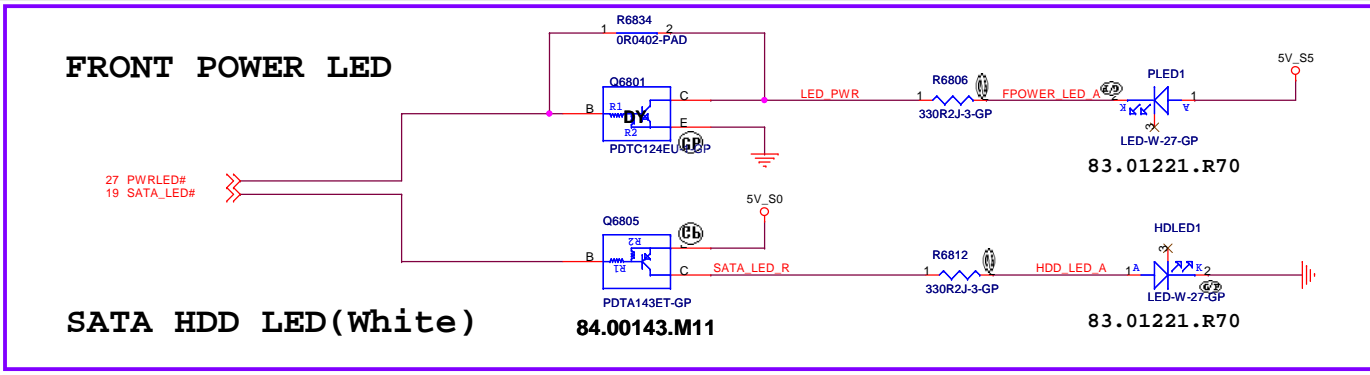

SSID = User.Interface

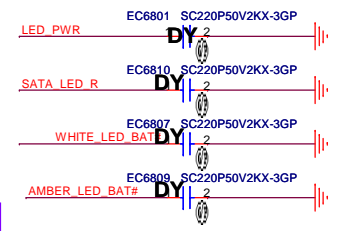

X01

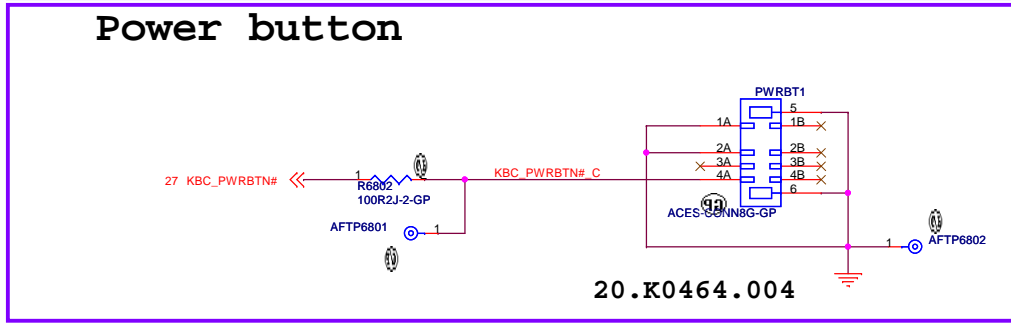
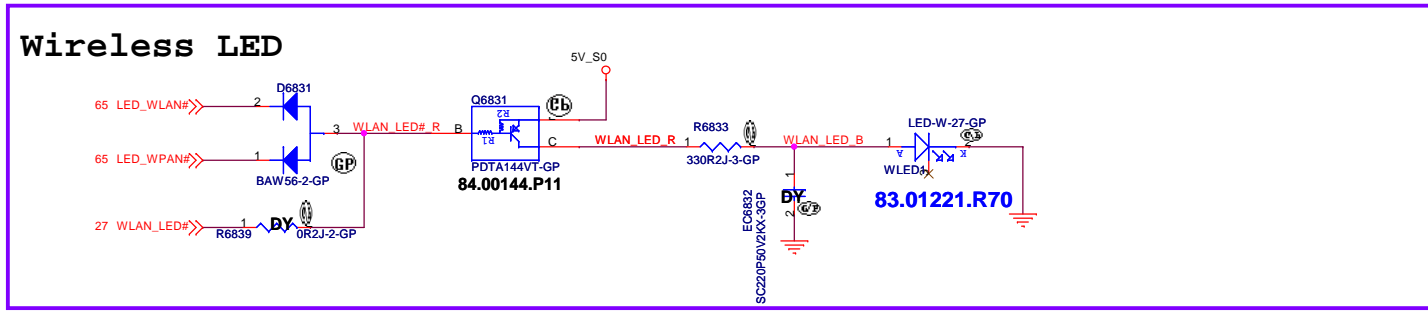
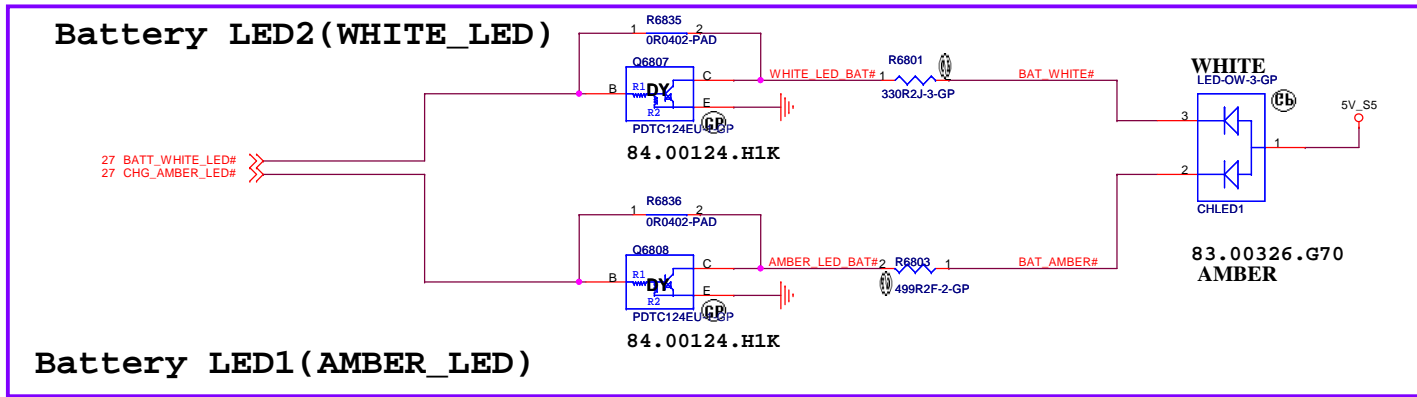

<Core Design>

Wistron Corporation
21F, 88, Sec.1, Hsin Tai Wu Rd., Hsichih, Taipei Hsien 221, Taiwan, R.O.C.

Title: **LED Bard/Power Button**

Size: A3	Document Number: Enrico 14 AMD	Rev: A00
Date: Friday, April 22, 2011	Sheet: 68	of: 109

SSID = KBC

X01

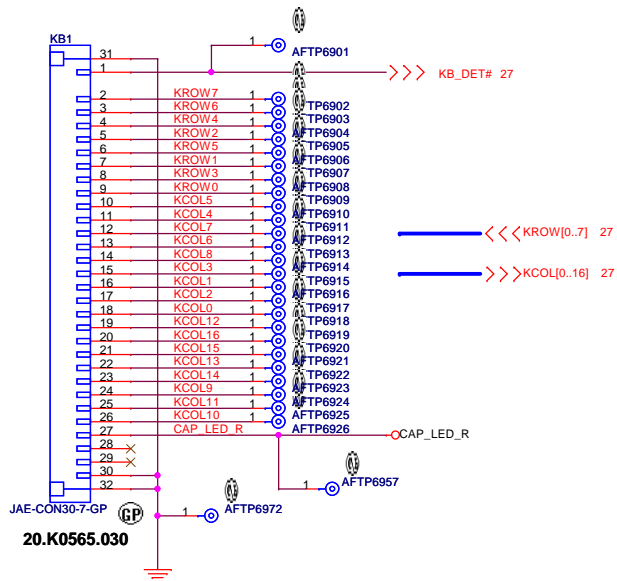

20101116 X02 Modify:
Change R6906 to 1K from 390ohm for
fine tune LED illumination.
20101118 X02:
Dell recommend: change all white LEDs resistor to 620 ohm.
20101202 X02:
Dell recommend: change all white LEDs resistor to 604 ohm.

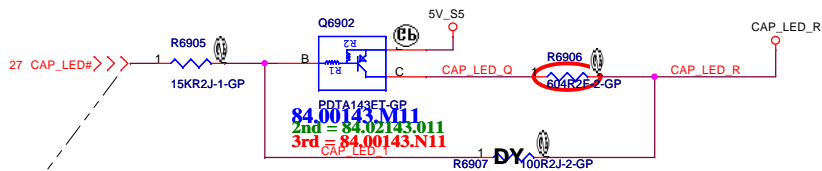

CAP_LED:(X01 Low active)
Connect to KB driving internal LED directly.(MAX 25mA)

TouchPad Connector

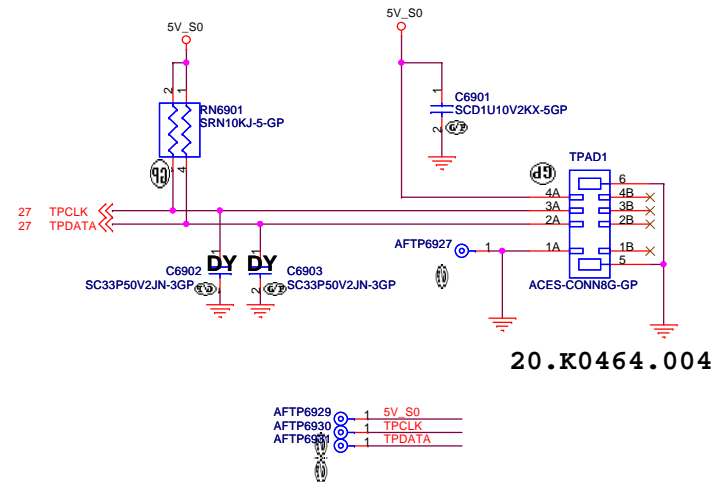

<Core Design>

DELL		Wistron Corporation	
		21F, 88, Sec.1, Hsin Tai Wu Rd., Hsichih, Taipei Hsien 221, Taiwan, R.O.C.	
Title			
Key Board/Touch Pad			
Size	Document Number	Rev	
A3	Enrico 14 AMD	A00	
Date:	Friday, April 22, 2011	Sheet	69 of 109

SSID = Hall.Sensor

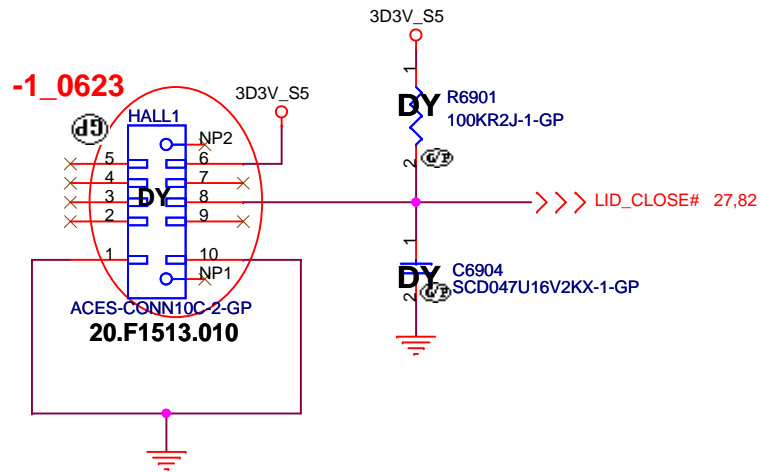

<Core Design>

		Wistron Corporation 21F, 88, Sec.1, Hsin Tai Wu Rd., Hsichih, Taipei Hsien 221, Taiwan, R.O.C.
Title Hall Effect Sensor		
Size A4	Document Number Enrico 14 AMD	Rev A00
Date: Friday, April 22, 2011	Sheet 70 of 109	

SSID = Debug

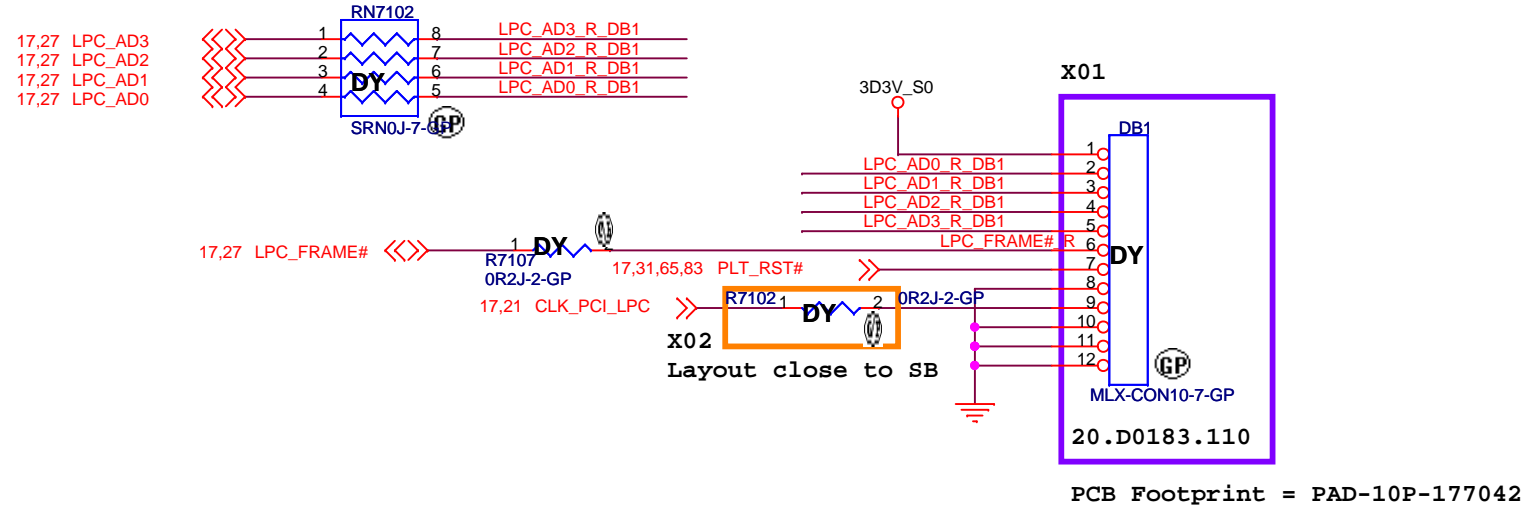

DY HDT+

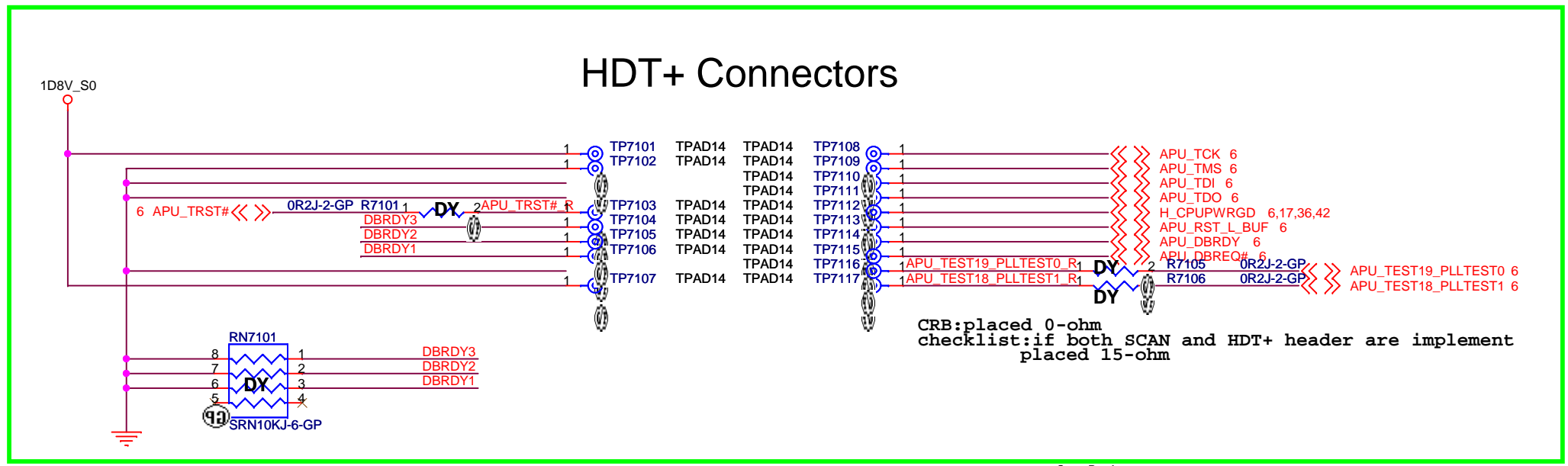

<Core Design>

		Wistron Corporation 21F, 88, Sec.1, Hsin Tai Wu Rd., Hsichih, Taipei Hsien 221, Taiwan, R.O.C.	
		Title <h3 style="text-align: center;">Dubug connector</h3>	
Size A4	Document Number <h3 style="text-align: center;">Enrico 14 AMD</h3>	Rev <h3 style="text-align: right;">A00</h3>	
Date: Friday, April 22, 2011	Sheet 71	of 1	109

(Blanking)

<Core Design>

		Wistron Corporation 21F, 88, Sec. 1, Hsin Tai Wu Rd., Hsichih, Taipei Hsien 221, Taiwan, R.O.C.
Title		
RESERVED		
Size	Document Number	Rev
A3	Enrico 14 AMD	A00
Date: Friday, April 22, 2011	Sheet 72	of 109

(Blanking)

<Core Design>

		Wistron Corporation 21F, 88, Sec.1, Hsin Tai Wu Rd., Hsichih, Taipei Hsien 221, Taiwan, R.O.C.	
Title		Reserved	
Size A3	Document Number	Enrico 14 AMD	Rev A00
Date: Friday, April 22, 2011	Sheet	73	of 109

SSID = SDIO

SD/XD/MS Card Reader

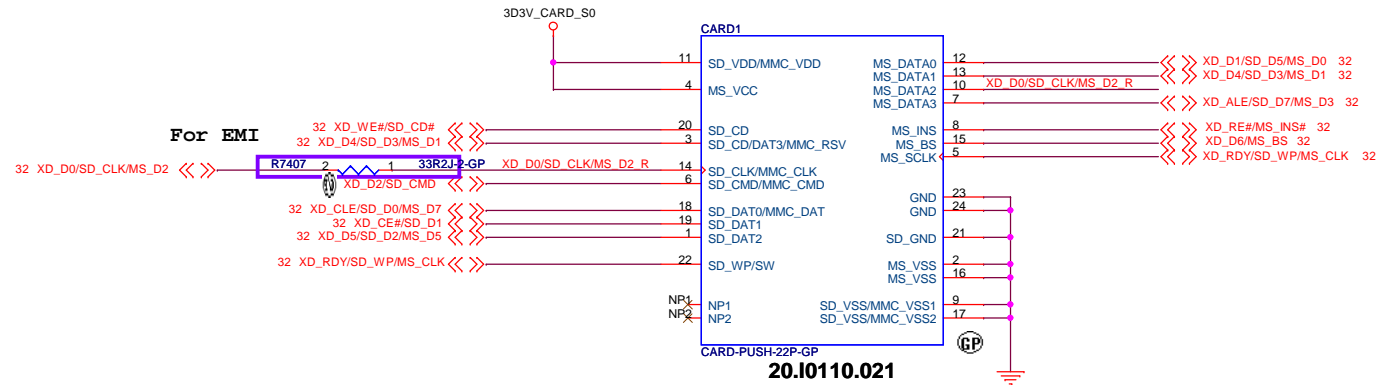
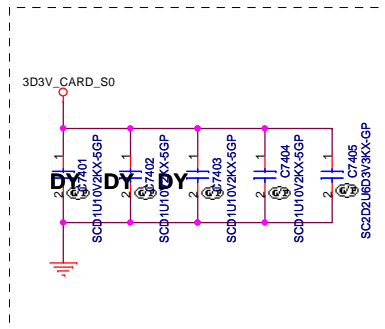

0810 Vendor Recommend

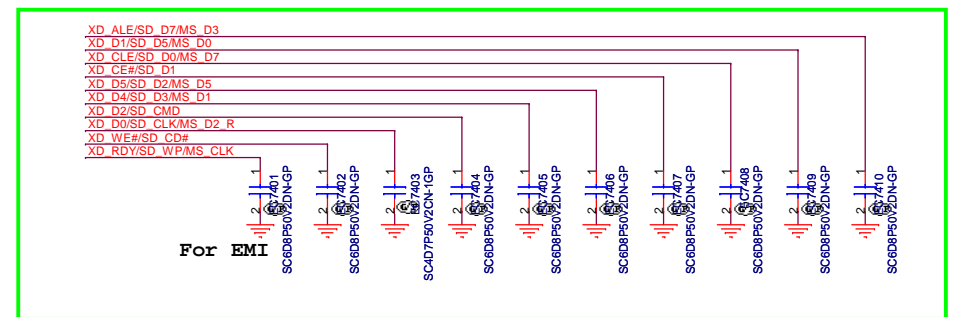

<Core Design>



Title CARD Reader Connector		
Size A3	Document Number Enrico 14 AMD	Rev A00
Date: Friday, April 22, 2011	Sheet 74	of 109

(Blanking)

<Core Design>

		Wistron Corporation 21F, 88, Sec.1, Hsin Tai Wu Rd., Hsichih, Taipei Hsien 221, Taiwan, R.O.C.	
Title			
Express Card			
Size A3	Document Number	Rev	
Enrico 14 AMD		A00	
Date: Friday, April 22, 2011	Sheet 75	of	109

(Blanking)

<Core Design>



Title		
Reserved		
Size A3	Document Number Enrico 14 AMD	Rev A00
Date: Friday, April 22, 2011	Sheet 76 of	109

(Blanking)

<Core Design>

DELL **Wistron Corporation**
21F, 88, Sec.1, Hsin Tai Wu Rd., Hsichih,
Taipei Hsien 221, Taiwan, R.O.C.

Title		
Reserved		
Size	Document Number	Rev
A3	Enrico 14 AMD	A00
Date: Friday, April 22, 2011	Sheet 77 of	109

(Blanking)

<Core Design>

		Wistron Corporation 21F, 88, Sec.1, Hsin Tai Wu Rd., Hsichih, Taipei Hsien 221, Taiwan, R.O.C.
Title		
Reserved		
Size A4	Document Number Enrico 14 AMD	Rev A00
Date: Friday, April 22, 2011	Sheet 78	of 109

(Blanking)

<Core Design>

		Wistron Corporation 21F, 88, Sec.1, Hsin Tai Wu Rd., Hsichih, Taipei Hsien 221, Taiwan, R.O.C.	
Title		Reserved	
Size A3	Document Number	Enrico 14 AMD	Rev A00
Date: Friday, April 22, 2011	Sheet	79	of 109

(Blanking)

<Core Design>

		Wistron Corporation 21F, 88, Sec.1, Hsin Tai Wu Rd., Hsichih, Taipei Hsien 221, Taiwan, R.O.C.
Title		
Reserved		
Size A3	Document Number Enrico 14 AMD	Rev A00
Date: Friday, April 22, 2011	Sheet 80 of 109	

(Blanking)

<Core Design>

		Wistron Corporation 21F, 88, Sec.1, Hsin Tai Wu Rd., Hsichih, Taipei Hsien 221, Taiwan, R.O.C.	
Title			
UNUSED PARTS/EMI Capacitors			
Size	Document Number	Rev	
A3	Enrico 14 AMD	A00	
Date: Friday, April 22, 2011	Sheet 81	of	109

X02

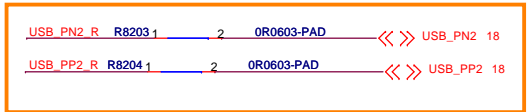

SSID = USB

X02

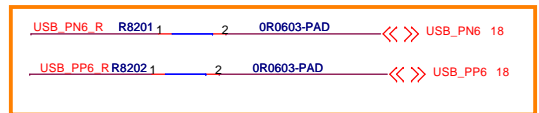

SSID = AUDIO

X01

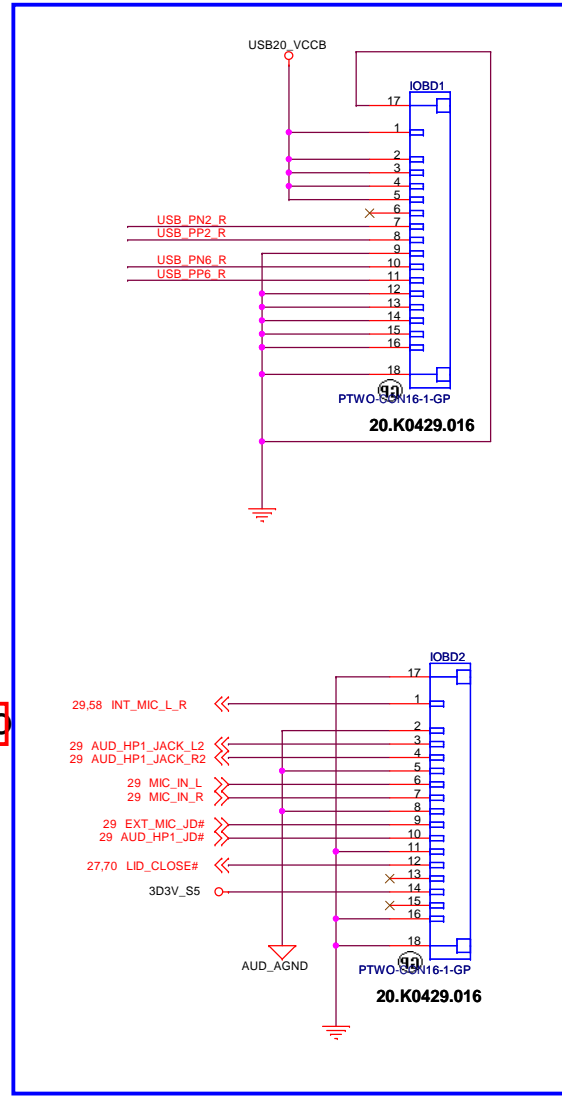

<Core Design>

DELL		Wistron Corporation	
		21F, 88, Sec.1, Hsin Tai Wu Rd., Hsichih, Taipei Hsien 221, Taiwan, R.O.C.	
Title			
IO Board Connector			
Size	Document Number	Rev	
A3	Enrico 14 AMD	A00	
Date:	Friday, April 22, 2011	Sheet	82 of 109

SSID = VIDEO

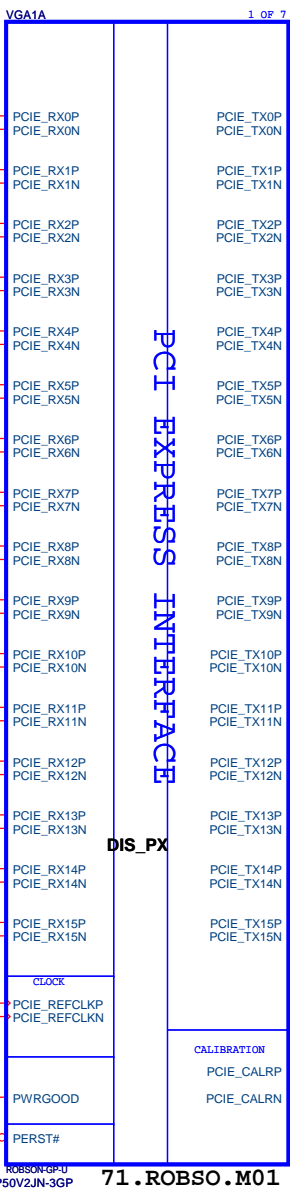

2010/06/10
Move CAPs close to CPU

Colay with Seymour-XT-S3
(71.SEYMR.M01)

CONFIGURATION STRAPS

ALLOW FOR PULLUP PADS FOR THESE STRAPS AND IF THESE GPIOs ARE USED, THEY MUST NOT CONFLICT DURING RESET

STRAPS	PIN	DESCRIPTION OF DEFAULT SETTINGS	RECOMMEND	PLATFORM SETTING
TX_PWRS_ENB	GPIO0	Transmitter Power Savings Enable 0: 50% Tx output swing 1: Full Tx output swing	X	1
TX_DEEMPH_EN	GPIO1	PCIE TRANSMITTER DE-EMPHASIS ENABLED 0:Tx de-emphasis disabled 1:Tx de-emphasis enabled	X	1
BIF_GEN2_EN_A	GPIO2	0:Advertises the PCIe device as 2.5GT/s capable at power on. 1:Advertises the PCIe device as 5.0GT/s capable at power on.	0	0
GPIO5_AC_BATT	GPIO5	optional input allow the system to request a fast power reduction by setting GPIO5 to low.	?	0
GPIO8_ROMSO	GPIO8	RESERVED	0	0
VGA_DIS	GPIO9	0:VGA Controller capacity enabled 1:The device won't be recognized as the system's VGA controller	0	0
ROMIDCFG[2:0]	GPIO[13:11]	BIOS_ROM_EN=1, Config[2:0] defines the ROM type BIOS_ROM_EN=0, Config[2:0] defines the primary memory aperture size	X X X	0 0 1 (256MB)
GPIO21_BB_EN	GPIO21	RESERVED	0	0
BIOS_ROM_EN	GPIO_22_ROMCSB	0:Disable external BIOS ROM device 1:Enable external BIOS ROM device	X	0
VIP_DEVICE_STRAP_EN	V2SYNC	VIP Device Strap Enable indicates to the software driver that it sense whether or not a VIP device is connected on the VIP Host interface.	X	0
RSVD	H2SYNC	RESERVED	0	0
RSVD	GENERICC	RESERVED	0	0
AUD[1]	HSYNC	AUD[1:0]:11-Audio for both DisplayPort and HDMI	X	1
AUD[0]	VSYSN		X	1

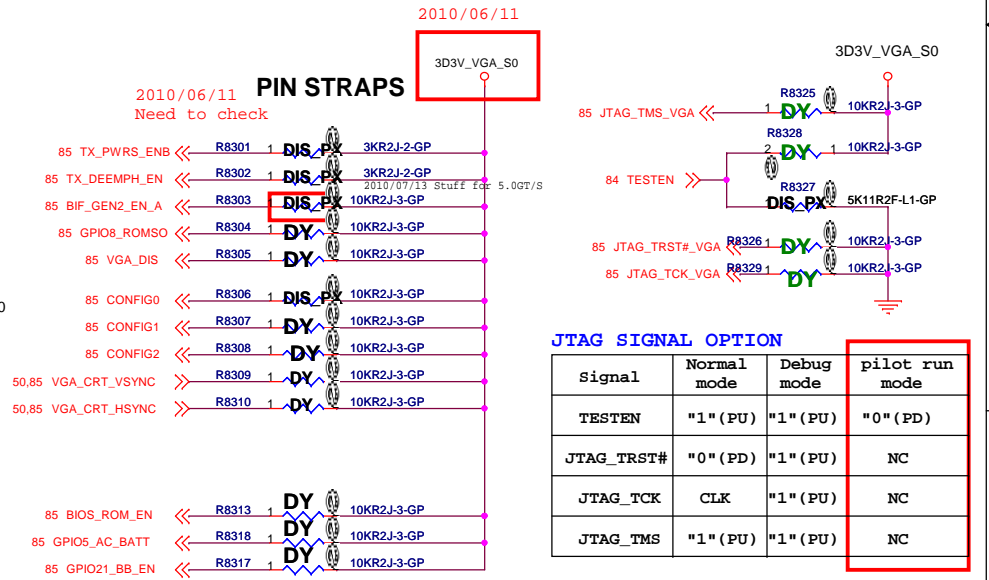
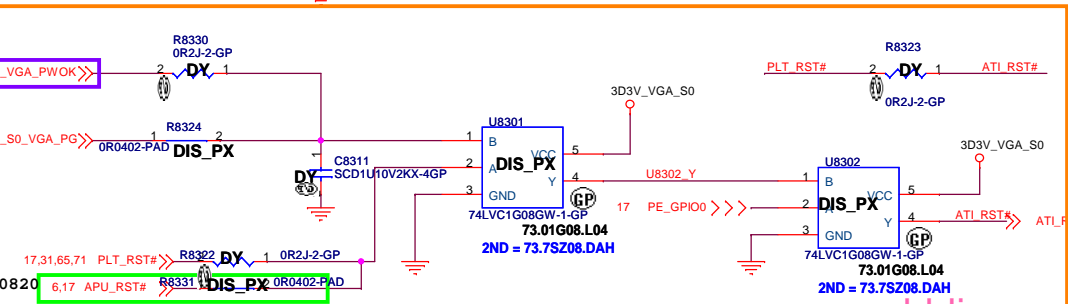

<Core Design>

Wistron Corporation
21F, 88, Sec.1, Hsin Tai Wu Rd., Hsichih, Taipei Hsien 221, Taiwan, R.O.C.

File: **GPU PEG/STRAPPING(1/5)**

Size: **A3** Document Number: **Enrico 14 AMD** Rev: **A00**

Date: Friday, April 22, 2011 Sheet 83 of 109

SSID = VIDEO

PLACE MVREF DIVIDERS AND CAPS CLOSE TO ASIC

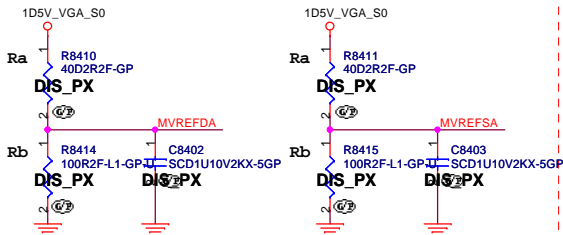

DDR3/GDDR3 Memory Stuff Option (ROBSON-S3/SEYMOUR-XT-S3)

	DDR5	DDR3
MVDDQ	1.5V	1.5V/1.8V
Ra	40.2R	40.2R
Rb	100R	100R

DPC_CALR (Park/Robson-S3):
Analog calibration.
Connect DPxx_CALR to GND through a 150-Ω (1%) resistor.



**This basic topology should be used for DRAM_RST for DDR3/GDDR3/GDDR5. These Capacitors and Resistor values are an example only. The Series R and || Cap values will depend on the DRAM load and will have to be calculated for different Memory ,DRAM Load and board to pass Reset Signal Spec.

Designator	For SEYMOUR	For Robson
R_MEM_1	10R	10R
R_MEM_2	50R	50R
R_MEM_3	5K	5K
C_MEM	120pF	120pF

Place all these components very close to GPU (Within 25mm) and keep all component close to each Other (within 5mm) except R_MEM_2

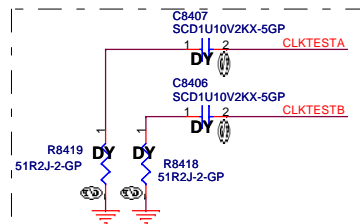
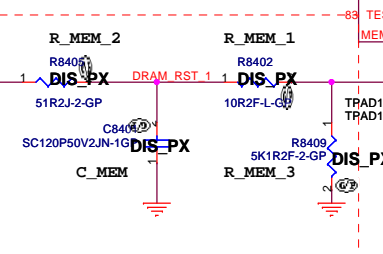

For normal GPU operation, these signals can be left floating (do not populate the capacitors and resistors).

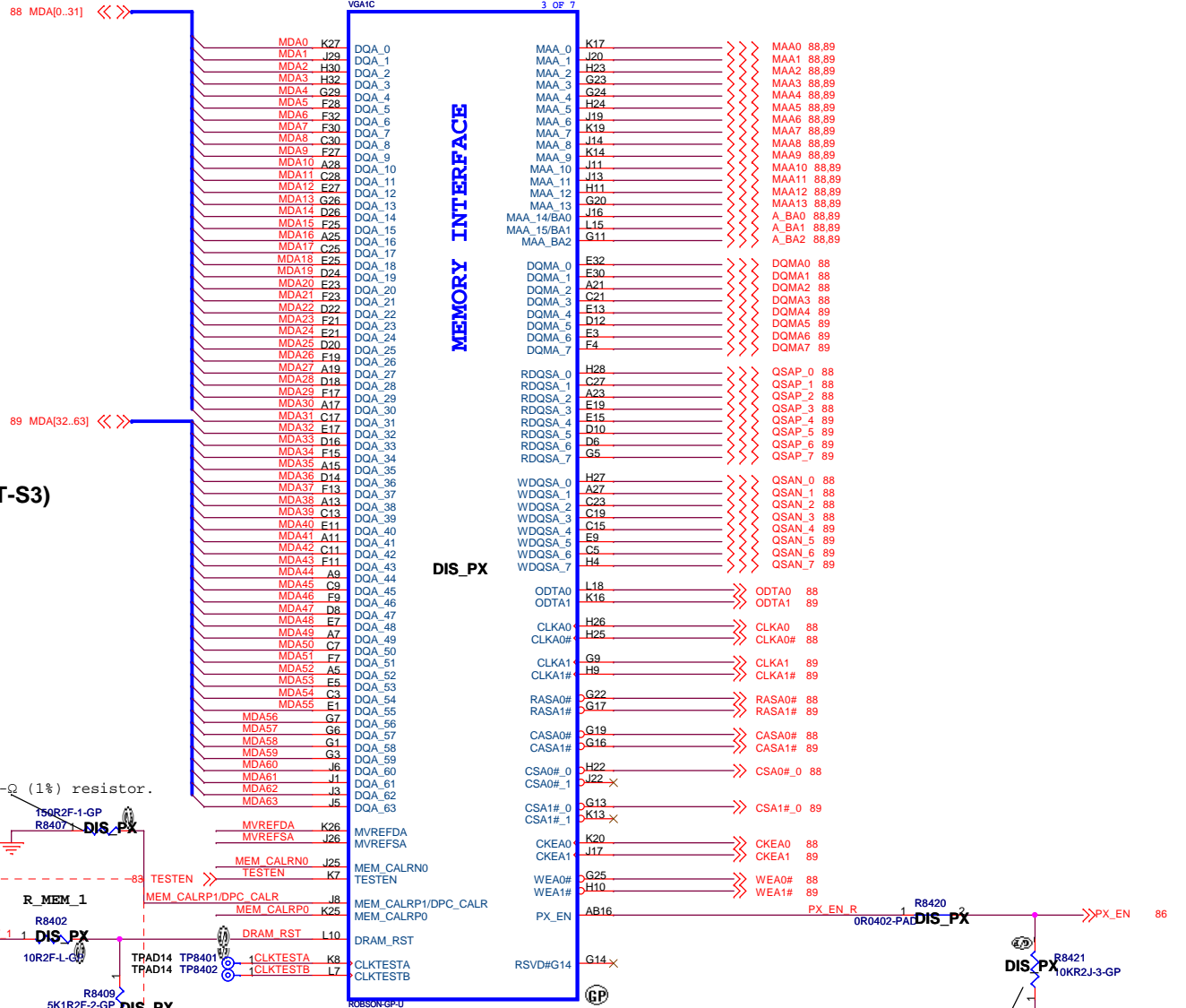

71.ROBSO.M01 Colay with Seymour-XT-S3 (71.SEYMR.M01)

2010/07/06
Schematics check list:
A pull-down resistor is required.

<Core Design>

Wistron Corporation
21F, 88, Sec.1, Hsin Tai Wu Rd., Hsichih, Taipei Hsien 221, Taiwan, R.O.C.

Title: **GPU Memory(2/5)**

Size: **A3** Document Number: **Enrico 14 AMD** Rev: **A00**

Date: Friday, April 22, 2011 Sheet 84 of 109

Memory ID Table

Table with 2 columns: Memory ID (0000-0011) and Description (DDR3 SAMSUNG, Hynix, etc.)

SSID = VIDEO

LVDS Interface

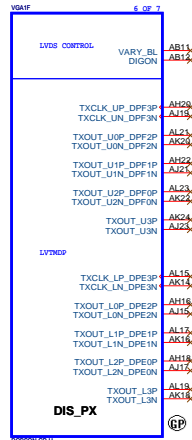

For Seymour, DPC_VDD18 = DPC_VDD18 2010/06/11

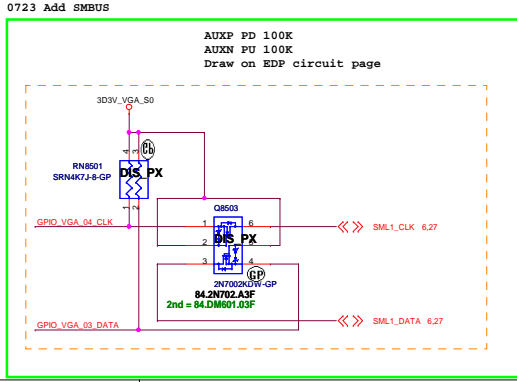
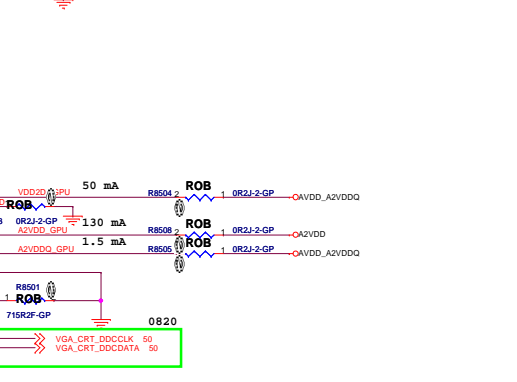
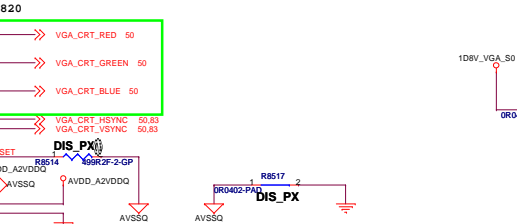
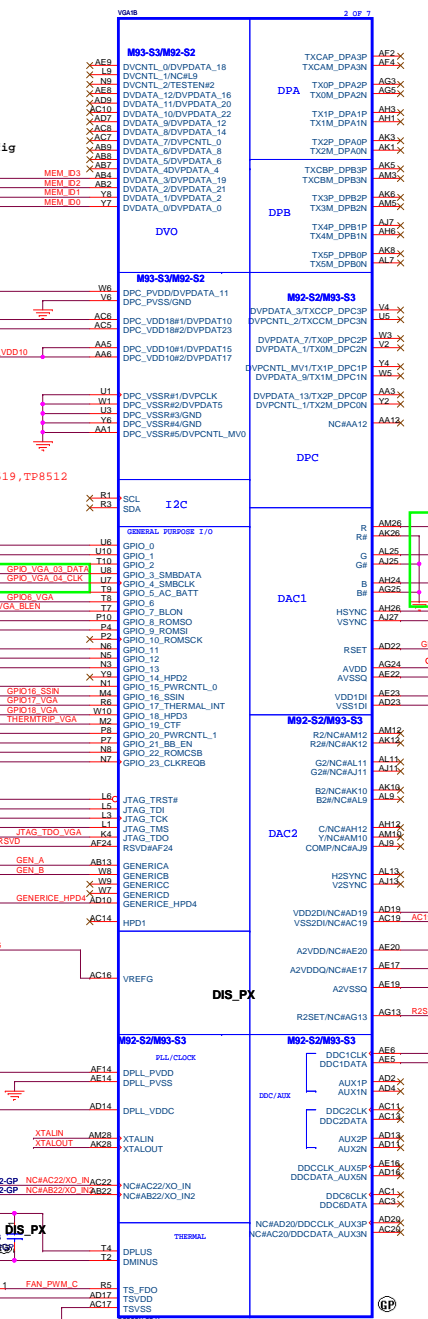
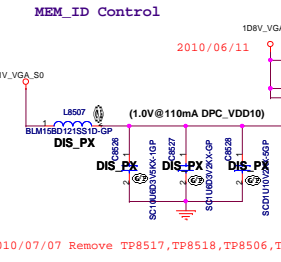
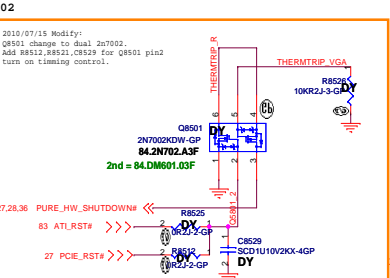

71.ROBSO.M01

XO1

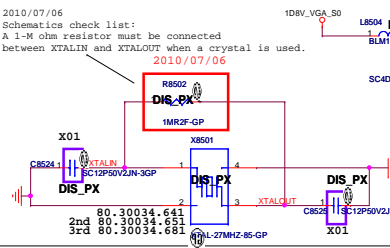
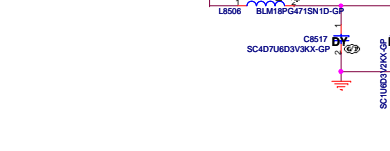
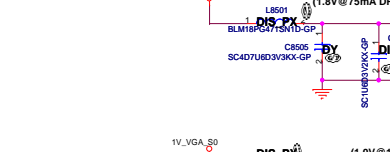
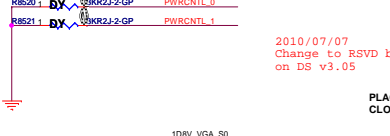
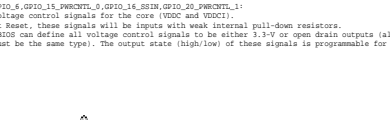
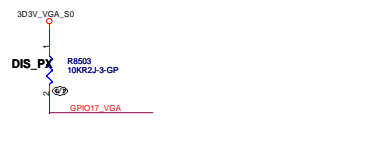

71.ROBSO.M01 Colay with Seymour-XT-S3 (71.SEYMR.M01)

- 27MHz crystal connected to XTALIN or XTALOUT
27MHz (1.8V) oscillator connected to XTALIN
27MHz (3.3V) oscillator connected to XO_IN

DELL Wistron Corporation GPU_DP/LVDS/CRT/GPIO(3/5) Enrico 14 AMD

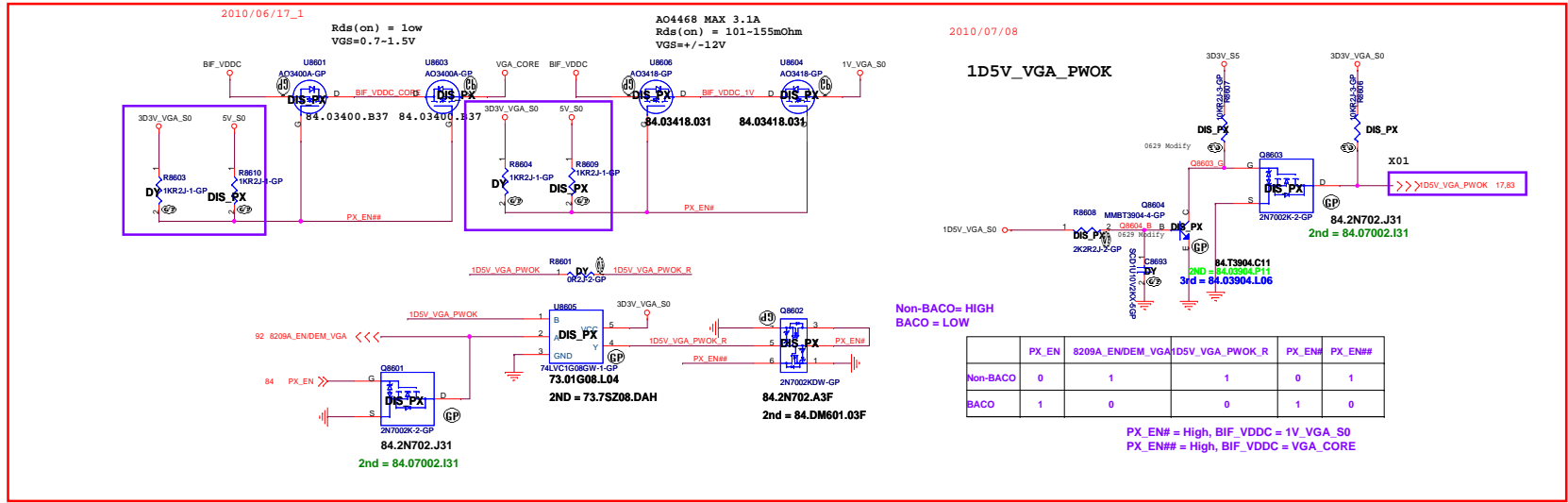
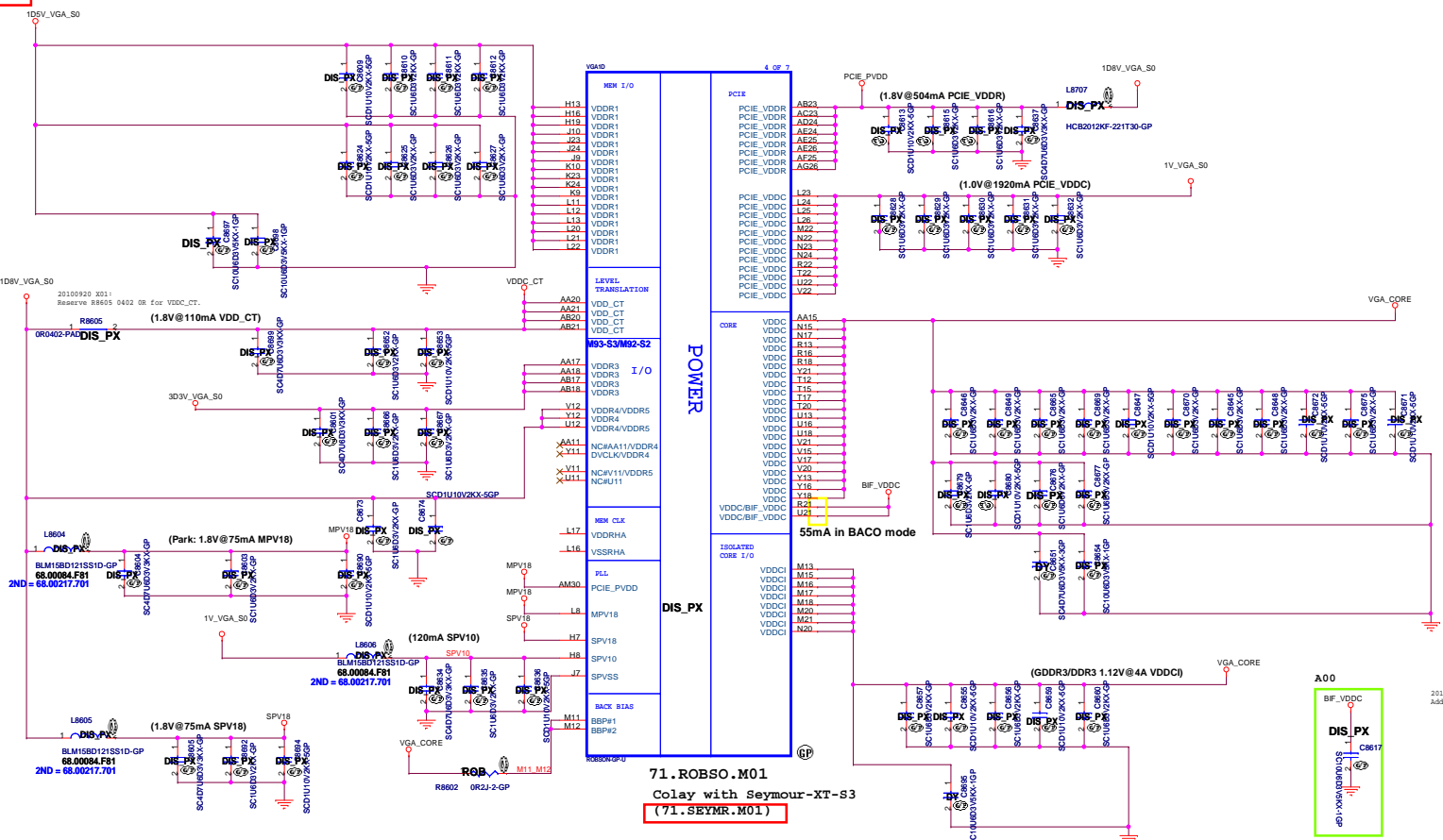

SSID = VIDEO

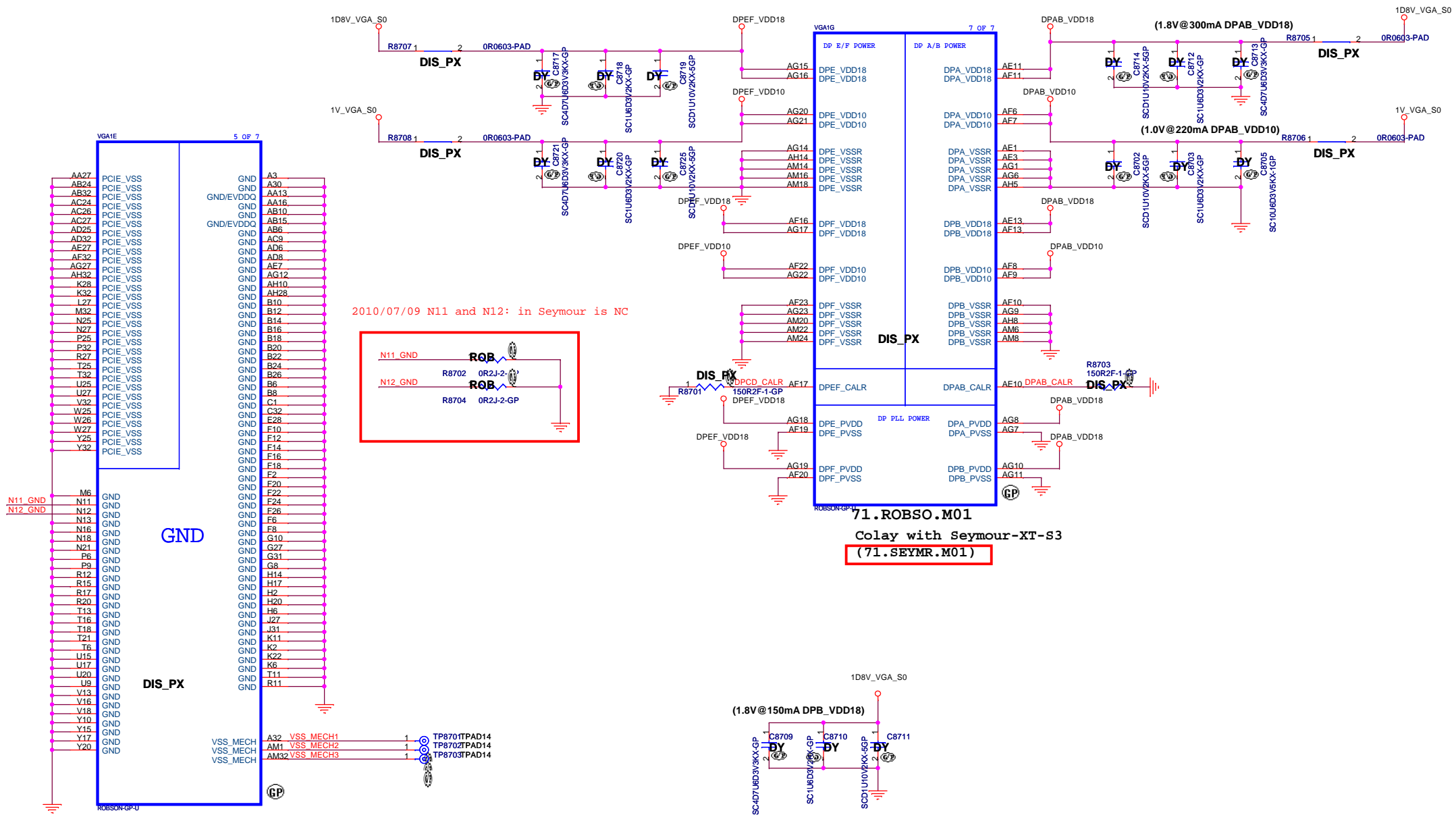

2010/07/09 N11 and N12: in Seymour is NC

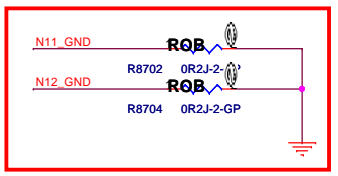

71.ROBSO.M01

71.ROBSO.M01
Colay with Seymour-XT-S3
(71.SEYMR.M01)

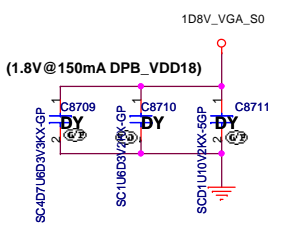

<Core Design>
DELL Wistron Corporation
21F, 88, Sec.1, Hsin Tai Wu Rd., Hsichih, Taipei Hsien 221, Taiwan, R.O.C.
Title: GPU DPPWR/GND(5/5)
Size: A3 Document Number: Enrico 14 AMD Rev: A00
Date: Friday, April 22, 2011 Sheet: 87 of 109

SSID = VIDEO

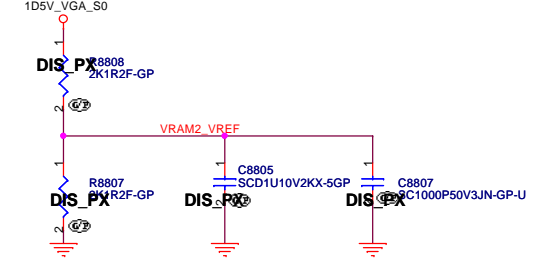
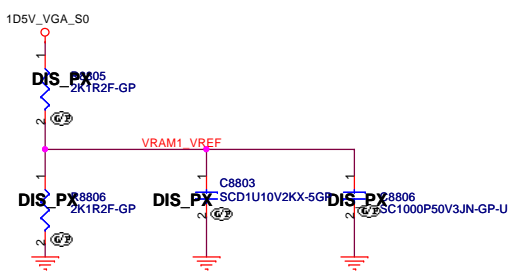
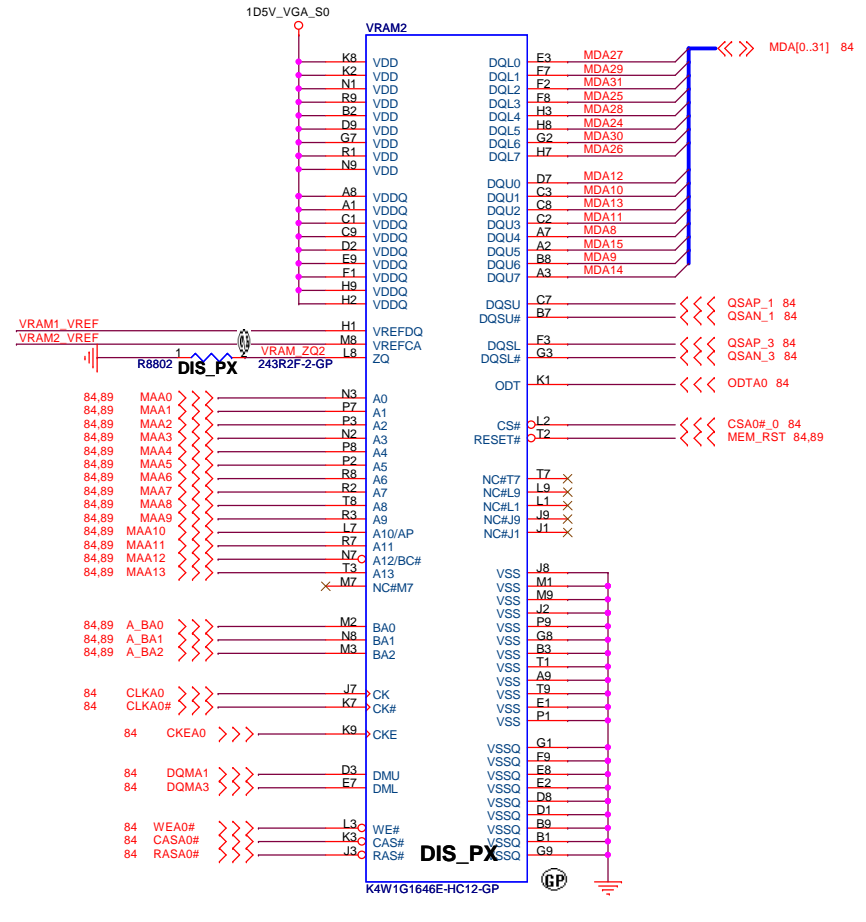
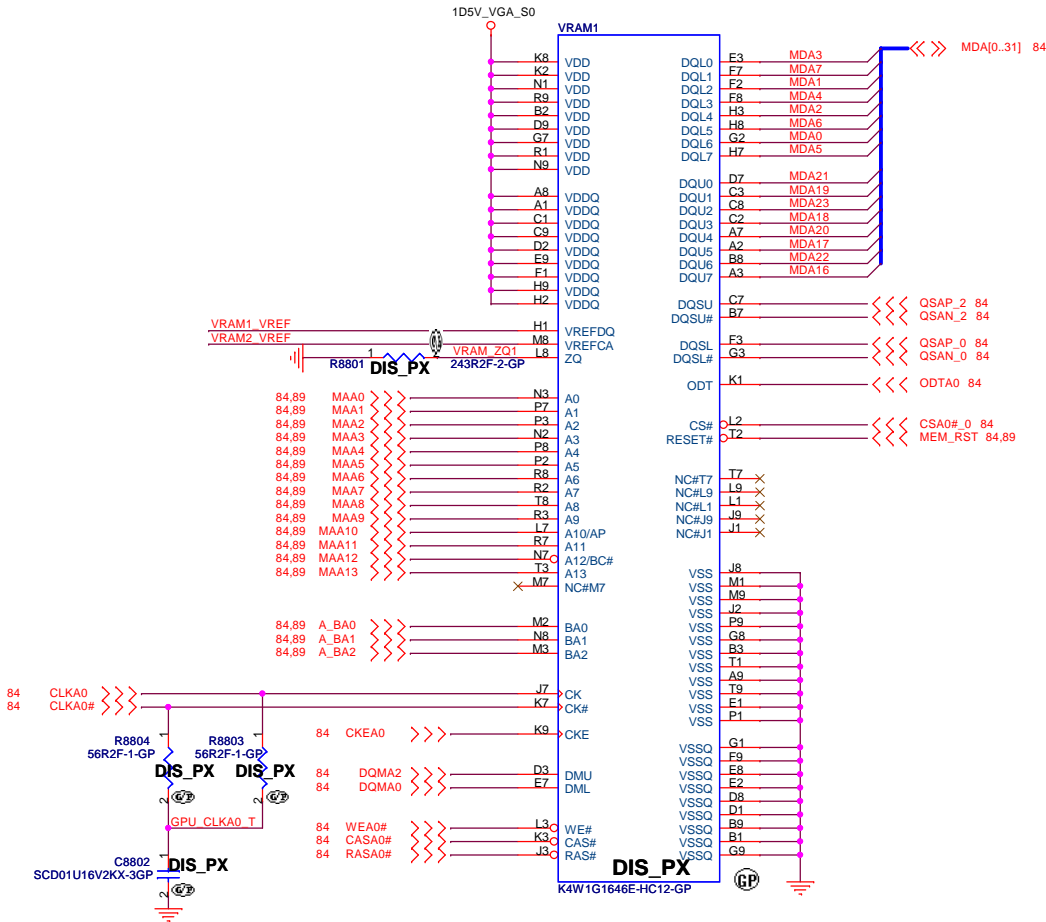

<Core Design>

DELL Wistron Corporation
21F, 88, Sec.1, Hsin Tai Wu Rd., Hsichih, Taipei Hsien 221, Taiwan, R.O.C.

Title: **GPU-VRAM1,2 (1/4)**

Size: A3	Document Number: Enrico 14 AMD	Rev: A00
Date: Friday, April 22, 2011	Sheet: 88	of 109

SSID = VIDEO

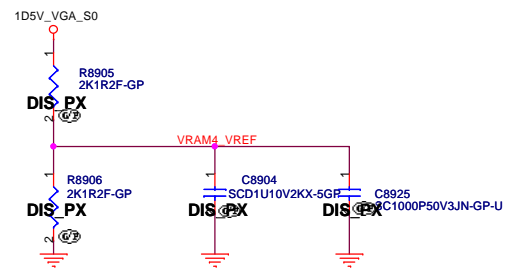
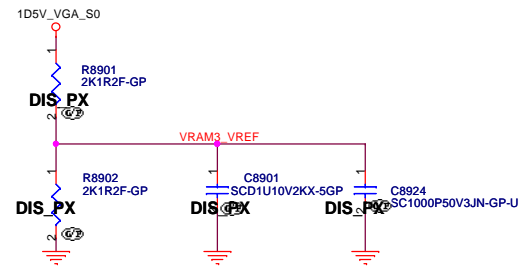
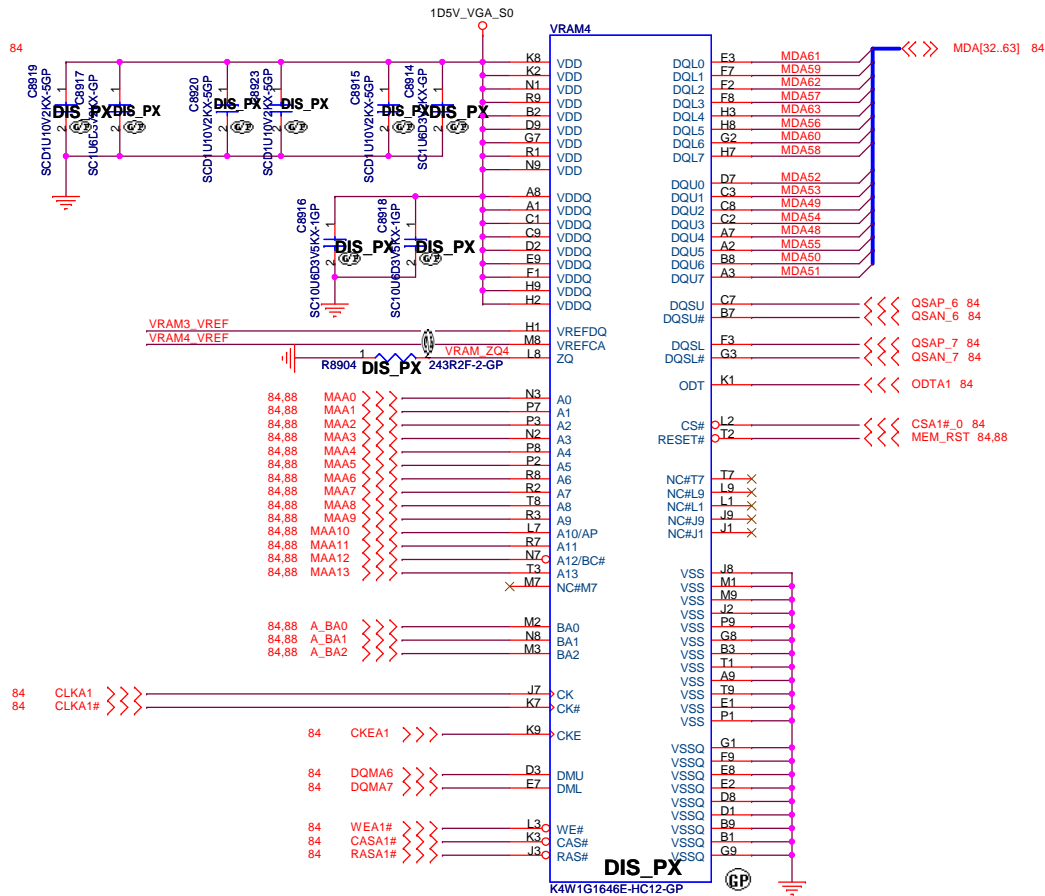
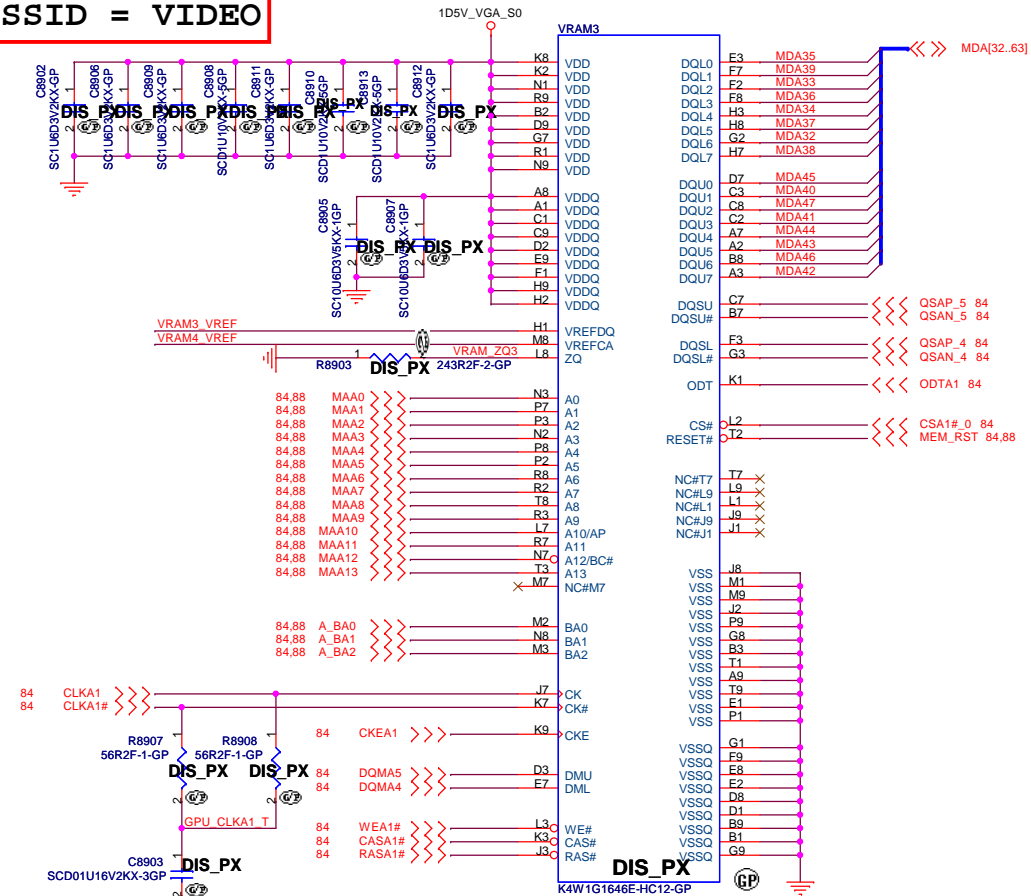

<Core Design>

Wistron Corporation
21F, 88, Sec. 1, Hsin Tai Wu Rd., Hsichih, Taipei Hsien 221, Taiwan, R.O.C.

Title: **GPU-VRAM3,4 (2/4)**

Size A3	Document Number	Rev
	Enrico 14 AMD	A00
Date: Friday, April 22, 2011	Sheet 89 of 109	

(Blanking)

<Core Design>

		Wistron Corporation 21F, 88, Sec. 1, Hsin Tai Wu Rd., Hsichih, Taipei Hsien 221, Taiwan, R.O.C.
Title		
GPU-VRAM5,6 (3/4)		
Size	Document Number	Rev
A3	Enrico 14 AMD	A00
Date: Friday, April 22, 2011	Sheet 90 of 109	1

(Blanking)

<Core Design>



Title		
GPU-VRAM7,8 (4/4)		
Size	Document Number	Rev
A3	Enrico 14 AMD	A00
Date: Friday, April 22, 2011	Sheet 91	of 109

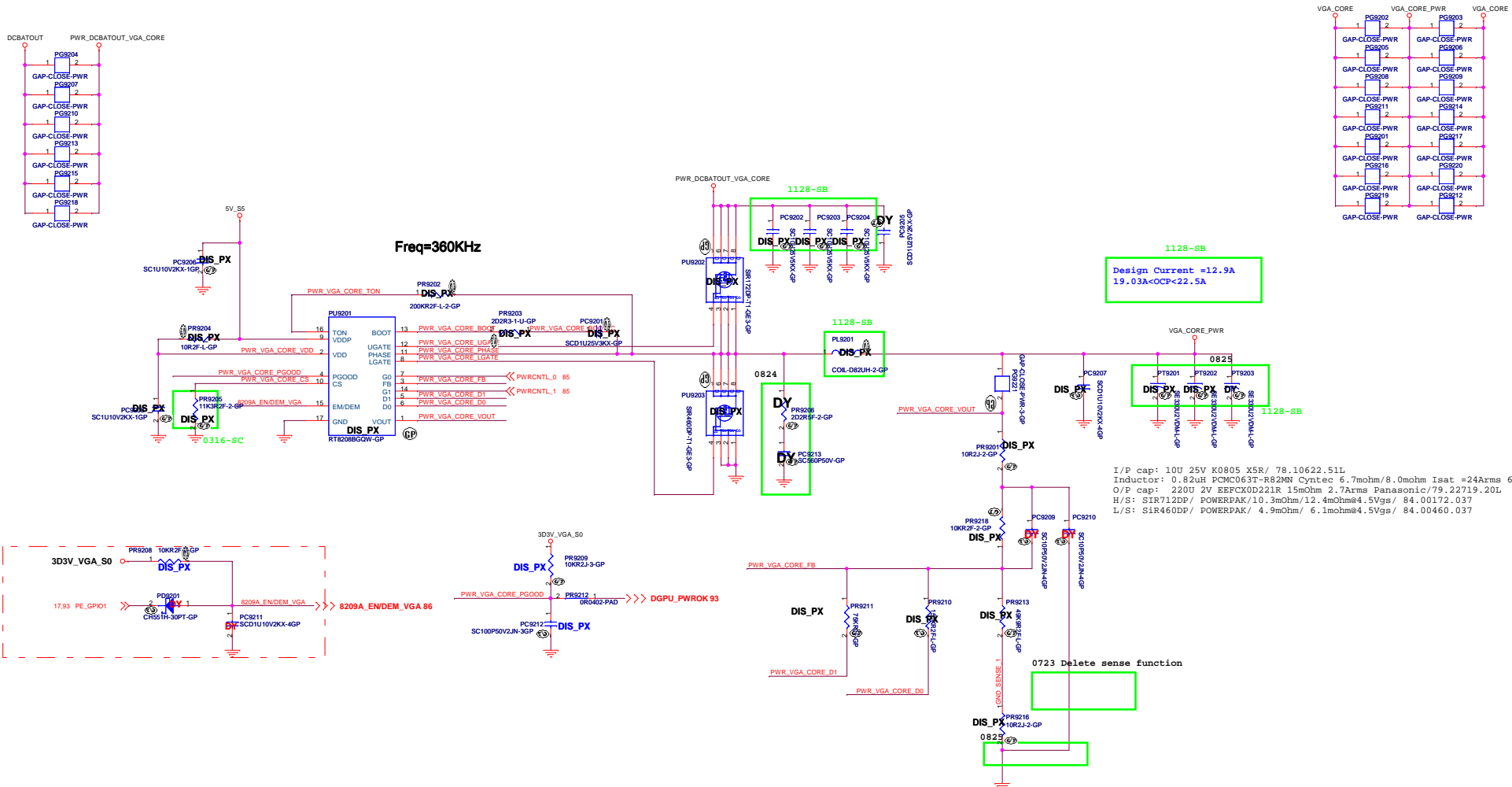

I/P cap: 10U 25V K0805 X5R/ 78.10622.51L
 Inductor: 0.82uH PCMC063T-R82MN Cyntec 6.7mohm/8.0mohm Isat =24Arms 68.R8210.10V
 O/P cap: 220U 2V EEPCK0D221R 15mohm 2.7Arms Panasonic/79.22719.20L
 H/S: SIR122DP/ POWERPAK/10.3mohm/12.4mohm@4.5Vgs/ 84.00172.037
 L/S: SIR460DP/ POWERPAK/ 4.9mohm/ 6.1mohm@4.5Vgs/ 84.00460.037

Robson-XT

PWR_VGA_CORE_D1	PWR_VGA_CORE_D0	VGA_CORE_PWR
L	L	1.12V
L	H	N/A
H	L	0.95V
H	H	0.9V

Vout=0.75V*(R1+R2)/R2
 For ROBSON
 PR9210=44.2K(64.44225.6DL)
 PR9211=150K(64.15035.6DL)

Seymour-XT

PWR_VGA_CORE_D1	PWR_VGA_CORE_D0	VGA_CORE_PWR
L	L	1.05V
L	H	1V
H	L	N/A
H	H	0.9V

Vout=0.75V*(R1+R2)/R2
 For Seymour
 PR9210=150K(64.15035.6DL)
 PR9211=75K(64.75025.6DL)



<Core Design>

Wistron Corporation
 21F, 88, Sec.1, Hsin Tai Wu Rd., Hsinchu, Taipei Hsin 221, Taiwan, R.O.C.

File: RT8208B +VGA CORE
 Size: A2 Document Number: Rev: A00
 Date: Friday, April 22, 2011 Enrico 14 AMD
 Sheet: 92 of 108

+3VS to 3.3V_DELAY Transfer

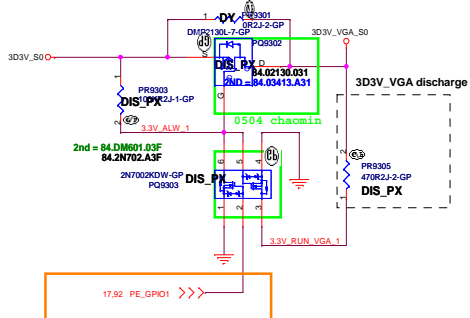

Different To Intel, AMD Is High Active

	PE_GPI00	PE_GPI01
dGPU mode	H	H
IGPU	L	L
IGPU with BACO	H	H

1D8V_VGA_S0

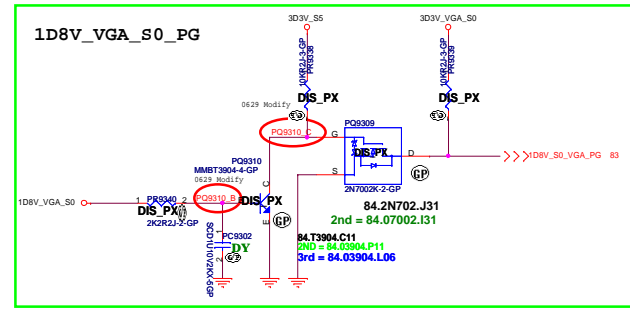
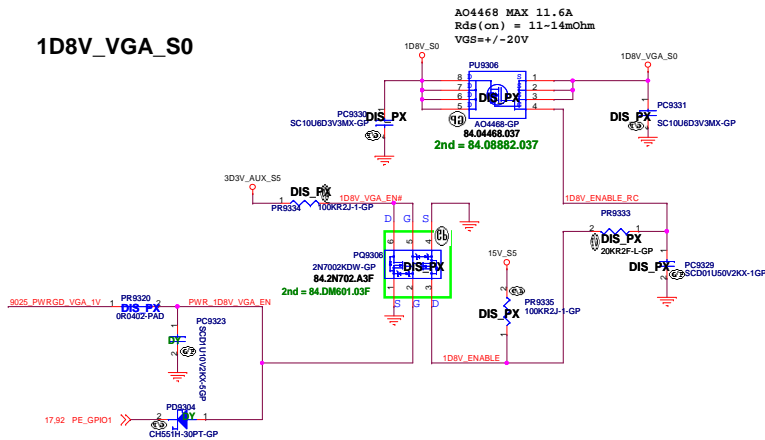

1D5V_VGA_S0

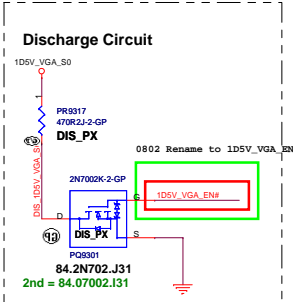
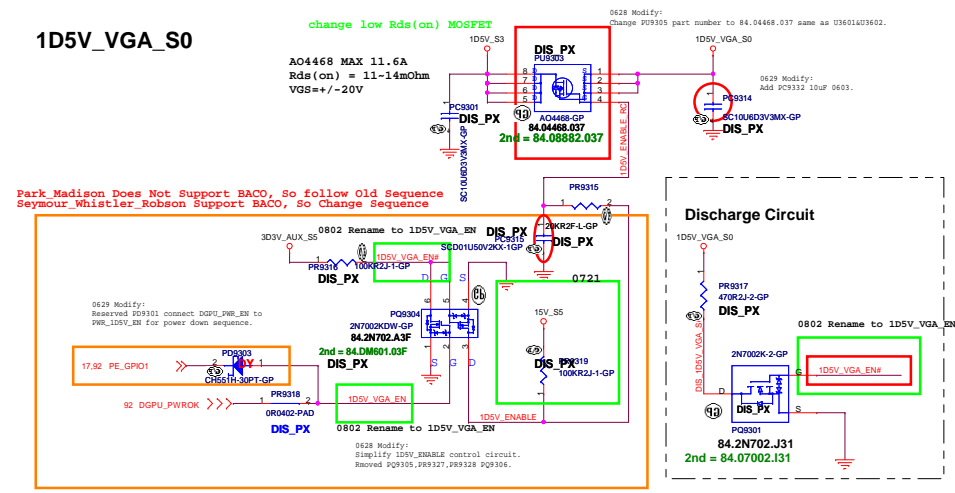

Park_Madison Does Not Support BACO, So follow Old Sequence
 Seymour_Whistler_Robson Support BACO, So Change Sequence
 3D3V_VGA_S0 should ramp-up before VGA_Core
 VGA_Cores should ramp-up before 1V_VGA_S0
 1V_VGA_S0 should ramp up before 1D8V_VGA_S0
 so 1V_VGA_S0 EN have to fine tune RC delay after VGA_Core

RT9025 for 1V_VGA_S0

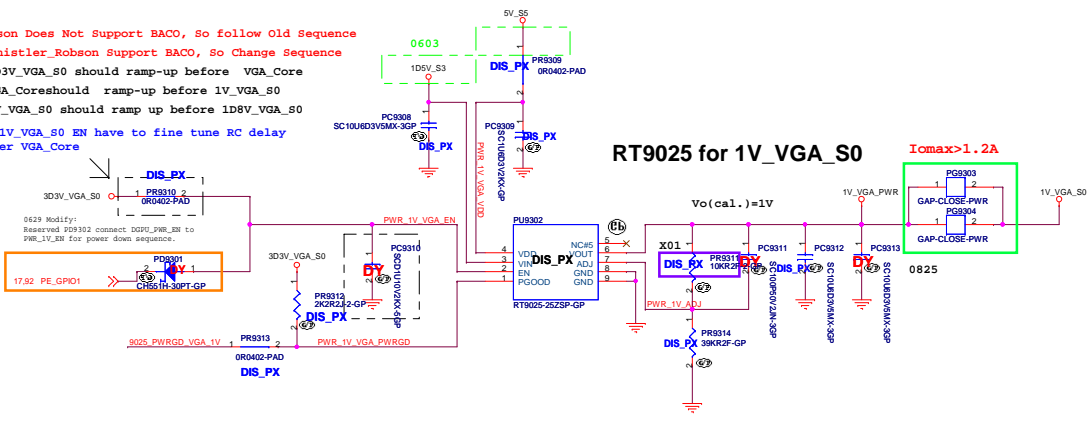

<Core Design>

Wistron Corporation
 21F, 68, Sec. 1, Hsin Tai Wu Rd., Hsinchu, Taipei Hsin 221, Taiwan, R.O.C.

File: **DISCRETE VGA POWER**

Size A2	Document Number Enrico 14 AMD	Rev A00
Date: Friday, April 22, 2011	Sheet 93 of 109	

SSID = VIDEO

<Core Design>

		Wistron Corporation 21F, 88, Sec.1, Hsin Tai Wu Rd., Hsichih, Taipei Hsien 221, Taiwan, R.O.C.	
Title			
LVDS Switch			
Size	Document Number	Rev	
	Enrico 14 AMD	A00	
Date: Friday, April 22, 2011		Sheet 94	of 109

(Blanking)



(Blanking)

<Core Design>

		Wistron Corporation 21F, 88, Sec.1, Hsin Tai Wu Rd., Hsichih, Taipei Hsien 221, Taiwan, R.O.C.
Title		
Touch Panel		
Size	Document Number	Rev
A3	Enrico 14 AMD	A00
Date: Friday, April 22, 2011	Sheet 96 of 109	

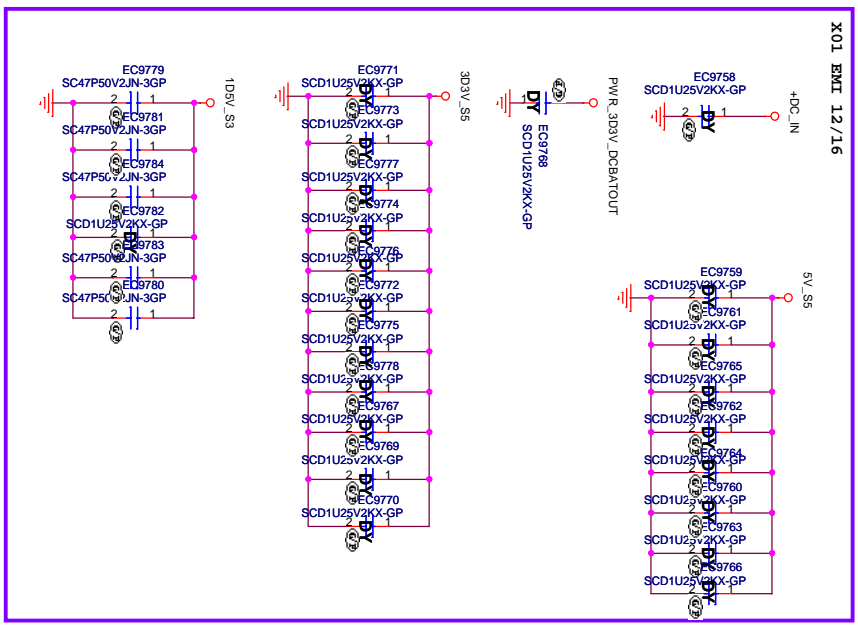
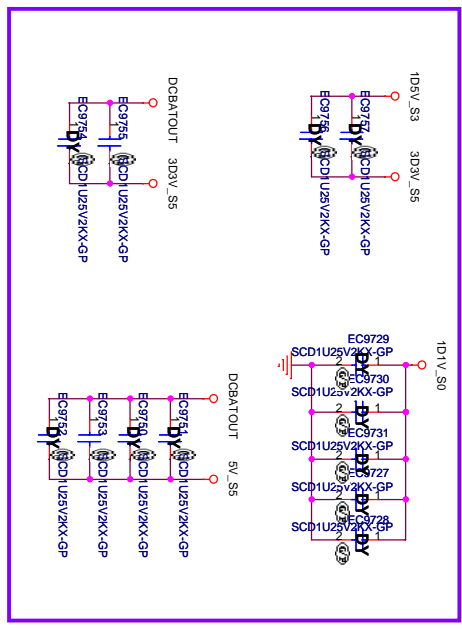
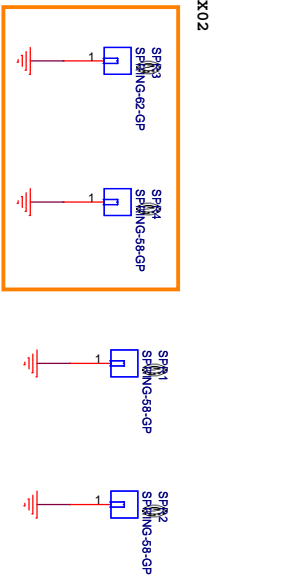
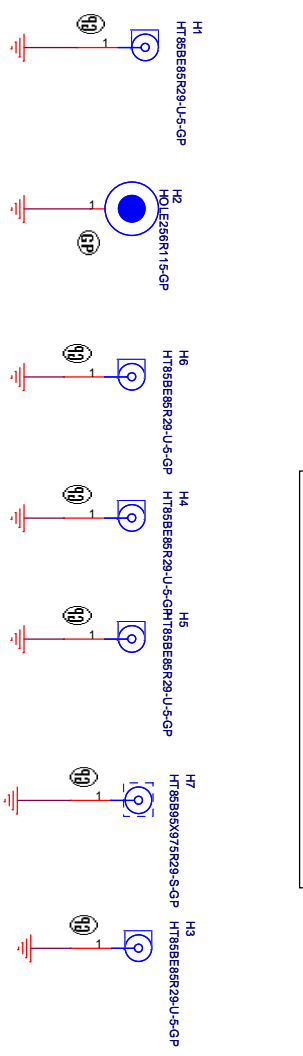
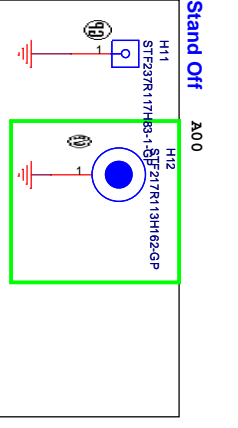
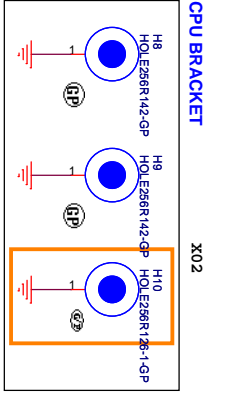
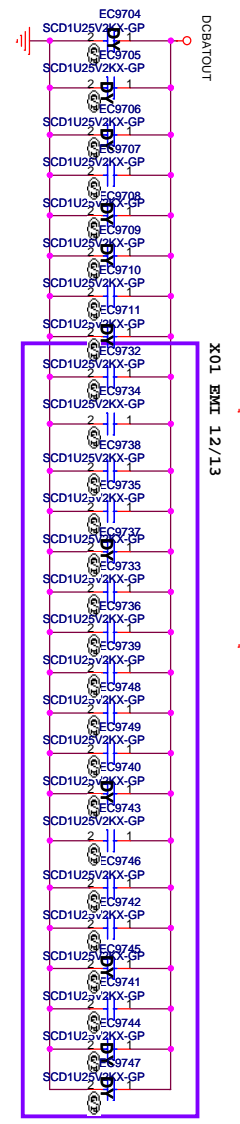
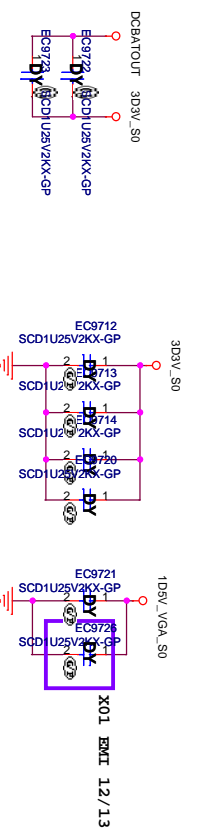
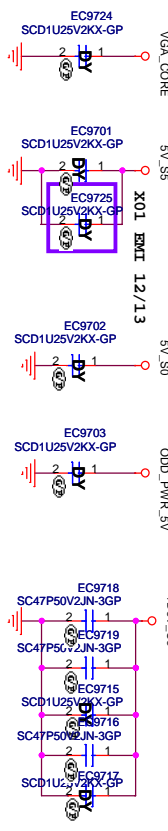

Wistron Corporation
21F, 88, Sec.1, Hsin Tai Wu Rd., Hsinchu, Taipei Hsin 221, Taiwan, R.O.C.

DEL

UNUSED PARTS/CAP

Entico 14 AMD

Document Number: Entico 14 AMD

Rev: A00

Date: Feb, April 22, 2011

Sheet: 97 of 108

Thermal Block Diagram

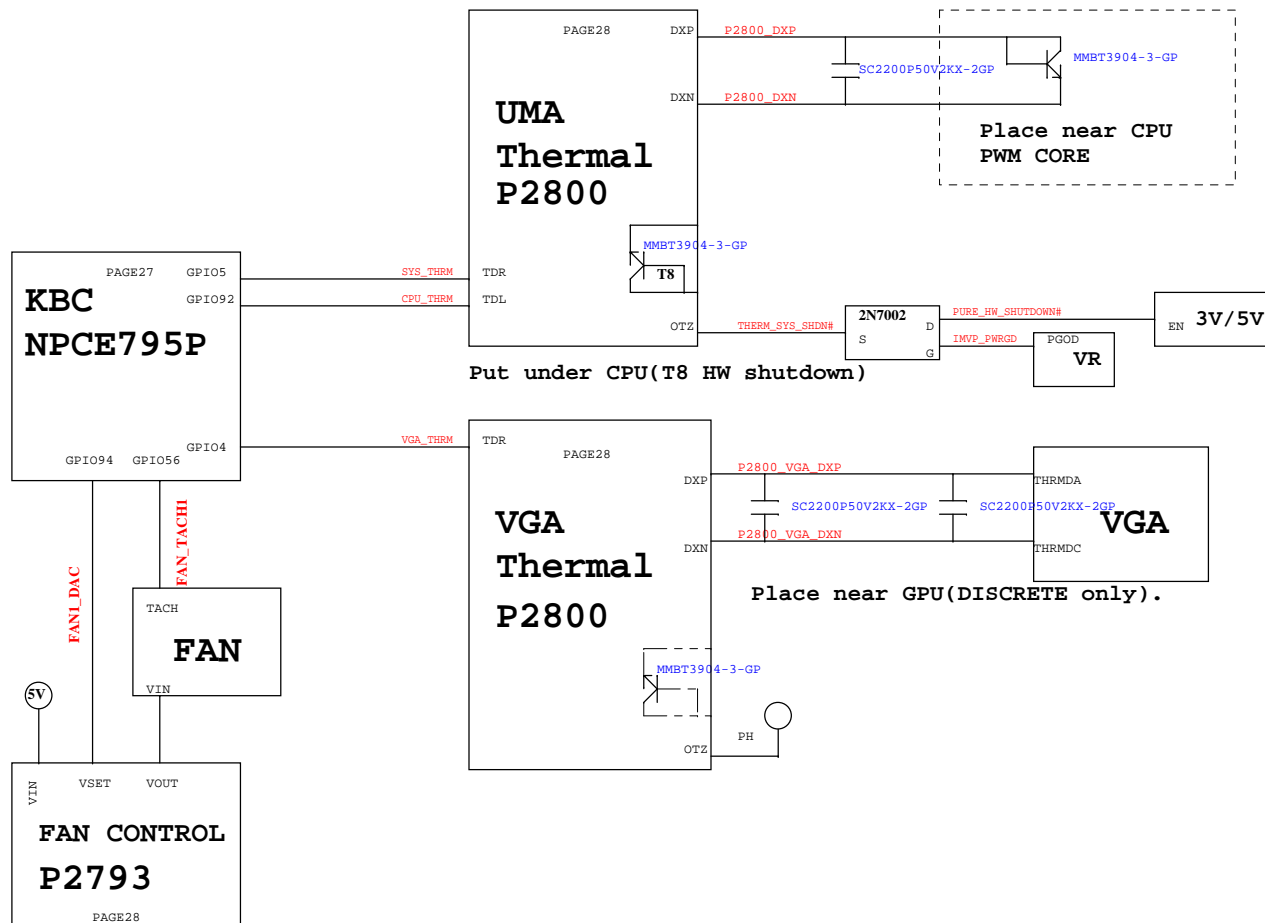

Audio Block Diagram

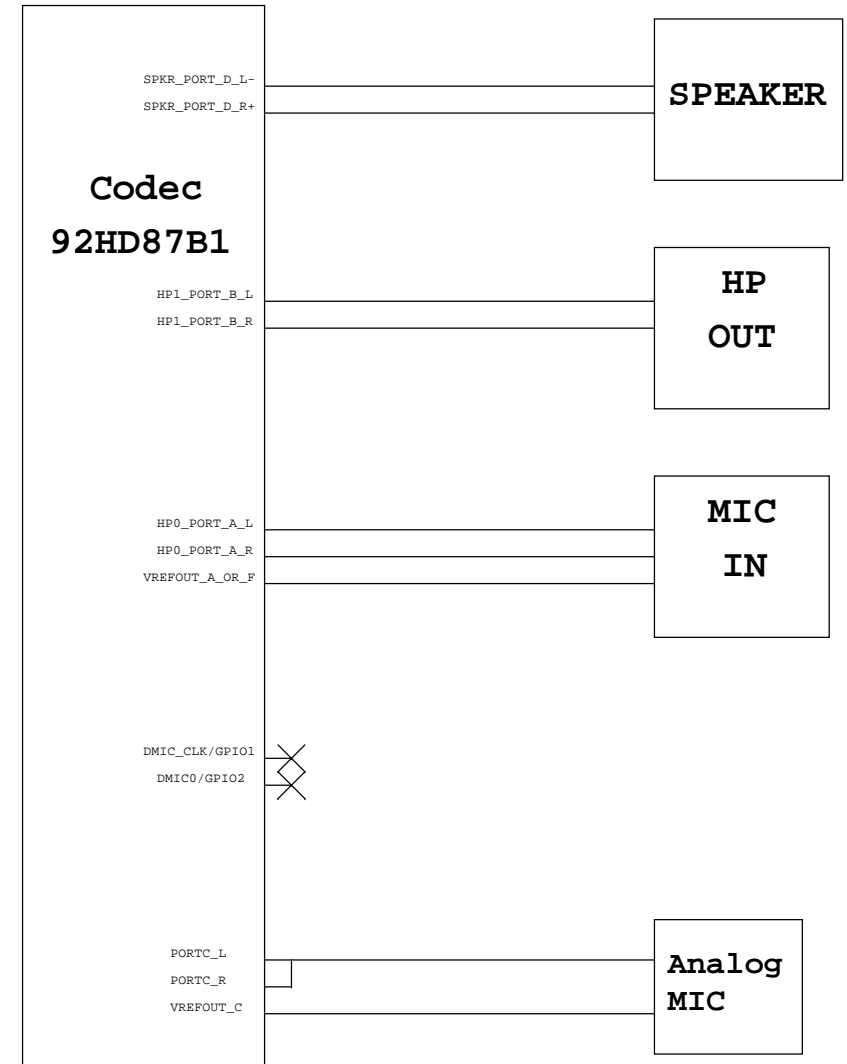

<Core Design>

DELL Wistron Corporation
21F, 88, Sec. 1, Hsin Tai Wu Rd., Hsichih, Taipei Hsien 221, Taiwan, R.O.C.

Title: **THERMAL/AUDIO BLOCK DIAGRAM**

Size: A3	Document Number: Enrico 14 AMD	Rev: A00
Date: Friday, April 22, 2011	Sheet: 98 of 109	

POWER SEQUENCE

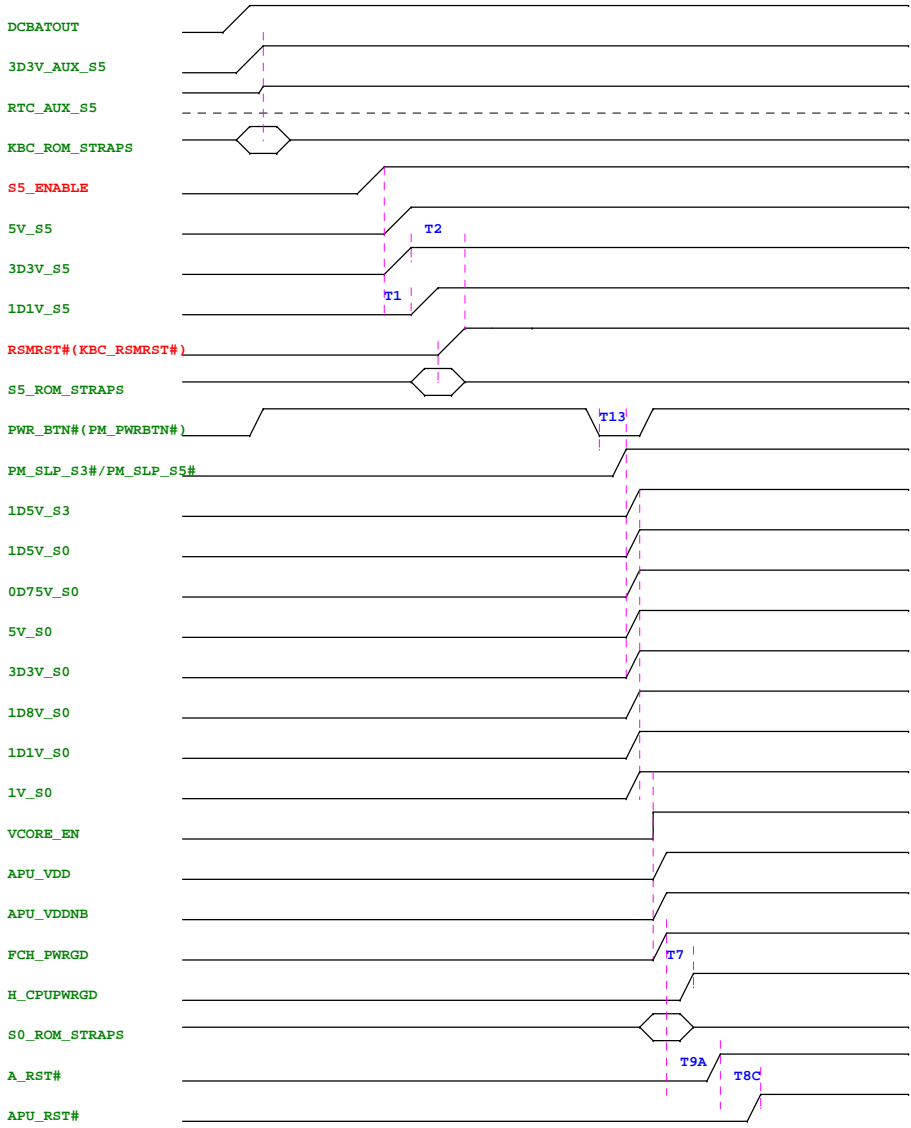

	Min	Max	Description
T1	-	-	+3.3V_S5 to +1.1V_S5
T2	10 ms	-	+3.3V_S5 to resume reset (RSMRST#).
T7	98 ms	150 ms	FCH_PWRGOOD assertion to LDT_PG assertion delay.
T8C	1.0 ms	2.3 ms	PCIRST# to LDT_RST#.
T9A	101 ms	113 ms	FCH_PWR_GOOD to A_RST#.
T13	8 ns	-	PwrButton to SLP_S3# / SLP_S5# de-assertion

<Core Design>

Wistron Corporation
 21F, 88, Sec. 1, Hsin Tai Wu Rd., Hsichih,
 Taipei Hsien 221, Taiwan, R.O.C.

Title: **POWER SEQUENCE**

Size: A3	Document Number: Enrico 14 AMD	Rev: A00
Date: Friday, April 22, 2011	Sheet: 99	of: 109

Power Delivery Block Diagram

Power Shape

Regulator

LDO

Switch

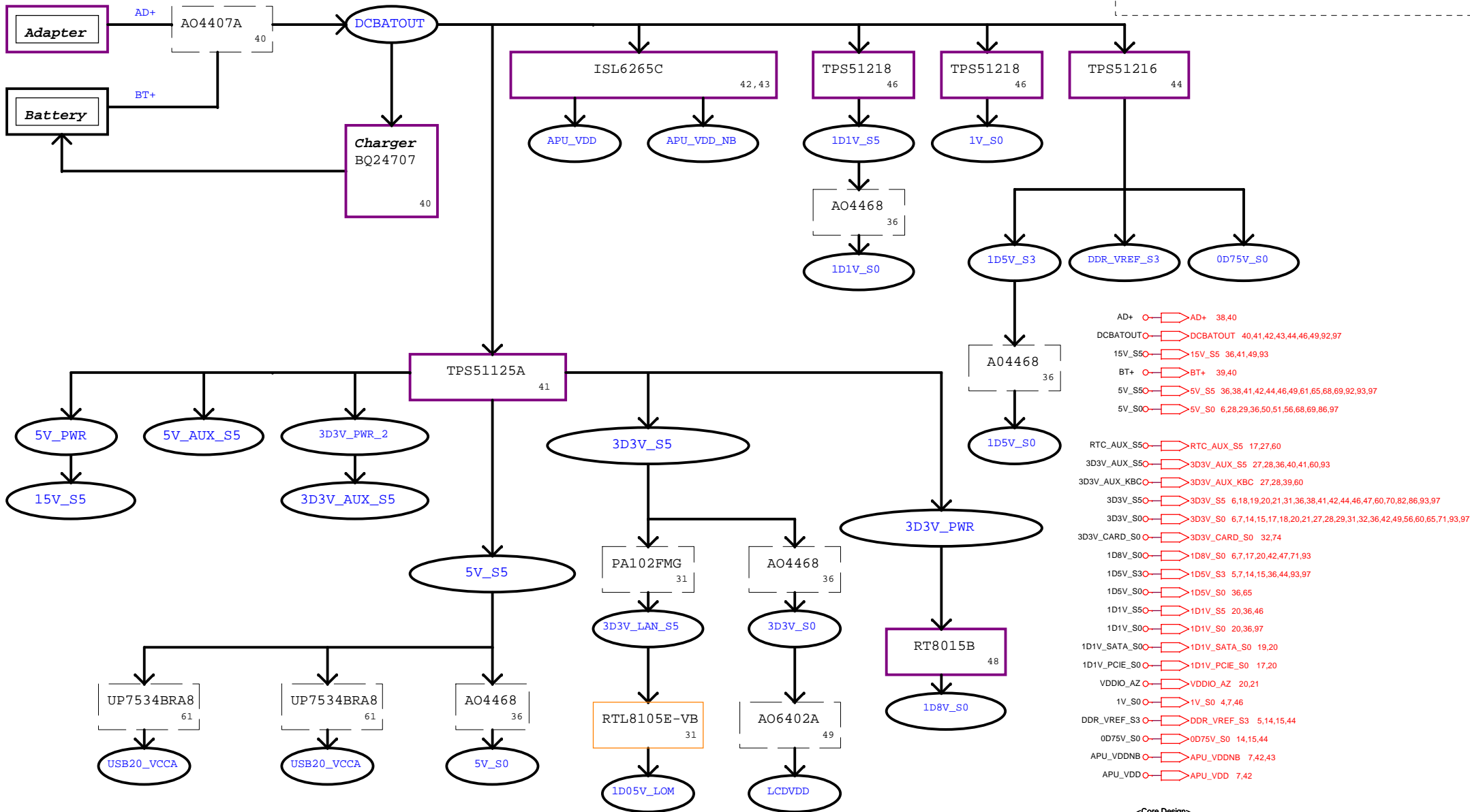

<Core Design>

DELL		Wistron Corporation	
		21F, 88, Sec. 1, Hsin Tai Wu Rd., Hsichih, Taipei Hsien 221, Taiwan, R.O.C.	
Title: Power Block Diagram			
Size: A3	Document Number: Enrico 14 AMD	Rev: A00	
Date: Friday, April 22, 2011	Sheet: 100	of	109

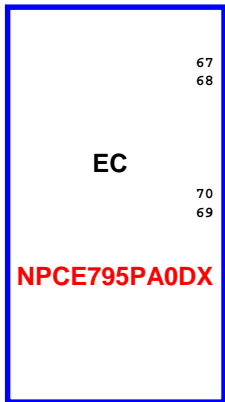
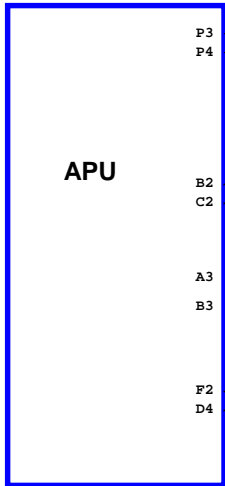
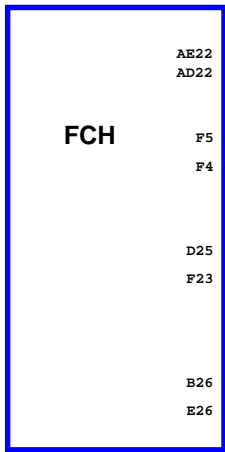

Change notes -

DATE	VERSION	DATE	Page	Modify List	OWNER
	X01	9/23	50	Delete F5001, Share Fuse with HDMI	EE
			71	DUMMY Debug Port DB1,RN7102, R7107	EE
			27	Change R2724 value to 20K, X01 Version	EE
			39,56	Change BATT1,ODD1,HDD1 Connector	ME
			27	Add C2722 0.1uF between Q2703 G&S pin for fixed leakage voltage to 3D3V_AUX_KBC under DC mode.	EE
			27	Add Q2706 2N7002 to avoid leakage loop from 3D3V_S5 to 3D3V_AUX_KBC issue when 10mW latched fail timing. Un-stuff C2713 to follow the standard schematics.	EE
			28	Change U2801, U2803 to 74.02800.A71	EE
	X01	9/29	61	Change U6102 to 74.07534.079	EE
			50	Change L5001,L5002,L5003 bead to 0402 size:68.00217.991	EE
			38,59,69,82	Change DCIN1,RJ45,TPAD1,IOBD1 Connector	ME
			82	Change IOBD1 Pin define	EE
	X01	10/13	6	Dummy APU_SIC, APU_SID level shifter, pop R644,R645	EE
			6	Add level shifter for H_Thermtrip#	EE
			36	DUMMY Q3601,R3622 for reserved	EE
			28	Change R2816,R2822 to 107KR,R2817 ,R2821to 226KR for new version P2800 chip	EE
			39	Delete R3901 for double pull high	EE
			49	Delete R4902 for double resister	EE
			27	Change PURE_HW_SHUTDOWN#(R2705) power rail to 3D3V_AUX_KBC	EE
	X01	10/20	92	Change PR9213 to 75K, PR9211 to 150K for VGA_CORE (Robson-LP)Output	Power
			27,36	Add GPIO97 for IMVP_PWRGD control ,Change D3605.2 to 1V_S0_PWRGD,Delete D3606, Change D3603.1 to VRM_VDD_PWRGD for sequence	EE
			86	Modify 1D5V_VGA_PWRGD to 1D5V_VGA_PWOK	EE
			31	Dummy R3101,R3102,Q3101,R3108 for leakage	EE
			36,47	Change R3607 to 10K,C3605 to 15n,PR4711 to 0ohm, PC4710 DY, C3610 DY, R3633 to 33K, C3615 to 33n,R3604 to33K for sequence	EE

<Core Design>

		Wistron Corporation	
		21F, 88, Sec.1, Hsin Tai Wu Rd., Hsichih, Taipei Hsien 221, Taiwan, R.O.C.	
Title			
Change notes			
Size A3	Document Number Enrico 14 AMD	Rev A00	
Date: Friday, April 22, 2011	Sheet 102 of 109		

DATE	VERSION	DATE	Page	Modify List	OWNER
	X01	10/20	20	Change R2004 to 0603 size for current tolerance	EE
			93	Change PR9311 to 10K for 1V_VGA Voltage	Power
			61,65	Add C6105,C6106,C6509,C6510 to 6.8p for solve SIV USB fail	EE
			27	Change RN2705 8P4R to 4P2R and R2715, RN2705 DY	EE
			40	Add PR4061 PR4062 100KR, empty other parts for fine tune sequence for leakage	EE
		10/27	85,17	Modify C8524,C8525=12p, C1715,C1717=18p for crystal frequency match	EE
			68	Add LED for WLAN	EE
			14	Change RN1401 to 22 ohm and pop C1423,C1424 for solved SMBus SIV Fail	EE
		11/10	38	Change DCIN CONN pin define	EE
			31	Solved leakage issue follow DV15	EE
			68	Modify Wireless LED schematic	EE
			85	Change L8502,L8503,L8507,L8505,L8513 to short pad for power	EE
			17,31	Modify C1720=15p, C3102=15p for crystal frequency match	EE
			28	Add G709 for thermal solution	EE
			68	Delete RN6802,RN6801	EE
			83-89	Change GPU from Robson LP to Seymour XT	EE
		11/17	46	DY 1V to merge 1D1V	EE
			27	Add two model ID for config	EE
			58	Delete MIC2 and move mic1 to IO Board	EE
			92	Update Seymour and Robson power plan setting (PR9219, PR9210, PR9214, PR9211)	EE
			87	Pop R8421 for check list request	EE
			68	Modify power LED schematic and charger LEDs	EE
				Merge with power schematic	Power
			27	Add LID_CLOSE# pull high	EE

<Core Design>

 Wistron Corporation 21F, 88, Sec.1, Hsin Tai Wu Rd., Hsichih, Taipei Hsien 221, Taiwan, R.O.C.		Rev
		A00
Size	Document Number	Rev
A3	Enrico 14 AMD	A00
Date:	Friday, April 22, 2011	Sheet 103 of 109

Change notes -

DATE	VERSION	DATE	Page	Modify List	OWNER
			50,51	Modift CRT,HDMI share fuse schematic	EE
	X01	11/24	31	Change L3101 to slime type and add R3101 GIGA mark for 10/100 internal PU	EE
			27	Change R2726, R2710 to F tolerance for accurate level to KBC	EE
			27,65,68	Change WLAN LED design to meet on/off behavior SPEC	EE
			27	Change RTC_POWER from RTC_AUX_S5 to 3D3V_AUX_S5 for saving RCT power and no influence on PSL	EE
			6	Pull up LTDP0_HPD to 5V from AMD SCL 1.04	EE
			6	Change RN634 to 2K2R follow AMD SCL 1.03	EE
			6	Add level shifter for LVDS SMBus follow AMD SCL 1.04	EE
			59	Rename part reference for Lan ESD	EMI
			31	Set R3101 BOM option for 8105E DY	EE
			31	Add RTC sense schematic	EE
		12/2	27	Reserved R2778 for EC power switch logic circuit.	EE
			27	Set R2769 empty, Duplicated function in page 40.	EE
			28	Reserve R2861 for hysteresis	EE
			36	Reserve C3633 for power up sequence tunning	EE
			49	Modify TP4906,TP4907 to AFTP	EE
			17,31	Change 25MHZ, 32.768K to small size by source recommand	Sourcer
			2	Modify Block Diagram	EE
			36	Change U3606 P/N	EE
			59	Modify Transformer schenatic from GIGA to 10/100 for latest config	EE
			6	Remove level shifter for LVDS SMBus(AMD confirm)	EE
			40	Reserve snuber 2.2ohm+560p for EMI solution	EMI
			50	Change L5001,L5002 and L5003 from 220hm to 30ohm for EMI Solution	EMI
			50	Change 2N7002E to 2N7002K for EOL	Sourcer

<Core Design>

		Wistron Corporation	
		21F, 88, Sec.1, Hsin Tai Wu Rd., Hsichih, Taipei Hsien 221, Taiwan, R.O.C.	
File	Change notes		
Size	Document Number	Rev	
A3	Enrico 14 AMD	A00	
Date:	Friday, April 22, 2011	Sheet	104 of 109

Change notes -

DATE	VERSION	DATE	Page	Modify List	OWNER
			27	Modify R2776 to 64.9K	EE
			59	Modify R5903,R5904 to 0603 size	EE
			27	Change R2739 to 1% tolerance	EE
			6	Change RN634 form 2.2KR to 1KR by AMD suggestion	EE
			65,68	Change WLAN LED indicator for reserve EC and module circuit	EE
			60	Change Q6001.G from +RTC_VCC to RTC_PWR	EE
			15	Reserve R1531 and R1532 69.8R for memory glitch issue	EE
			36,46	Stuff 0R and change to open-gap for merge power rail	EE
			47	Change PQ4701 to ESD 2KV for Vendor EOL	EE
			38,39	PD3801 change to P6SMBJ58A,PD3902 change to SMF18AT1G	Power
			40	Add PQ4007 PR4012 and PR4037 to improve AC_IN# delay issue	Power
			All	Change reference from PTCxx to PTxx for meet SMT Process	Power
			41,42,44,46,92	Change PC4111,PC4116,PC4117,PC4204,PC4223,PC4203,PC4301,PC4302,PC4304,PC4403,PC4404,PC4405,PC4602,PC4603,PC4604,PC4613,PC4614,PC4618,PC9202,PC9203,PC9204 to 10u 0805 size	Power
			92	PR9205 change to 13 Kohm for OCP setting	Power
			6	Remove SIC,SID level shifter	EE
	12/7		36	Reserve 1V_S0_PWRGD link for 1V_S0 power rail	EE
			38	Change PD3801: 83.P6SMB.DAG(YS) change to 83.P6SEM.DAG(CHENMKO).	Power
			86	Change U8601,U8603,U8604,U8606 pin G to 5v_S0	EE
			28	Remove R2822,R2821,C2819 and NC U2803 OTZ pin	EE
			36	Dummy C3609	EE
			49	Change R4903,R4904 to 0603 size	EE
			17	Add RTC detect pin on REQ1#_GPIO40	EE
			61,65	Move C6105,C6106,C6509,C6510 to Connector side	EE
			61	Pop TC6102 and DY on IO Board side	EE

<Core Design>

 Wistron Corporation 21F, 88, Sec.1, Hsin Tai Wu Rd., Hsichih, Taipei Hsien 221, Taiwan, R.O.C.		Rev	A00
		Size	A3
Title Change notes		Document Number	Enrico 14 AMD
Date:	Friday, April 22, 2011	Sheet	105 of 109

Change notes -

DATE	VERSION	DATE	Page	Modify List	OWNER
			71	Pop DB1,RN7102,R7107 for debug	EE
			74	DY EC7401,EC7403 for reserve	EE
			36,46	Add PC4621 and PT4603 1V_PWR and change 1V_S0 to 1V_PWR	EE
			14,59	Rename C59011 to C5901 and Change TC4101 to 79.22719.20L	EE
			46	Dummy 1V power generator foe back up solution	EE
			40	Add PR4063,PC4025 for EMI Snaber solution	EMC
		12/7_1	17	Reserve damping resistor R1766 for crystal drive level adjustment	EE
			65	Reserve BT_ACT for future module extension	EE
			69	Change KB connector	EE
		12/8	69	Add Caps led schematic and change AD_IA_HW2 to GPIO50, PCIE_RST# to GPIO36, CAP_LED change to GPIO30	EE
		12/10	27	Add R2780 and DY R2732,Q2702 for EC "PROCHOT_EC" pin from PP to OD type	EE
		12/13	68,82	Change IOBD2 and PWBTN1 pin define	EE
			38,40,41	PC3806 PC4006 PC4008 PC4110 and PC4114 change to 10uF 25V 0805 size (78.10622.51L)	Power
			28	Change U2801,U2803 to B version(74.02800.B71)	EE
			97	Add EMI Solution	EMI
		12/14	40	Change PC4004 and PC4024 from 1uF to 0.1uF (78.10424.2BL)	Power
			28	DY R2816,R2817,C2831 for set ADJ floating	EE
			61	DY TC6102 for reserve on IO board	EE
		12/15	82	Change IOBD2 pin define and connector	EE, ME
			20	Chnage R2004 to 0402 size	EE
			17	Change R1766 location and change to 1KR for Put Rd at chip output side and suppress amplitude.	EE
		12/17	6,65	Swap RN605,TR6501 for Layout	EE
			97	Add EMI Solution	EMI
			36	Change C3615 tolerance from 16V to 25V for component derating high voltage tolerance	EE

<Core Design>

 Wistron Corporation 21F, 88, Sec.1, Hsin Tai Wu Rd., Hsichih, Taipei Hsien 221, Taiwan, R.O.C.		Title	
		Change notes	
Size	Document Number	Rev	
A3	Enrico 14 AMD	A00	
Date: Friday, April 22, 2011		Sheet	106 of 109

Change notes -

DATE	VERSION	DATE	Page	Modify List	OWNER
			36	Delete R2779 for LID_Close# double pull high	EE
		12/21	59	Change C5904 to 0.01u from vendor recommend	EE
			50	Modify CRT Hsync & Vsync level shift follow DV15	EE
			46	Modify 1V_S0 Schematic	EE
		12/21_1	42	DY PR4214,PR4402 for pull up on R3624	EE
		12/22	61	DY C6104,C6108	EE
		12/22_1	56	Change HDD1 CONN to 62.10065.H71	ME
			61	DY TC6101, Stuff TC6103	EE
		12/23	20	Change to 10u 0805 size	EE
		12/23_1		Implement OPI Solution	EE
		12/27		Crooeect VGA setting, PR9210:150K, PR9211:75K	EE
X02		03/03	41	Change PR4104 to 0 ohm,PR4106 to 200K	EE
			83	DY R8309,R8310 to solve device error	EE
			31	Move C3125 to Q3101.S ,R3134 to 100k to solve unnecessary pulse	EE
				Change C3102,C3103 to 18P from vendor recommend	EE
			17	Change RN1701 to 22 ohm for solve SIV solution	EE
			50	Change RN5001 to 150 ohm for solve SIV solution	EE
				Stuff C5002,C5003,C5004	EE
			97	Add SPR3,SPR4	ME
			59	Add RN5901 for nonuse Giga lan	EE
			50,59,97	Change CRT ,TPAD1,RJ45 CONN, H10 Hole and add SPR3,SPR4	ME
		03/07	83~87	Change VGA P/N to 71.ROBSO.M01	EE
			85	DY R8525,R8526 and Q8501 for nonuse	EE
			28	DY R2813,R2805,R2832,C2808,U2805,R2812,R2811, Stuff R2823 for P2800	EE

<Core Design>



file	Change notes	
Size	Document Number	Rev
A3	Enrico 14 AMD	A00
Date:	Friday, April 22, 2011	Sheet 107 of 109

Change notes -

VERSON	DATE	Page	Modify List	OWNER
		28,85	DY U2803,R2815,R2812,R2814,C2813,C2814. stuff RN8501,Q8503 for GPU temperature by SMBus	EE
	03/09	27	DY D2701,D2704 and D2705, Add R2781,R2782 and R2783 for connect directly	EE
		97	Change SPR3 to 34.39S07.003	EE
		38,39	Rename AFPP3811,3812,3813,3814,3901,3902,3903,3904 to AFTP	EE
	03/10	38,60	Delete AFTP6001,AFTP6002,AFTP3811	EE
		17	Change C1719,C1720 to 18p for vendor recommand	EE
		40	Delete PR4063 and PC4025 for EMI Solution	EE
	03/10_1	71	Add R7102 to reserved	EE
		27	Change R2724 to 33k for SC PCB version	EE
		31	Add RN3101,Q3104 and R3108 to solve Lan leakage issue	EE
	03/11	41,42,47	Change power gap P/N	EE
			Change 0 ohm to short pad	EE
		61,65,82	Delete TR6101,TR6501,TR8202,TR8201 CMC	EE
	03/16	41	Change PR4103 from 150Kohm to 143Kohm for 5V OCP setting	Power
		44	Change PR4408 from 75Kohm to 66.5Kohm for 1.5V OCP setting	Power
		92	Change PR9205 from 13Kohm to 11 Kohm for VGA OCP setting	Power
		47	Change PC4709 from 1.5KpF to 100pF for comp	Power
		46	Dummy PC4602 and POP PC4604.	Power
	03/17	28	DY C2818,D2802,C2816 and Stuff C2815	EE
	03/22	40	DY PQ4007,PR4037,PR4012 for new version IC	EE
A00	04/07	49	Add 0 ohm at Q4901.4 for reserved to avoid module leakage	EE
		71	Change DB1 foorprint to PAD-10P-177042 for factory request	EE
		18	Change R1818 to 0 ohm for reserved non-zero power ODD	EE
	04/11	18	Change R2724 to 47K for X-build version	EE

<Core Design>



Dell Wistron Corporation
21F, 88, Sec.1, Hsin Tai Wu Rd., Hsichih,
Taipei Hsien 221, Taiwan, R.O.C.

File		Change notes	
Size	Document Number	Rev	
A3	Enrico 14 AMD	A00	
Date:	Friday, April 22, 2011	Sheet	108 of 109

Change notes -

VERSON	DATE	Page	Modify List	OWNER
	4/12	40	DY PR4029,PR4028,PQ4004 and PQ4006 for nouse because just use 65W adapter	EE
		40	Change C8617 to 10u for CRB to avoid voltage drop	EE
		20	DY C2005,C2007, and add R2030 for nonuse	EE
		97	Change H12,H13 to 34.4HLL17.001 for ME asked	ME
	4/12_1	97	Delete H13 for ME asked	ME
		18	Change EC1801 to 22p for EMI solution	EMC
	4/13	68	Change R6806,R6812,R6801,R6833 to 330 ohm for brightness	EE
	4/15	56	DY R5612, Pop Q5602 for modify Zero power ODD	EE
		51	Chnage RN5004 to ZZ.0R08P.ZHH to modify layout symbol is short pad	EE
	4/17	28	Change R2817 to 0 ohm for setting T8 temperature from 85 to 90 degree to pass reliability test	EE
	4/21	56	DY U5601,TC5604,R5606,Q5601,R1818,R5612, Stuff R5604,R5603 for remove Zero power ODD	EE

Core Design>

DELL Wistron Corporation
21F, 88, Sec.1, Hsin Tai Wu Rd., Hsichih,
Taipei Hsien 221, Taiwan, R.O.C.

file Change notes

Size A3	Document Number Enrico 14 AMD	Rev A00
------------	----------------------------------	------------

Date: Friday, April 22, 2011 Sheet 109 of 109