

# AZEDA-INTEGRATED

PWA: K3885, SCHEM: J3964  
VER : 3A

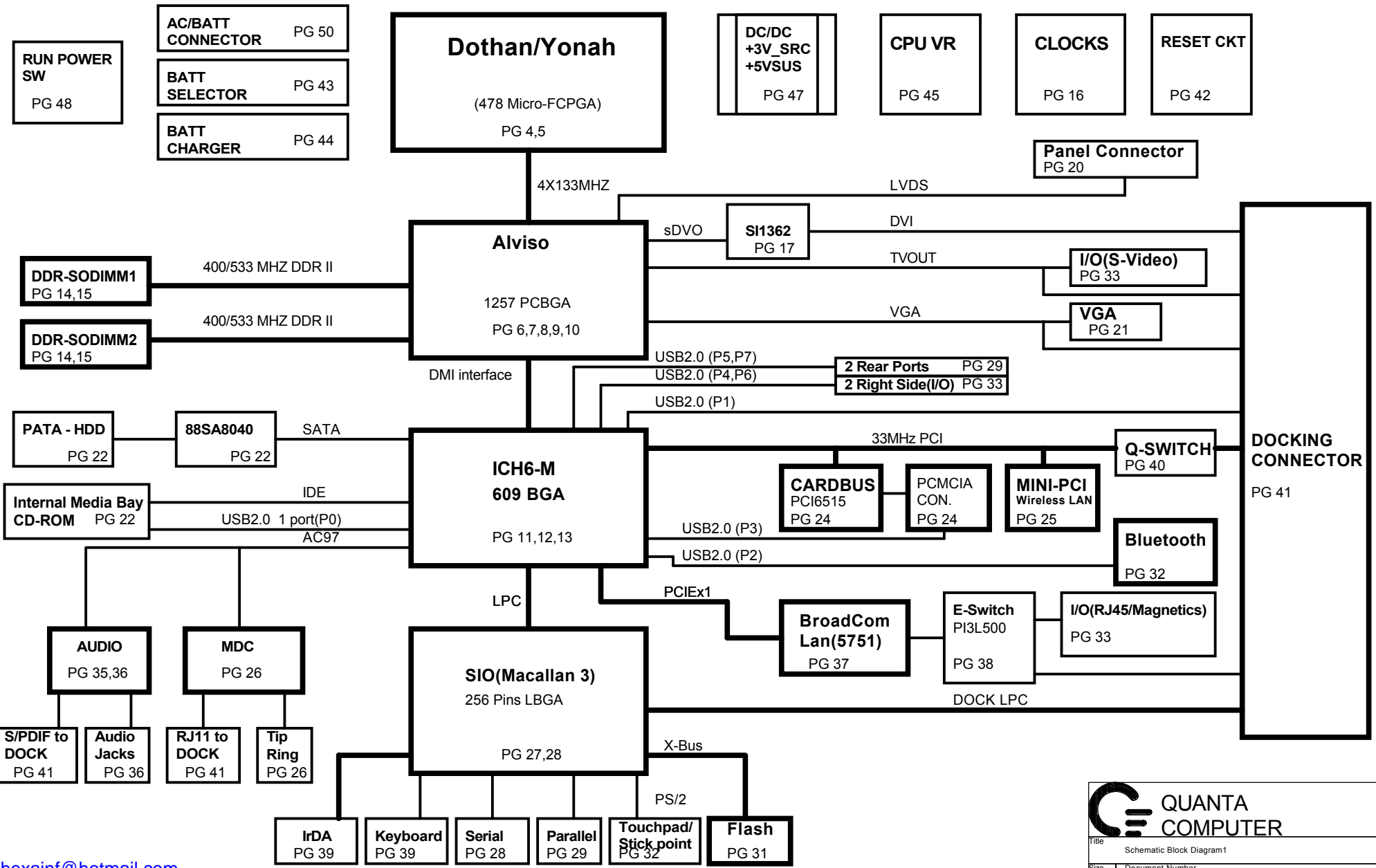

hexainf@hotmail.com  
GRATIS - FOR FREE

**QUANTA COMPUTER**

Title: Schematic Block Diagram1

Size	Document Number JM5B	Rev 1A
Date: 星期五, 十月 29, 2004	Sheet 1	of 50

Blank Page



Title		
Size	Document Number	Rev
	JMSB	1A
Date:	星期五, 十月 29, 2004	Sheet 2 of 50

INDEX

Pg#	Description	DNI LIST
1	Schematic Block Diagram 1	
2	Blank Page	
3	Front Page	
4-5	Dothan	
6-10	Alviso	
11-13	ICH6	
14-15	DDRII SO-DIMM(200P)	
16	Clock Generator	
17	CH7306/7	
18-19	Blank Pages	
20	LCD Conn. & SSP	
21	CRT & TV Conn.	
22	SATA & IDE Conn.	
23	Screw Hole	
24	TI PIC6515	
25	Mini PCI Conn.	
26	MDC Conn.	
27-28	SIO (LPC47N354)	
29	SERIAL PORT & USB	
30	PARALLEL CONN.	
31	Flash ROM	
32	TOUCH PAD & BLUE TOOTH	
33	Switch Board Conn. & LED	
34	FAN & Thermal	
35-36	Audio CODEC (STAC9751) & Phone Jack	
37-38	LOM (BCM5751), Switch	
39	FIR	
40-41	Docking Conn. & Q-Switch	
42	Power Good	
43-44	Battery Selector & Charger	
45	CPU Power	
46	1.8V,0.9V,1.5V,1.05V	
47	3VALW/5V/3V/Power ON	
48	RUN Power Switch	
49	VGA DC/DC	
50	DCIN/Batt Conn.	

Power & Ground

Label	Pg#	Description	Control Signal
DC_IN+		AC ADAPTER (20V)	
PBATT+		MAIN BATTERY + (10~17V)	
PWR_SRC		MAIN POWER (10~20V)	
RTC_PWR3_3V		RTC & PCL POWER (3_3V)	
+12V		+12V	DRUNPWROK
VHCORE		CPU CORE POWER (1.25/1.15V)	RUNPWROK
V1_2RUN		AGTL+ POWER (1.2V)	RUNPWROK
+3VRUN		SLP_S3# CTRLD POWER	RUN_ON
+3VSUS		SLP_S5# CTRLD POWER	SUS_ON
+5VALW		8051 POWER (5V)	
+5VRUN		SLP_S3# CTRLD POWER	RUN_ON
+5VSUS		SLP_S5# CTRLD POWER	SUS_ON
+5VHDD		HDD POWER (5V)	HDDC_EN#
+5VMOD		MODULE POWER (5V)	MODC_EN#
STRB#5V		EXTERNAL FDD POWER (5V)	FDD/LPT#
+5VFAN1, +5VFAN2		FAN POWER (5V)	FAN_OFF/ON#
VDDA		AUDIO ANALOG POWER (5V)	RUN_ON
1_8VSUS		RESUME WELL IN ICH	
1_8VRUN		SLP_S3# CTRLD POWER	
+3VALW		8051 POWER (3V)	
V1_5RUN		AGP I/O POWER	
 GND	ALL PAGES	DIGITAL GROUND	
 GNDP		CPU POWER GND	
 CGNDP		CHARGER GND	
 DGNDP		DC/DC POWER GND	
 LANGND		COMBO CONN GND	



Title Index, DNI, Power & Ground		
Size	Document Number JMSB	Rev 1A
Date: 星期五, 十月 29, 2004	Sheet 3	of 50

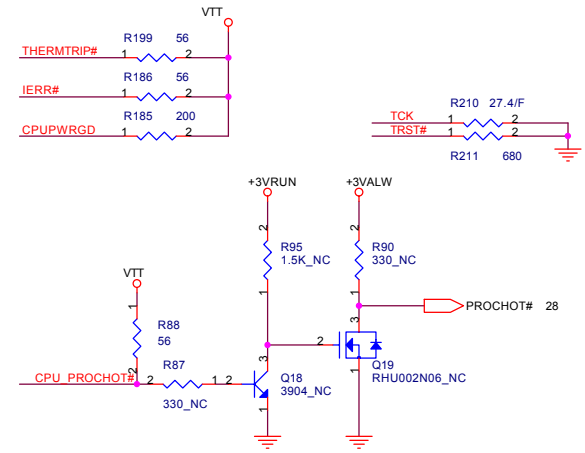
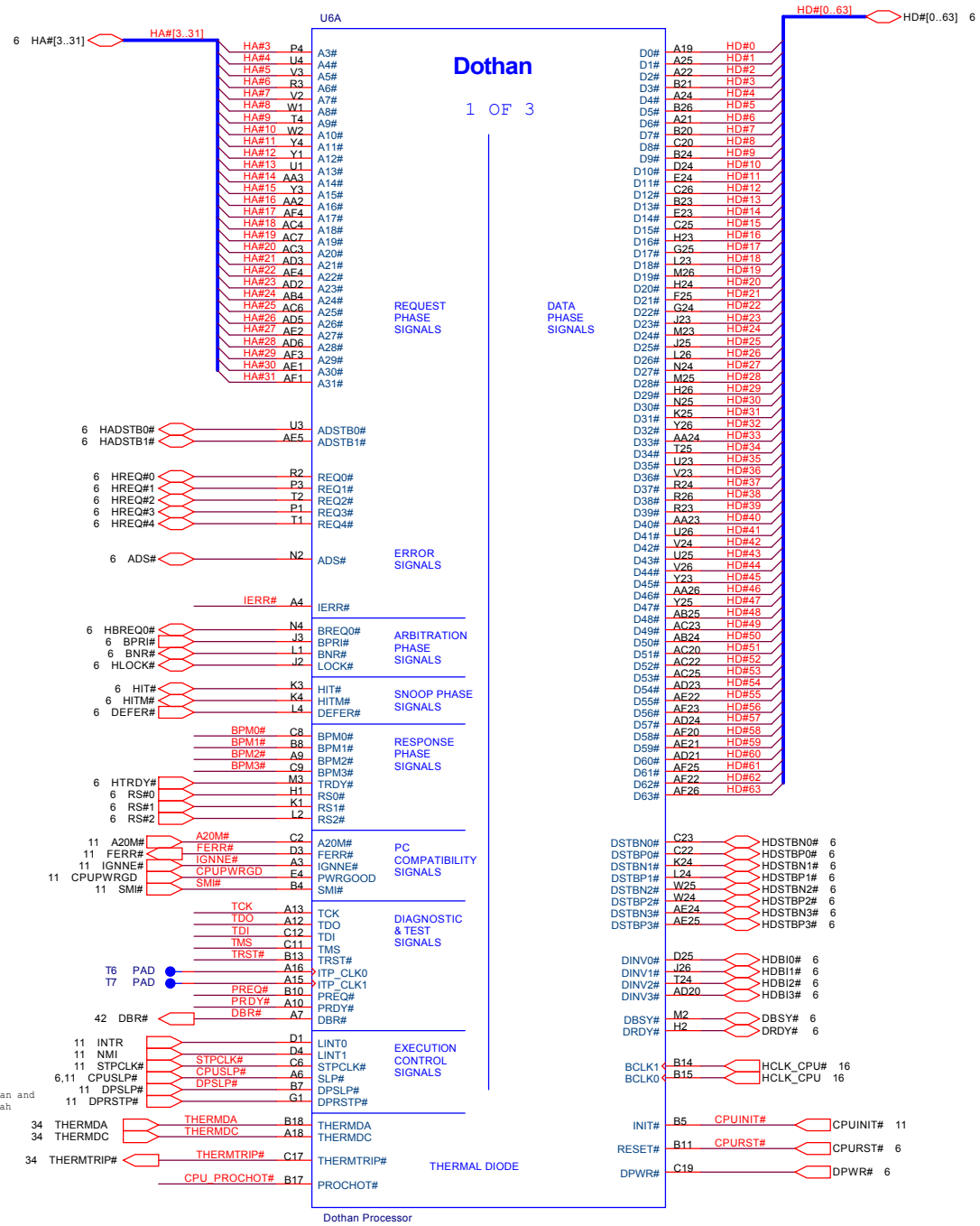

Signal	Resistor Value	Connect To	Resistor Placement
TDI	150 ohm +/- 5%	VTT	Within 2.0" of the CPU
TMS	39 ohm +/- 5%	VTT	Within 2.0" of the CPU
TRST#	680 ohm +/- 5%	GND	Within 2.0" of the CPU
TCK	27 ohm +/- 5%	GND	Within 2.0" of the CPU
TDO	Open	VTT	Within 2.0" of the CPU
ITP_EN	R268 Depop	+3VRUN	Close to CR410M Pins

Note: Populate R214, R216, C366, and R268 when ITP connector is populated.

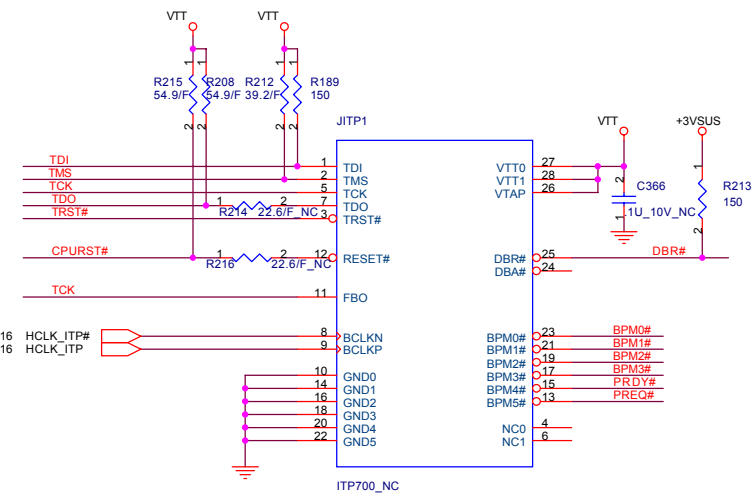

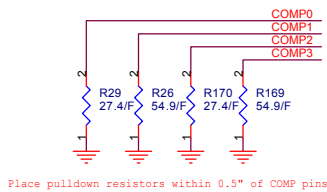

Place pulldown resistors within 0.5" of COMP pins

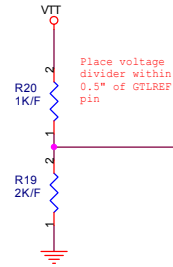

- COMP0 P25
- COMP1 P26
- COMP2 AB2
- COMP3 AB1

GTLREF0 AD26

- TEST1 C5
- TEST2 F23
- NC1
- RSVD2 C3
- RSVD3 AF7
- RSVD4 AC1
- RSVD5 E26

**Dothan**  
2 OF 3

POWER, GROUND, RESERVED SIGNALS

- VCCA3 AC26
- VCCA2 N1
- VCCA1 B1
- VCCA0 F26

CPU\_VCCA

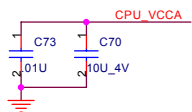

VHCORE

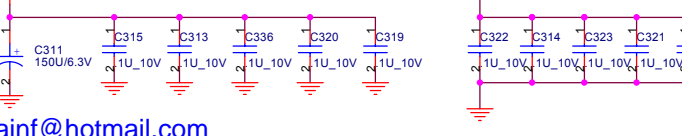
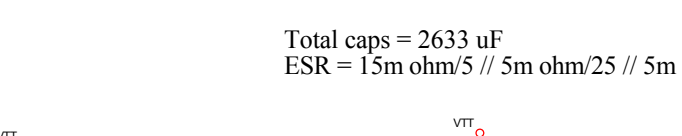
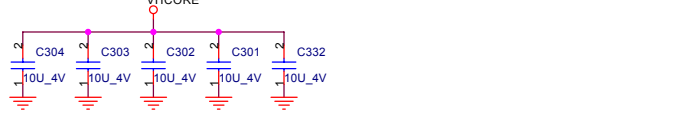
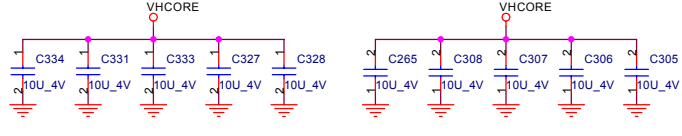
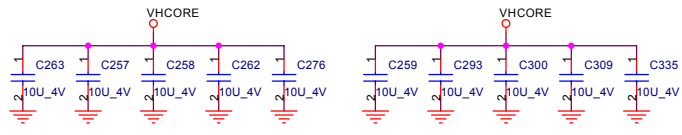
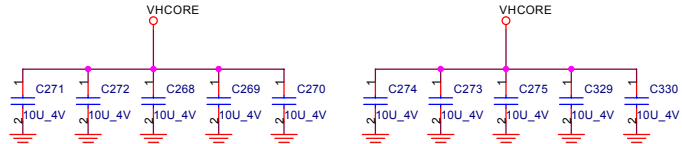

Total caps = 2633 uF  
ESR = 15m ohm/5 // 5m ohm/25 // 5m ohm/15

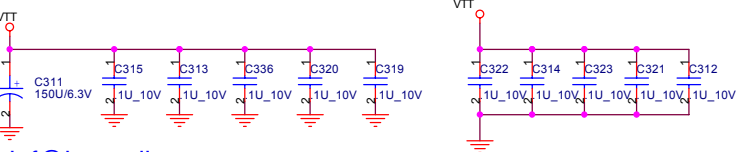

hexainf@hotmail.com  
GRATIS - FOR FREE

U6B	COMP0 P25	VSS00 A2
	COMP1 P26	VSS01 A5
	COMP2 AB2	VSS02 A8
	COMP3 AB1	VSS03 A11
		VSS04 A14
		VSS05 A17
		VSS06 A20
		VSS07 A23
		VSS08 A26
		VSS09 B3
		VSS10 B6
		VSS11 B9
		VSS12 B12
		VSS13 B16
		VSS14 B19
		VSS15 B22
		VSS16 B25
		VSS17 C1
		VSS18 C4
		VSS19 C7
		VSS20 C10
		VSS21 C13
		VSS22 C15
		VSS23 C18
		VSS24 C21
		VSS25 C24
		VSS26 D2
		VSS27 D5
		VSS28 D7
		VSS29 D9
		VSS30 D11
		VSS31 D13
		VSS32 D15
		VSS33 D17
		VSS34 D19
		VSS35 D21
		VSS36 D23
		VSS37 D26
		VSS38 D29
		VSS39 D32
		VSS40 D35
		VSS41 D38
		VSS42 D41
		VSS43 D44
		VSS44 D47
		VSS45 D50
		VSS46 D53
		VSS47 D56
		VSS48 D59
		VSS49 D62
		VSS50 D65
		VSS51 D68
		VSS52 D71
		VSS53 D74
		VSS54 D77
		VSS55 D80
		VSS56 D83
		VSS57 D86
		VSS58 D89
		VSS59 D92
		VSS60 D95
		VSS61 D98
		VSS62 D101
		VSS63 D104
		VSS64 D107
		VSS65 D110
		VSS66 D113
		VSS67 D116
		VSS68 D119
		VSS69 D122
		VSS70 D125
		VSS71 D128
		VSS72 D131
		VSS73 D134
		VSS74 D137
		VSS75 D140
		VSS76 D143
		VSS77 D146
		VSS78 D149
		VSS79 D152
		VSS80 D155
		VSS81 D158
		VSS82 D161
		VSS83 D164
		VSS84 D167
		VSS85 D170
		VSS86 D173
		VSS87 D176
		VSS88 D179
		VSS89 D182
		VSS90 D185
		VSS91 D188
		VSS92 D191
		VSS93 D194
		VSS94 D197
		VSS95 D200
		VSS96 D203
		VSS97 D206
		VSS98 D209
		VSS99 D212

Dothan Processor

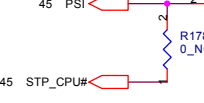
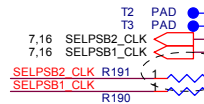
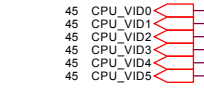
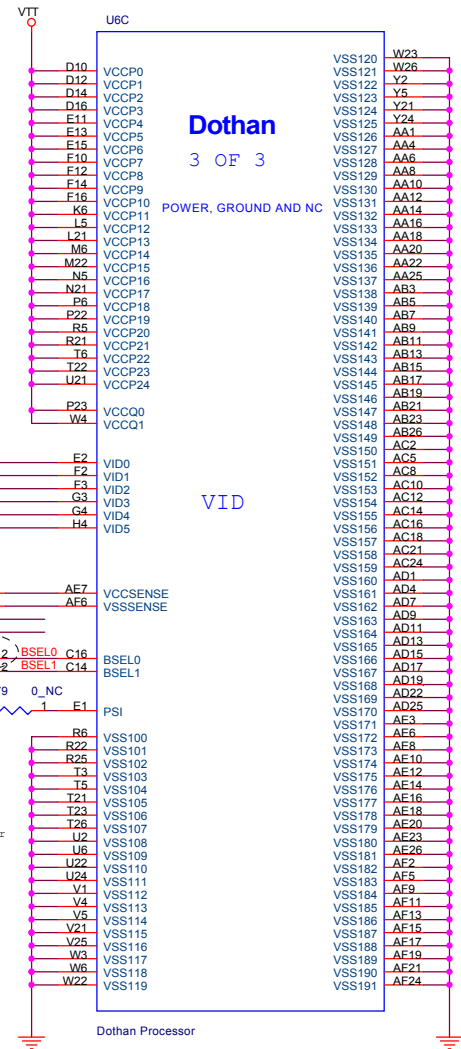

Do not install R191 for Dothan-A and install for Dothan-B



Title		
Dothan Processor (POWER)		
Size	Document Number JMSB	Rev 2A
Date:	星期五, 十月 29, 2004	Sheet 5 of 50

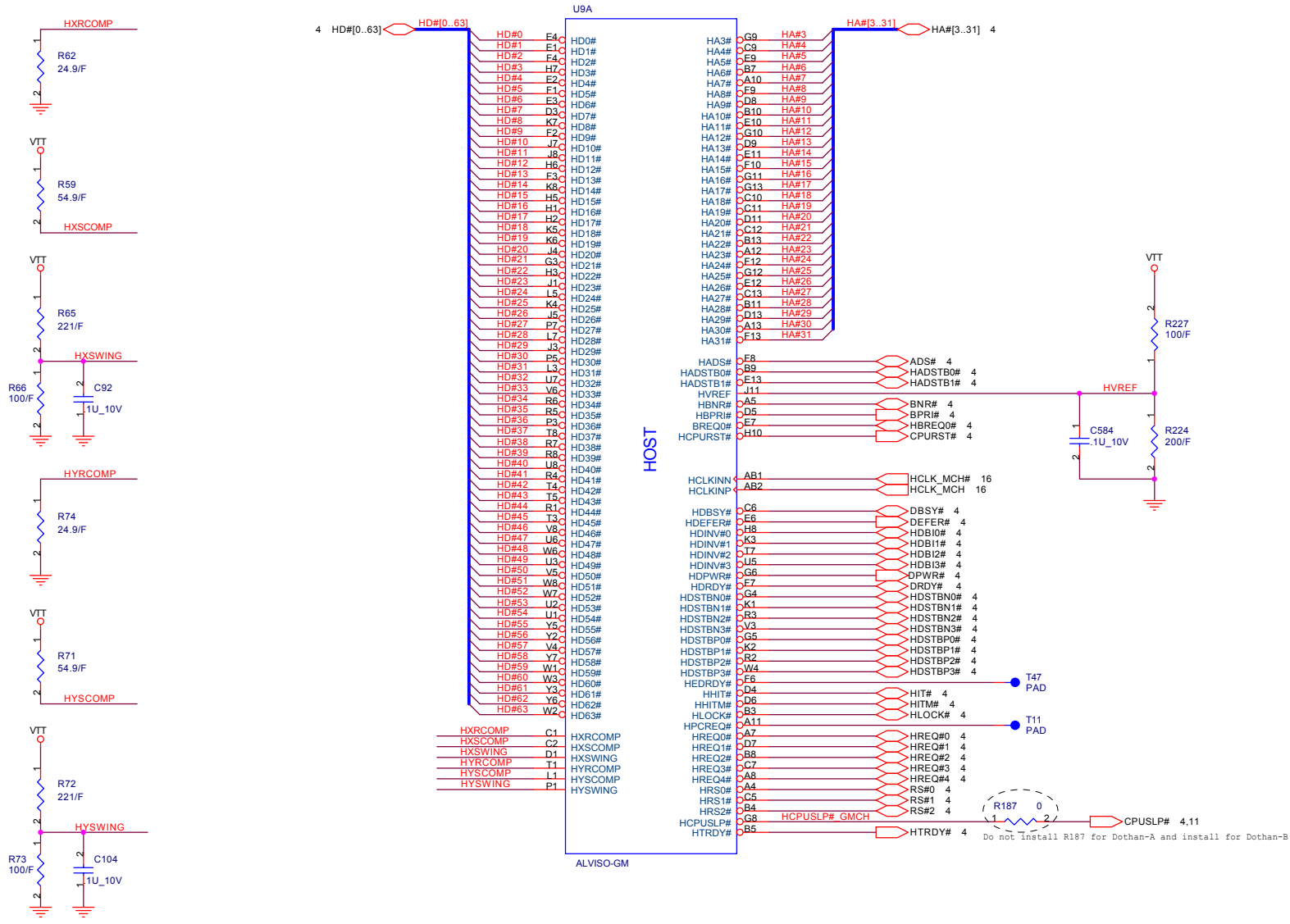

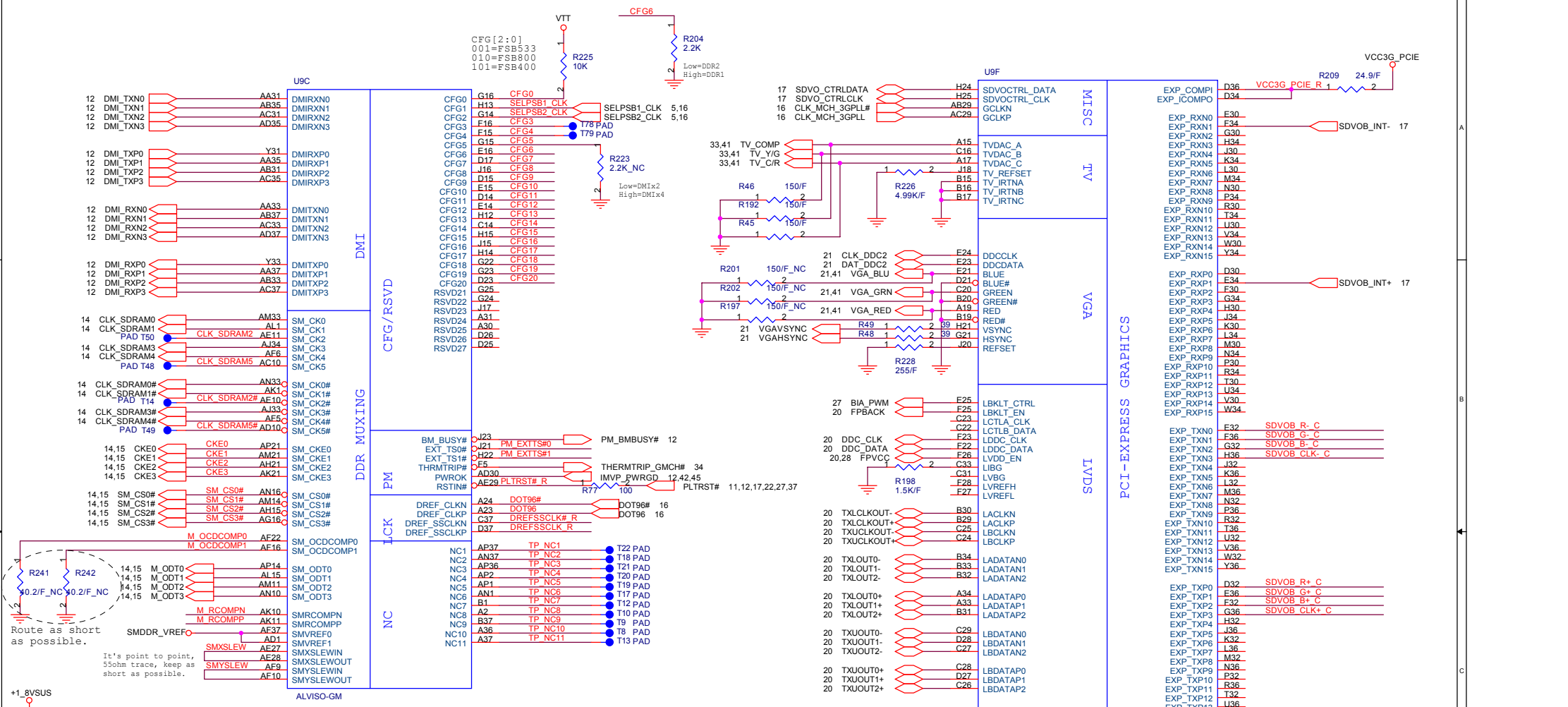

Route as short as possible.

It's point to point, 55ohm trace, keep as short as possible.

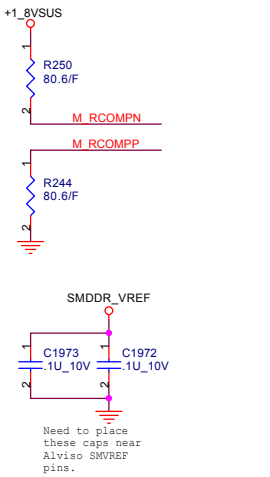

DREFSSCLK support: Populate RP26 if using CK-SSCD. Populate RP27 if using CK410

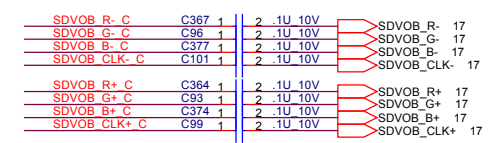

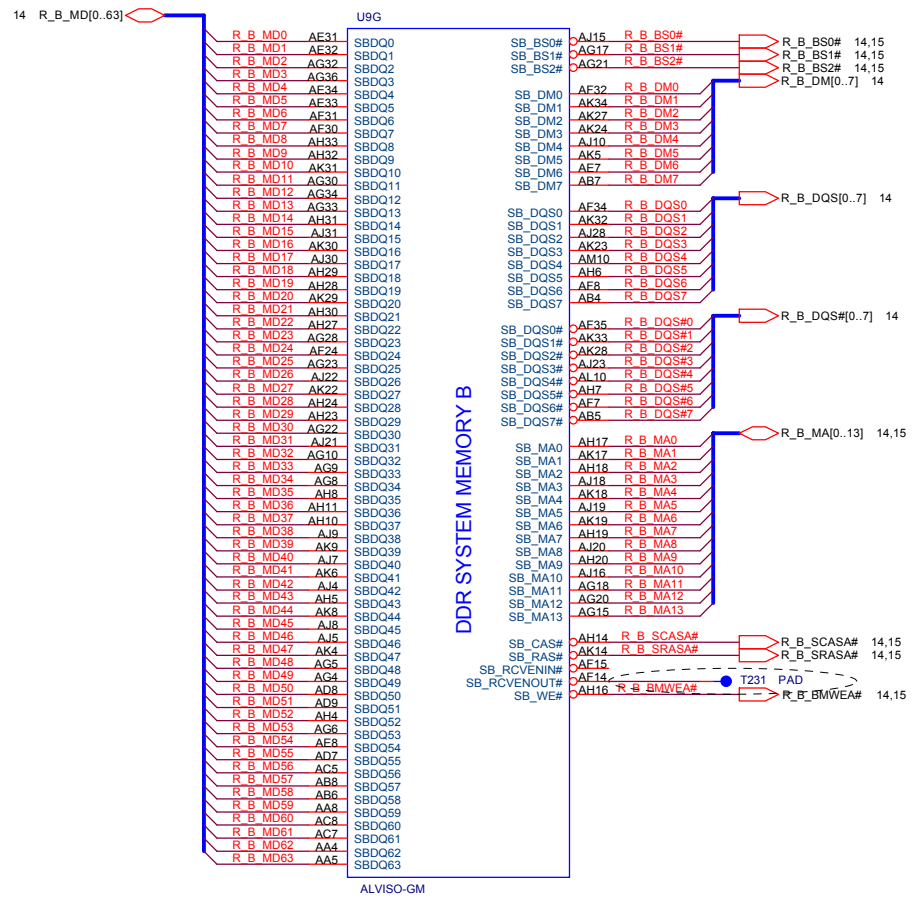
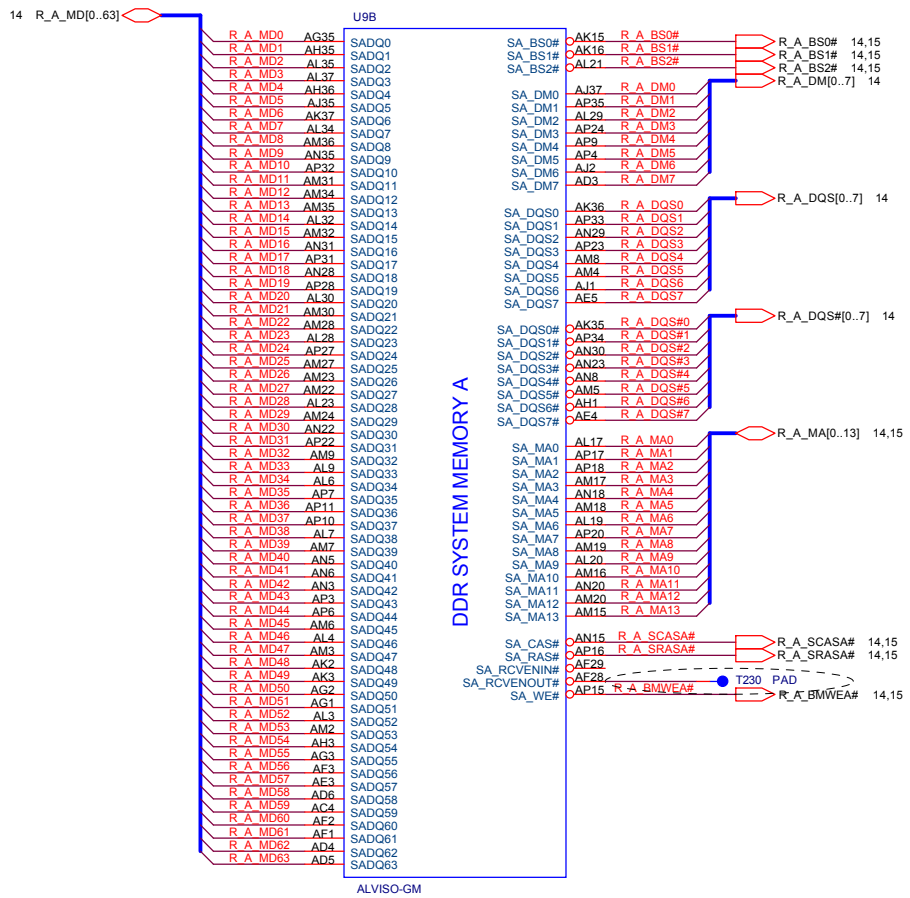



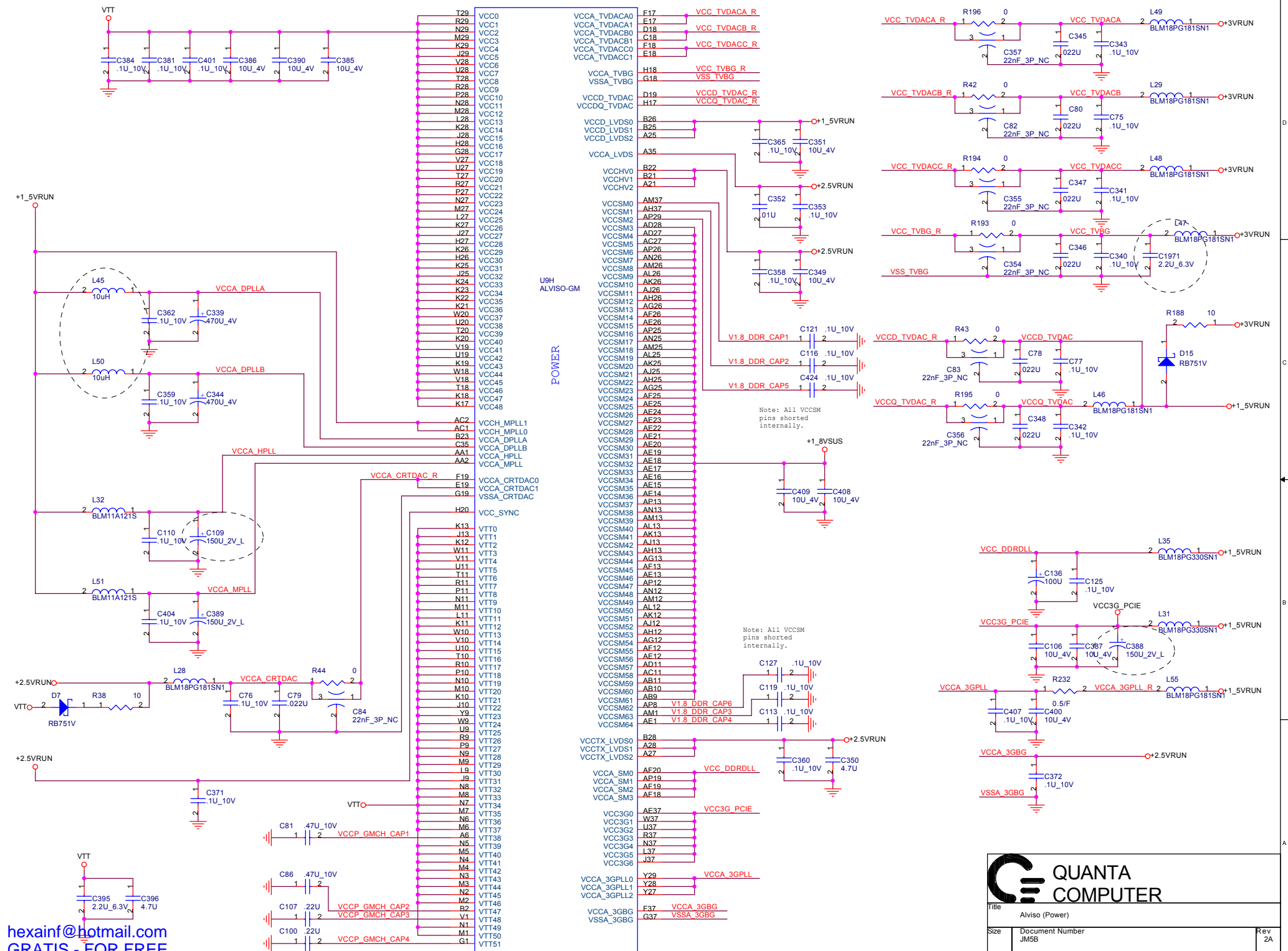

hexainf@hotmail.com  
GRATIS - FOR FREE

**QUANTA  
COMPUTER**

Title Alviso (Power)		
Size	Document Number JMSB	Rev 2A
Date:	星期三, 十月 29, 2004	Sheet 9 of 50

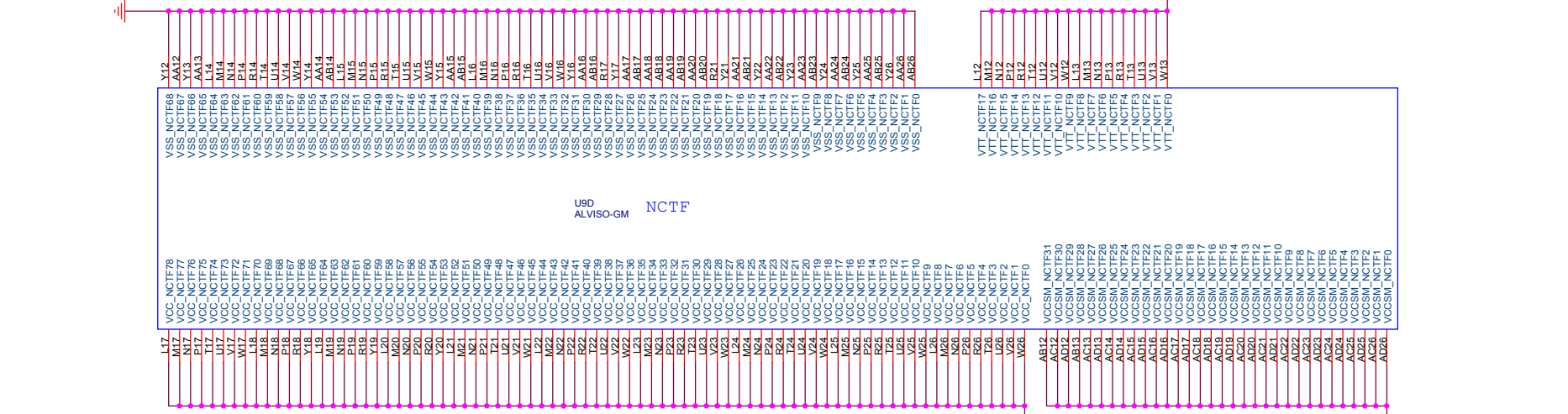
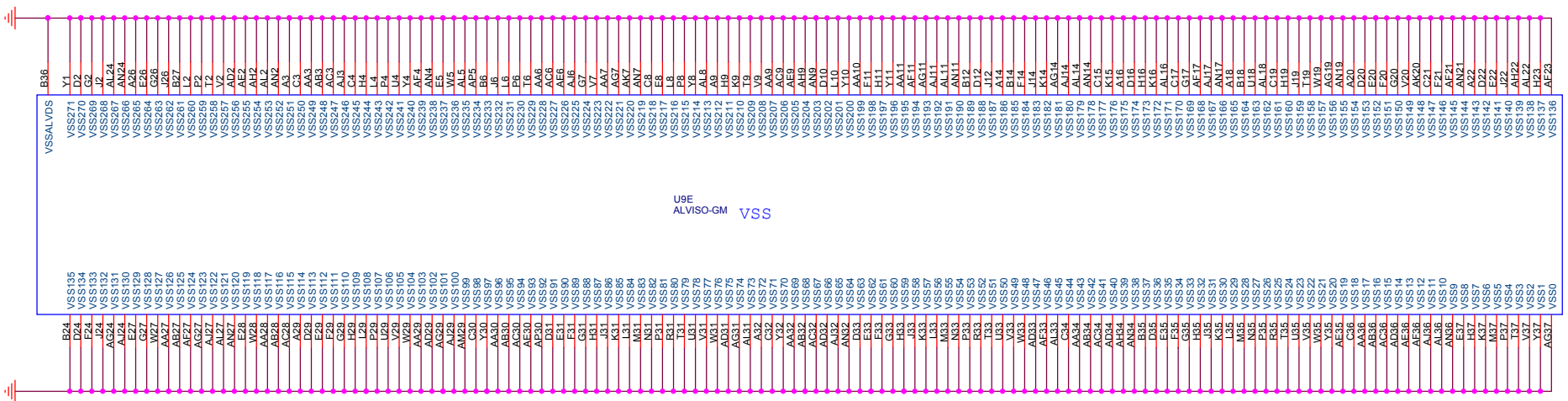

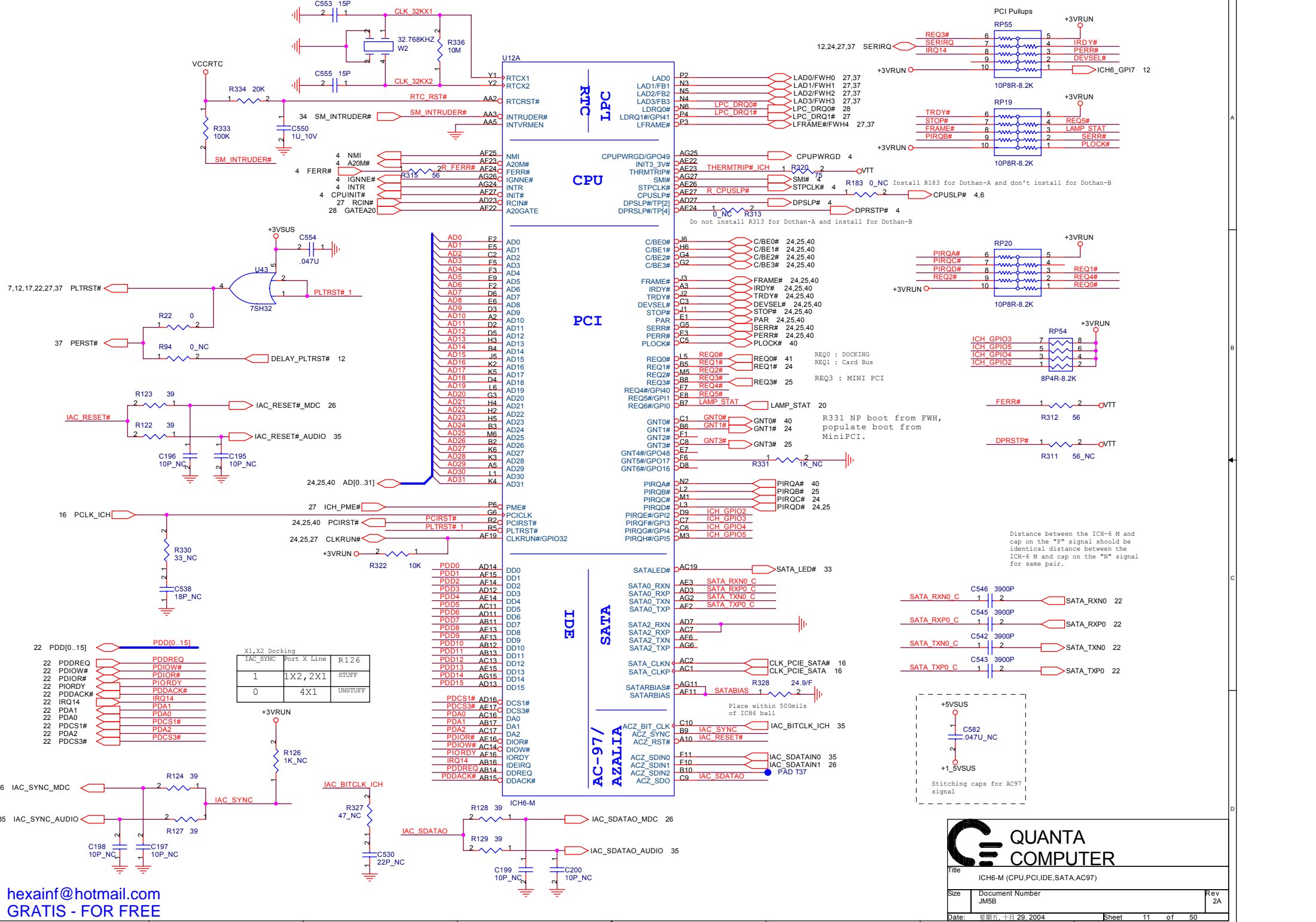

hexainf@hotmail.com  
GRATIS - FOR FREE



Title ICH6-M (CPU,PCI,IDE,SATA,AC97)		
Size	Document Number JMSB	Rev 2A
Date	星期五, 十月 29, 2004	Sheet 11 of 50



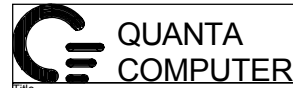
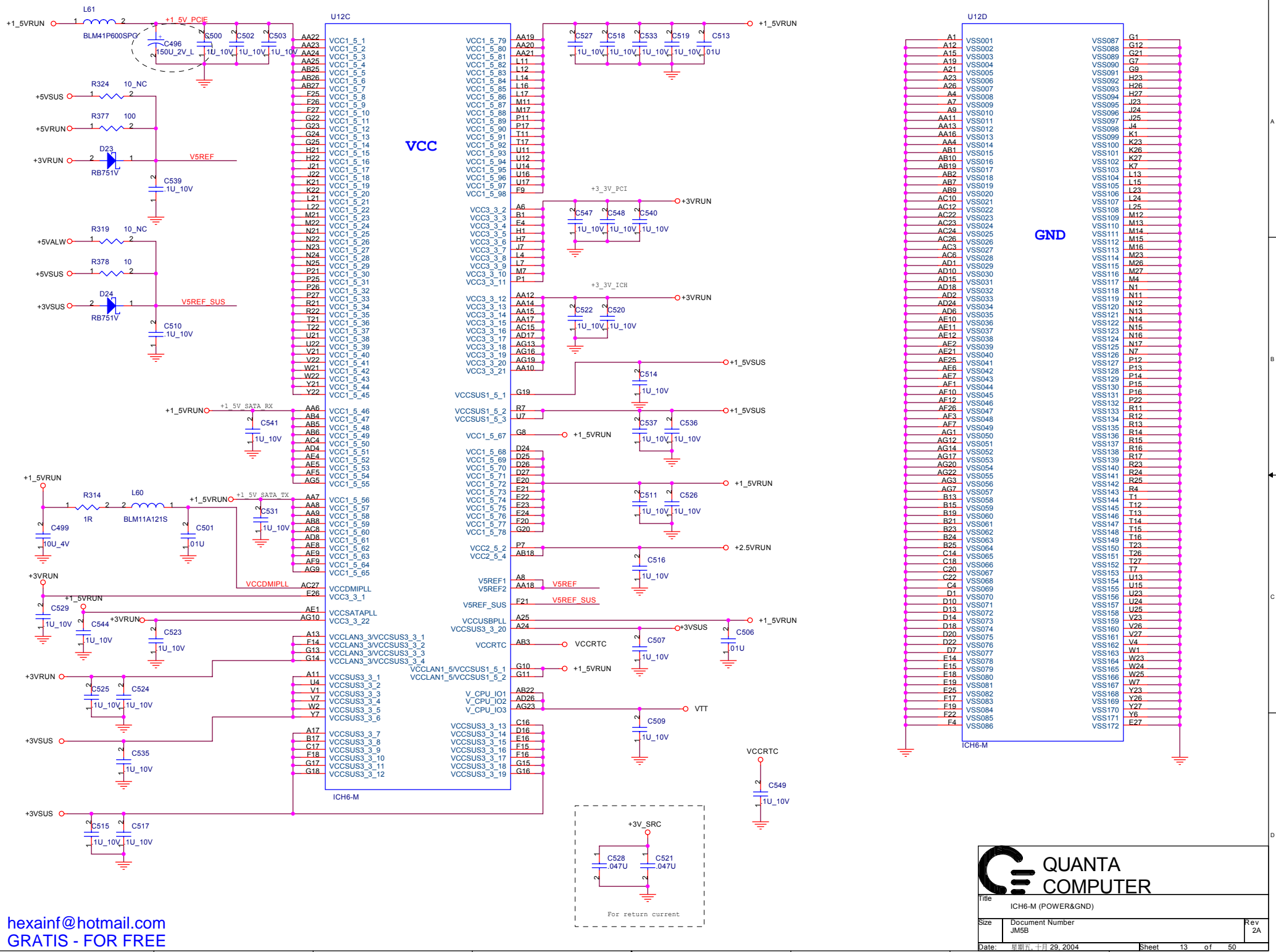

Title ICH6-M (POWER&GND)		
Size	Document Number JMSB	Rev 2A
Date:	星期五, 十月 29, 2004	Sheet 13 of 50

hexainf@hotmail.com  
GRATIS - FOR FREE

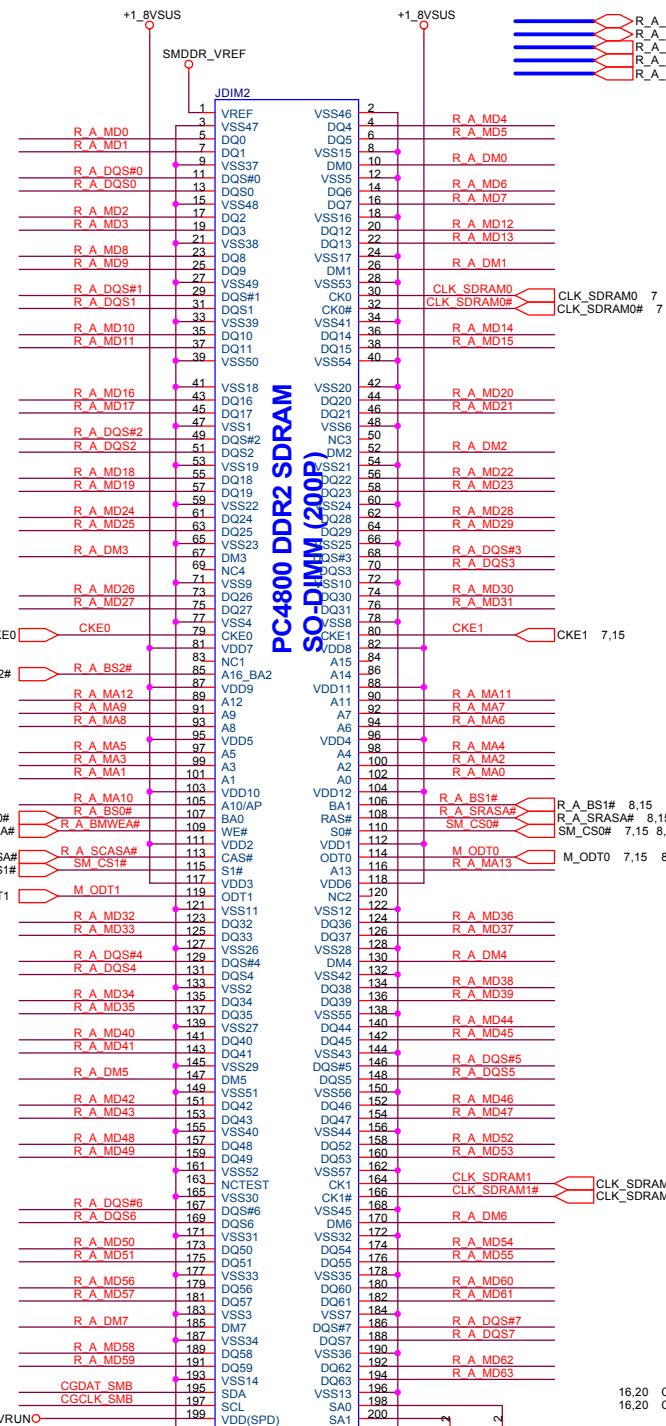

**PC4800 DDR2 SDRAM  
SO-DIMM (200P)**

**CLOCK 0,1,2  
CKE 0,1**

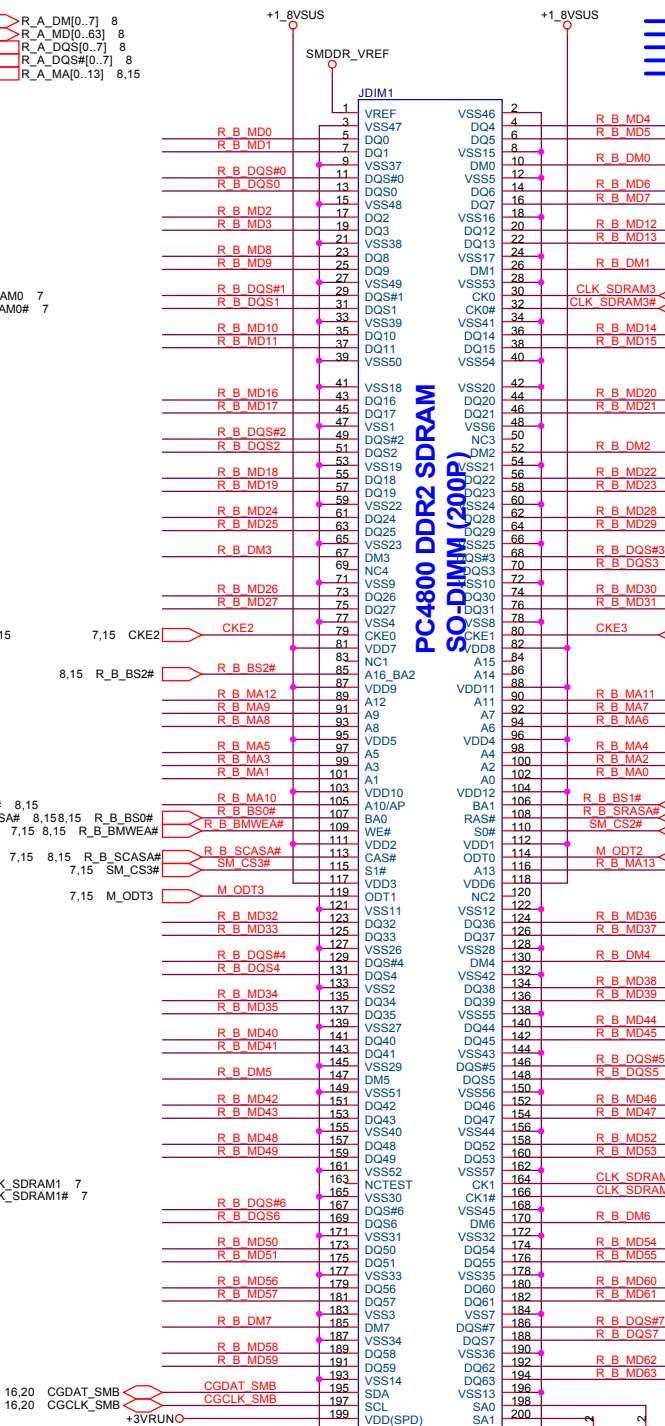

**PC4800 DDR2 SDRAM  
SO-DIMM (200P)**

**CLOCK 3,4,5  
CKE 2,3**

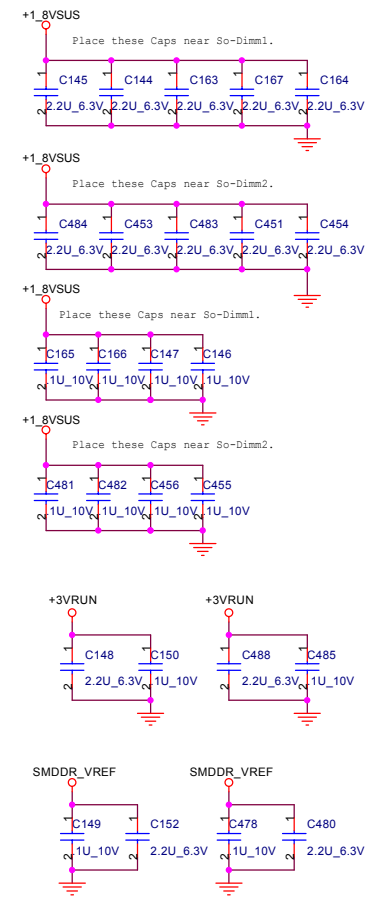

R\_A\_MA[0..13] 8,14

R\_B\_MA[0..13] 8,14

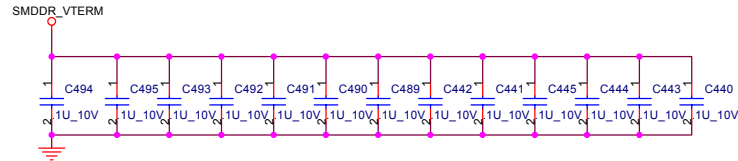

Layout note: Place 1 cap close to every 1 R-pack terminated to SMDDR\_VTERM.

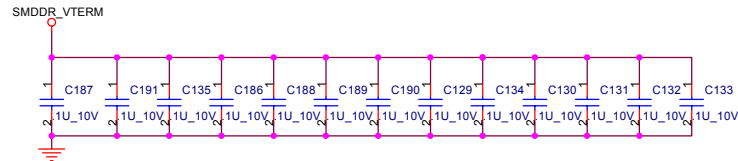

Layout note: Place 1 cap close to every 1 R-pack terminated to SMDDR\_VTERM.

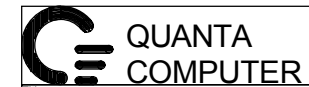
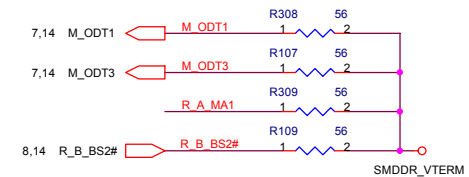
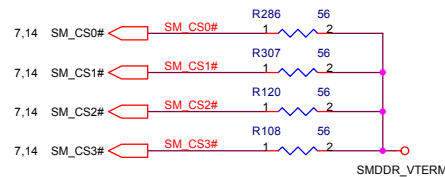
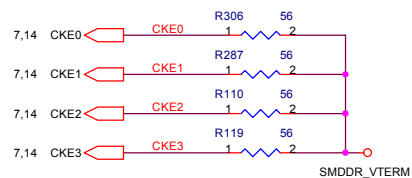
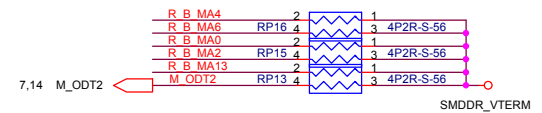
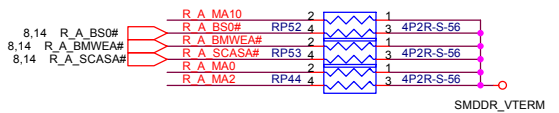
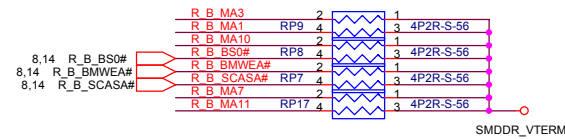
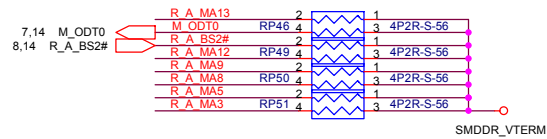
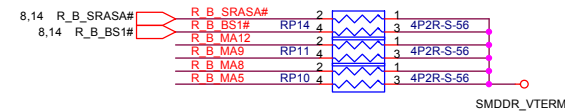
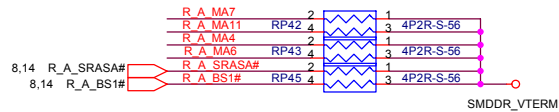

Title DDR RES.ARRAY		
Size	Document Number JMSB	Rev 2A
Date:	星期五, 十月 29, 2004	Sheet 15 of 50

FSC	FSB	FSA	CPU	SRC	PCI
1	0	1	100	100	33
0	0	1	133	100	33
0	1	1	166	100	33
0	1	0	200	100	33
0	0	0	266	100	33
1	0	0	333	100	33
1	1	0	400	100	33
1	1	1	RSVD	100	33

Place these termination to close CK410M.

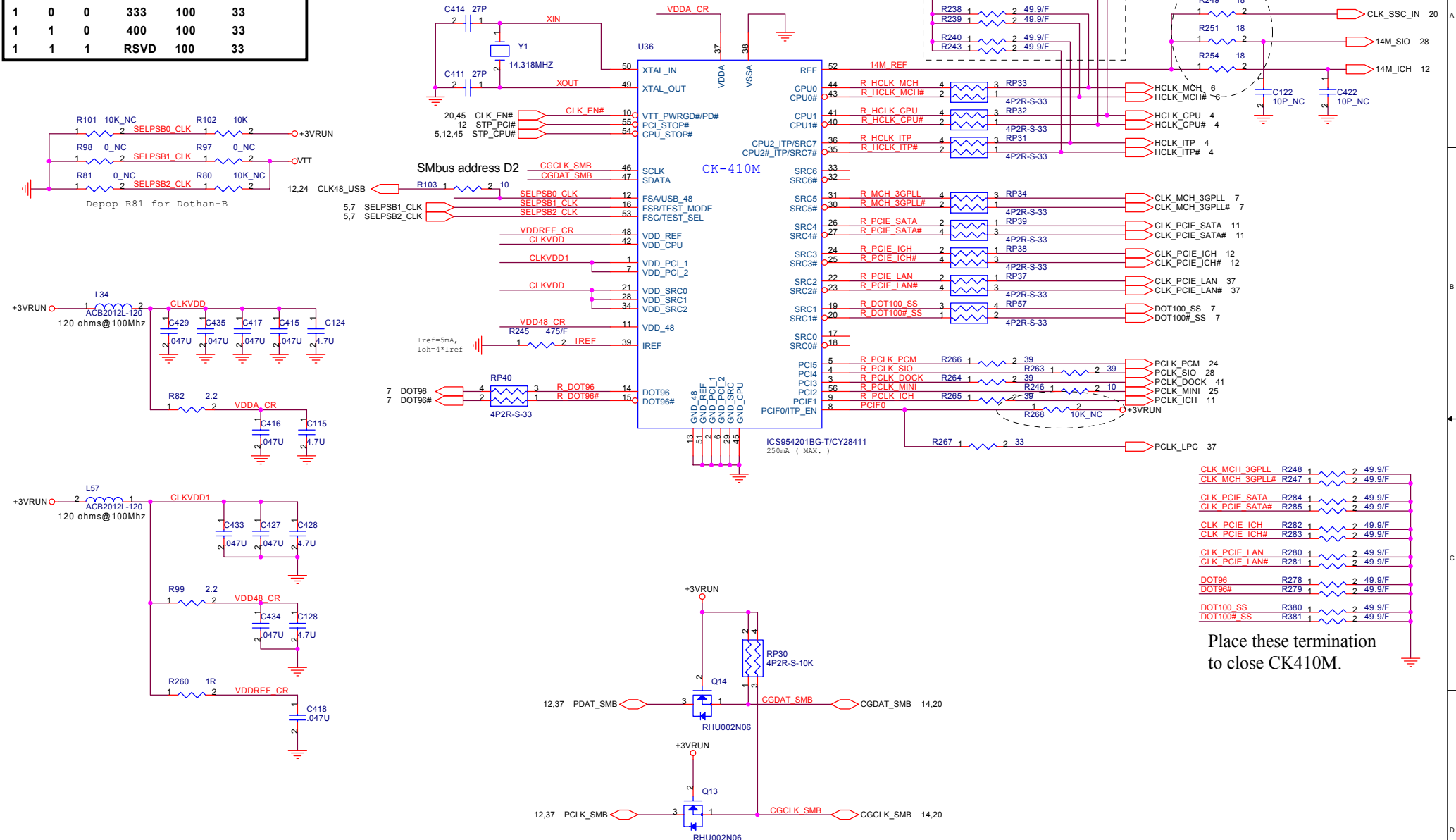

Place these termination to close CK410M.

These are for backdrive issue

**QUANTA COMPUTER**

Title: CLOCK GENERATOR

Size: Document Number: JMSB Rev 2A

Date: 星期五, 十月 29, 2004 Sheet 16 of 50



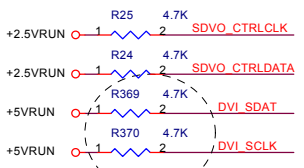

Placed this capacitor close to OVCC.

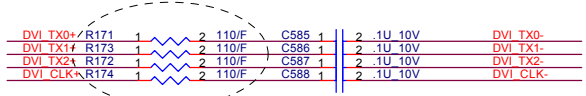
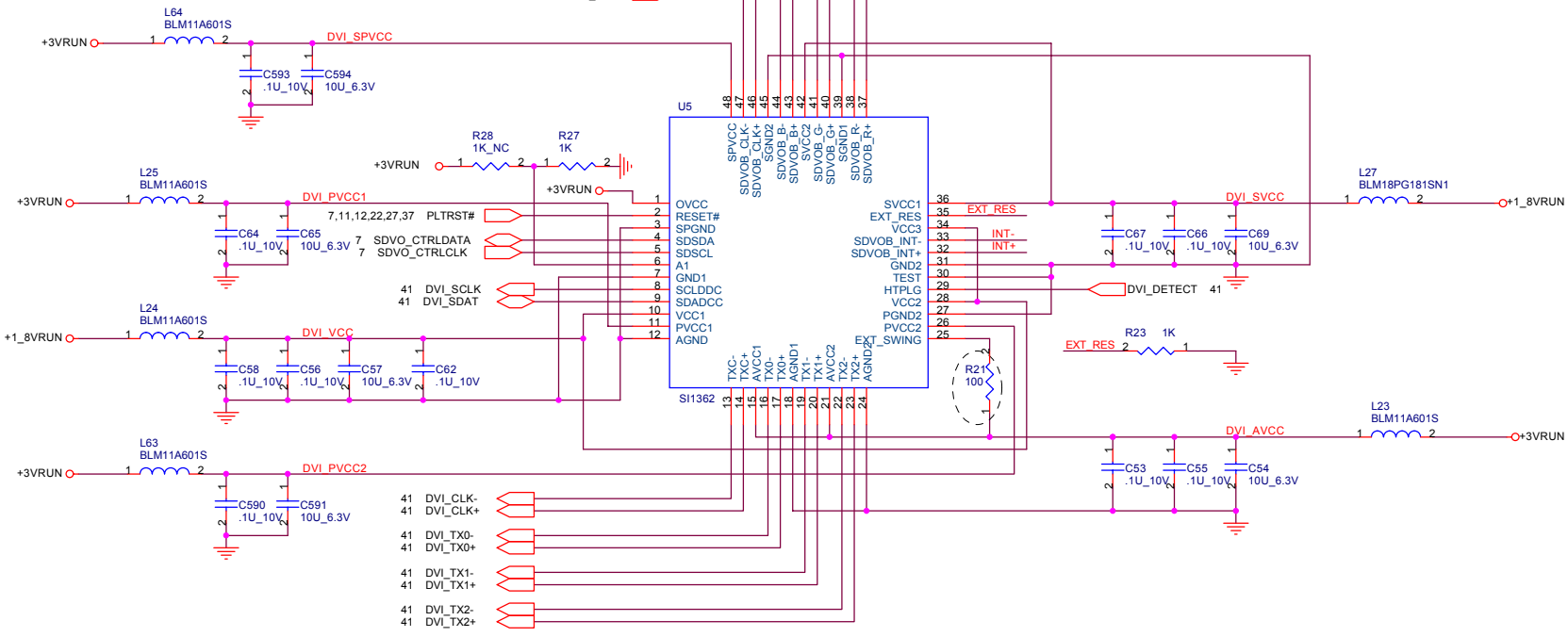
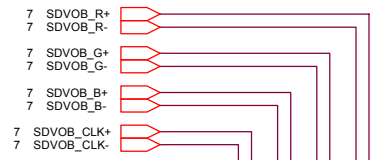
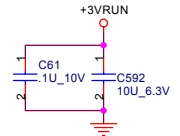

Put these 4 Resistors and 4 Capacitors close to the TX pin of SDVO device



Title		
Sii 1362		
Size	Document Number	Rev
	JMSB	2A
Date:	星期五, 十月 29, 2004	Sheet 17 of 50

**BLANK PAGE**

 <b>QUANTA COMPUTER</b>		
Title		
Size	Document Number	Rev
	JMSB	1A
Date:	星期五, 十月 29, 2004	Sheet 18 of 50

**BLANK PAGE**

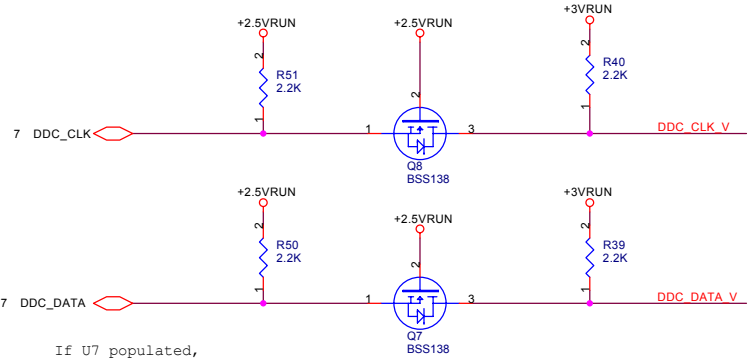
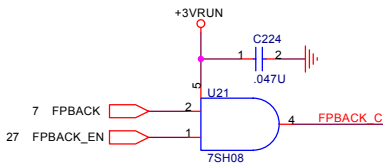
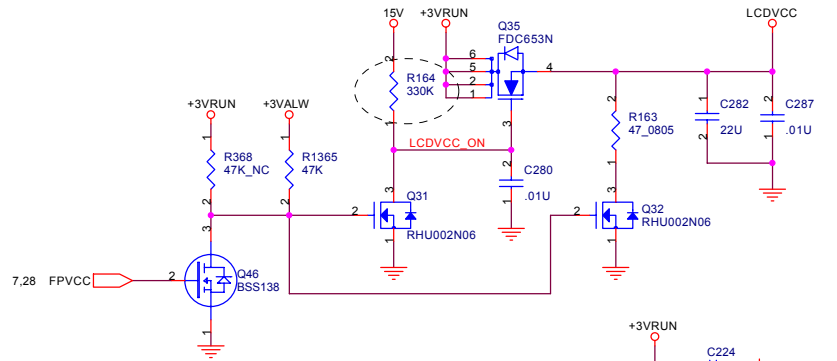

If U7 populated,  
R379=NC; If U7=NC,  
R379=0-ohm

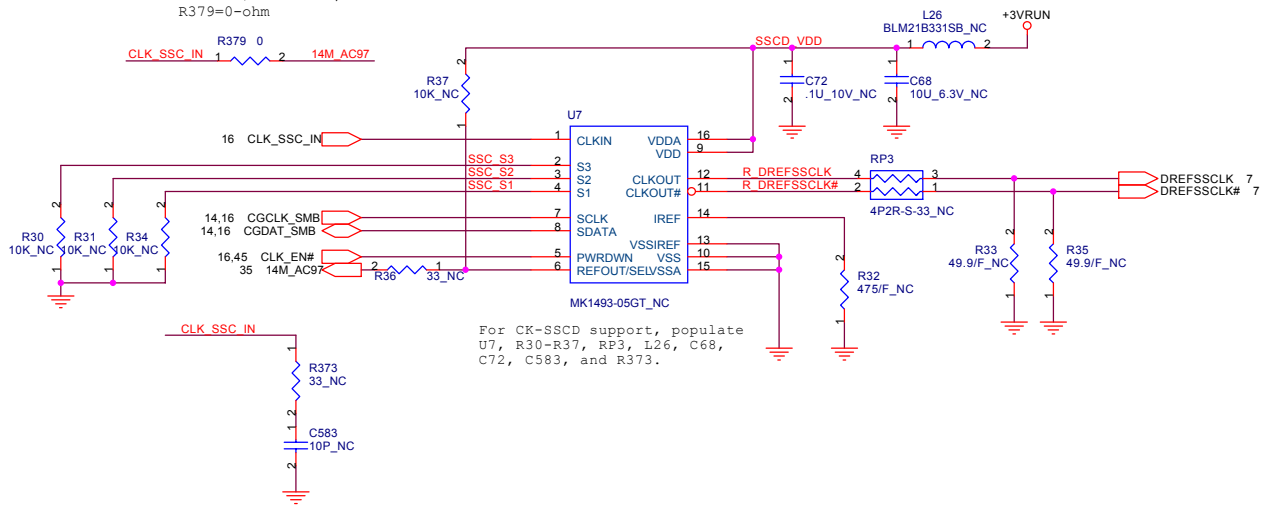

For CK-SSCD support, populate  
U7, R30-R37, RP3, L26, C68,  
C72, C583, and R373.

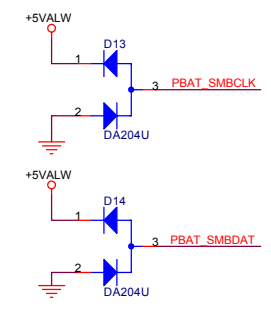
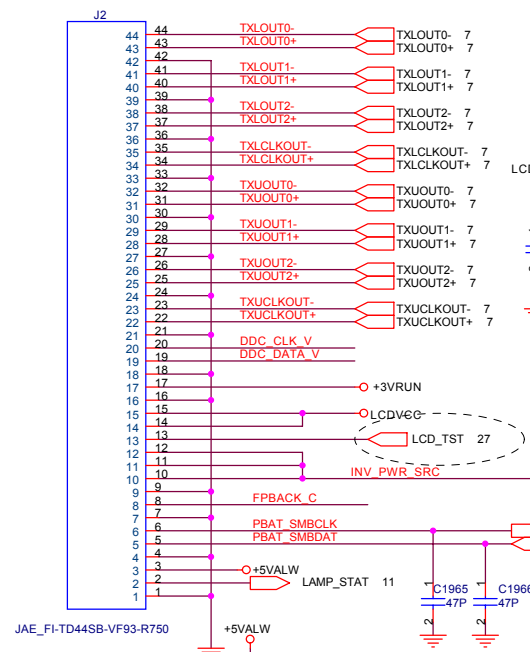

Adress : A9H --Contrast  
AAH --Backlight

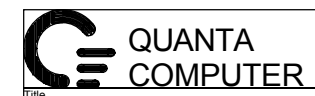
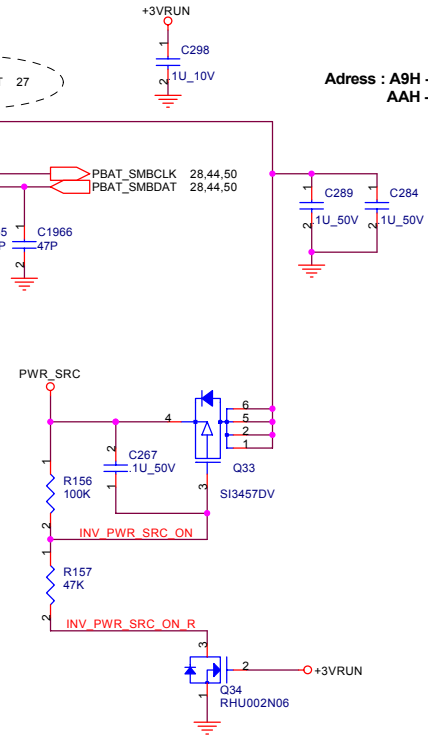

Title LCD CONN&CK-SSCD		
Size JM5B	Document Number JM5B	Rev 2A
Date 星期五, 十月 29, 2004	Sheet 20	of 50

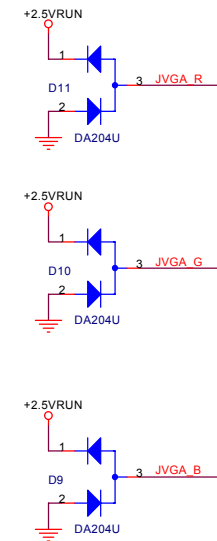
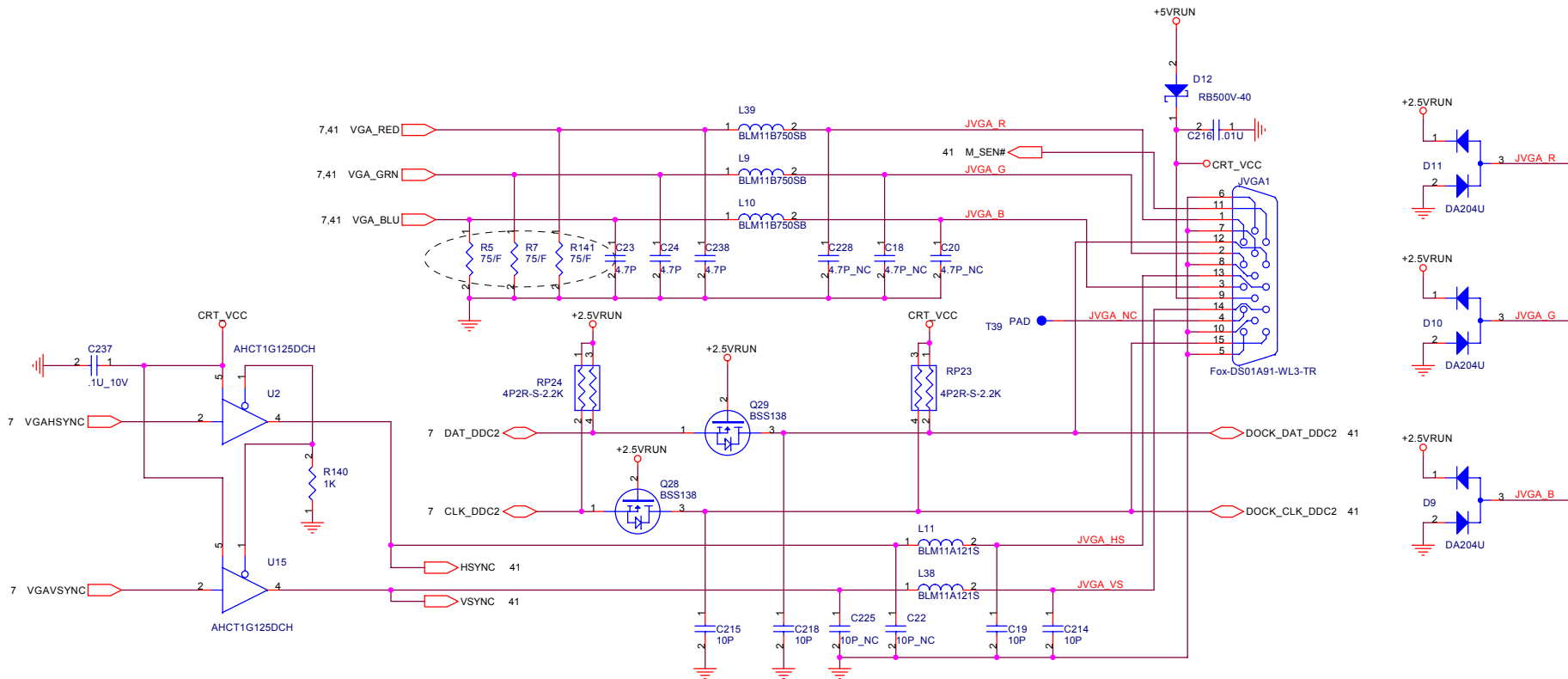

Title CRT&TV CONN		
Size	Document Number JM5B	Rev 2A
Date:	星期五, 十月 29, 2004	Sheet 21 of 50

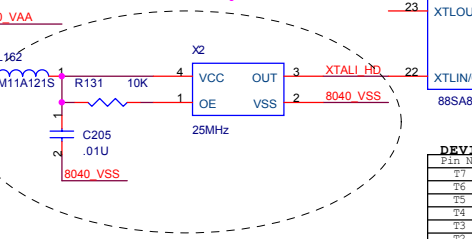
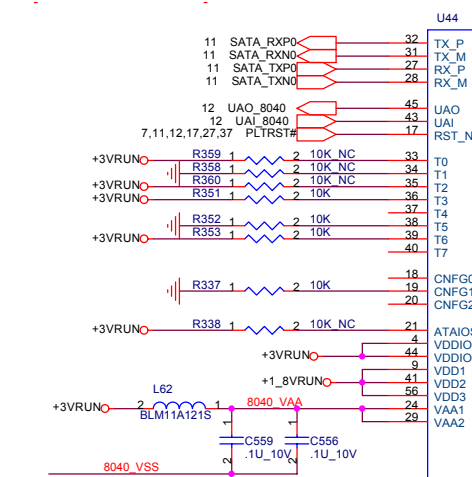
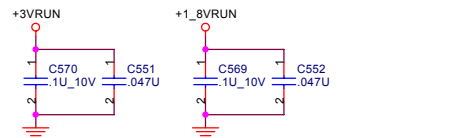

**DEVICE CONFIGURATION**

Pin Name	Pin#	Settings
T7	40	NC
T6	39	1/NC
T5	38	0
T4	37	NC
T3	36	1/NC
T2	35	1/NC
T1	34	0/NC
T0	33	1/NC
CNFG[2:0]	20, 19, 18	NC, 0, NC
ATAIOSEL	21	1/NC
H_PDIA0 N	46	0
H_IOCS16 N	52	1/NC

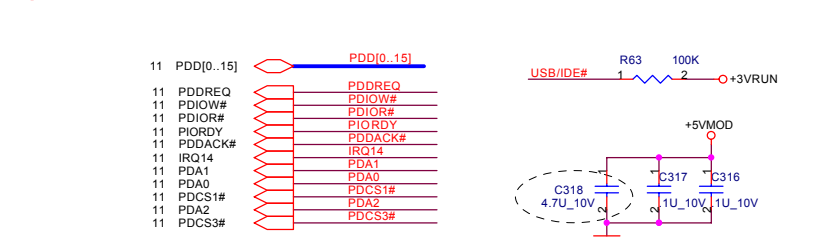
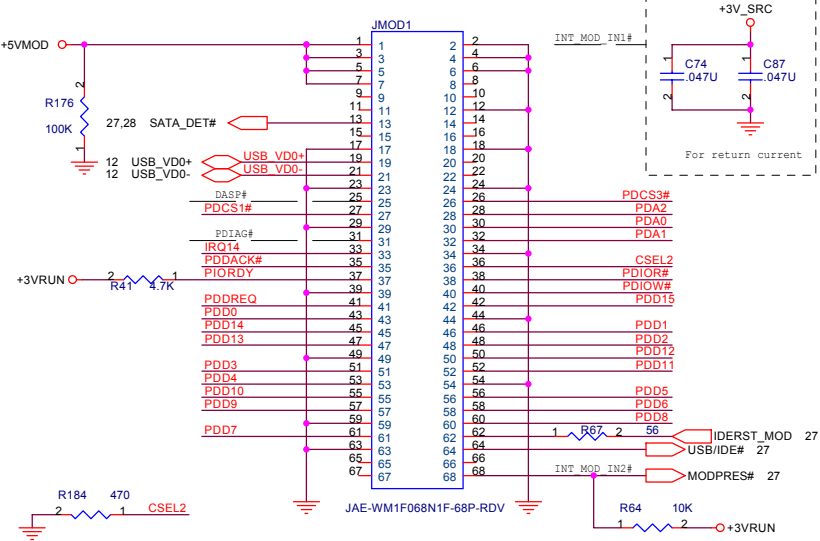
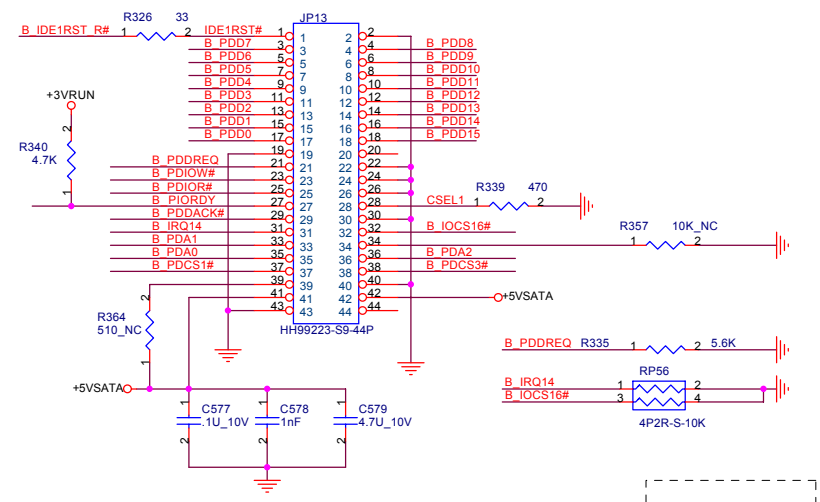
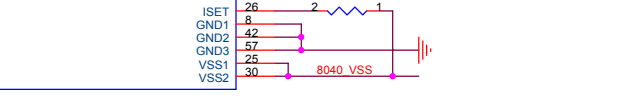
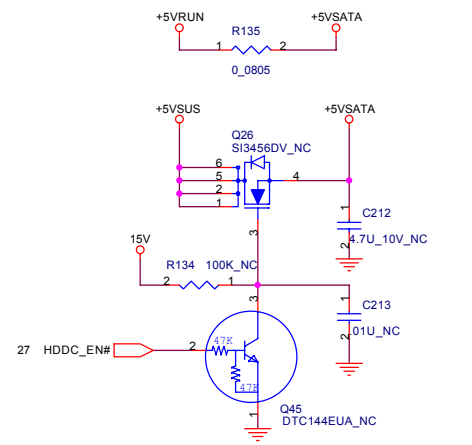

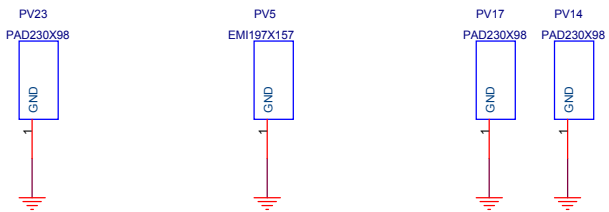
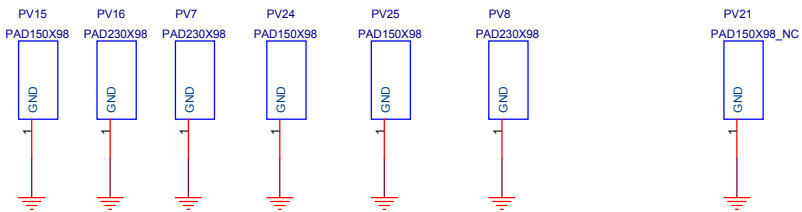
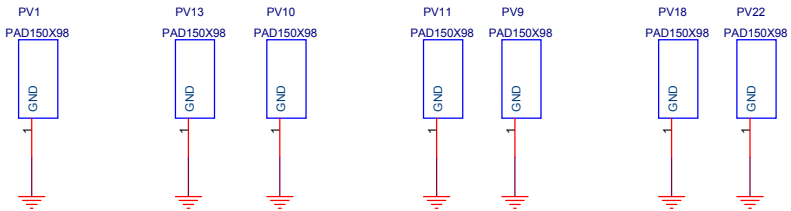
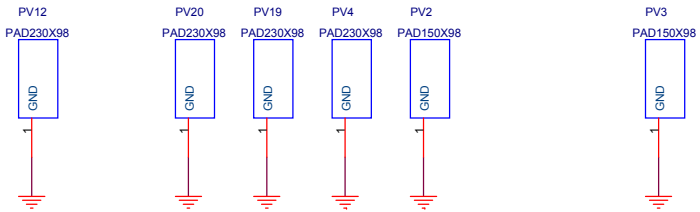

FOR AUDIO

FOR DOCKING

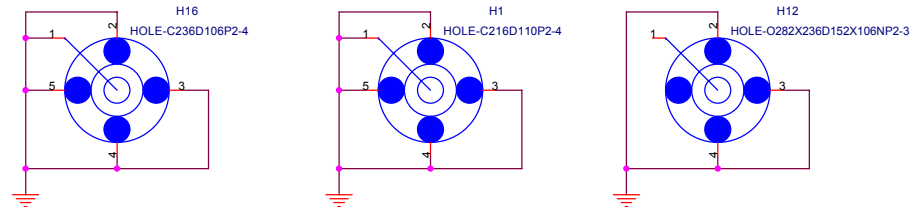
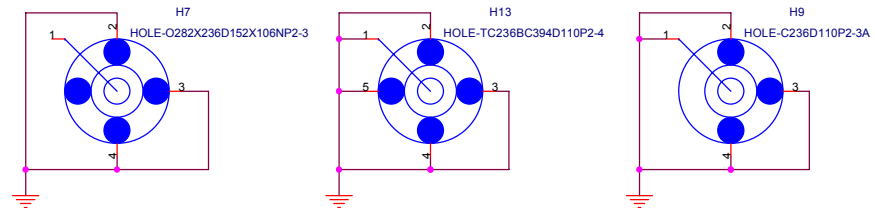
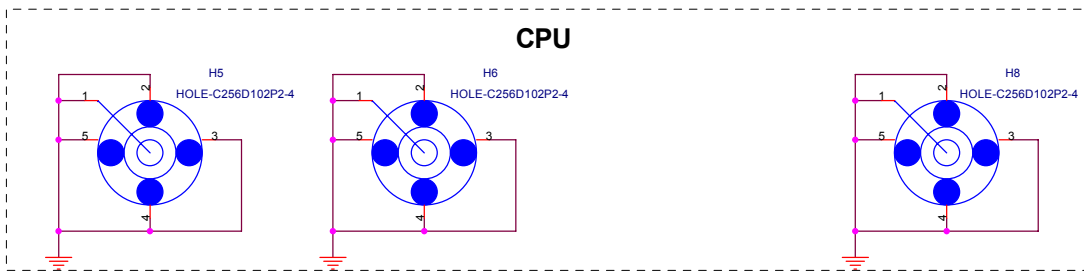

**HEAT SINK**

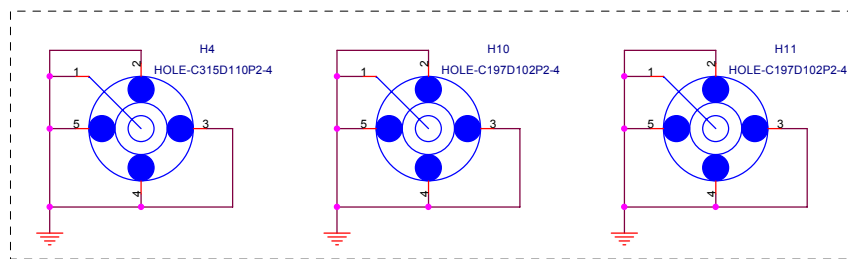

**HDD**

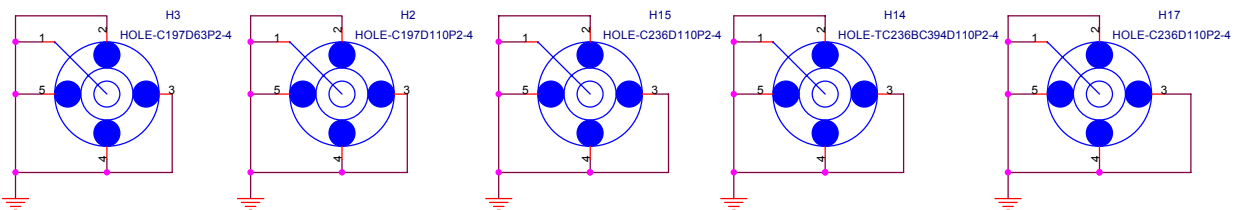

QUANTA COMPUTER		
Title SCREW PAD		
Size	Document Number JM5B	Rev 2A
Date: 星期五, 十月 29, 2004	Sheet 23	of 51





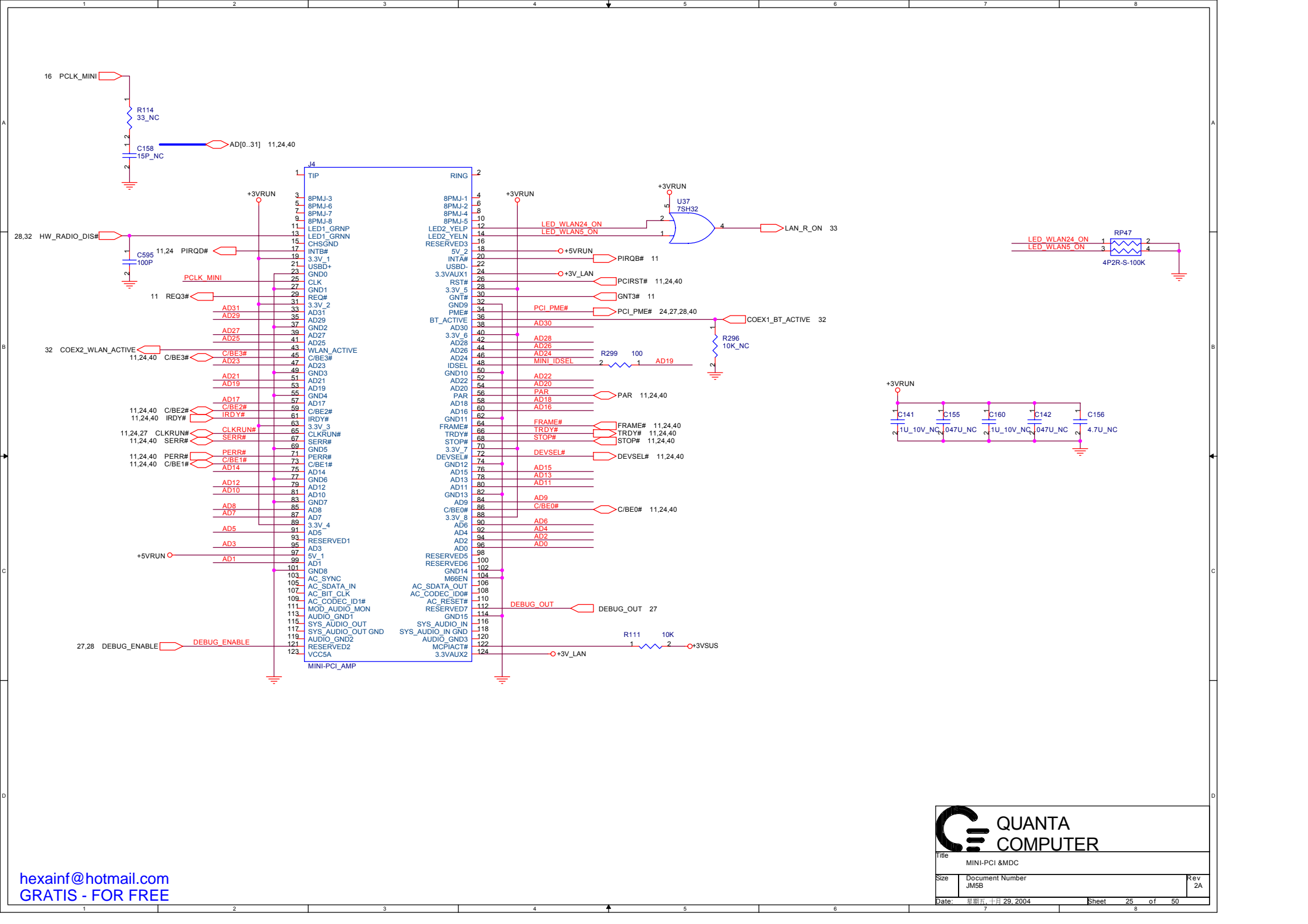

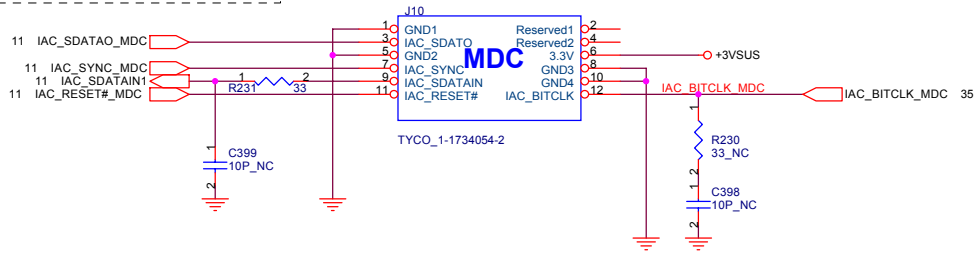
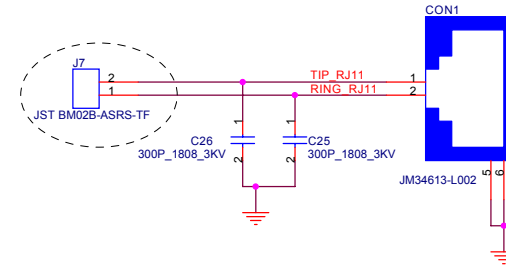
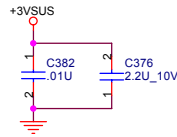
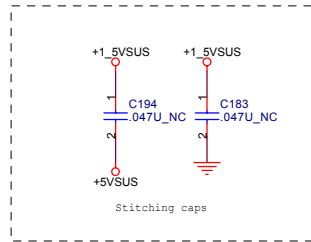

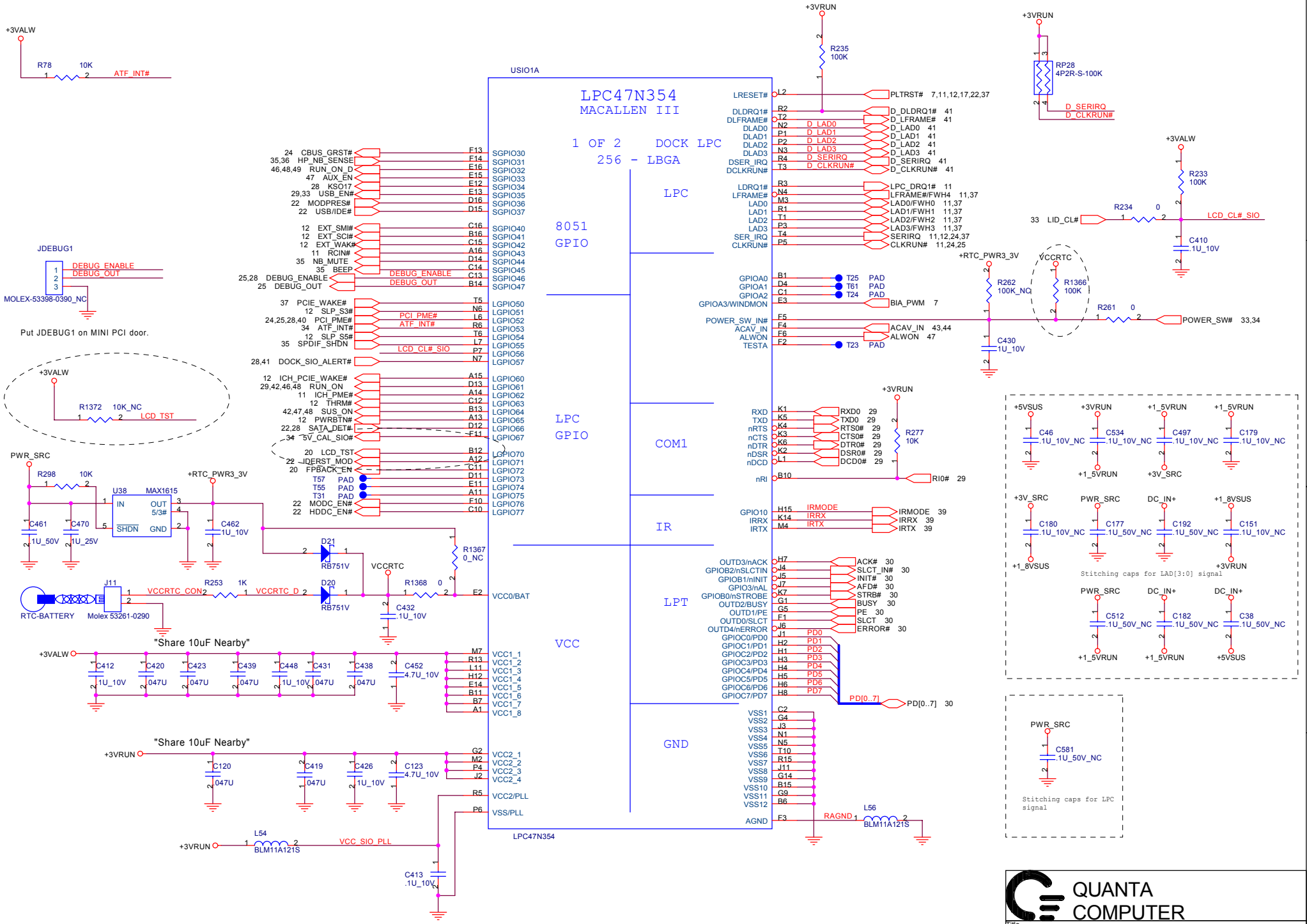

hexainf@hotmail.com  
 GRATIS - FOR FREE

**QUANTA COMPUTER**

Title: Ultra I/O Controller LPC47N254

Size	Document Number JMSB	Rev 2A
------	-------------------------	-----------

Date: 星期日, 十月 29, 2004 Sheet 27 of 50

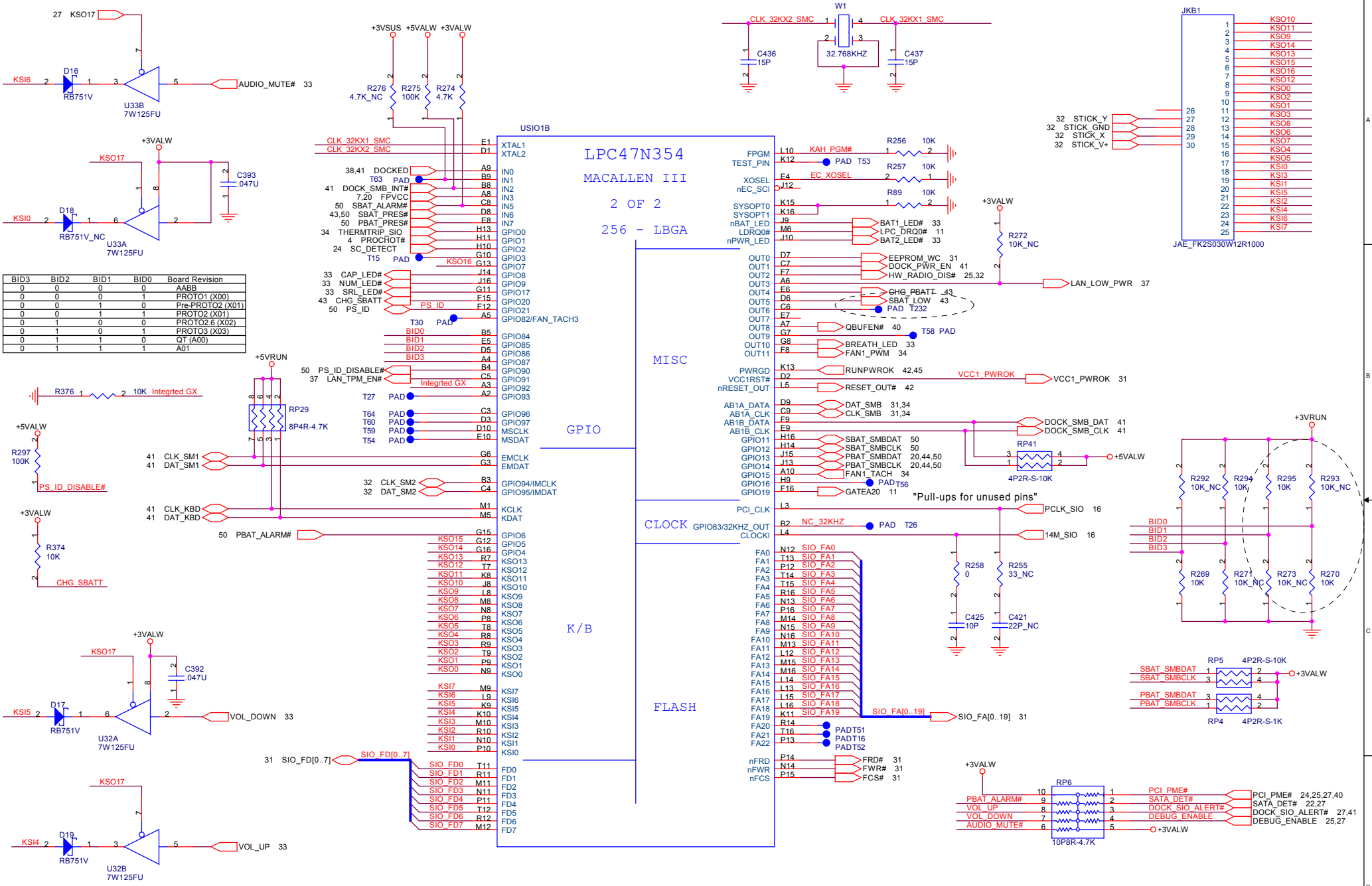

BID3	BID2	BID1	BID0	Board Revision
0	0	0	0	AABB
0	0	1	0	PROTO1 (X00)
0	0	1	0	Pre-PROTO2 (X01)
0	0	1	1	PROTO2 (X01)
0	1	0	0	PROTO2.6 (X02)
0	1	0	1	PROTO3 (X03)
0	1	1	0	QT (A00)
0	1	1	1	A01

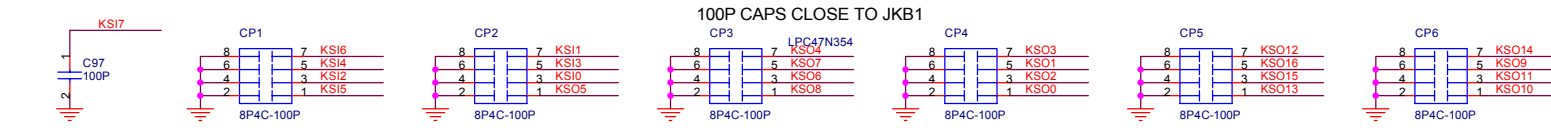
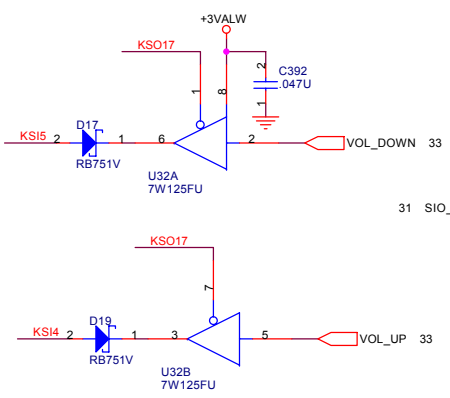
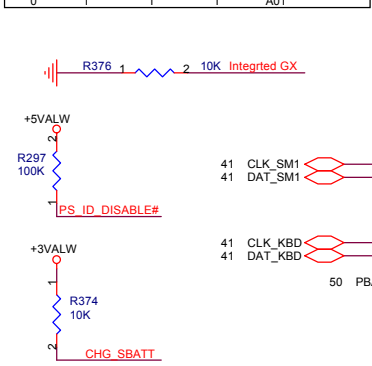

## QUANTA COMPUTER

Title Ultra I/O Controller LPC47N254(GPIO/KB/MISC/FLASH)

Size	Document Number JMSB	Rev 2A
Date:	星期五, 十月 29, 2004	Sheet 28 of 50

A

B

C

D

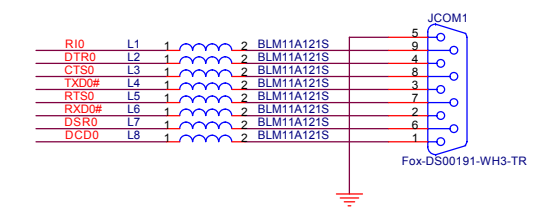
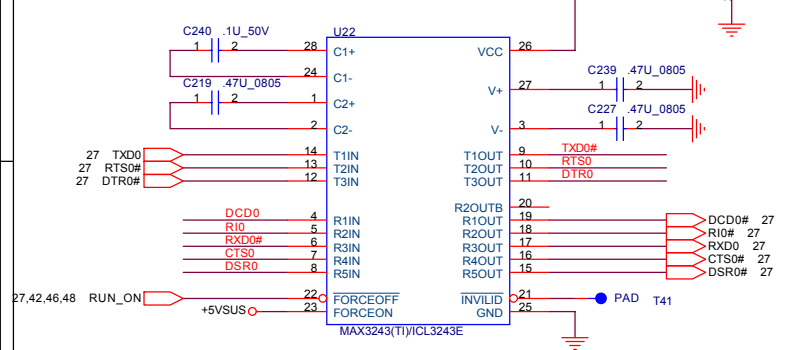

Place these beads close to JCOM1 as soon as possible

If MAX3243 pin 22 tied to RUN\_ON, then it can not support Ring Out

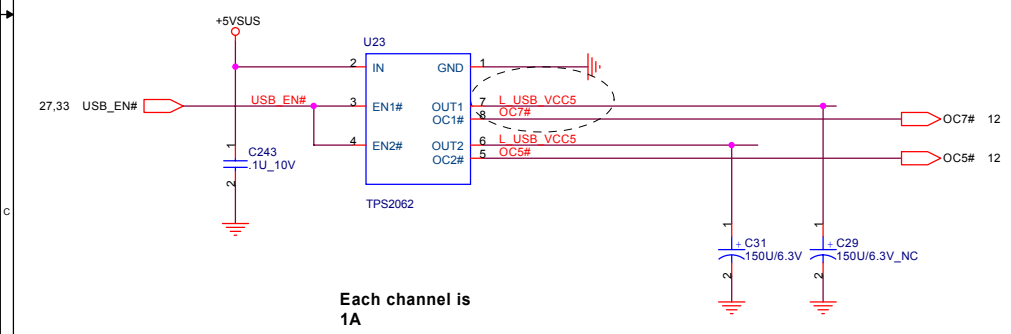

Each channel is 1A

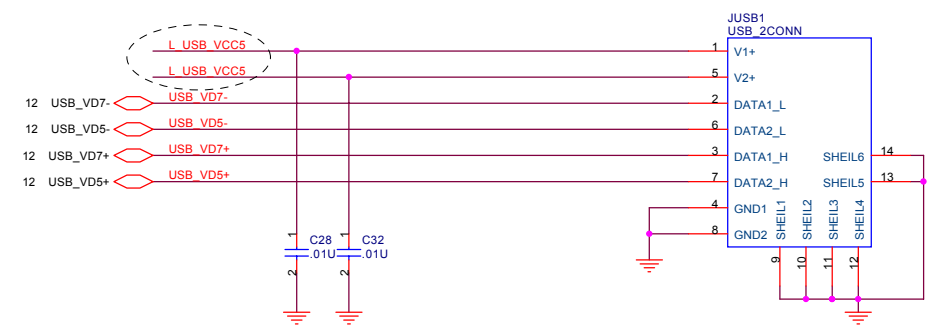

**QUANTA COMPUTER**

Title SERIAL PORT & USB

Size Document Number JMSB Rev 2A

Date: 星期五, 十月 29, 2004 Sheet 29 of 50

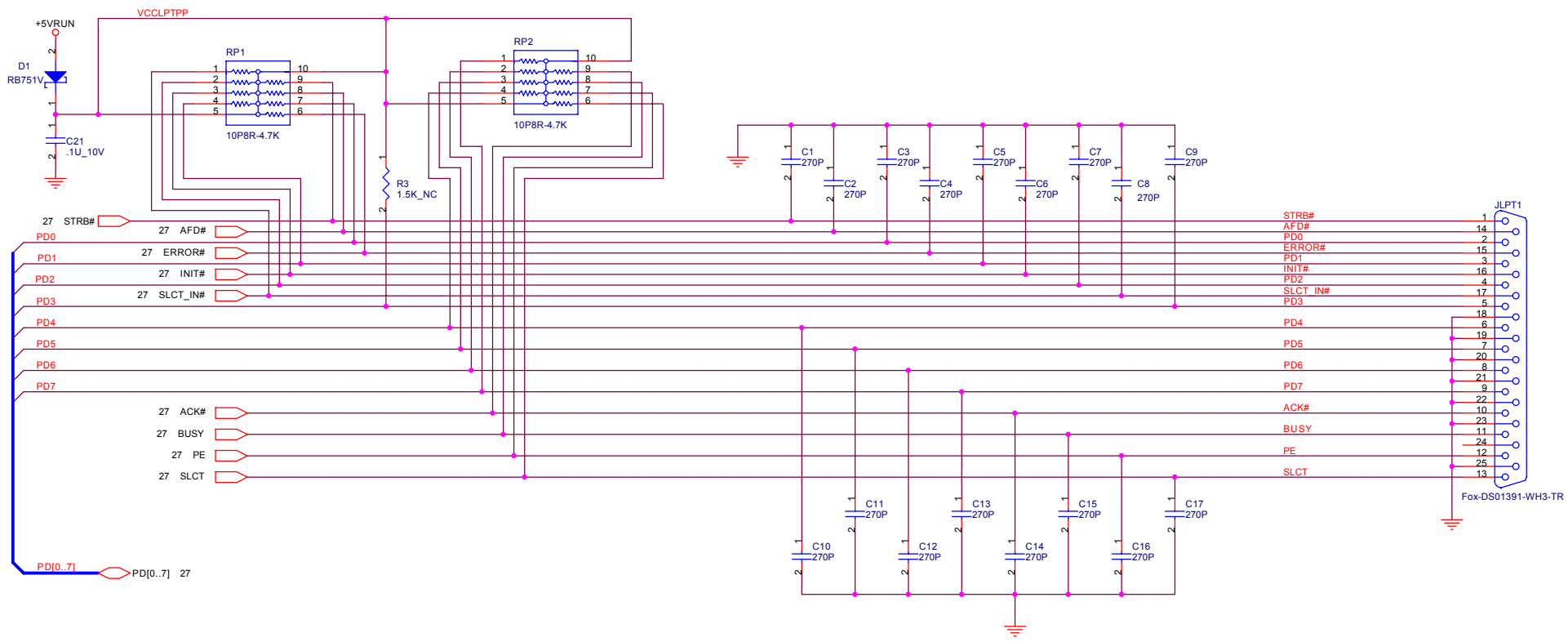

### 8Mbit (1M Byte),NO PLCC TYPE

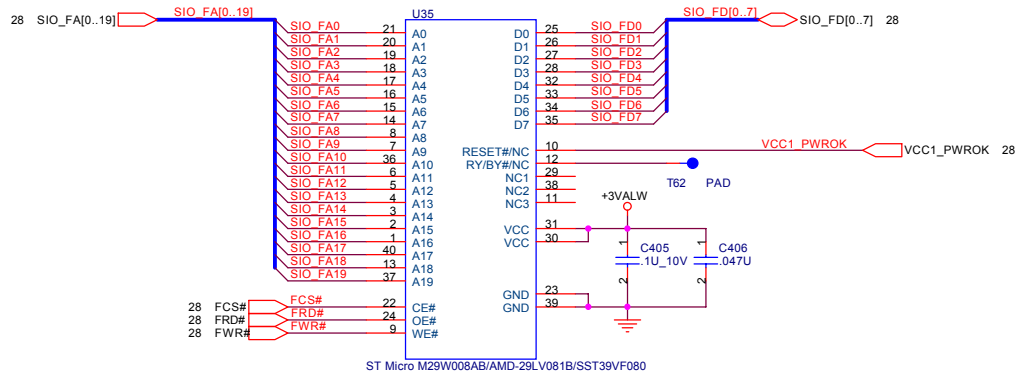

ST Micro M29W008AB/AMD-29LV081B/SST39VF080

**AMD :Pin 10 is RESET# ; Pin12 is RY/BY#**  
**SST :Pin10,12 are NC**

- 1.AMD-29LV081B require MAX 500nS Tready for it's hardware reset.And MAX6326\_UR29 has >100mS reset timing.So we can tie it's reset# pin to +3VALW directly.
- 2.SIO has internal 20 mS delay of VCC1\_PWROK

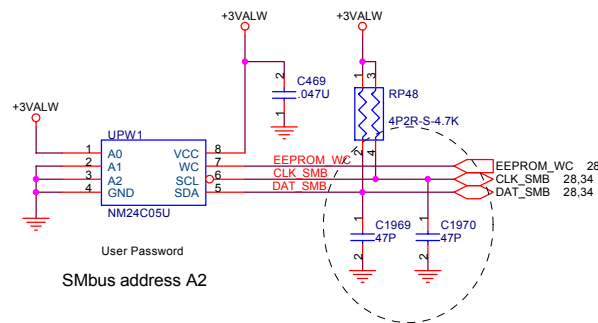

User Password  
SMBus address A2

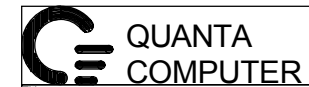

Title FLASH		
Size	Document Number JMSB	Rev 2A
Date:	星期五, 十月 29, 2004	Sheet 31 of 50

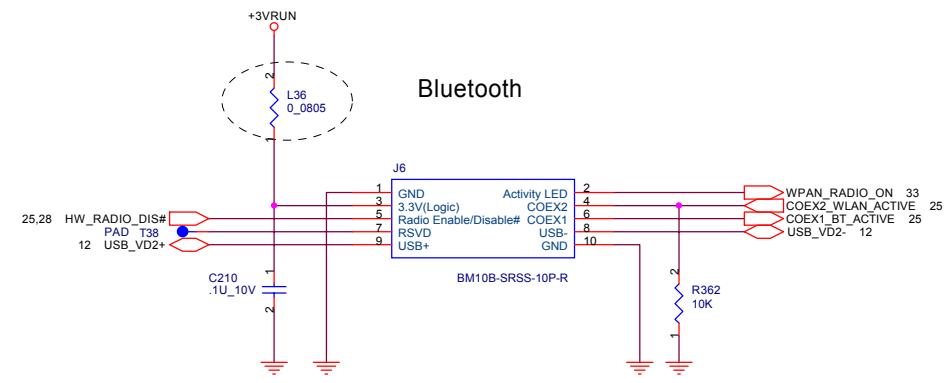
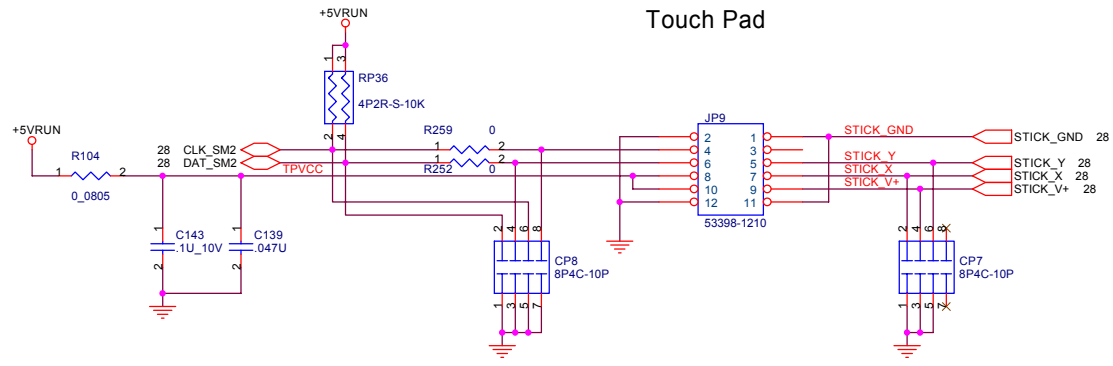



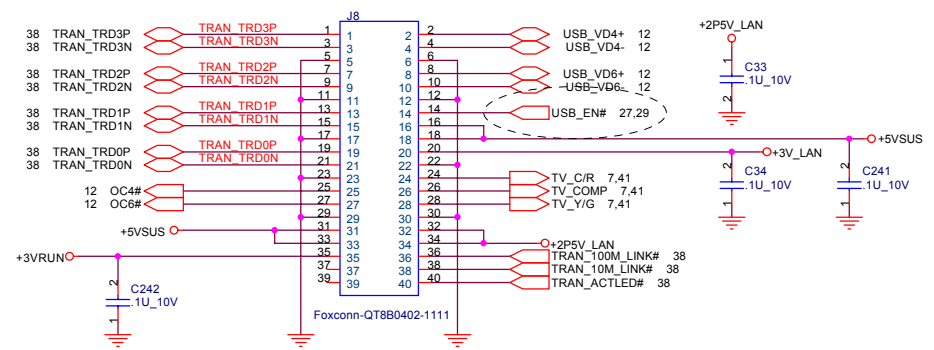
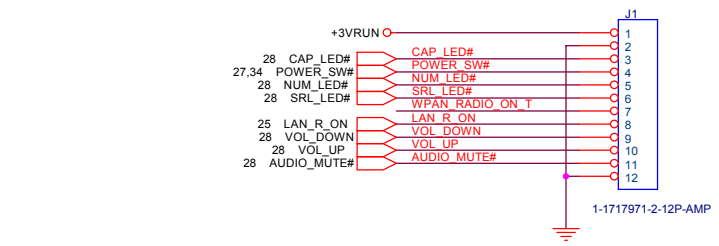
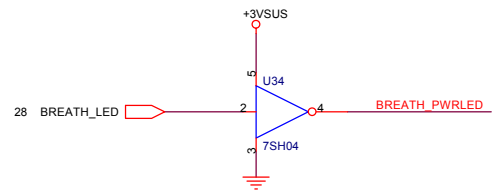
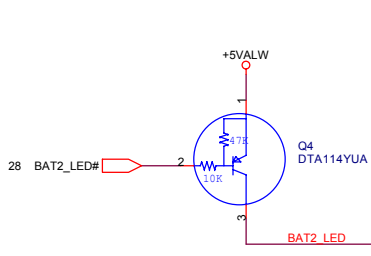
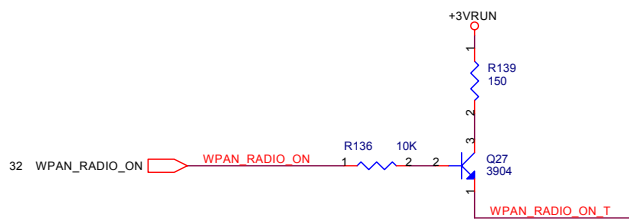
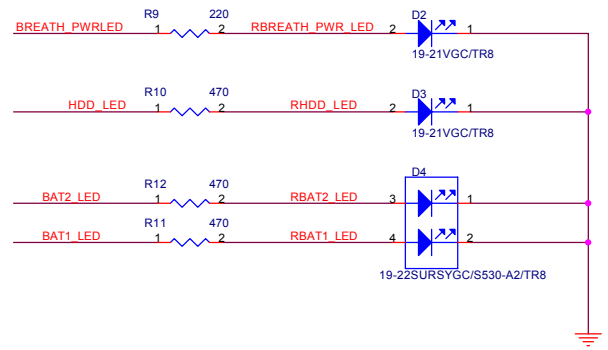
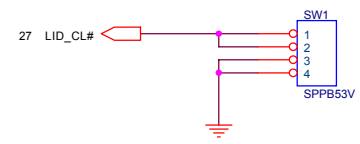
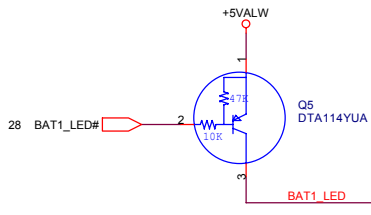
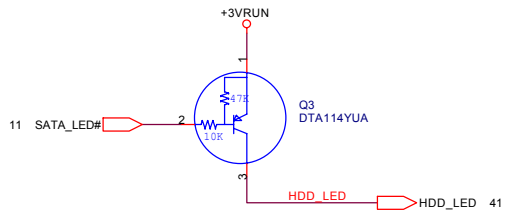

Title SWITCH & LED		
Size	Document Number JMSB	Rev 2A
Date:	星期五, 十月 29, 2004	Sheet 33 of 50

hexainf@hotmail.com  
GRATIS - FOR FREE

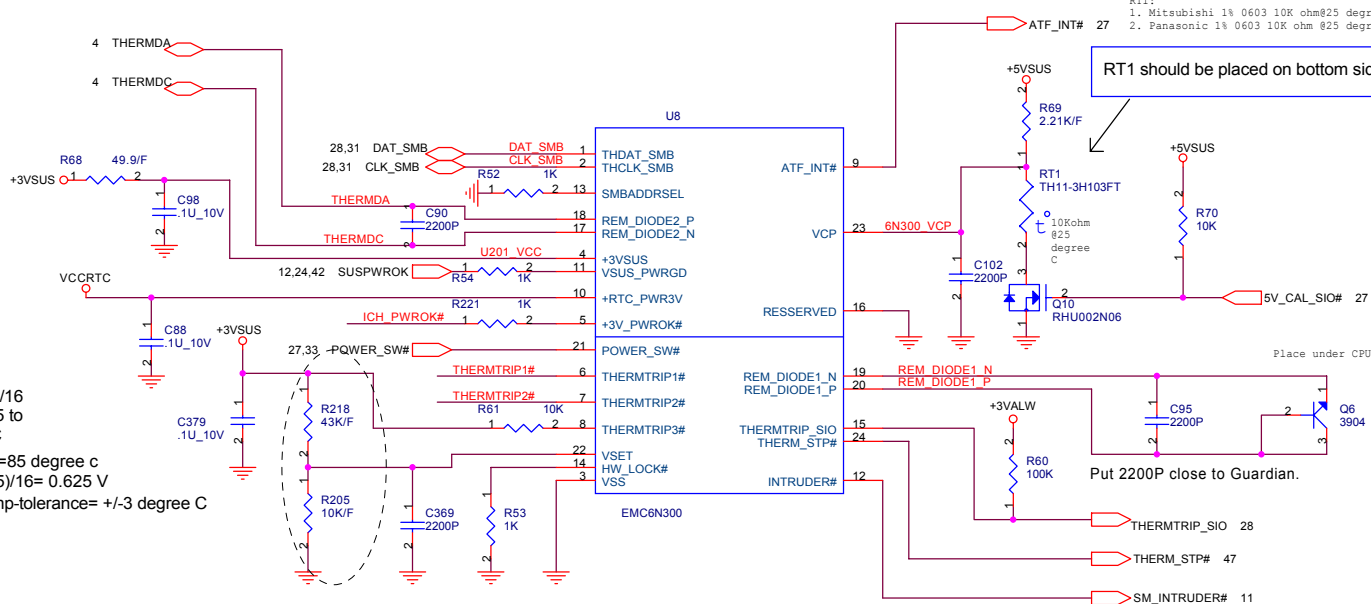
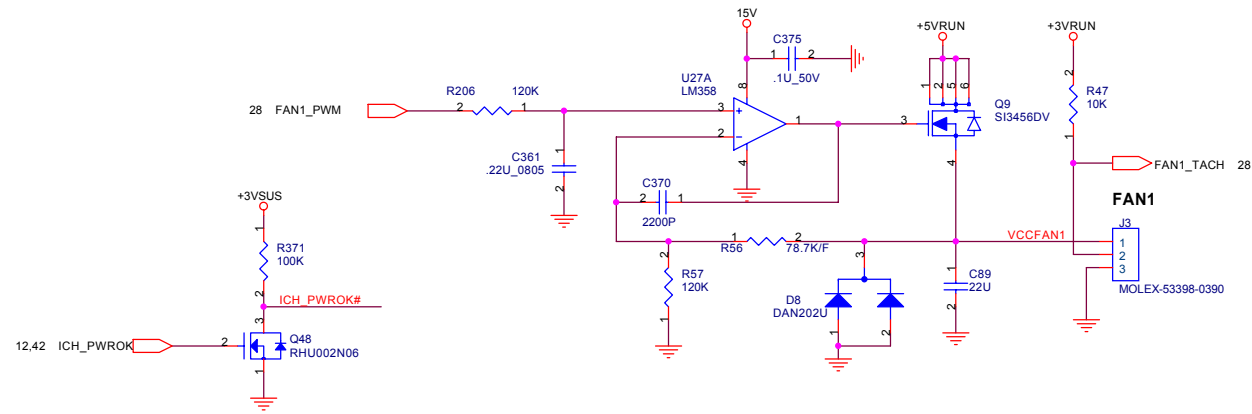

- RT1:  
 1. Mitsubishi 1% 0603 10K ohm@25 degree C. P/N: TH11-3H103FT  
 2. Panasonic 1% 0603 10K ohm @25 degree C. P/N:ERTJ1VGI03FA

RT1 should be placed on bottom side of MB between MB and Sodimm

Notes:  
 $V_{set} = (T_p - 75) / 16$   
 Where  $T_p = 75$  to  $106$  degree C  
 Set trip point =  $85$  degree C  
 $V_{set} = (85 - 75) / 16 = 0.625$  V  
 Guardian temp-tolerance =  $\pm 3$  degree C

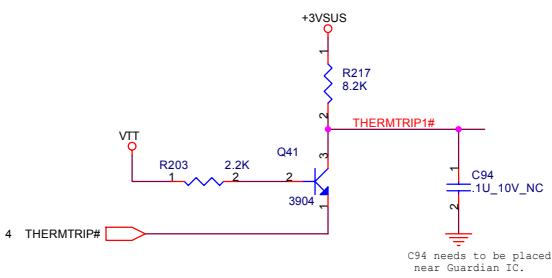

C94 needs to be placed near Guardian IC.

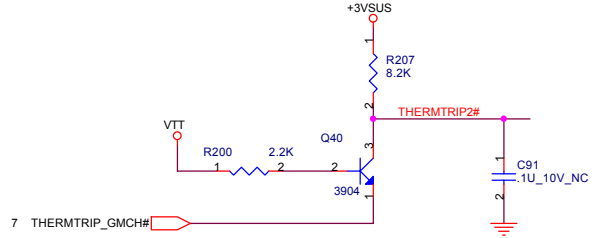

Title FAN & THERMAL		
Size	Document Number JMSB	Rev 2A
Date:	星期五, 十月 29, 2004	Sheet 34 of 50

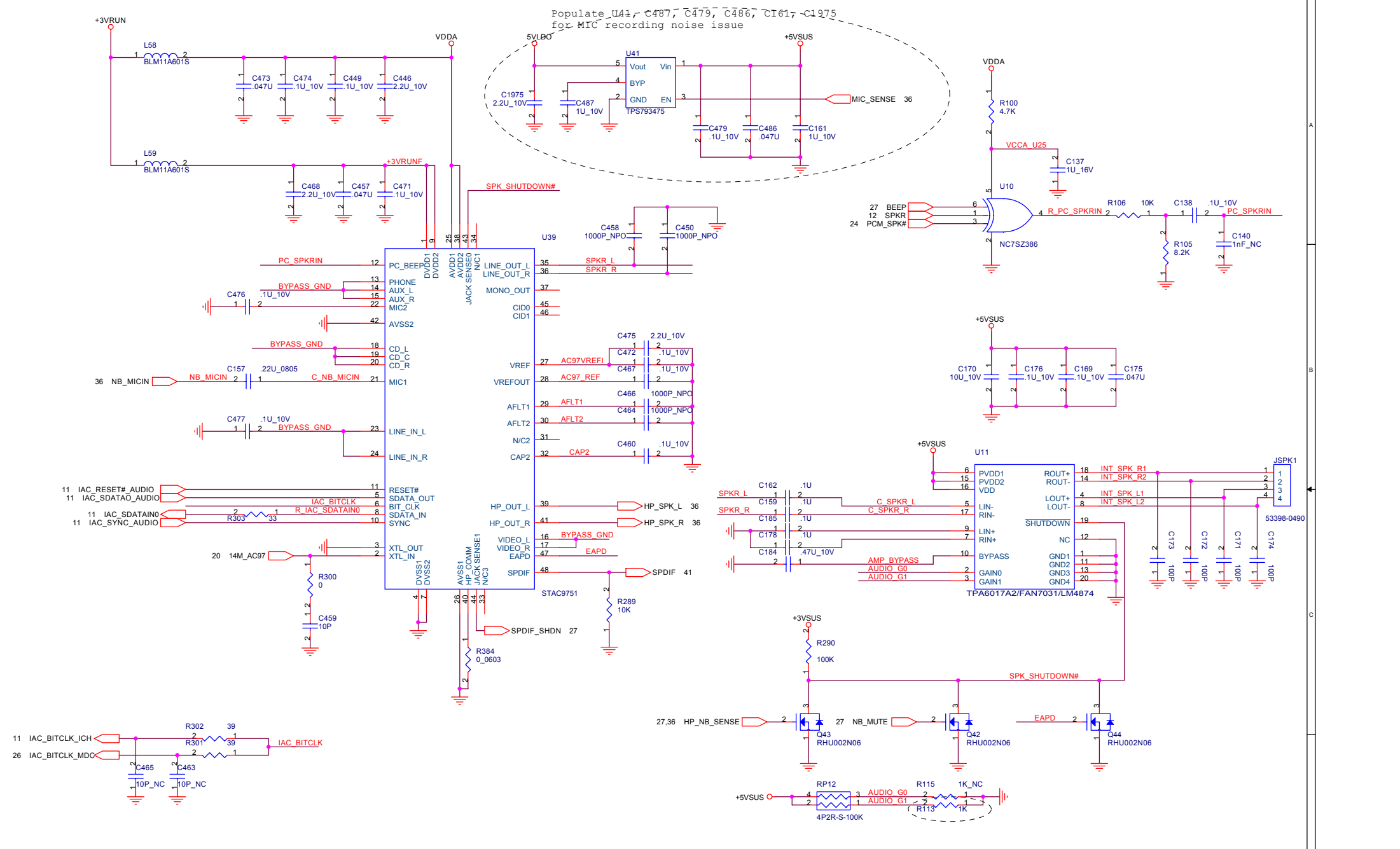

GAIN0	GAIN1	AV
0	0	6dB
0	1	10dB
1	0	15.6dB
1	1	21.6dB



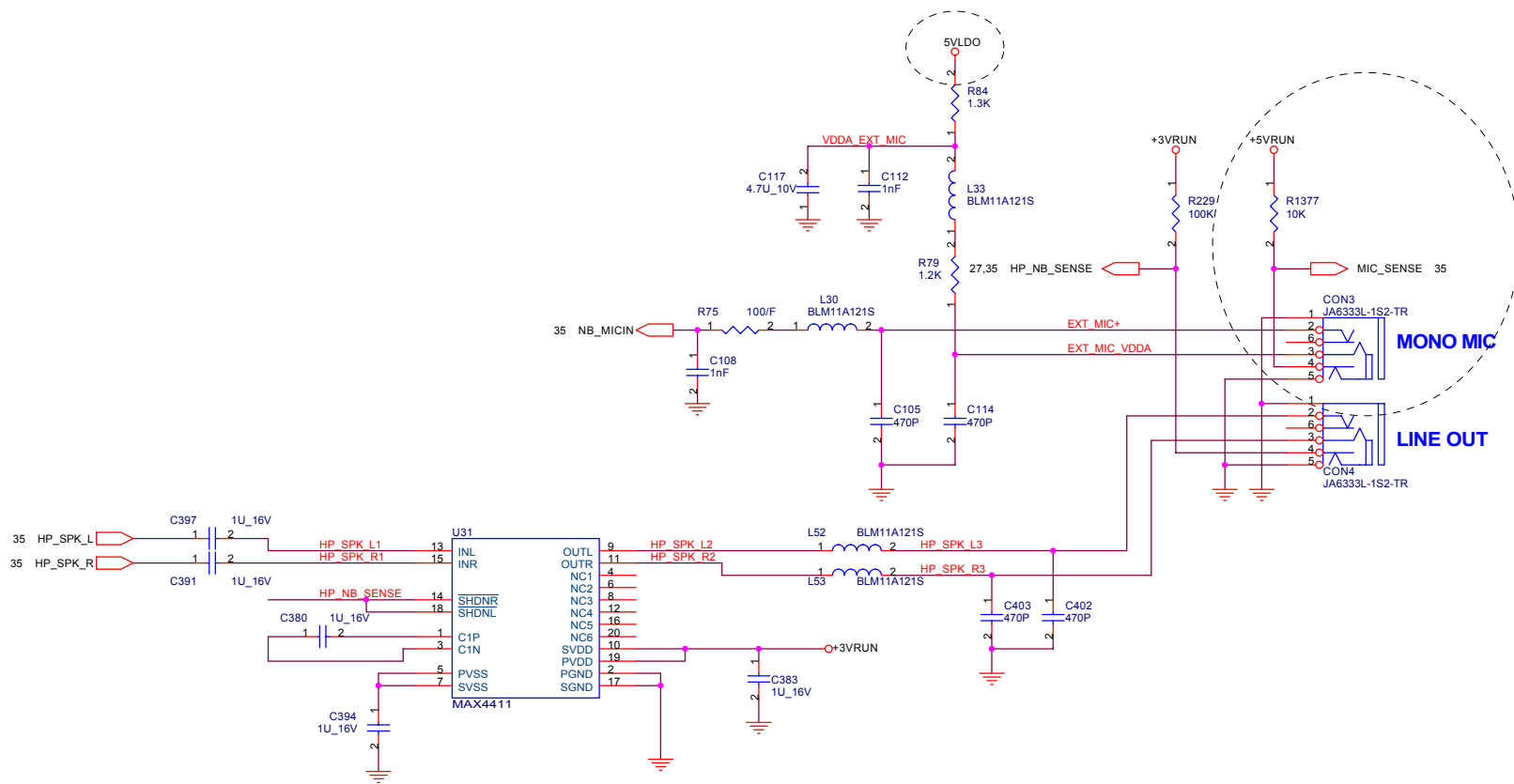

Title		
AUDIO CONN		
Size	Document Number	Rev
	JMSB	2A
Date:	星期五, 十月 29, 2004	Sheet 36 of 50

**U25**  
**BCM5751KFB**  
 15mm x 15mm  
**BGA196**

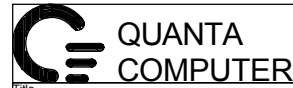
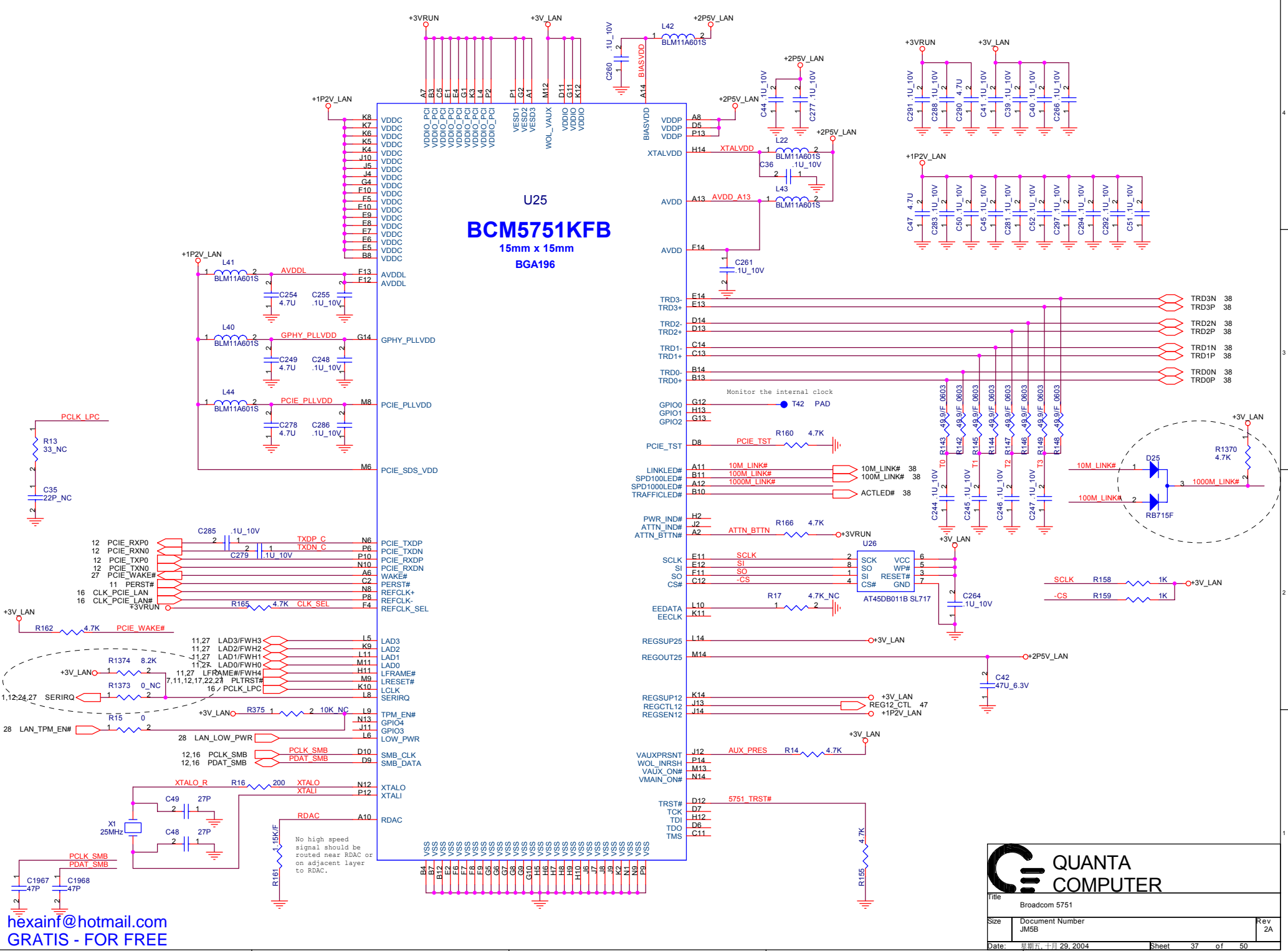

Title Broadcom 5751		
Size	Document Number JMSB	Rev 2A
Date:	星期五, 十月 29, 2004	Sheet 37 of 50

hexainf@hotmail.com  
 GRATIS - FOR FREE

L14/L15/L16/L17/L18/L19/L20/L21 must be 0603

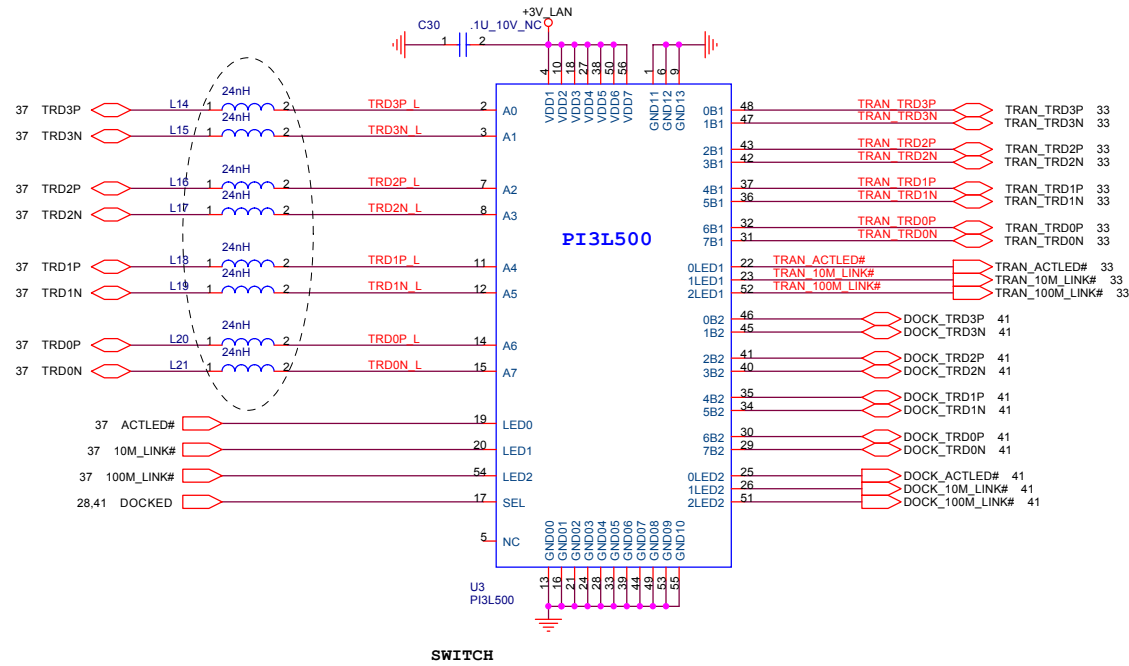

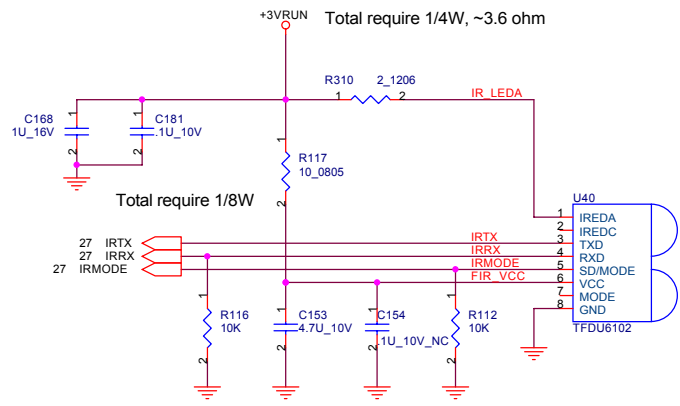

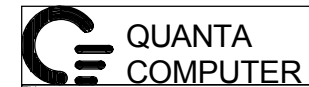
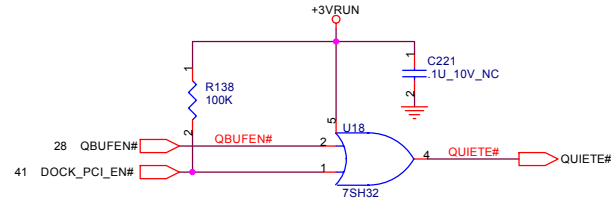
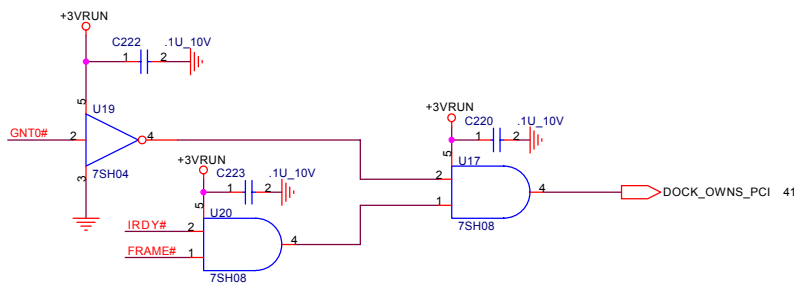
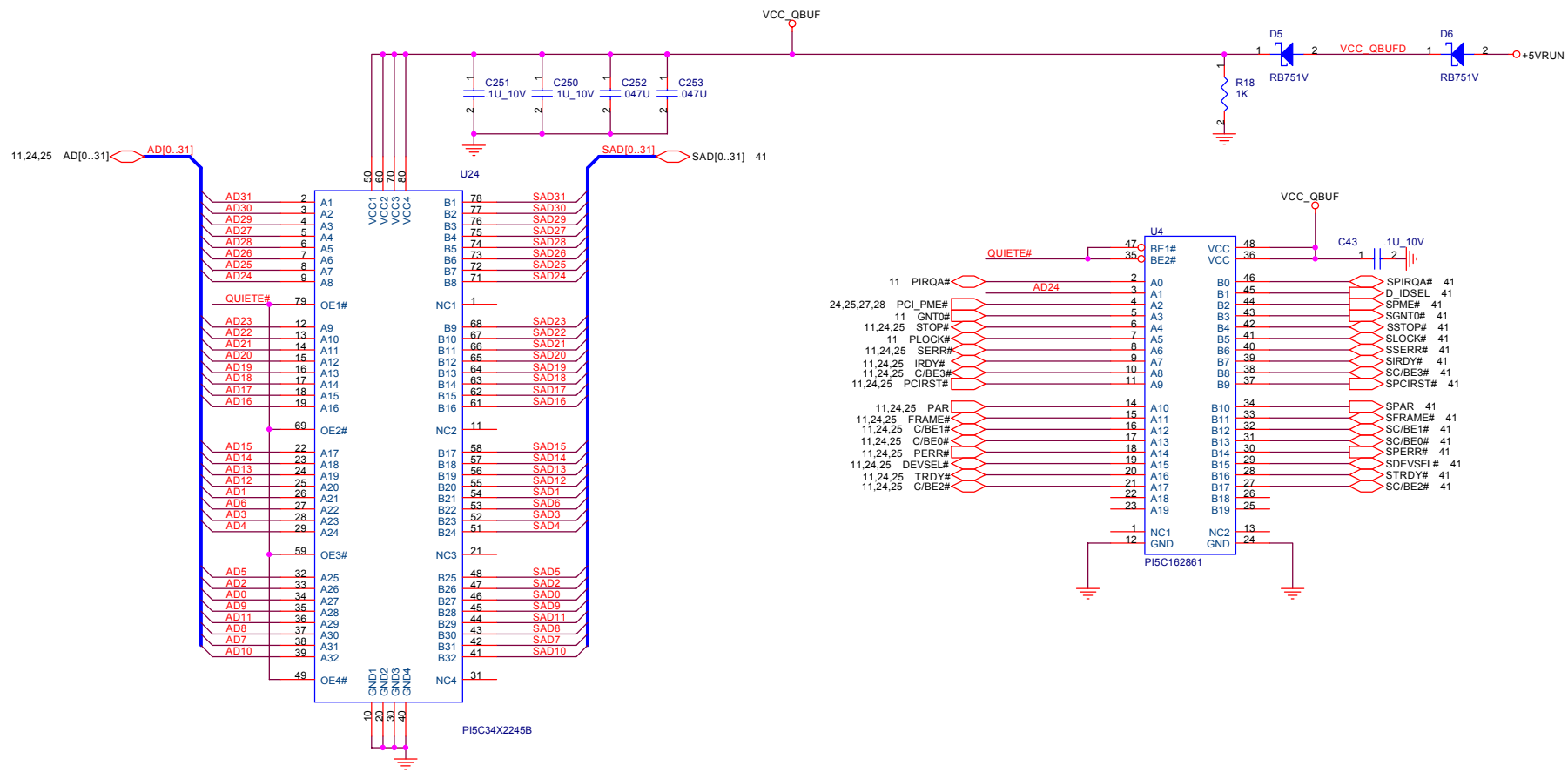





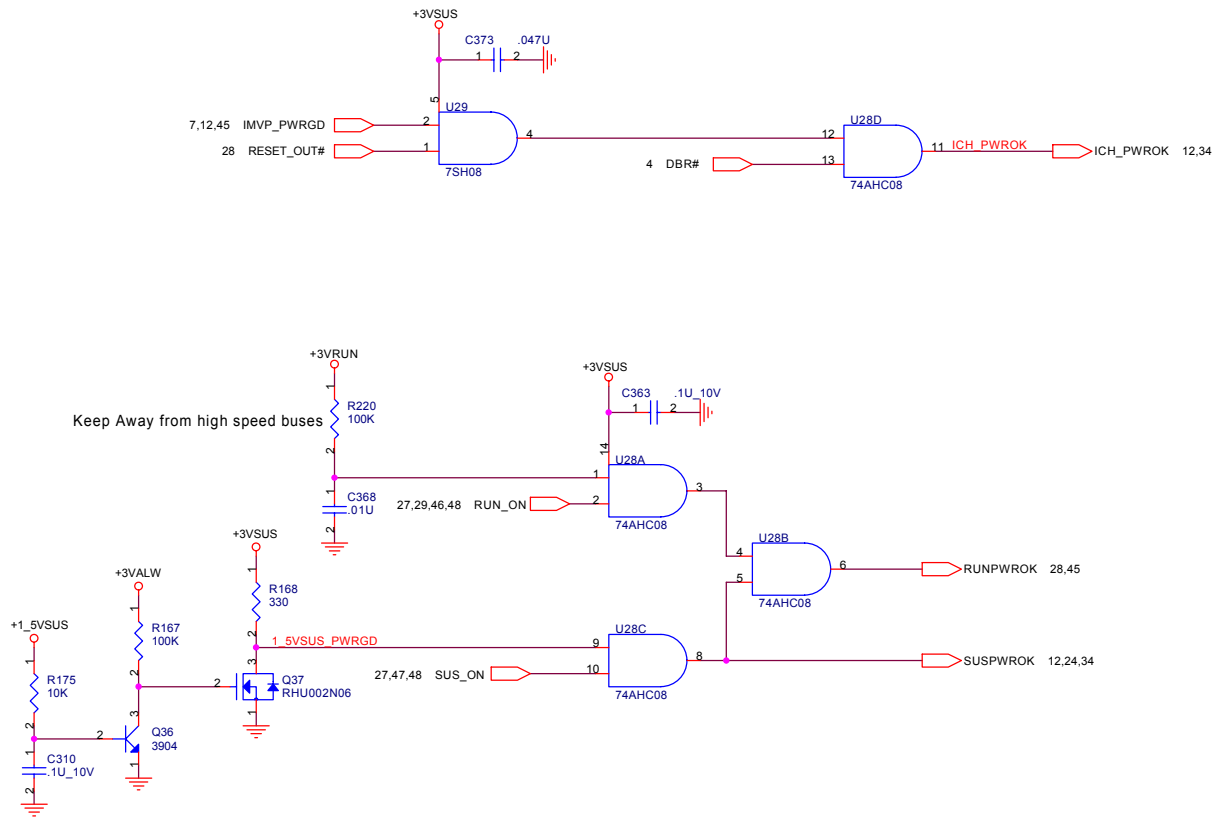

Keep Away from high speed buses

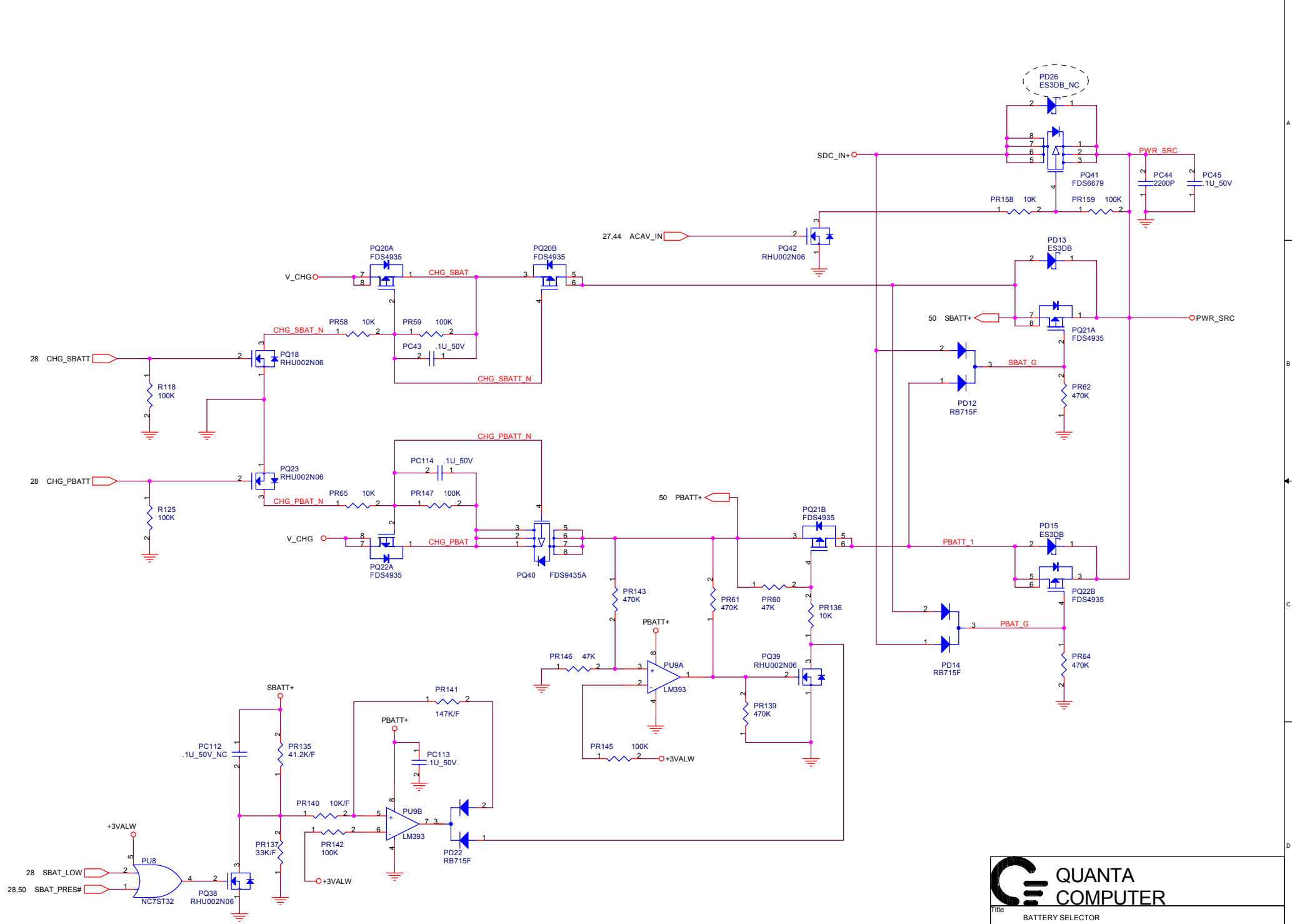

hexainf@hotmail.com  
 GRATIS - FOR FREE



Title BATTERY SELECTOR		
Size	Document Number JM5B	Rev 2A
Date:	星期五, 十月 29, 2004	Sheet 43 of 50

Connect GND side of PC134, PC135, PC131, PC129 and PC133 to GND through 1 via.

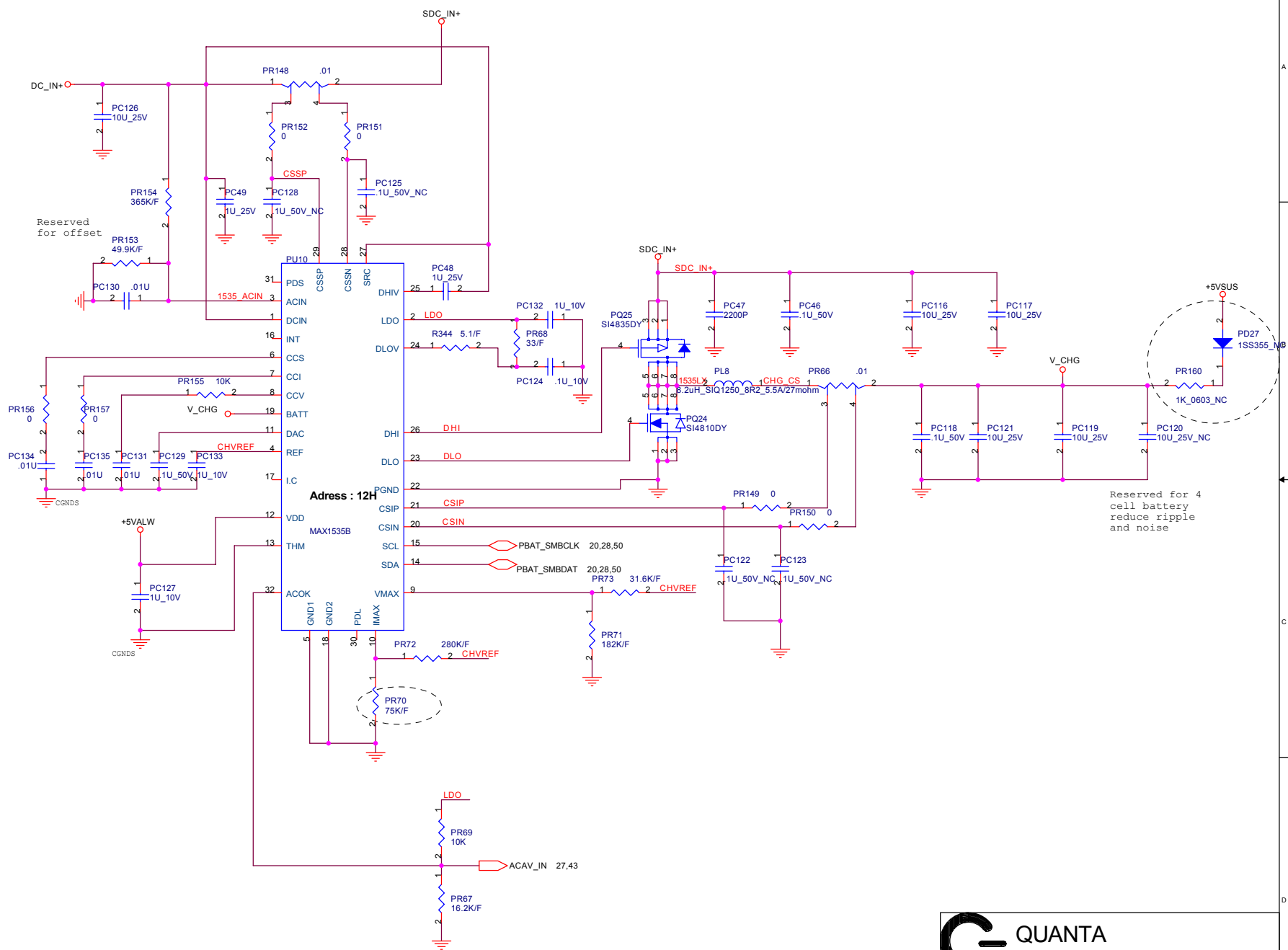

Reserved for 4 cell battery reduce ripple and noise



Title Battery Charger		
Size	Document Number JMSB	Rev 2A
Date	日期: 十月 29, 2004	Sheet 44 of 50







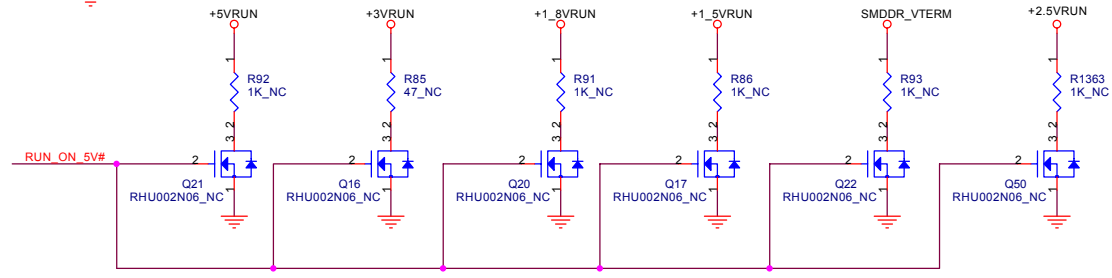
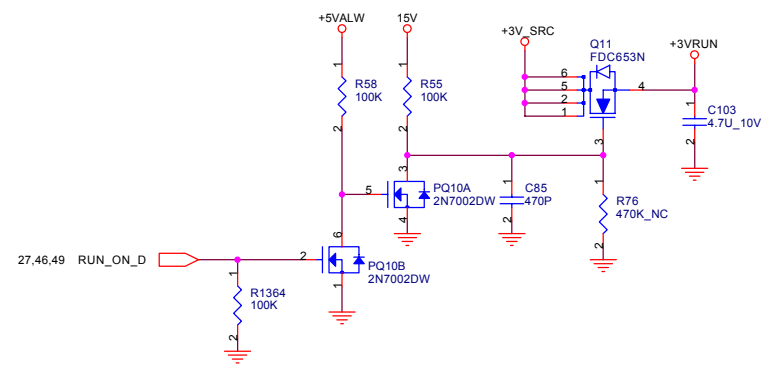
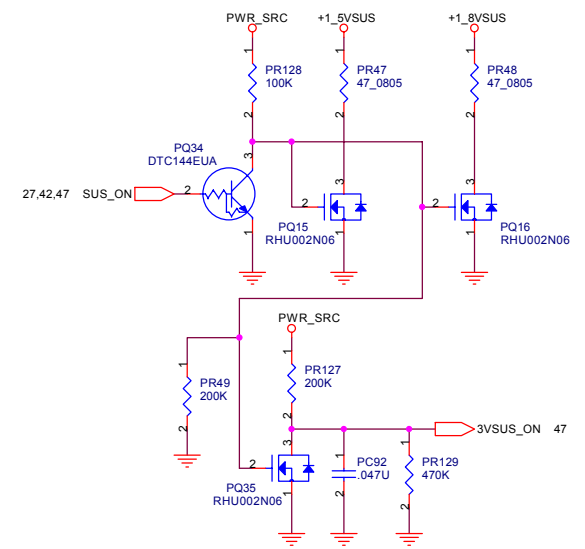
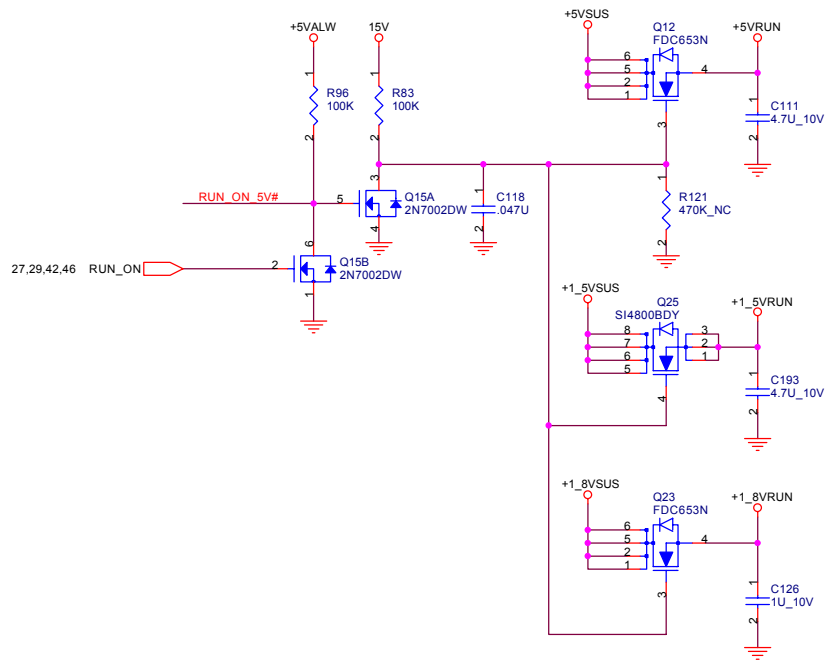

Reserve discharge path

**QUANTA COMPUTER**

Title: RUN POWER SW

Size	Document Number	Rev
	JMSB	2A

Date: 星期五, 十月 29, 2004 Sheet 48 of 50



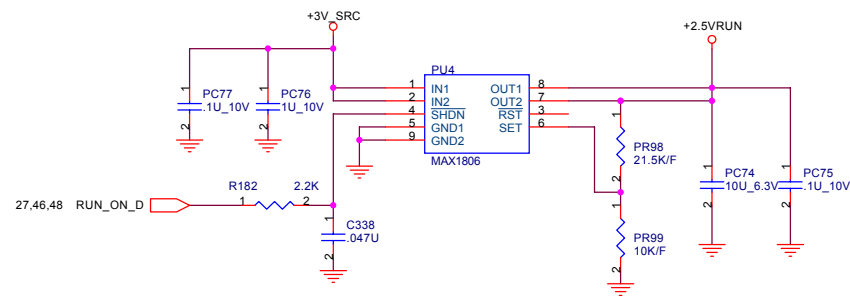

 <b>QUANTA COMPUTER</b>		
Title: VGA DC/DC		
Size:	Document Number: JM5B	Rev: 2A
Date:	星期五, 十月 29, 2004	Sheet 49 of 50

