

Spears AMD UMA Block Diagram

Project code : 91.4W001.001
 PCB P/N : 07210
 Revision : 1

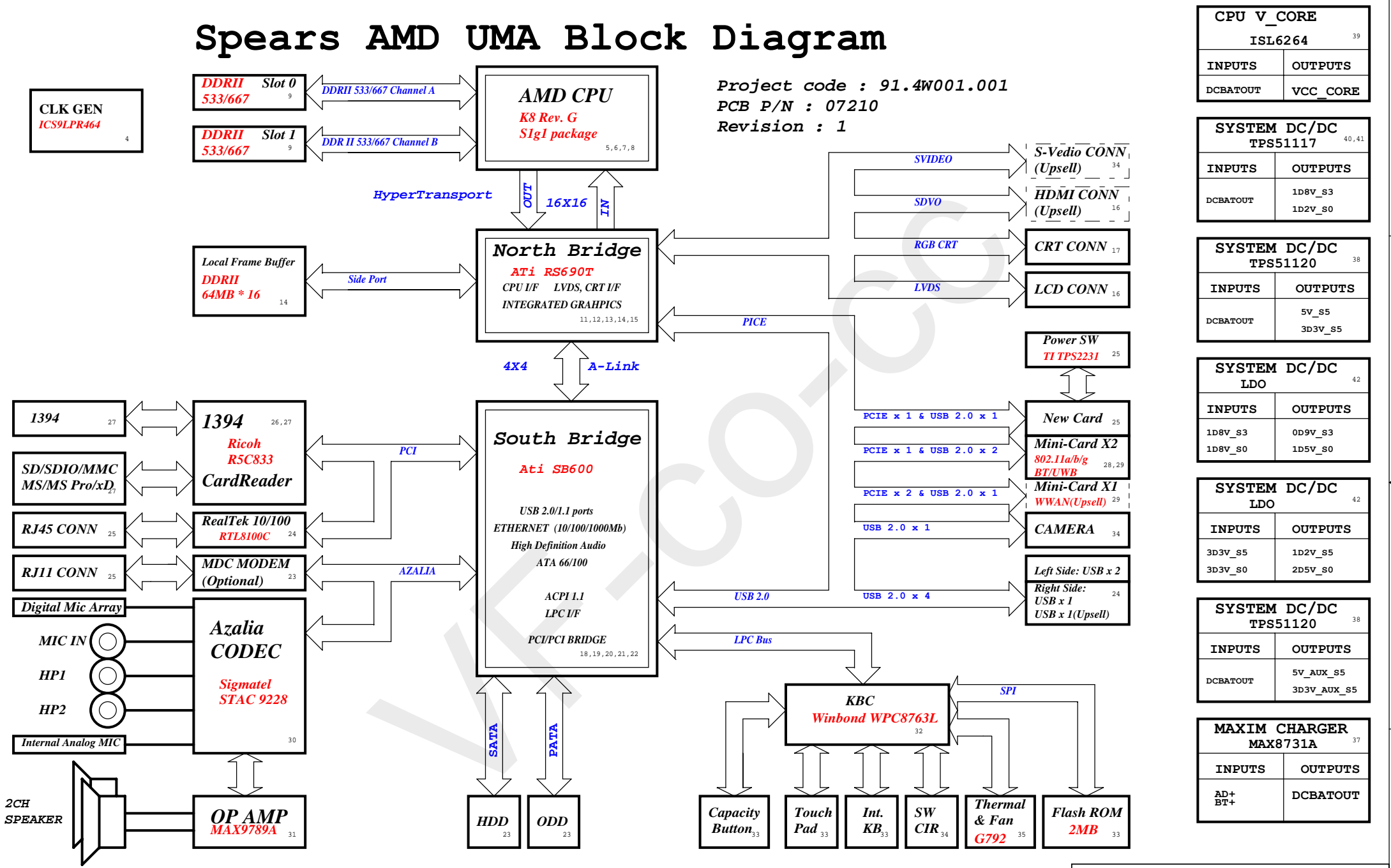

| CPU V_CORE | |
|------------|----------|
| ISL6264 39 | |
| INPUTS | OUTPUTS |
| DCBATOUT | VCC_CORE |

| SYSTEM DC/DC | |
|----------------|---------|
| TPS51117 40,41 | |
| INPUTS | OUTPUTS |
| DCBATOUT | 1D8V_S3 |
| | 1D2V_S0 |

| SYSTEM DC/DC | |
|--------------|---------|
| TPS51120 38 | |
| INPUTS | OUTPUTS |
| DCBATOUT | 5V_S5 |
| | 3D3V_S5 |

| SYSTEM DC/DC | |
|--------------|---------|
| LDO 42 | |
| INPUTS | OUTPUTS |
| 1D8V_S3 | 0D9V_S3 |
| 1D8V_S0 | 1D5V_S0 |

| SYSTEM DC/DC | |
|--------------|---------|
| LDO 42 | |
| INPUTS | OUTPUTS |
| 3D3V_S5 | 1D2V_S5 |
| 3D3V_S0 | 2D5V_S0 |

| SYSTEM DC/DC | |
|--------------|-------------|
| TPS51120 38 | |
| INPUTS | OUTPUTS |
| DCBATOUT | 5V_AUX_S5 |
| | 3D3V_AUX_S5 |

| MAXIM CHARGER | |
|---------------|----------|
| MAX8731A 37 | |
| INPUTS | OUTPUTS |
| AD+ BT+ | DCBATOUT |

緯創資通 Wistron Corporation
 21F, 88, Sec.1, Hsin Tai Wu Rd., Hsichih,
 Taipei Hsien 221, Taiwan, R.O.C.

Title: **System Block Diagram**

| | | |
|---------|-----------------|----------|
| Size A3 | Document Number | Rev |
| | DS2-AMD | 1 |

Date: Monday, September 24, 2007 Sheet 1 of 44

CPU_CORE
ISL6264CRZ

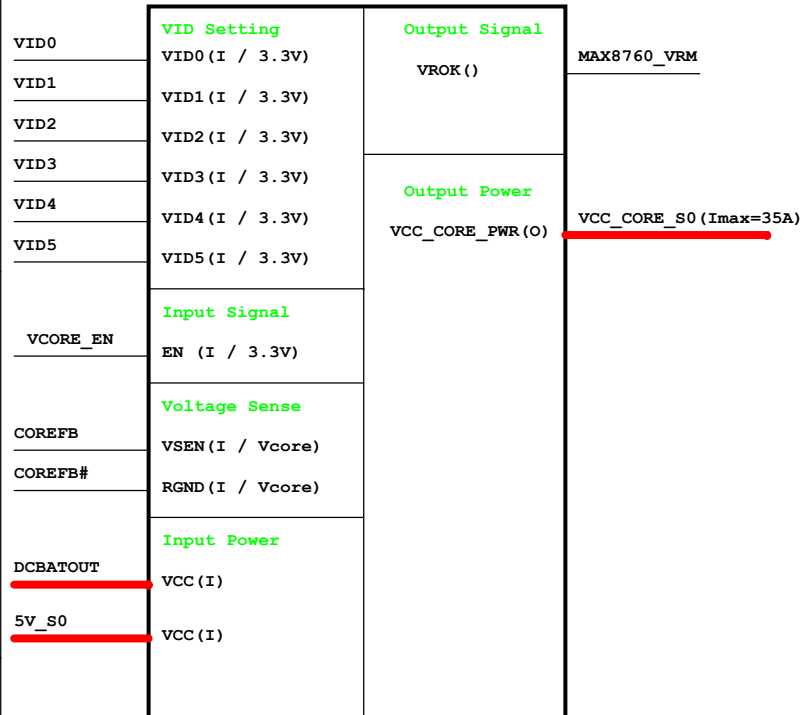

3D3V/5V
TI TPS51120

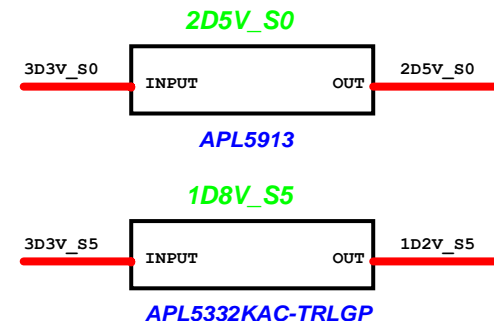
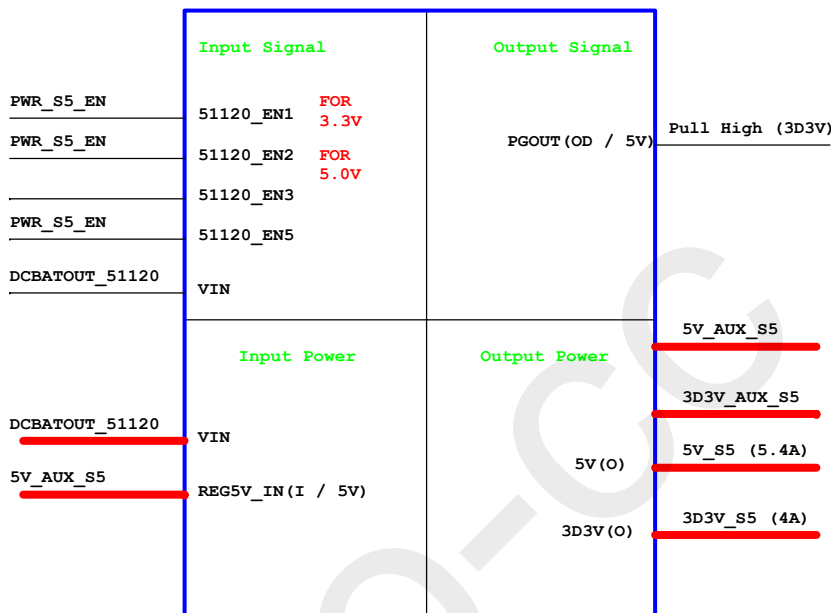

TI TPS51117
1.8V

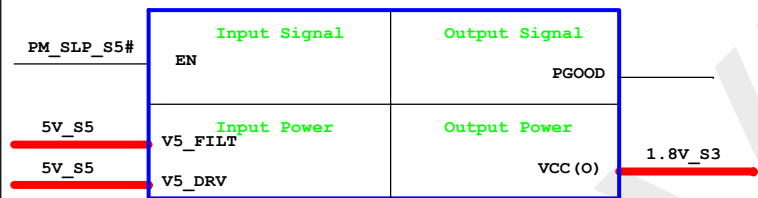

Adapter

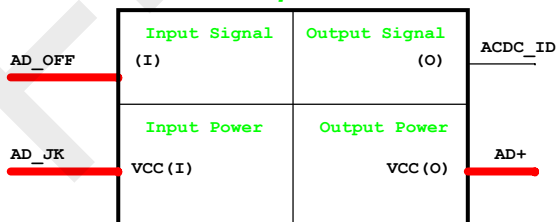

Charger_MAX8731AETI

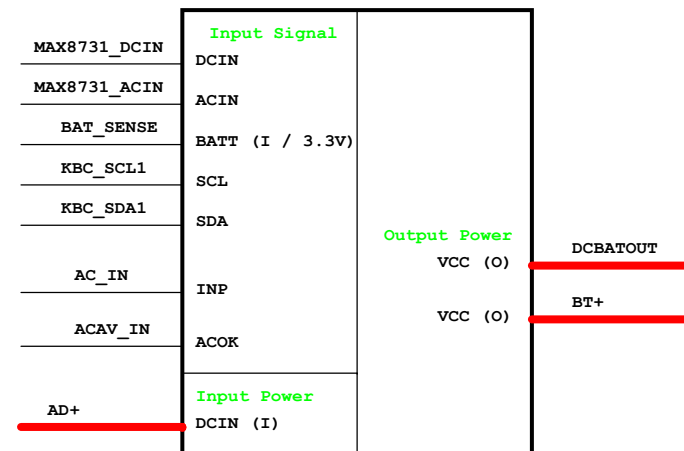

TI TPS51117
1.2V

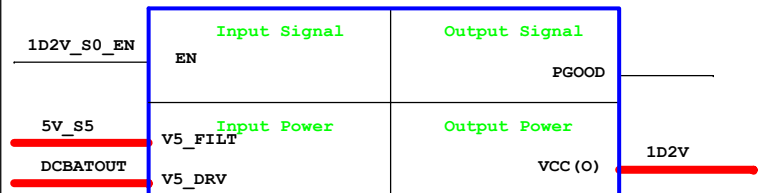

緯創資通 Wistron Corporation
21F, 88, Sec.1, Hsin Tai Wu Rd., Hsichih, Taipei Hsien 221, Taiwan, R.O.C.

VF-CO-CC

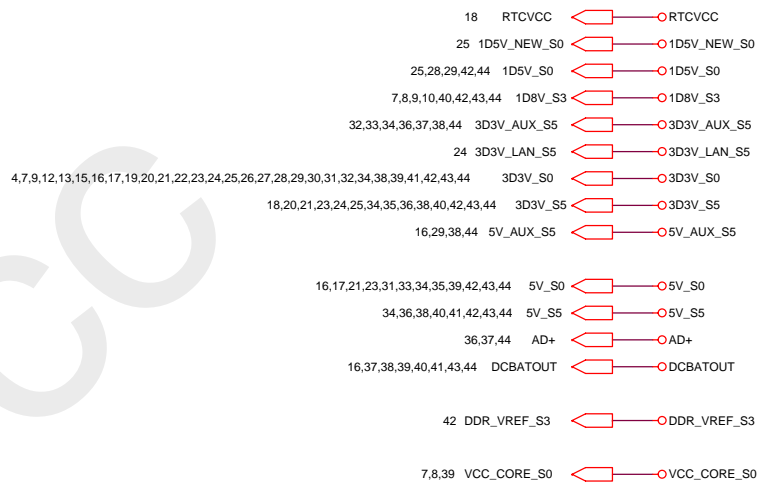

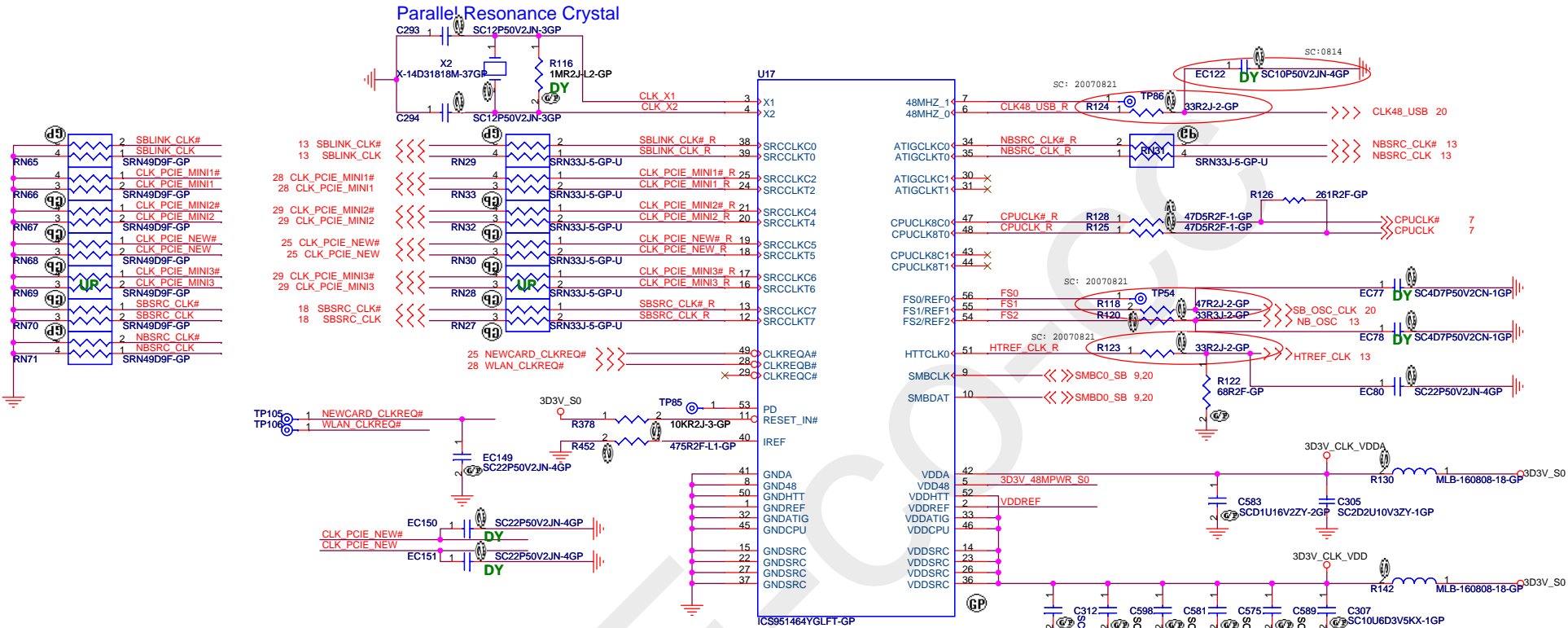

| | RN27 ~RN33 | R452 | RN65 ~RN71 | R125 R128 | R126 |
|-------------------------------|---------------|--------|---------------|--------------|--------|
| SILEGO xSLG84607 | 330ohm | 475Ohm | 49.90ohm | 00hm | DY |
| REALTEK RTM870T-691 | 00hm | DY | DY | 47.50hm | 2610hm |
| ICS 9LPR464 | 330hm | DY | DY | 330hm | DY |
| SpectralLinear SL28RS680-3 | 00hm | DY | DY | 00hm | DY |

EXT CLK FREQUENCY SELECT TABLE(MHZ)

| FS2 | FS1 | FS0 | CPU | SRCCLK [2:1] | HTT | USB | REF0 REF1 REF2 |
|-----|-----|-----|--------|-----------------|-------|-------|----------------------|
| 0 | 0 | 0 | Hi-Z | 100.00 | Hi-Z | 48.00 | 14.318 |
| 0 | 0 | 1 | X/2 | 100.00 | X/3 | 48.00 | 14.318 |
| 0 | 1 | 0 | 230.00 | 100.00 | 76.67 | 48.00 | 14.318 |
| 0 | 1 | 1 | 240.00 | 100.00 | 80.00 | 48.00 | 14.318 |
| 1 | 0 | 0 | 100.00 | 100.00 | 66.66 | 48.00 | 14.318 |
| 1 | 0 | 1 | 133.33 | 100.00 | 66.66 | 48.00 | 14.318 |
| 1 | 1 | 0 | 166.67 | 100.00 | 66.66 | 48.00 | 14.318 |
| 1 | 1 | 1 | 200.00 | 100.00 | 66.67 | 48.00 | 14.318 |

<Variant Name>

緯創資通 Wistron Corporation
21F, 88, Sec.1, Hsin Tai Wu Rd., Hsichih,
Taipei Hsien 221, Taiwan, R.O.C.

Title
Clock generator ICS9LPR464

Size A3 Document Number **DS2-AMD** Rev **1**

Date: Monday, September 24, 2007 Sheet 4 of 44

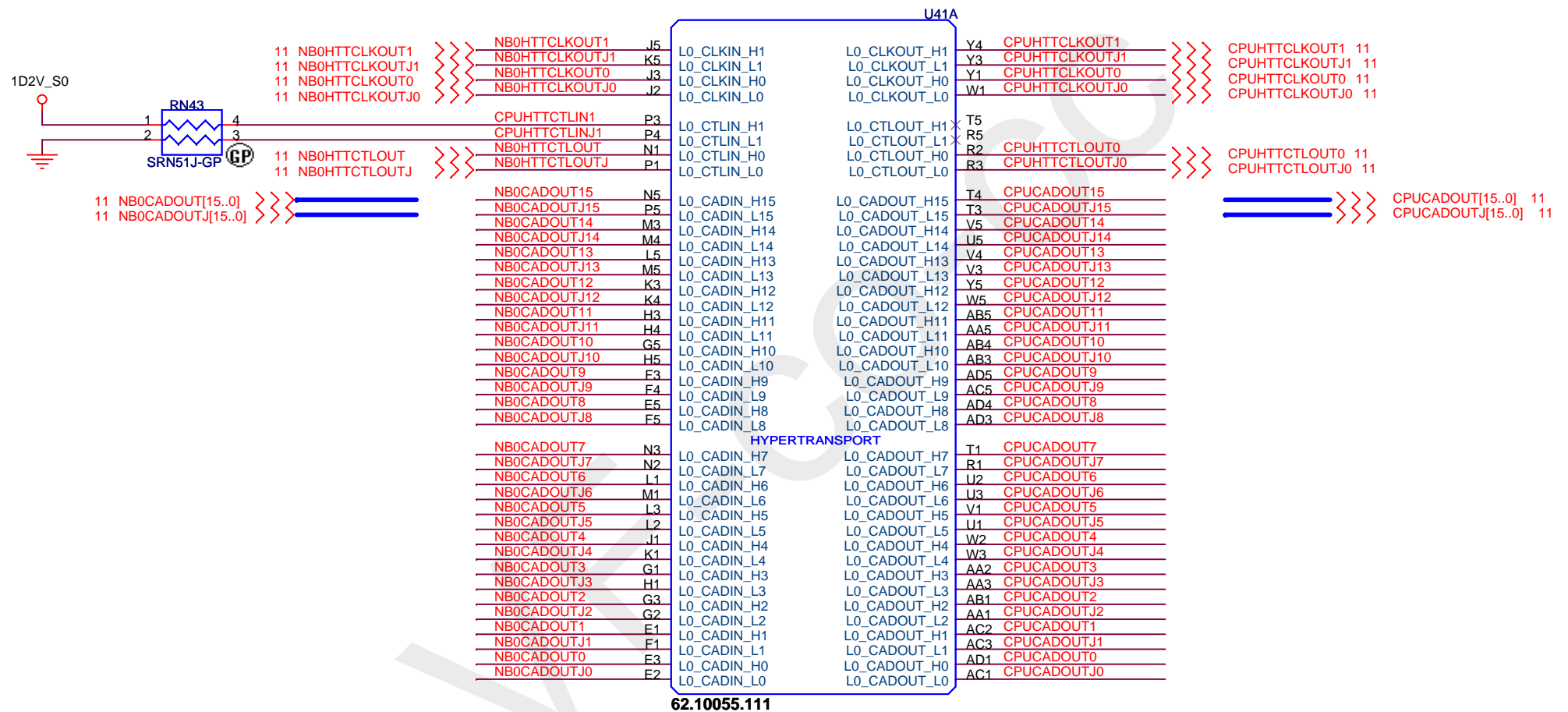

緯創資通 **Wistron Corporation**
 21F, 88, Sec.1, Hsin Tai Wu Rd., Hsichih,
 Taipei Hsien 221, Taiwan, R.O.C.

Title **AMD K8 CPU Rev.G**

Size A4 Document Number **DS2-AMD** Rev **1**

Date: Monday, September 24, 2007 Sheet 5 of 44

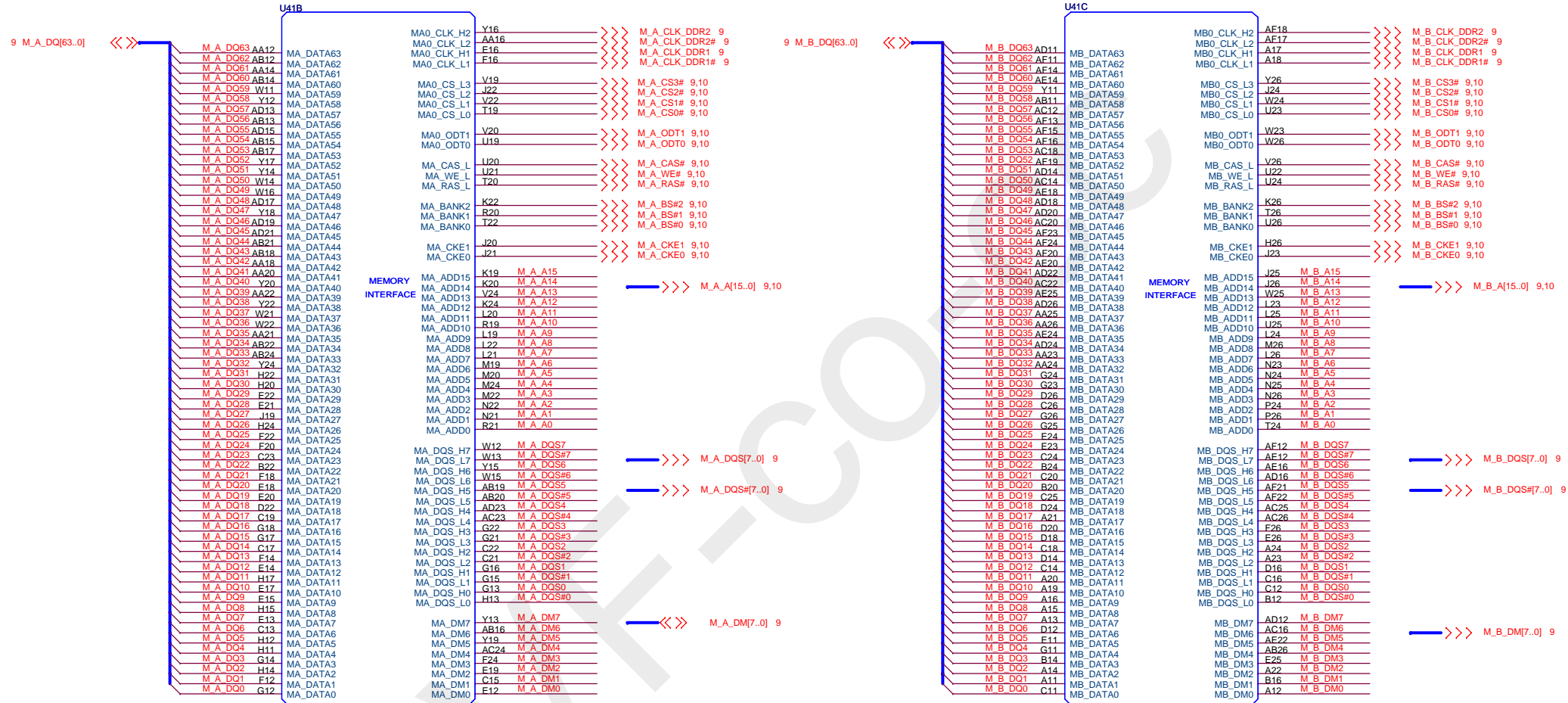

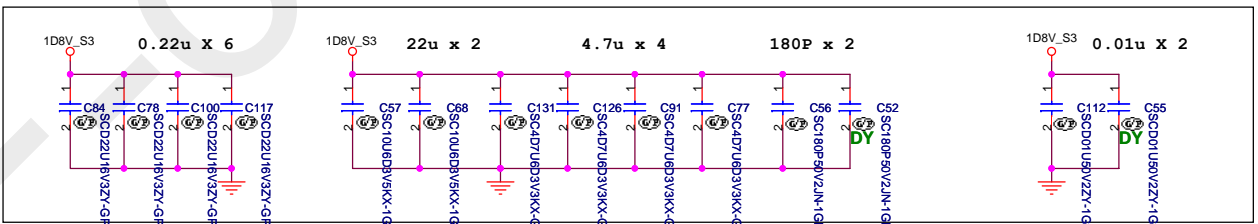
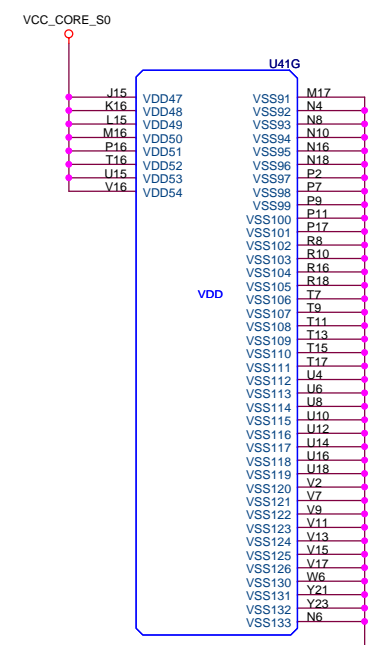
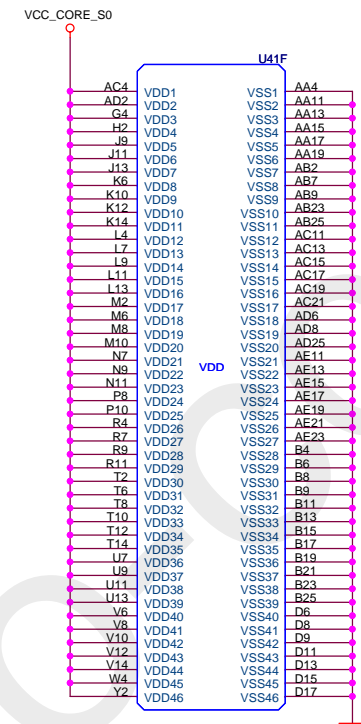
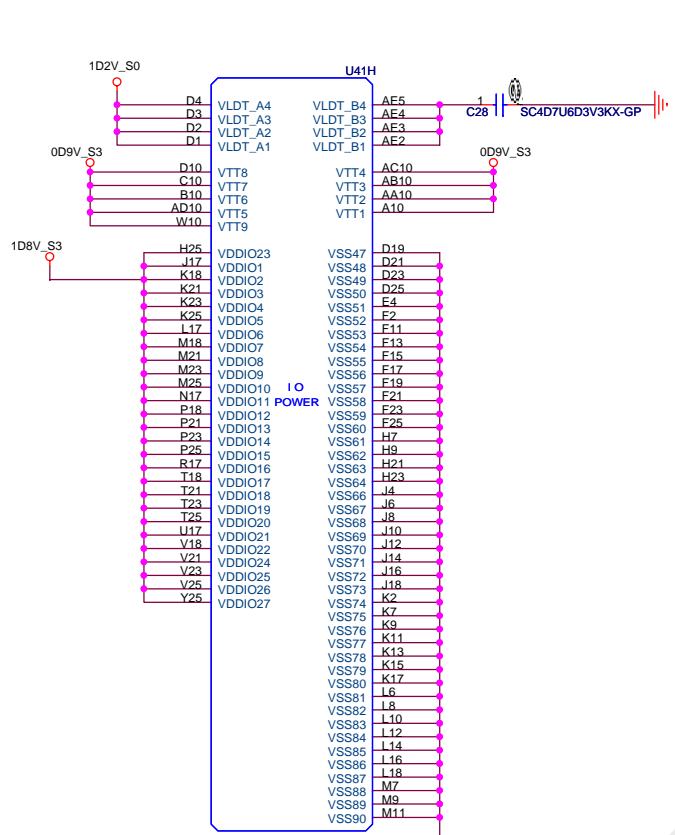

Place near to CPU

LAYOUT: Place on backside of processor.

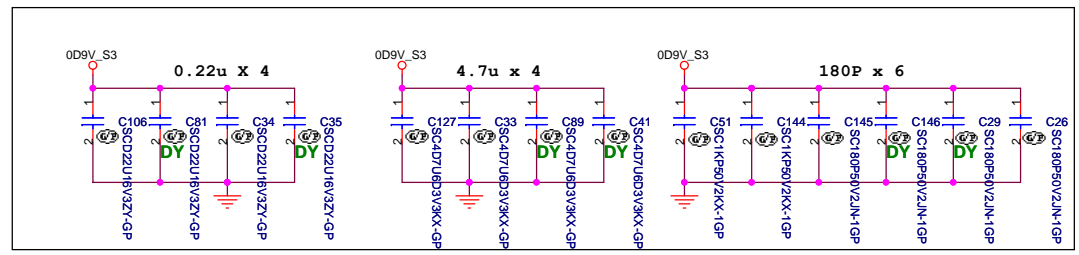
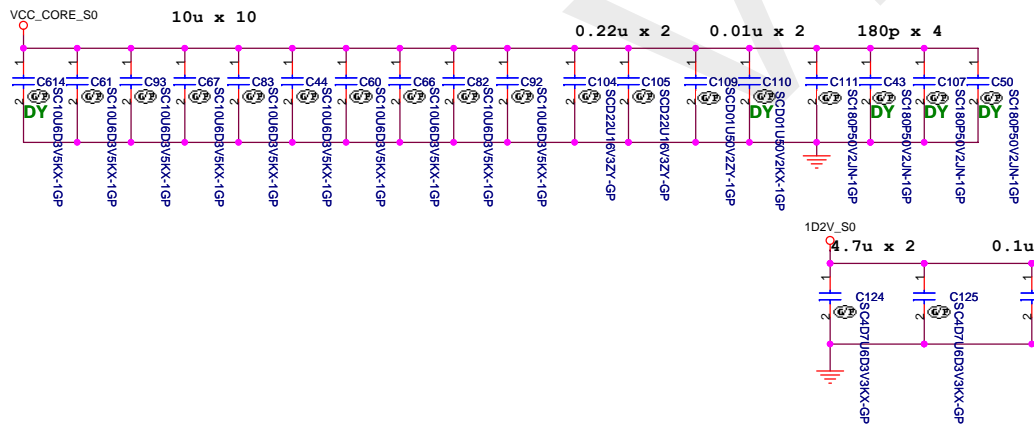

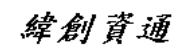

Wistron Corporation
 21F, 88, Sec.1, Hsin Tai Wu Rd., Hsichih,
 Taipei Hsien 221, Taiwan, R.O.C.

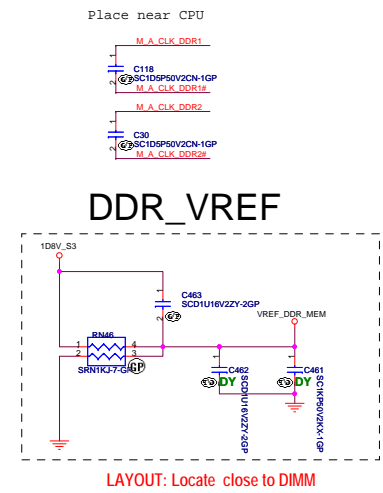
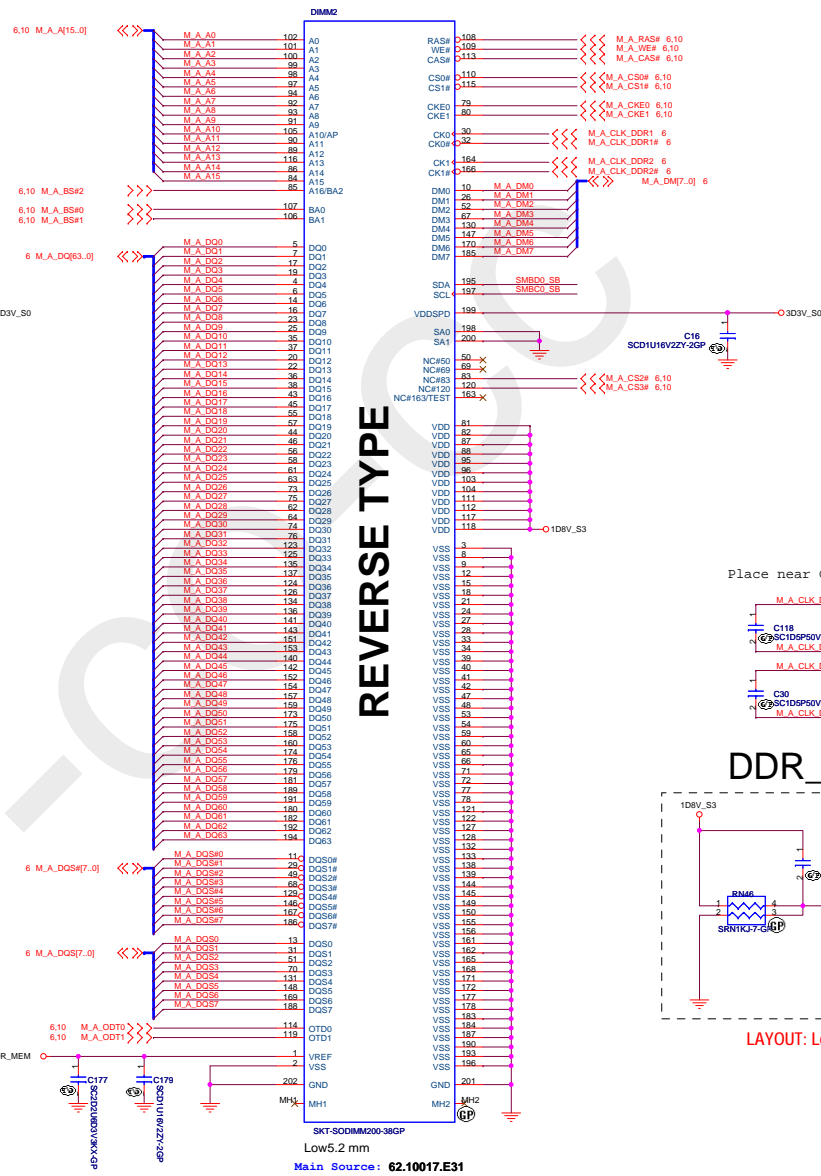
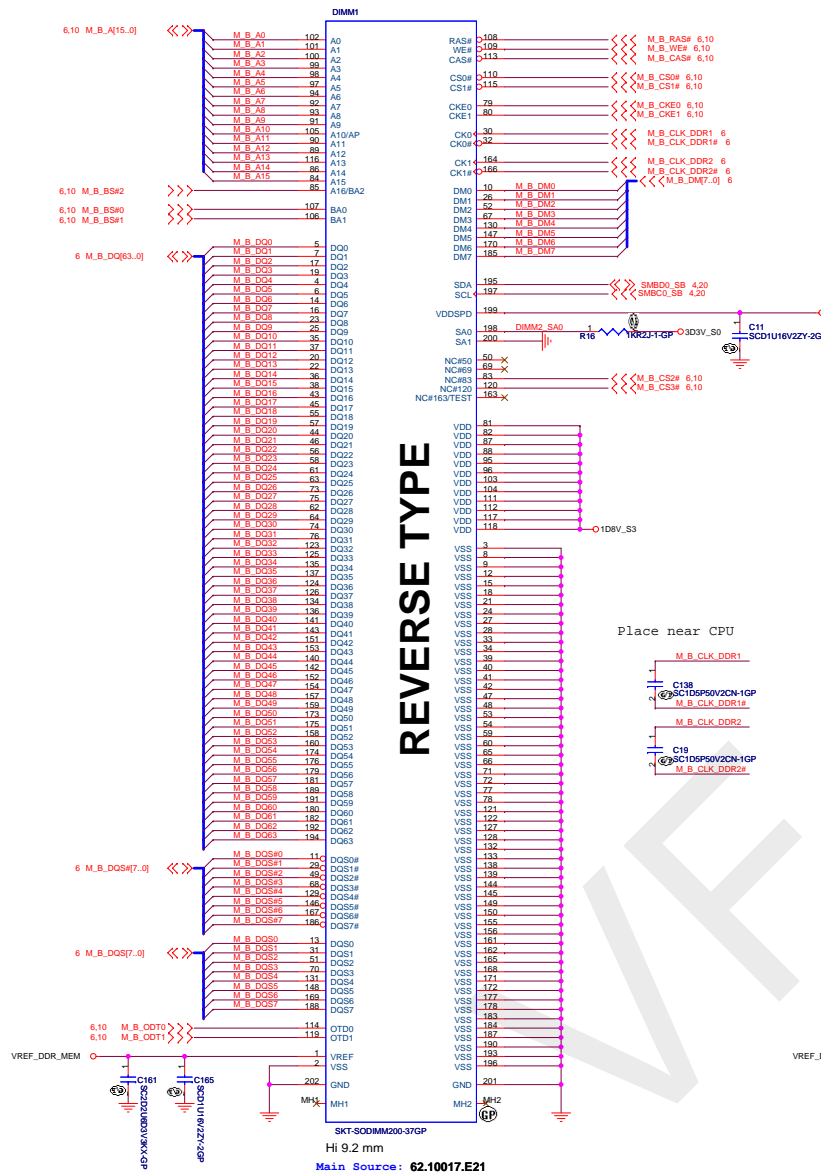
| | | |
|----------------------------------|-----------------|----------|
| Title | | |
| AMD K8 CPU Rev.G | | |
| Size | Document Number | Rev |
| A3 | DS2-AMD | 1 |
| Date: Monday, September 24, 2007 | | |
| Sheet 8 of 44 | | |

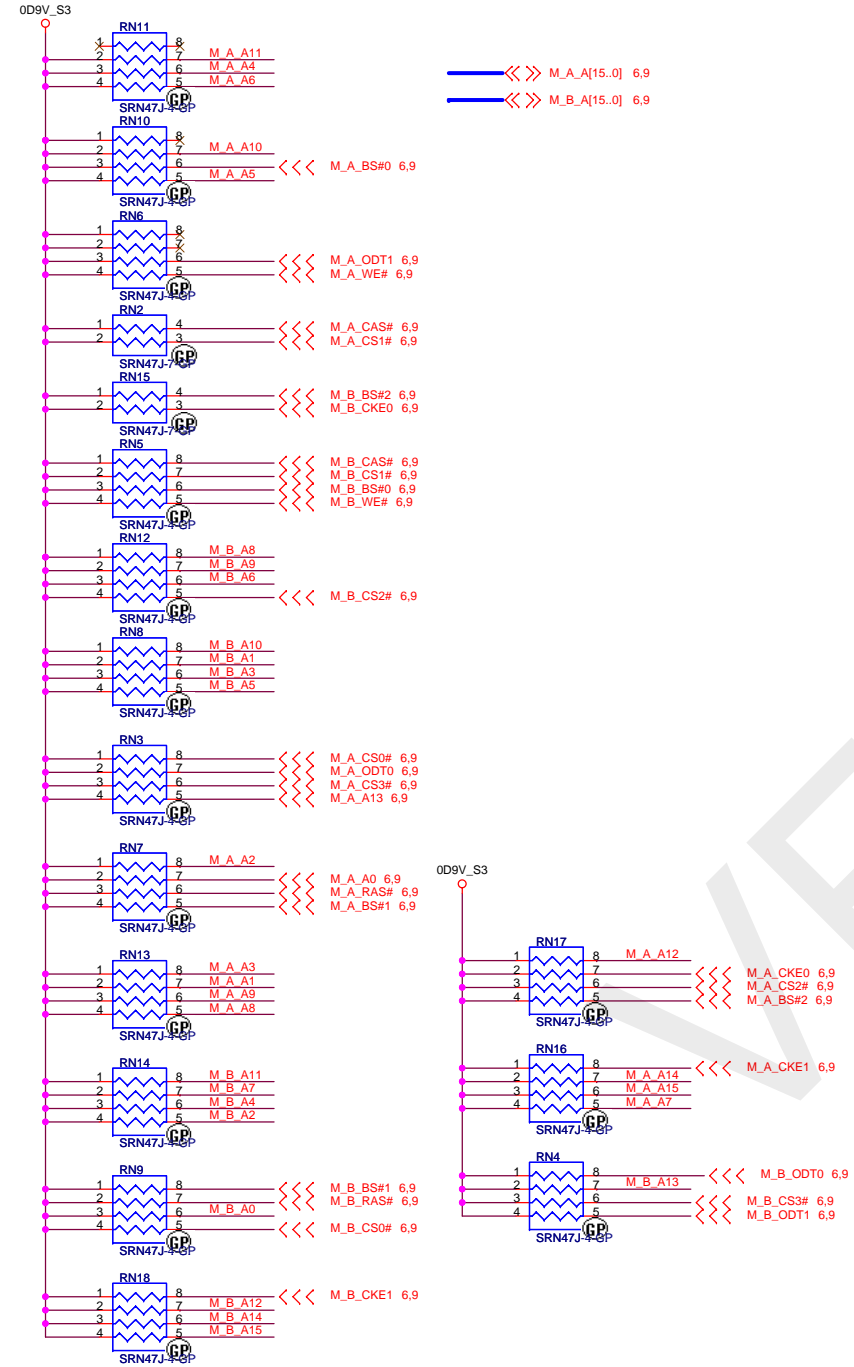

PARALLEL TERMINATION

Put decap near power(0.9V) and pull-up resistor



Decoupling Capacitor

Put decap near power(0.9V) and pull-up resistor

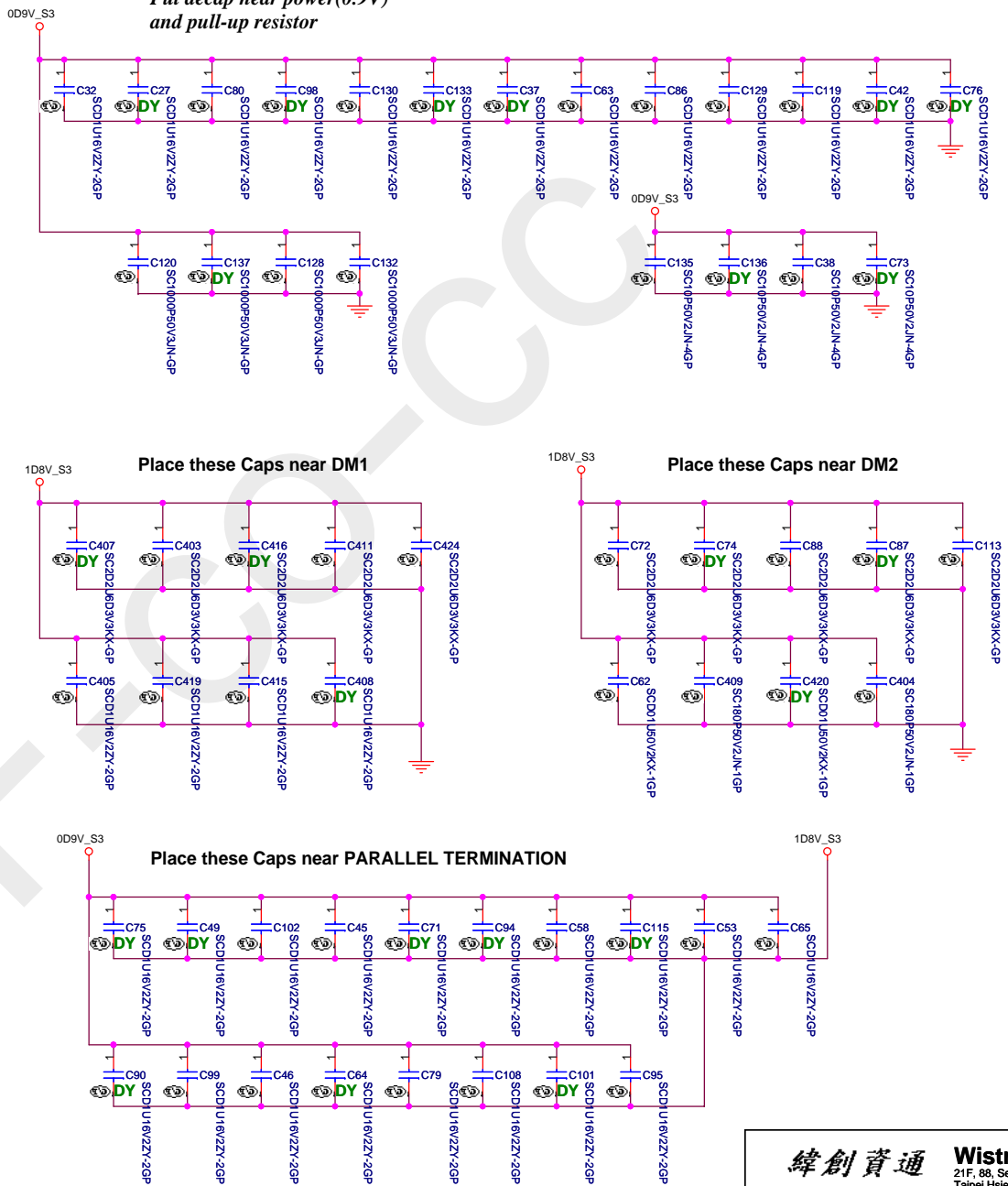

緯創資通 Wistron Corporation
21F, 88, Sec.1, Hsin Tai Wu Rd., Hsichih, Taipei Hsien 221, Taiwan, R.O.C.

Title: **DDR DAMPING & TERMINATION**

Size: A3 Document Number: **DS2-AMD** Rev: 1

Date: Monday, September 24, 2007 Sheet 10 of 44



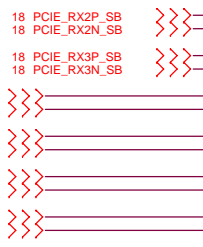
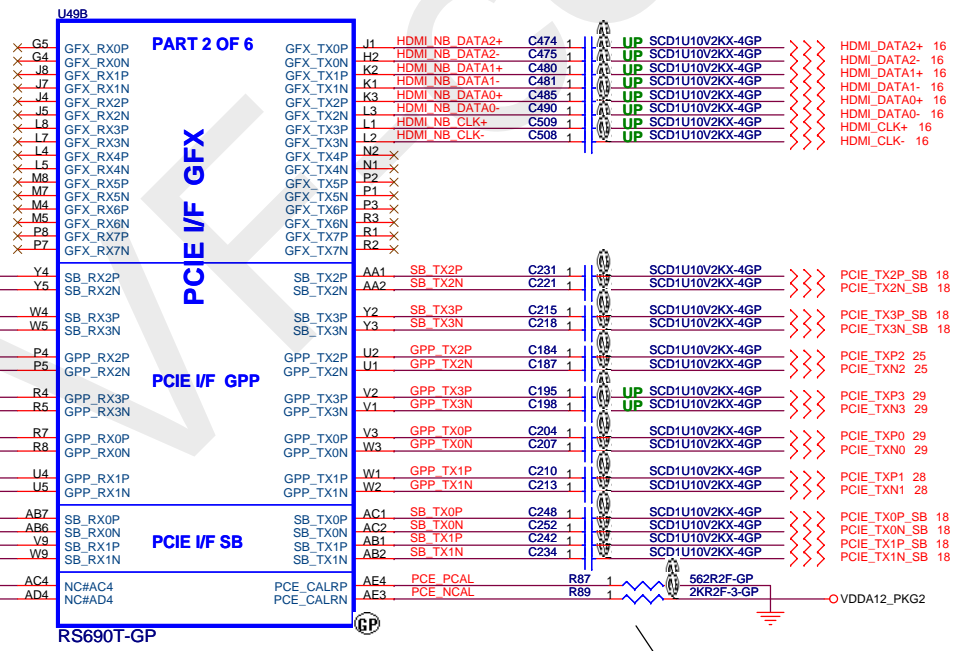
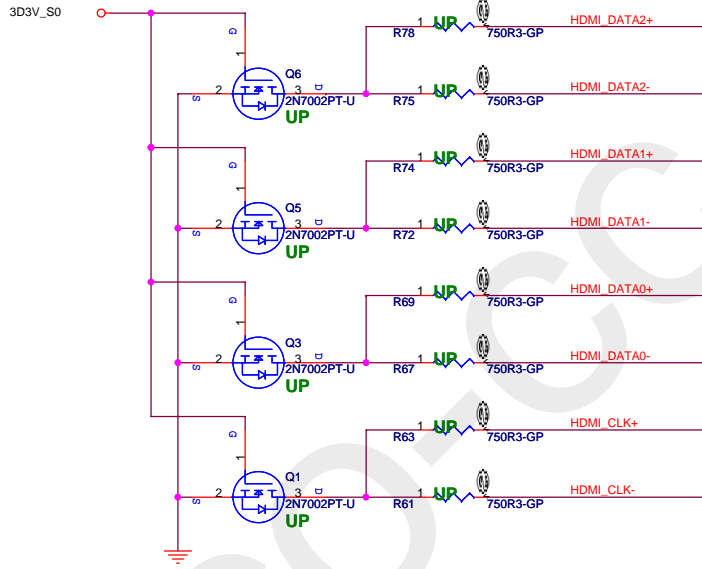

A-LINK

EXPRESS CARD
 MINICARD 3
 MINICARD 2
 MINICARD 1

close to NB ball

緯創資通 Wistron Corporation
 21F, 88, Sec.1, Hsin Tai Wu Rd., Hsichih, Taipei Hsien 221, Taiwan, R.O.C.

Title: **North Bridge - AtI RS690T**

Size A3 Document Number **DS2-AMD** Rev **1**

Date: Monday, September 24, 2007 Sheet 12 of 44

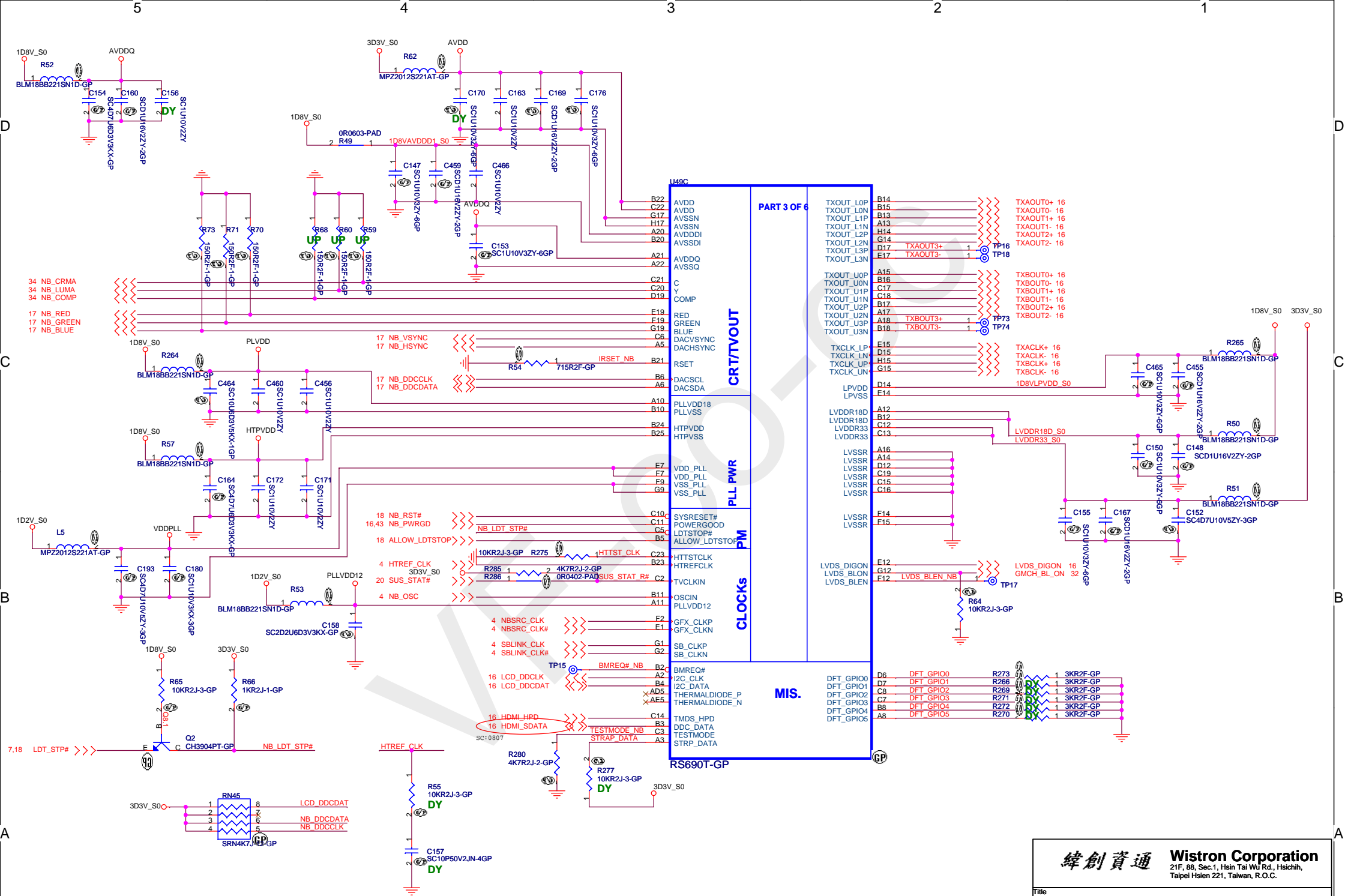

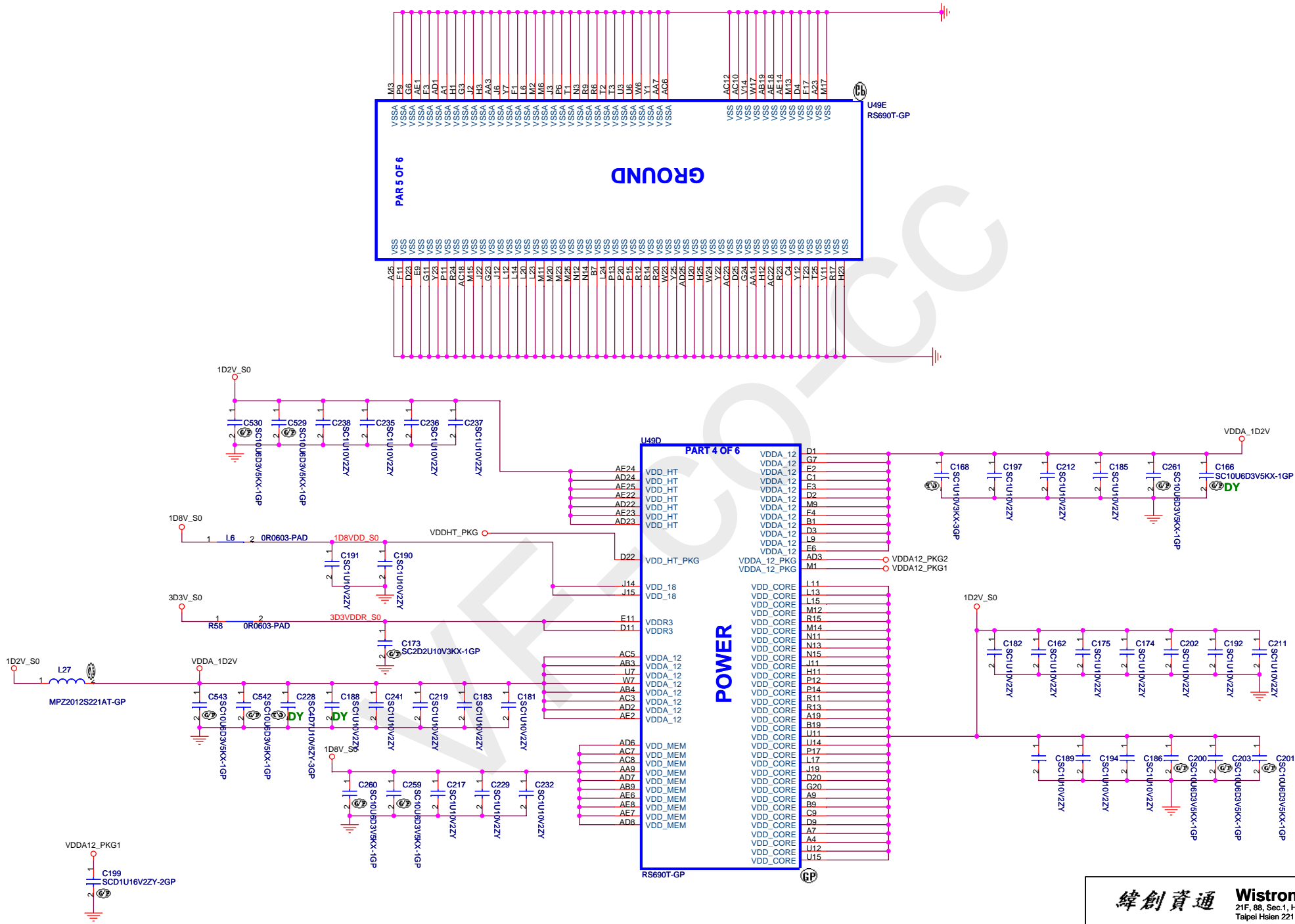

緯創資通 **Wistron Corporation**
 21F, 88, Sec.1, Hsin Tai Wu Rd., Hsichih,
 Taipei Hsien 221, Taiwan, R.O.C.

Title: **North Bridge - ATi RS690T**

Size A3 Document Number **DS2-AMD** Rev **1**

Date: Monday, September 24, 2007 Sheet 15 of 44

HDMI CONNECTOR

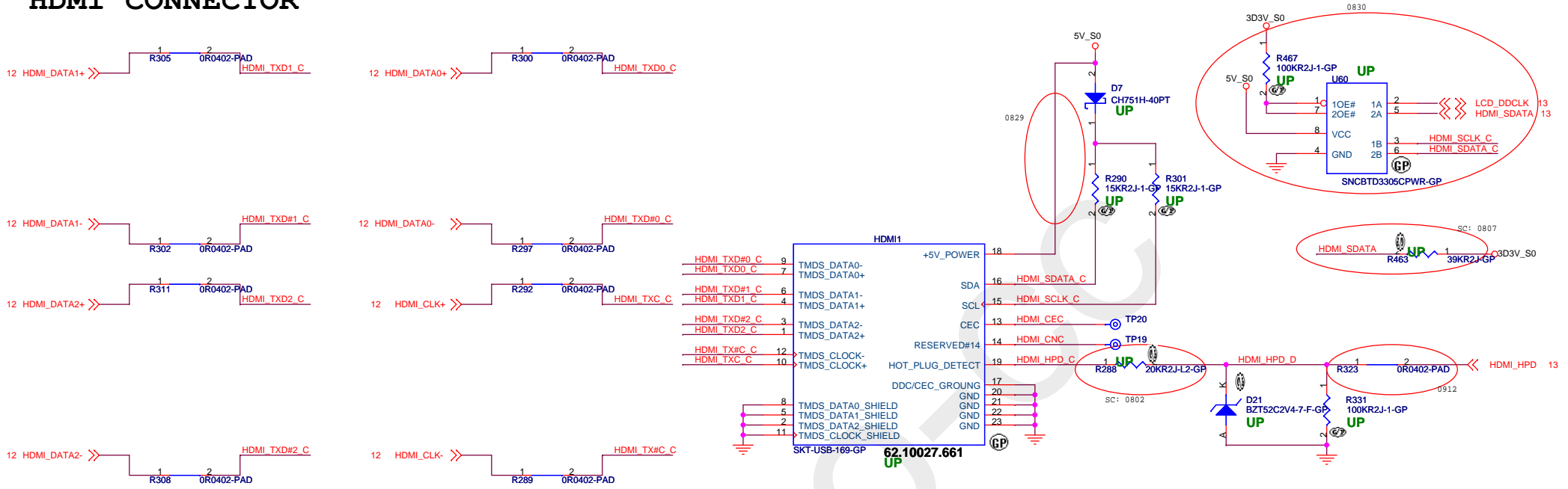

LCD CONNECTOR

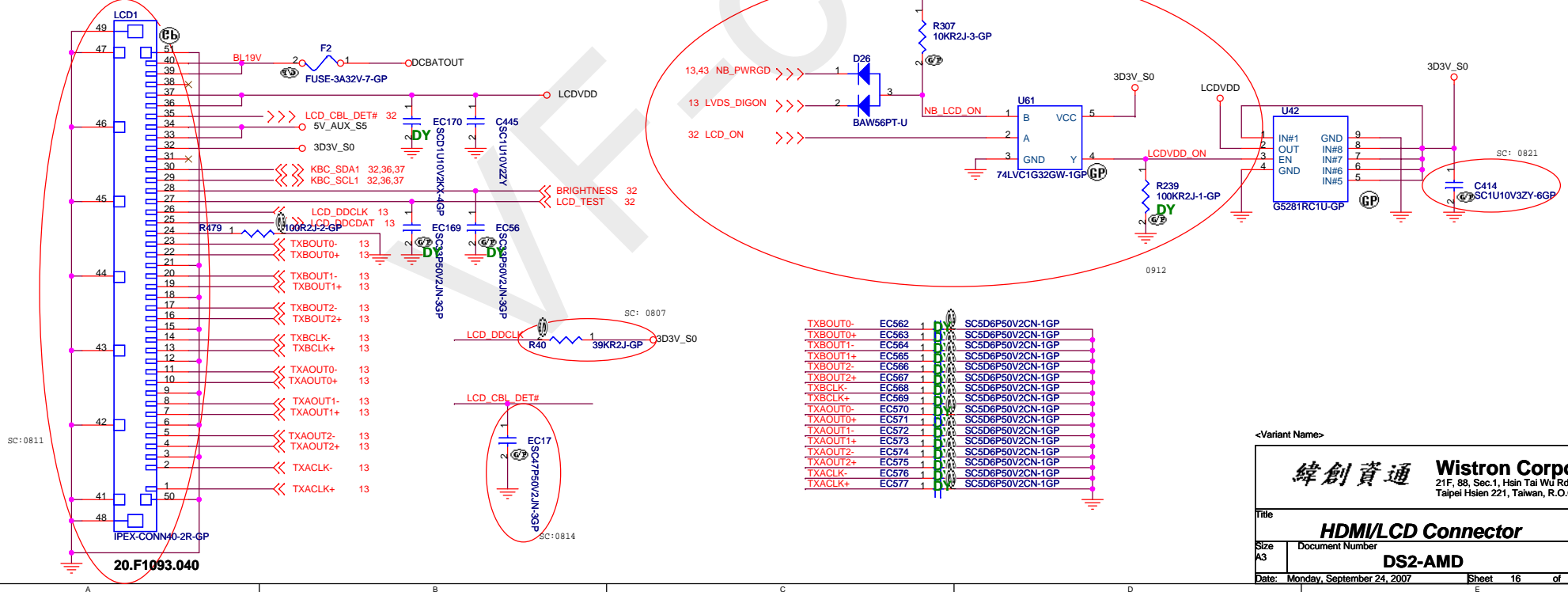

Wistron Corporation
21F, 88, Sec.1, Hsin Tai Wu Rd., Hsichih, Taipei Hsien 221, Taiwan, R.O.C.

Document Number: **DS2-AMD**

Rev: **1**

Date: Monday, September 24, 2007

CRT I/F & CONNECTOR

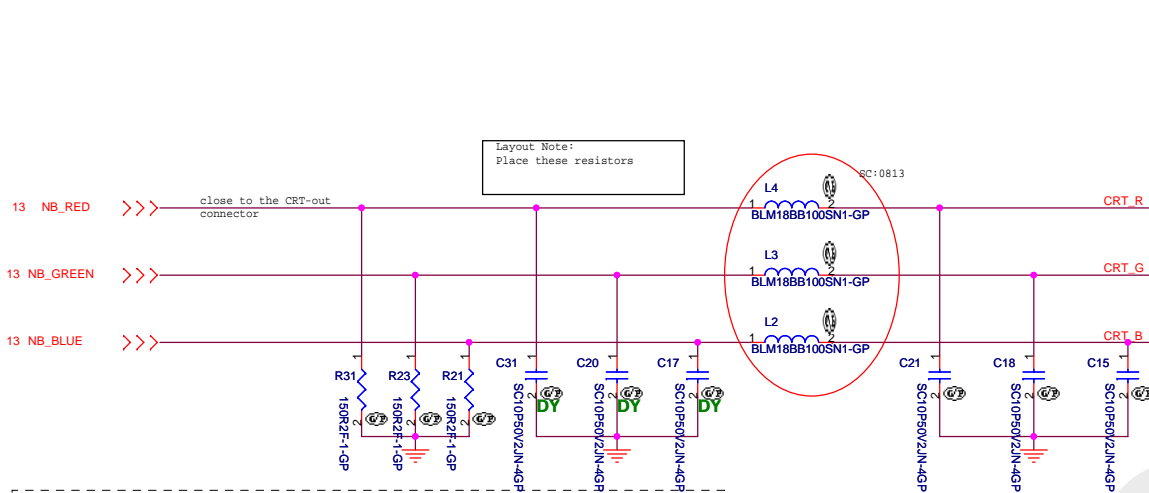

Layout Note:
 * Must be a ground return path between this ground and the ground on the VGA connector.
 Pi-filter & 150 Ohm pull-down resistors should be as close as to CRT CONN. RGB will hit 75 Ohm first, pi-filter, then CRT CONN.

Hsync & Vsync level shift

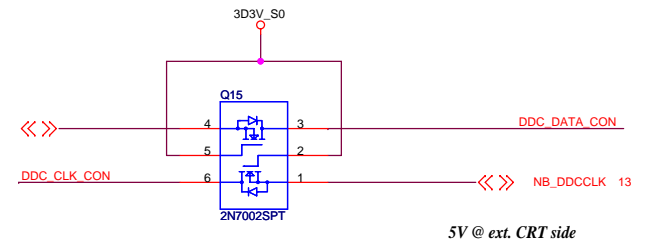
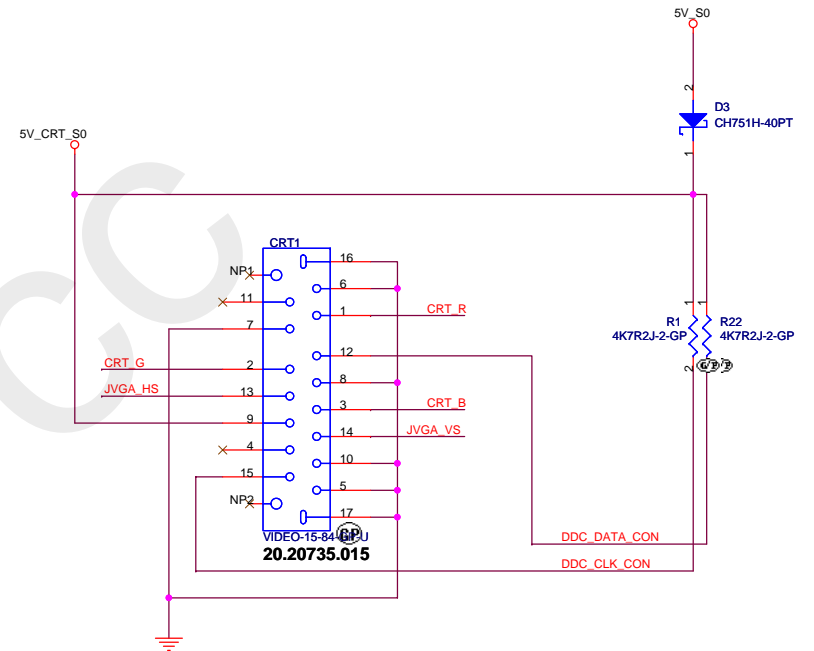
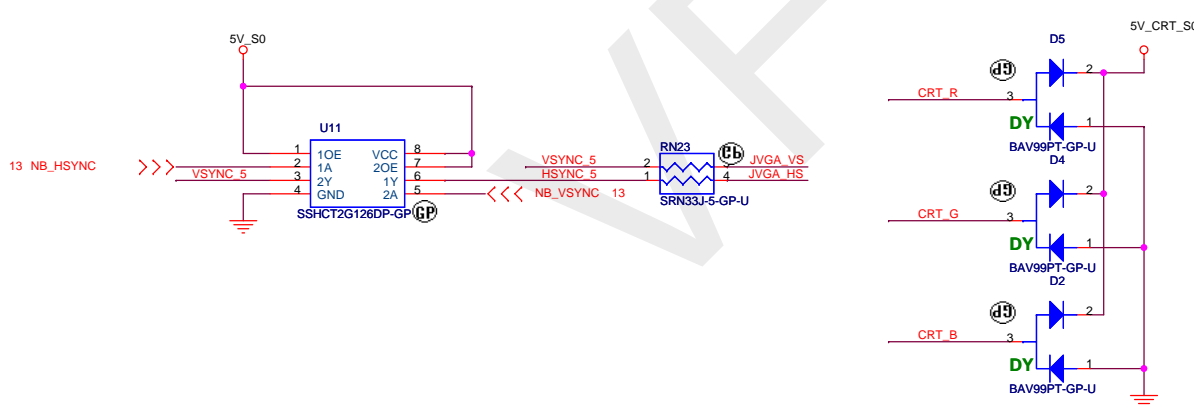

PLACE SATA AC DECOUPLING CAPS CLOSE TO SB600

23 SATA_TXP
23 SATA_TXN
23 SATA_RXN_SB
23 SATA_RXP_SB

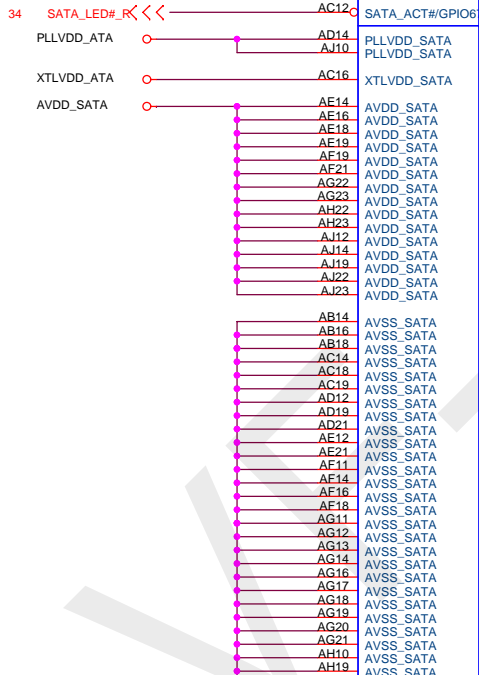
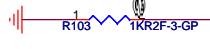
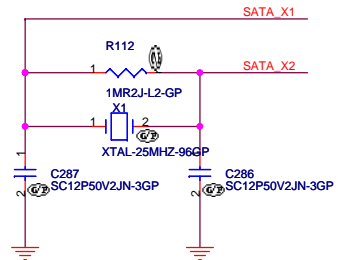

SB600-GP 71.SB600.00U

U3B 2 of 4

SERIAL ATA

SERIAL ATA POWER

SPI ROM

HW MONITOR

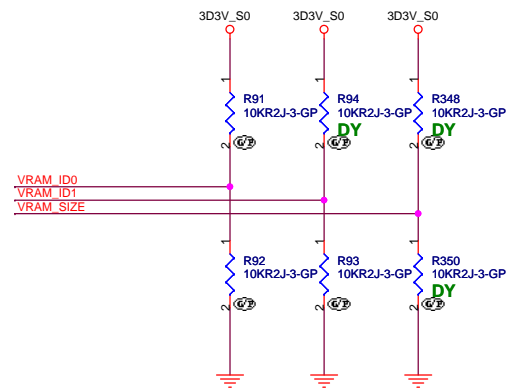
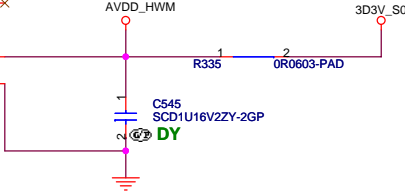
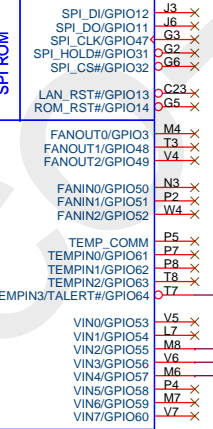

| | GPIO56 | GPIO55 |
|---------|--------|--------|
| | ID1 | ID0 |
| HYNIX | 0 | 0 |
| QIMONDA | 0 | 1 |

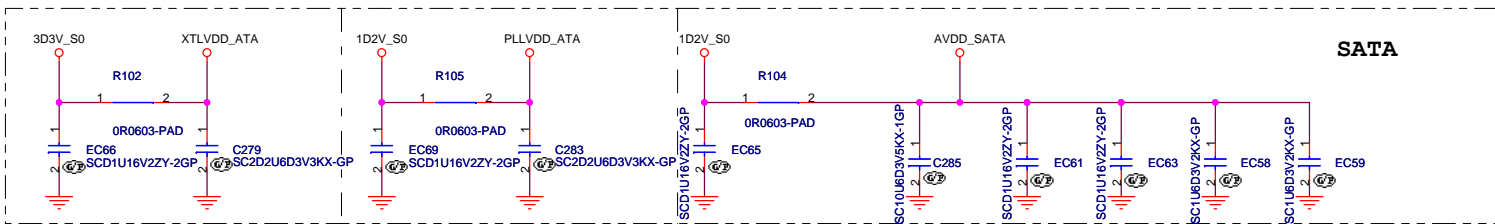

緯創資通 Wistron Corporation
21F, 88, Sec.1, Hsin Tai Wu Rd., Hsichih, Taipei Hsien 221, Taiwan, R.O.C.

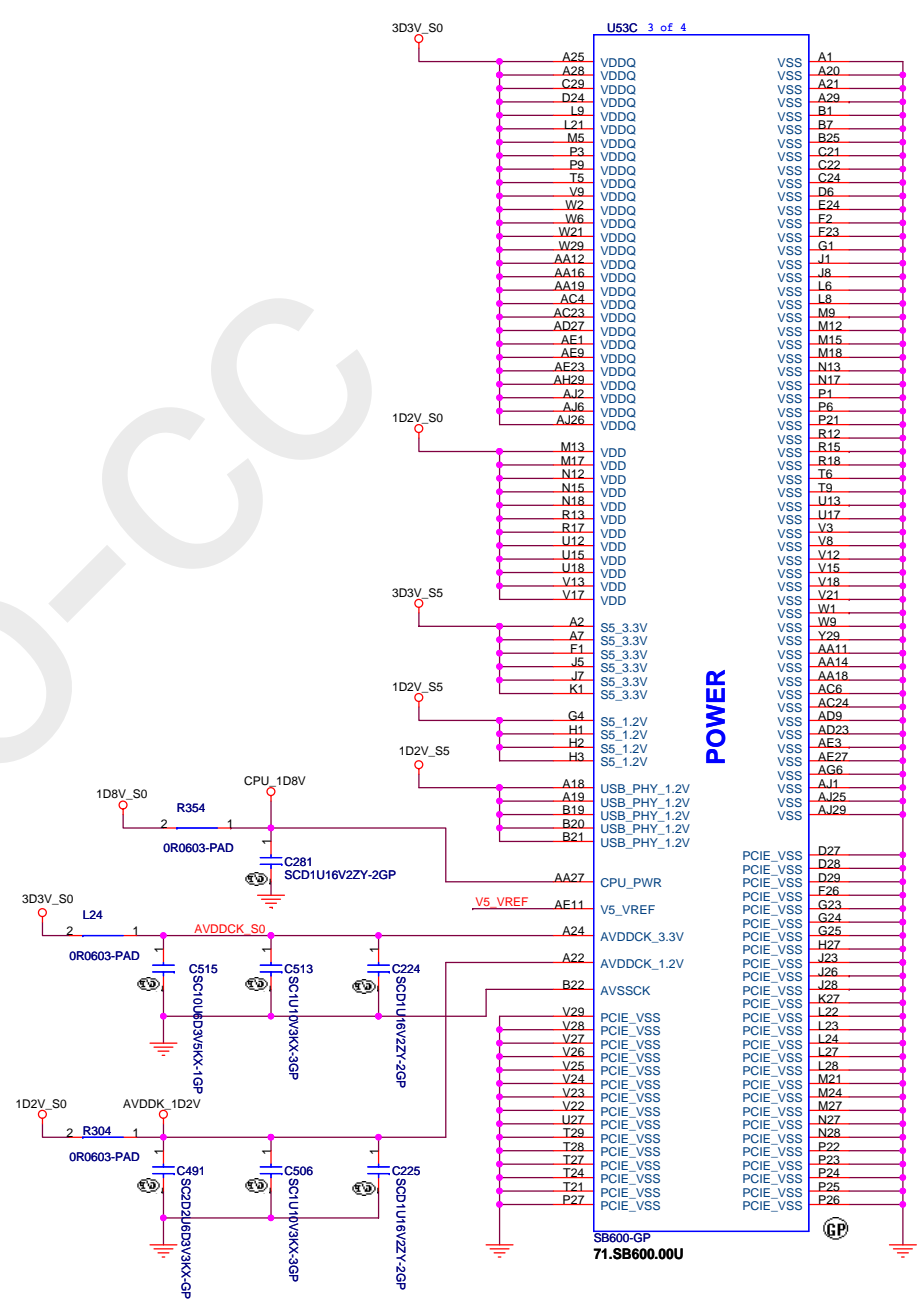
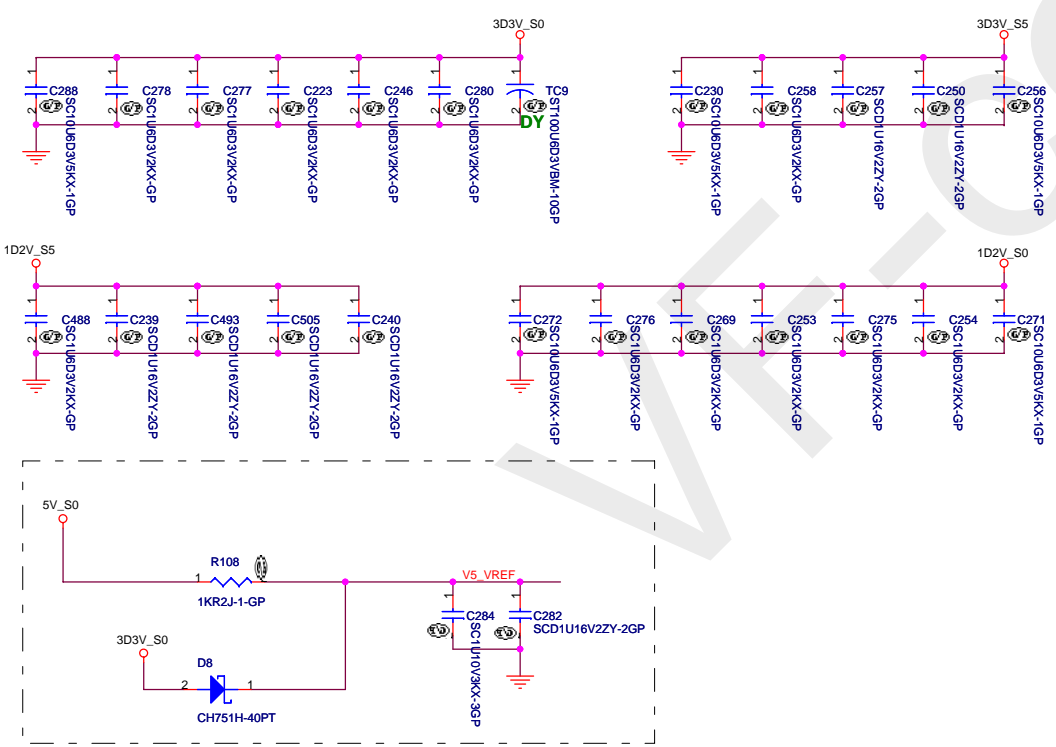

緯創資通 Wistron Corporation
21F, 88, Sec. 1, Hsin Tai Wu Rd., Hsichih, Taipei Hsien 221, Taiwan, R.O.C.

Title: **South Bridge - ATi SB600**

| | | |
|---------|--------------------------------|--------------|
| Size A3 | Document Number DS2-AMD | Rev 1 |
|---------|--------------------------------|--------------|

Date: Monday, September 24, 2007 Sheet 21 of 44

PCI_CLK4
 PCI_CLK6
 PCI_CLK0
 PCI_CLK1

20 AC_SDATAOUT
 18,32 PCLK_KBC
 18 PCI_CLK6
 18,24 PCLK_LAN
 18,26 PCLK_PCM

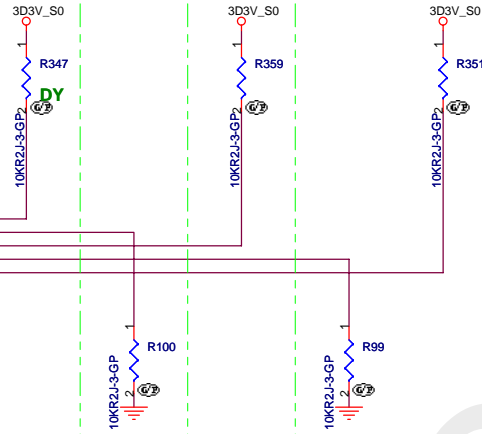

REQUIRED SYSTEM STRAPS

| SB600 | | | | | |
|-----------|--------------------------------|---------------------------|----------------------|---|----------|
| | AC_SDOUT | PCI_CLK4 | PCI_CLK6 | PCI_CLK0 | PCI_CLK1 |
| PULL HIGH | USE DEBUG STRAPS | USE INT. PLL48 | CPU IF=K8 DEFAULT | ROM TYPE: H, H = PCI ROM H, L = SPI ROM L, H = LPC ROM | DEFAULT |
| PULL LOW | IGNORE DEBUG STRAPS DEFAULT | USE EXT. 48MHZ DEFAULT | CPU IF=P4 | L, L = FWH ROM | |

SB600 HAS 15K INTERNAL PU FOR PCI_AD[23..28]

DEBUG STRAPS

| | PCI_AD31 | PCI_AD30 | PCI_AD29 | PCI_AD28 | PCI_AD27 | PCI_AD26 | PCI_AD25 | PCI_AD24 | PCI_AD23 |
|------------|----------|----------|----------|---------------------------|------------------------|--------------------------|------------------------|------------------------------------|------------------------------------|
| STRAP HIGH | RESERVED | RESERVED | RESERVED | USE LONG RESET DEFAULT | USE PCI PLL DEFAULT | USE ACPI BCLK DEFAULT | USE IDE PLL DEFAULT | USE DEFAULT PCIE STRAPS DEFAULT | BOOT FAIL TIMER DISABLE DEFAULT |
| STRAP LOW | | | | USE SHORT RESET | BYPASS PCI PLL | BYPASS ACPI BCLK | BYPASS IDE PLL | USE EEPROM PCIE STRAPS | BOOT FAIL TIMER ENABLE |

SATA HD Connector

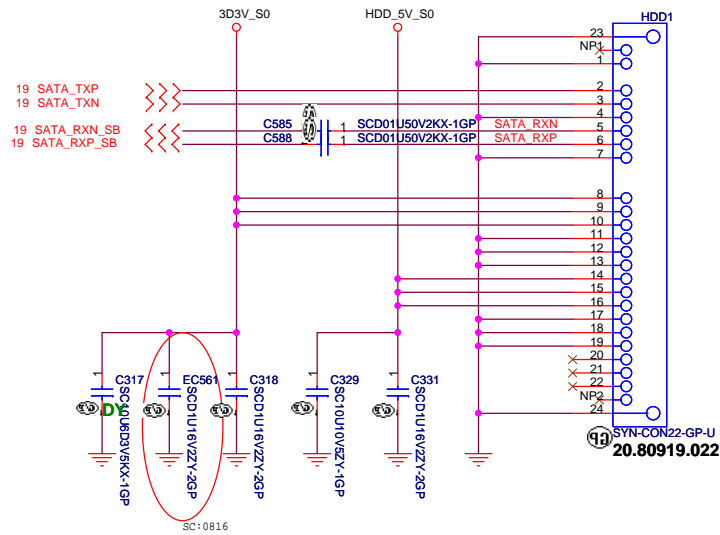

CD-ROM Connector

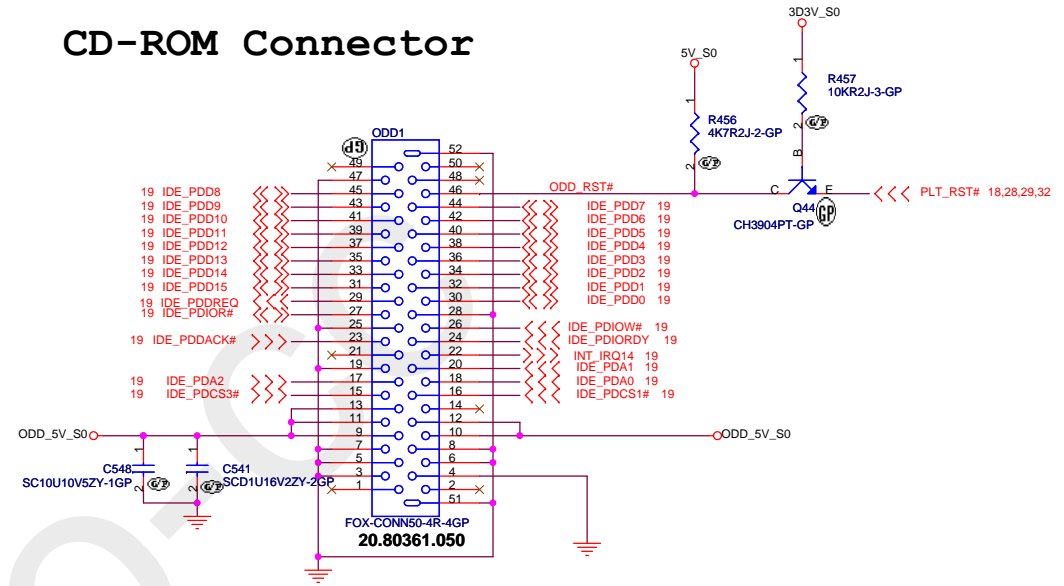

MDC 1.5 Connector

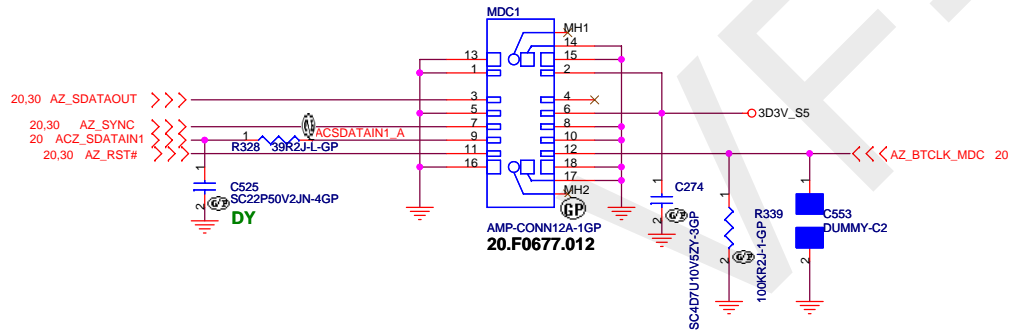

BT Module Connector

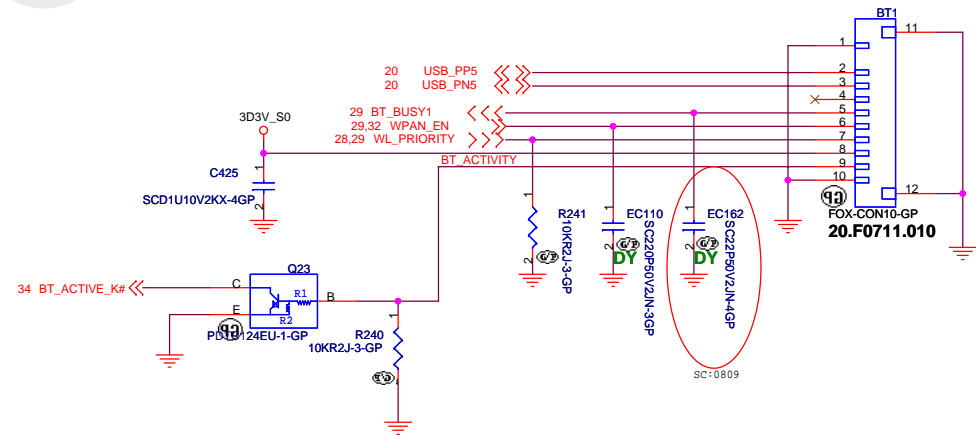

18,26 PCI_PAR
 18,26 PCI_TRDY#
 18,26 PCI_IRDY#
 18 INT_PIRQE#
 18 PCI_REQ1#
 18 PCI_GNT1#
 18,26 PCI_FRAME#
 18,26 PCI_DEVSEL#
 18,22 PCLK_LAN

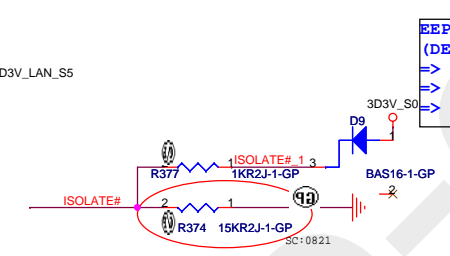
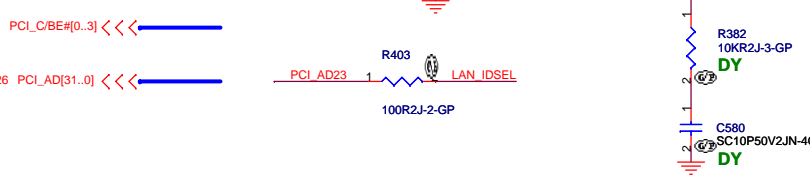
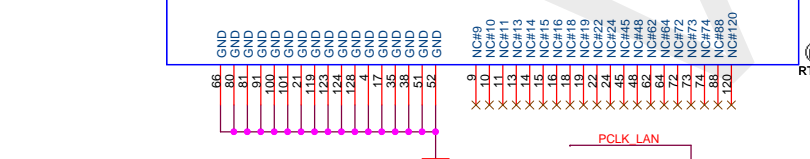
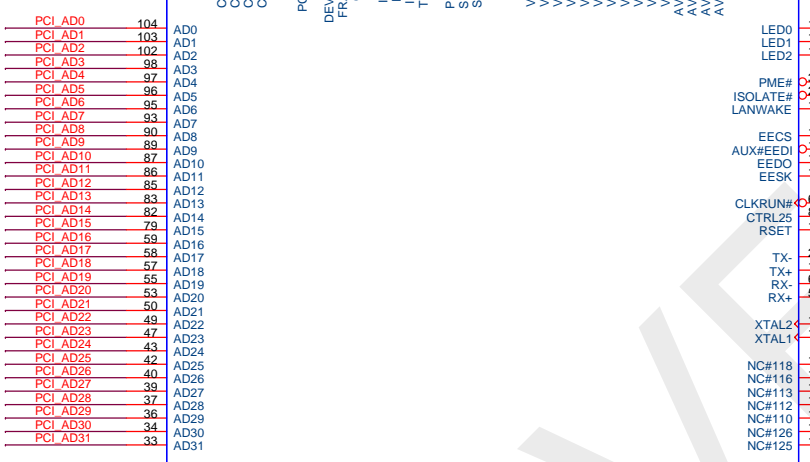
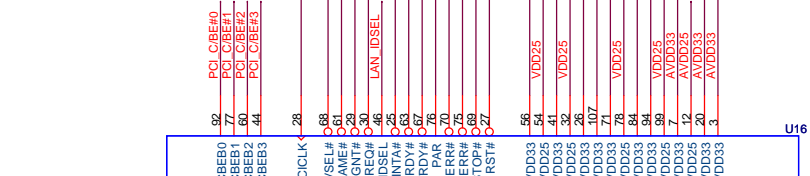

EEPROM LED OPTION USE '00'
 (DEFINED IN SPEC)
 => LED0 : ACT
 => LED1 : LINK 100
 => LED2 : LINK 10

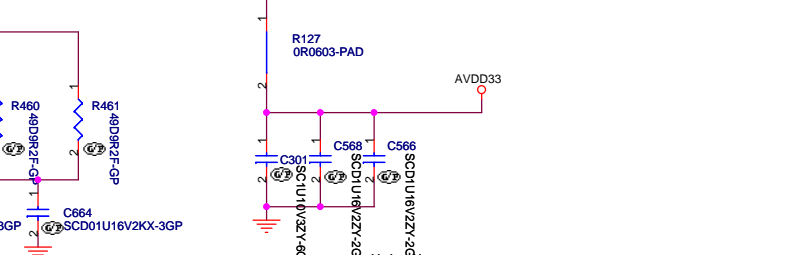
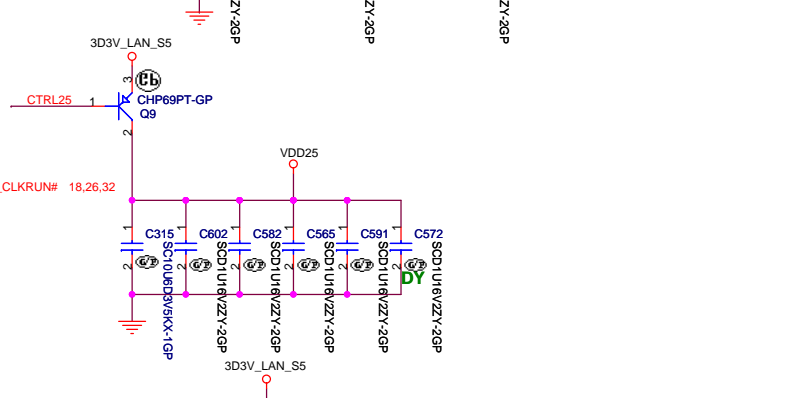
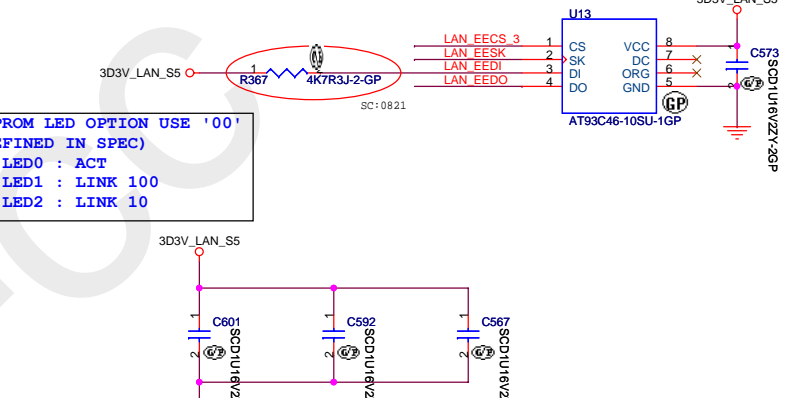
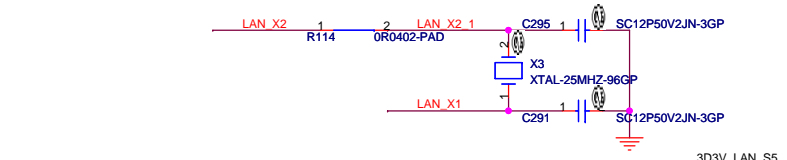
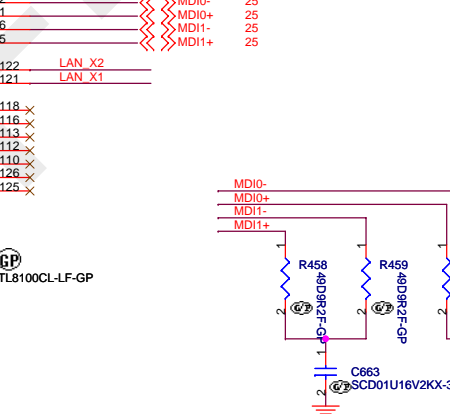
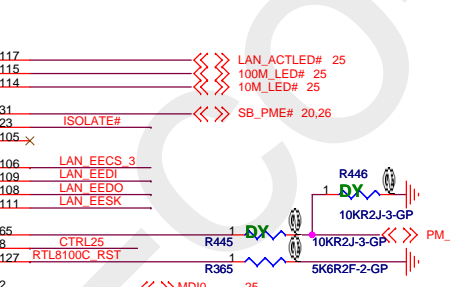

緯創資通 Wistron Corporation
 21F, 88, Sec.1, Hsin Tai Wu Rd., Hsichih,
 Taipei Hsien 221, Taiwan, R.O.C.

| | | |
|------------------------|----------------------------|----------------|
| Title | | |
| LAN RealTec - RLT8100C | | |
| Size | Document Number | Rev |
| A3 | DS2-AMD | 1 |
| Date: | Monday, September 24, 2007 | Sheet 24 of 44 |

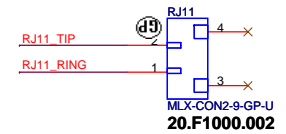
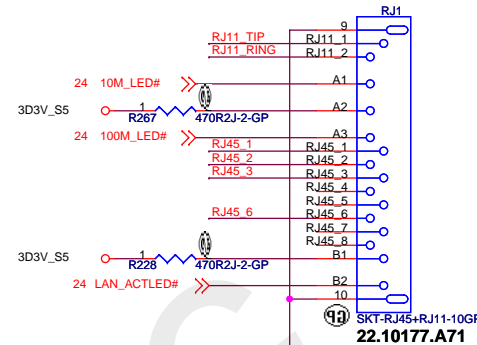
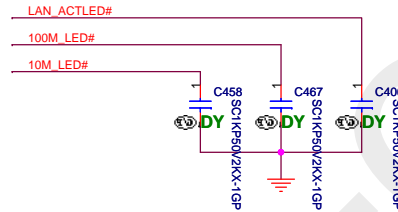
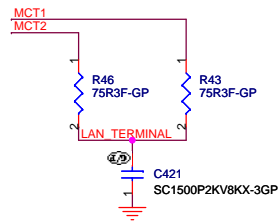
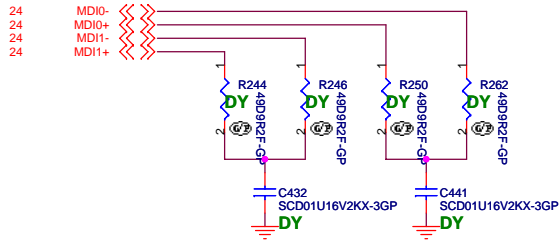
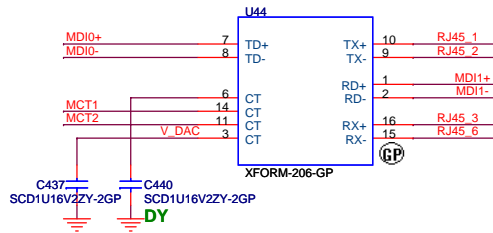

New card connector

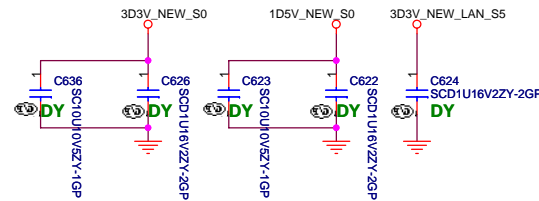
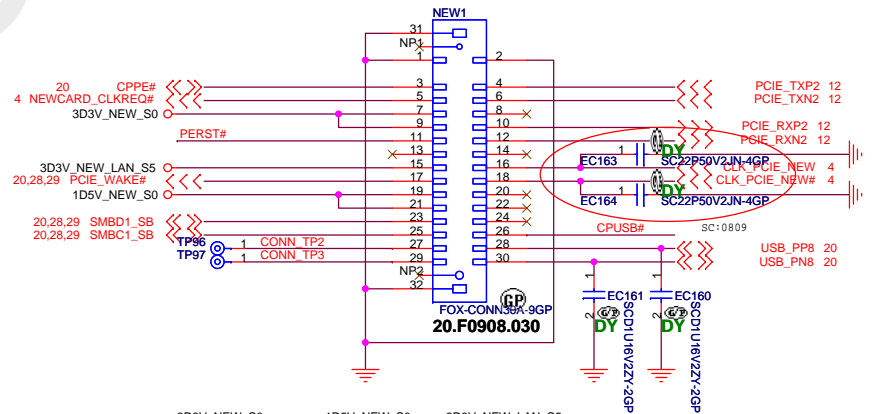
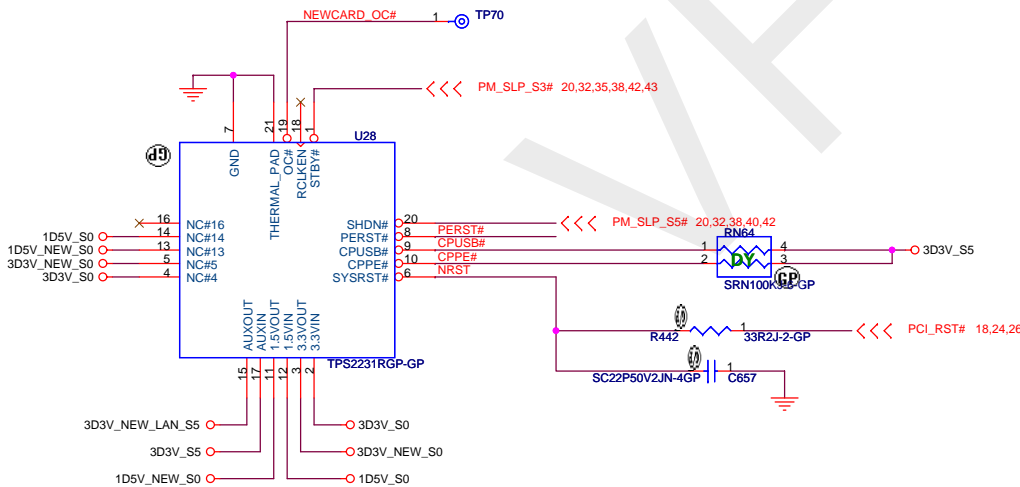
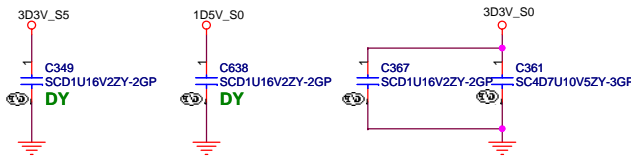

<Variant Name>

| | | |
|--|-----------------|----------|
| 緯創資通 Wistron Corporation 21F, 88, Sec. 1, Hsin Tai Wu Rd., Hsichih, Taipei Hsien 221, Taiwan, R.O.C. | | |
| LAN connector/NEW CARD/SIM | | |
| Title | | |
| Size A3 | Document Number | Rev |
| | DS2-AMD | 1 |
| Date: Monday, September 24, 2007 | Sheet 25 | of 44 |

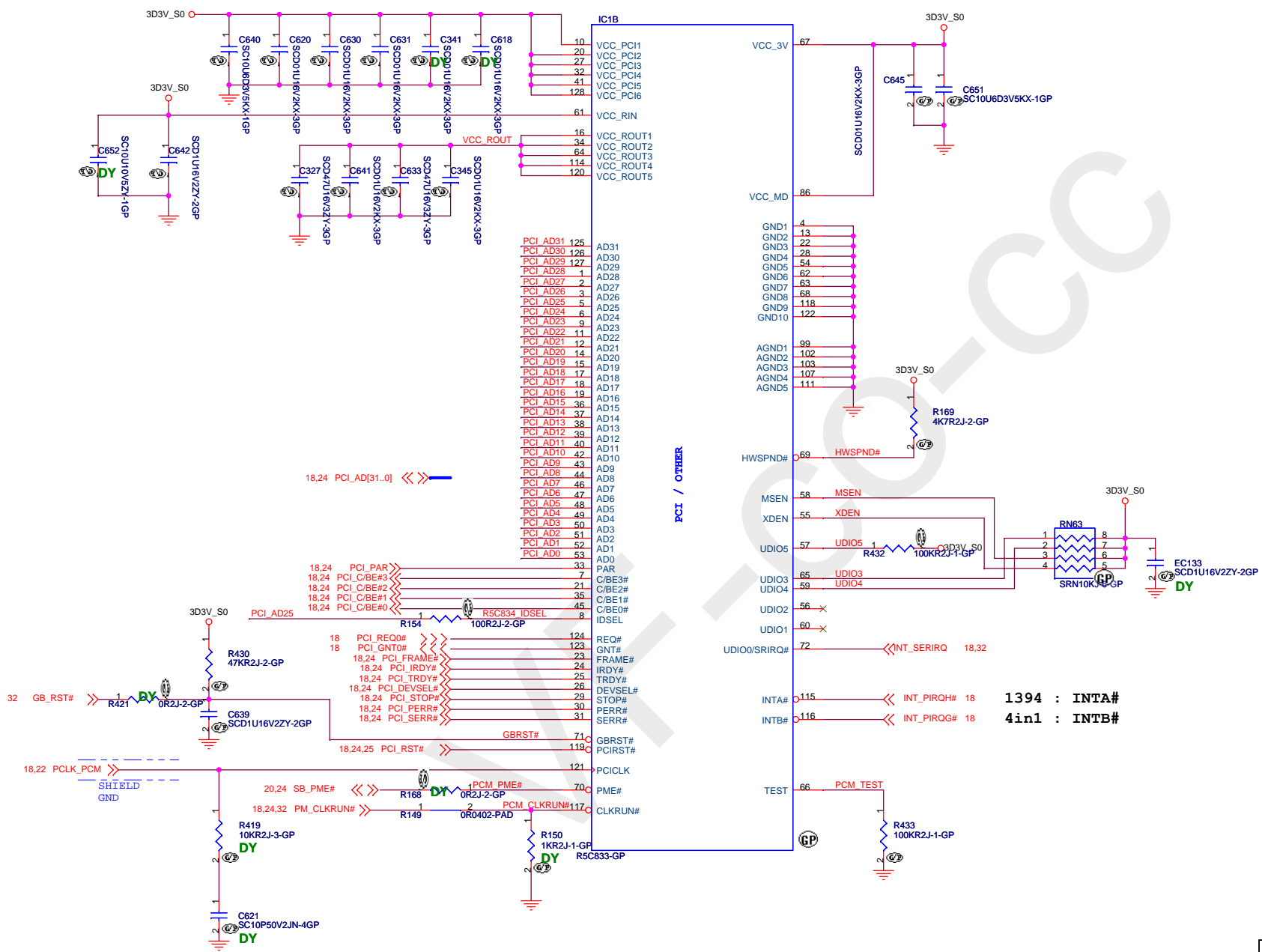

IC1B

| | |
|-----|-----------|
| 10 | VCC_PC1 |
| 20 | VCC_PC2 |
| 27 | VCC_PC3 |
| 32 | VCC_PC4 |
| 41 | VCC_PC5 |
| 128 | VCC_PC15 |
| 61 | VCC_RIN |
| 16 | VCC_ROUT1 |
| 34 | VCC_ROUT2 |
| 64 | VCC_ROUT3 |
| 114 | VCC_ROUT4 |
| 120 | VCC_ROUT5 |

| | |
|-----|---------|
| 125 | AD31 |
| 126 | AD30 |
| 127 | AD29 |
| 1 | AD28 |
| 2 | AD27 |
| 3 | AD26 |
| 5 | AD25 |
| 6 | AD24 |
| 9 | AD23 |
| 11 | AD22 |
| 12 | AD21 |
| 14 | AD20 |
| 15 | AD19 |
| 17 | AD18 |
| 18 | AD17 |
| 19 | AD16 |
| 36 | AD15 |
| 37 | AD14 |
| 38 | AD13 |
| 39 | AD12 |
| 40 | AD11 |
| 42 | AD10 |
| 43 | AD9 |
| 44 | AD8 |
| 46 | AD7 |
| 47 | AD6 |
| 48 | AD5 |
| 49 | AD4 |
| 50 | AD3 |
| 51 | AD2 |
| 52 | AD1 |
| 53 | AD0 |
| 33 | PAR |
| 7 | C/BE3# |
| 21 | C/BE2# |
| 35 | C/BE1# |
| 45 | C/BE0# |
| 8 | IDSEL |
| 124 | REQ# |
| 123 | GNT# |
| 23 | FRAME# |
| 24 | IRDY# |
| 25 | TRDY# |
| 26 | DEVSEL# |
| 29 | STOP# |
| 30 | PERR# |
| 31 | SERR# |
| 71 | GBRST# |
| 119 | PCIRST# |
| 121 | PCICLK |
| 70 | PME# |
| 117 | CLKRUN# |

PCI / OTHER

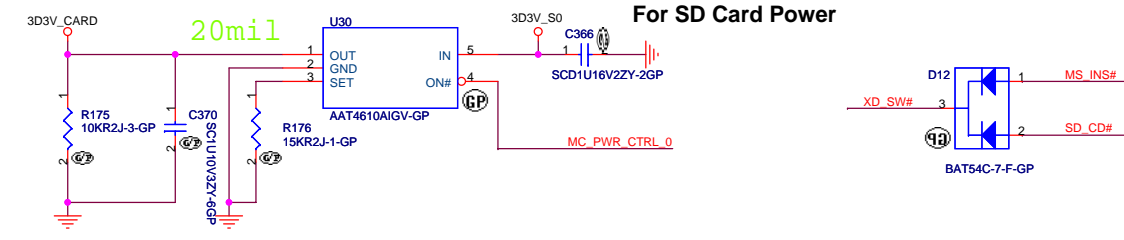
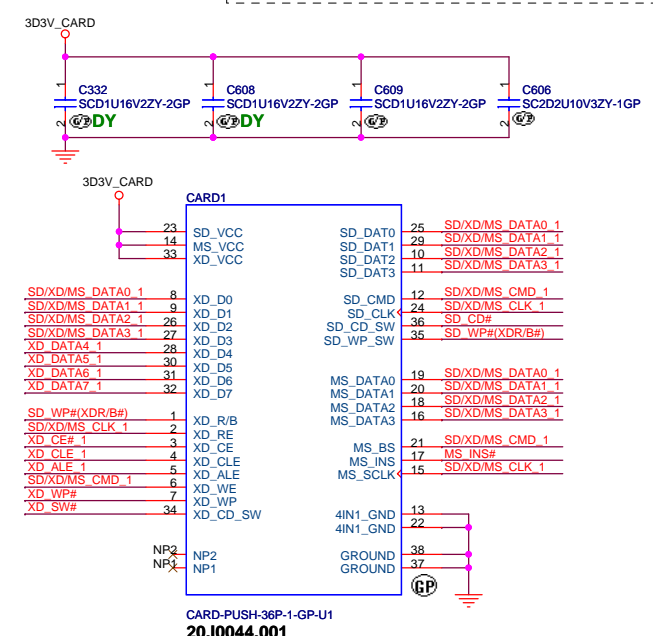
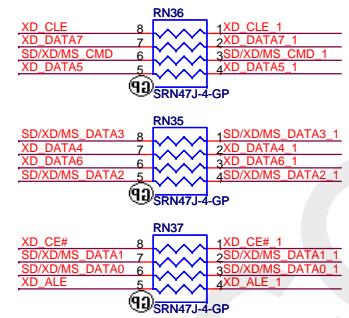
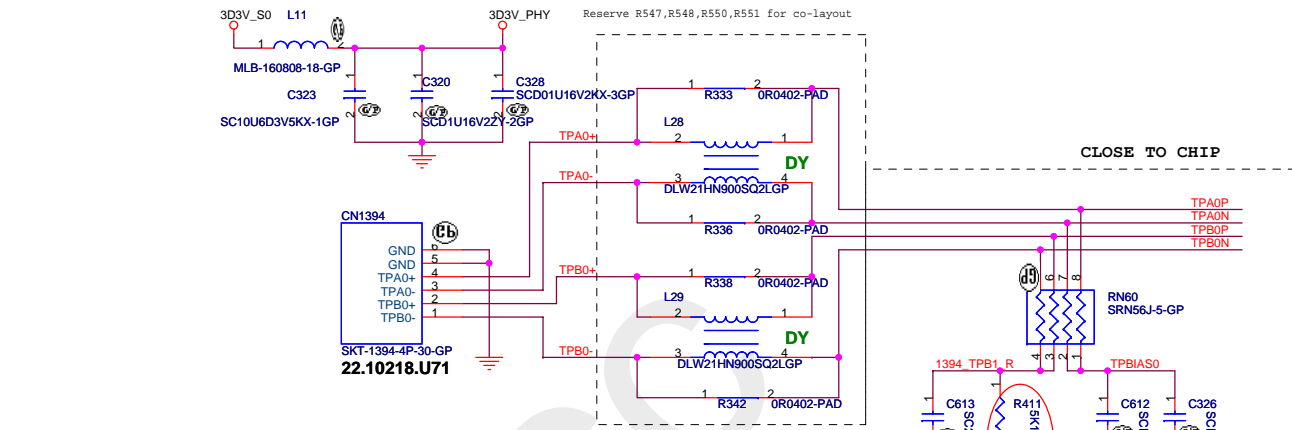
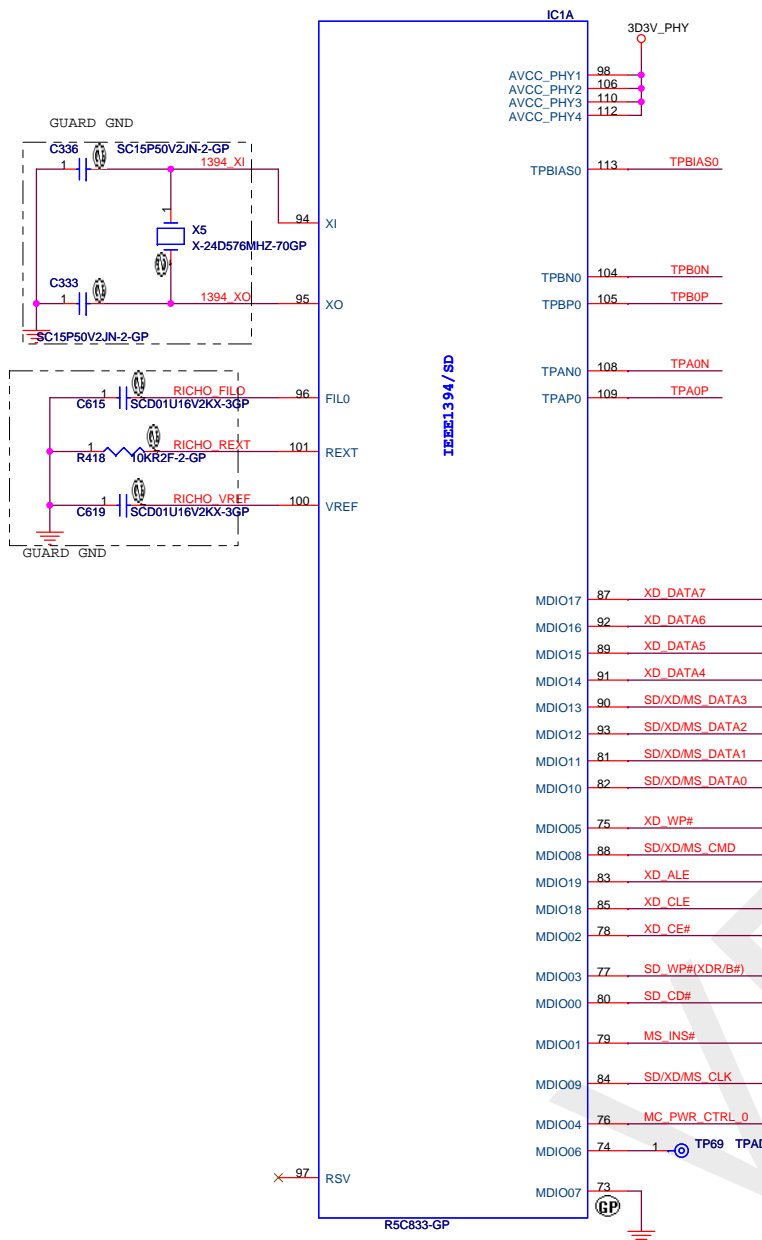

<Variant Name>

緯創資通 Wistron Corporation
21F, 88, Sec.1, Hsin Tai Wu Rd., Hsichih, Taipei Hsien 221, Taiwan, R.O.C.

Title: **R5C832/IEEE1394/SD**

| | | |
|---------|--------------------------------|--------------|
| Size A3 | Document Number DS2-AMD | Rev 1 |
|---------|--------------------------------|--------------|

Date: Monday, September 24, 2007 Sheet 27 of 44

Mini Card Connector 1(802.11a/b/g)

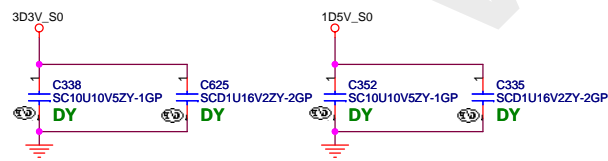
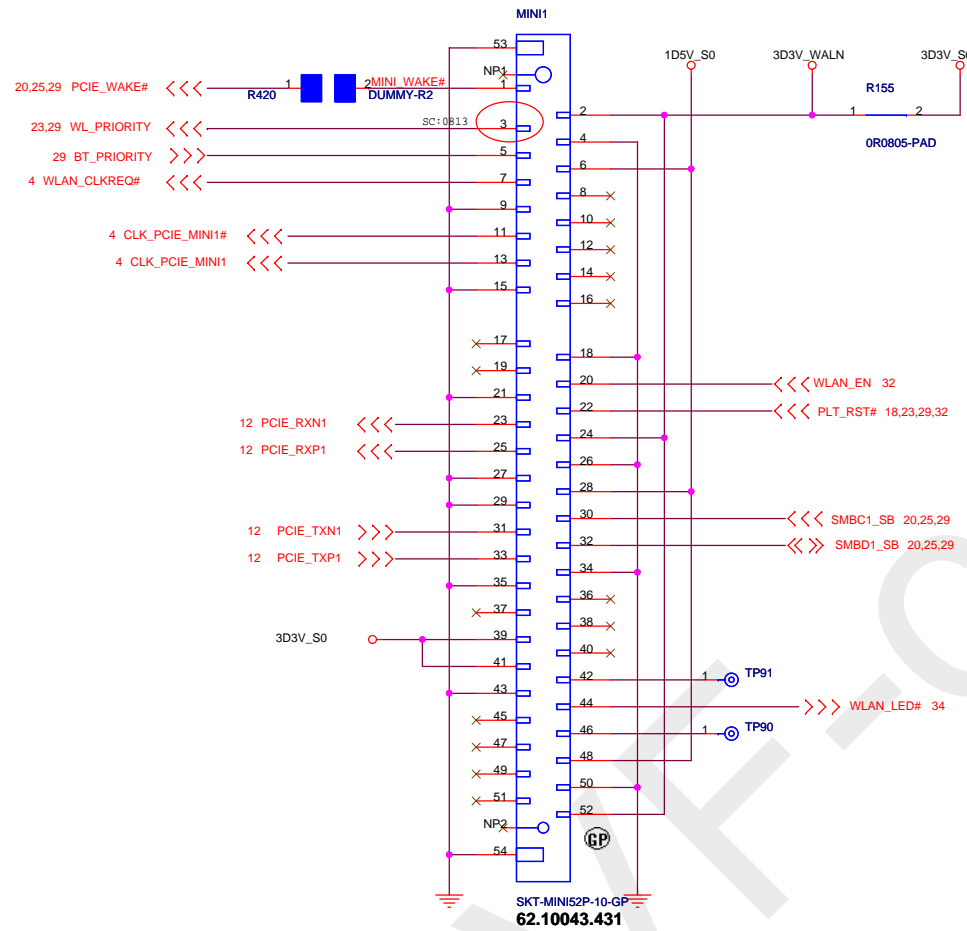

Mini Card Connector 2(UWB)

Mini Card Connector 3(WWAN)

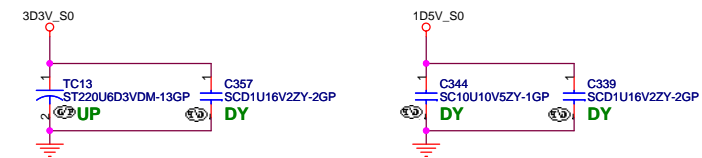
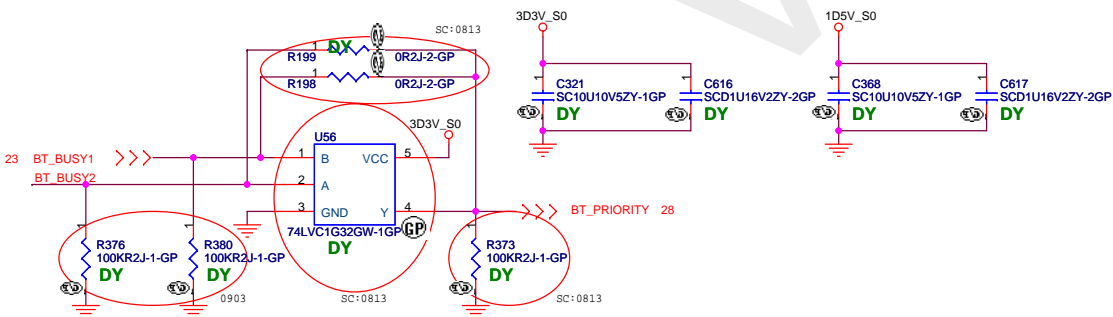
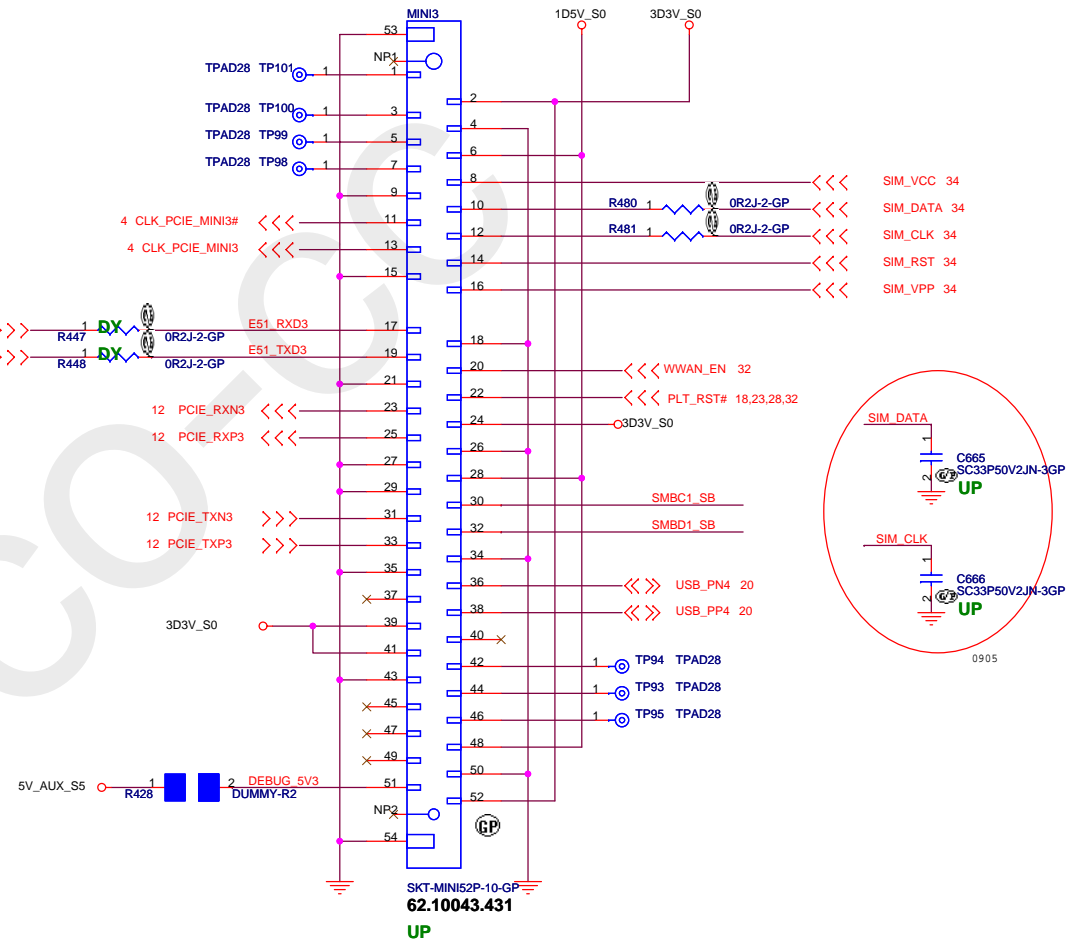
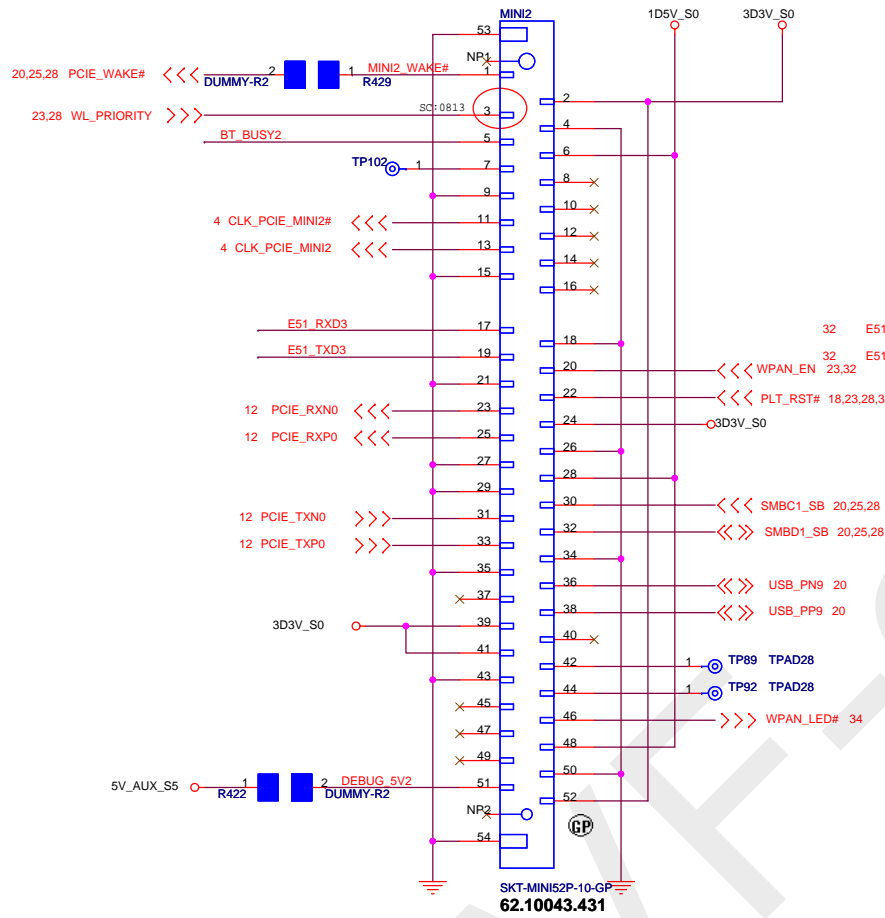

<Variant Name>

緯創資通 Wistron Corporation
21F, 88, Sec.1, Hsin Tai Wu Rd., Hsichih, Taipei Hsien 221, Taiwan, R.O.C.

Title: **MINI CARD CONN.**

Size: A3 Document Number: **DS2-AMD** Rev: **1**

Date: Monday, September 24, 2007 Sheet 29 of 44

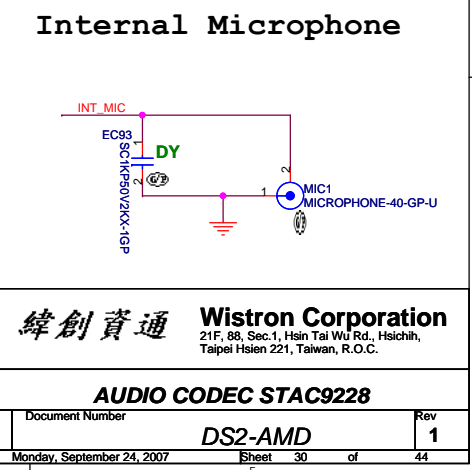
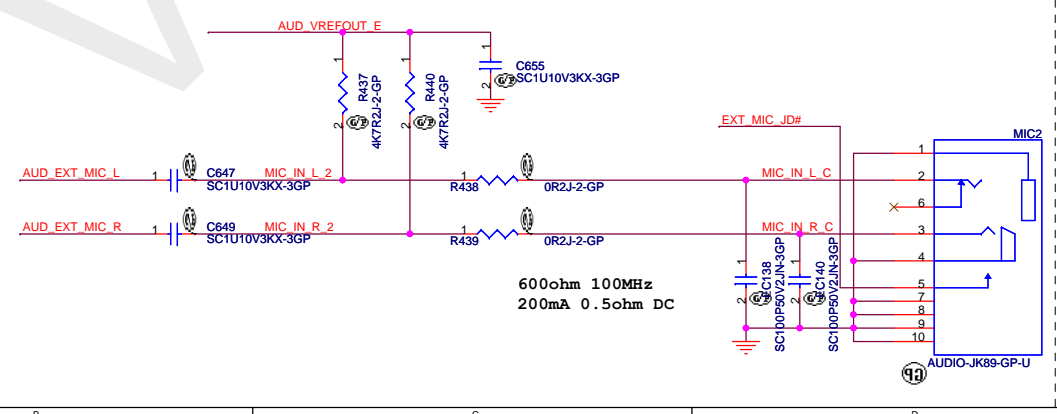
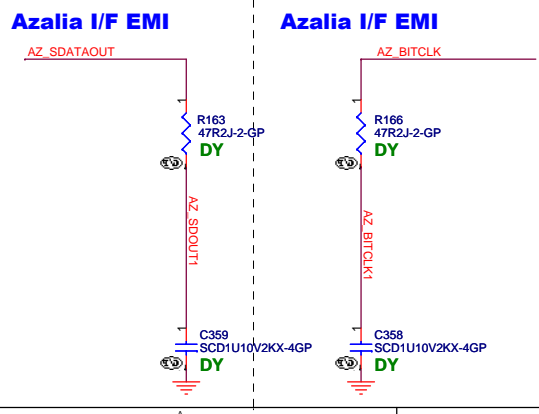
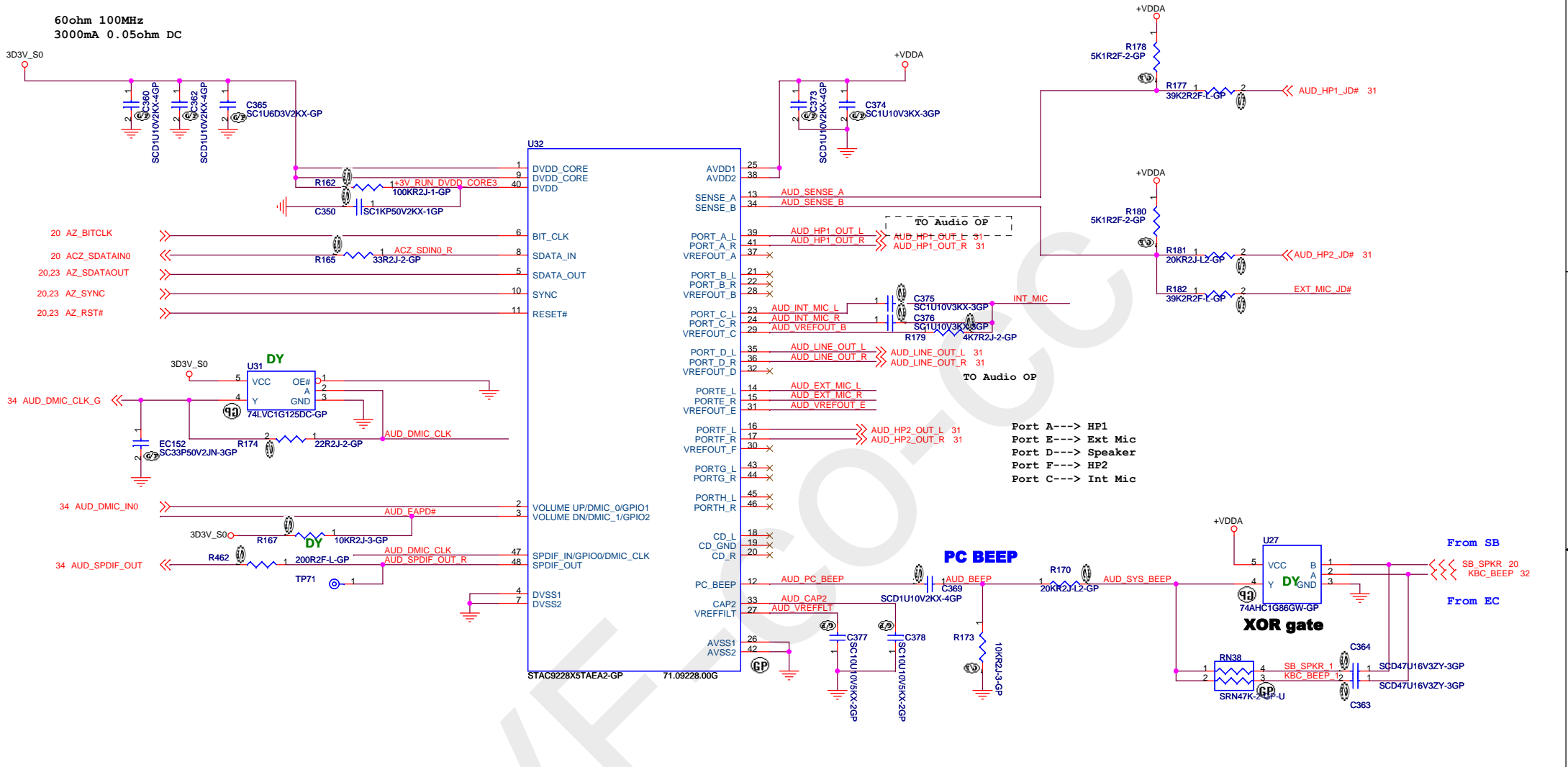

緯創資通 Wistron Corporation
21F, 88, Sec.1, Hsin Tai Wu Rd., Hsichih, Taipei Hsien 221, Taiwan, R.O.C.

Title: **AUDIO CODEC STAC9228**

| | | |
|---------|-----------------|----------|
| Size A3 | Document Number | Rev |
| | DS2-AMD | 1 |

Date: Monday, September 24, 2007 Sheet 30 of 44

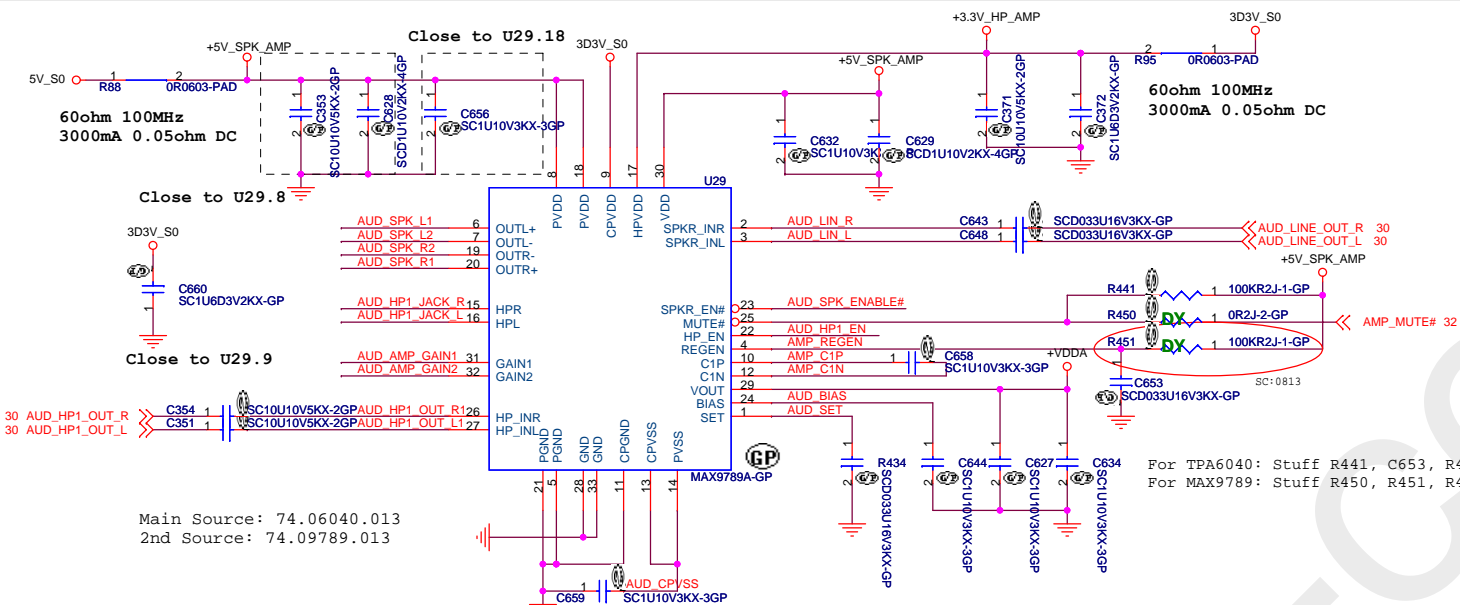

Speaker

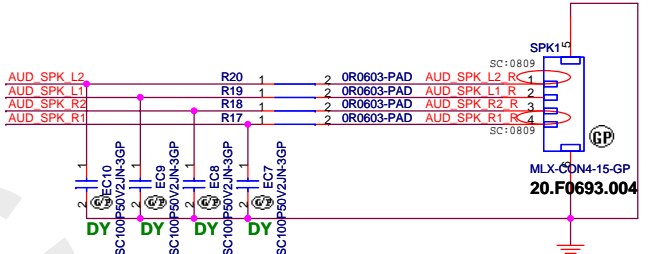

LINE1 OUT

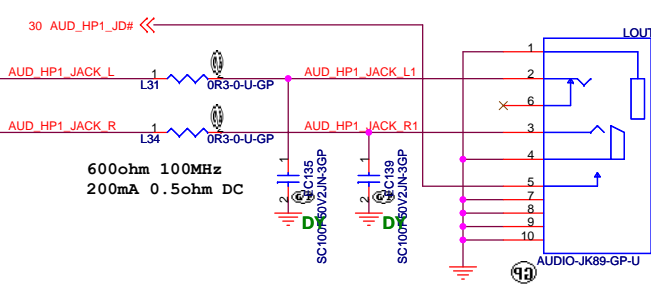

LINE2 OUT

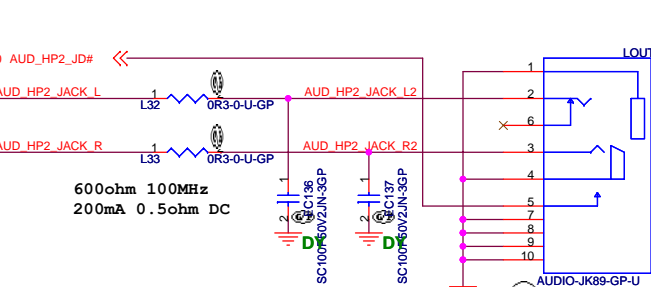

GAIN SETTING

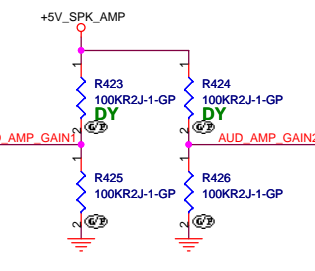

| GAIN1 | GAIN2 | GAIN |
|-------|-------|--------|
| 0 | 0 | 6dB |
| 0 | 1 | 10dB |
| 1 | 0 | 15.6dB |
| 1 | 1 | 21.6dB |

Signal inverter for speaker shutdown

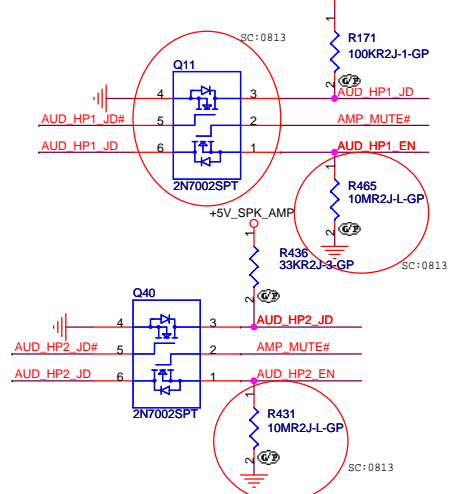
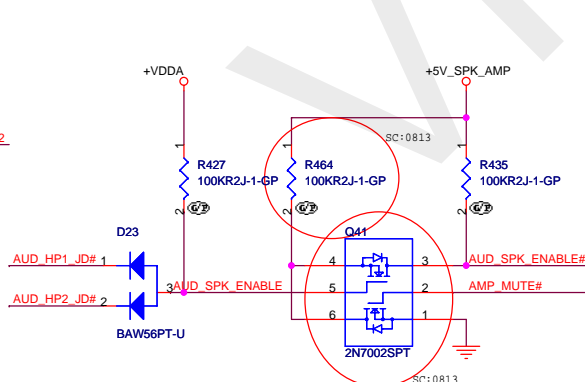

緯創資通 Wistron Corporation
21F, 88, Sec.1, Hsin Tai Wu Rd., Hsichih, Taipei Hsien 221, Taiwan, R.O.C.

File: **AUDIO AMP/SPEAKER**

Size A3 Document Number **DS2-AMD** Rev **1**

Date: Monday, September 24, 2007 Sheet 31 of 44

WPC8763L STRAP PIN

| JEN0 (Pin 24) | JENK (Pin 53) | Functionality of Pins 17, 20, 21, 23 25, 27 | Functionality of Pins 47, 48, 50, 51, 52 |
|---------------|---------------|---|--|
| NO PD RES | GPIO Port | Keyboard Scan | Keyboard Scan |
| 10K PD | NO PD | | JTAG signals |
| NO PD | 10K PD | | GPIO Port |

TRIS#(Pin 110) TRI-STATE

Forces the device to float all its output and I/O pins, if an external 10 KΩ pull-down resistor is connected.

BADDR1-0 (PIN 114, 112) I/O Base Address.

10KΩ external pull-down resistor on BADDR1: Core defined

SHBM PIPN83 Shared Host BIOS Memory.

HIGH:NO SHARED(internal resistor)
LOW:SHARED BIOS memory.

B

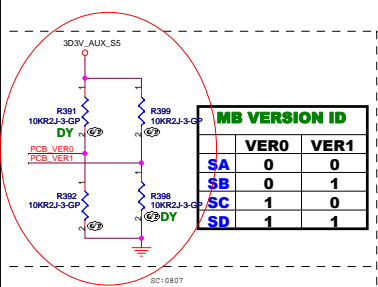

| MB VERSION ID | | |
|---------------|------|------|
| | VER0 | VER1 |
| SA | 0 | 0 |
| SB | 0 | 1 |
| SC | 1 | 0 |
| SD | 1 | 1 |

A

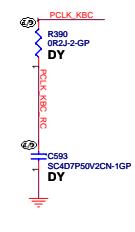
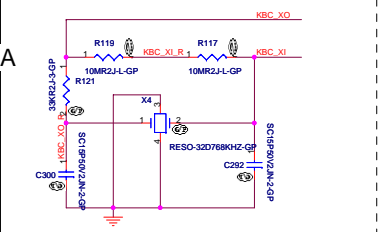

5

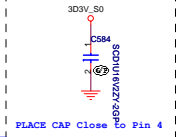

4



3



3

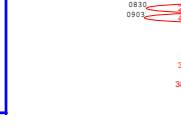

3



3



3



3



3



3

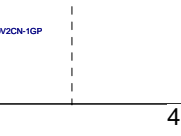

3

5



4

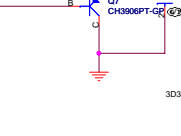

3



3

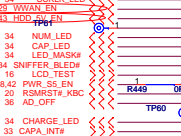

3

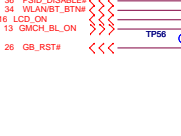

3



3



3



3



3



3

5

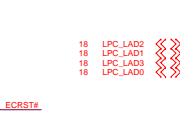

4

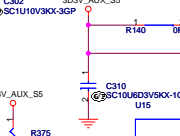

3

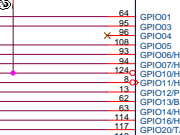

3

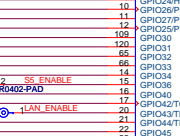

3

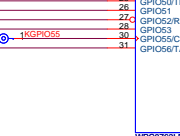

3

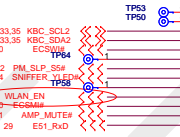

3



3

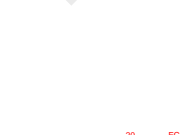

3



3

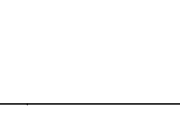

3

5

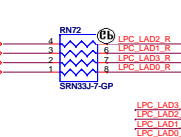

4

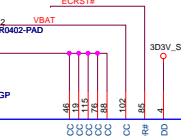

3



3



3

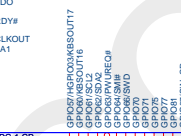

3

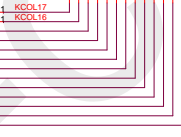

3

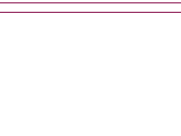

3

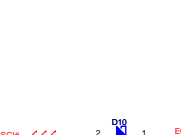

3

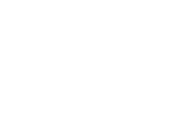

3

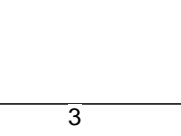

3

5



4

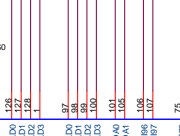

3



3



3



3

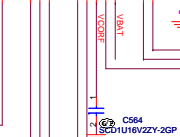

3



3



3



3

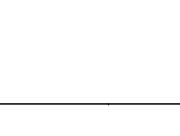

3

5

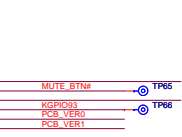

4

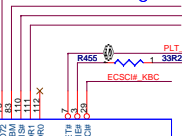

3



3



3

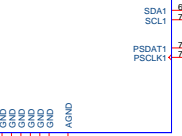

3



3



3



3



3

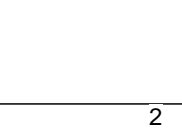

3

5



4

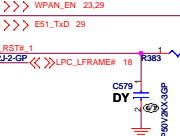

3

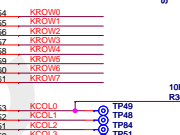

3

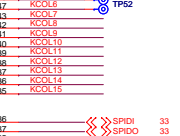

3

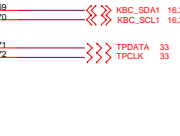

3

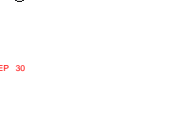

3



3



3



3



3

5



4

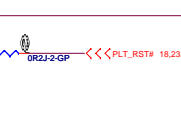

3

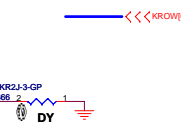

3

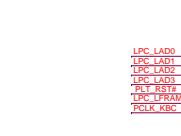

Internal KeyBoard Connector

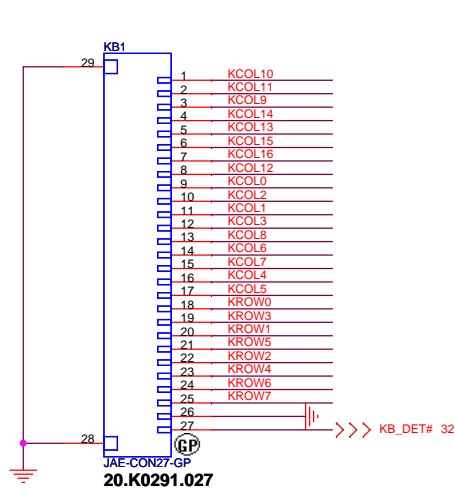

SPI ROM

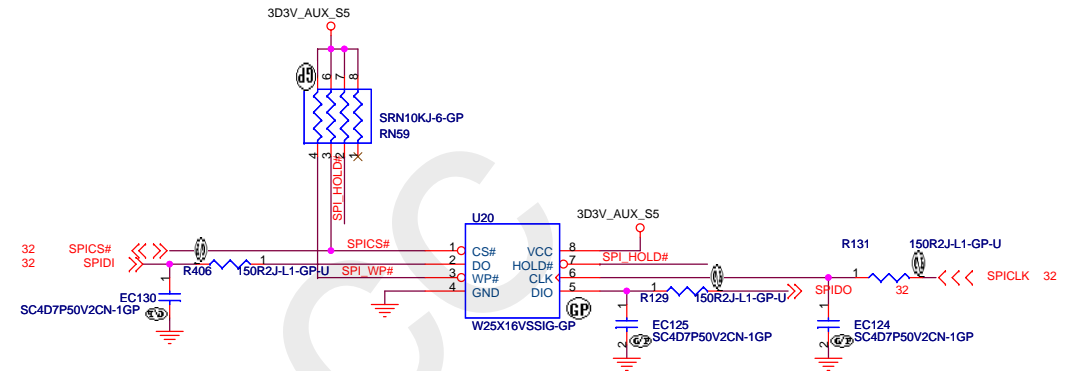

CAPACITY BUTTON

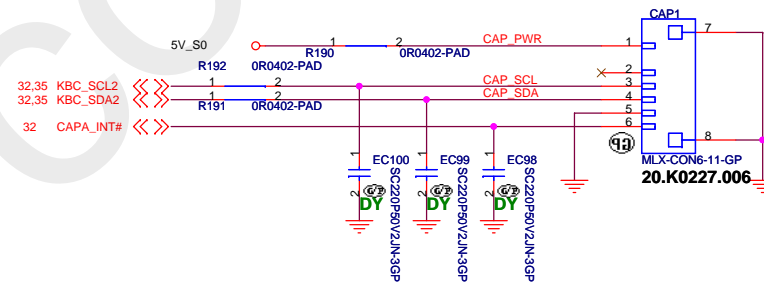

TouchPad Connector

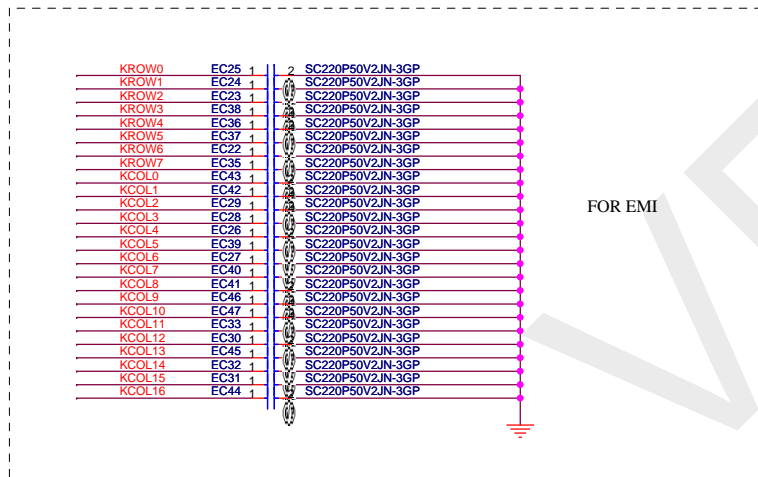
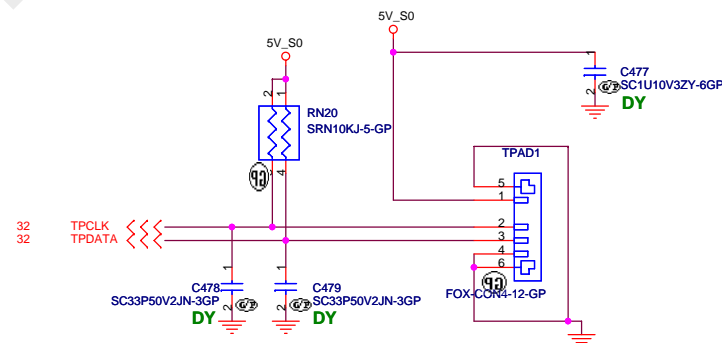

緯創資通 Wistron Corporation
21F, 88, Sec.1, Hsin Tai Wu Rd., Hsichih, Taipei Hsien 221, Taiwan, R.O.C.

| | | |
|---------------|-------------------------------|----------------|
| Title | | |
| KeyBoard-CONN | | |
| Size | Document Number | Rev |
| A3 | DS2-AMD | 1 |
| Date: | Wednesday, September 26, 2007 | Sheet 33 of 44 |

CAMERA/D.MIC Connector

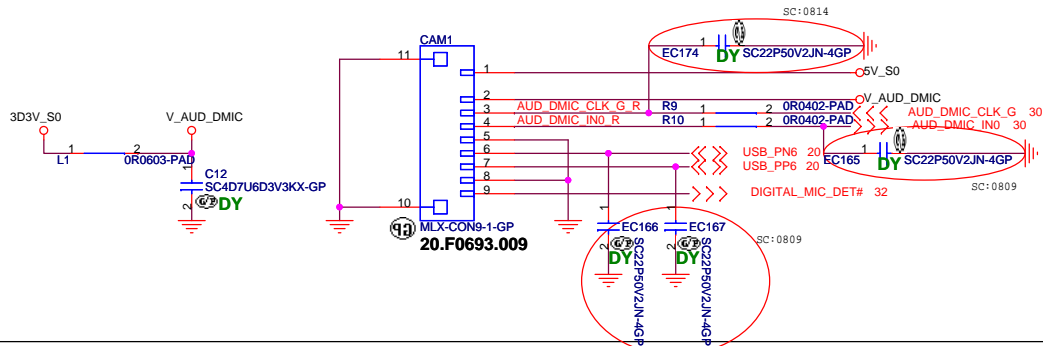

Power Dash Board Connector

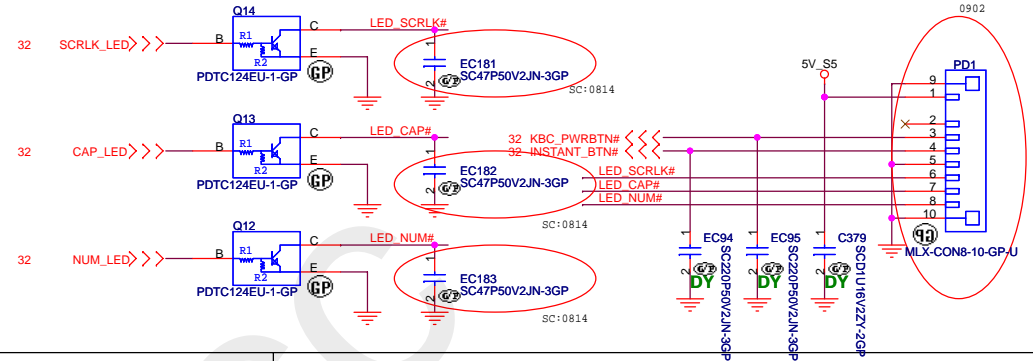

LED Board Connector

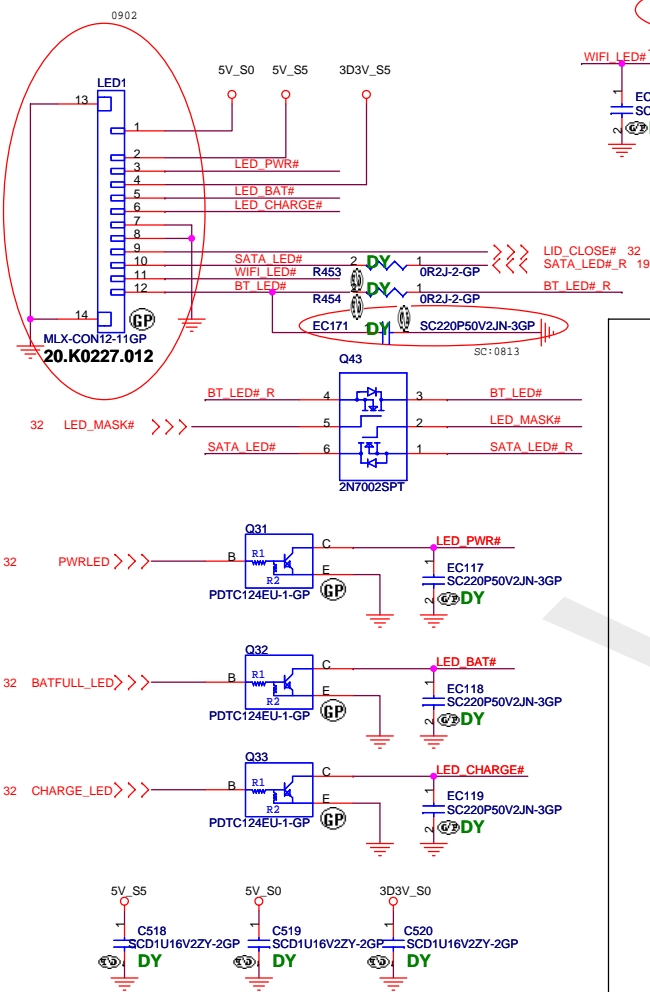

RIGHT I/O Board Connector

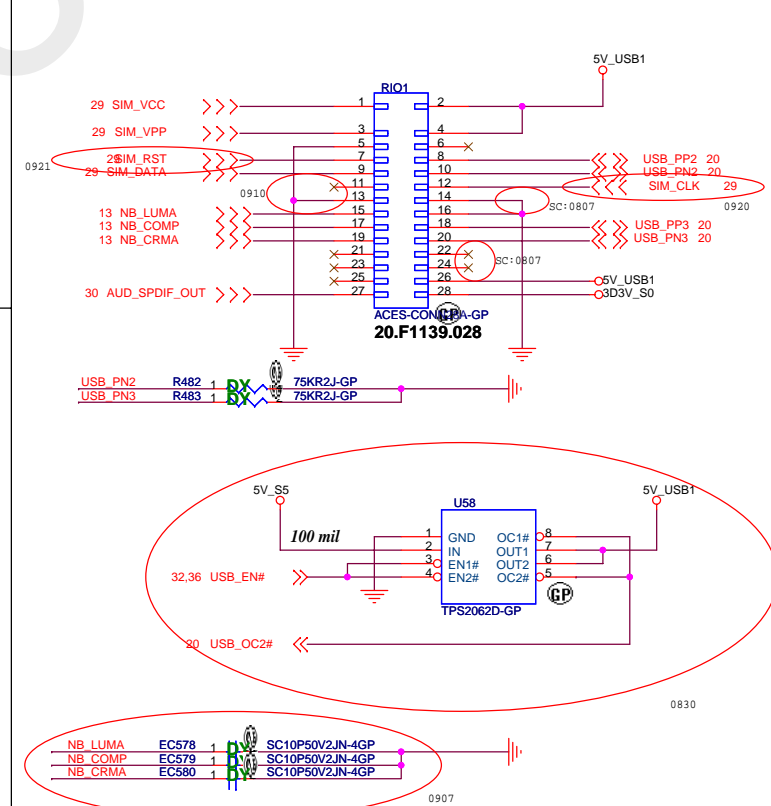

SNIFFER Board Connector

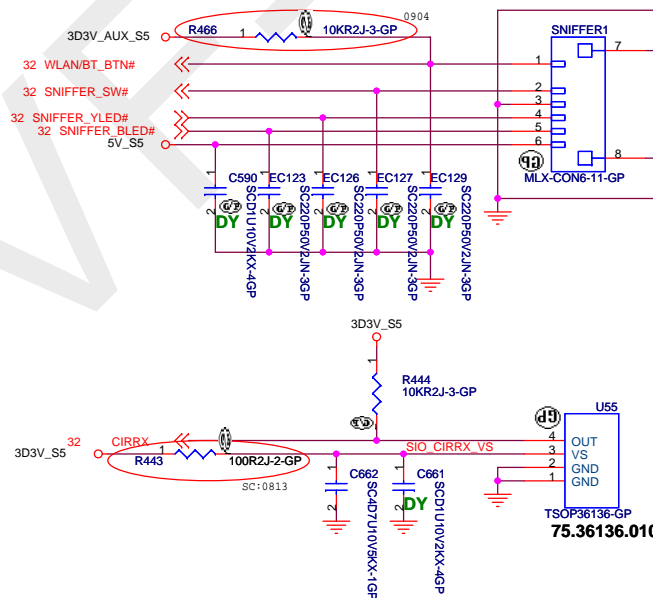

緯創資通 Wistron Corporation
21F, 88, Sec.1, Hsin Tai Wu Rd., Hsichih, Taipei Hsien 221, Taiwan, R.O.C.

| | | | | | |
|-------|----------------------------|-------|-----------------------|----|----|
| Title | | | BOARD to BOARD | | |
| Size | Document Number | | Rev | | 1 |
| A3 | DS2-AMD | | | | |
| Date: | Monday, September 24, 2007 | Sheet | 34 | of | 44 |

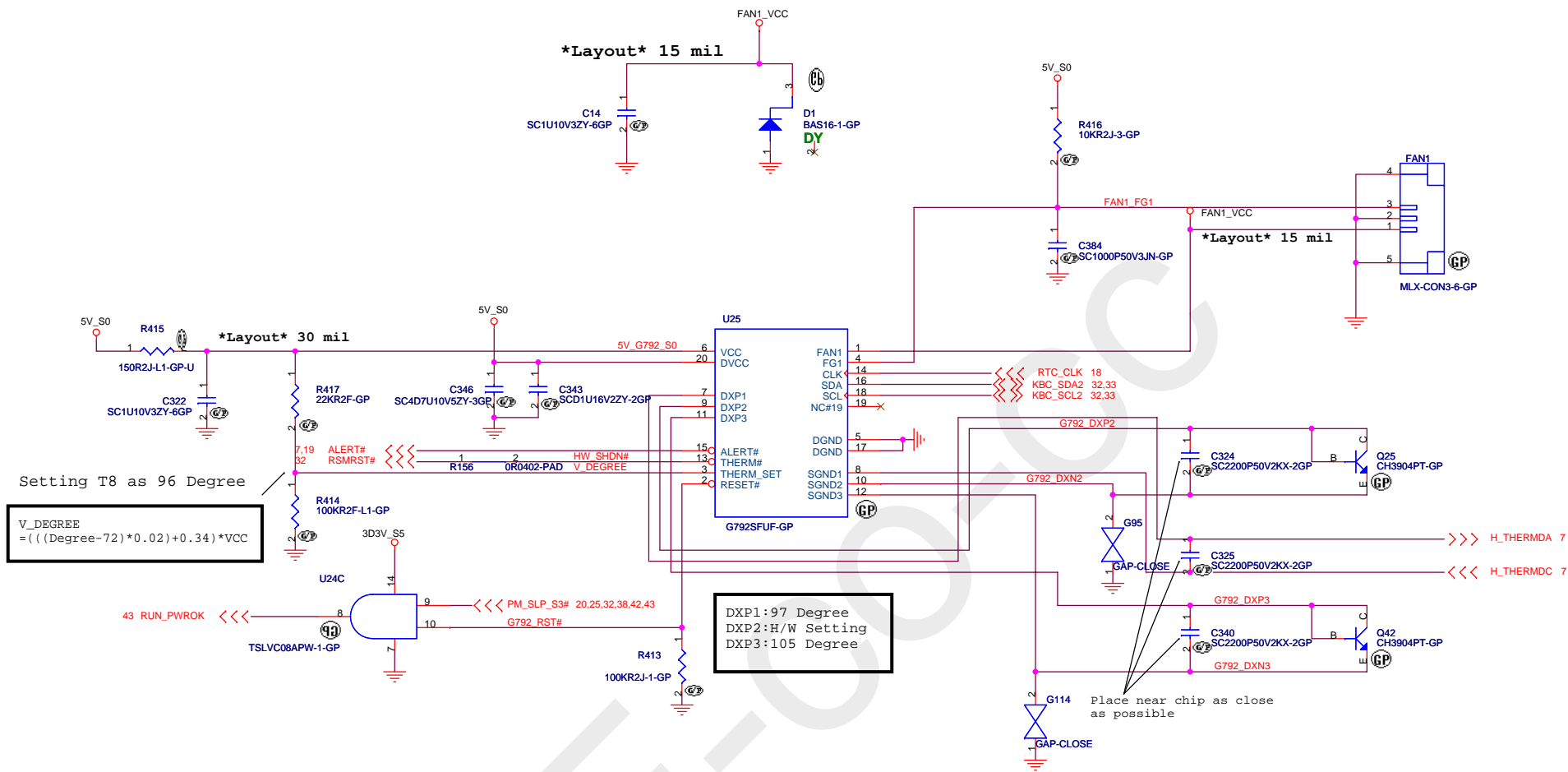

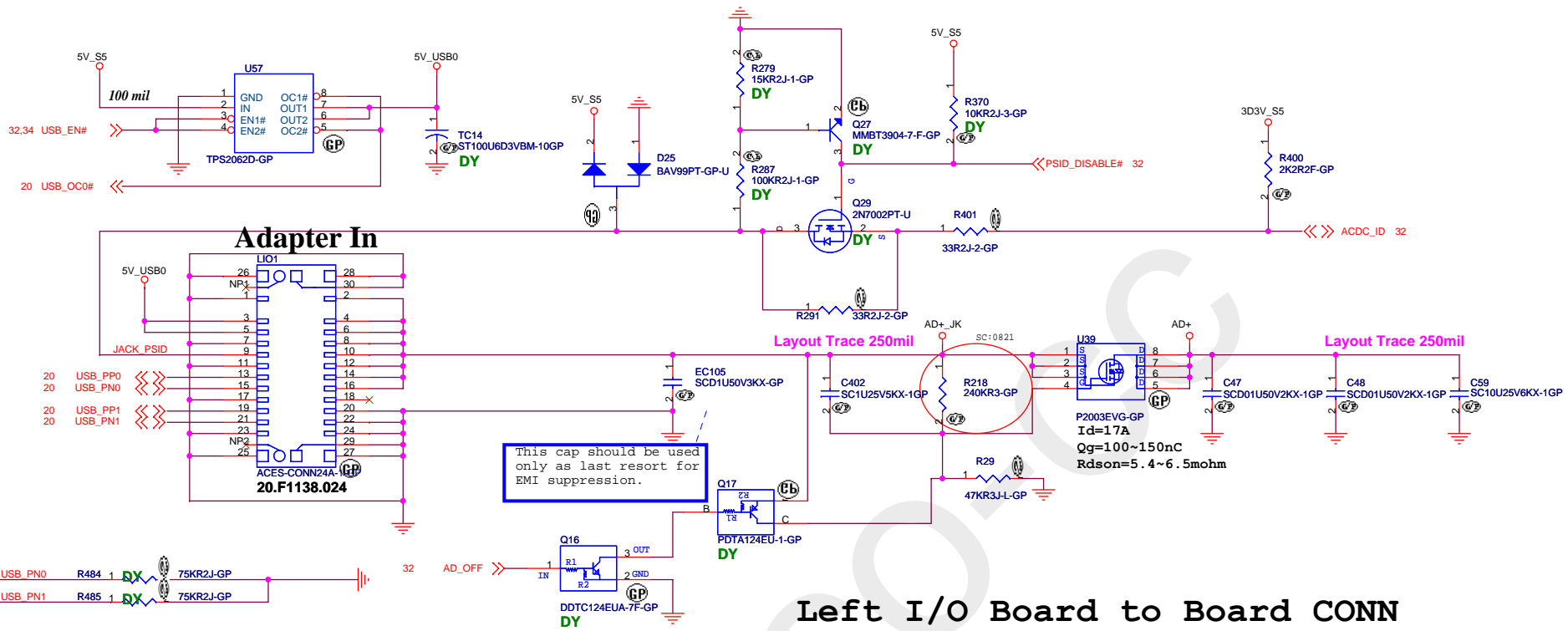

Left I/O Board to Board CONN

Batt CONN

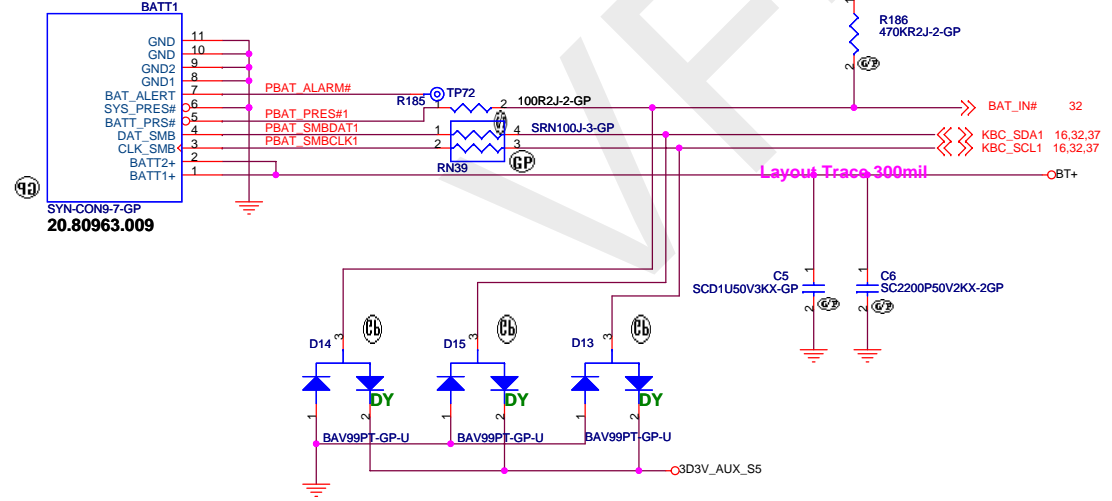

<Variant Name>

緯創資通 Wistron Corporation
21F, 88, Sec.1, Hsin Tai Wu Rd., Hsichih, Taipei Hsien 221, Taiwan, R.O.C.

Title
AD/BATT CONN

| | | |
|------------|----------------------------|----------|
| Size A3 | Document Number DS2-AMD | Rev 1 |
|------------|----------------------------|----------|

Date: Monday, September 24, 2007 Sheet 36 of 44

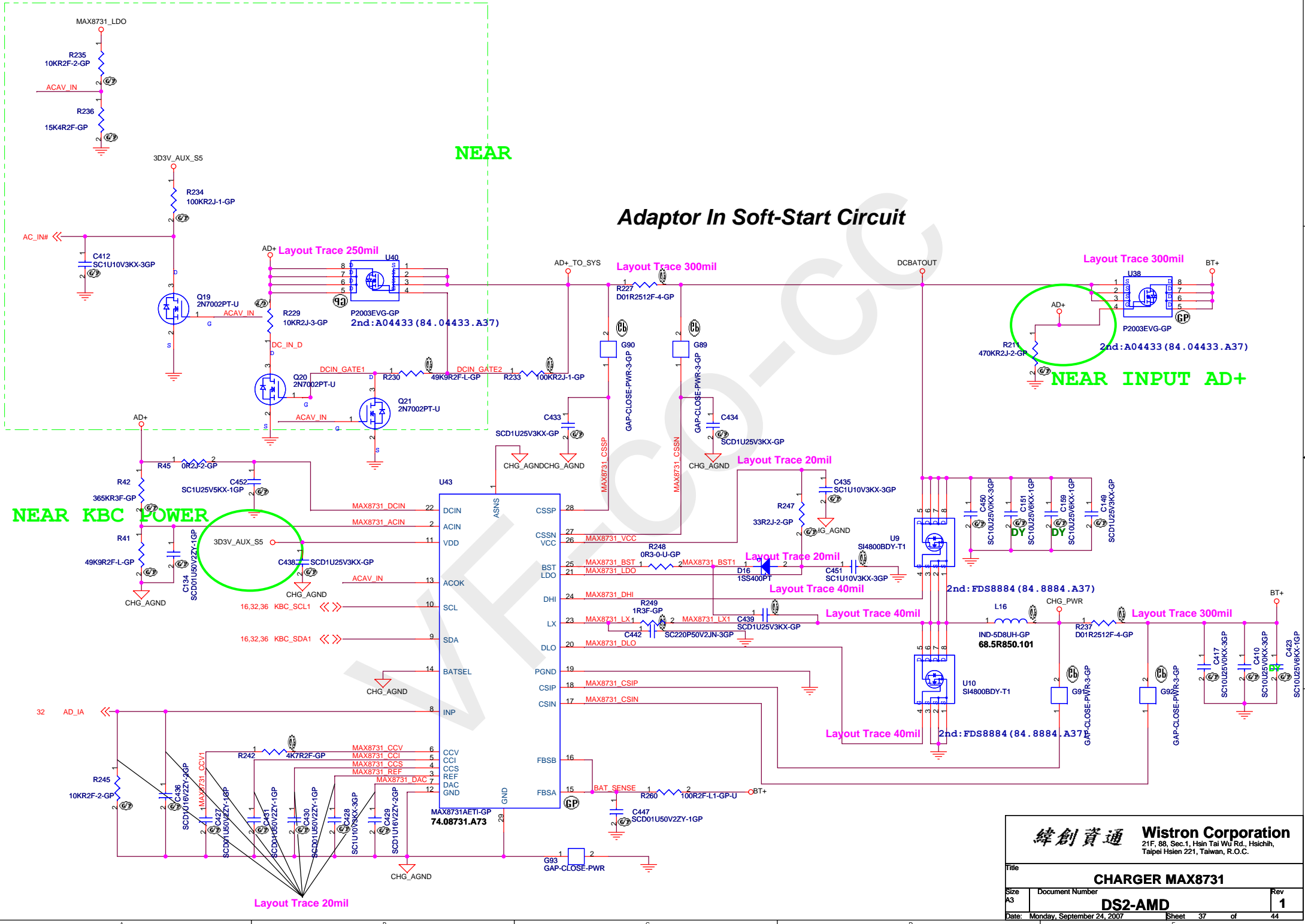

Adaptor In Soft-Start Circuit

NEAR INPUT AD+

NEAR KBC POWER

NEAR

緯創資通 Wistron Corporation
 21F, 88, Sec.1, Hsin Tai Wu Rd., Hsichih,
 Taipei Hsien 221, Taiwan, R.O.C.

| | | | | | |
|-------|----------------------------|-------|------------------------|----|----|
| Title | | | CHARGER MAX8731 | | |
| Size | Document Number | | Rev | | |
| A3 | DS2-AMD | | 1 | | |
| Date: | Monday, September 24, 2007 | Sheet | 37 | of | 44 |

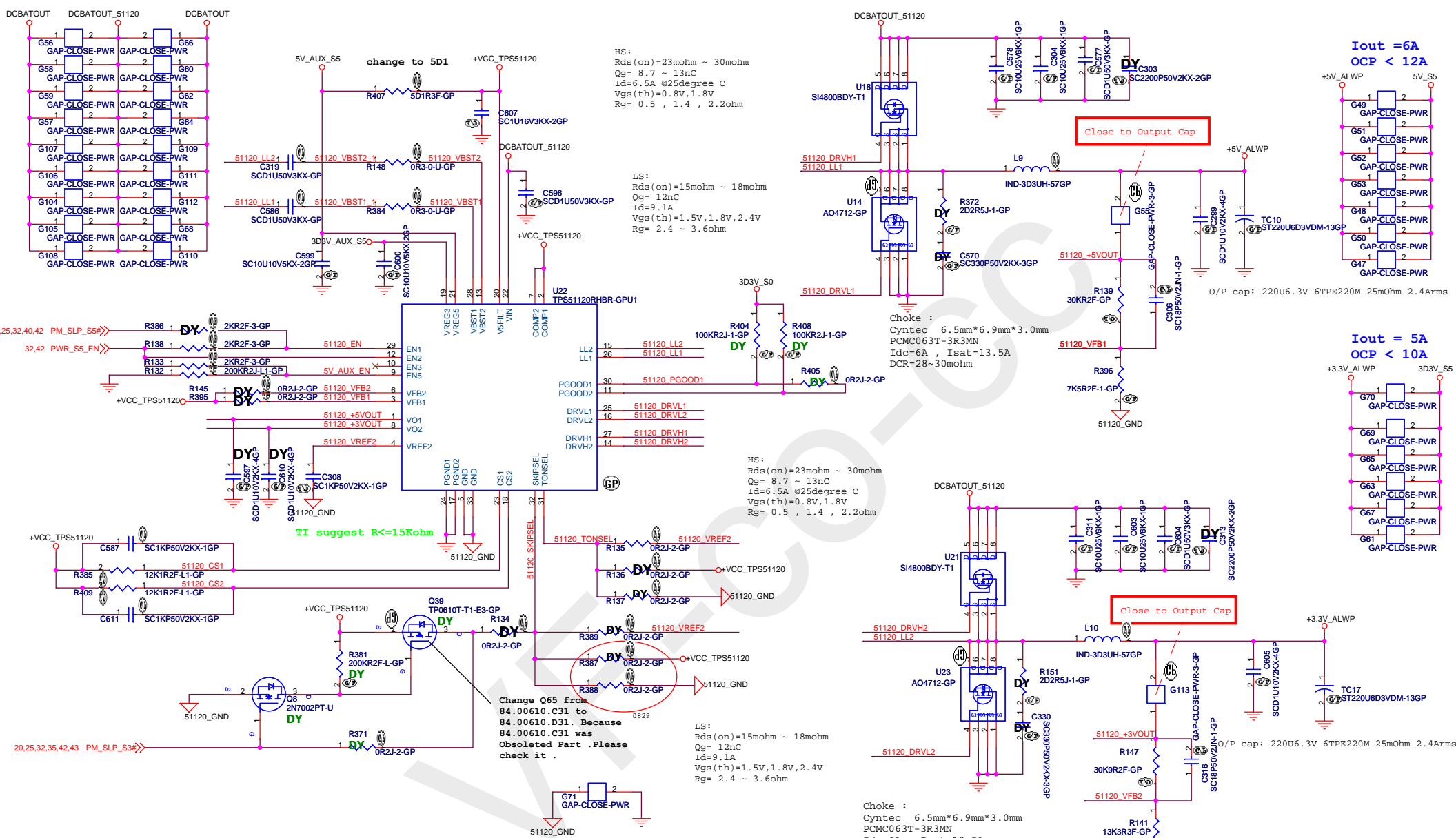

HS:
 $R_{ds(on)} = 23\text{m}\Omega \sim 30\text{m}\Omega$
 $Q_g = 8.7 \sim 13\text{nC}$
 $I_d = 6.5\text{A} @ 25^\circ\text{C}$
 $V_{gs(th)} = 0.8\text{V}, 1.8\text{V}$
 $R_g = 0.5, 1.4, 2.2\text{ohm}$

LS:
 $R_{ds(on)} = 15\text{m}\Omega \sim 18\text{m}\Omega$
 $Q_g = 12\text{nC}$
 $I_d = 9.1\text{A}$
 $V_{gs(th)} = 1.5\text{V}, 1.8\text{V}, 2.4\text{V}$
 $R_g = 2.4 \sim 3.6\text{ohm}$

HS:
 $R_{ds(on)} = 23\text{m}\Omega \sim 30\text{m}\Omega$
 $Q_g = 8.7 \sim 13\text{nC}$
 $I_d = 6.5\text{A} @ 25^\circ\text{C}$
 $V_{gs(th)} = 0.8\text{V}, 1.8\text{V}$
 $R_g = 0.5, 1.4, 2.2\text{ohm}$

LS:
 $R_{ds(on)} = 15\text{m}\Omega \sim 18\text{m}\Omega$
 $Q_g = 12\text{nC}$
 $I_d = 9.1\text{A}$
 $V_{gs(th)} = 1.5\text{V}, 1.8\text{V}, 2.4\text{V}$
 $R_g = 2.4 \sim 3.6\text{ohm}$

Choke :
 Cyntec 6.5mm*6.9mm*3.0mm
 PCMC063T-3R3MN
 $I_{dc} = 6\text{A}$, $I_{sat} = 13.5\text{A}$
 $DCR = 28 \sim 30\text{m}\Omega$

$I_{out} = 6\text{A}$
 $OCV < 12\text{A}$

$I_{out} = 5\text{A}$
 $OCV < 10\text{A}$

$$V_{out} = 1V * (R1 + R2) / R2$$

| | GND | VREF2 | FLOK1 | VSFILT |
|----------|----------------------|-----------------------|----------------------|-----------------------|
| SKIPSEL | AUTOSKIP | AUTOSKIP / FAULTS OFF | PWM | PWM |
| COMP | N/A | N/A | CURRENT MODE | D-Cap MODE |
| TONSEL | 380k/CH1 580k/CH2 | 280k/CH1 430k/CH2 | 220k/CH1 330k/CH2 | 180k/CH1 2870k/CH2 |
| VFB1 | N/A | not use | ADJ. | Fixed Output |
| VFB2 | N/A | not use | ADJ. | 3.3V Fixed Output |
| EN1, EN2 | Switcher OFF | not use | Switcher ON | Switcher ON |
| EN3, EN5 | LDO OFF | not use | LDO ON | VREG3 on |

緯創資通 Wistron Corporation
 21F, 88, Sec.1, Hsin Tai Wu Rd., Hsichih, Taipei Hsien 221, Taiwan, R.O.C.

Title: **3V/5V TPS51120**

Size Custom: Document Number **DS2-AMD** Rev **1**

Date: Monday, September 24, 2007 Sheet 38 of 44

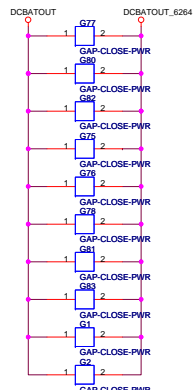

SET "H"---Audio filter
 RBIAS=1.55V
 Inner 3K ohm
 Positive offset:
 (1.2V/R7)*R11

OCP: 40A*1.25=50A
 50A*2mV/A=10uA*Roreset
 Roreset=10K

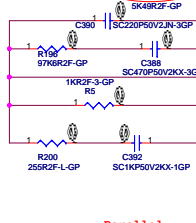

7 COREFB <<<< Parallel
 7 COREFB# <<<< Parallel

| TABLE 1. VOLTAGE IDENTIFICATION CODES | | | | | | | | | |
|---------------------------------------|------|------|------|------|------|-------|--|--|--|
| VID5 | VID4 | VID3 | VID2 | VID1 | VID0 | DAC | | | |
| 0 | 0 | 0 | 0 | 0 | 0 | 1.550 | | | |
| 0 | 0 | 0 | 0 | 0 | 1 | 1.525 | | | |
| 0 | 0 | 0 | 0 | 1 | 0 | 1.500 | | | |
| 0 | 0 | 0 | 0 | 1 | 1 | 1.475 | | | |
| 0 | 0 | 0 | 1 | 0 | 0 | 1.450 | | | |
| 0 | 0 | 0 | 1 | 1 | 0 | 1.425 | | | |
| 0 | 0 | 0 | 1 | 1 | 1 | 1.400 | | | |
| 0 | 0 | 1 | 0 | 0 | 0 | 1.375 | | | |
| 0 | 0 | 1 | 0 | 0 | 1 | 1.350 | | | |
| 0 | 0 | 1 | 0 | 1 | 0 | 1.325 | | | |
| 0 | 0 | 1 | 0 | 1 | 1 | 1.300 | | | |
| 0 | 0 | 1 | 1 | 0 | 0 | 1.275 | | | |
| 0 | 0 | 1 | 1 | 0 | 1 | 1.250 | | | |
| 0 | 0 | 1 | 1 | 1 | 0 | 1.225 | | | |
| 0 | 0 | 1 | 1 | 1 | 1 | 1.200 | | | |
| 0 | 1 | 0 | 0 | 0 | 0 | 1.175 | | | |
| 0 | 1 | 0 | 0 | 0 | 1 | 1.150 | | | |
| 0 | 1 | 0 | 0 | 1 | 0 | 1.125 | | | |
| 0 | 1 | 0 | 0 | 1 | 1 | 1.100 | | | |
| 0 | 1 | 0 | 1 | 0 | 0 | 1.075 | | | |
| 0 | 1 | 0 | 1 | 0 | 1 | 1.050 | | | |
| 0 | 1 | 0 | 1 | 1 | 0 | 1.025 | | | |
| 0 | 1 | 1 | 0 | 0 | 0 | 1.000 | | | |
| 0 | 1 | 1 | 0 | 0 | 1 | 0.975 | | | |
| 0 | 1 | 1 | 0 | 1 | 0 | 0.950 | | | |
| 0 | 1 | 1 | 0 | 1 | 1 | 0.925 | | | |
| 0 | 1 | 1 | 1 | 0 | 0 | 0.900 | | | |
| 0 | 1 | 1 | 1 | 0 | 1 | 0.875 | | | |
| 0 | 1 | 1 | 1 | 1 | 0 | 0.850 | | | |
| 0 | 1 | 1 | 1 | 1 | 1 | 0.825 | | | |
| 1 | 0 | 0 | 0 | 0 | 0 | 0.800 | | | |
| 1 | 0 | 0 | 0 | 0 | 1 | 0.775 | | | |
| 1 | 0 | 0 | 0 | 1 | 0 | 0.750 | | | |
| 1 | 0 | 0 | 0 | 1 | 1 | 0.725 | | | |
| 1 | 0 | 0 | 1 | 0 | 0 | 0.700 | | | |
| 1 | 0 | 0 | 1 | 0 | 1 | 0.675 | | | |
| 1 | 0 | 1 | 0 | 0 | 0 | 0.650 | | | |
| 1 | 0 | 1 | 0 | 0 | 1 | 0.625 | | | |
| 1 | 0 | 1 | 0 | 1 | 0 | 0.600 | | | |
| 1 | 0 | 1 | 0 | 1 | 1 | 0.575 | | | |
| 1 | 1 | 0 | 0 | 0 | 0 | 0.550 | | | |
| 1 | 1 | 0 | 0 | 0 | 1 | 0.525 | | | |
| 1 | 1 | 0 | 0 | 1 | 0 | 0.500 | | | |
| 1 | 1 | 0 | 0 | 1 | 1 | 0.475 | | | |
| 1 | 1 | 0 | 1 | 0 | 0 | 0.450 | | | |
| 1 | 1 | 0 | 1 | 0 | 1 | 0.425 | | | |
| 1 | 1 | 0 | 1 | 1 | 0 | 0.400 | | | |
| 1 | 1 | 0 | 1 | 1 | 1 | 0.375 | | | |

CPU_VCORE
 VID=1.20V (25W) / 1.15V (35W)
 Iomax=21A (25W) / 35A (35W)
 OCP=40A~45A

Place close to L30

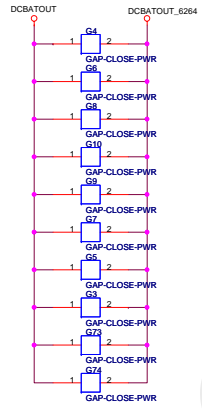
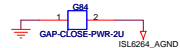

VCC_CORE_S0

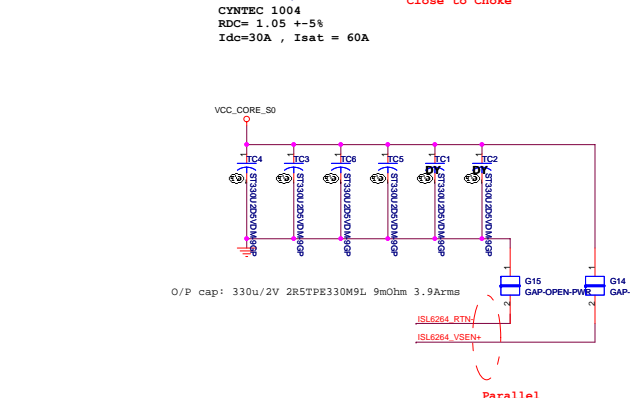
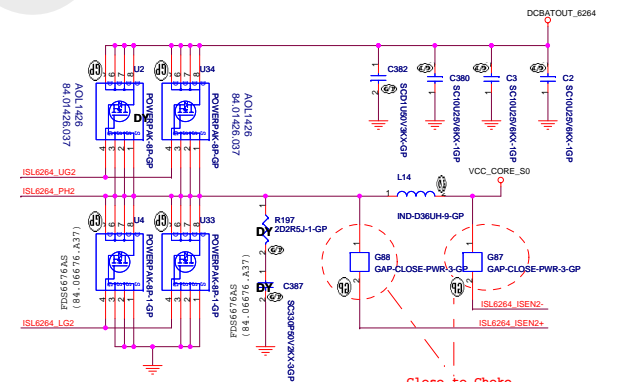
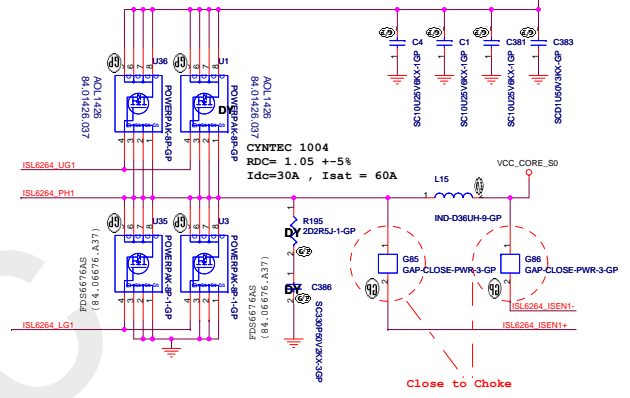

O/P cap: 330u/2V 2R5TPB330M9L 9mOhm 3.9Arms

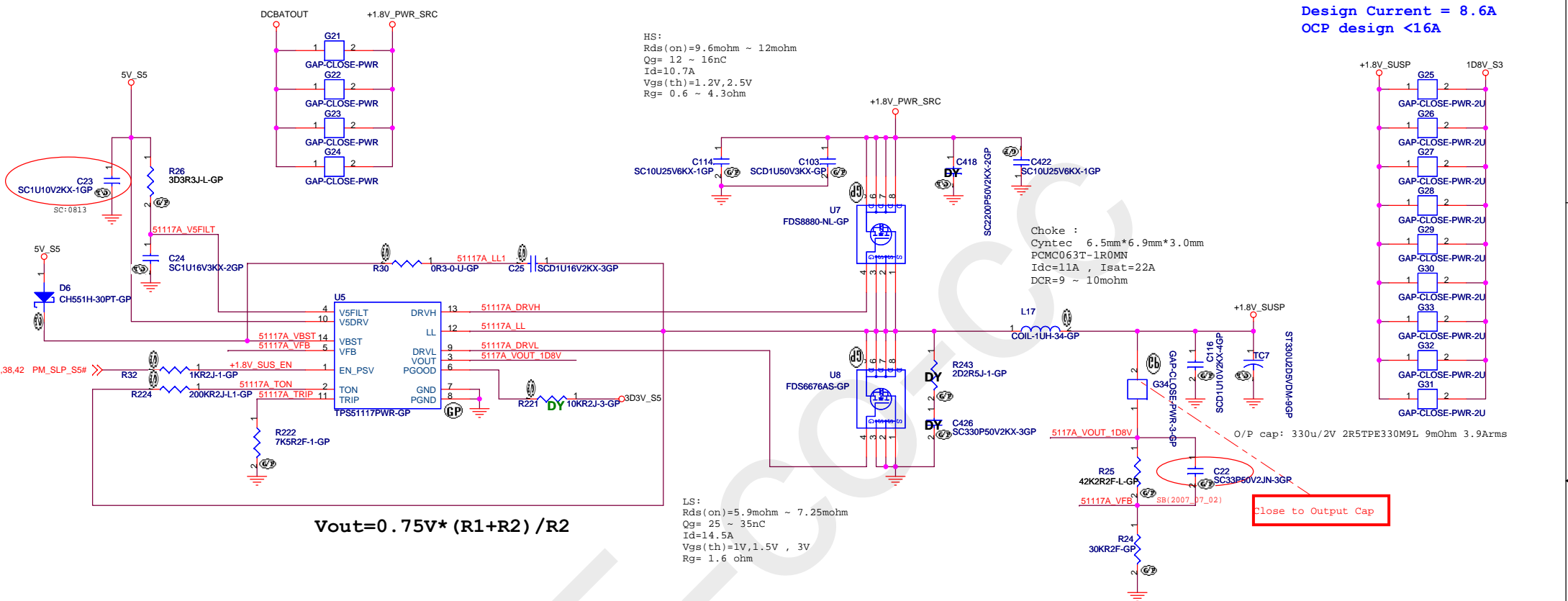

Design Current = 8.6A
 OCP design <16A

HS:
 Rds(on)=9.6mohm ~ 12mohm
 Qg= 12 ~ 16nC
 Id=10.7A
 Vgs(th)=1.2V, 2.5V
 Rg= 0.6 ~ 4.3ohm

Choke :
 Cyntec 6.5mm*6.9mm*3.0mm
 PCMC063T-1ROMN
 Idc=11A , Isat=22A
 DCR=9 ~ 10mohm

LS:
 Rds(on)=5.9mohm ~ 7.25mohm
 Qg= 25 ~ 35nC
 Id=14.5A
 Vgs(th)=1V, 1.5V , 3V
 Rg= 1.6 ohm

$$V_{out} = 0.75V * (R1 + R2) / R2$$

O/P cap: 330u/2V 2R5TPE330M9L 9mOhm 3.9Arms
 Close to Output Cap

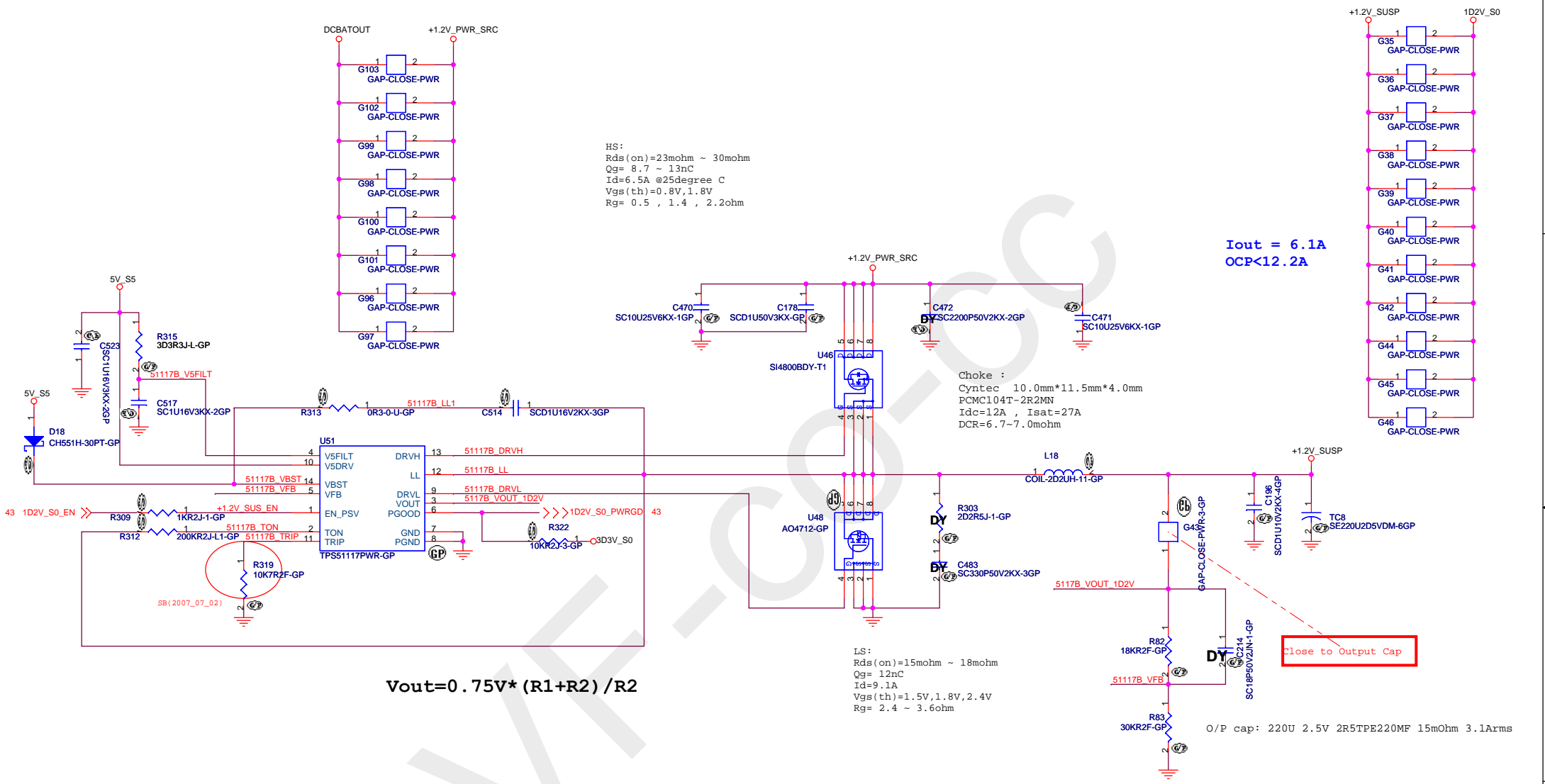

HS:
 Rds(on)=23mohm ~ 30mohm
 Qg= 8.7 ~ 13nC
 Id=6.5A @25degree C
 Vgs(th)=0.8V, 1.8V
 Rg= 0.5 , 1.4 , 2.2ohm

Iout = 6.1A
 OCP<12.2A

Choke :
 Cyntec 10.0mm*11.5mm*4.0mm
 PCMC104T-2R2MN
 Idc=12A , Isat=27A
 DCR=6.7~7.0mohm

LS:
 Rds(on)=15mohm ~ 18mohm
 Qg= 12nC
 Id=9.1A
 Vgs(th)=1.5V, 1.8V, 2.4V
 Rg= 2.4 ~ 3.6ohm

$$V_{out} = 0.75V * (R1 + R2) / R2$$

O/P cap: 220U 2.5V 2R5TPE220MF 15mOhm 3.1Arms

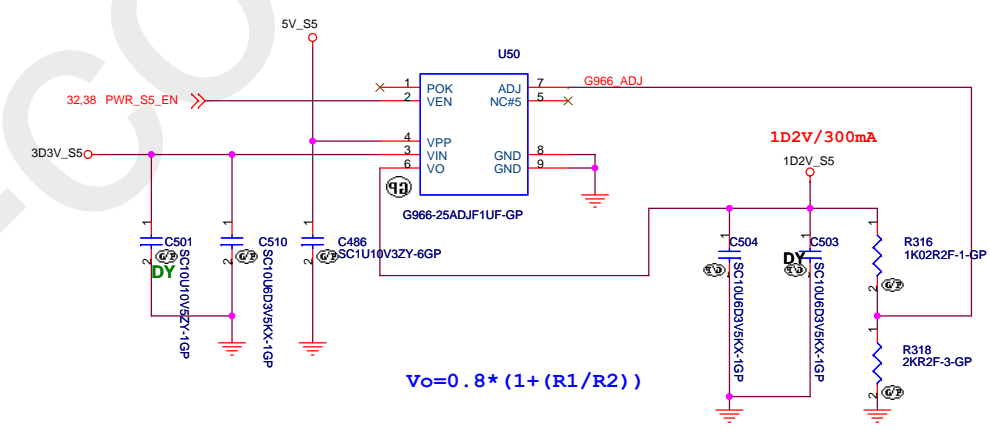
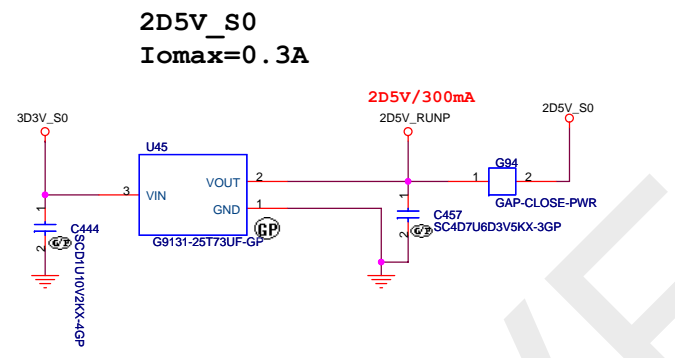
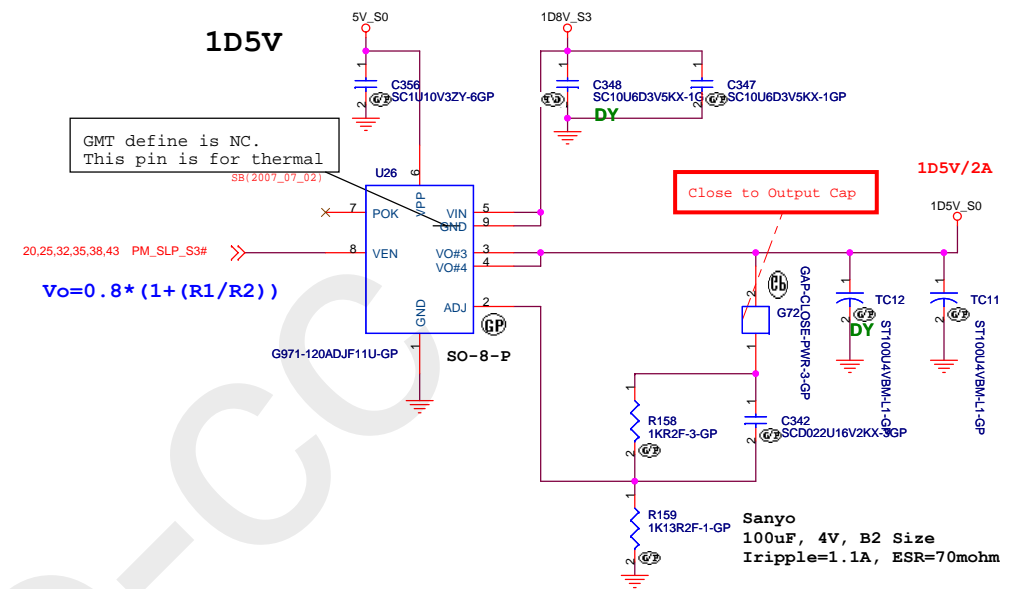
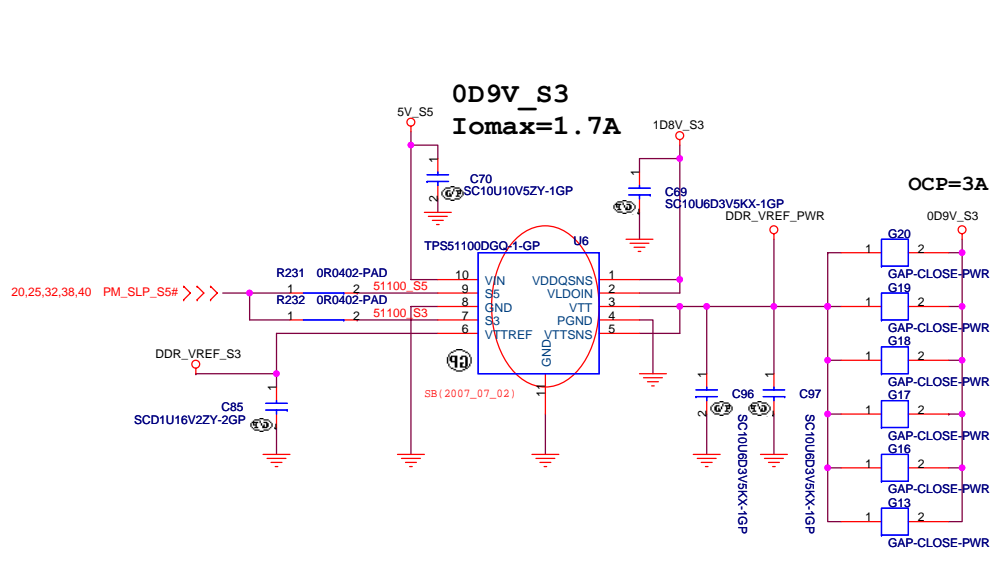

Run Power

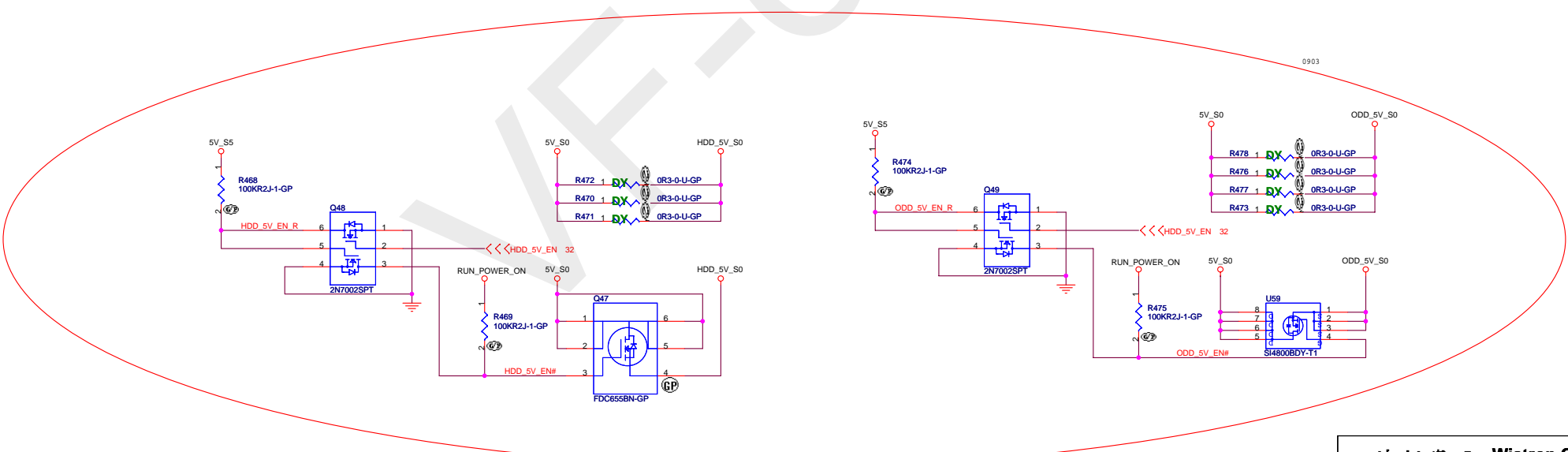
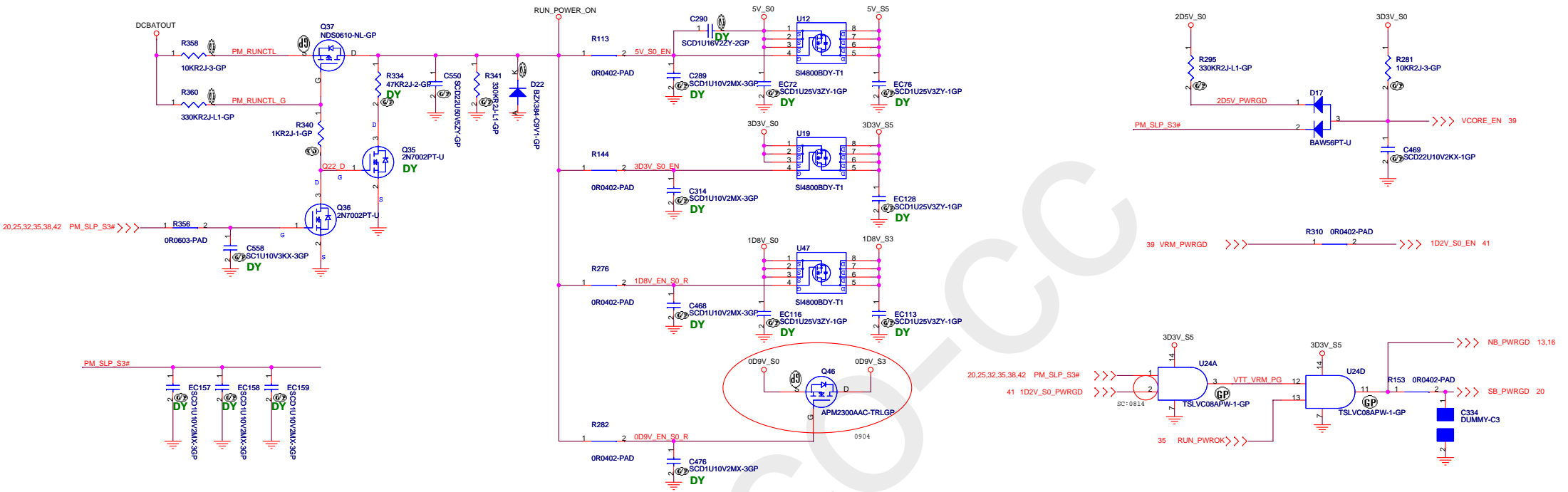

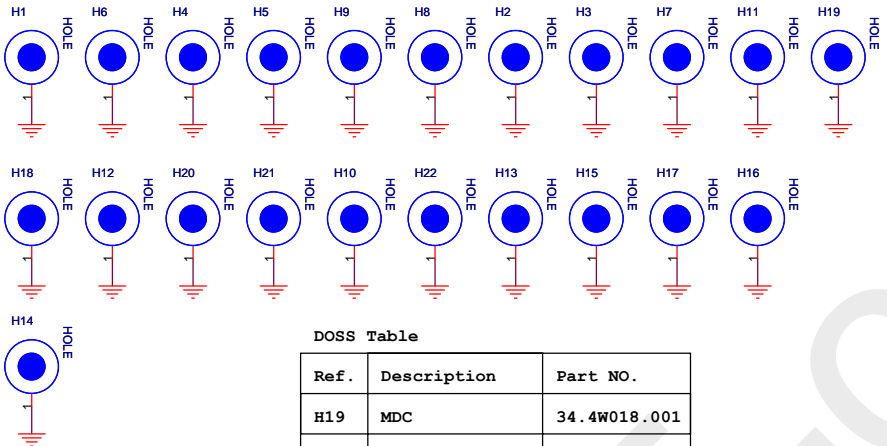
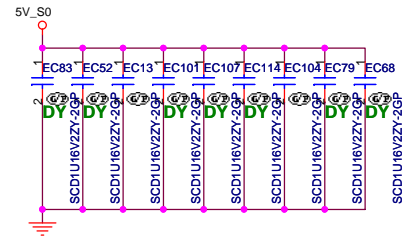
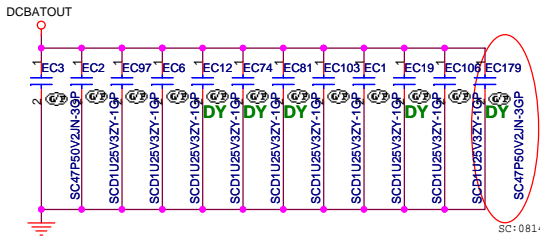
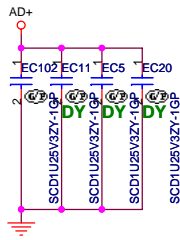
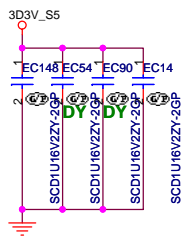
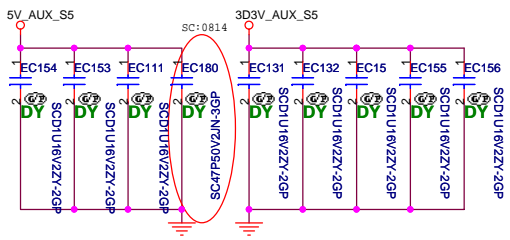

DOSS Table

| Ref. | Description | Part NO. |
|------|-------------|--------------|
| H19 | MDC | 34.4W018.001 |
| H20 | Mini Card | 34.4W005.001 |
| H21 | Mini Card | 34.4W005.001 |
| H22 | Mini Card | 34.4W005.001 |
| H18 | Heat sink | 34.4A908.001 |
| H15 | New Card | 34.4W004.001 |

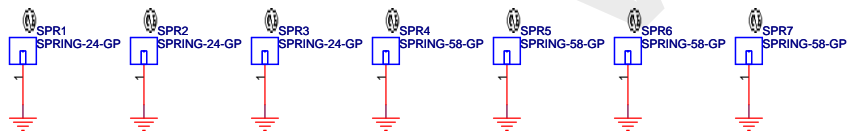
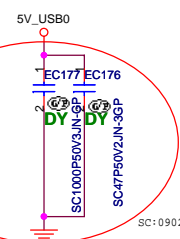
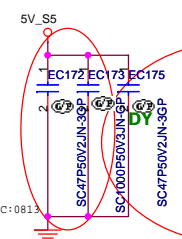
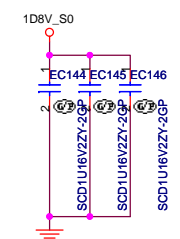
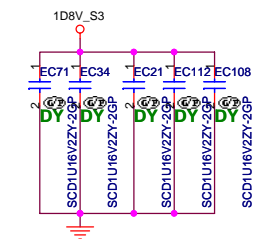
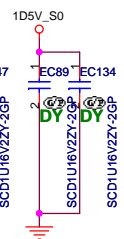
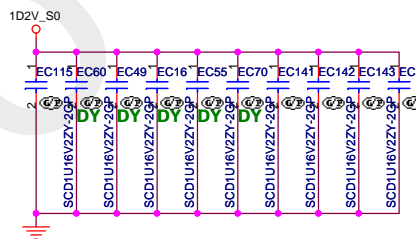
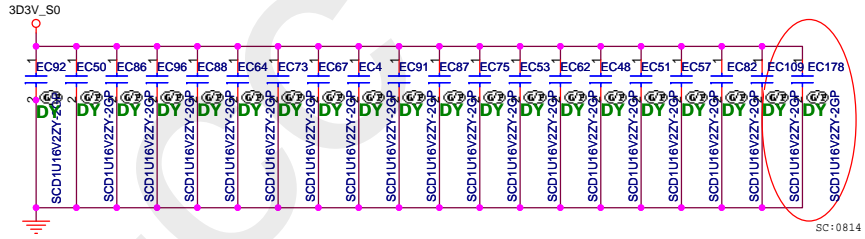

緯創資通 Wistron Corporation
 21F, 88, Sec.1, Hsin Tai Wu Rd., Hsichih, Taipei Hsien 221, Taiwan, R.O.C.

Title: **MISC**

Size A3 Document Number: **DS2-AMD** Rev: **1**

Date: Monday, September 24, 2007 Sheet 44 of 44