

COMPAL CONFIDENTIAL

MODEL NAME : *HAL00*

PCB NO : *LA-2792*

COMPAL P/N : *45135731L01*

Travis (DIS) Schematics Document

**uFCPGA Mobile Yonah
Intel Calistoga + ICH7M**

2006-02-09

REV : 1.0 (DELL: A00)

MB PCB

Part Number	Description
DAA0000051L	PCB ZJX LA-2792P REV1 MB DIS

BOM NO. 45135731L01

PCB P/N: DAA0000051L

PROPRIETARY NOTE: THIS SHEET OF ENGINEERING DRAWING AND SPECIFICATIONS CONTAINS CONFIDENTIAL TRADE SECRET AND OTHER PROPRIETARY INFORMATION OF DELL INC. ("DELL") THIS DOCUMENT MAY NOT BE TRANSMITTED OR COPIED WITHOUT THE EXPRESS WRITTEN AUTHORIZATION OF DELL. IN ADDITION, NEITHER THIS SHEET NOR THE INFORMATION IT CONTAINS MAY BE USED BY OR DISCLOSED TO ANY THIRD PARTY WITHOUT DELL'S EXPRESS WRITTEN CONSENT.

DELL CONFIDENTIAL/PROPRIETARY



Compal Electronics, Inc.			
Title		Cover Sheet	
Size	Document Number	Rev	
	LA-2792	1.0	
Date:	Thursday, February 09, 2006	Sheet	1 of 70

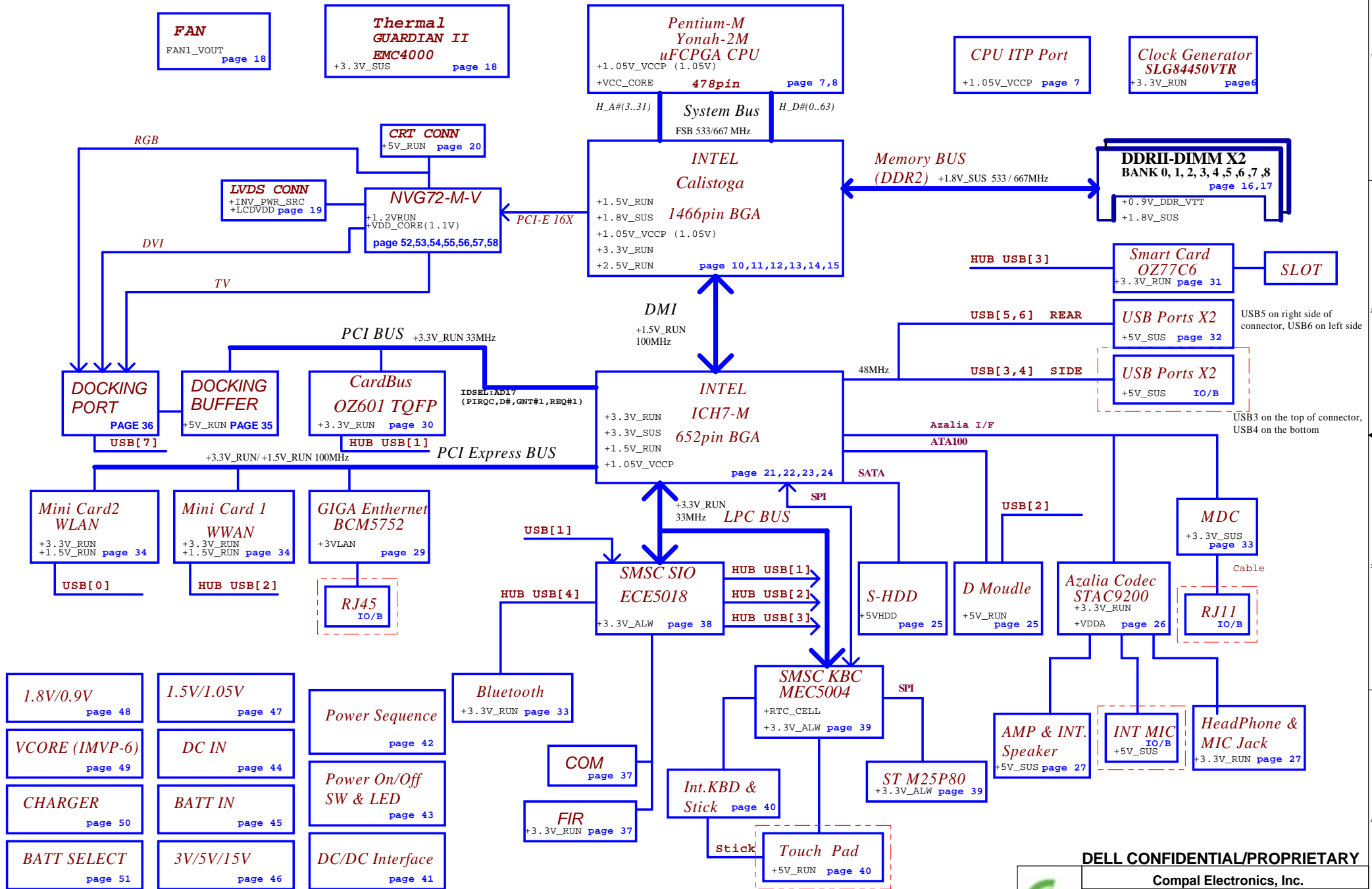

DELL CONFIDENTIAL/PROPRIETARY

Compal Electronics, Inc.

Title: Block Diagram

Size: Document Number

LA-2792

Date: Thursday, February 08, 2006 Sheet 2 of 70 Rev 1.0

Ceramic Capacitors :

0.1U_0402_6.3VXX

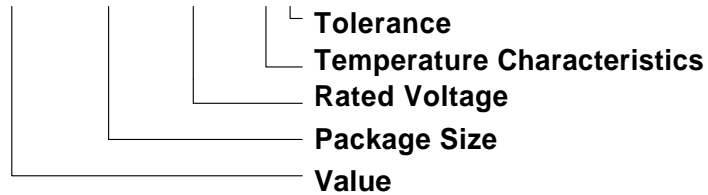

Tantalum or Polymer Capacitors :

10U_D2_10VX_R45

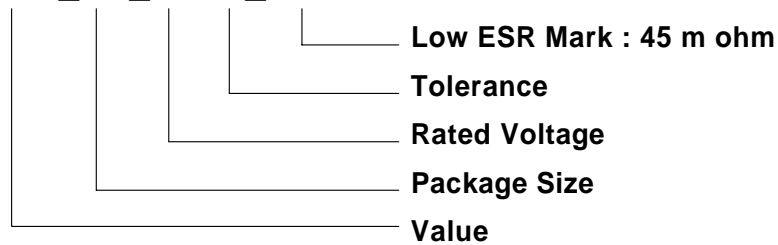

Capacitor Spec Guide:

Temperature Characteristics:

Symbol	0	1	2	3	4	5	6	7
CODE	Z5U	Z5V	Z5P	Y5U	Y5V	Y5P	X5R	X7R

8	9	A	B	C	D	E	F	G
NPO	COG	X6S	BJ	CH	CJ	CK	SH	SJ

H	I	J	K
UJ	UK	SL	X5S

Tolerance:

Symbol	A	B	C	D	F	G	H	J
CODE	+0.05PF	+0.1PF	+0.25PF	+0.5PF	+1PF	+2%	+3%	+5%

K	M	N	P	Q	V	X	Z	
+10%	+20%	+30%	+100,-0%	+30,-10%	+20,-10%	+40,-20%	+80,-20%	

NOTE1:

@XX : Depop component

PCI TABLE

PCI DEVICE	IDSEL	REQ#/GNT#	PIRQ
CARD BUS	AD17	1	C

PM TABLE

power plane / State	+5V_ALW +3.3V_ALW	+3.3V_SRC +15V_SUS +5V_SUS +3.3V_SUS +1.8V_SUS	+5V_RUN +3.3V_RUN +1.8V_RUN +0.9V_DDR_VTT +1.5V_RUN +VCC_CORE +1.05V_VCCP +2.5V_RUN
S0	ON	ON	ON
S1	ON	ON	ON
S3	ON	ON	OFF
S5 S4/AC	ON	OFF	OFF
S5 S4/AC don't exist	OFF	OFF	OFF

USB TABLE

USB PORT#	DESTINATION
0	Mini 2(WLAN)
1	USB Hub (5018)
2	D Moudle
3,4	SIDE
5,6	REAR
7	Docking

USB HUB	DESTINATION
1	PC Card Bay
2	Mini 1(WWAN)
3	Smart Card --> BIO
4	Blue tooth

PROPRIETARY NOTE: THIS SHEET OF ENGINEERING DRAWING AND SPECIFICATIONS CONTAINS CONFIDENTIAL TRADE SECRET AND OTHER PROPRIETARY INFORMATION OF DELL INC. ("DELL"). THIS DOCUMENT MAY NOT BE TRANSMITTED OR COPIED WITHOUT THE EXPRESS WRITTEN AUTHORIZATION OF DELL. IN ADDITION, NEITHER THIS SHEET NOR THE INFORMATION IT CONTAINS MAY BE USED BY OR DISCLOSED TO ANY THIRD PARTY WITHOUT DELL'S EXPRESS WRITTEN CONSENT.



DELL CONFIDENTIAL/PROPRIETARY

Compal Electronics, Inc.

Index and Config.		
Title		
Size	Document Number	Rev
	LA-2792	1.0
Date:	Thursday, February 09, 2006	Sheet 3 of 70

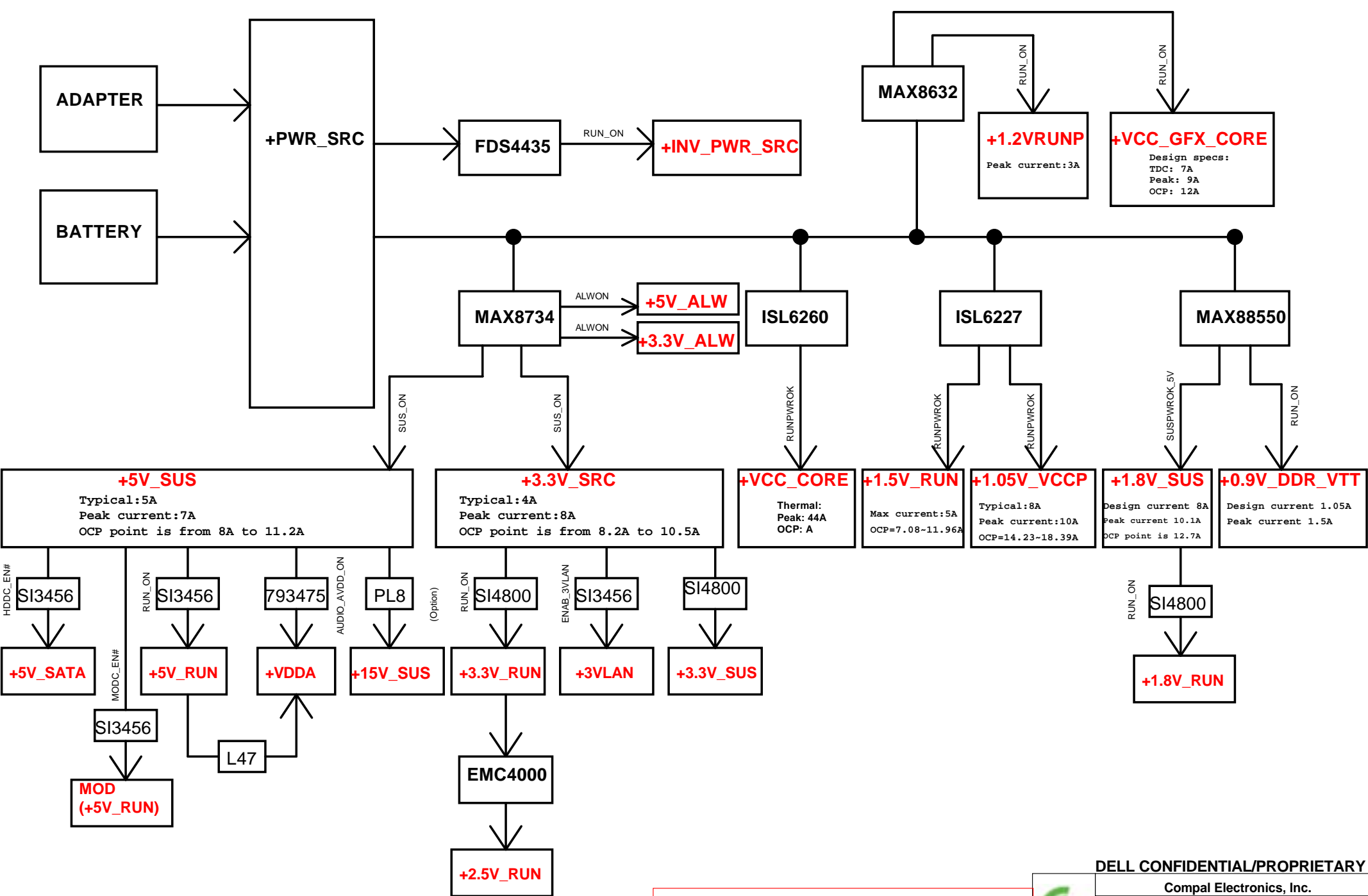

PROPRIETARY NOTE: THIS SHEET OF ENGINEERING DRAWING AND SPECIFICATIONS CONTAINS CONFIDENTIAL TRADE SECRET AND OTHER PROPRIETARY INFORMATION OF DELL INC. ("DELL"). THIS DOCUMENT MAY NOT BE TRANSFERRED OR COPIED WITHOUT THE EXPRESS WRITTEN AUTHORIZATION OF DELL. IN ADDITION, NEITHER THIS SHEET NOR THE INFORMATION IT CONTAINS MAY BE USED BY OR DISCLOSED TO ANY THIRD PARTY WITHOUT DELL'S EXPRESS WRITTEN CONSENT.



DELL CONFIDENTIAL/PROPRIETARY

Compal Electronics, Inc.

Title			Power Rail		
Size	Document Number	Rev			
	LA-2792	1.0			
Date:	Thursday, February 09, 2006	Sheet	4	of	70

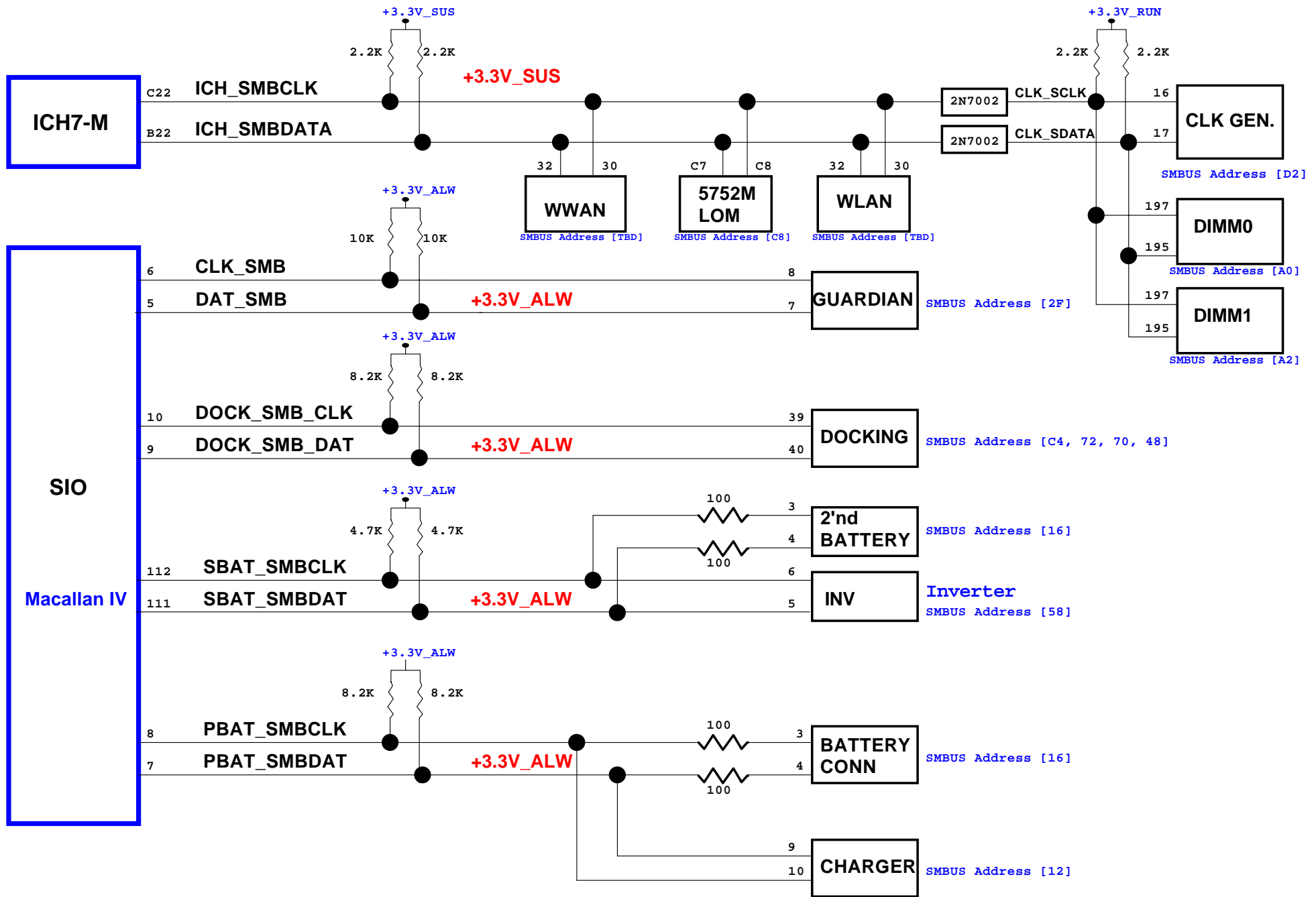

PROPRIETARY NOTE: THIS SHEET OF ENGINEERING DRAWING AND SPECIFICATIONS CONTAINS CONFIDENTIAL TRADE SECRET AND OTHER PROPRIETARY INFORMATION OF DELL INC. ("DELL"). THIS DOCUMENT MAY NOT BE TRANSMITTED OR COPIED WITHOUT THE EXPRESS WRITTEN AUTHORIZATION OF DELL. IN ADDITION, NEITHER THIS SHEET NOR THE INFORMATION IT CONTAINS MAY BE USED BY OR DISCLOSED TO ANY THIRD PARTY WITHOUT DELL'S EXPRESS WRITTEN CONSENT.



DELL CONFIDENTIAL/PROPRIETARY

Compal Electronics, Inc.

Title			SMBUS TOPOLOGY		
Size	Document Number	Rev			
	LA-2792	1.0			
Date:	Thursday, February 09, 2006	Sheet	5	of	70

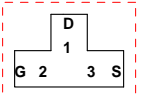

2N7002



FSC	FSB	FSA	CPU	SRC	PCI
CLKSEL2	CLKSEL1	CLKSEL0	MHz	MHz	MHz
0	0	0	266	100	33.3
0	0	1	133	100	33.3
0	1	0	200	100	33.3
0	1	1	166	100	33.3
1	0	0	333	100	33.3
1	0	1	100	100	33.3
1	1	0	400	100	33.3
1	1	1			Reserve

Table : ICS954305AK

CPU_BSEL	CPU_BSEL2 (FSC)	CPU_BSEL1 (FSB)
133	0	0
166	0	1

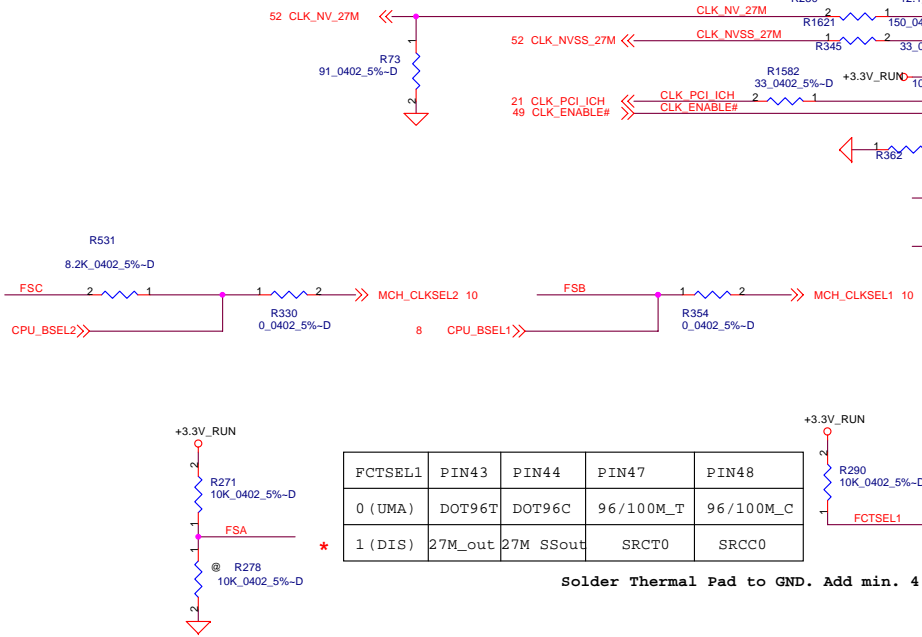

FCTSEL1	PIN43	PIN44	PIN47	PIN48
0 (UMA)	DOT96T	DOT96C	96/100M_T	96/100M_C
1 (DIS)	27M_out	27M SSout	SRCT0	SRCC0

NOTE: Place Decoupling as close as physically possible to the VDD pins

Place crystal within 500 mils of CK410

**Place near each pin
W>40 mil**

Place near CK410+

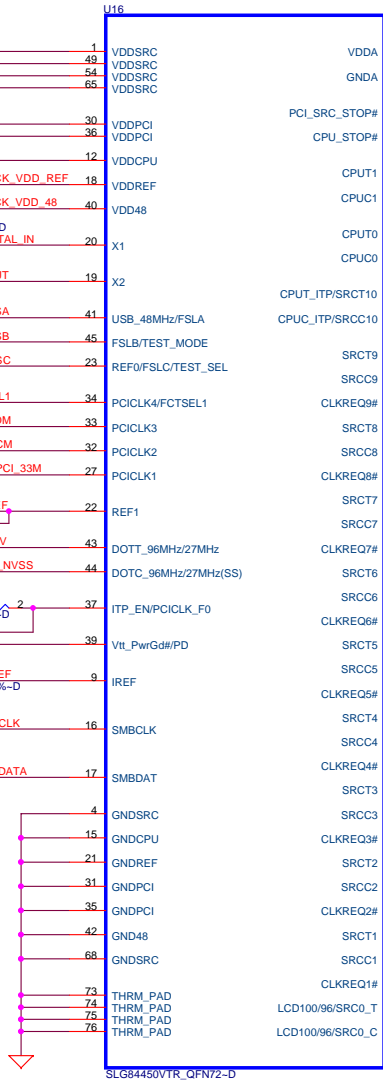

Solder Thermal Pad to GND. Add min. 4 vias.

5.1 PROPRIETARY NOTE: THIS SHEET OF ENGINEERING DRAWING AND SPECIFICATIONS CONTAINS CONFIDENTIAL TRADE SECRET AND OTHER PROPRIETARY INFORMATION OF DELL INC. ("DELL"). THIS DOCUMENT MAY NOT BE TRANSMITTED OR COPIED WITHOUT THE EXPRESS WRITTEN AUTHORIZATION OF DELL. IN ADDITION, NEITHER THIS SHEET NOR THE INFORMATION IT CONTAINS MAY BE USED BY OR DISCLOSED TO ANY THIRD PARTY WITHOUT DELL'S EXPRESS WRITTEN CONSENT.



DELL CONFIDENTIAL/PROPRIETARY

Compal Electronics, Inc.

Clock Generator

Title	Document Number	Rev
	LA-2792	1.0
Date: Thursday, February 09, 2006	Sheet 6 of 70	

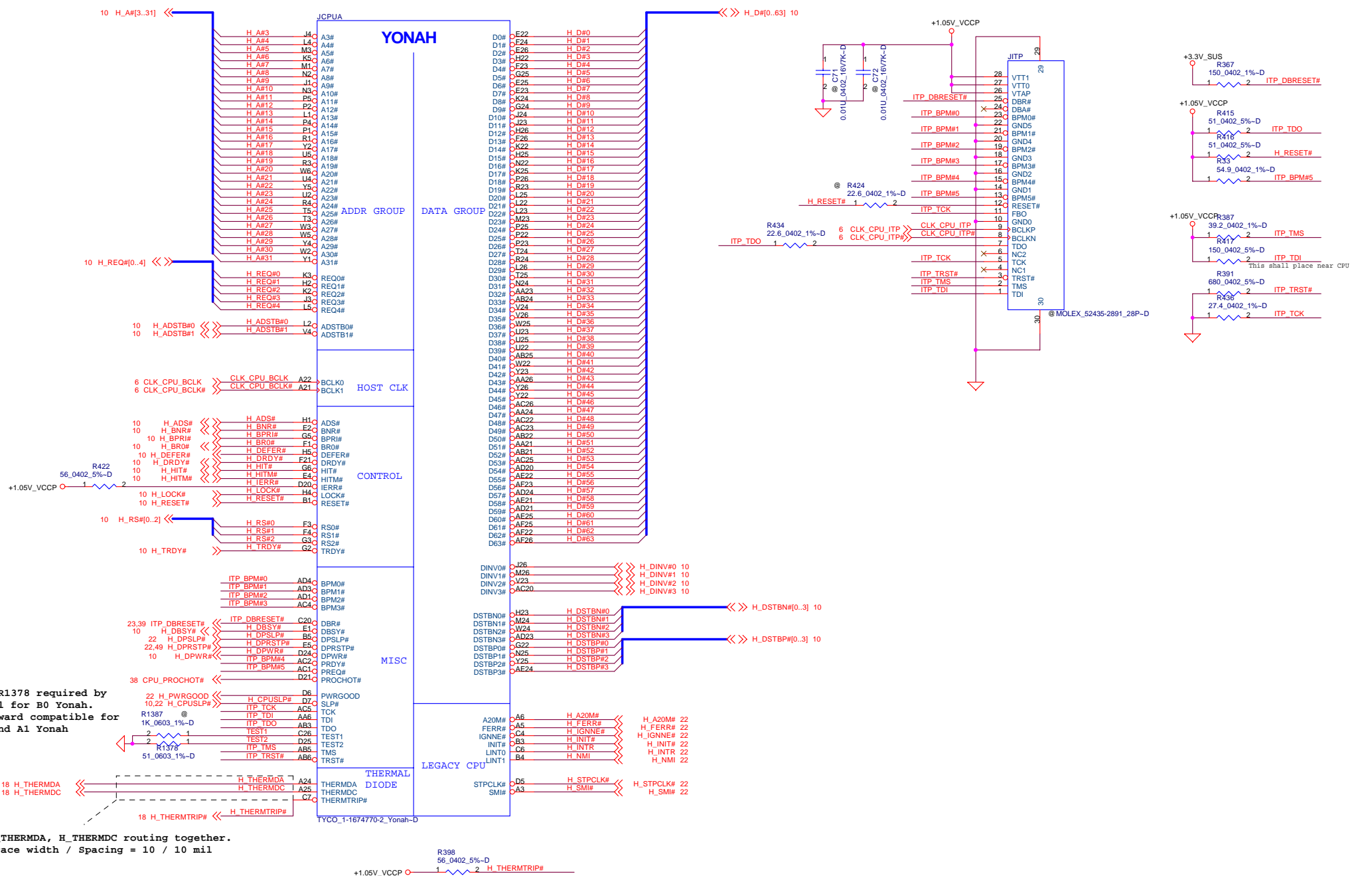

Pop R1378 required by Intel for B0 Yonah. Backward compatible for A0 and A1 Yonah

H_THERMDA, H_THERMDC routing together. Trace width / Spacing = 10 / 10 mil

PROPRIETARY NOTE: THIS SHEET OF ENGINEERING DRAWING AND SPECIFICATIONS CONTAINS CONFIDENTIAL TRADE SECRET AND OTHER PROPRIETARY INFORMATION OF DELL INC. ('DELL'). THIS DOCUMENT MAY NOT BE TRANSMITTED OR COPIED WITHOUT THE EXPRESS WRITTEN AUTHORIZATION OF DELL. IN ADDITION, NEITHER THIS SHEET NOR THE INFORMATION IT CONTAINS MAY BE USED BY OR DISCLOSED TO ANY THIRD PARTY WITHOUT DELL'S EXPRESS WRITTEN CONSENT.



DELL CONFIDENTIAL/PROPRIETARY

Compal Electronics, Inc.

Yonah in mFCPGA479

LA-2792

Thursday, February 09, 2006 Sheet 7 of 70

Length match within 25 mils

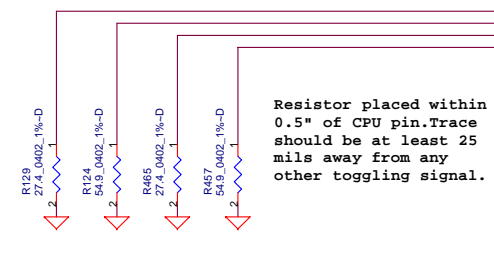
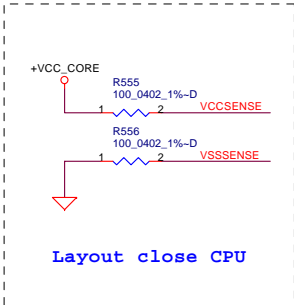
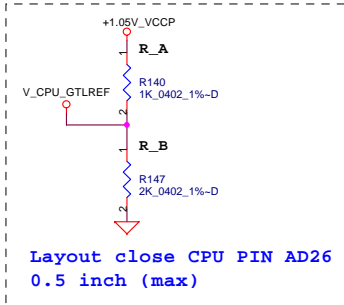

CPU_BSEL	CPU_BSEL2	CPU_BSEL1	CPU_BSEL0
133	0	0	1
166	0	1	1

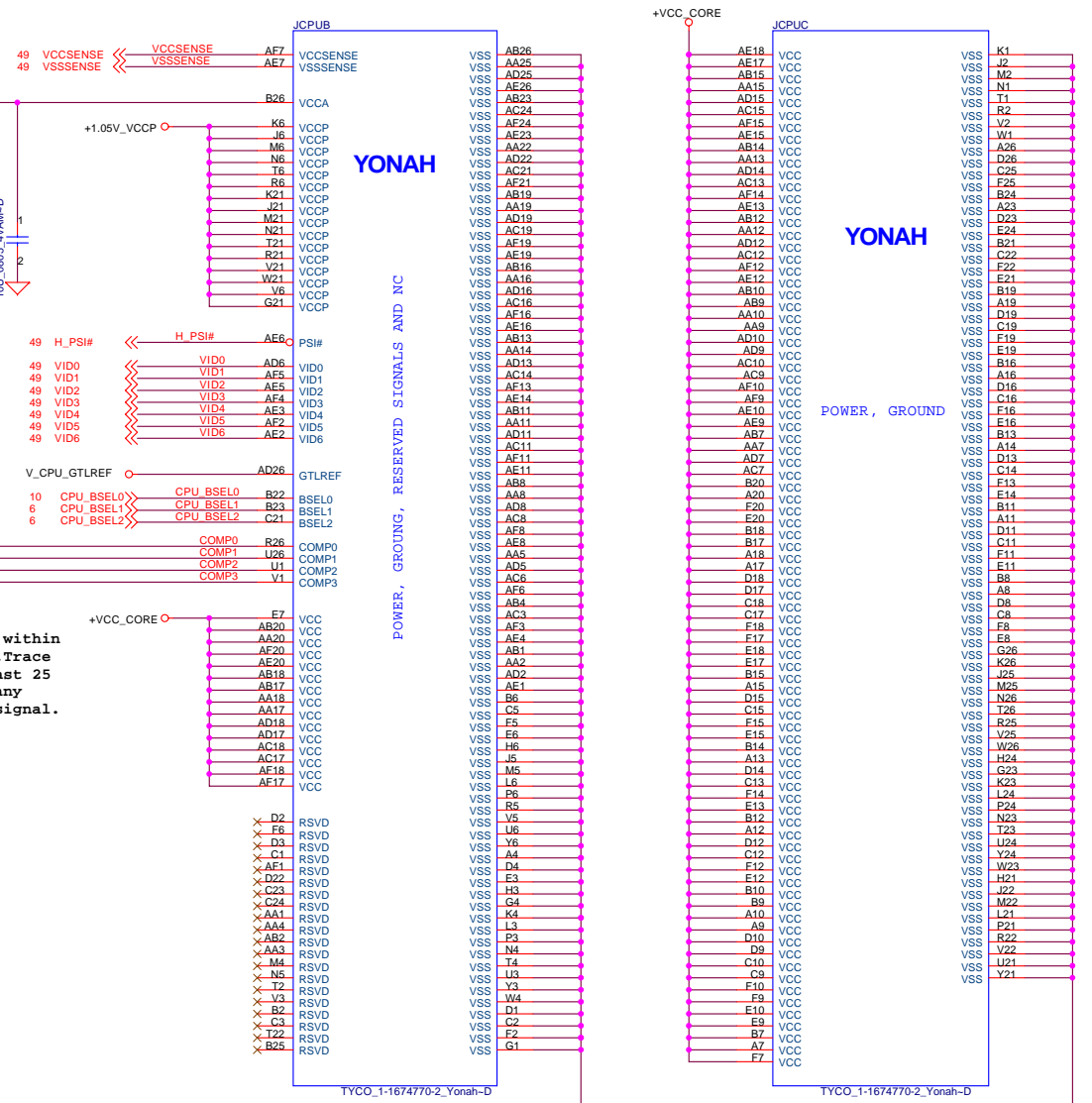

PROPRIETARY NOTE: THIS SHEET OF ENGINEERING DRAWING AND SPECIFICATIONS CONTAINS CONFIDENTIAL TRADE SECRET AND OTHER PROPRIETARY INFORMATION OF DELL INC. ("DELL") THIS DOCUMENT MAY NOT BE TRANSMITTED OR COPIED WITHOUT THE EXPRESS WRITTEN AUTHORIZATION OF DELL. IN ADDITION, NEITHER THIS SHEET NOR THE INFORMATION IT CONTAINS MAY BE USED BY OR DISCLOSED TO ANY THIRD PARTY WITHOUT DELL'S EXPRESS WRITTEN CONSENT.

DELL CONFIDENTIAL/PROPRIETARY
Compal Electronics, Inc.

Title: **Yonah in mFCPGA479**

Size: Document Number
 Date: Thursday, February 09, 2006 Sheet 8 of 70

Rev: 1.0

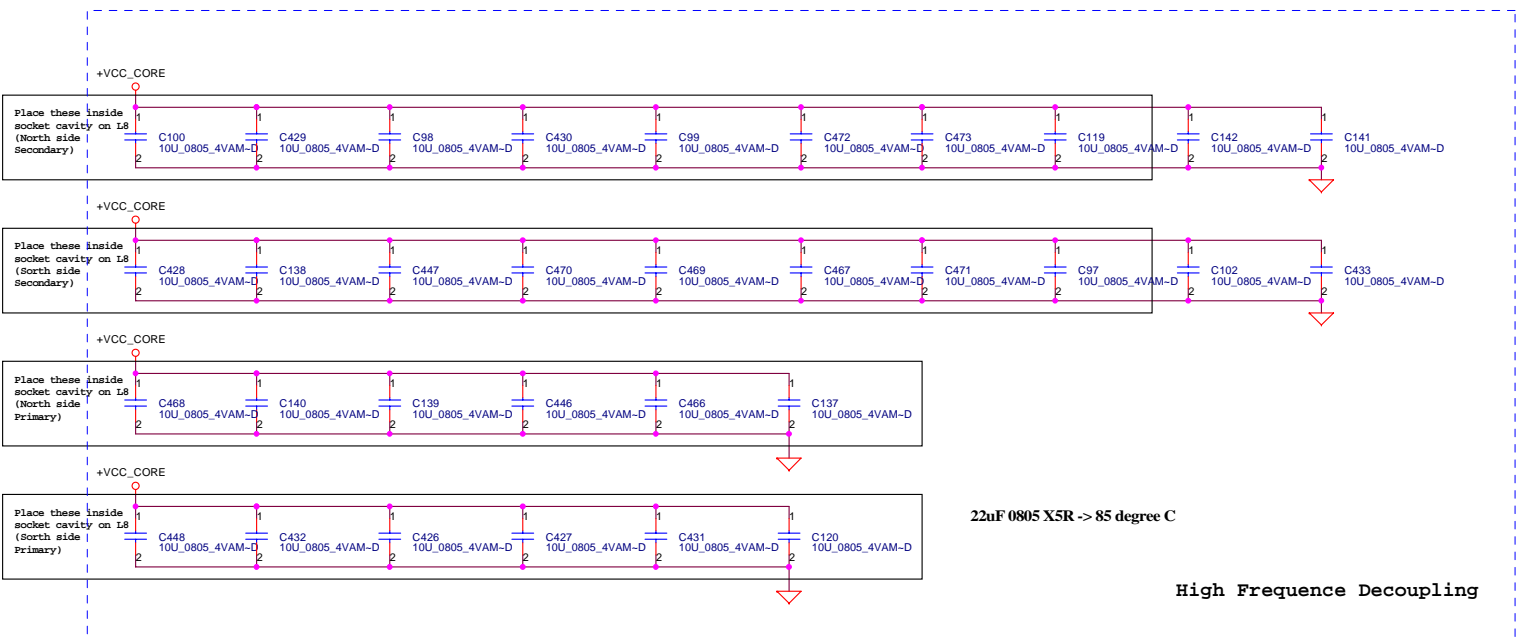

22nF 0805 X5R -> 85 degree C

Near VCORE regulator.

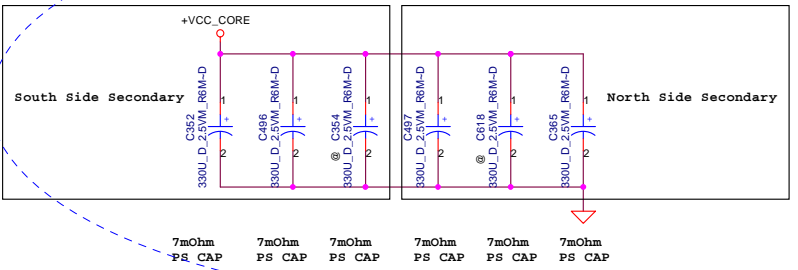

The caps need change to ESR=6m ohms

ESR <= 1.5m ohm
Capacitor > 1980uF

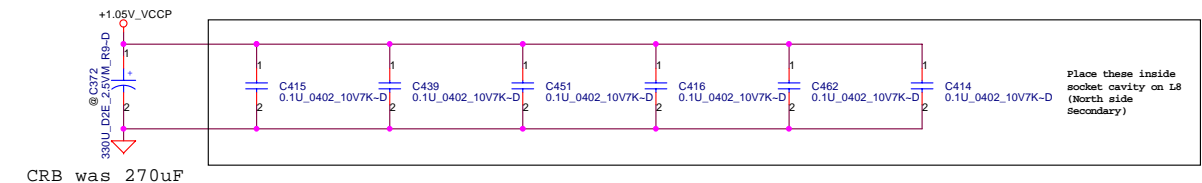

CRB was 270uF

PROPRIETARY NOTE: THIS SHEET OF ENGINEERING DRAWING AND SPECIFICATIONS CONTAINS CONFIDENTIAL TRADE SECRET AND OTHER PROPRIETARY INFORMATION OF DELL INC. ('DELL'). THIS DOCUMENT MAY NOT BE TRANSFERRED OR COPIED WITHOUT THE EXPRESS WRITTEN AUTHORIZATION OF DELL. IN ADDITION, NEITHER THIS SHEET NOR THE INFORMATION IT CONTAINS MAY BE USED BY OR DISCLOSED TO ANY THIRD PARTY WITHOUT DELL'S EXPRESS WRITTEN CONSENT.

DELL CONFIDENTIAL/PROPRIETARY

Compal Electronics, Inc.

CPU Bypass

LA-2792

Thursday, February 09, 2006 Sheet 9 of 70

Description at page12

Note :
CFG3:17 has
internal pullup,
CFG18:19 has
internal pulldown

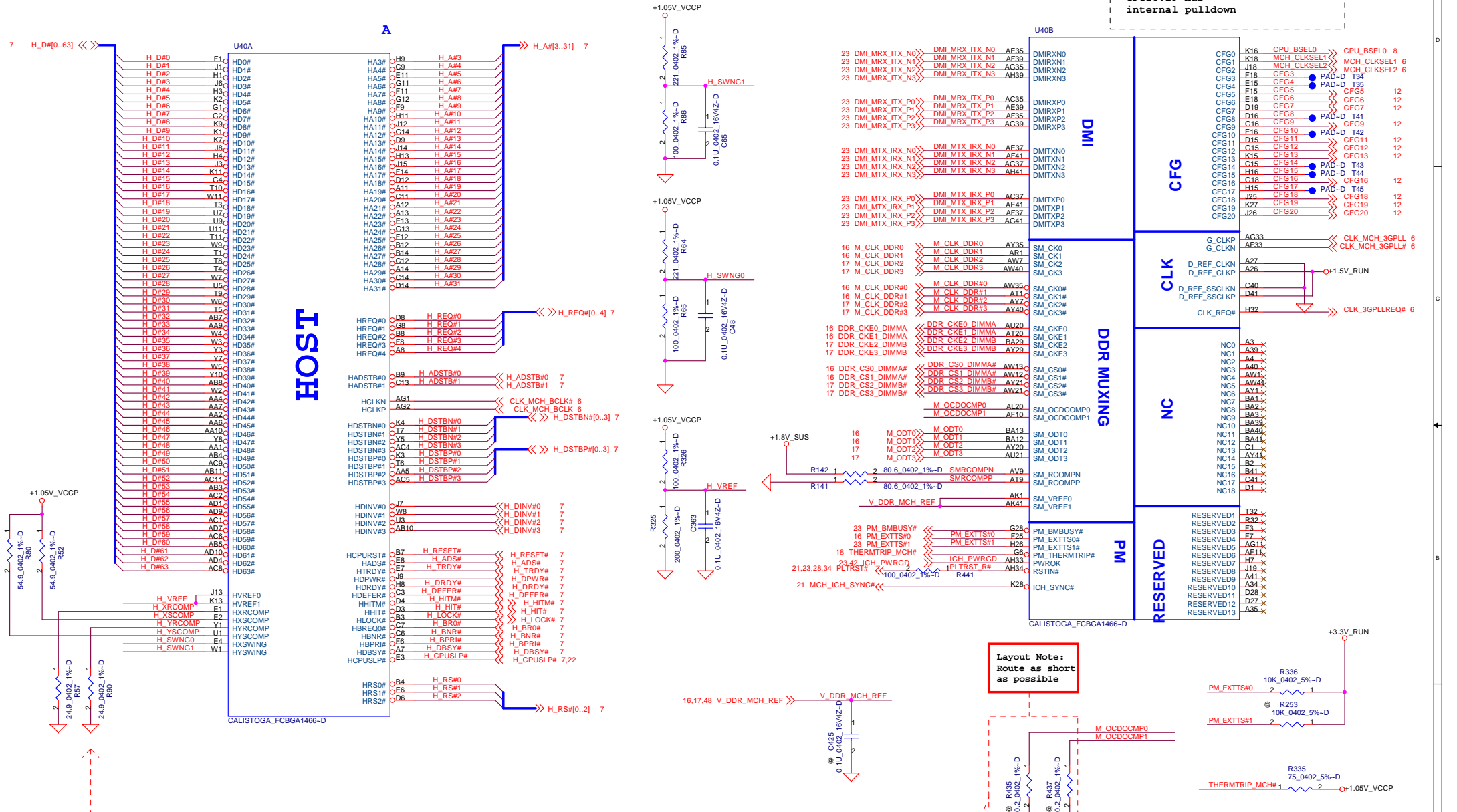

HOST

Layout Note:
Route as short
as possible

Stuff R435 & R437 for A1 Calistoga

Layout Note:
H_XRCOMP & H_YRCOMP trace width
and spacing is 10/20

PROPRIETARY NOTE: THIS SHEET OF ENGINEERING DRAWINGS AND SPECIFICATIONS CONTAINS CONFIDENTIAL TRADE SECRET AND OTHER PROPRIETARY INFORMATION OF DELL, INC. ("DELL"). THIS DOCUMENT MAY NOT BE TRANSMITTED OR COPIED WITHOUT THE EXPRESS WRITTEN AUTHORIZATION OF DELL. IN ADDITION, NEITHER THIS SHEET NOR THE INFORMATION IT CONTAINS MAY BE USED BY OR DISCLOSED TO ANY THIRD PARTY WITHOUT DELL'S EXPRESS WRITTEN CONSENT.



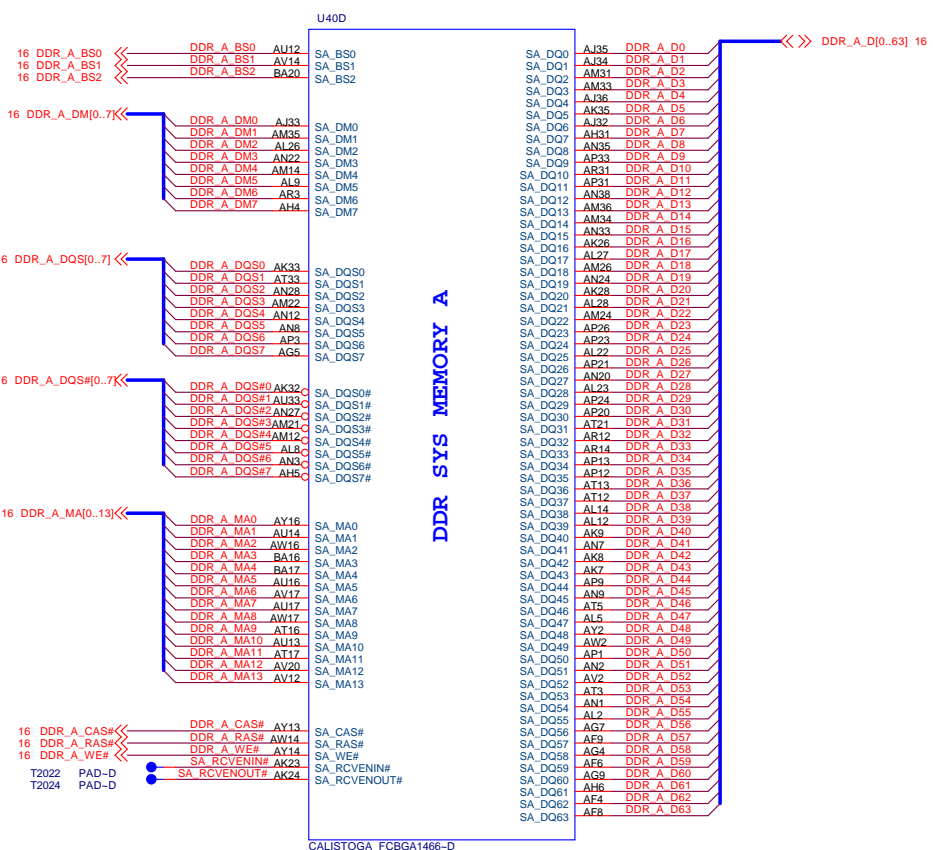

CALISTOGA_FCBGA1466-D

DDR SYS MEMORY A

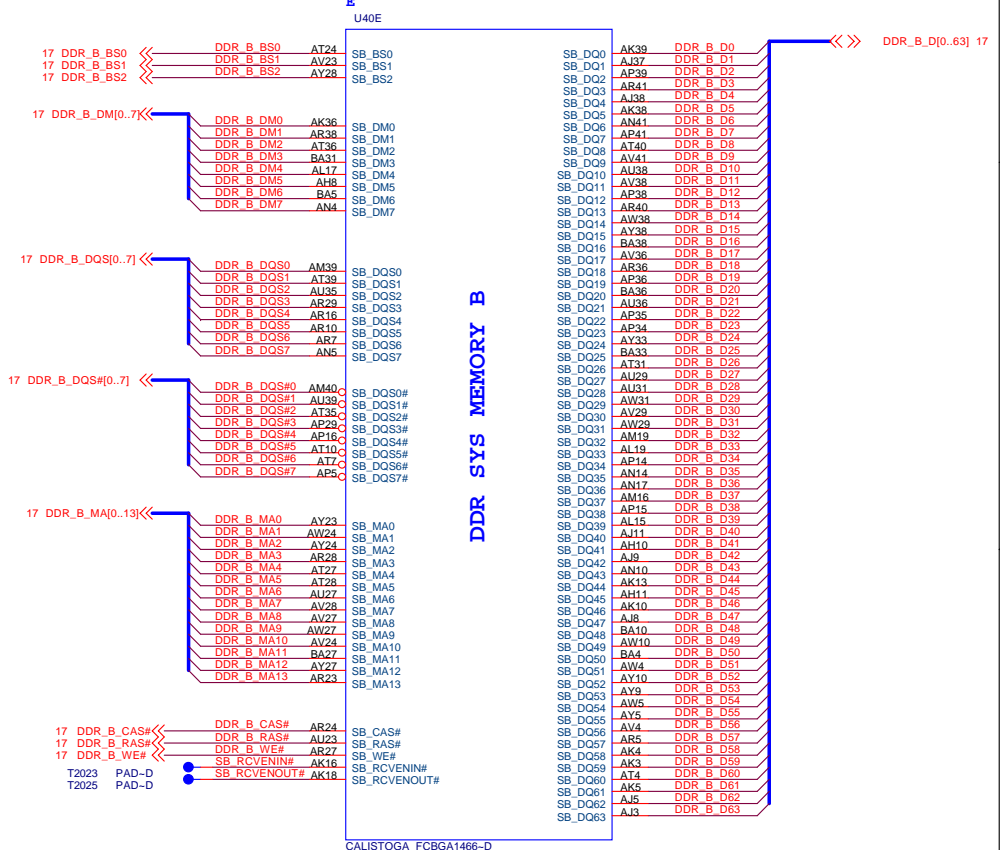

CALISTOGA_FCBGA1466-D

DDR SYS MEMORY B

DELL CONFIDENTIAL/PROPRIETARY

Compal Electronics, Inc.



Title		Calistogo(2 of 6)	
Size	Document Number	Rev	
	LA-2792	1.0	
Date:	Thursday, February 09, 2006	Sheet	11 of 70

PROPRIETARY NOTE: THIS SHEET OF ENGINEERING DRAWING AND SPECIFICATIONS CONTAINS CONFIDENTIAL TRADE SECRET AND OTHER PROPRIETARY INFORMATION OF DELL INC. ("DELL"). THIS DOCUMENT MAY NOT BE TRANSFERRED OR COPIED WITHOUT THE EXPRESS WRITTEN AUTHORIZATION OF DELL. IN ADDITION, NEITHER THIS SHEET NOR THE INFORMATION IT CONTAINS MAY BE USED BY OR DISCLOSED TO ANY THIRD PARTY WITHOUT DELL'S EXPRESS WRITTEN CONSENT.

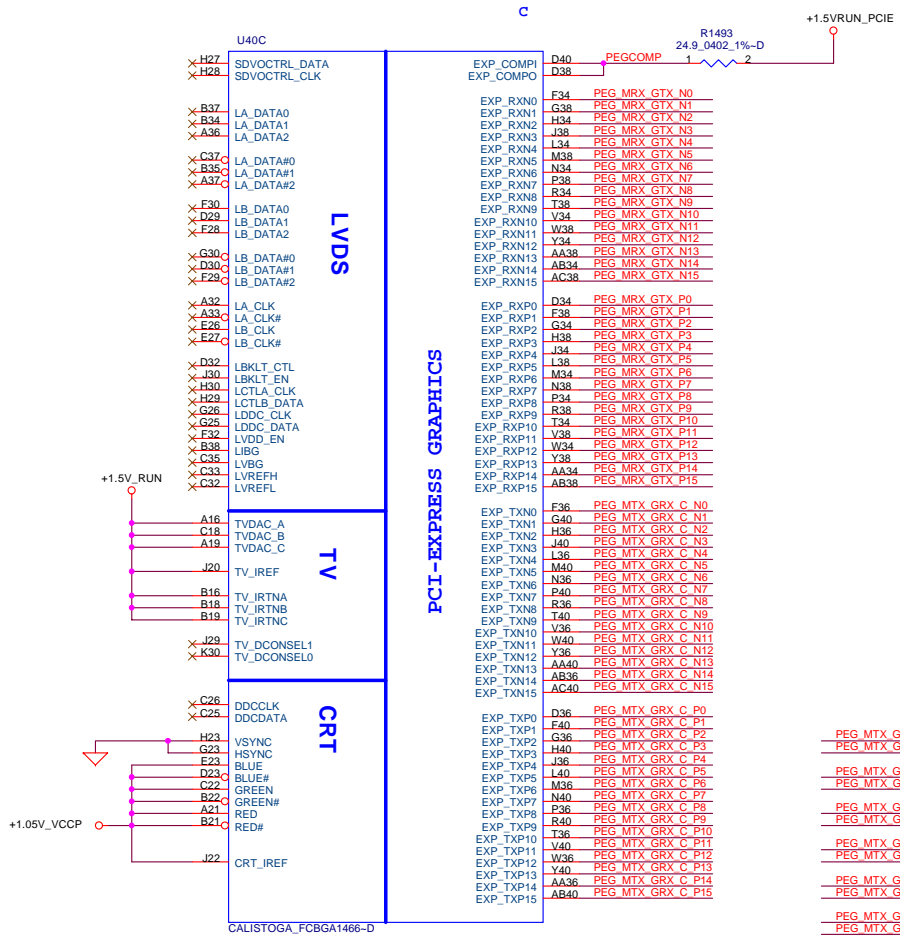

Strap Pin Table

CFG5	Low = DMI x 2 High = DMI x 4 *
CFG6	LOW = Moby Dick HIGH = Calistoga *
CFG7	Low = DT/Transportable CPU High = Mobile CPU *
CFG9	Low = Reverse Lane High = Normal Operation *
CFG11	
CFG[13:12]	00 = Reserved 01 = XOR Mode Enabled 10 = All Z Mode Enabled 11 = Normal Operation * (Default)
CFG16 (FSB Dynamic ODT)	Low = Disabled High = Enabled *
CFG18 (VCC Select)	Low = 1.05V (Default) * High = 1.5V
CFG19 (DMI Lane Reversal)	Low = Normal * Operation (Default): Lane number in Order High = Reverse Lane
SDVO_CTRLDATA	Low = No SDVO Device Present (Default)* High = SDVO Device Present
CFG20 (PCIE/SDVO select)	Low = Only PCIE or SDVO is operational. (Default)* High = PCIE/SDVO are operating simu.

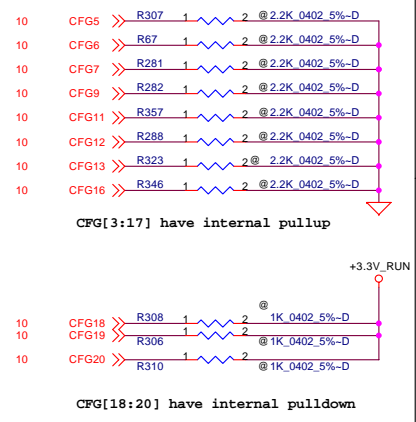

PEG MTX GRX C P0	C1561 ₁	2	0.1U 0402 16V4Z-D	PEG MTX GRX P0	PEG MRX GTX P[0:15]	2	2.2K 0402 5%-D
PEG MTX GRX C N0	C1562 ₁	2	0.1U 0402 16V4Z-D	PEG MTX GRX N0	PEG MRX GTX N[0:15]	2	2.2K 0402 5%-D
PEG MTX GRX C P1	C1563 ₁	2	0.1U 0402 16V4Z-D	PEG MTX GRX P1			
PEG MTX GRX C N1	C1564 ₁	2	0.1U 0402 16V4Z-D	PEG MTX GRX N1			
PEG MTX GRX C P2	C1565 ₁	2	0.1U 0402 16V4Z-D	PEG MTX GRX P2			
PEG MTX GRX C N2	C1566 ₁	2	0.1U 0402 16V4Z-D	PEG MTX GRX N2			
PEG MTX GRX C P3	C1567 ₁	2	0.1U 0402 16V4Z-D	PEG MTX GRX P3			
PEG MTX GRX C N3	C1568 ₁	2	0.1U 0402 16V4Z-D	PEG MTX GRX N3			
PEG MTX GRX C P4	C1569 ₁	2	0.1U 0402 16V4Z-D	PEG MTX GRX P4	PEG MTX GRX P[0:15]	2	2.2K 0402 5%-D
PEG MTX GRX C N4	C1570 ₁	2	0.1U 0402 16V4Z-D	PEG MTX GRX N4	PEG MTX GRX N[0:15]	2	2.2K 0402 5%-D
PEG MTX GRX C P5	C1571 ₁	2	0.1U 0402 16V4Z-D	PEG MTX GRX P5			
PEG MTX GRX C N5	C1572 ₁	2	0.1U 0402 16V4Z-D	PEG MTX GRX N5			
PEG MTX GRX C P6	C1573 ₁	2	0.1U 0402 16V4Z-D	PEG MTX GRX P6			
PEG MTX GRX C N6	C1574 ₁	2	0.1U 0402 16V4Z-D	PEG MTX GRX N6			
PEG MTX GRX C P7	C1575 ₁	2	0.1U 0402 16V4Z-D	PEG MTX GRX P7			
PEG MTX GRX C N7	C1576 ₁	2	0.1U 0402 16V4Z-D	PEG MTX GRX N7			
PEG MTX GRX C P8	C1577 ₁	2	0.1U 0402 16V4Z-D	PEG MTX GRX P8			
PEG MTX GRX C N8	C1578 ₁	2	0.1U 0402 16V4Z-D	PEG MTX GRX N8			
PEG MTX GRX C P9	C1579 ₁	2	0.1U 0402 16V4Z-D	PEG MTX GRX P9			
PEG MTX GRX C N9	C1580 ₁	2	0.1U 0402 16V4Z-D	PEG MTX GRX N9			
PEG MTX GRX C P10	C1581 ₁	2	0.1U 0402 16V4Z-D	PEG MTX GRX P10			
PEG MTX GRX C N10	C1582 ₁	2	0.1U 0402 16V4Z-D	PEG MTX GRX N10			
PEG MTX GRX C P11	C1583 ₁	2	0.1U 0402 16V4Z-D	PEG MTX GRX P11			
PEG MTX GRX C N11	C1584 ₁	2	0.1U 0402 16V4Z-D	PEG MTX GRX N11			
PEG MTX GRX C P12	C1585 ₁	2	0.1U 0402 16V4Z-D	PEG MTX GRX P12			
PEG MTX GRX C N12	C1586 ₁	2	0.1U 0402 16V4Z-D	PEG MTX GRX N12			
PEG MTX GRX C P13	C1587 ₁	2	0.1U 0402 16V4Z-D	PEG MTX GRX P13			
PEG MTX GRX C N13	C1588 ₁	2	0.1U 0402 16V4Z-D	PEG MTX GRX N13			
PEG MTX GRX C P14	C1589 ₁	2	0.1U 0402 16V4Z-D	PEG MTX GRX P14			
PEG MTX GRX C N14	C1590 ₁	2	0.1U 0402 16V4Z-D	PEG MTX GRX N14			
PEG MTX GRX C P15	C1591 ₁	2	0.1U 0402 16V4Z-D	PEG MTX GRX P15			
PEG MTX GRX C N15	C1592 ₁	2	0.1U 0402 16V4Z-D	PEG MTX GRX N15			

PROPRIETARY NOTE: THIS SHEET OF ENGINEERING DRAWING AND SPECIFICATIONS CONTAINS CONFIDENTIAL TRADE SECRET AND OTHER PROPRIETARY INFORMATION OF DELL INC. ("DELL"). THIS DOCUMENT MAY NOT BE TRANSMITTED OR COPIED WITHOUT THE EXPRESS WRITTEN AUTHORIZATION OF DELL. IN ADDITION, NEITHER THIS SHEET NOR THE INFORMATION IT CONTAINS MAY BE USED BY OR DISCLOSED TO ANY THIRD PARTY WITHOUT DELL'S EXPRESS WRITTEN CONSENT.



DELL CONFIDENTIAL/PROPRIETARY

Compal Electronics, Inc.			
Calistoga(3 of 6)			
File	Document Number	Rev 1.0	
LA-2792		Date:	Thursday, February 09, 2006
Sheet	12	of	70

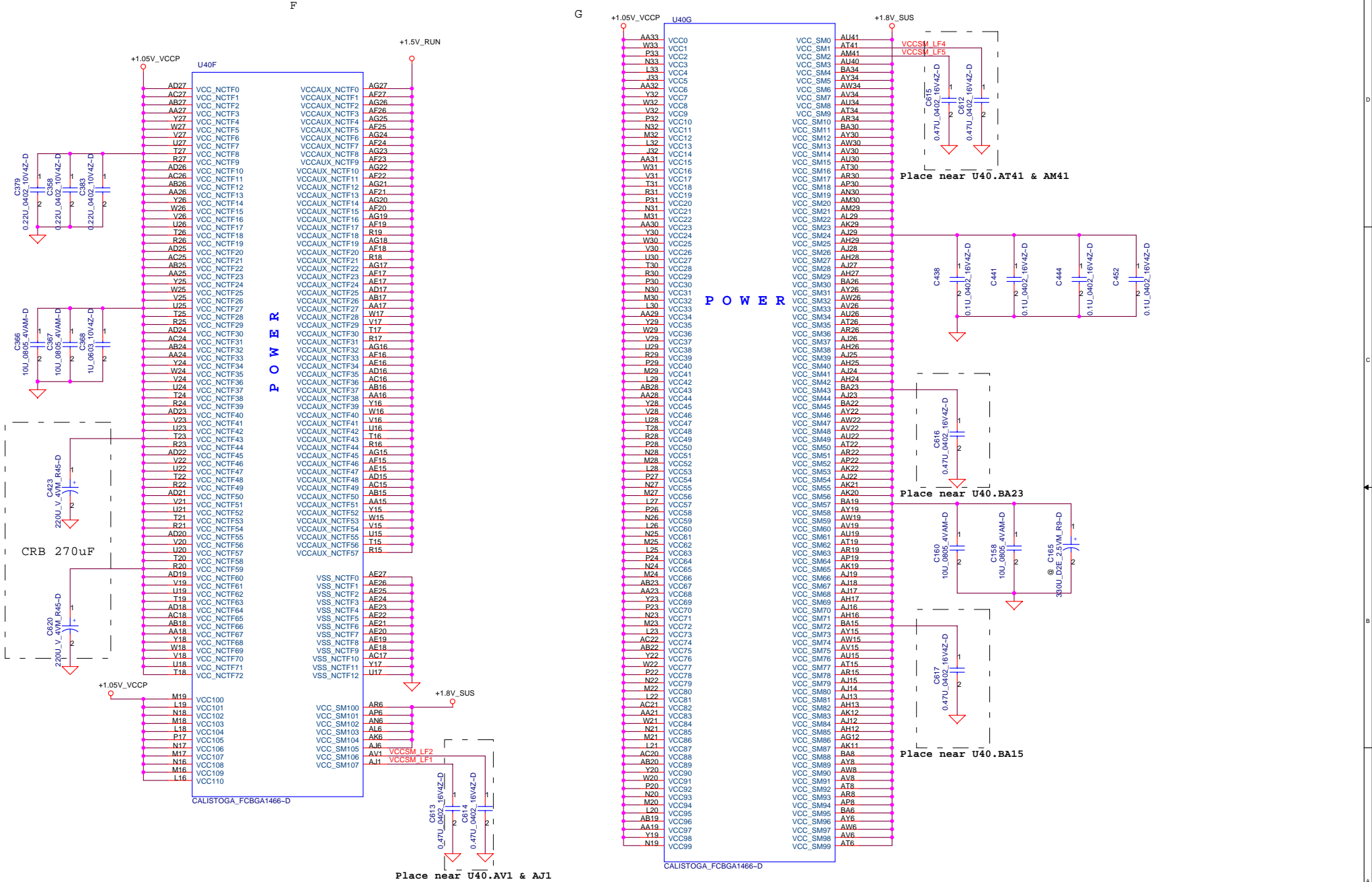

DELL CONFIDENTIAL/PROPRIETARY

Compal Electronics, Inc.

Calistoga (5 of 6)

LA-2792

Date: Thursday, February 09, 2006 Sheet 14 of 70

PROPRIETARY NOTE: THIS SHEET OF ENGINEERING DRAWING AND SPECIFICATIONS CONTAINS CONFIDENTIAL TRADE SECRET AND OTHER PROPRIETARY INFORMATION OF DELL INC. ("DELL"). THIS DOCUMENT MAY NOT BE TRANSMITTED OR COPIED WITHOUT THE EXPRESS WRITTEN AUTHORIZATION OF DELL. IN ADDITION, NEITHER THIS SHEET NOR THE INFORMATION IT CONTAINS MAY BE USED BY OR DISCLOSED TO ANY THIRD PARTY WITHOUT DELL'S EXPRESS WRITTEN CONSENT.



Rev 1.0

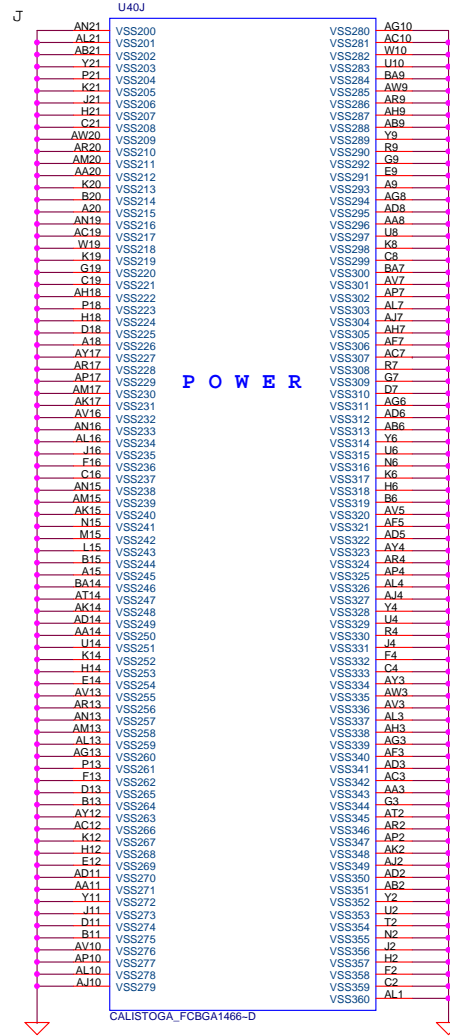
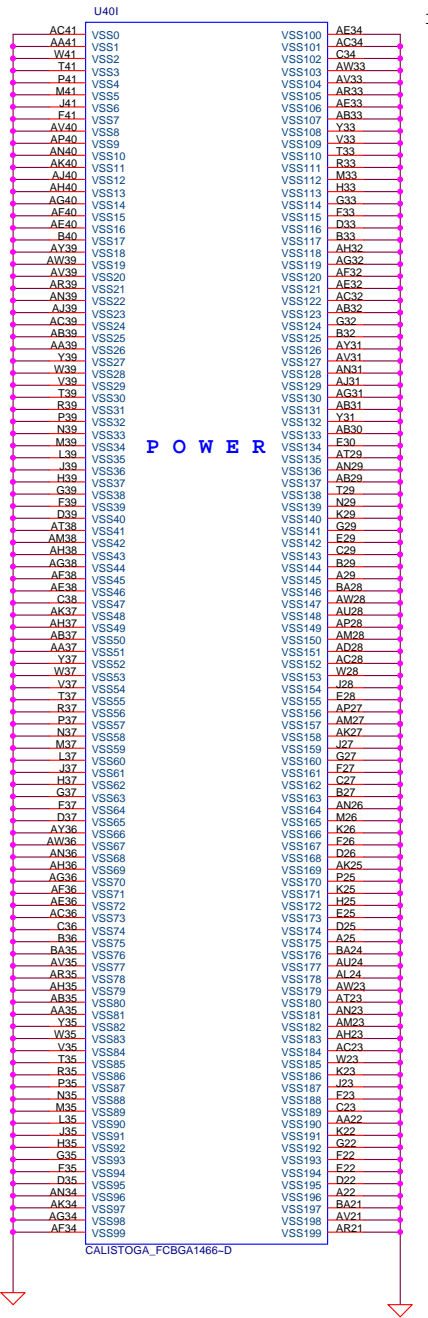

DELL CONFIDENTIAL/PROPRIETARY

Compal Electronics, Inc.

Calistoga (6 of 6)

LA-2792

Date: Thursday, February 09, 2006 Sheet 15 of 70

PROPRIETARY NOTE: THIS SHEET OF ENGINEERING DRAWING AND SPECIFICATIONS CONTAINS CONFIDENTIAL TRADE SECRET AND OTHER PROPRIETARY INFORMATION OF DELL INC. ("DELL"). THIS DOCUMENT MAY NOT BE TRANSMITTED OR COPIED WITHOUT THE EXPRESS WRITTEN AUTHORIZATION OF DELL. IN ADDITION, NEITHER THIS SHEET NOR THE INFORMATION IT CONTAINS MAY BE USED BY OR DISCLOSED TO ANY THIRD PARTY WITHOUT DELL'S EXPRESS WRITTEN CONSENT.



ON TOP SIDE

- 11 DDR_A_DQS#0[0..7] <<>>
- 11 DDR_A_D[0..63] <<>>
- 11 DDR_A_DM[0..7] <<>>
- 11 DDR_A_DQS#0[0..7K] <<>>
- 11 DDR_A_MA[0..13] <<>>

Layout Note:
Place near JDIM1

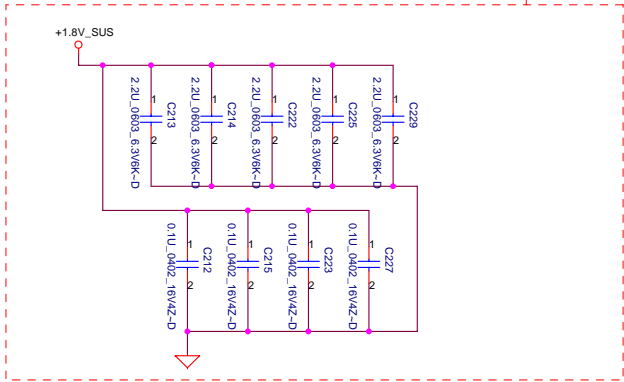

Layout Note:
Place one cap close to every 2 pullup resistors terminated to +0.9V_DDR_VTT

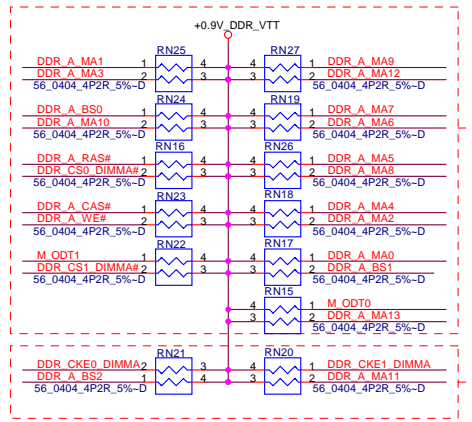
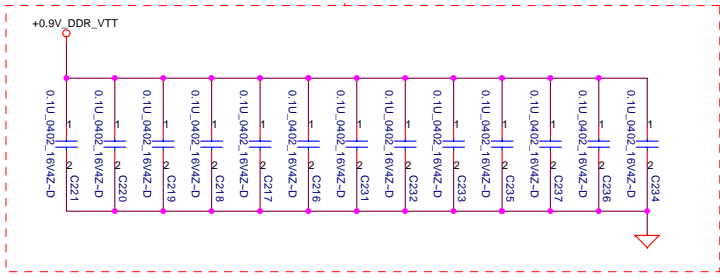

Layout Note:
Place these resistor closely DIMM0, all trace length < 750 mil

Layout Note:
Place these resistor closely DIMM0, all trace length Max=1.3"

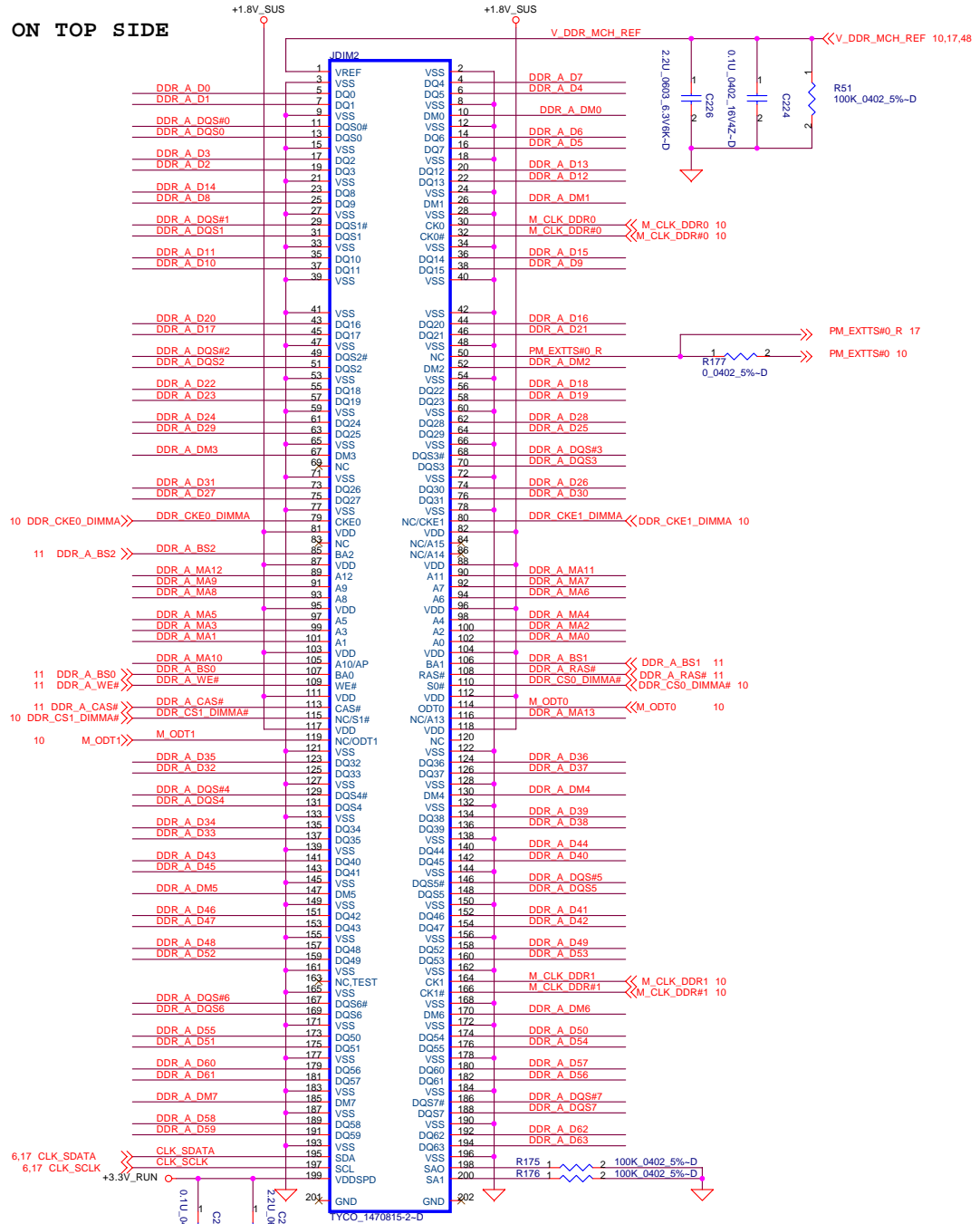

DIMMA RESERVE

PROPRIETARY NOTE: THIS SHEET OF ENGINEERING DRAWING AND SPECIFICATIONS CONTAINS CONFIDENTIAL TRADE SECRET AND OTHER PROPRIETARY INFORMATION OF DELL INC. ("DELL"). THIS DOCUMENT MAY NOT BE TRANSFERRED OR COPIED WITHOUT THE EXPRESS WRITTEN AUTHORIZATION OF DELL. IN ADDITION, NEITHER THIS SHEET NOR THE INFORMATION IT CONTAINS MAY BE USED BY OR DISCLOSED TO ANY THIRD PARTY WITHOUT DELL'S EXPRESS WRITTEN CONSENT.



DELL CONFIDENTIAL/PROPRIETARY

Compal Electronics, Inc.
DDR11-SODIMM SLOT1
LA-2792
 Date: Thursday, February 09, 2006 Sheet 16 of 70

- 11 DDR_B_DQS#[0..7] <<<>>>
- 11 DDR_B_DQ[0..63] <<<>>>
- 11 DDR_B_DM[0..7] <<<>>>
- 11 DDR_B_DQS[0..7] <<<>>>
- 11 DDR_B_MA[0..13] <<<>>>

Layout Note:
Place near JDIM2

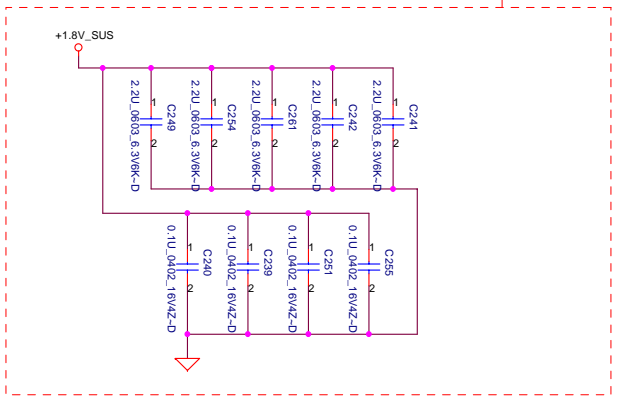

Layout Note:
Place one cap close to every 2 pullup resistors terminated to +0.9V_DDR_VTT

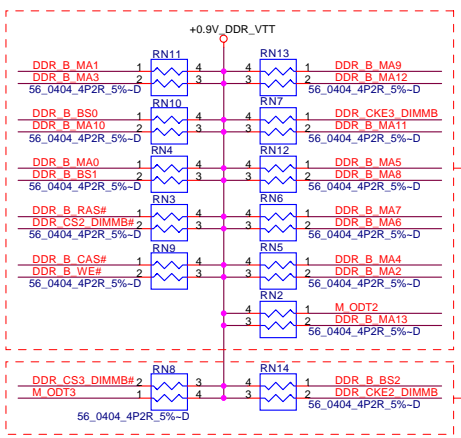
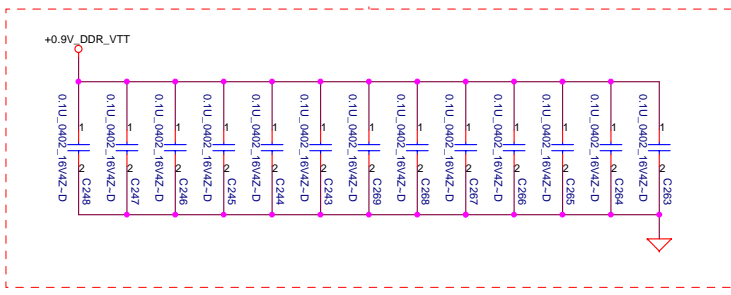

Layout Note:
Place these resistor closely DIMM0, all trace length < 750 mil

Layout Note:
Place these resistor closely DIMM0, all trace length Max=1.3"

ON BOTTOM SIDE

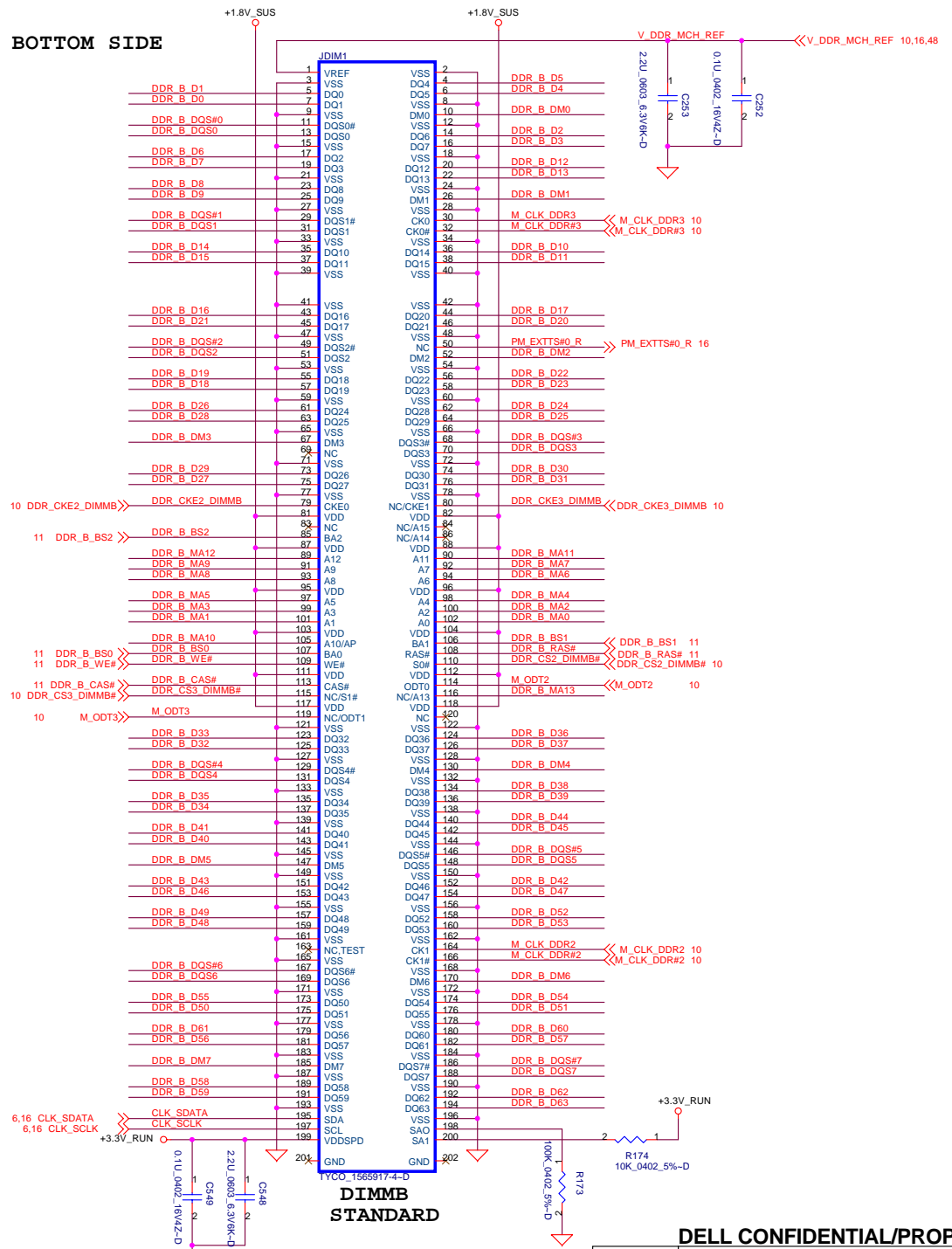

PROPRIETARY NOTE: THIS SHEET OF ENGINEERING DRAWING AND SPECIFICATIONS CONTAINS CONFIDENTIAL TRADE SECRET AND OTHER PROPRIETARY INFORMATION OF DELL INC. ("DELL"). THIS DOCUMENT MAY NOT BE TRANSMITTED, COPIED, REPRODUCED, OR OTHERWISE DISCLOSED WITHOUT THE EXPRESS WRITTEN AUTHORIZATION OF DELL. IN ADDITION, NEITHER THIS SHEET NOR THE INFORMATION IT CONTAINS MAY BE USED BY OR DISCLOSED TO ANY THIRD PARTY WITHOUT DELL'S EXPRESS WRITTEN CONSENT.



DELL CONFIDENTIAL/PROPRIETARY

Compal Electronics, Inc.		
DDRII-SODIMM SLOT2		
File	Document Number	Rev
	LA-2792	1.0
Date:	Thursday, February 09, 2006	Sheet 17 of 70

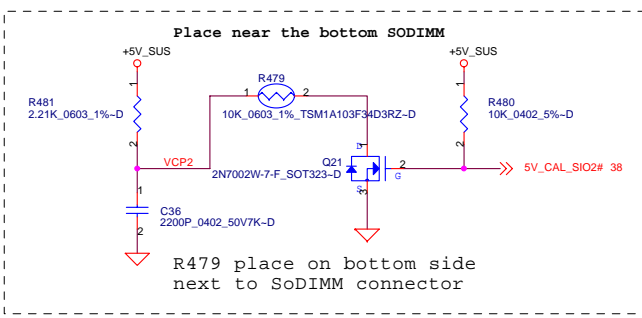
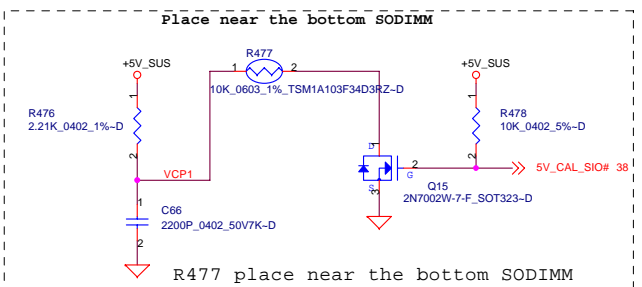
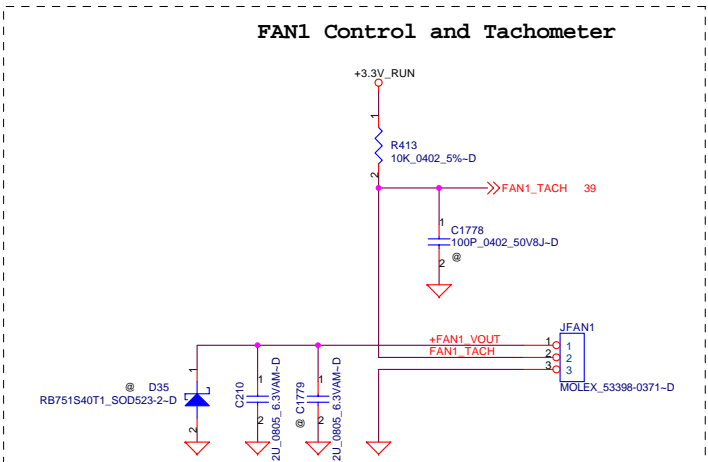

$$VSET = \frac{R262}{R249+R262} \times 3.3V$$

$$VSET = \left(\frac{Tp-70}{21} \right)$$

Place C341 close to the Guardian pins as possible

DP2, DN2 routing together. Trace width / Spacing = 10 / 10 mil

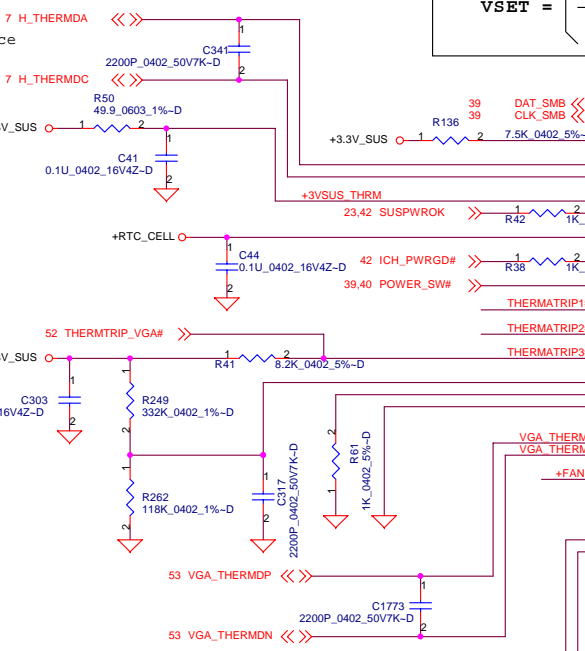

VGA_THERMDN, VGA_THERMDP routing together. Trace width / Spacing = 10 / 10 mil

Place C1773 close to the Guardian pins as possible

Place cap close to the Guardian pins as possible.

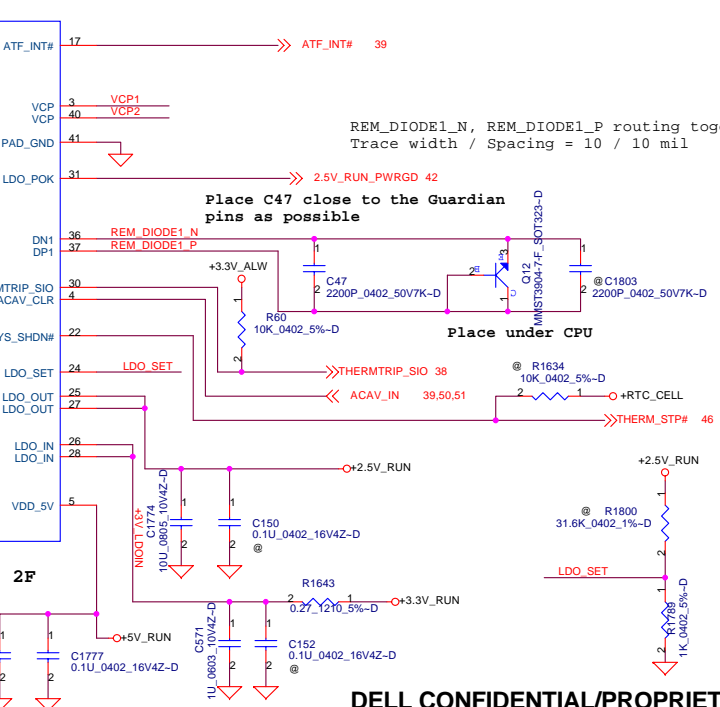

PROPRIETARY NOTE: THIS SHEET OF ENGINEERING DRAWING AND SPECIFICATIONS CONTAINS CONFIDENTIAL TRADE SECRET AND OTHER PROPRIETARY INFORMATION OF DELL INC. ("DELL"). THIS DOCUMENT MAY NOT BE TRANSMITTED OR COPIED WITHOUT THE EXPRESS WRITTEN AUTHORIZATION OF DELL. IN ADDITION, NEITHER THIS SHEET NOR THE INFORMATION IT CONTAINS MAY BE USED BY OR DISCLOSED TO ANY THIRD PARTY WITHOUT DELL'S EXPRESS WRITTEN CONSENT.



DELL CONFIDENTIAL/PROPRIETARY

Compal Electronics, Inc.		
Title		
FAN & Thermal Sensor		
Size	Document Number	Rev
	LA-2792	1.0
Date:	Thursday, February 09, 2006	Sheet 18 of 70

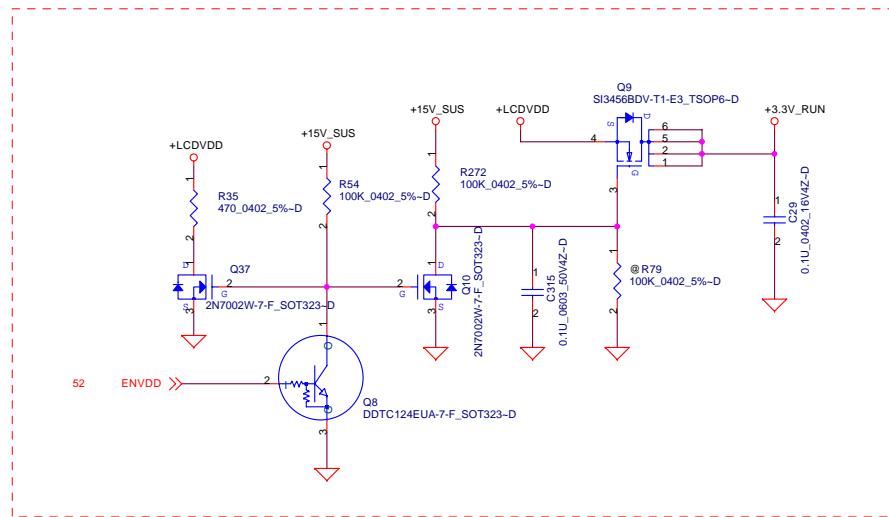
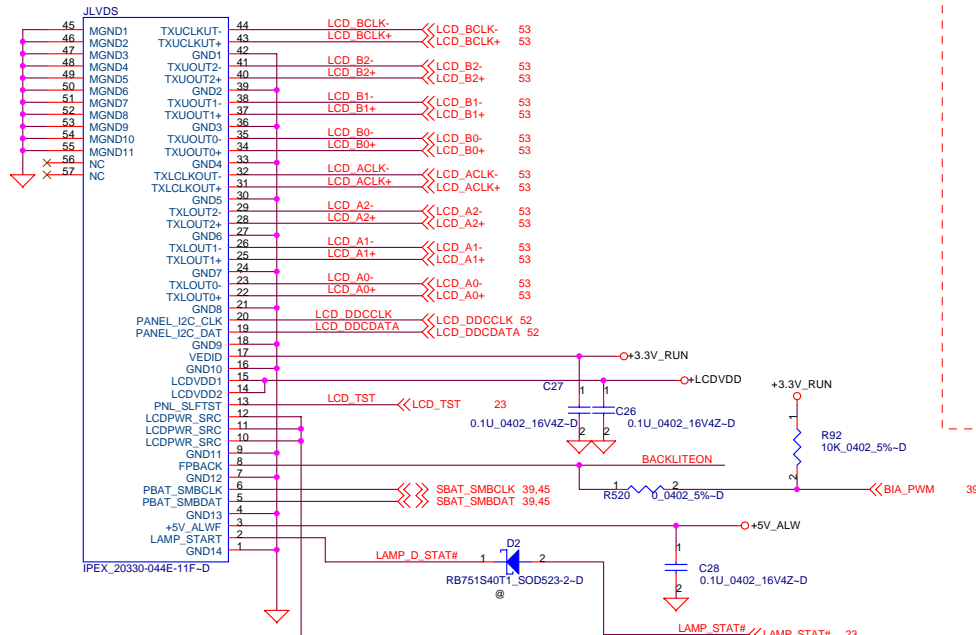

BACKLITEON for D'05;
BIA_PWM for M'07

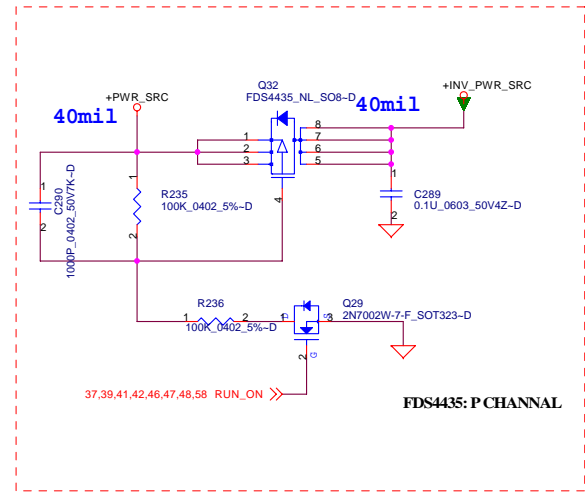

FDS4435: P CHANNEL

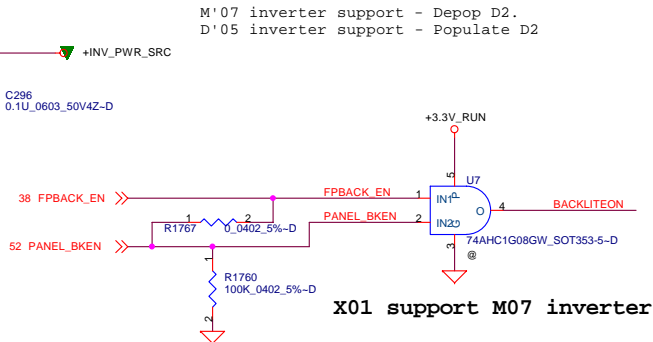

X01 support M07 inverter

M'07 inverter support - Depop D2.
D'05 inverter support - Populate D2

M'07 inverter support - Populate R520,R1767 Depop U7.
D'05 inverter support - Populate U7, Depop R520,R1767

PROPRIETARY NOTE: THIS SHEET OF ENGINEERING DRAWINGS AND SPECIFICATIONS CONTAINS CONFIDENTIAL TRADE SECRET AND OTHER PROPRIETARY INFORMATION OF DELL, INC. ("DELL"). THIS DOCUMENT MAY NOT BE TRANSFERRED OR COPIED WITHOUT THE EXPRESS WRITTEN AUTHORIZATION OF DELL. IN ADDITION, NEITHER THIS SHEET NOR THE INFORMATION IT CONTAINS MAY BE USED BY OR DISCLOSED TO ANY THIRD PARTY WITHOUT DELL'S EXPRESS WRITTEN CONSENT.



DELL CONFIDENTIAL/PROPRIETARY

Compal Electronics, Inc.

Title		
Internal LVDS		
Size	Document Number	Rev
	LA-2792	1.0
Date:	Thursday, February 08, 2006	Sheet 19 of 70

36.52 VGA_RED >> VGA_RED
 36.52 VGA_GRN >> VGA_GRN
 36.52 VGA_BLU >> VGA_BLU

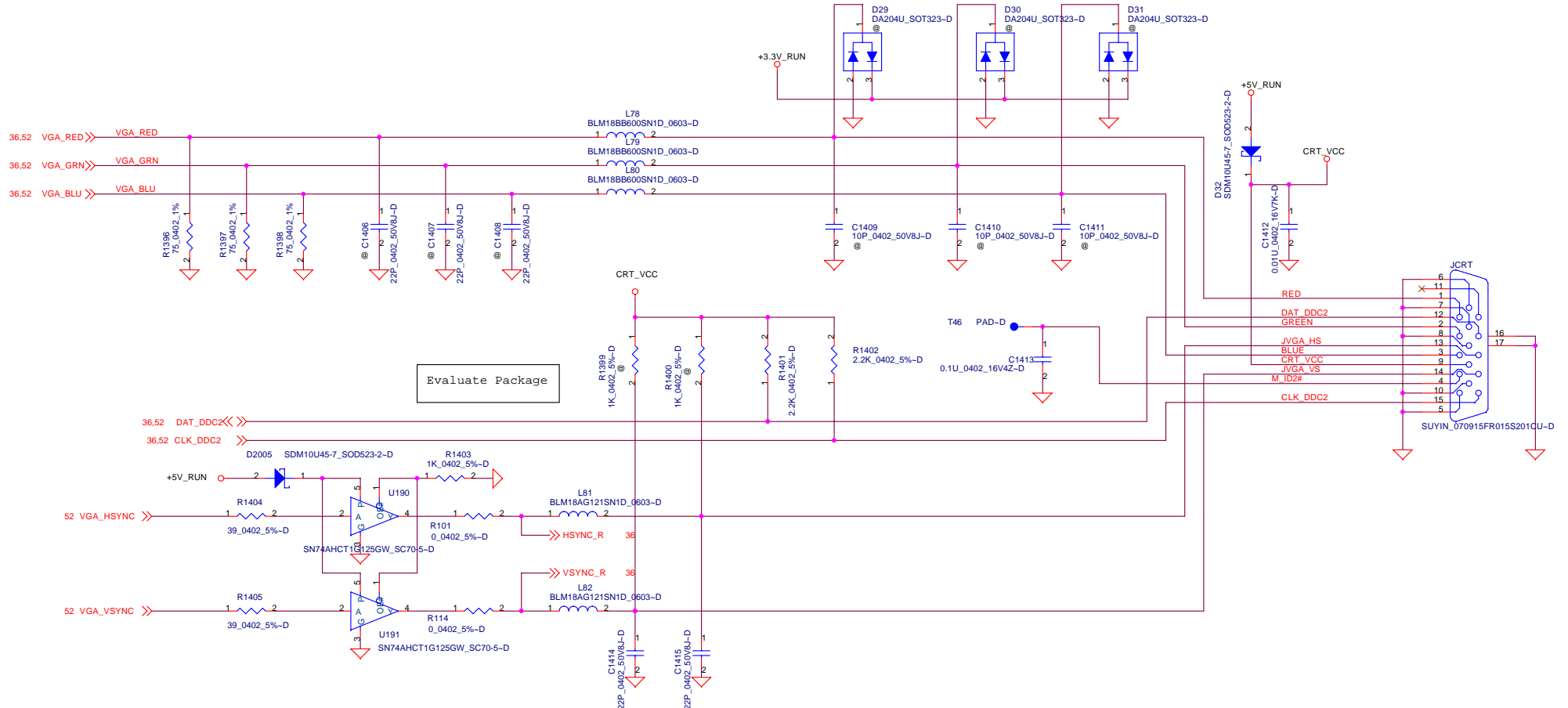

Evaluate Package

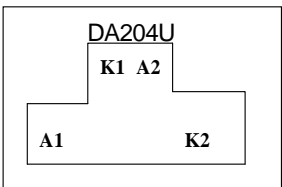

PROPRIETARY NOTE: THIS SHEET OF ENGINEERING DRAWING AND SPECIFICATIONS CONTAINS CONFIDENTIAL TRADE SECRET AND OTHER PROPRIETARY INFORMATION OF DELL INC. ("DELL"). THIS DOCUMENT MAY NOT BE TRANSFERRED OR COPIED WITHOUT THE EXPRESS WRITTEN AUTHORIZATION OF DELL. IN ADDITION, NEITHER THIS SHEET NOR THE INFORMATION IT CONTAINS MAY BE USED BY OR DISCLOSED TO ANY THIRD PARTY WITHOUT DELL'S EXPRESS WRITTEN CONSENT.



DELL CONFIDENTIAL/PROPRIETARY

Compal Electronics, Inc.

Title		CRT	
Size	Document Number	Rev	
	LA-2792	1.0	
Date:	Thursday, February 09, 2006	Sheet	20 of 70

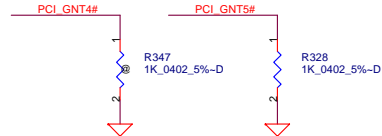
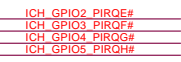
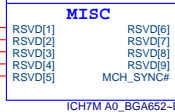
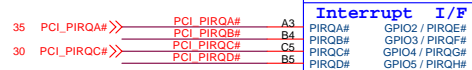
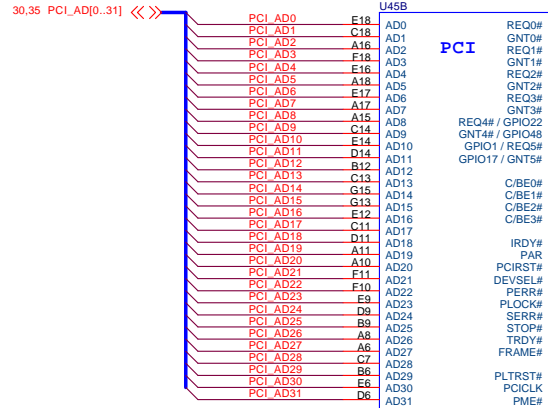
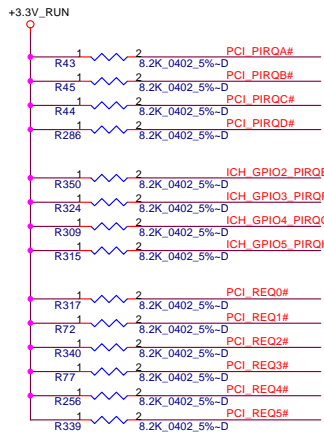
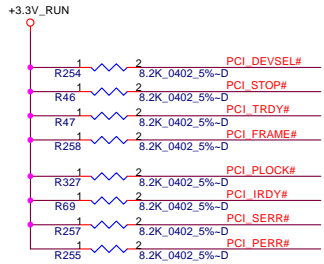

	GNT5# R328	GNT4# R347
LPC (11)	unstuff	unstuff
PCI (10)	unstuff	stuff
SPI (01)	stuff	unstuff

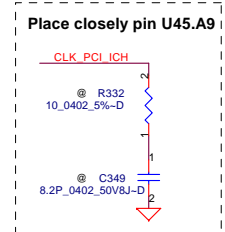
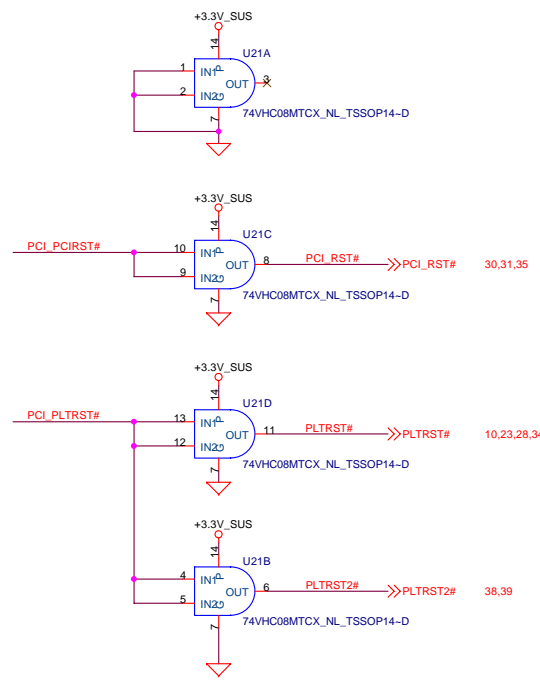

DELL CONFIDENTIAL/PROPRIETARY

Compal Electronics, Inc.

Title: ICH7(1/4)

Size: Document Number

LA-2792

Date: Thursday, February 09, 2006 Sheet 21 of 70

Rev: 1.0

PROPRIETARY NOTE: THIS SHEET OF ENGINEERING DRAWING AND SPECIFICATIONS CONTAINS CONFIDENTIAL TRADE SECRET AND OTHER PROPRIETARY INFORMATION OF DELL INC. ("DELL"). THIS DOCUMENT MAY NOT BE TRANSFERRED OR COPIED WITHOUT THE EXPRESS WRITTEN AUTHORIZATION OF DELL. IN ADDITION, NEITHER THIS SHEET NOR THE INFORMATION IT CONTAINS MAY BE USED BY OR DISCLOSED TO ANY THIRD PARTY WITHOUT DELL'S EXPRESS WRITTEN CONSENT.

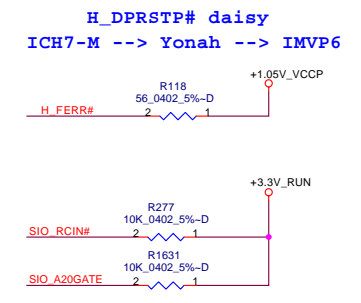
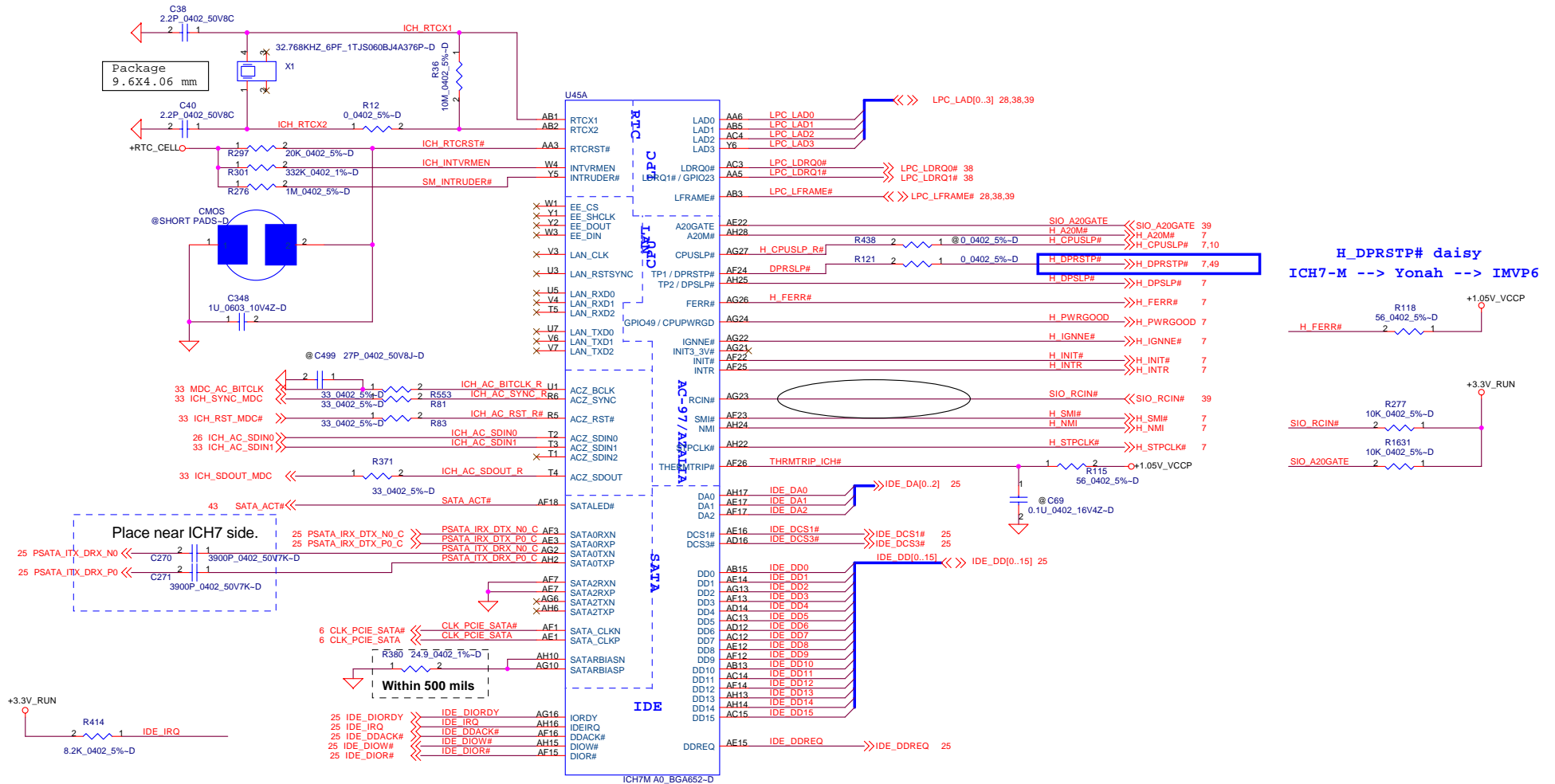

Place near ICH7 side.

Within 500 mils

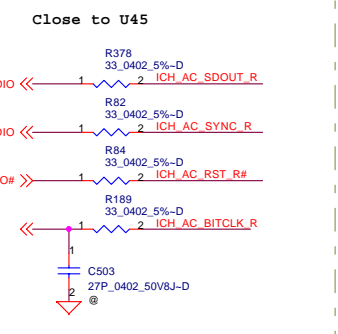

PROPRIETARY NOTE: THIS SHEET OF ENGINEERING DRAWING AND SPECIFICATIONS CONTAINS CONFIDENTIAL TRADE SECRET AND OTHER PROPRIETARY INFORMATION OF DELL INC. ("DELL"). THIS DOCUMENT MAY NOT BE TRANSMITTED OR COPIED WITHOUT THE EXPRESS WRITTEN AUTHORIZATION OF DELL. IN ADDITION, NEITHER THIS SHEET NOR THE INFORMATION IT CONTAINS MAY BE USED BY OR DISCLOSED TO ANY THIRD PARTY WITHOUT DELL'S EXPRESS WRITTEN CONSENT.



DELL CONFIDENTIAL/PROPRIETARY

Compal Electronics, Inc.

Title ICH7(2/4)		
Size	Document Number LA-2792	Rev 1.0
Date	Thursday, February 09, 2006	Sheet 22 of 70

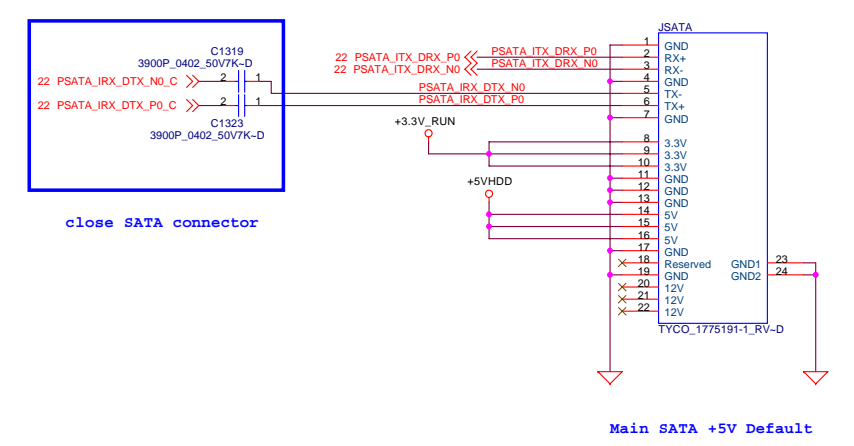
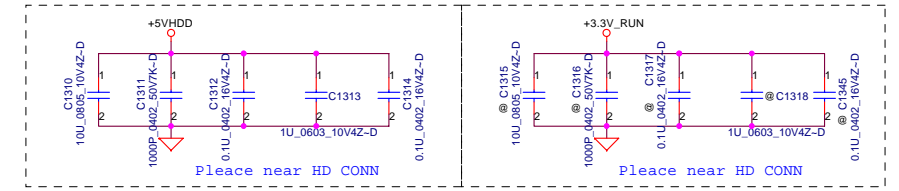
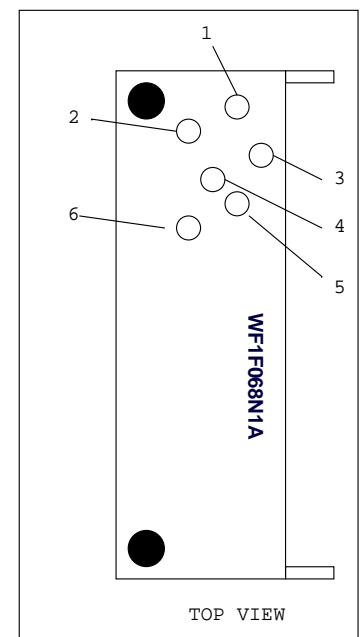
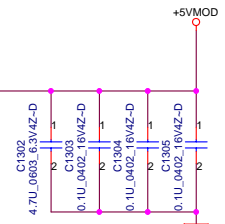
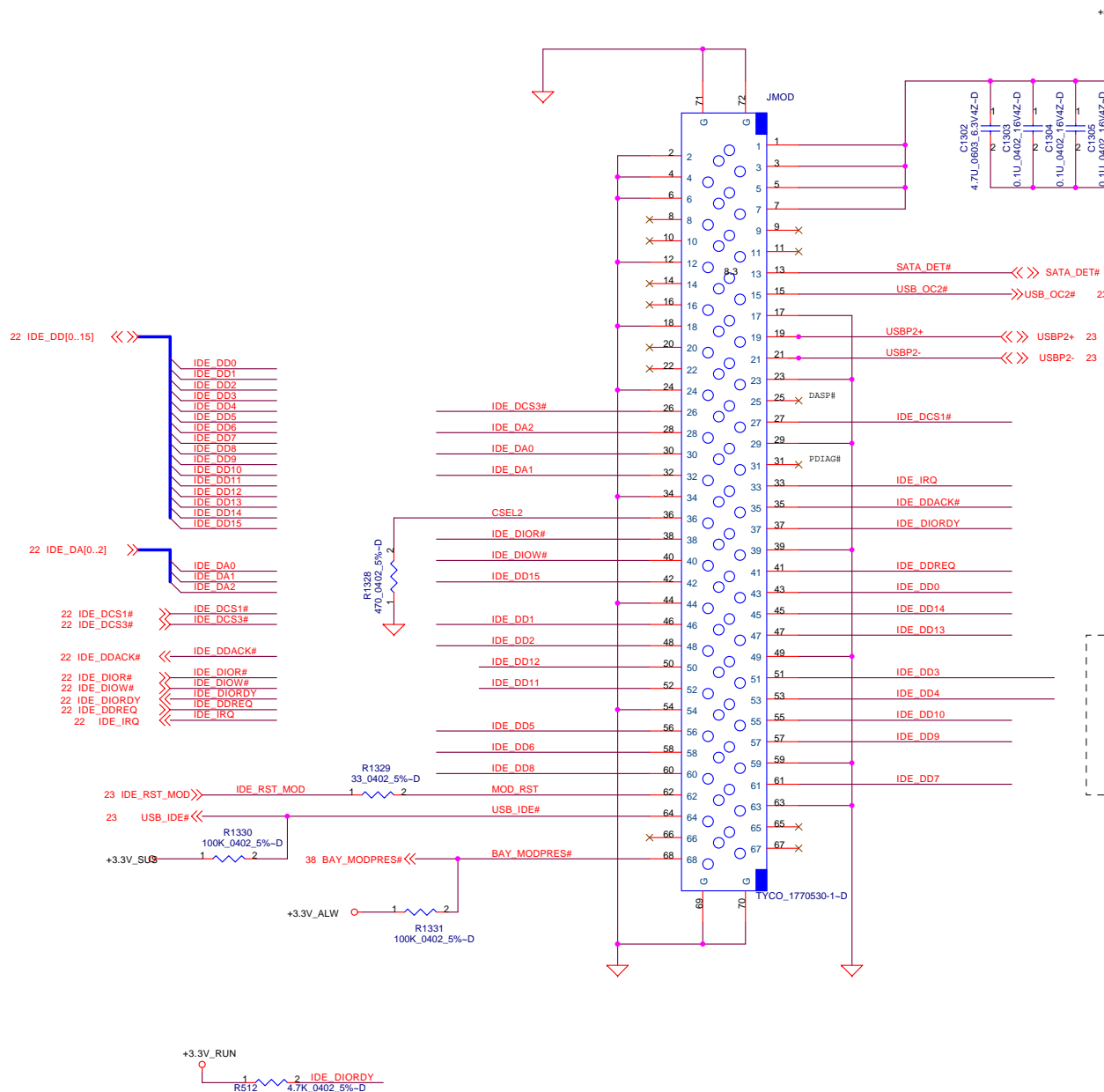

PROPRIETARY NOTE: THIS SHEET OF ENGINEERING DRAWING AND SPECIFICATIONS CONTAINS CONFIDENTIAL TRADE SECRET AND OTHER PROPRIETARY INFORMATION OF DELL INC. ("DELL") THIS DOCUMENT MAY NOT BE TRANSFERRED OR COPIED WITHOUT THE EXPRESS WRITTEN AUTHORIZATION OF DELL. IN ADDITION, NEITHER THIS SHEET NOR THE INFORMATION IT CONTAINS MAY BE USED BY OR DISCLOSED TO ANY THIRD PARTY WITHOUT DELL'S EXPRESS WRITTEN CONSENT.

DELL CONFIDENTIAL/PROPRIETARY

Title: **DVD MODULE**

Size: Document Number **LA-2792** Rev 1.0

Date: Thursday, February 09, 2006 Sheet 25 of 70

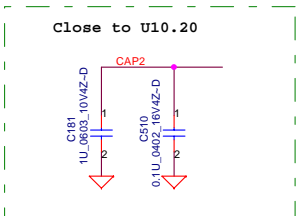
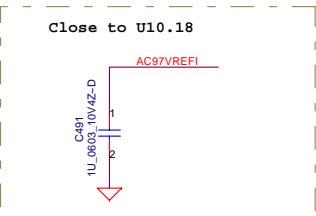
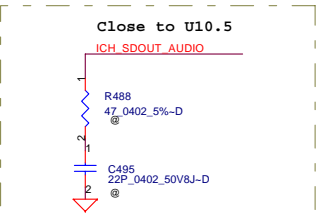
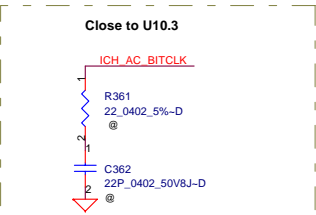
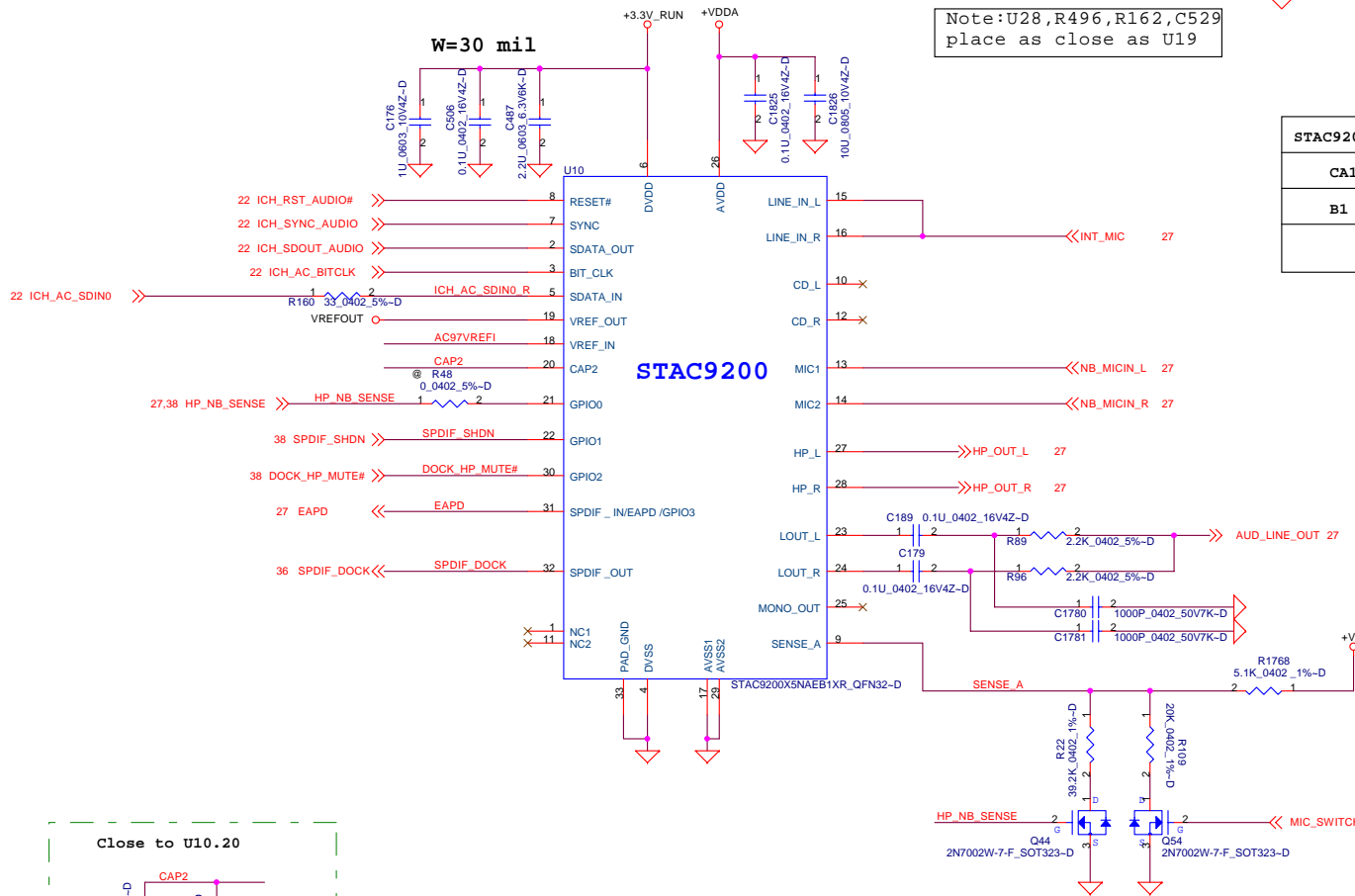
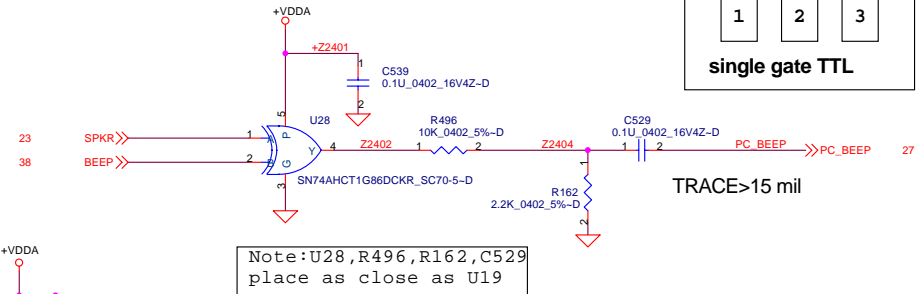
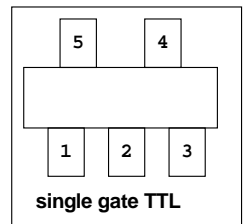
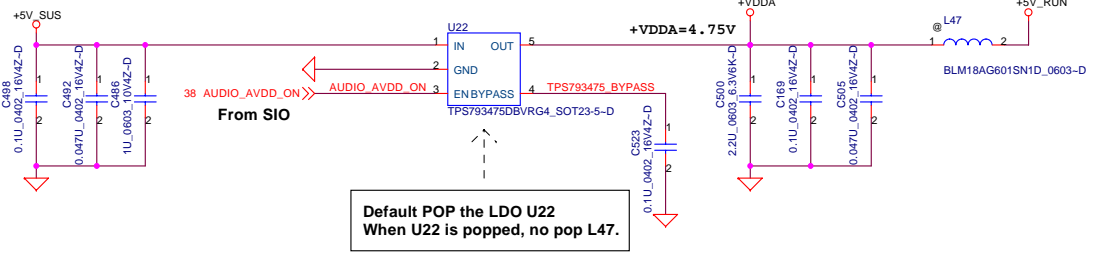

STAC9200 Rev.	R22	R109
CA1	5.11K	10K
B1	39.2K	20K

PROPRIETARY NOTE: THIS SHEET OF ENGINEERING DRAWING AND SPECIFICATIONS CONTAINS CONFIDENTIAL TRADE SECRET AND OTHER PROPRIETARY INFORMATION OF DELL INC. ("DELL"). THIS DOCUMENT MAY NOT BE TRANSMITTED OR COPIED WITHOUT THE EXPRESS WRITTEN AUTHORIZATION OF DELL. IN ADDITION, NEITHER THIS SHEET NOR THE INFORMATION IT CONTAINS MAY BE USED BY OR DISCLOSED TO ANY THIRD PARTY WITHOUT DELL'S EXPRESS WRITTEN CONSENT.



DELL CONFIDENTIAL/PROPRIETARY

Compal Electronics, Inc.

Azalia (HD) Codec

LA-2792

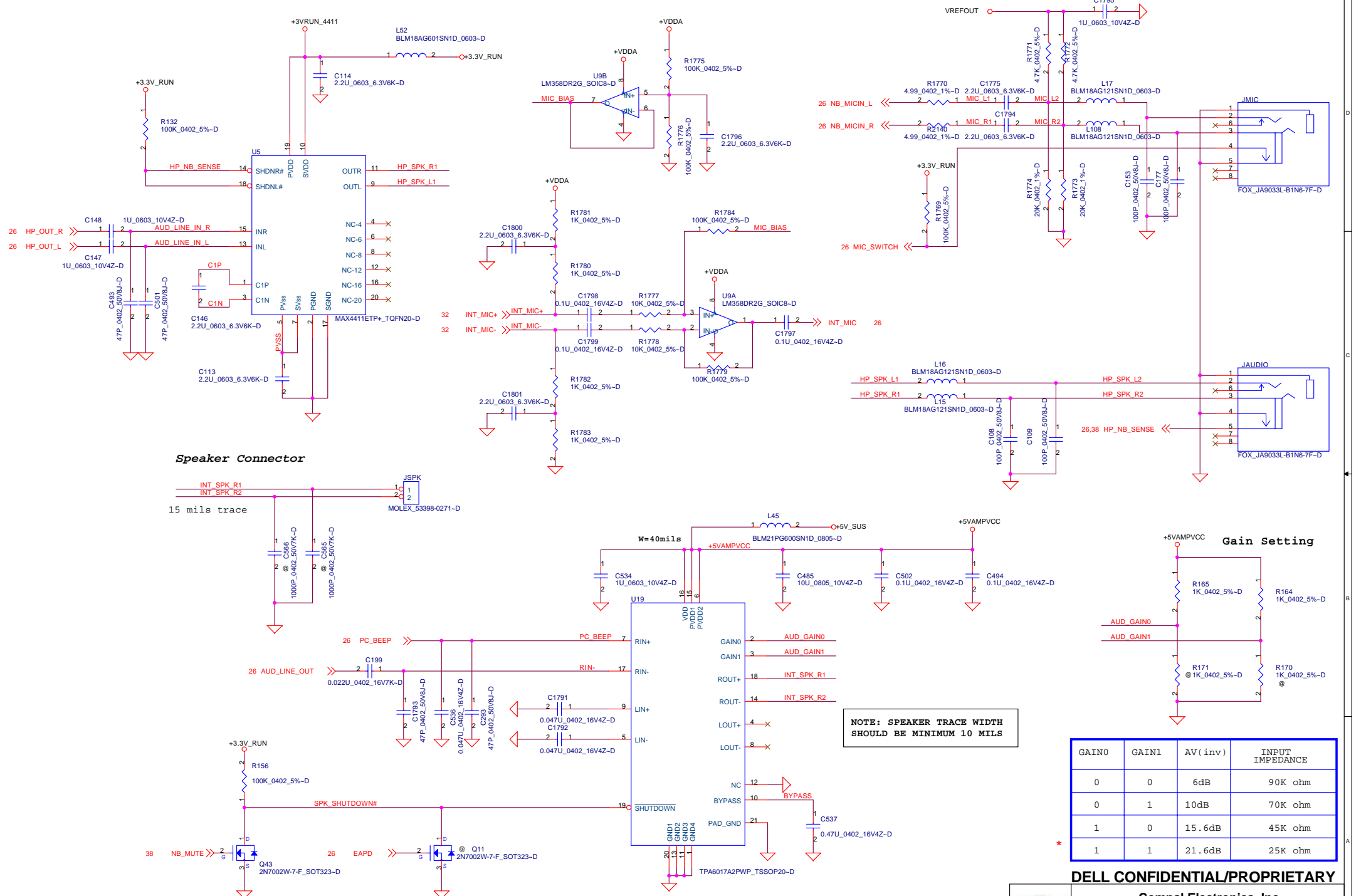

Speaker Connector

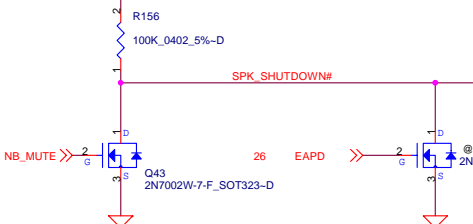
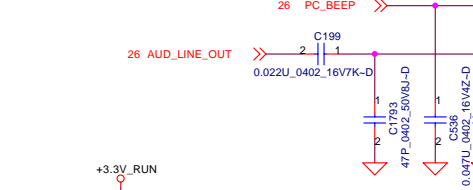
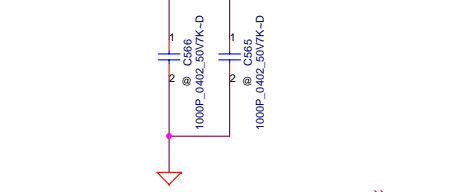
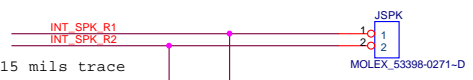

NOTE: SPEAKER TRACE WIDTH SHOULD BE MINIMUM 10 MILS

Gain Setting

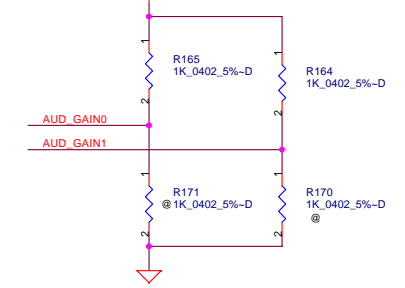

GAIN0	GAIN1	AV (inv)	INPUT IMPEDANCE
0	0	6dB	90K ohm
0	1	10dB	70K ohm
1	0	15.6dB	45K ohm
1	1	21.6dB	25K ohm

PROPRIETARY NOTE: THIS SHEET OF ENGINEERING DRAWING AND SPECIFICATIONS CONTAINS CONFIDENTIAL TRADE SECRET AND OTHER PROPRIETARY INFORMATION OF DELL INC. ("DELL"). THIS DOCUMENT MAY NOT BE TRANSMITTED OR COPIED WITHOUT THE EXPRESS WRITTEN AUTHORIZATION OF DELL. IN ADDITION, NEITHER THIS SHEET NOR THE INFORMATION IT CONTAINS MAY BE USED BY OR DISCLOSED TO ANY THIRD PARTY WITHOUT DELL'S EXPRESS WRITTEN CONSENT.



DELL CONFIDENTIAL/PROPRIETARY

Compal Electronics, Inc.

AMP and PHONE JACK

LA-2792
Date: Thursday, February 09, 2006 Sheet 27 of 70 Rev 1.0

Layout Notice : Place as close chip as possible.

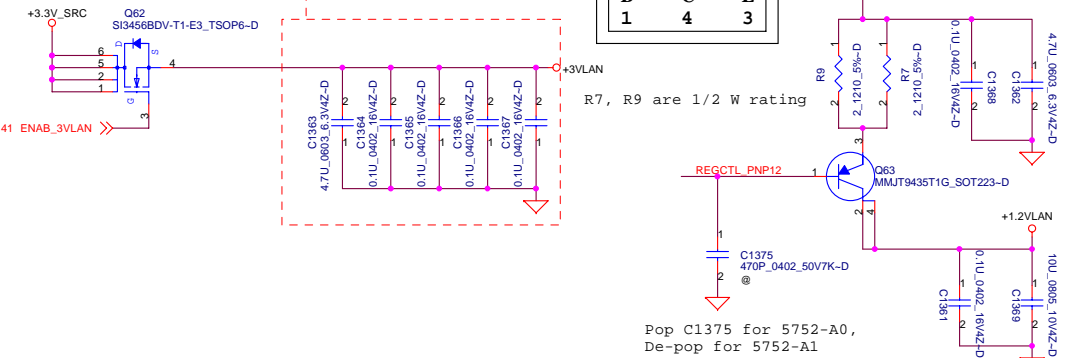
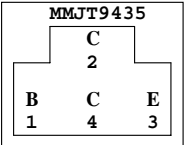

Layout Notice : 1.2V filter. Place as close chip as possible.

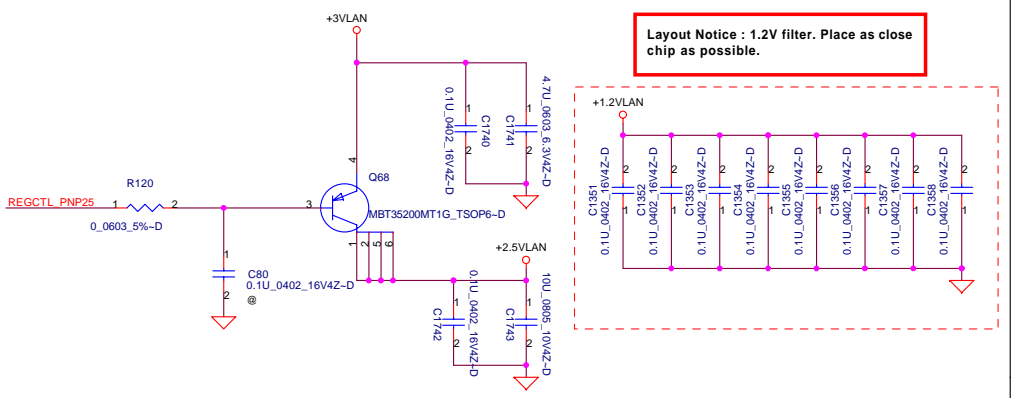

Pop C1375 for 5752-A0, De-pop for 5752-A1

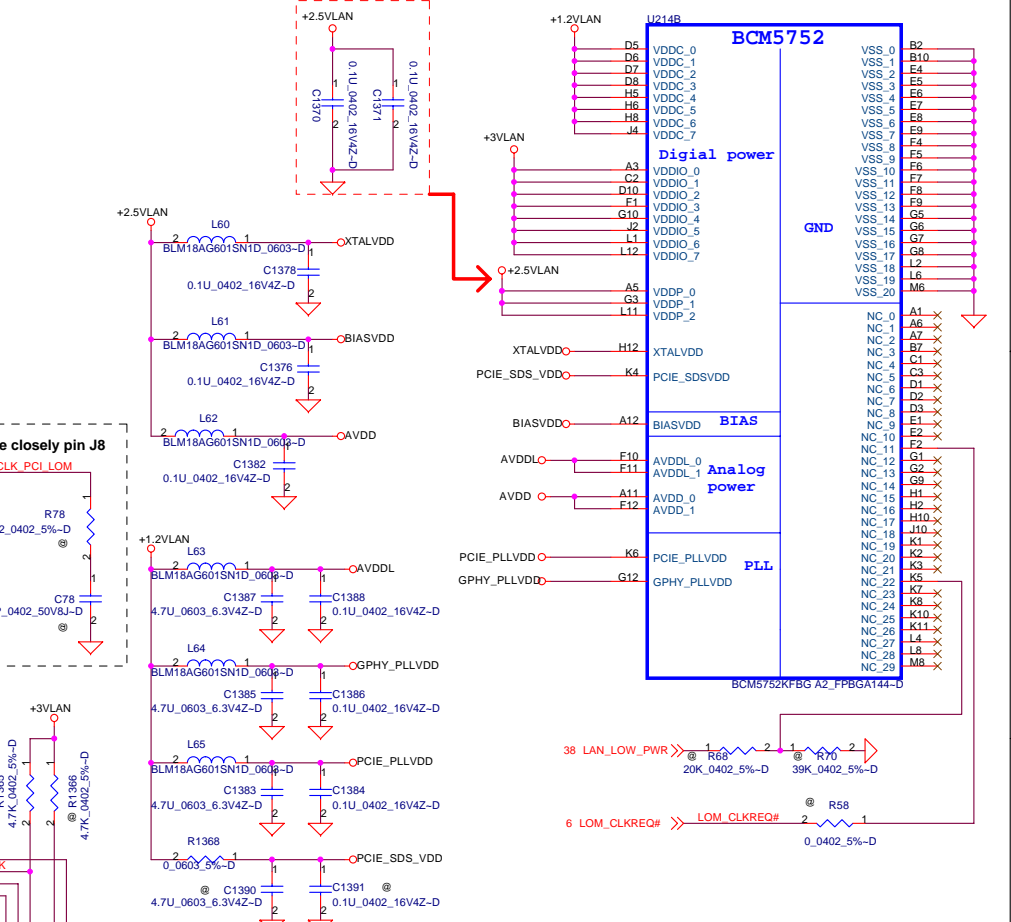
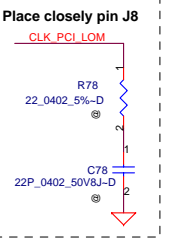
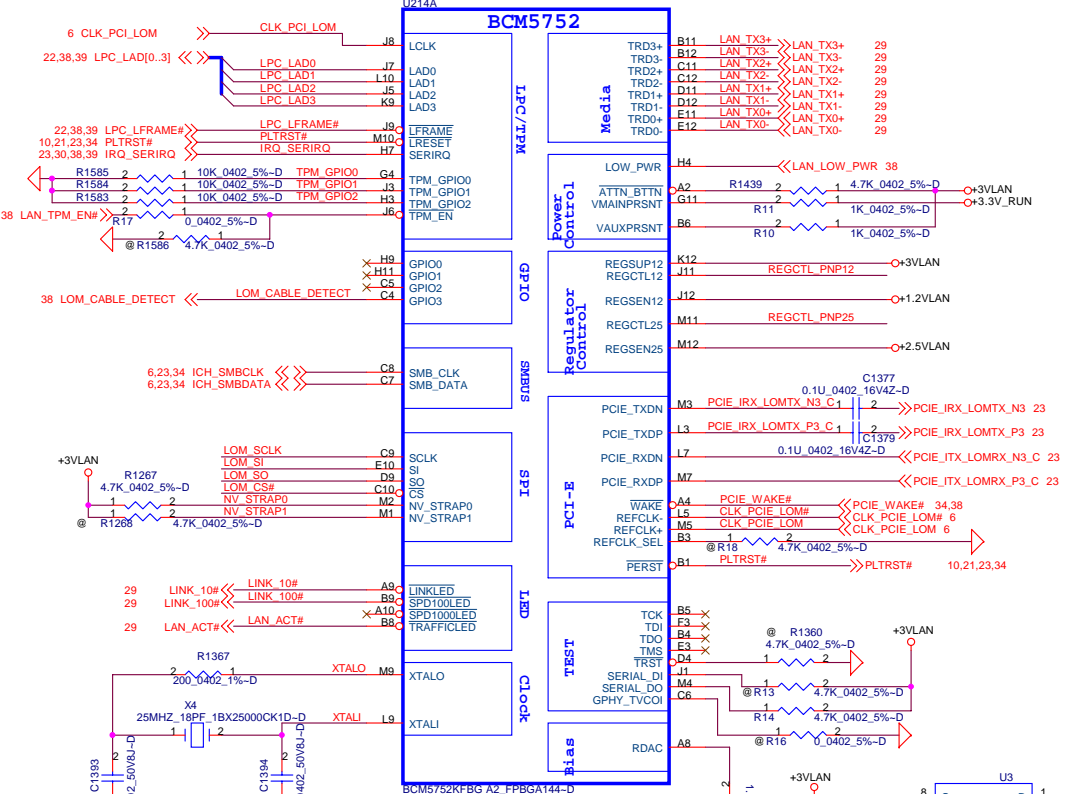

Layout Notice : No high speed signal should be routed near RDAC or on adjacent layer to RDAC

	NV_STRAP1	NV_STRAP0	SO	SI	CS#	SCLK
Atmel AT45BCM021B	0	0	1	0	1	1
ST M45PE20	0	1	1	0	0	1

PROPRIETARY NOTE: THIS SHEET OF ENGINEERING DRAWING AND SPECIFICATIONS CONTAINS CONFIDENTIAL TRADE SECRET AND OTHER PROPRIETARY INFORMATION OF DELL INC. ("DELL"). THIS DOCUMENT MAY NOT BE TRANSFERRED OR COPIED WITHOUT THE EXPRESS WRITTEN AUTHORIZATION OF DELL. IN ADDITION, NEITHER THIS SHEET NOR THE INFORMATION IT CONTAINS MAY BE USED BY OR DISCLOSED TO ANY THIRD PARTY WITHOUT DELL'S EXPRESS WRITTEN CONSENT.

DELL CONFIDENTIAL/PROPRIETARY

File: **BCM5751M**

Size: Document Number

LA-2792

Date: Thursday, February 09, 2006 Sheet 23 of 70

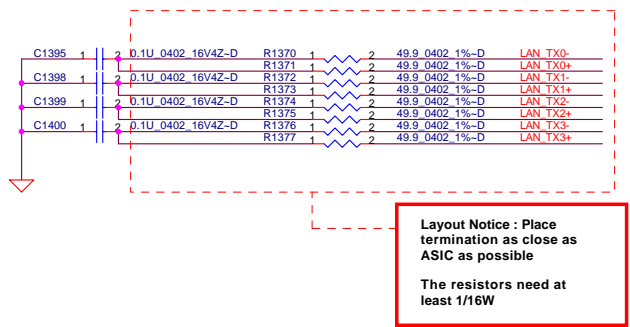

Layout Notice : Place termination as close as ASIC as possible

The resistors need at least 1/16W

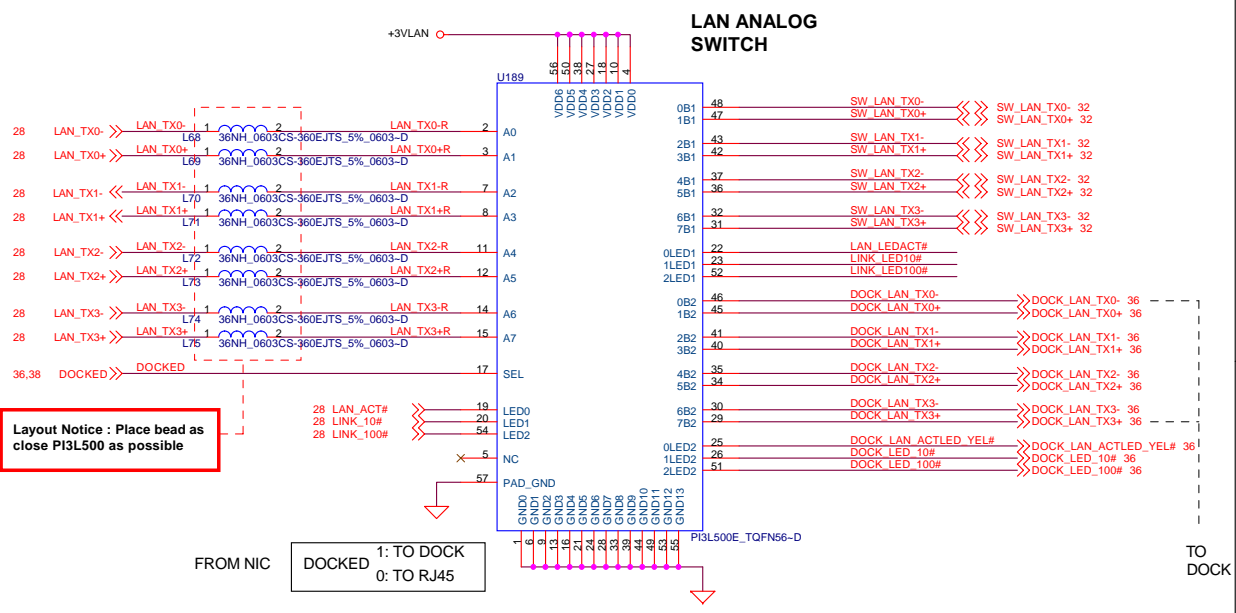

Layout Notice : Place bead as close PI3L500 as possible

**DOCKED 1: TO DOCK
0: TO RJ45**

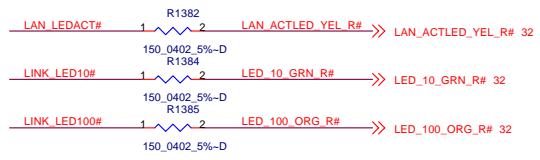
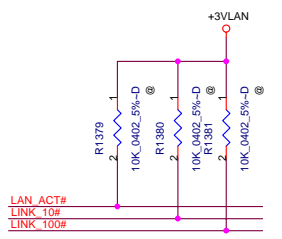

PROPRIETARY NOTE: THIS SHEET OF ENGINEERING DRAWING AND SPECIFICATIONS CONTAINS CONFIDENTIAL TRADE SECRET AND OTHER PROPRIETARY INFORMATION OF DELL INC. ("DELL"). THIS DOCUMENT MAY NOT BE TRANSFERRED OR COPIED WITHOUT THE EXPRESS WRITTEN AUTHORIZATION OF DELL. IN ADDITION, NEITHER THIS SHEET NOR THE INFORMATION IT CONTAINS MAY BE USED BY OR DISCLOSED TO ANY THIRD PARTY WITHOUT DELL'S EXPRESS WRITTEN CONSENT.

	DELL CONFIDENTIAL/PROPRIETARY		
	Title LAN TRANSFORMER		
	Size	Document Number LA-2792	Rev 1.0
Date: Thursday, February 09, 2006		Sheet 29 of 70	

NOTE:
THIS PAGE SHOWS THE OZ601B CONFIGURED WITH
EXTERNAL IDSEL AND WITHOUT 12V VPP SUPPORT.

IDSEL SELECT POWER-ON-STRAPPING
(SEE NOTE & TABLE FOR OPTIONS)

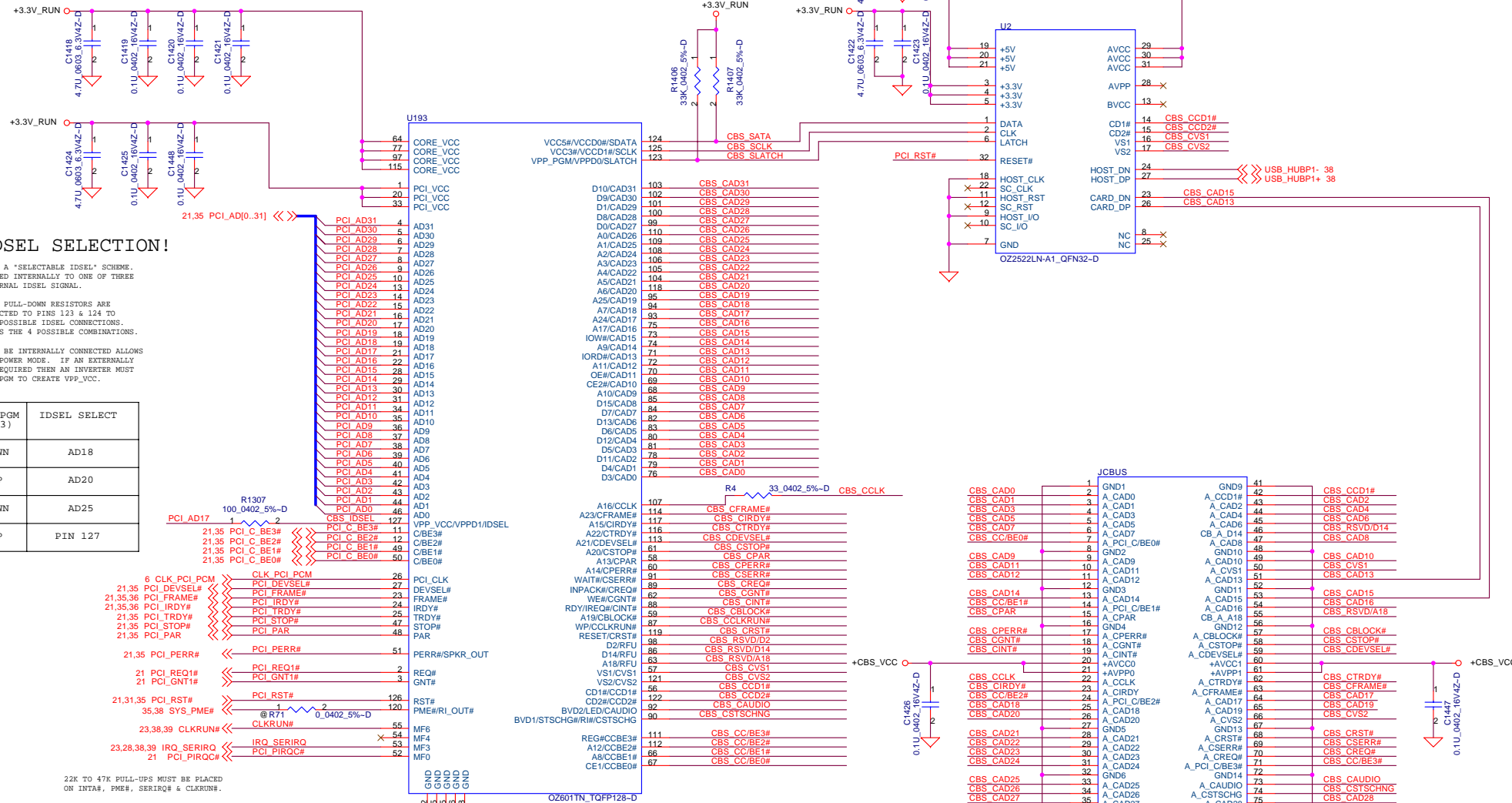

NOTE: IDSEL SELECTION!

THIS DEVICE UTILIZES A "SELECTABLE IDSEL" SCHEME. IDSEL CAN BE CONNECTED INTERNALLY TO ONE OF THREE PCI AD LINES OR EXTERNAL IDSEL SIGNAL.

22K TO 47K PULL-UP & PULL-DOWN RESISTORS ARE REQUIRED TO BE CONNECTED TO PINS 123 & 124 TO SELECT ONE OF THE 4 POSSIBLE IDSEL CONNECTIONS. THE TABLE BELOW SHOWS THE 4 POSSIBLE COMBINATIONS.

CONFIGURING IDSEL TO BE INTERNALLY CONNECTED ALLOWS FOR A FULL PARALLEL POWER MODE. IF AN EXTERNALLY CONNECTED IDSEL IS REQUIRED THEN AN INVERTER MUST BE CONNECTED TO VPP_PGM TO CREATE VPP_VCC.

VCC5# (124)	VPP_PGM (123)	IDSEL SELECT
DOWN	DOWN	AD18
DOWN	UP	AD20
UP	DOWN	AD25
UP	UP	PIN 127

22K TO 47K PULL-UPS MUST BE PLACED ON INTA#, PME#, SERIRQ# & CLKRUN#.

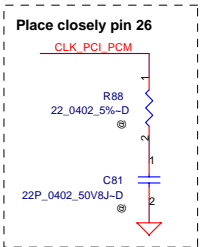

PROPRIETARY NOTE: THIS SHEET OF ENGINEERING DRAWING AND SPECIFICATIONS CONTAINS CONFIDENTIAL TRADE SECRET AND OTHER PROPRIETARY INFORMATION OF DELL INC. ("DELL"). THIS DOCUMENT MAY NOT BE TRANSFERRED OR COPIED WITHOUT THE EXPRESS WRITTEN AUTHORIZATION OF DELL. IN ADDITION, NEITHER THIS SHEET NOR THE INFORMATION IT CONTAINS MAY BE USED BY OR DISCLOSED TO ANY THIRD PARTY WITHOUT DELL'S EXPRESS WRITTEN CONSENT.

DELL CONFIDENTIAL/PROPRIETARY

Title: **Card Bus OZ601**

Size: Document Number

Rev: 1.0

LA-2792

Date: Thursday, February 09, 2006 Sheet 30 of 70

USB SMARTCARD READER.
 TYPE A (5V), B (3V), AB (5V/3V)
 & USB SMARTCARDS ARE SUPPORTED.

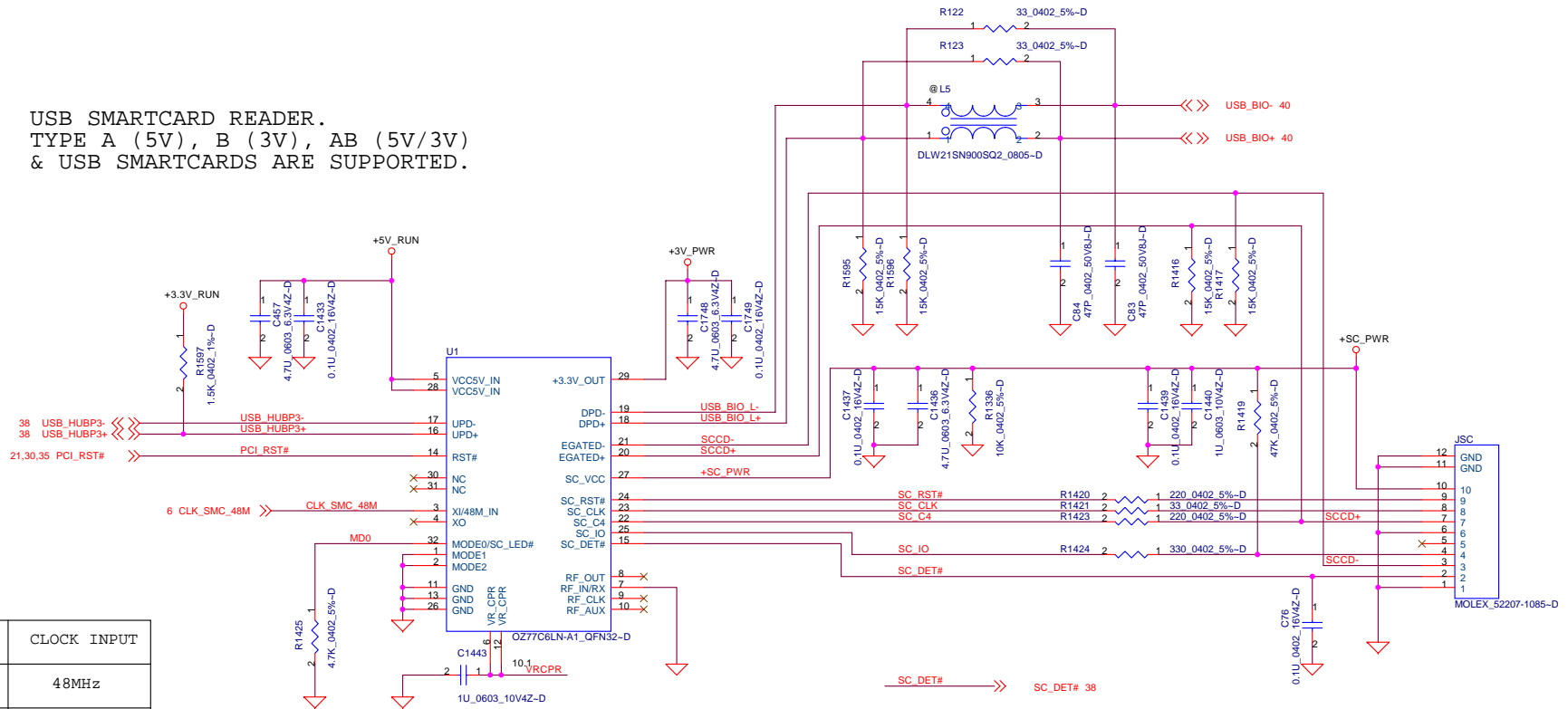

MODE1	CLOCK INPUT
LOW	48MHz
HIGH	6MHz Crystal

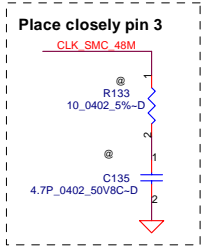

PROPRIETARY NOTE: THIS SHEET OF ENGINEERING DRAWING AND SPECIFICATIONS CONTAINS CONFIDENTIAL TRADE SECRET AND OTHER PROPRIETARY INFORMATION OF DELL INC. ("DELL"). THIS DOCUMENT MAY NOT BE TRANSFERRED OR COPIED WITHOUT THE EXPRESS WRITTEN AUTHORIZATION OF DELL. IN ADDITION, NEITHER THIS SHEET NOR THE INFORMATION IT CONTAINS MAY BE USED BY OR DISCLOSED TO ANY THIRD PARTY WITHOUT DELL'S EXPRESS WRITTEN CONSENT.



DELL CONFIDENTIAL/PROPRIETARY

Compal Electronics, Inc.

Smart Card OZ77C6

LA-2792

Thursday, February 09, 2006 Sheet 31 of 70

Rev 1.0

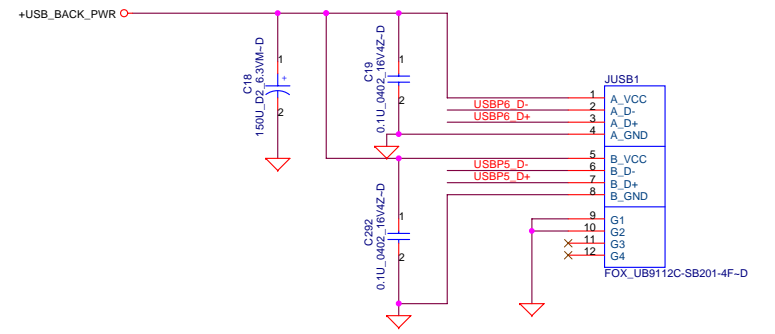
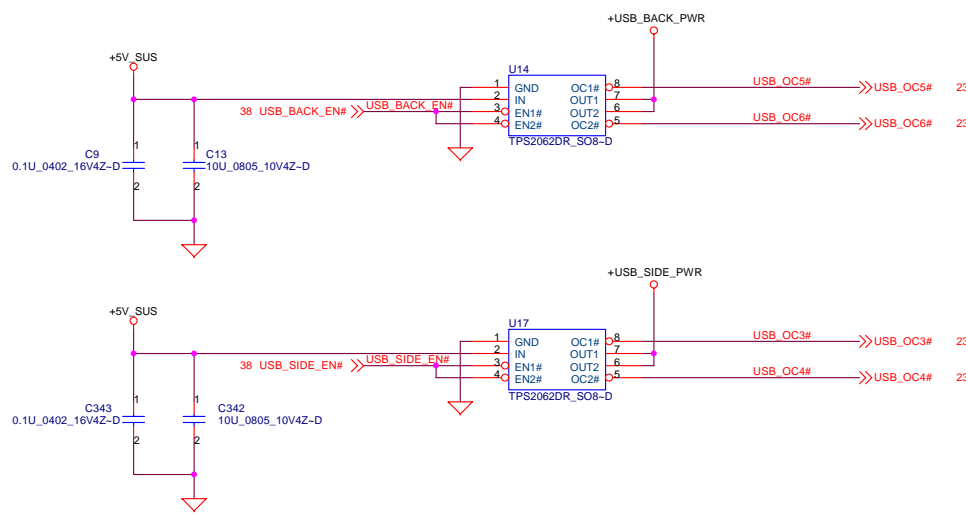
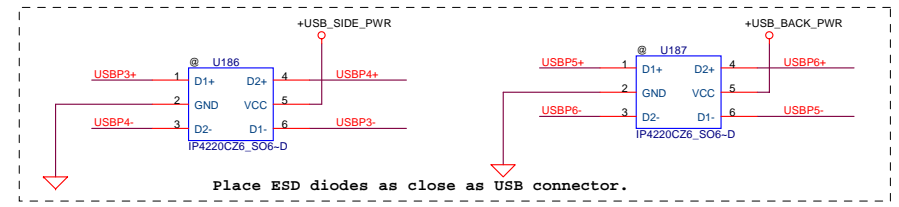
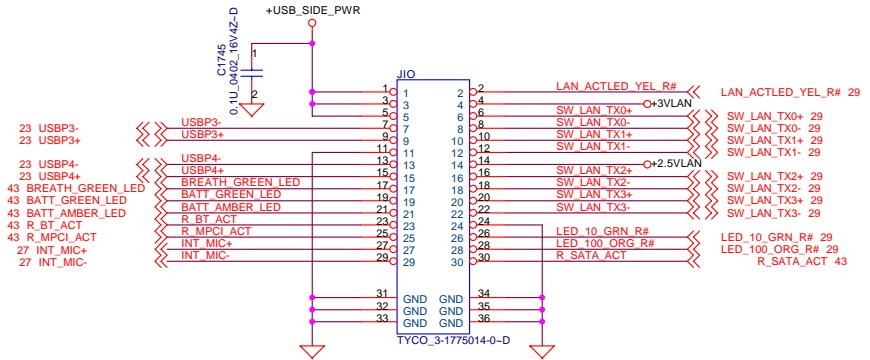
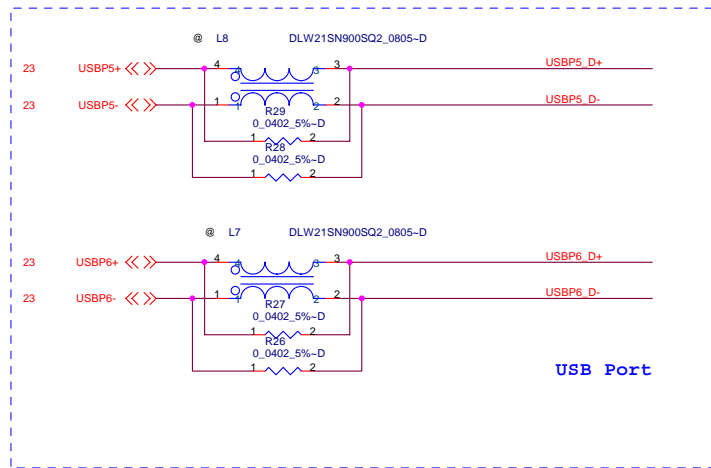

Rear USB Ports

DELL CONFIDENTIAL/PROPRIETARY

Compal Electronics, Inc.

USB 2.0 Port

Title: LA-2792
 Size: Document Number
 Date: Thursday, February 09, 2006 Sheet 32 of 70

PROPRIETARY NOTE: THIS SHEET OF ENGINEERING DRAWING AND SPECIFICATIONS CONTAINS CONFIDENTIAL TRADE SECRET AND OTHER PROPRIETARY INFORMATION OF DELL INC. ("DELL"). THIS DOCUMENT MAY NOT BE TRANSFERRED OR COPIED WITHOUT THE EXPRESS WRITTEN AUTHORIZATION OF DELL. IN ADDITION, NEITHER THIS SHEET NOR THE INFORMATION IT CONTAINS MAY BE USED BY OR DISCLOSED TO ANY THIRD PARTY WITHOUT DELL'S EXPRESS WRITTEN CONSENT.



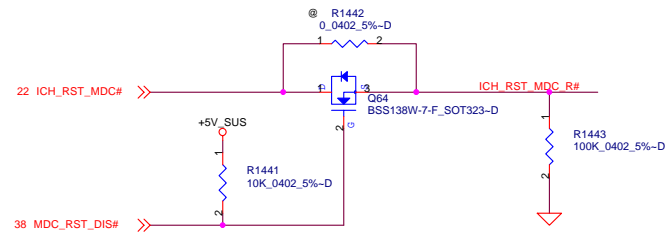

New MDC connector.

1	GND	RES	2
3	IAC_SDATA0	RES	4
5	GND	3.3V	6
7	IAC_SYNC	GND	8
9	IAC_SDATAIN	GND	10
11	IAC_RESET#	IAC_BITCLK	12

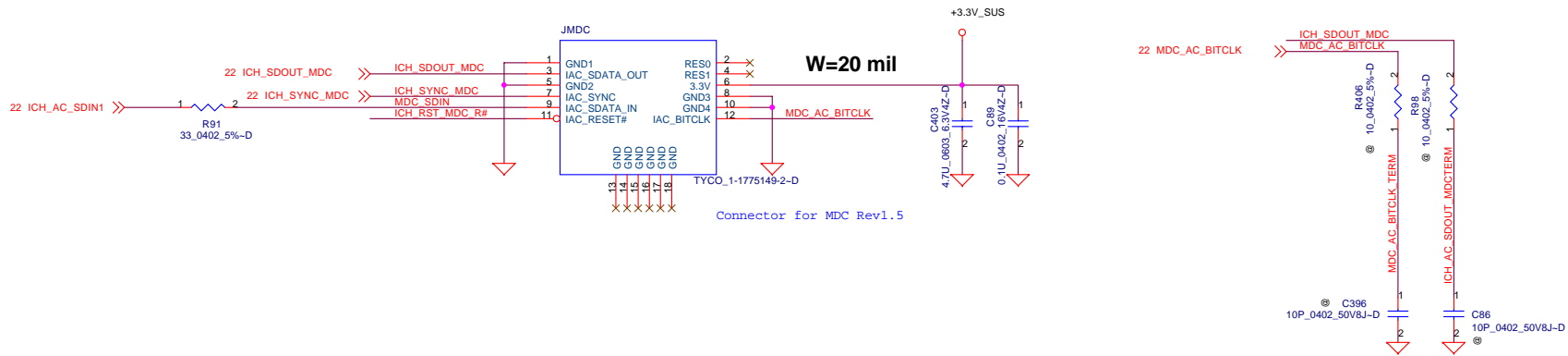

PROPRIETARY NOTE: THIS SHEET OF ENGINEERING DRAWING AND SPECIFICATIONS CONTAINS CONFIDENTIAL TRADE SECRET AND OTHER PROPRIETARY INFORMATION OF DELL INC. ("DELL"). THIS DOCUMENT MAY NOT BE TRANSMITTED OR COPIED WITHOUT THE EXPRESS WRITTEN AUTHORIZATION OF DELL. IN ADDITION, NEITHER THIS SHEET NOR THE INFORMATION IT CONTAINS MAY BE USED BY OR DISCLOSED TO ANY THIRD PARTY WITHOUT DELL'S EXPRESS WRITTEN CONSENT.



DELL CONFIDENTIAL/PROPRIETARY

Compal Electronics, Inc.		
Title		
BT PORT and MDC		
Size	Document Number	Rev
	LA-2792	1.0
Date:	Thursday, February 09, 2006	Sheet 33 of 70

Mini Card Wire less WAN

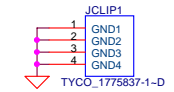

Mini-Card Latch

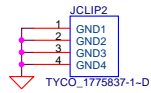
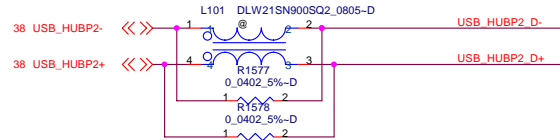

Mini-Card Latch

Mini Card Wire less LAN

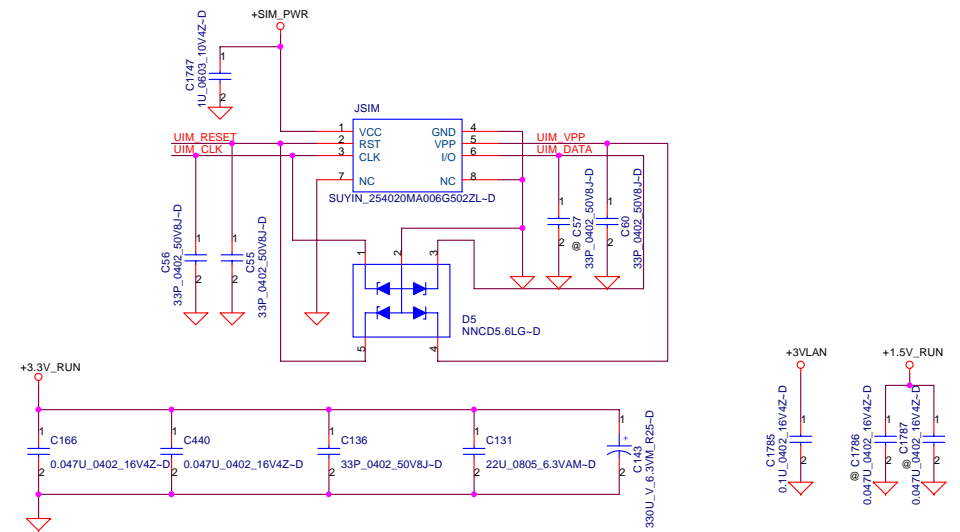
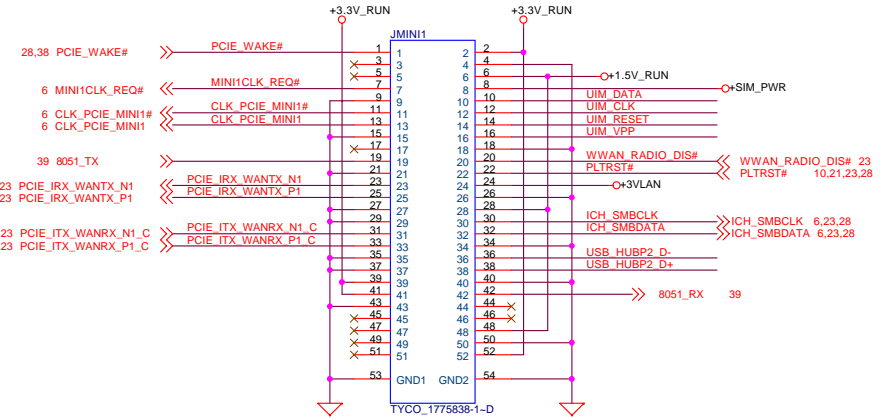
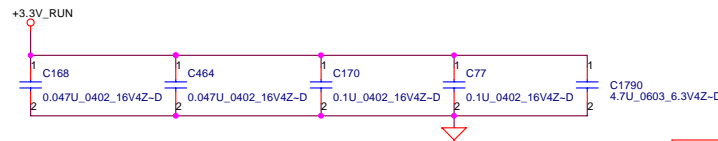
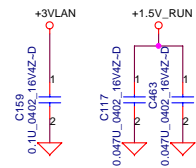
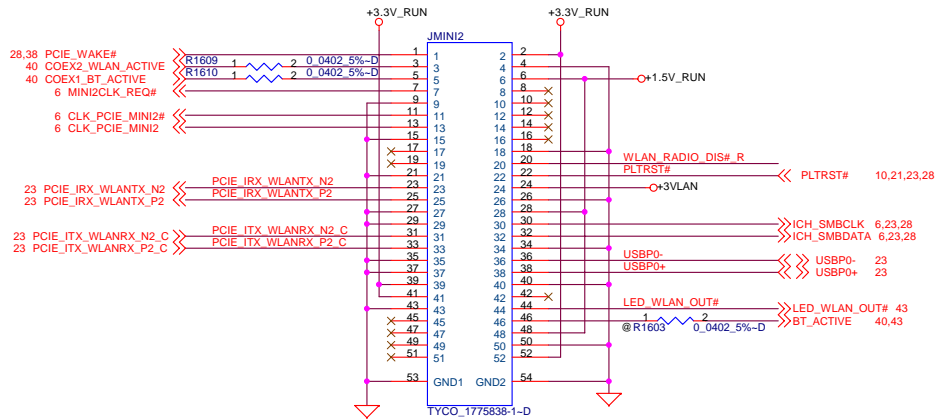

PWR Rail	Voltage Tolerance	Primary Power		Aux Power
		Peak	Normal	Normal
+3.3V	+9%	1000	750	
+3.3Vaux	+9%	330	250	250 (Wake enable) 5 (Not wake enable)
+1.5V	+5%	500	375	NA

PROPRIETARY NOTE: THIS SHEET OF ENGINEERING DRAWING AND SPECIFICATIONS CONTAINS CONFIDENTIAL TRADE SECRET AND OTHER PROPRIETARY INFORMATION OF DELL INC. ("DELL"). THIS DOCUMENT MAY NOT BE TRANSMITTED OR COPIED WITHOUT THE EXPRESS WRITTEN AUTHORIZATION OF DELL. IN ADDITION, NEITHER THIS SHEET NOR THE INFORMATION IT CONTAINS MAY BE USED BY OR DISCLOSED TO ANY THIRD PARTY WITHOUT DELL'S EXPRESS WRITTEN CONSENT.



DELL CONFIDENTIAL/PROPRIETARY

Compal Electronics, Inc.

Title			
Mini Card			
Size	Document Number	Rev	
	LA-2792	1.0	
Date:	Thursday, February 09, 2006	Sheet	34 of 70

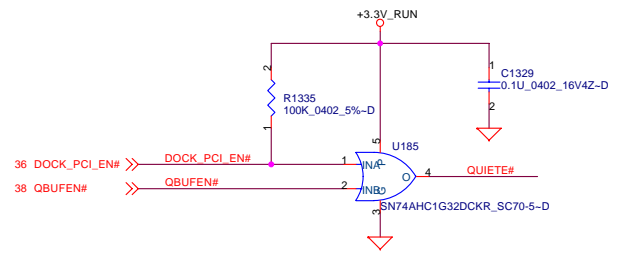
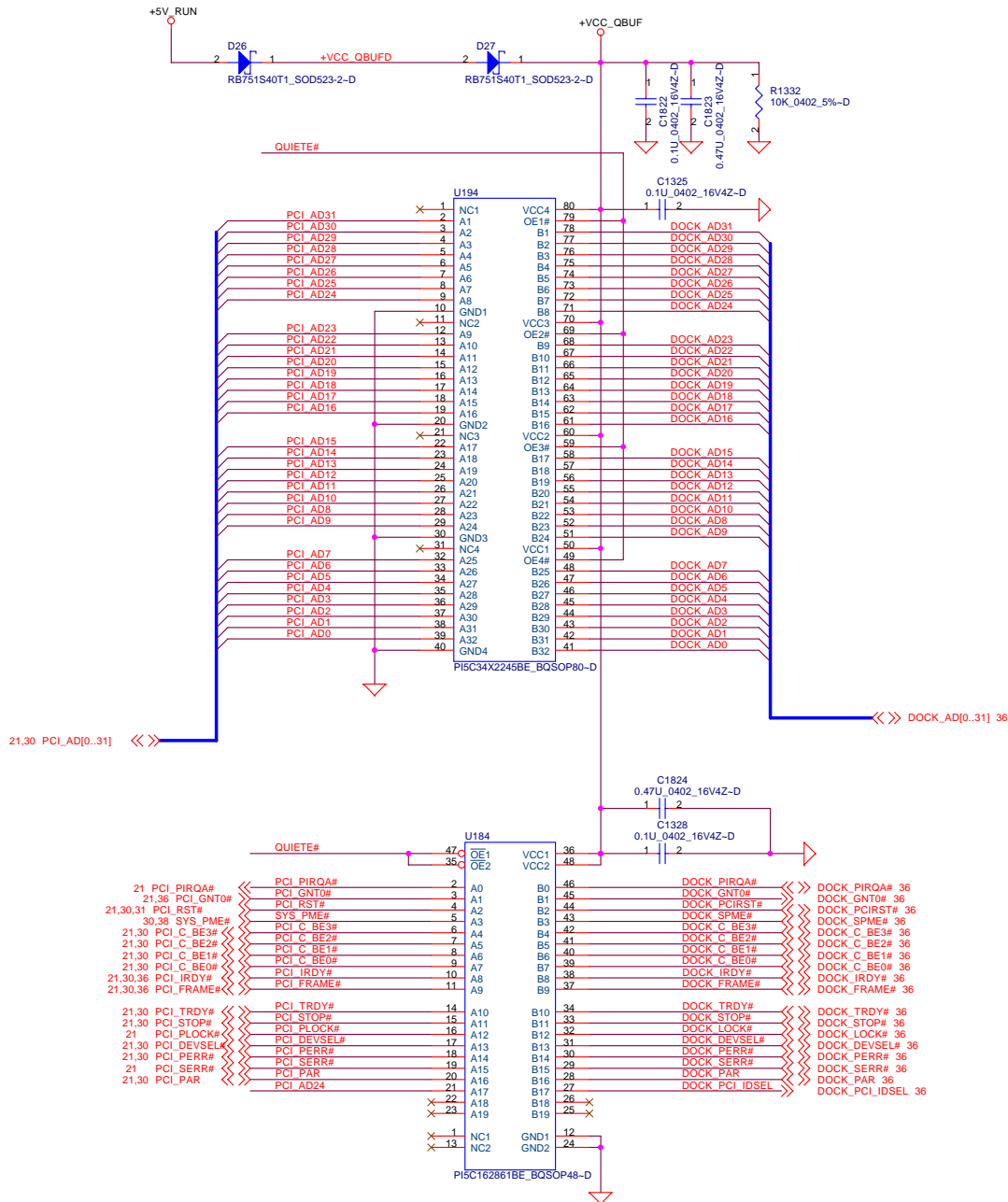

PROPRIETARY NOTE: THIS SHEET OF ENGINEERING DRAWING AND SPECIFICATIONS CONTAINS CONFIDENTIAL TRADE SECRET AND OTHER PROPRIETARY INFORMATION OF DELL INC. ("DELL"). THIS DOCUMENT MAY NOT BE TRANSFERRED OR COPIED WITHOUT THE EXPRESS WRITTEN AUTHORIZATION OF DELL. IN ADDITION, NEITHER THIS SHEET NOR THE INFORMATION IT CONTAINS MAY BE USED BY OR DISCLOSED TO ANY THIRD PARTY WITHOUT DELL'S EXPRESS WRITTEN CONSENT.

	DELL CONFIDENTIAL/PROPRIETARY		
	DOCKING BUFFER		
	Size	Document Number	Rev
	LA-2792		1.0
Date:	Thursday, February 09, 2006	Sheet	35 of 70

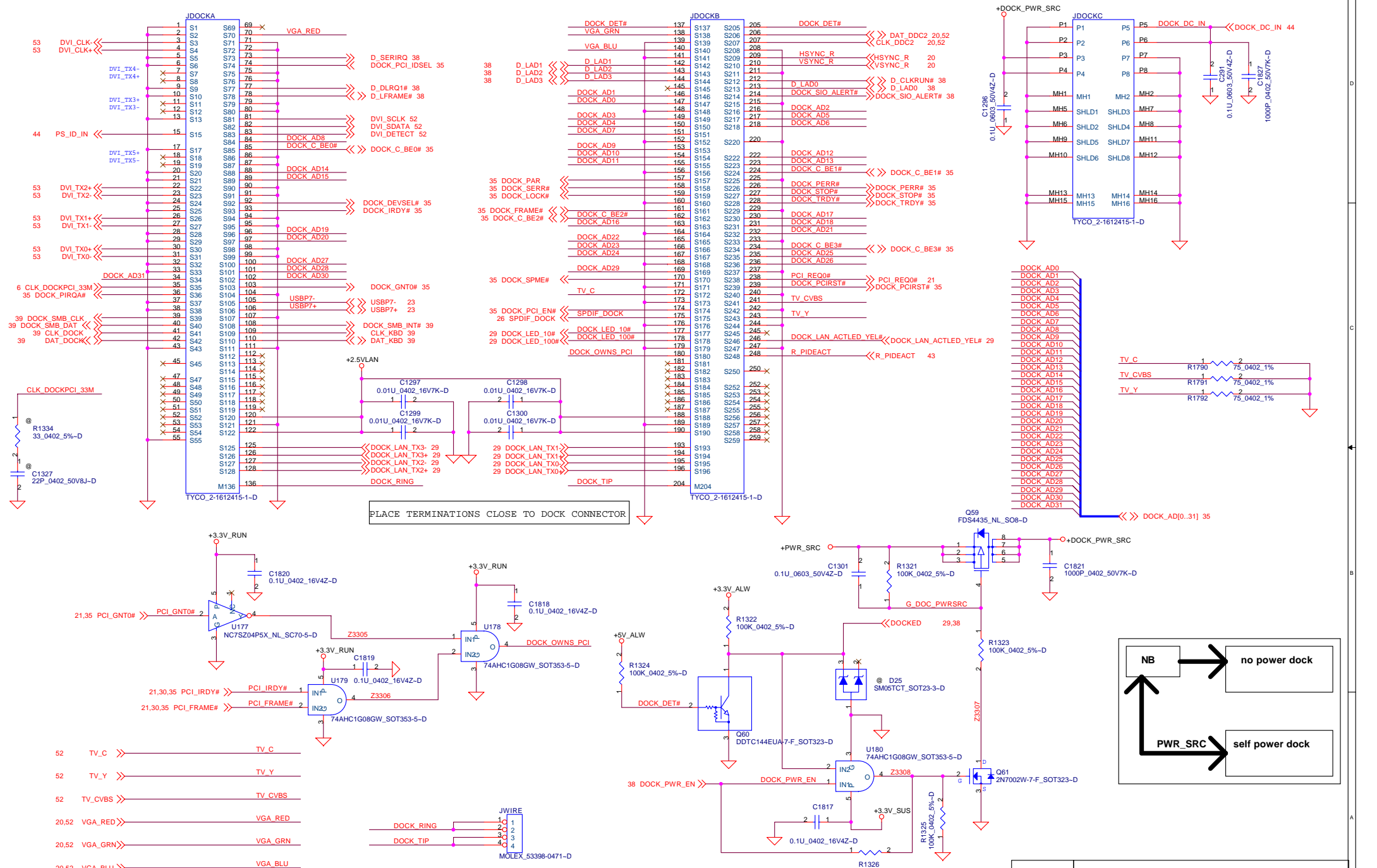

PROPRIETARY NOTE: THIS SHEET OF ENGINEERING DRAWING AND SPECIFICATIONS CONTAINS CONFIDENTIAL TRADE SECRET AND OTHER PROPRIETARY INFORMATION OF DELL INC. ("DELL"). THIS DOCUMENT MAY NOT BE TRANSFERRED OR COPIED WITHOUT THE EXPRESS WRITTEN AUTHORIZATION OF DELL. IN ADDITION, NEITHER THIS SHEET NOR THE INFORMATION IT CONTAINS MAY BE USED BY OR DISCLOSED TO ANY THIRD PARTY WITHOUT DELL'S EXPRESS WRITTEN CONSENT.

		DELL CONFIDENTIAL/PROPRIETARY	
		Title: DOCKING CONN.	
Size	Document Number		Rev
	LA-2792		1.0
Date:	Thursday, February 09, 2006	Sheet	36 of 70

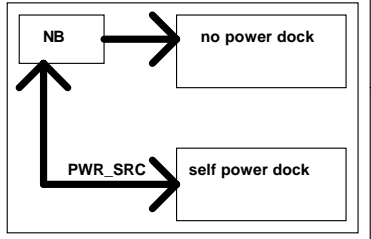

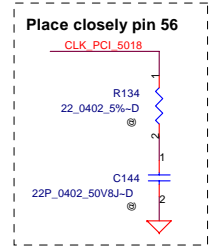
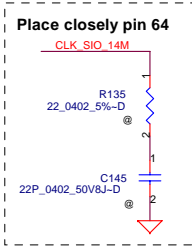
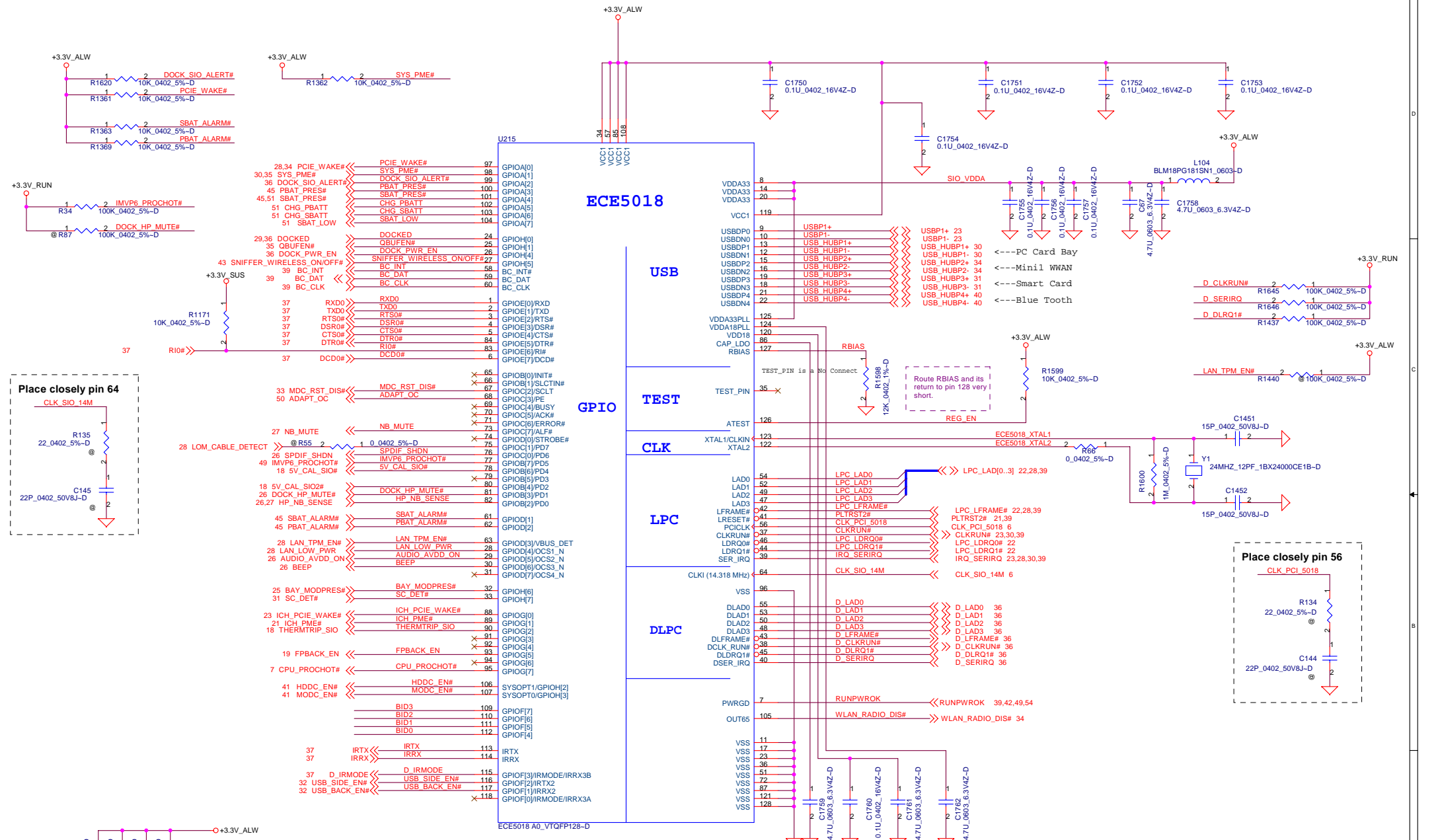

BID3	BID2	BID1	BID0	REV
0	0	0	0	M00
0	0	0	1	M01
0	0	1	0	X00
0	0	1	1	X01
0	1	0	0	X02
0	1	0	1	X03

PROPRIETARY NOTE: THIS SHEET OF ENGINEERING DRAWING AND SPECIFICATIONS CONTAINS CONFIDENTIAL TRADE SECRET AND OTHER PROPRIETARY INFORMATION OF DELL INC. ("DELL"). THIS DOCUMENT MAY NOT BE TRANSMITTED OR COPIED WITHOUT THE EXPRESS WRITTEN AUTHORIZATION OF DELL. IN ADDITION, NEITHER THIS SHEET NOR THE INFORMATION IT CONTAINS MAY BE USED BY OR DISCLOSED TO ANY THIRD PARTY WITHOUT DELL'S EXPRESS WRITTEN CONSENT.



DELL CONFIDENTIAL/PROPRIETARY

Compal Electronics, Inc.

Title			ECE5018		
Size	Document Number		Rev		
	LA-2792		1.0		
Date:	Thursday, February 09, 2006	Sheet	38	of	70

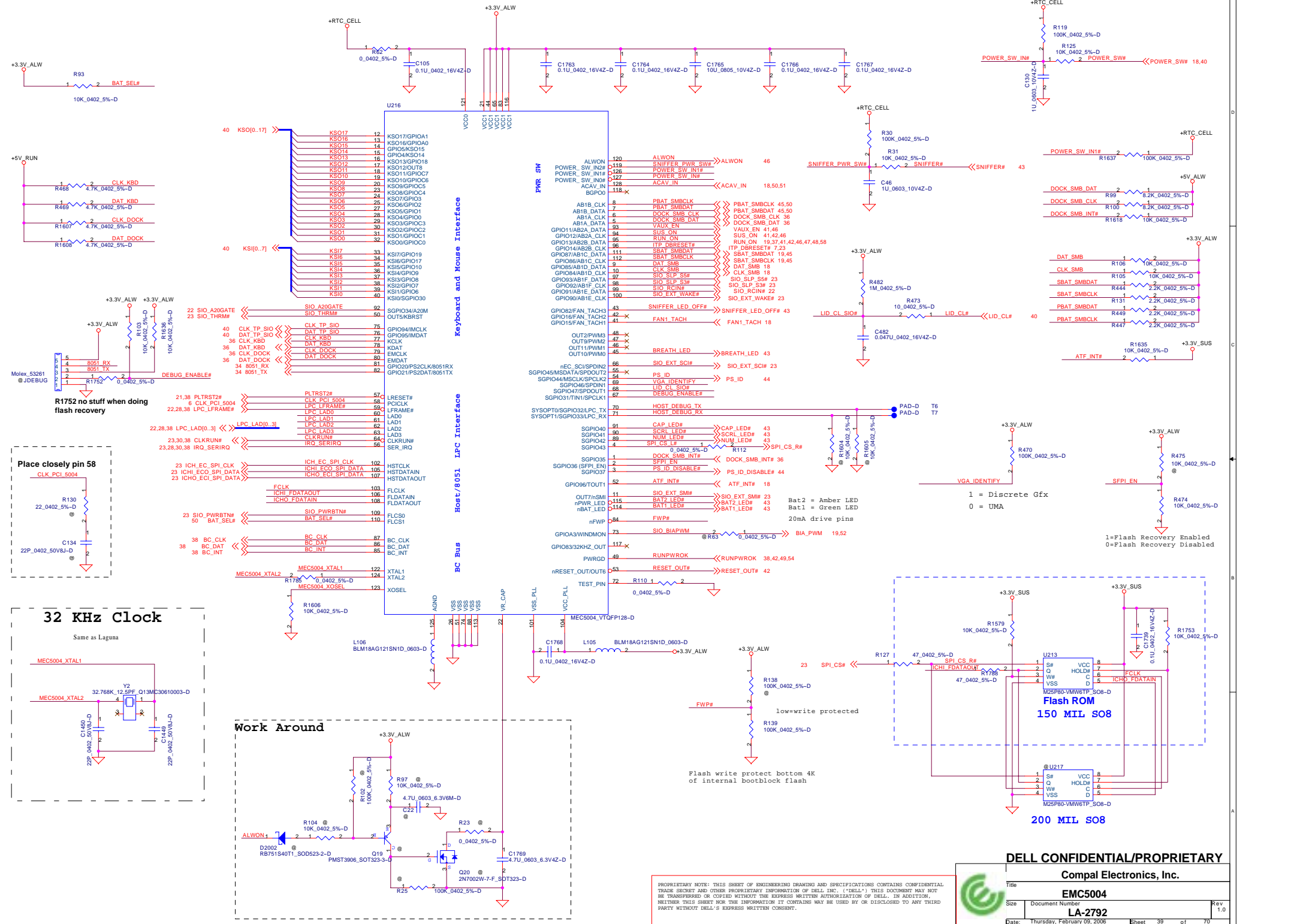

PROPRIETARY NOTE: THIS SHEET OF ENGINEERING DRAWING AND SPECIFICATIONS CONTAINS CONFIDENTIAL AND PROPRIETARY INFORMATION OF DELL EMC. ("DELL") THIS DOCUMENT MAY NOT BE TRANSMITTED OR COPIED WITHOUT THE EXPRESS WRITTEN AUTHORIZATION OF DELL. IN ADDITION, NEITHER THIS SHEET NOR THE INFORMATION IT CONTAINS MAY BE USED BY OR DISCLOSED TO ANY THIRD PARTY WITHOUT DELL'S EXPRESS WRITTEN CONSENT.

DELL CONFIDENTIAL/PROPRIETARY

Compal Electronics, Inc.

EMC5004

LA-2792

Date: Thursday, February 09, 2006 Sheet 39 of 70

Touch PAD

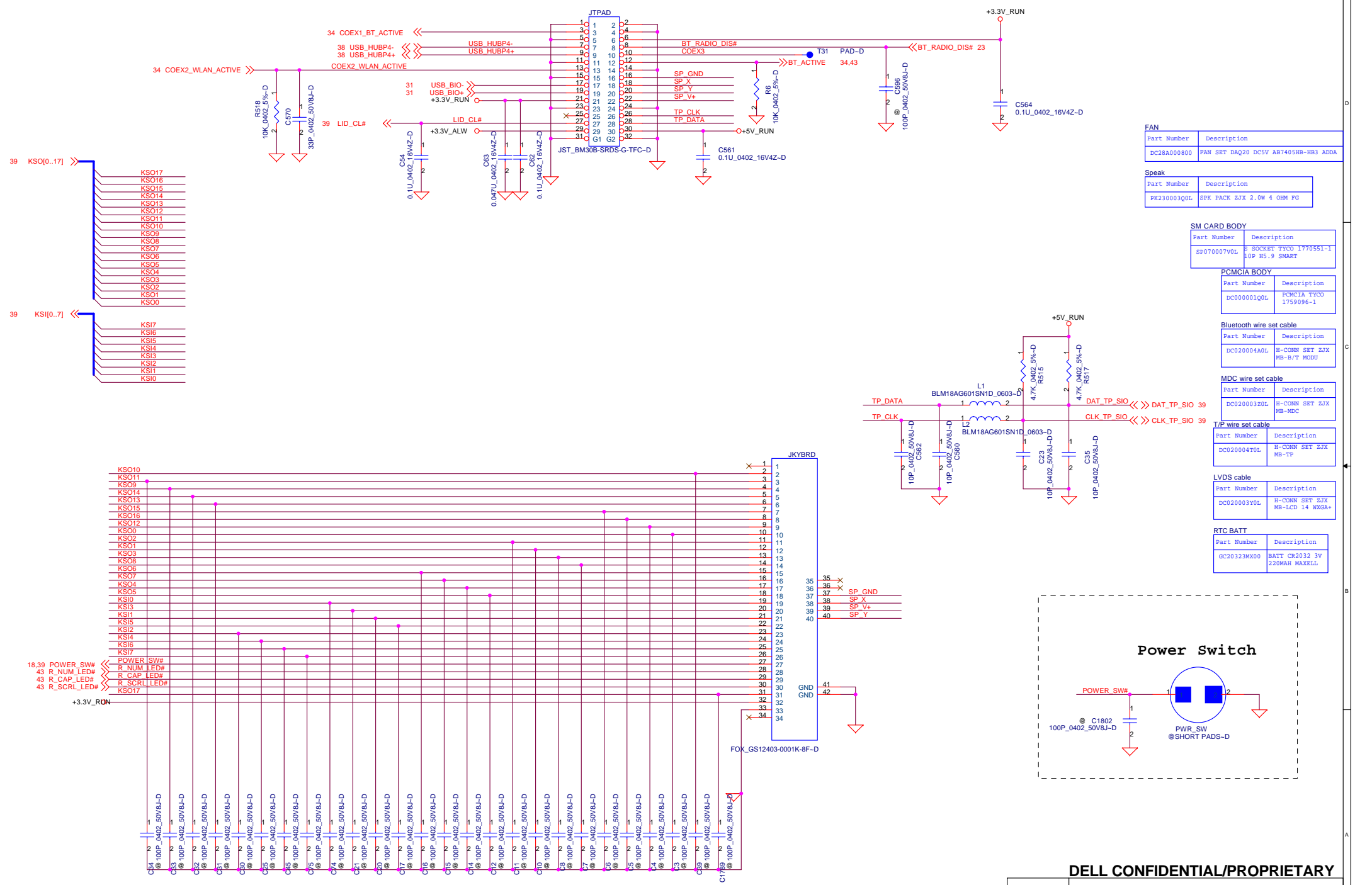

FAN	
Part Number	Description
DC28A000800	FAN SET DAQ20 DC5V AB7405HB-HB3 ADDA

Speak	
Part Number	Description
PK230003Q0L	SPK PACK ZJX 2.0W 4 OHM FG

SM CARD BODY	
Part Number	Description
SP070007V0L	S SOCKET TYCO 1779551-1 10P H5.9 SMART

PCMCIA BODY	
Part Number	Description
DC000001Q0L	PCMCIA TYCO 1759096-1

Bluetooth wire set cable	
Part Number	Description
DC020004A0L	H-CONN SET ZJX MB-B/T MODU

MDC wire set cable	
Part Number	Description
DC020003Z0L	H-CONN SET ZJX MB-MDC

T/P wire set cable	
Part Number	Description
DC020004T0L	H-CONN SET ZJX MB-TP

LVDS cable	
Part Number	Description
DC020003Y0L	H-CONN SET ZJX MB-LCD 14 WXGA+

RTC BATT	
Part Number	Description
GC2032MX00	BATT CR2032 3V 220MAH MAXELL

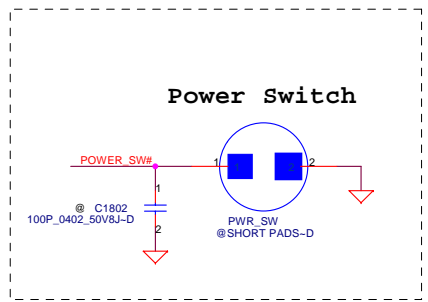

DELL CONFIDENTIAL/PROPRIETARY

Compal Electronics, Inc.

INT KB		
Title	LA-2792	
Size	Document Number	Rev 1.0
Date: Thursday, February 09, 2006	Sheet 40	of 70

PROPRIETARY NOTE: THIS SHEET OF ENGINEERING DRAWING AND SPECIFICATIONS CONTAINS CONFIDENTIAL TRADE SECRET AND OTHER PROPRIETARY INFORMATION OF DELL INC. ("DELL"). THIS DOCUMENT MAY NOT BE TRANSMITTED OR COPIED WITHOUT THE EXPRESS WRITTEN AUTHORIZATION OF DELL. IN ADDITION, NEITHER THIS SHEET NOR THE INFORMATION IT CONTAINS MAY BE USED BY OR DISCLOSED TO ANY THIRD PARTY WITHOUT DELL'S EXPRESS WRITTEN CONSENT.

DC/DC Interface

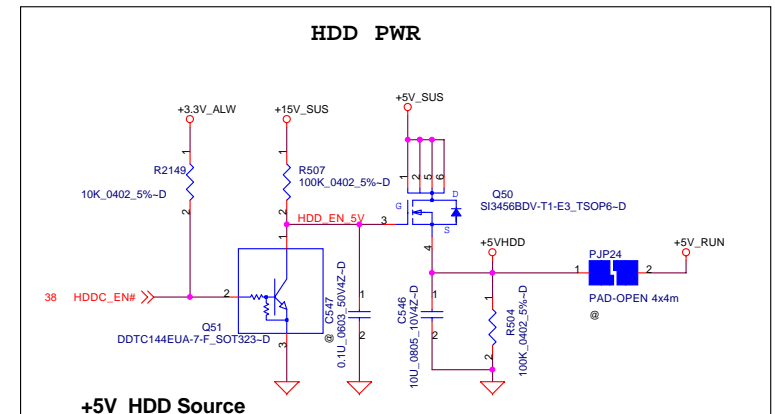
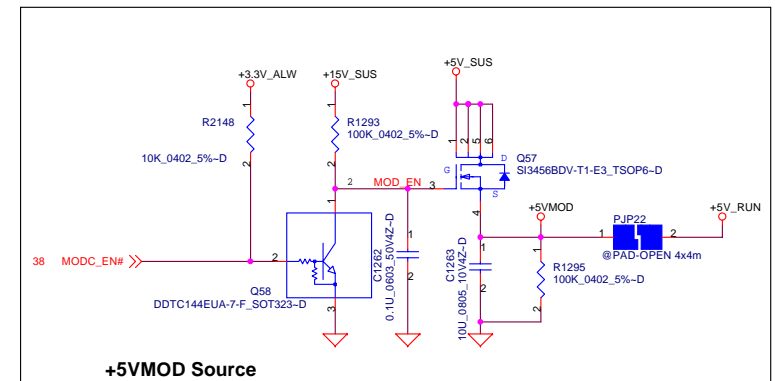
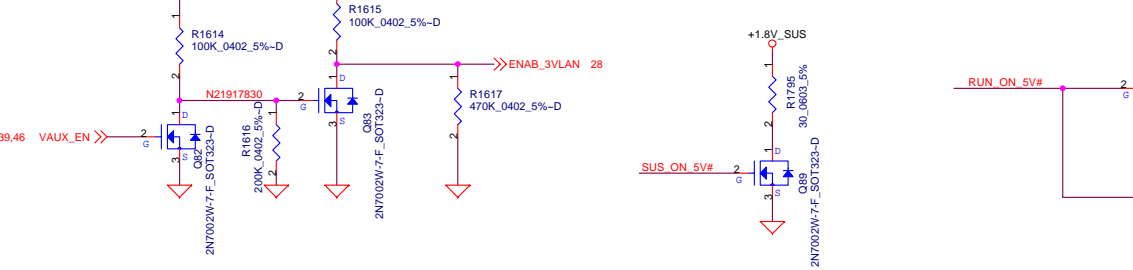
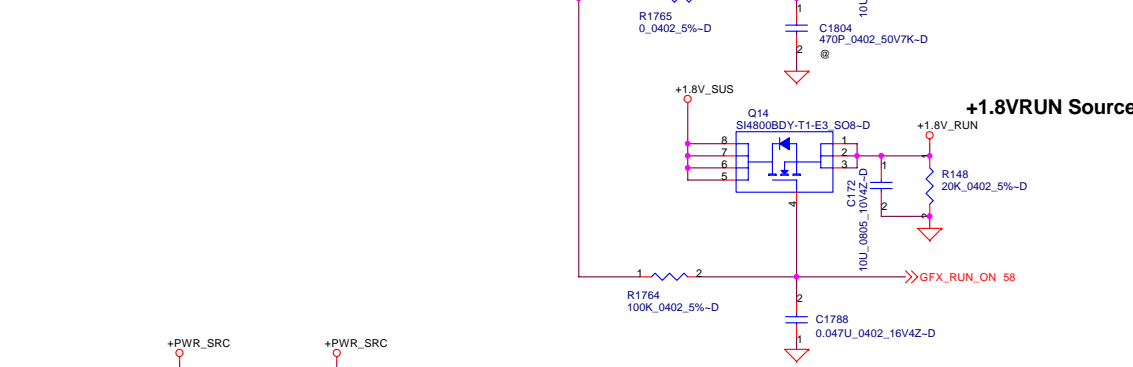
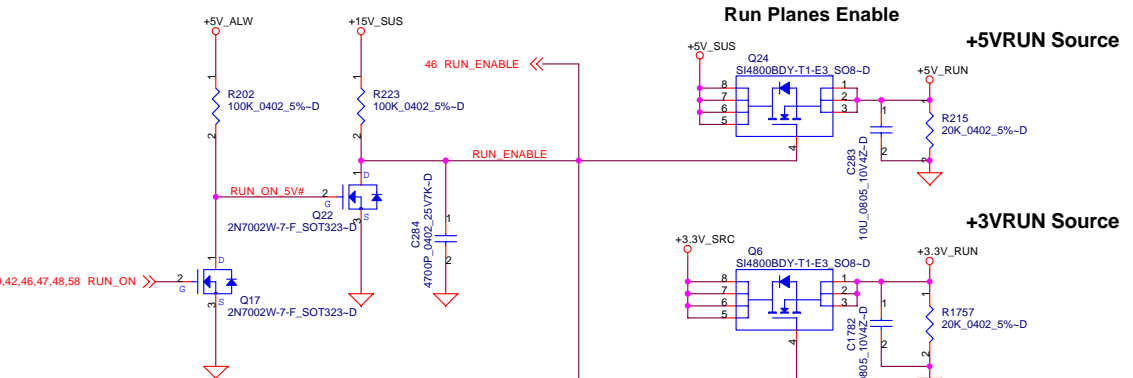
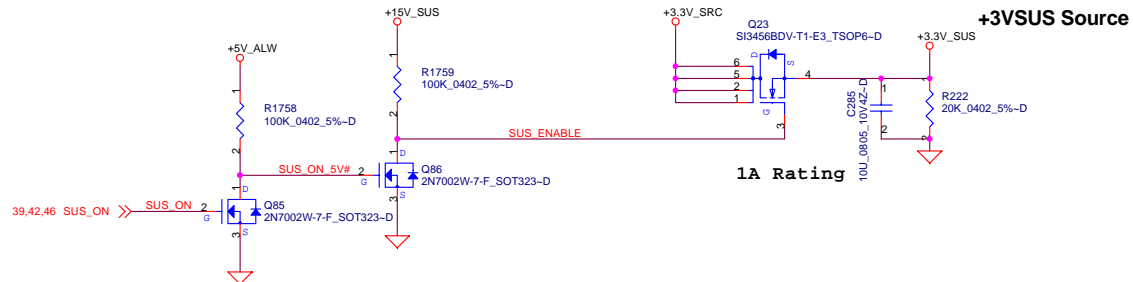

Discharg Circuit

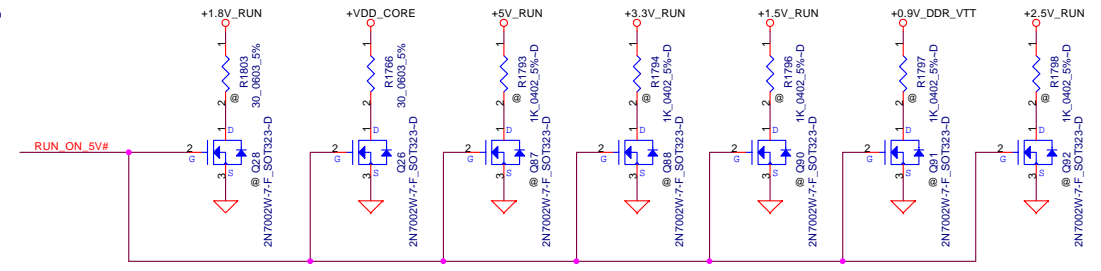

DELL CONFIDENTIAL/PROPRIETARY

Compal Electronics, Inc.

POWER CONTROL

Title	LA-2792		
Size	Document Number		Rev 1.0
Date	Thursday, February 09, 2006	Sheet 41	of 70

PROPRIETARY NOTE: THIS SHEET OF ENGINEERING DRAWING AND SPECIFICATIONS CONTAINS CONFIDENTIAL TRADE SECRET AND OTHER PROPRIETARY INFORMATION OF DELL INC. ("DELL"). THIS DOCUMENT MAY NOT BE TRANSMITTED OR COPIED WITHOUT THE EXPRESS WRITTEN AUTHORIZATION OF DELL. IN ADDITION, NEITHER THIS SHEET NOR THE INFORMATION IT CONTAINS MAY BE USED BY OR DISCLOSED TO ANY THIRD PARTY WITHOUT DELL'S EXPRESS WRITTEN CONSENT.

For EMI

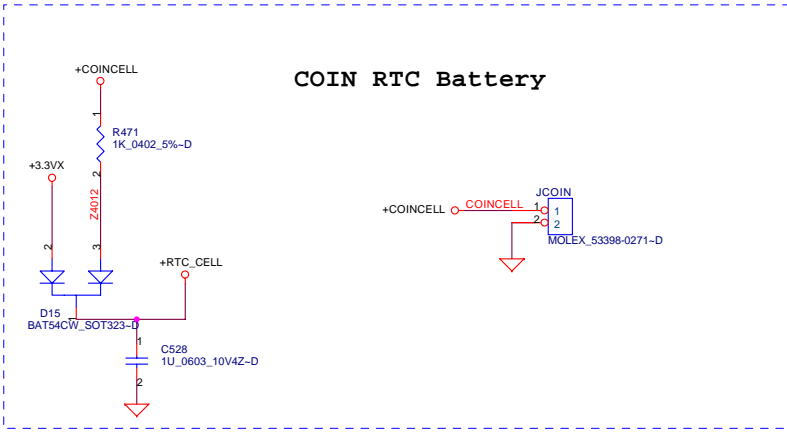
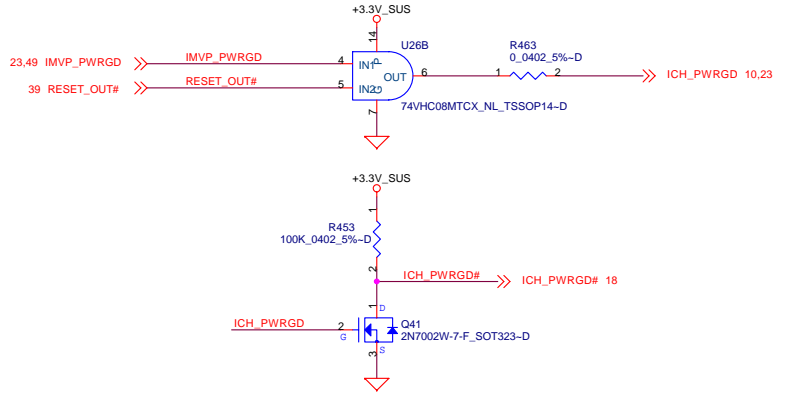
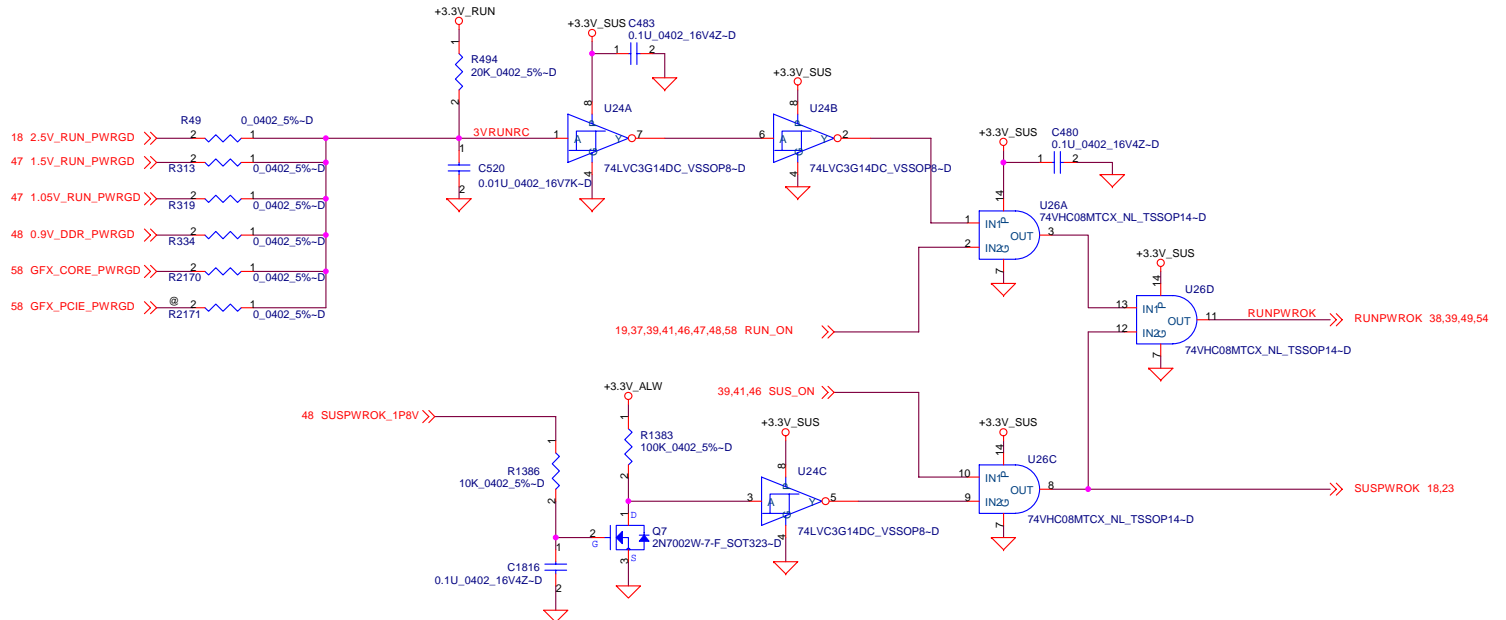
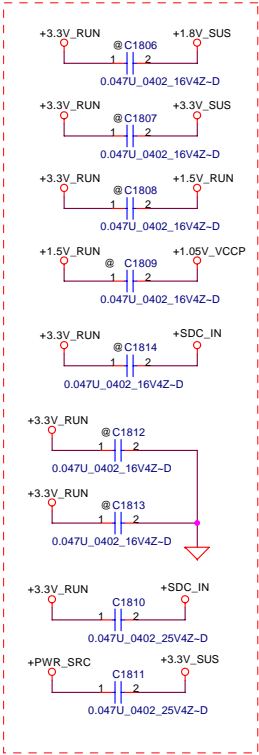

PROPRIETARY NOTE: THIS SHEET OF ENGINEERING DRAWING AND SPECIFICATIONS CONTAINS CONFIDENTIAL TRADE SECRET AND OTHER PROPRIETARY INFORMATION OF DELL INC. ("DELL"). THIS DOCUMENT MAY NOT BE TRANSMITTED OR COPIED WITHOUT THE EXPRESS WRITTEN AUTHORIZATION OF DELL. IN ADDITION, NEITHER THIS SHEET NOR THE INFORMATION IT CONTAINS MAY BE USED BY OR DISCLOSED TO ANY THIRD PARTY WITHOUT DELL'S EXPRESS WRITTEN CONSENT.



DELL CONFIDENTIAL/PROPRIETARY

Compal Electronics, Inc.

Power Good

LA-2792

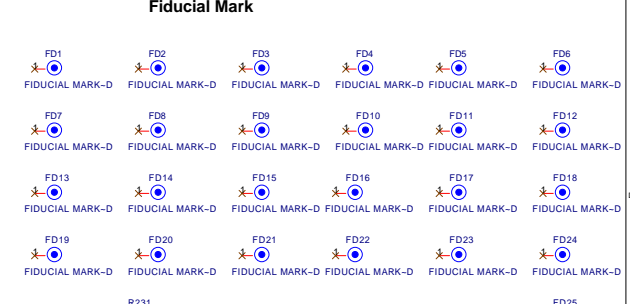
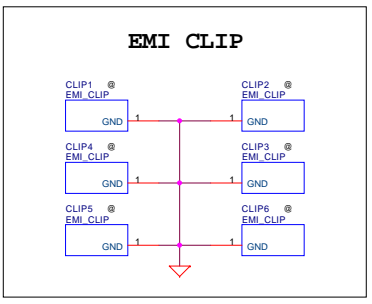
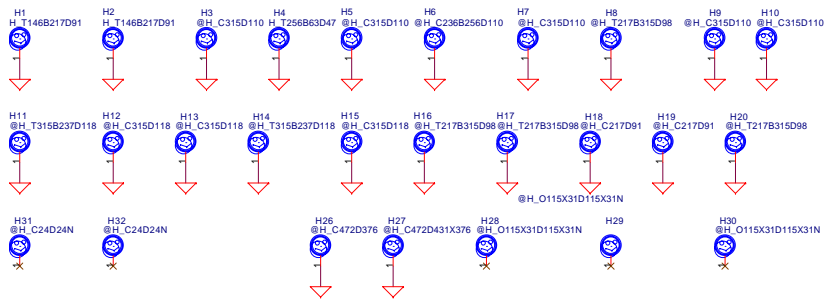

Disable HDD LED

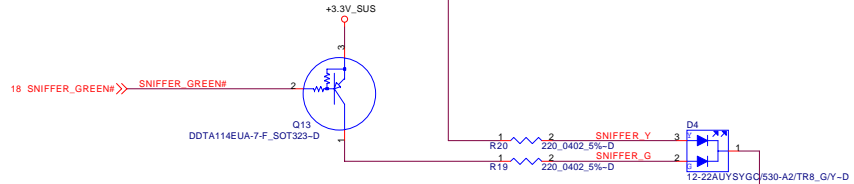
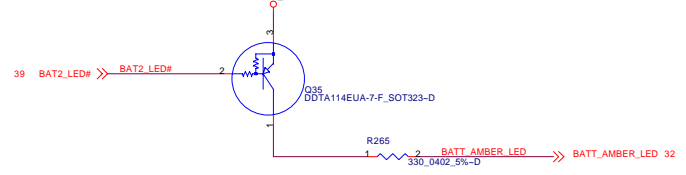
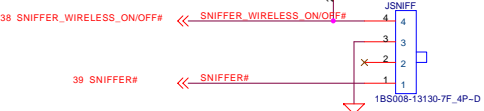
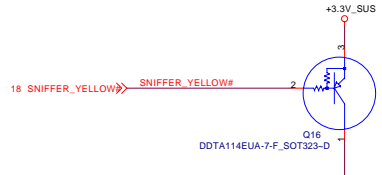
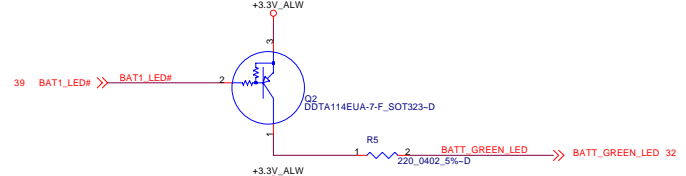
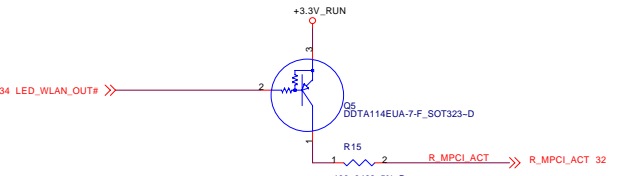
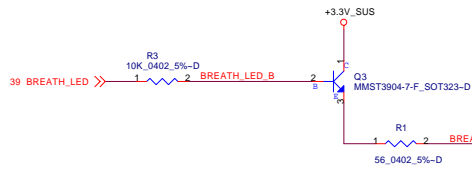
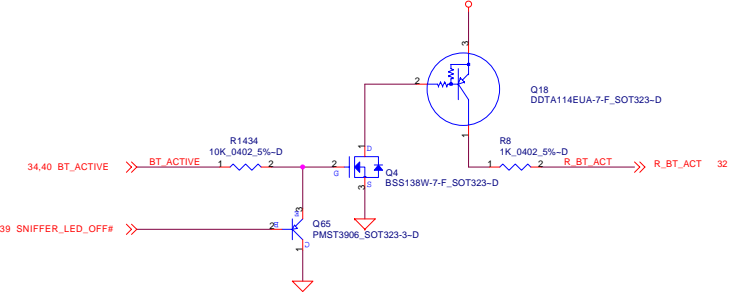
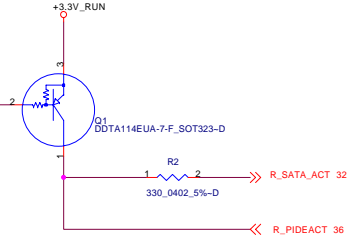
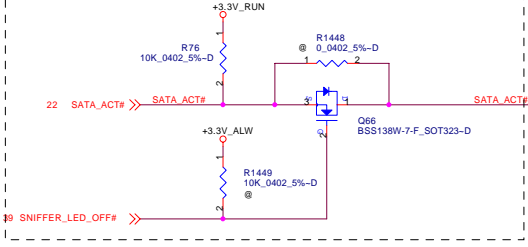

PROPRIETARY NOTE: THIS SHEET OF ENGINEERING DRAWING AND SPECIFICATIONS CONTAINS CONFIDENTIAL TRADE SECRET AND OTHER PROPRIETARY INFORMATION OF DELL INC. ("DELL") THIS DOCUMENT MAY NOT BE TRANSFERRED OR COPIED WITHOUT THE EXPRESS WRITTEN AUTHORIZATION OF DELL. IN ADDITION, NEITHER THIS SHEET NOR THE INFORMATION IT CONTAINS MAY BE USED BY OR DISCLOSED TO ANY THIRD PARTY WITHOUT DELL'S EXPRESS WRITTEN CONSENT.

DELL CONFIDENTIAL/PROPRIETARY

Compal Electronics, Inc.

PAD and Standoff

LA-2792

Date: Thursday, February 09, 2006 Sheet 43 of 70 Rev 1.0

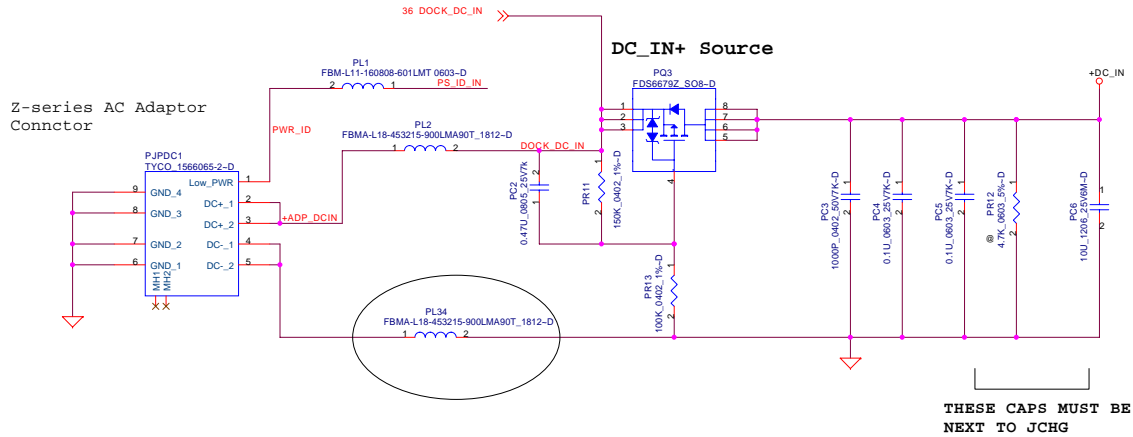
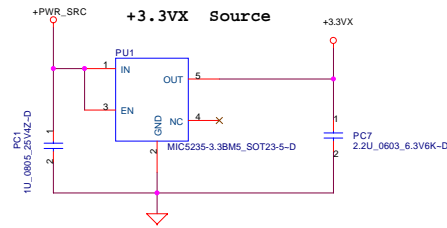
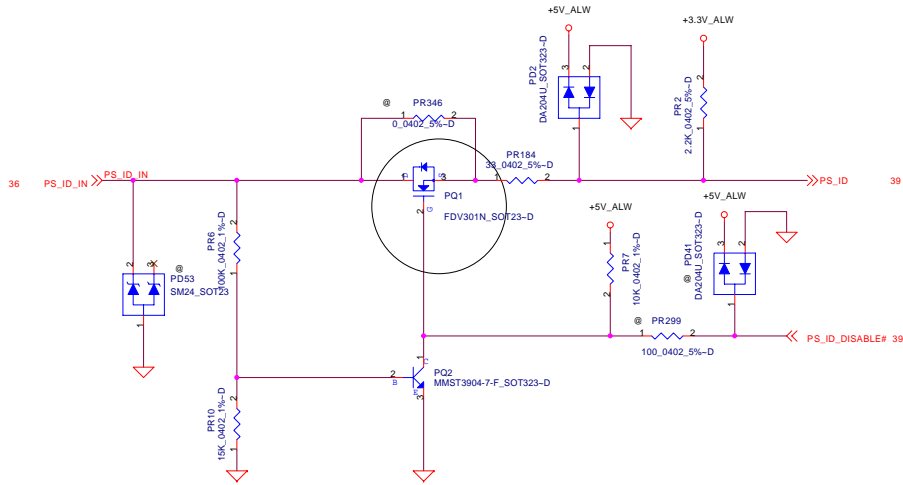

DELL CONFIDENTIAL/PROPRIETARY

Compal Electronics, Inc.

+DCIN

Size	Document Number	Rev
	LA-2792	1.0
Date	Thursday, February 09, 2006	Sheet 44 of 70

THIS SHEET OF ENGINEERING DRAWING IS THE PROPRIETARY PROPERTY OF COMPAL ELECTRONICS, INC. AND CONTAINS CONFIDENTIAL AND TRADE SECRET INFORMATION. THIS SHEET MAY NOT BE TRANSFERRED FROM THE CUSTODY OF THE COMPETENT DIVISION OF R&D DEPARTMENT EXCEPT AS AUTHORIZED BY COMPAL ELECTRONICS, INC. NEITHER THIS SHEET NOR THE INFORMATION IT CONTAINS MAY BE USED BY OR DISCLOSED TO ANY THIRD PARTY WITHOUT PRIOR WRITTEN CONSENT OF COMPAL ELECTRONICS, INC.

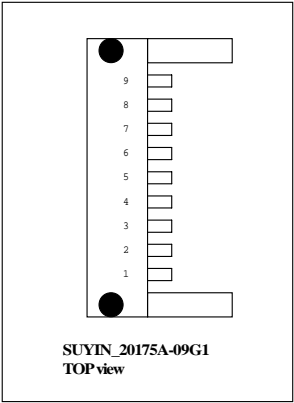
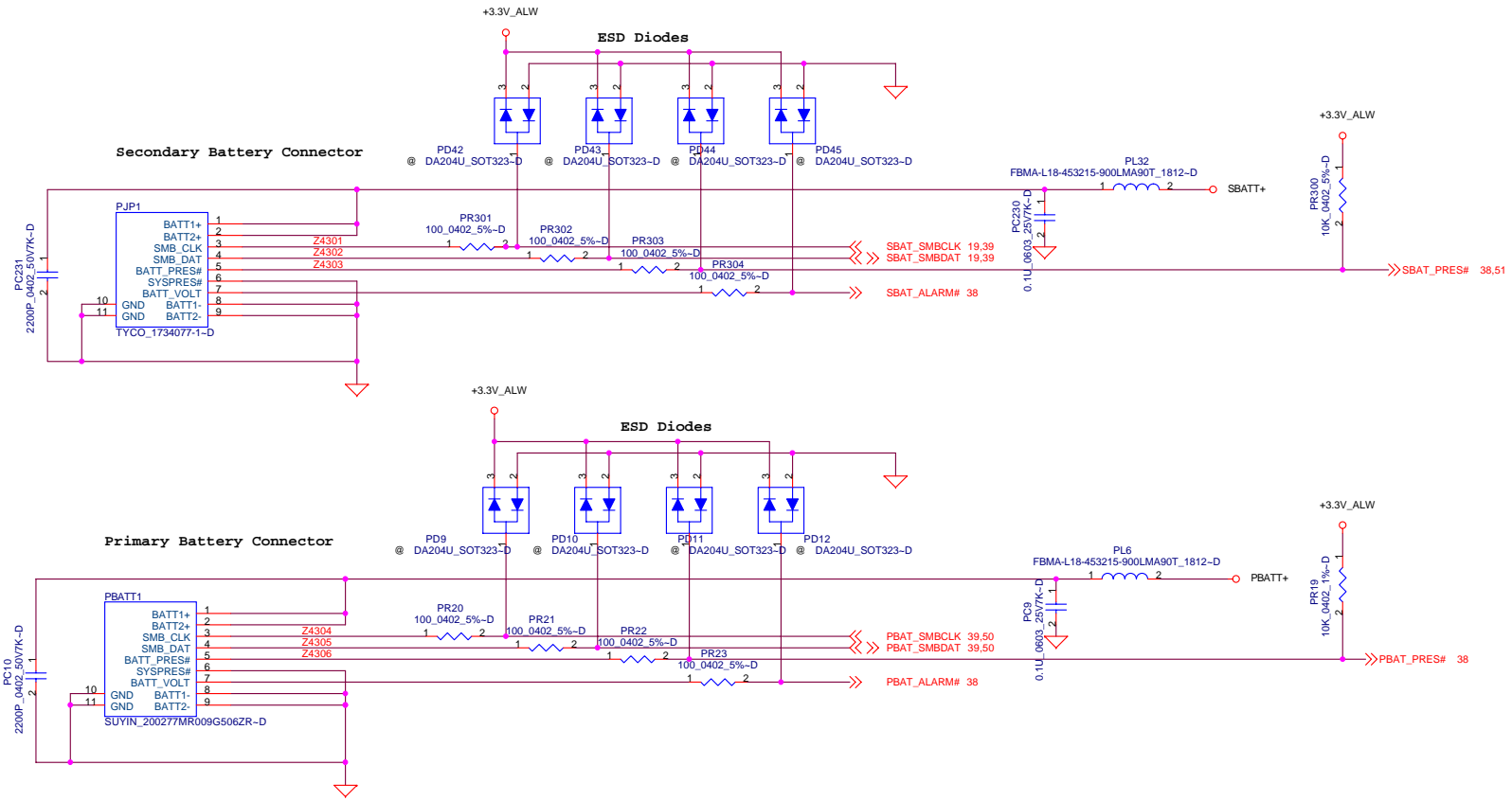

SUYIN_20175A-09G1
TOP view

THIS SHEET OF ENGINEERING DRAWING IS THE PROPRIETARY PROPERTY OF COMPAL ELECTRONICS, INC. AND CONTAINS CONFIDENTIAL AND TRADE SECRET INFORMATION. THIS SHEET MAY NOT BE TRANSFERRED FROM THE CUSTODY OF THE COMPETENT DIVISION OF R&D DEPARTMENT EXCEPT AS AUTHORIZED BY COMPAL ELECTRONICS, INC. NEITHER THIS SHEET NOR THE INFORMATION IT CONTAINS MAY BE USED BY OR DISCLOSED TO ANY THIRD PARTY WITHOUT PRIOR WRITTEN CONSENT OF COMPAL ELECTRONICS, INC.



DELL CONFIDENTIAL/PROPRIETARY

Compal Electronics, Inc.		
Title Battery Conn.		
Size	Document Number LA-2792	Rev 1.0
Date	Thursday, February 09, 2006	Sheet 45 of 70

DC/DC +3V/ +5V/ +15V

Typical:4A
Peak current:8A
OCP point is from 8.2A to 10.5A

Typical:5A
Peak current:7A
OCP point is from 8A to 11.2A

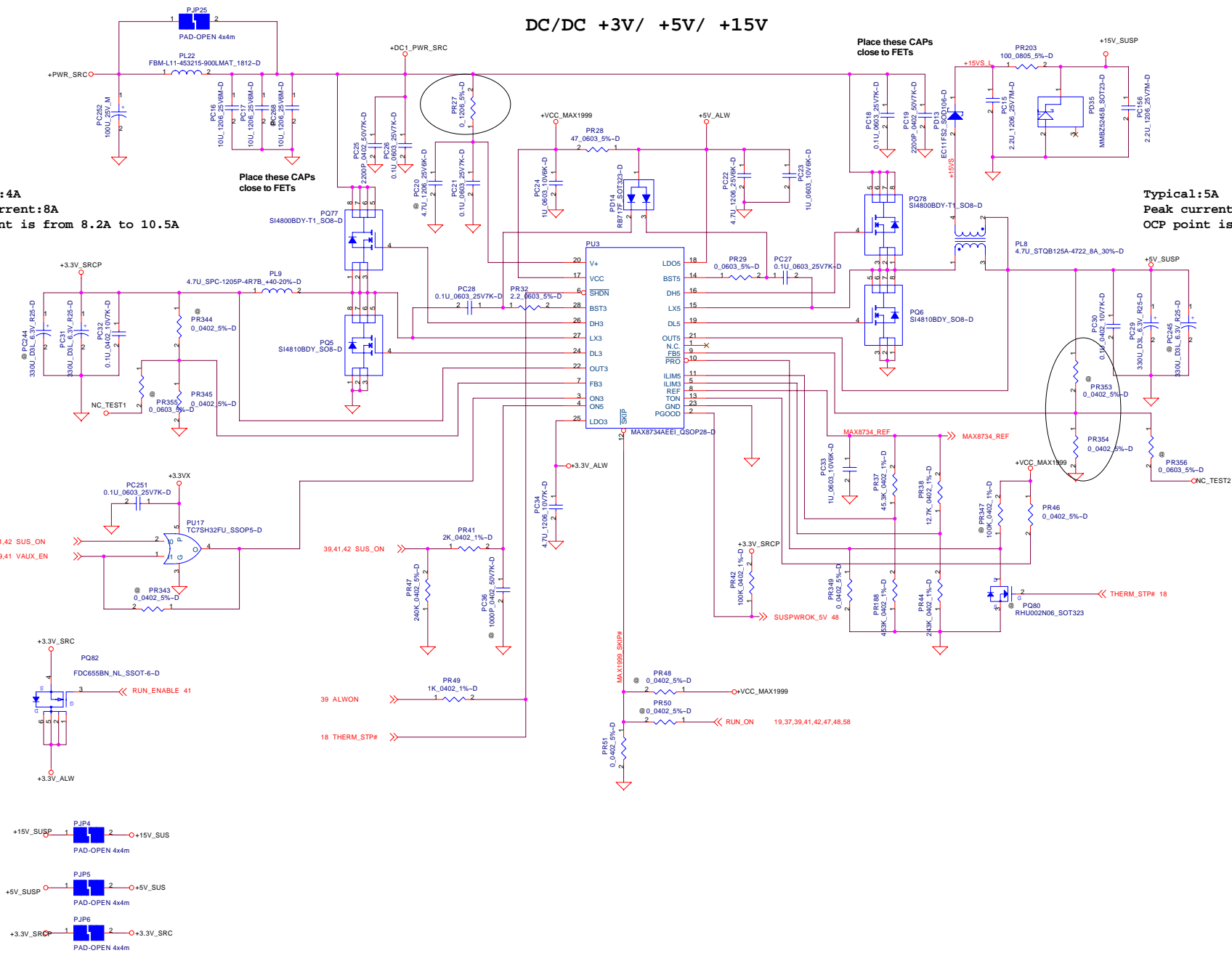

DELL CONFIDENTIAL/PROPRIETARY

Compal Electronics, Inc.

+3.3V/+5V/+15V

LA-2792

Date: Thursday, February 09, 2006 Sheet 46 of 70

THIS SHEET OF ENGINEERING DRAWING IS THE PROPRIETARY PROPERTY OF COMPAL ELECTRONICS, INC. AND CONTAINS CONFIDENTIAL AND TRADE SECRET INFORMATION. THIS SHEET MAY NOT BE TRANSFERRED FROM THE CUSTODY OF THE COMPETENT DIVISION OF R&D DEPARTMENT EXCEPT AS AUTHORIZED BY COMPAL ELECTRONICS, INC. NEITHER THIS SHEET NOR THE INFORMATION IT CONTAINS MAY BE USED BY OR DISCLOSED TO ANY THIRD PARTY WITHOUT PRIOR WRITTEN CONSENT OF COMPAL ELECTRONICS, INC.

+1.5VRUNP / +VCCP_1P05VP

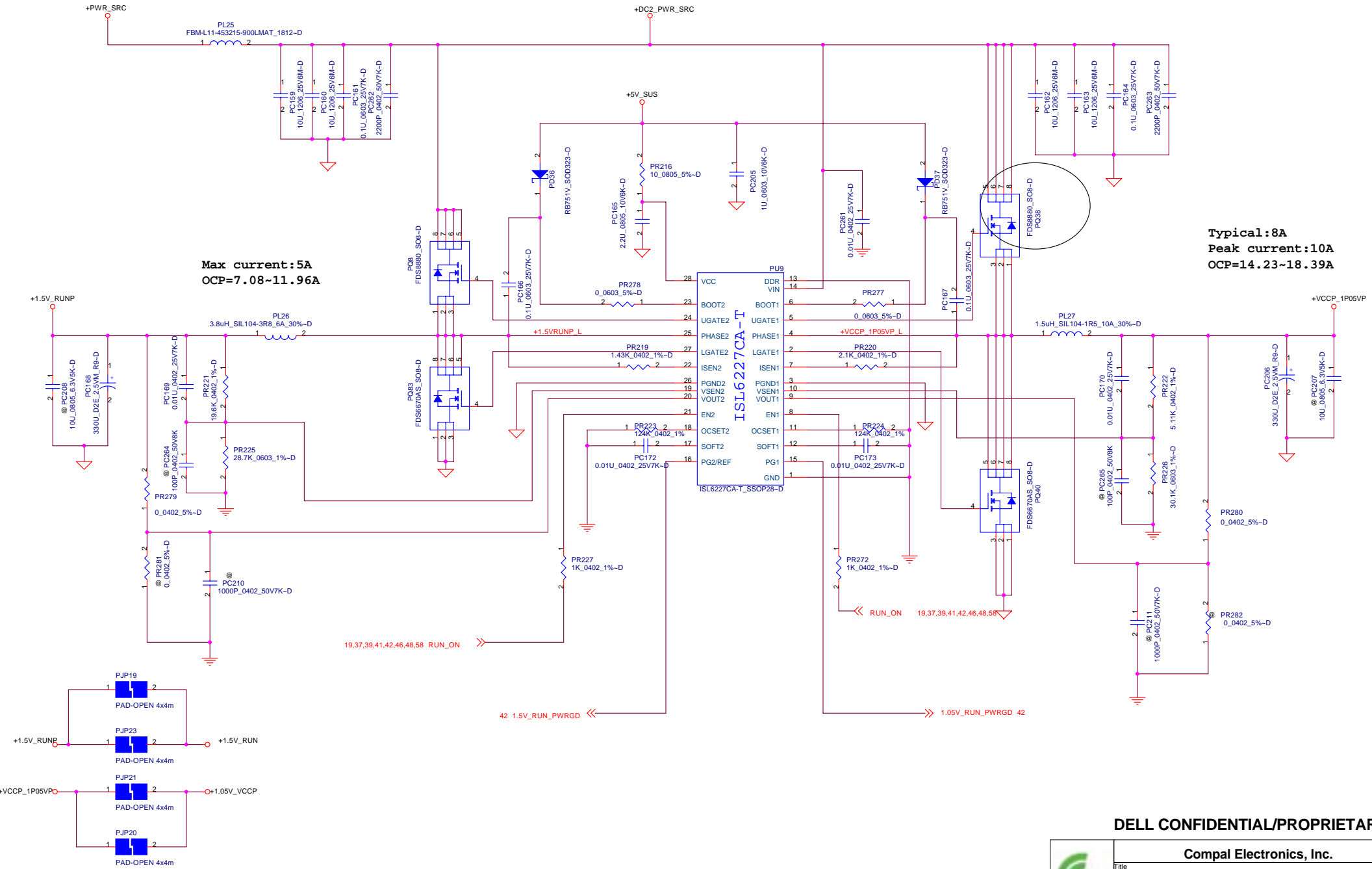

Max current:5A
OCP=7.08~11.96A

Typical:8A
Peak current:10A
OCP=14.23~18.39A

19.37,39.41,42.46,48.58 RUN_ON

42 1.5V_RUN_PWRGD

10.5V_RUN_PWRGD 42

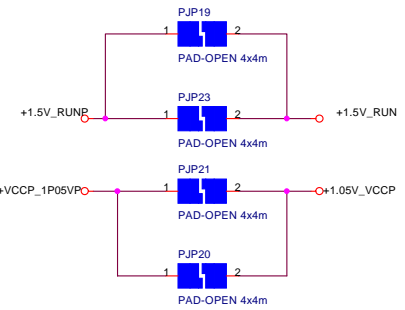

THIS SHEET OF ENGINEERING DRAWING IS THE PROPRIETARY PROPERTY OF COMPAL ELECTRONICS, INC. AND CONTAINS CONFIDENTIAL AND TRADE SECRET INFORMATION. THIS SHEET MAY NOT BE TRANSFERRED FROM THE CUSTODY OF THE COMPETENT DIVISION OF R&D DEPARTMENT EXCEPT AS AUTHORIZED BY COMPAL ELECTRONICS, INC. NEITHER THIS SHEET NOR THE INFORMATION IT CONTAINS MAY BE USED BY OR DISCLOSED TO ANY THIRD PARTY WITHOUT PRIOR WRITTEN CONSENT OF COMPAL ELECTRONICS, INC.

DELL CONFIDENTIAL/PROPRIETARY

Compal Electronics, Inc.			
+1.5VSUSP /+VCCP_1P05VP			
File	Document Number		Rev
	LA-2792		1.0
Date:	Thursday, February 08, 2006	Sheet	47 of 70

+1.8VSUSP/ +0.9V_DDR_VTT

DDR2 Termination

PR193, PD20 are only used with the second-source MAX8632.

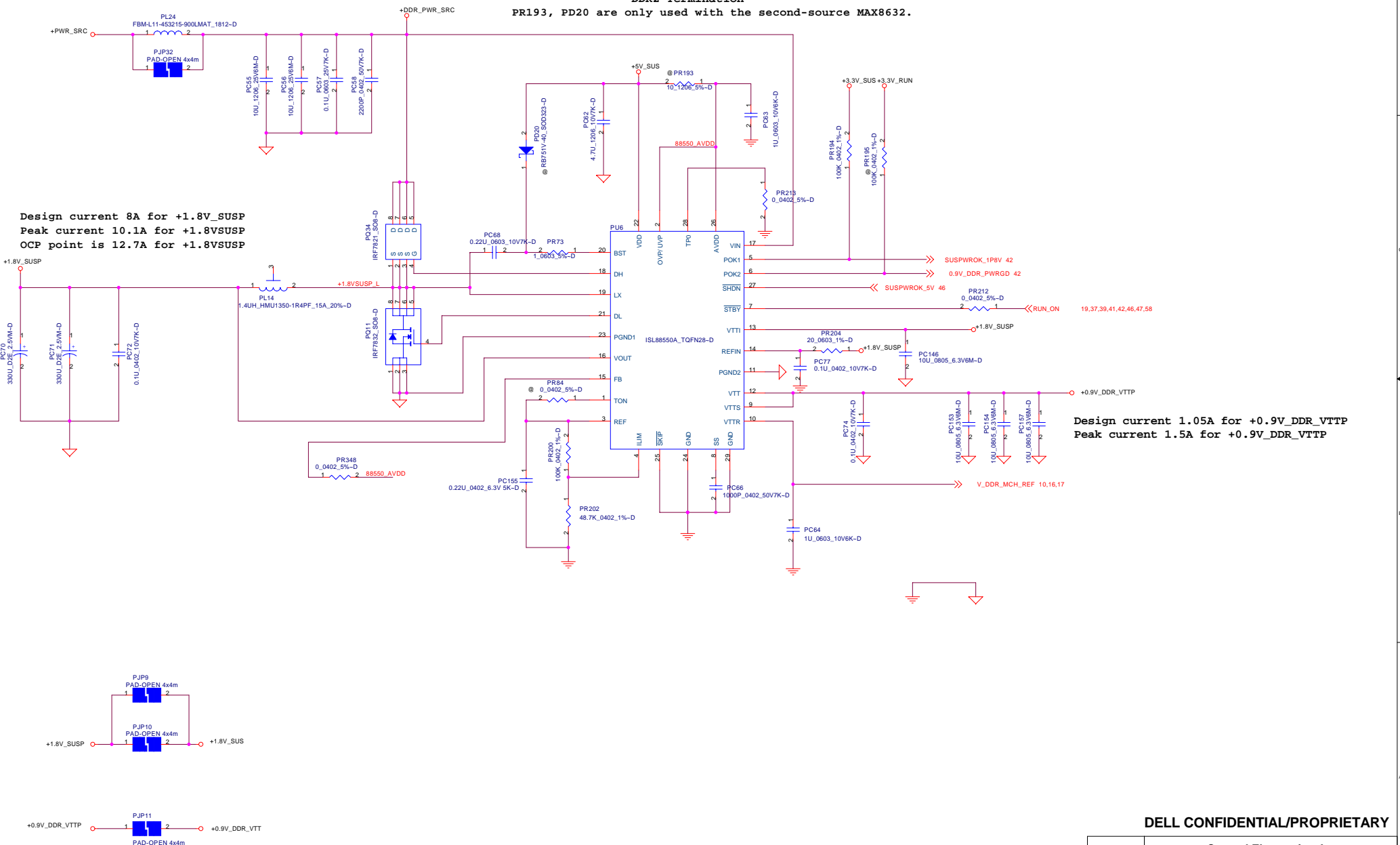

Design current 8A for +1.8V_SUSP
 Peak current 10.1A for +1.8VSUSP
 OCP point is 12.7A for +1.8VSUSP

Design current 1.05A for +0.9V_DDR_VTTP
 Peak current 1.5A for +0.9V_DDR_VTTP

DELL CONFIDENTIAL/PROPRIETARY

Compal Electronics, Inc.	
+1.8VSUSP/ +0.9V_DDR_VT	
Size	Document Number
LA-2792	
Date: Thursday, February 09, 2006	Sheet 48 of 70

PROPRIETARY NOTE: THIS SHEET OF ENGINEERING DRAWING AND SPECIFICATIONS CONTAINS CONFIDENTIAL TRADE SECRET AND OTHER PROPRIETARY INFORMATION OF DELL INC. ("DELL") THIS DOCUMENT MAY NOT BE TRANSFERRED OR COPIED WITHOUT THE EXPRESS WRITTEN AUTHORIZATION OF DELL. IN ADDITION, NEITHER THIS SHEET NOR THE INFORMATION IT CONTAINS MAY BE USED BY OR DISCLOSED TO ANY THIRD PARTY WITHOUT DELL'S EXPRESS WRITTEN CONSENT.

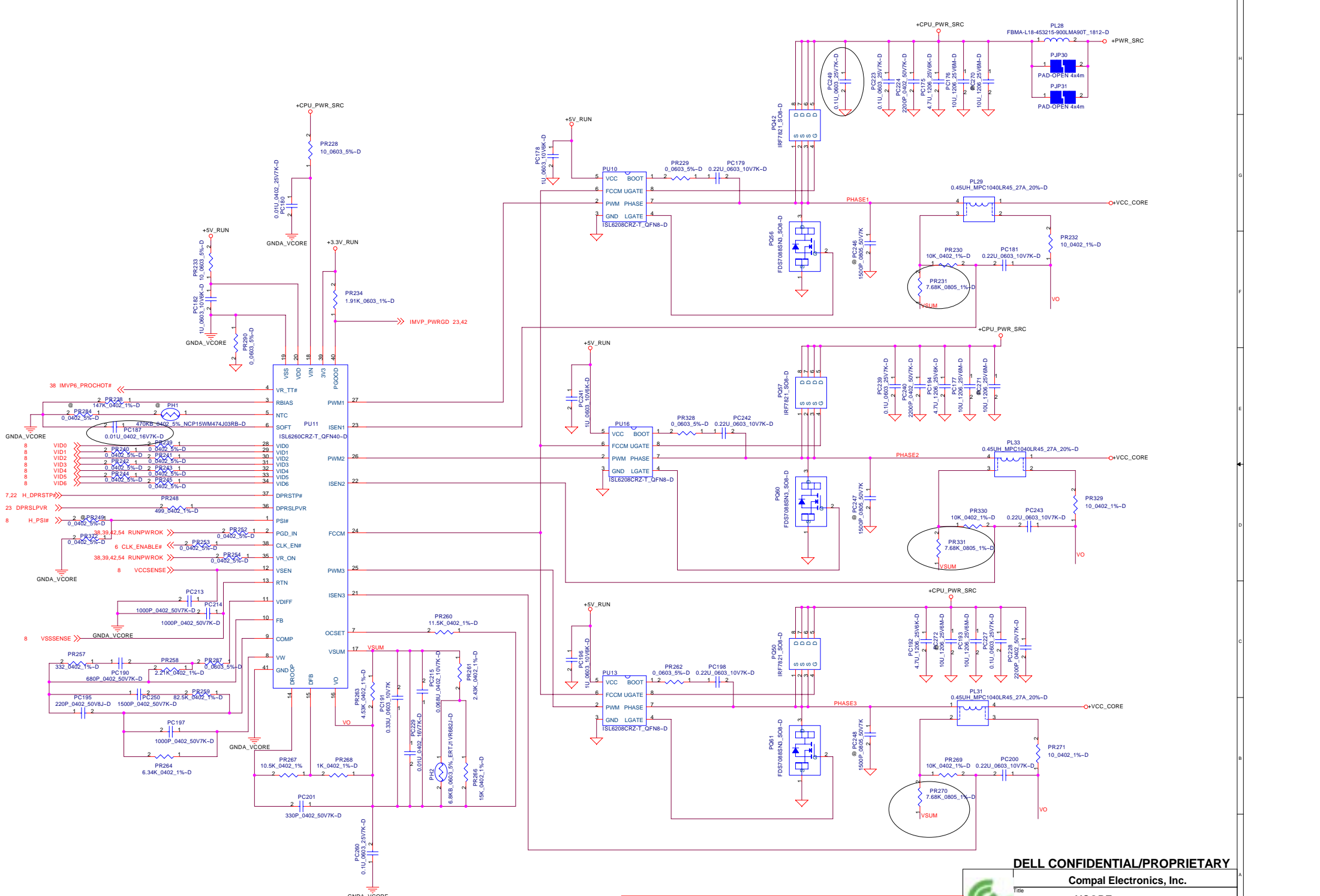

DELL CONFIDENTIAL/PROPRIETARY

Compal Electronics, Inc.

+Vcore

LA-2792

THIS SHEET OF ENGINEERING DRAWING IS THE PROPRIETARY PROPERTY OF COMPAL ELECTRONICS, INC. AND CONTAINS CONFIDENTIAL AND TRADE SECRET INFORMATION. THIS SHEET MAY NOT BE TRANSFERRED FROM THE CUSTODY OF THE COMPETENT DIVISION OF R&D DEPARTMENT EXCEPT AS AUTHORIZED BY COMPAL ELECTRONICS, INC. NEITHER THIS SHEET NOR THE INFORMATION IT CONTAINS MAY BE USED BY OR DISCLOSED TO ANY THIRD PARTY WITHOUT PRIOR WRITTEN CONSENT OF COMPAL ELECTRONICS, INC.

Title		+Vcore	
Size	Document Number	Rev 1.0	
Date: Thursday, February 09, 2006	Sheet 49 of 70		

+DC_IN discharge path

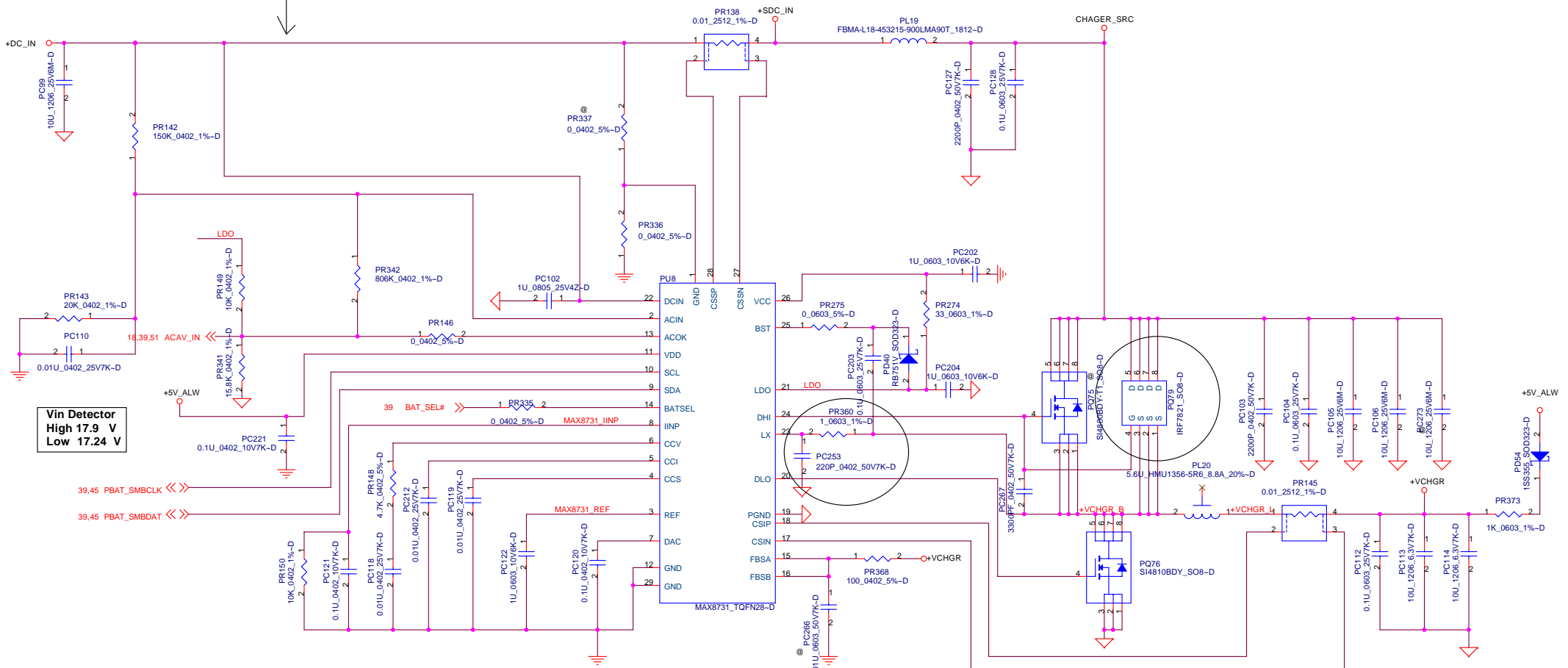

Vin Detector
High 17.9 V
Low 17.24 V

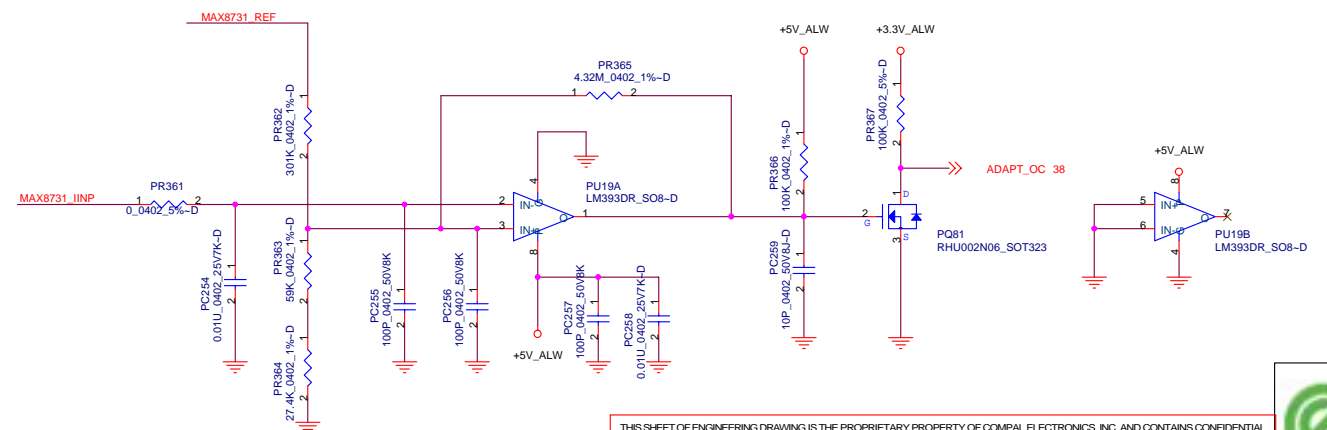

DELL CONFIDENTIAL/PROPRIETARY

THIS SHEET OF ENGINEERING DRAWING IS THE PROPRIETARY PROPERTY OF COMPAL ELECTRONICS, INC. AND CONTAINS CONFIDENTIAL AND TRADE SECRET INFORMATION. THIS SHEET MAY NOT BE TRANSFERRED FROM THE CUSTODY OF THE COMPETENT DIVISION OF R&D DEPARTMENT EXCEPT AS AUTHORIZED BY COMPAL ELECTRONICS, INC. NEITHER THIS SHEET NOR THE INFORMATION IT CONTAINS MAY BE USED BY OR DISCLOSED TO ANY THIRD PARTY WITHOUT PRIOR WRITTEN CONSENT OF COMPAL ELECTRONICS, INC.

			Compal Electronics, Inc.	
			Charger	
File	Document Number			Rev
	LA-2792			1.0
Date:	Thursday, February 09, 2006	Sheet	50	of 70

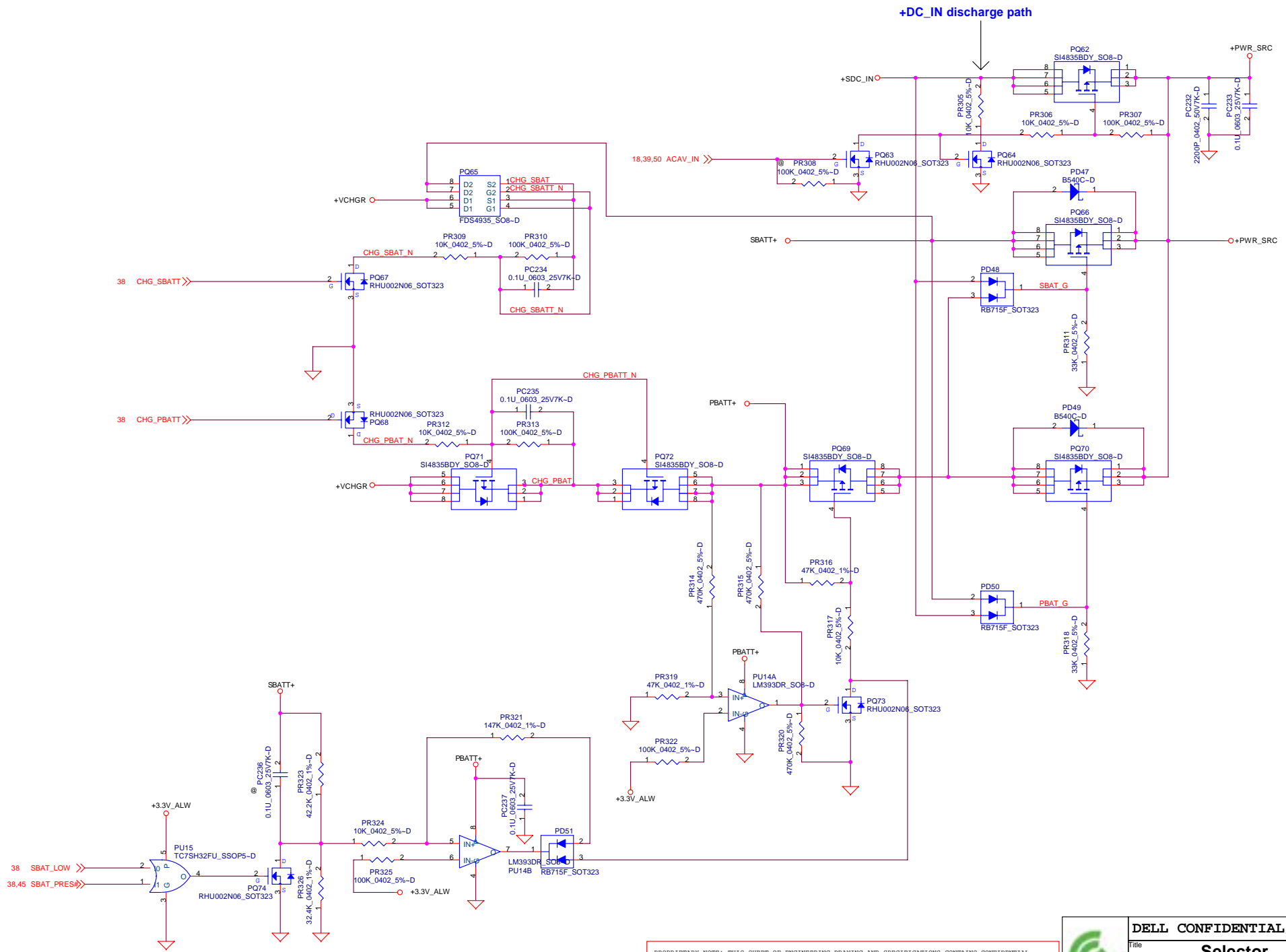

PROPRIETARY NOTE: THIS SHEET OF ENGINEERING DRAWING AND SPECIFICATIONS CONTAINS CONFIDENTIAL TRADE SECRET AND OTHER PROPRIETARY INFORMATION OF DELL INC. ("DELL") THIS DOCUMENT MAY NOT BE TRANSFERRED OR COPIED WITHOUT THE EXPRESS WRITTEN AUTHORIZATION OF DELL. IN ADDITION, NEITHER THIS SHEET NOR THE INFORMATION IT CONTAINS MAY BE USED BY OR DISCLOSED TO ANY THIRD PARTY WITHOUT DELL'S EXPRESS WRITTEN CONSENT.

Selector		
Size	Document Number	Rev
	LA-2792	1.0
Date:	Thursday, February 09, 2006	Sheet 51 of 70

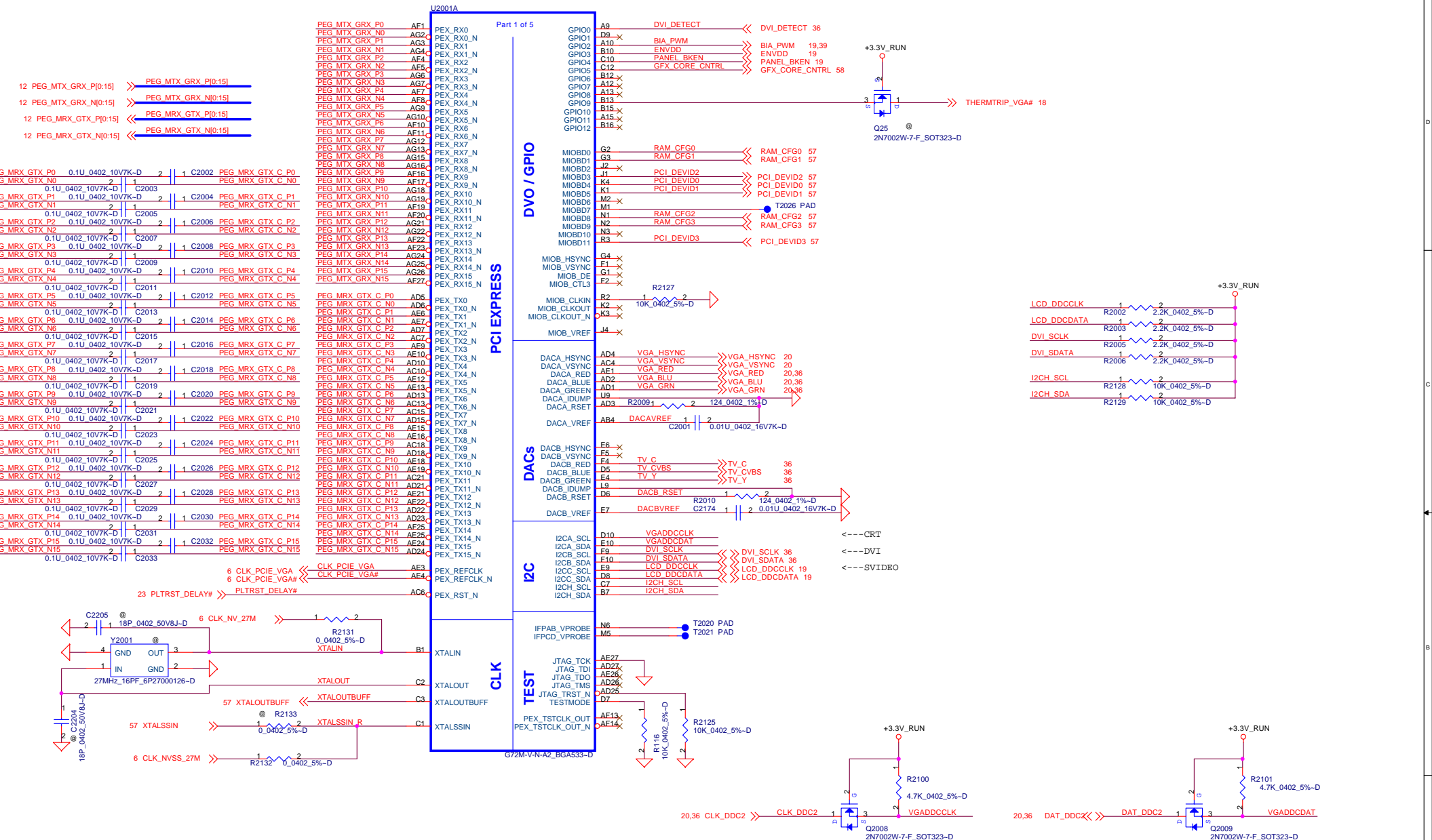

DELL CONFIDENTIAL/PROPRIETARY

Compal Electronics, Inc.			
NVG72M PCIe,GPIO,CLK			
Size	Document Number	Rev	
	LA-2792	1.0	
Date:	Thursday, February 09, 2006	Sheet	52 of 70

PROPRIETARY NOTE: THIS SHEET OF ENGINEERING DRAWING AND SPECIFICATIONS CONTAINS CONFIDENTIAL TRADE SECRET AND OTHER PROPRIETARY INFORMATION OF DELL INC. ("DELL"). THIS DOCUMENT MAY NOT BE TRANSMITTED OR COPIED WITHOUT THE EXPRESS WRITTEN AUTHORIZATION OF DELL. IN ADDITION, NEITHER THIS SHEET NOR THE INFORMATION IT CONTAINS MAY BE USED BY OR DISCLOSED TO ANY THIRD PARTY WITHOUT DELL'S EXPRESS WRITTEN CONSENT.

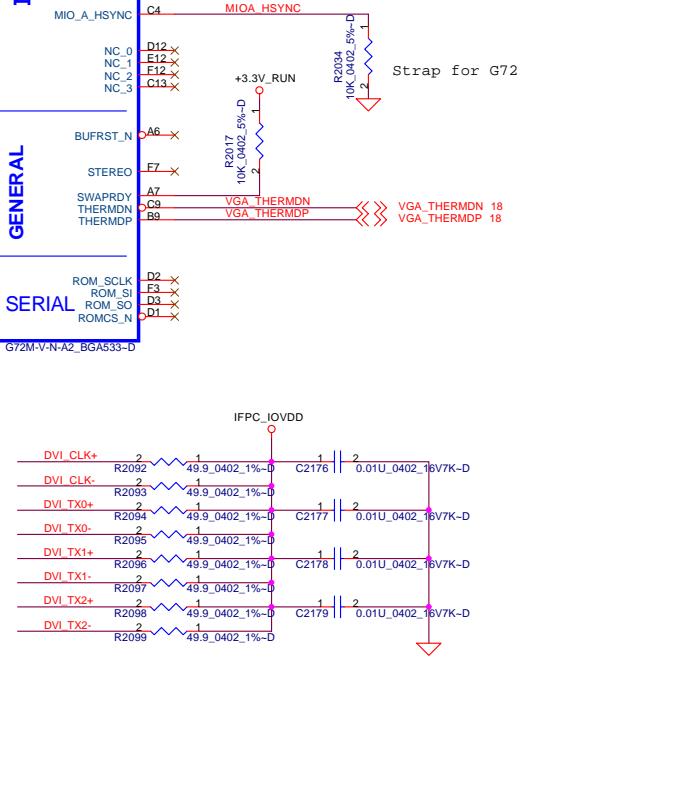
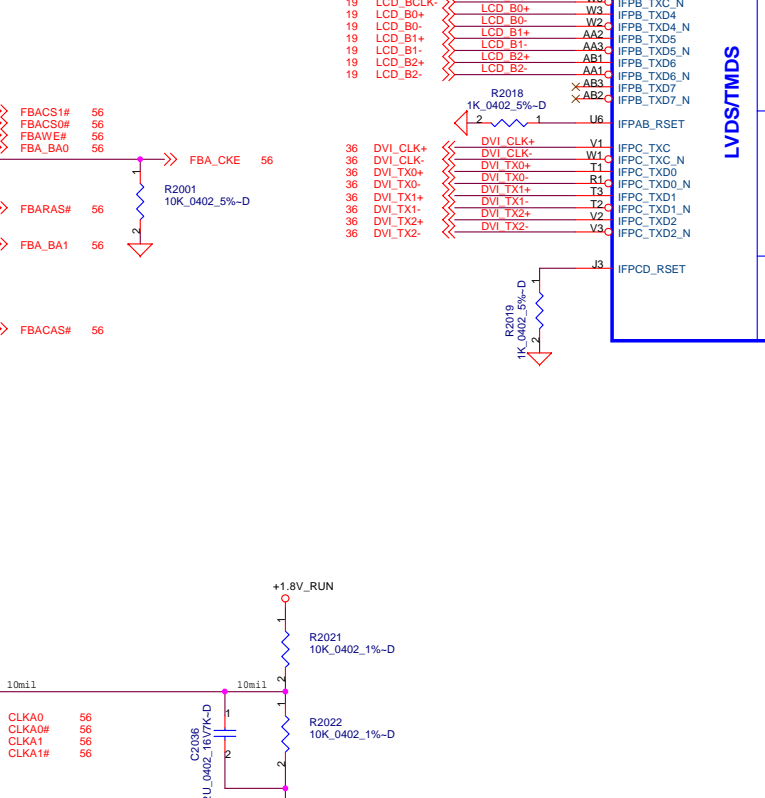
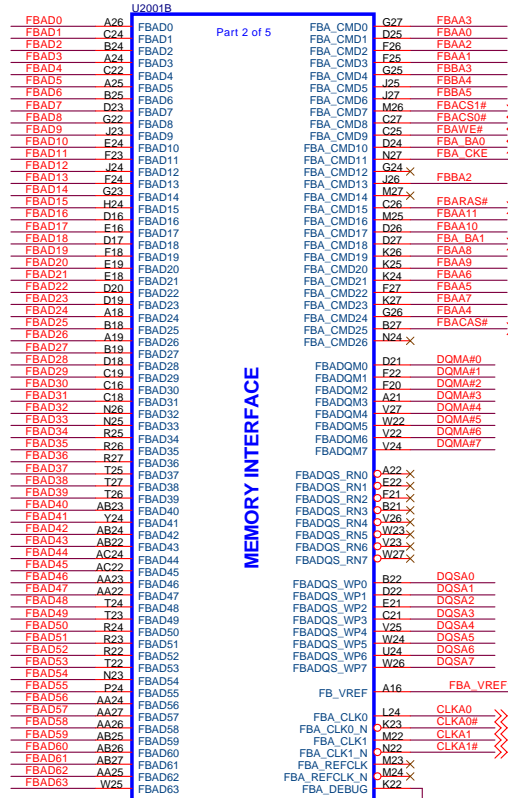
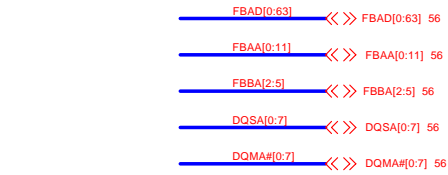

DELL CONFIDENTIAL/PROPRIETARY

Compal Electronics, Inc.
 Title: **NVG72M Memory Interface**
 Size: Document Number
LA-2792
 Date: Thursday, February 09, 2006 Sheet 53 of 70 Rev 1.0

PROPRIETARY NOTE: THIS SHEET OF ENGINEERING DRAWING AND SPECIFICATIONS CONTAINS CONFIDENTIAL TRADE SECRET AND OTHER PROPRIETARY INFORMATION OF DELL INC. ("DELL"). THIS DOCUMENT MAY NOT BE TRANSFERRED OR COPIED WITHOUT THE EXPRESS WRITTEN AUTHORIZATION OF DELL. IN ADDITION, NEITHER THIS SHEET NOR THE INFORMATION IT CONTAINS MAY BE USED BY OR DISCLOSED TO ANY THIRD PARTY WITHOUT DELL'S EXPRESS WRITTEN CONSENT.

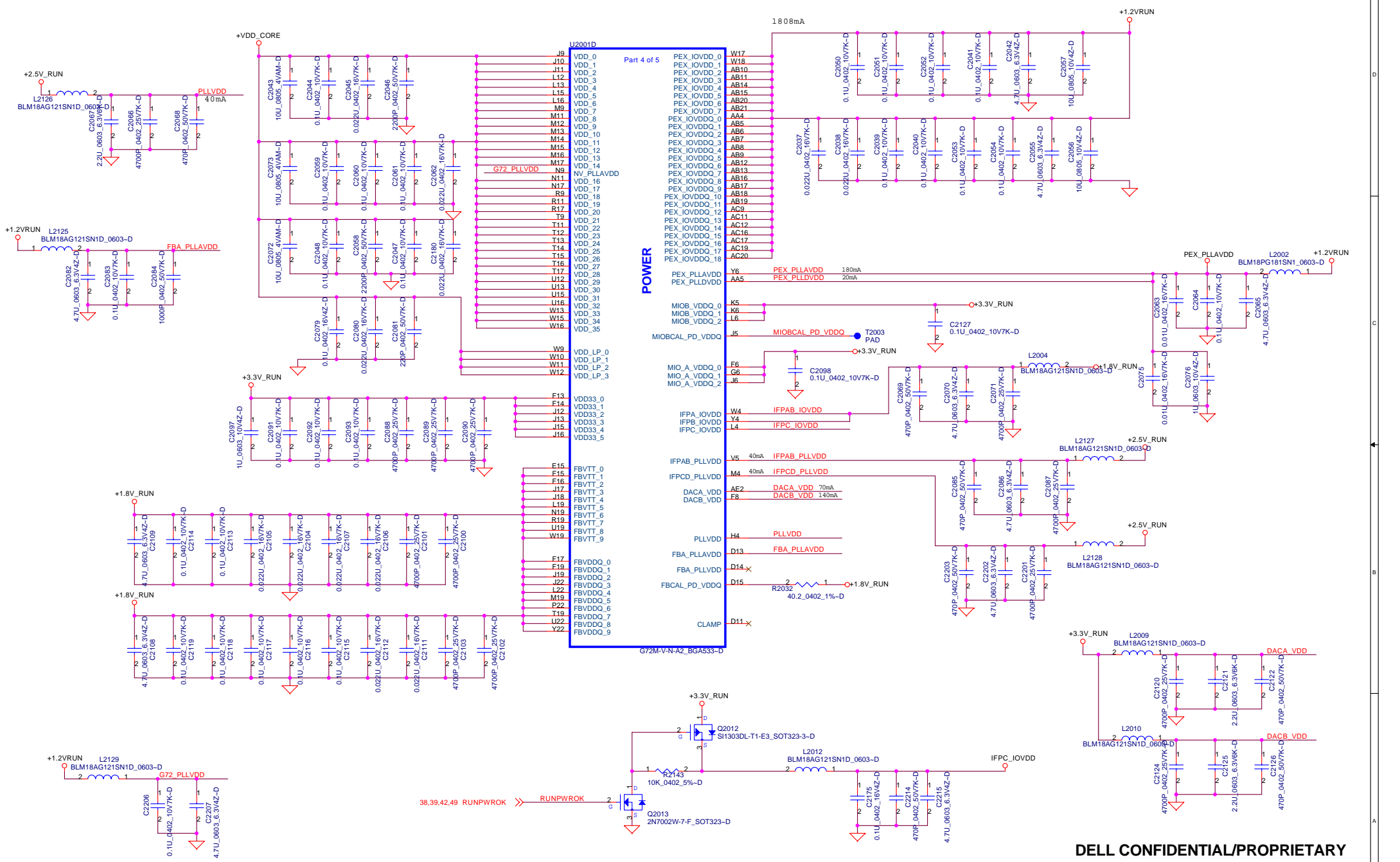

DELL CONFIDENTIAL/PROPRIETARY

Compal Electronics, Inc.			
NVG72M Power			
Size	Document Number	Rev	
	LA-2792	1.0	
Date:	Thursday, February 09, 2006	Sheet	54 of 70

PROPRIETARY NOTE: THIS SHEET OF ENGINEERING DRAWING AND SPECIFICATIONS CONTAINS CONFIDENTIAL TRADE SECRET AND OTHER PROPRIETARY INFORMATION OF DELL INC. ("DELL"). THIS DOCUMENT MAY NOT BE TRANSFERRED OR COPIED WITHOUT THE EXPRESS WRITTEN AUTHORIZATION OF DELL. IN ADDITION, NEITHER THIS SHEET NOR THE INFORMATION IT CONTAINS MAY BE USED BY OR DISCLOSED TO ANY THIRD PARTY WITHOUT DELL'S EXPRESS WRITTEN CONSENT.

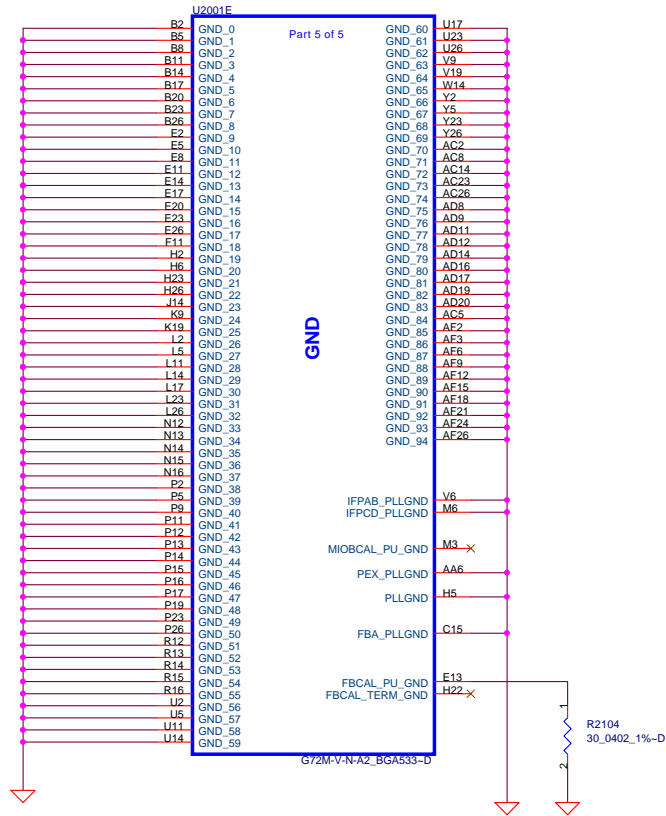

PROPRIETARY NOTE: THIS SHEET OF ENGINEERING DRAWING AND SPECIFICATIONS CONTAINS CONFIDENTIAL TRADE SECRET AND OTHER PROPRIETARY INFORMATION OF DELL INC. ("DELL"). THIS DOCUMENT MAY NOT BE TRANSFERRED OR COPIED WITHOUT THE EXPRESS WRITTEN AUTHORIZATION OF DELL. IN ADDITION, NEITHER THIS SHEET NOR THE INFORMATION IT CONTAINS MAY BE USED BY OR DISCLOSED TO ANY THIRD PARTY WITHOUT DELL'S EXPRESS WRITTEN CONSENT.

DELL CONFIDENTIAL/PROPRIETARY



Compal Electronics, Inc.		
Title NVG72M Ground		
Size	Document Number LA-2792	Rev 1.0
Date	Thursday, February 09, 2006	Sheet 55 of 70

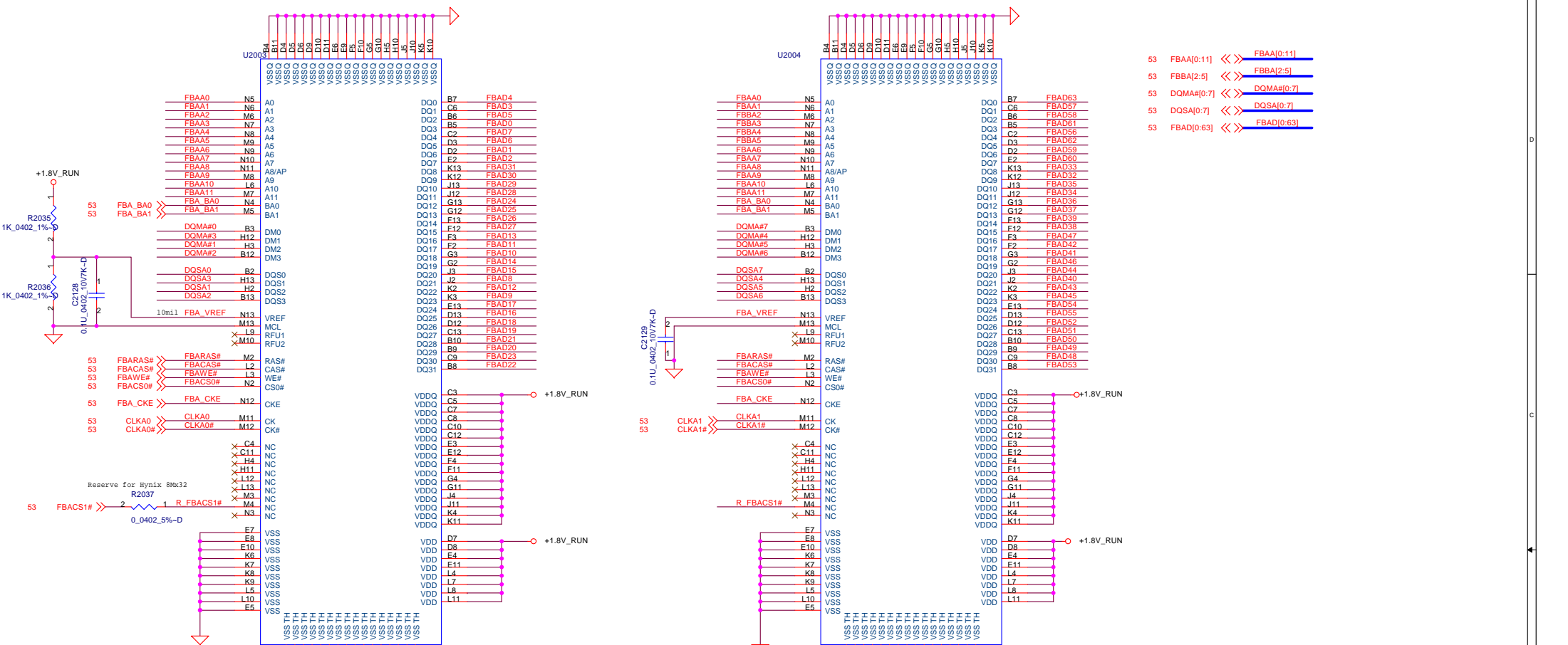

- 53 FBAA[0:1] <<> FBAA[0:1]
- 53 FBBA[2:5] <<> FBBA[2:5]
- 53 DQMA#[0:7] <<> DQMA#[0:7]
- 53 DQSA[0:7] <<> DQSA[0:7]
- 53 FBAD[0:63] <<> FBAD[0:63]

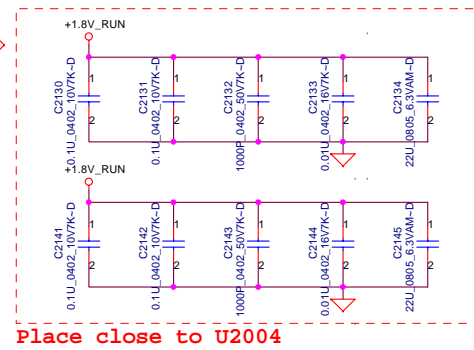
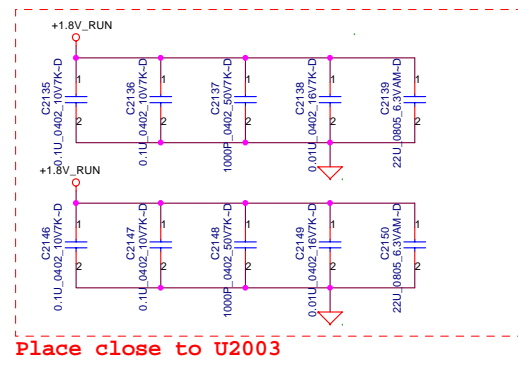
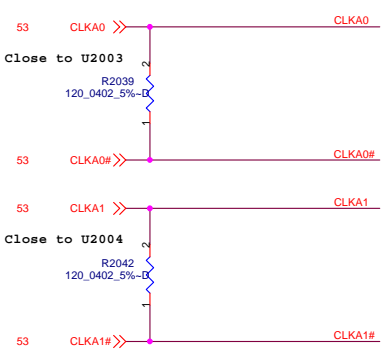
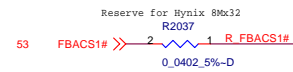

DELL CONFIDENTIAL/PROPRIETARY

				Compal Electronics, Inc.	
				NVG72M External DDR	
Size	Document Number			Rev	1.0
LA-2792					
Date:	Thursday, February 09, 2006	Sheet	56	of	70

PROPRIETARY NOTE: THIS SHEET OF ENGINEERING DRAWING AND SPECIFICATIONS CONTAINS CONFIDENTIAL TRADE SECRET AND OTHER PROPRIETARY INFORMATION OF DELL INC. ("DELL"). THIS DOCUMENT MAY NOT BE TRANSFERRED OR COPIED WITHOUT THE EXPRESS WRITTEN AUTHORIZATION OF DELL. IN ADDITION, NEITHER THIS SHEET NOR THE INFORMATION IT CONTAINS MAY BE USED BY OR DISCLOSED TO ANY THIRD PARTY WITHOUT DELL'S EXPRESS WRITTEN CONSENT.

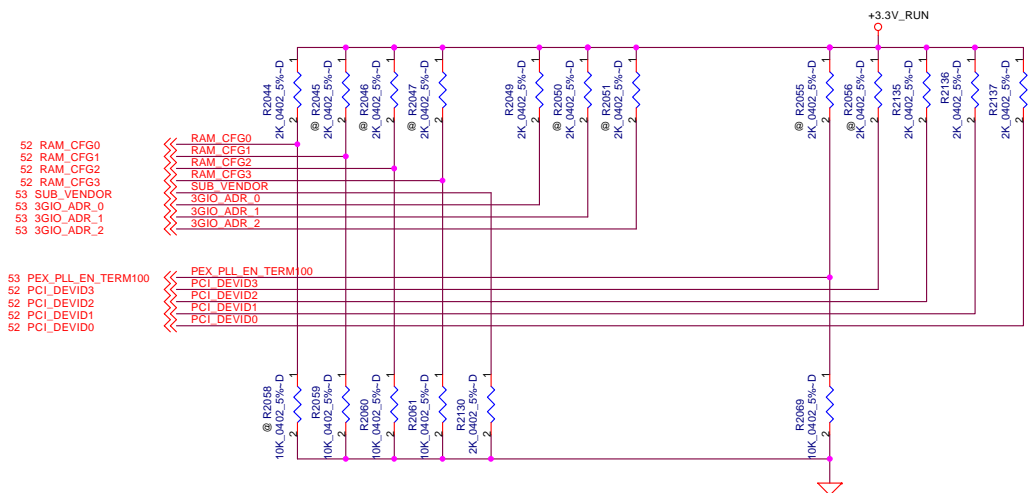

- 52 RAM_CFG0
- 52 RAM_CFG1
- 52 RAM_CFG2
- 52 RAM_CFG3
- 53 SUB_VENDOR
- 53 3GIO_ADR_0
- 53 3GIO_ADR_1
- 53 3GIO_ADR_2

NV44M

STRAPS	PIN	DESCRIPTION	Value
ROM_TYPE[1:0]	MIOBD10 MIOB_VSYNC	Parallel=00, SERIAL AT25F=01 DEFAULT, Serial SST45VF=10, LPC=11	01
SUB_VENDOR	MIOAD1	VBIOS on card (pull high) VBIOS with system BIOS (pull down)	0
PEX_PLL_TERM	MIOAD0		0
RAM_CFG[3:0]	MIOBD0	8Mx32 DDR monolithic (64bit NV44)	0001
	MIOBD1	8Mx32 DDR monolithic (32bit NV44)	1001
	MIOBD8	8Mx32 DDR (Samsung K4D55323QF-GC)	0010
	MIOBD9	4Mx32 DDR generic (64bit NV44)	0100
			4Mx32 DDR generic (32bit NV44)

STRAPS	CONFIG	DESCRIPTION	Value
RAM_CFG[3:0]	8Mx32 DDR	Reserved	0000
		300MHz, 1.8V	0001
		Reserved	0010
	4Mx32 DDR	350MHz, 1.8V	0011
		1.8V I/O	0100
	4Mx32 DDR	Reserved	0101
		2.5V I/O	0110
		Reserved	0111
		Reserved	0111

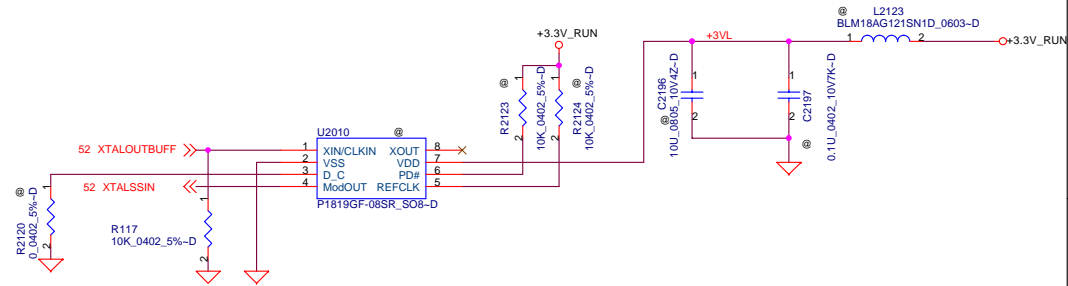

	S0
-1.75% (DOWN)	0
±0.875% (CENTER)	1

S0 Internal pull up

DELL CONFIDENTIAL/PROPRIETARY

Compal Electronics, Inc.

Title: **NVG72M Spread Spectrum & Strapping**

Size: Document Number **LA-2792** Rev: 1.0

Date: Thursday, February 09, 2006 Sheet 57 of 70

PROPRIETARY NOTE: THIS SHEET OF ENGINEERING DRAWING AND SPECIFICATIONS CONTAINS CONFIDENTIAL TRADE SECRET AND OTHER PROPRIETARY INFORMATION OF DELL INC. ("DELL"). THIS DOCUMENT MAY NOT BE TRANSMITTED OR COPIED WITHOUT THE EXPRESS WRITTEN AUTHORIZATION OF DELL. IN ADDITION, NEITHER THIS SHEET NOR THE INFORMATION IT CONTAINS MAY BE USED BY OR DISCLOSED TO ANY THIRD PARTY WITHOUT DELL'S EXPRESS WRITTEN CONSENT.

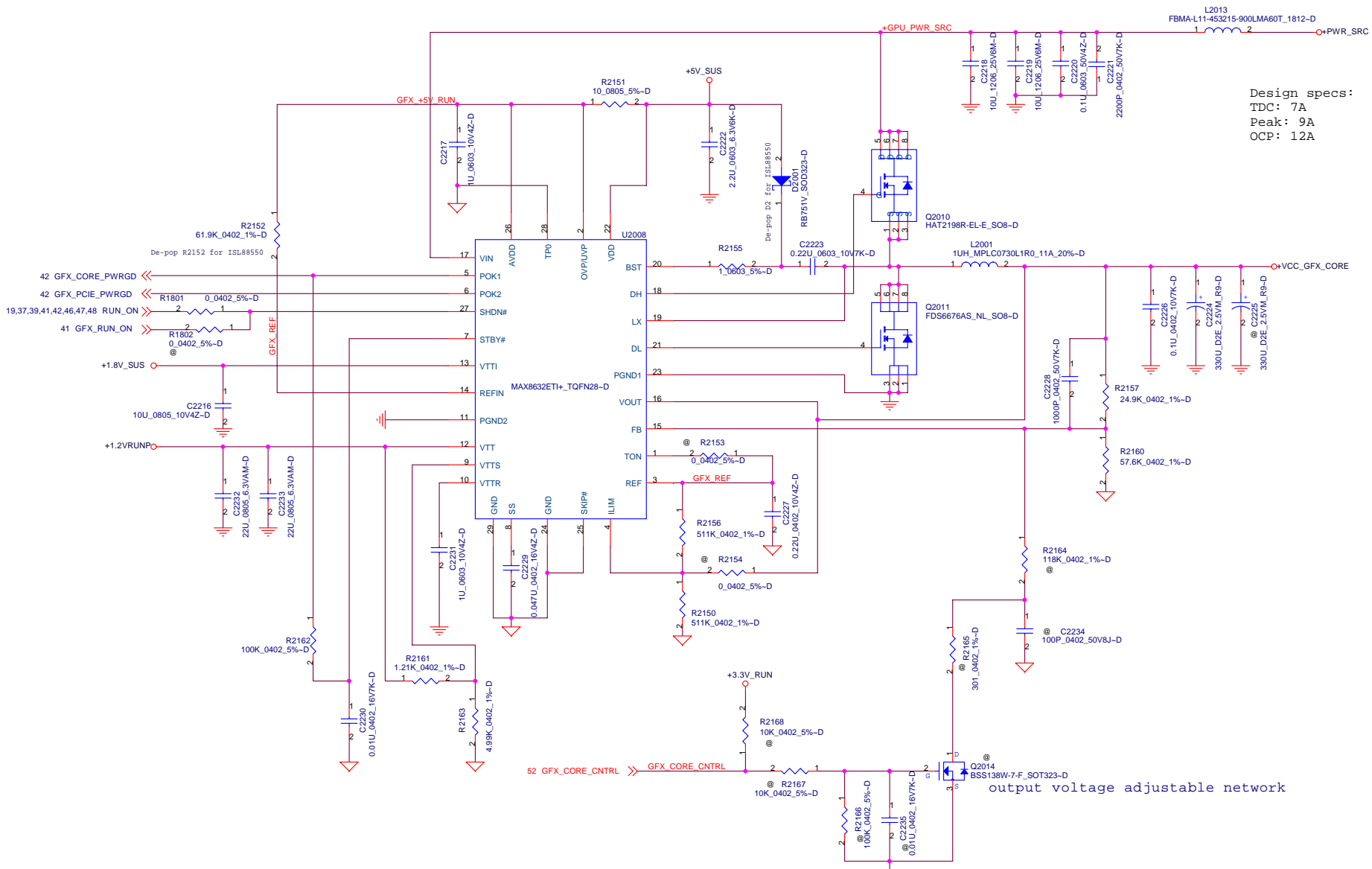

Design specs:
 TDC: 7A
 Peak: 9A
 OCP: 12A

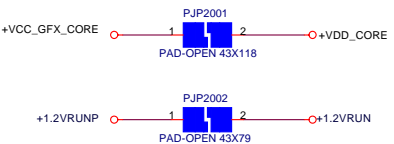

PROPRIETARY NOTE: THIS SHEET OF ENGINEERING DRAWING AND SPECIFICATIONS CONTAINS CONFIDENTIAL TRADE SECRET AND OTHER PROPRIETARY INFORMATION OF DELL INC. ("DELL"). THIS DOCUMENT MAY NOT BE TRANSMITTED OR COPIED WITHOUT THE EXPRESS WRITTEN AUTHORIZATION OF DELL. IN ADDITION, NEITHER THIS SHEET NOR THE INFORMATION IT CONTAINS MAY BE USED BY OR DISCLOSED TO ANY THIRD PARTY WITHOUT DELL'S EXPRESS WRITTEN CONSENT.



DELL CONFIDENTIAL/PROPRIETARY

Compal Electronics, Inc.

Title: **NVG72M VDD_CORE**

Size: Document Number

Date: Thursday, February 09, 2006 Sheet 58 of 70

Rev: **LA-2792** 1.0

Version Change List (P. I. R. List)

Item	Page#	Title	Date	Request Owner	Issue Description	Solution Description	Rev.
1	31	H/W	05/27	Roger	Smart card pin definition not match the cage pin define	Change JSC pin connection, pin1 connect to GND, pin2 connect to SC_DET# ~ pin10 connect to +SC_PWR	0.2
2	52	H/W	05/27	Roger	TV out no out put	Add R1790, R1791, R1792 for 75 ohms	0.2
3	40	H/W	05/27	Roger	Remove power switch to save placement spacing	Remove SW1. Reseve R1793 pad for power switch	0.2
4	20	H/W	05/27	Roger	Docking CRT HSYNC, VSYNC connect to the out put side of buffer	DOCK_HSYNC connect from U190 pin4 to docking connector pin 209, DOCK_VSYNC connect from U191 pin4 to docking connector pin 210	0.2
5	32	H/W	05/27	Roger	Improve RJ45 center tap driving	Connect +2.5VLAN to JIO pin 14 for RJ45 center tap	0.2
6	39	H/W	05/27	Roger	SPI ROM pass trough mode connect error	Change FDATAIN to ICHO_FDATAIN and connect from U216 pin 106 to U213 pin5. Chagne FDATAOUT to ICHI_FDATAOUT and connect from U216 pin 108 to R1788 pin1	0.2
7	39	H/W	05/27	Roger	Flash Recovery strapping issue	Change R474, R475 from 100K to 10K	0.2
8	ALL	H/W	05/30	Brike	To fix MEC5004 VCC1 power lading	Change net from +3VALW to +3VSRC	0.2
9	43	H/W	05/30	Brike	None	Delete H21 and change H4 footprint from H_C176D122to H_C176D102	0.2
10	58	H/W	05/30	Brike	To meet VGA core power rating	Change footprint to JUMP_43X118	0.2
11	39	H/W	06/01	Will	For delay MEC5004 internal 1.8V reg.	Modified C1769 from 4.7UF to 22UF.	0.2
12	23	H/W	06/01	Will	To improve rise time of serial DO from SPI ROM.	Modified R389 from 10K to 1K..	0.2
13	41	H/W	06/01	Will	None	Add pullup R2149 to HDDC_EN# and R2148 MODC_EN#.	0.2
14	39	H/W	06/01	Will	None	Change power on SPI ROM (pins 3 and 8) from +3VALW to +3VSUS	0.2
15	58	H/W	06/01	Brike	None	U2008 pin 16 change pull-up panle to +3VRUN	0.2
16	13	H/W	06/01	Lester	Intel Checklist recommends a 1 nH ferrite which calculates to 200 ohm.	L34 value change to BLM18PG181SN1_0603~D	0.2
17	06	H/W	06/01	Lester	Add resistor for cystal drive current limiting	Add R32 0 ohm resistor	0.2
18	39	H/W	06/01	Will	Correct SPI connection for SMSC recommand	ICH7M.P5 connect to MEC 5004.107, MEC5004.108 connect to SPI ROM.5. ICH7M.P2 connect to MEC 5004.105, MEC5004.106 connect to SPI ROM.2	0.2
19	38	H/W	06/02	Roger	SMSC recommand add VBUS_DET pull up resistor	Add R1440 100K for LAN_TPM_EN# (VBUS_DET)	0.2
20	33	H/W	06/02	Roger	Add MDC disable circuit	Add R1441, R1442, R1443, Q64. ECE5018 pin 67 program MDC_RST_DIS#	0.2
21	34	H/W	06/06	Roger	None	Change U8 NNCD6.8RL-A to D5 NNCD5.6LG	0.2
23	3	H/W	06/06	Roger	None	Fixed USB table	0.2
24	27	H/W	06/14	Roger	U10 (STAC9200) pin21 (GPIO0) is analog power plane	Change R156 pull up from +3VSUS to +VDDA	0.3

PROPRIETARY NOTE: THIS SHEET OF ENGINEERING DRAWING AND SPECIFICATIONS CONTAINS CONFIDENTIAL TRADE SECRET AND OTHER PROPRIETARY INFORMATION OF DELL INC. ("DELL") THIS DOCUMENT MAY NOT BE TRANSFERRED OR COPIED WITHOUT THE EXPRESS WRITTEN AUTHORIZATION OF DELL. IN ADDITION, NEITHER THIS SHEET NOR THE INFORMATION IT CONTAINS MAY BE USED BY OR DISCLOSED TO ANY THIRD PARTY WITHOUT DELL'S EXPRESS WRITTEN CONSENT.

DELL CONFIDENTIAL/PROPRIETARY		
Changed-List History 1		
Size	Document Number	Rev
	LA-2792	1.0
Date:	Thursday, February 09, 2006	Sheet 59 of 70

Version Change List (P. I. R. List)

Item	Page#	Title	Date	Request Owner	Issue Description	Solution Description	Rev.
25	7	H/W	06/14	Roger	Change ITP debug to XDP debug definition for Yonah CPU	Change R387, R417, R391, R436, R416, R415 to 56 ohms. Add R33 56 ohms. Change R424 to 1K ohms.	0.3
26	39	H/W	06/14	Roger	For easier flash EC code	Add short pad and change R475 to 1K ohms	0.3
27	40	H/W	06/14	Roger	For easier power switch	Change R1793 to a pad like CMOS pad	0.3
28	34	H/W	06/14	Roger	ME change mini card stand off to Latch	Remove H22,H23,H24,H25. Add JCLIP1,JCLIP2	0.3
29	42	H/W	06/14	Roger	EMI request add caps for the splite power plane that PCI bus routed	Add C1806,C1807,C1808,C1809,C1810,C1811	0.3
30	41	H/W	06/16	Roger	Reserve discharg circuit for +5VRUN,+3VRUN,+1.8VRUN,+1.5VRUN,+0.9V_DDR_VTT,+2.5VRUN power rails	Add R1793,R1794,R1795,R1796,R1797,R1798,Q87,Q88,Q89,Q90,Q91,Q92	0.3
31	58	H/W	06/20	Roger	Replace ISL6269 and MAX1510 circuits with MAX8632 solution	Remove ISL6269 and MAX1510 circuit. Add MAX8632 circuit	0.3
32	28	H/W	06/21	Gautam	Reserve ST M45PE20 for LOM EEPROM	Add U3 (ST M45PE20) co-layout with U188 (AT45BCM021B)	0.3
33	42	H/W	06/23	Gary	EMI request add caps for the splite power plane that PCI bus routed	Add C1812-C184 0.047uF_0402. Change C1810, C1811 from 0603 to 0402 package	0.3
34	38	H/W	06/23	Roger	+3VRUN leakage at AC mode in S5	Change R1362 pull up from +3VSRC to +3VRUN	0.3
35	All	H/W	06/24	Roger	Follow Dell USB assignment recommendation	Update USB table, block diagram and connection	0.3
36	39	H/W	06/24	Will	4.7uF cap for VR_Cap pin of REV B 5504	Change C1769 for 22uF 0805 size to 4.7uF 0603 size	0.3
37	All	H/W	06/24	Will	Change +3V/+5V design to follow Dell recommendation	Change +3VSRC to +3VALW except for LOM	0.3
38	28	H/W	06/24	Gautam	IEEE testing the voltage level are closer to the higher end of IEEE range	Change R1364 from 1.15K to 1.18K_0402_1%	0.3
39	7	H/W	06/24	Lester	Required by Intel for B0 Yonah.	Add R1378 (51_0603_1%) for TEST2 pulldown	0.3
40	39	H/W	06/24	Lester	Required by Intel for B0 Yonah.	Populate R1752 and add note "No stuff when doing flash recovery"	0.3
41	58	H/W	06/27	Joey	Change Gfx VDD_CORE controller power source	Change +5VSUS to +5VRUN. Change +3VSUS to +3VRUN. Depop C2225	0.3
42	33	H/W	06/28	Rossana	MDC signal by pass caps not require	Delete C93, C82, C73	0.3
43	31,40	H/W	06/28	Rossana	Reseved USB port of OZ77C6 for Biometrics reader	Change JTPAD from 10 pins to 20 pins. Add USB_BIO+/- on U1 pin18,19 connect to JPAD pin9,11	0.3
44	30	H/W	06/28	Rossana	Gerber Gate List issue	Remove C1783, C1784	0.3
45	34	H/W	06/28	Rossana	Gerber Gate List issue	Remove L18, R149, and R144 - direct connect USB to Wireless LAN card	0.3
46	34	H/W	06/28	Rossana	Gerber Gate List issue	Add R1603 connect to JMINI2 pin46, outgoing signal BT_ACTIVE	0.3
47	34	H/W	06/28	Rossana	Gerber Gate List issue	Add series 0-ohms R1609, R1610 for pins 3 and 5 of JMINI2	0.3

PROPRIETARY NOTE: THIS SHEET OF ENGINEERING DRAWING AND SPECIFICATIONS CONTAINS CONFIDENTIAL TRADE SECRET AND OTHER PROPRIETARY INFORMATION OF DELL INC. ("DELL") THIS DOCUMENT MAY NOT BE TRANSFERRED OR COPIED WITHOUT THE EXPRESS WRITTEN AUTHORIZATION OF DELL. IN ADDITION, NEITHER THIS SHEET NOR THE INFORMATION IT CONTAINS MAY BE USED BY OR DISCLOSED TO ANY THIRD PARTY WITHOUT DELL'S EXPRESS WRITTEN CONSENT.

			DELL CONFIDENTIAL/PROPRIETARY		
Title Changed-List History 2					
Size	Document Number				Rev
	LA-2792				1.0
Date:	Thursday, February 09, 2006		Sheet	60	of 70

Version Change List (P. I. R. List)

Item	Page#	Title	Date	Request Owner	Issue Description	Solution Description	Rev.
48	34	H/W	06/28	Rossana	Gerber Gate List issue	Change C159 and C1785 from 10uF to 0.1uF	0.3
49	34	H/W	06/28	Rossana	Gerber Gate List issue	Add T1 test point for JMINI1 pin 42	0.3
50	36	H/W	06/28	Rossana	Gerber Gate List issue	Add C1817~1820 for U180,U178,U179,U177	0.3
51	39	H/W	06/28	Rossana	Gerber Gate List issue	Change R30 pull up from +3VSRC to +3VALW	0.3
52	43	H/W	06/28	Rossana	Change sniffer switch type, the active direction swap	WIRELESS_ON/OFF# connection from pin1 to pin 4 of JSNIFF, pin3 connect to GND, pin2 NC, pin 1 connect to SNIFFER#	0.3
53	36	H/W	06/28	Rossana	Gerber Gate List issue	Add C1821 1000pF for +DOCK_PWR_SRC, add C1827 1000pF for DOCK_DC_IN	0.3
54	35	H/W	06/28	Rossana	Gerber Gate List issue	Add C1822 0.1uF_0402 and C1823,C1824 .47uF_0402 for QBUF power	0.3
55	26,27	H/W	06/29	Rossana	Gerber Gate List issue	Follow Dell "Travis_Audio_0628" reference circuit design	0.3
56	39	H/W	06/29	Will	Gerber Gate List issue	Change L4 form MURATA BLM11A121S to BLM18PG181SN1	0.3
57	24	H/W	06/30	Will	Gerber Gate List issue	Remove C375, C37 for ICH_V5REF_RUN, remove C420 for ICH_V5REF_SUS	0.3
58	24	H/W	06/30	Will	Gerber Gate List issue	Add R37 0.5 ohm 0603 resistor connect to L42 pin1	0.3
59	24	H/W	06/30	Scott	Gerber Gate List issue	Populate C347 and C442	0.3
60	24	H/W	06/30	Scott	Gerber Gate List issue	Change C450 for 220uF to 330uF poly cap	0.3
61	40	H/W	06/30	Roger	Match Dell JTPAD pinout definition	Match Dell JTPAD pinout definition, add C62, C63 for BIO power rail bypass	0.3
62	26,27	H/W	06/30	Rossana	Gerber Gate List issue	R162 change from 8.2K to 2.2K, remove D33, D34, Change C1800, C1801 from 1uF to 2.2uF, change C534 from 0.1uF to 1uF, del C533.	0.3
63	26	H/W	06/30	Rossana	Gerber Gate List issue	HP_NB_SENSE move from GPIO2 to GPIO0 of U10, add series resistor 0 ohm for this signal	0.3
64	7	H/W	07/07	Roger	Support A1 Yanah CPU	De-pop R513, R514 for A1 yanah CPU	0.3
65	56	H/W	07/25	Roger	Set VRAM VREF to 50% of VDDQ	Change R2035, R2036 to 1K_0402_1%	0.4
66	54	H/W	07/25	Roger	Nvidia G72 design change	De-pop L2008, C2094, C2095, C2096 for FBA_PLLVDD	0.4
67	54	H/W	07/25	Roger	Nvidia G72 design change	Remove C2110 and NC for CLAMP (D11)	0.4
68	54	H/W	07/25	Roger	Nvidia G72 power design change	Remove L2003, L2006, L2007, L2124, L2008, C2094, C2095, C2096	0.4
69	54	H/W	07/25	Roger	Nvidia G72 power design change	Pop L2129, C2206, C2207 for G72_PLLVDD	0.4
70	7	H/W	08/01	Roger	Gerber Gate List issue item 6	Change Change R417 to 150 ohm, R415 to 51 ohm, R387 to 39.2 ohm, R436 to 27.4 ohm, R391 to 680 ohm, R424 to 22.6 ohm	0.4
71	38	H/W	08/01	Roger	Gerber Gate List issue item 8	Change R110 from 68 ohm to 75 ohm for H_PROCHOT# pull up	0.4
72	43	H/W	08/01	Roger	Gerber Gate List issue item 9	Change the voltage rail on sniffer LED pull-ups (at Q13 and Q16) from +3VALW to +3VSUS	0.4

PROPRIETARY NOTE: THIS SHEET OF ENGINEERING DRAWING AND SPECIFICATIONS CONTAINS CONFIDENTIAL TRADE SECRET AND OTHER PROPRIETARY INFORMATION OF DELL INC. ("DELL") THIS DOCUMENT MAY NOT BE TRANSFERRED OR COPIED WITHOUT THE EXPRESS WRITTEN AUTHORIZATION OF DELL. IN ADDITION, NEITHER THIS SHEET NOR THE INFORMATION IT CONTAINS MAY BE USED BY OR DISCLOSED TO ANY THIRD PARTY WITHOUT DELL'S EXPRESS WRITTEN CONSENT.

DELL CONFIDENTIAL/PROPRIETARY			
Changed-List History 2			
Size	Document Number		Rev
	LA-2792		1.0
Date:	Thursday, February 09, 2006		Sheet 61 of 70

Version Change List (P. I. R. List)

Item	Page#	Title	Date	Request Owner	Issue Description	Solution Description	Rev.
73	7	H/W	08/01	Roger	None	Remove unnecessary capacitor C1805	0.4
74	18	H/W	08/01	Roger	Gerber Gate List issue item 12	Remove Q84, C1804. Connect U15 pin1 to VGA_THERMDP, U15 pin2 to VGA_THERMDN	0.4
75	40	H/W	08/01	Roger	Hall switch design on touch pad moudle	Depop U46 and C54	0.4
76	18	H/W	08/01	Roger	Gerber Gate List issue item 13	Add a thermistor circuit to VCP input (pin 3) for the SODIMM temp sensor. Add Q15, R476, R477, R478, C66	0.4
77	57	H/W	08/01	Roger	Gerber Gate List issue item 15	Remove Gxf thermal sensor U2007 (ADM1032), C2181, C2182	0.4
78	38	H/W	08/01	Roger	Gerber Gate List issue item 19	Move NB_MUTE from U215 pin 107 to pin73	0.4
79	16,17	H/W	08/01	Roger	Gerber Gate List issue item 20,21	Remove R178, pop R177	0.4
80	10,23	H/W	08/01	Roger	Gerber Gate List issue item 22,23	Depop R253, populate R1799	0.4
81	38	H/W	08/01	Roger	Change board ID for X01	Depop R419 and populate R405	0.4
82	42	H/W	08/02	Roger	Gerber Gate List issue item3	Connect 2.5V_RUN_PWRGD net to LDO_POK pin. Add depop R49	0.4
83	18	H/W	08/02	Roger	Gerber Gate List issue item11	Add R1800 31.6K ohm resistor for Vmargin circuit.	0.4
84	23	H/W	08/02	Roger	Gerber Gate List issue item5	Change R389 from 1K to 10K	0.4
85	33, 40	H/W	08/04	Steven	Combine the BT and TP in 30 PIN connector.	Delete JBT and move components to JTAP.	0.4
86	42	H/W	08/04	Steven	Gerber Gate List issue item3	Add Depop resister R2169, R2170, R2171.	0.4
87	22, 23	H/W	08/04	Steven	For intel NAPA platform check list 1.5 request.	Chnage R425 from 330hm pull-down to 8.2KOhm pull-up. And add pull-up resister R227 in SIO_RCIN#.	0.4
88	16	H/W	08/09	Roger	V_DDR_MCH_REF discharge issue	Add R51 (100K_0402) connect to V_DDR_MCH_REF	0.4
89	23	H/W	08/09	Roger	Leakage issue when system into S3	Change SIO_EXT_SMI#, SIO_EXT_SCI# pull up to +3VSUS	0.4
90	36	H/W	08/09	Roger	Refer Dell docking reference circuit	Remove R1320, R1319	0.4
91	12	H/W	08/09	Roger	Gerber Gate List issue item 28	Depop R357	0.4
92	38	H/W	08/09	Roger	Follow Dell EC GPIO assignment	Move SPDIF_SHDN from pin31 to pin76, remove R1601, R1602, net SYSOPT0	0.4
93	28	H/W	08/10	Roger	Gerber Gate List issue item 30	Add R53 4.7K resistor for LOM_SO pull down	0.4
94	28	H/W	08/10	Roger	Gerber Gate List issue item 33	Connect BCM5752 pin C4 to ECE5018 pin75 net name LOM_CABLE_DETECT. Series no stuff resistor R55	0.4
95	24	H/W	08/10	Roger	Gerber Gate List issue item 37	Connect BCM5752 pin C4 to ECE5018 pin75 net name LOM_CABLE_DETECT. Series no stuff resistor R55	0.4
96	38	H/W	08/10	Roger	Gerber Gate List issue item 39	R1171 change pull up from +3VRUN to +3VSUS	0.4
97	38	H/W	08/10	Roger	Gerber Gate List issue item 42	Add a 4.7uF cap for ECE5018 VDDA33 coupling	0.4

PROPRIETARY NOTE: THIS SHEET OF ENGINEERING DRAWING AND SPECIFICATIONS CONTAINS CONFIDENTIAL TRADE SECRET AND OTHER PROPRIETARY INFORMATION OF DELL INC. ("DELL") THIS DOCUMENT MAY NOT BE TRANSFERRED OR COPIED WITHOUT THE EXPRESS WRITTEN AUTHORIZATION OF DELL. IN ADDITION, NEITHER THIS SHEET NOR THE INFORMATION IT CONTAINS MAY BE USED BY OR DISCLOSED TO ANY THIRD PARTY WITHOUT DELL'S EXPRESS WRITTEN CONSENT.

DELL CONFIDENTIAL/PROPRIETARY			
Changed-List History 2			
Size	Document Number		Rev
	LA-2792		1.0
Date:	Thursday, February 09, 2006		Sheet 62 of 70

Version Change List (P. I. R. List)

Item	Page#	Title	Date	Request Owner	Issue Description	Solution Description	Rev.
98	39	H/W	08/10	Roger	Gerber Gate List issue item 43	Add a 0 Ohm 0402 resistor R62 in series with the RTC_CELL and EMC5004 pin 121	0.4
99	7	H/W	08/10	Roger	Follow Intel CRB circuit	R513, R514 pull up to +VCCP	0.4
100	39	H/W	08/10	Roger	Gerber Gate List issue item 46	Add resistor R63 (0_0402_5%) between the BIA_PWM signal and MEC5004 pin 73	0.4
101	39	H/W	08/10	Roger	Gerber Gate List issue item 47	Change ITP_DBRESET# connection from EMC5004 pin 55 to pin96	0.4
102	22	H/W	08/10	Roger	Gerber Gate List issue item 50	Add no stuff C69 (0.1U_0402_16V4Z) between THRMTRIP_ICH# and GND	0.4
103	41	H/W	08/10	Roger	None	Change R1795 pin 1 connect from +1.8VRUN to +1.8VSUS for discharge	0.4
104	23	H/W	08/10	Roger	Gerber Gate List issue item 51	Move pull-up R388 to pin 1 side of R1787	0.4
105	6	H/W	08/10	Roger	Gerber Gate List issue item 29	Add C70 (0.1U_0402_16V4Z) for +CK_VDD_MAIN decoupling. Remove R291, R343, R329 to save spacing	0.4
106	7	H/W	08/11	Roger	Gerber Gate List issue item 68	Remove R513 and R514 platform no longer use Yonah A00	0.4
107	42	H/W	08/11	Roger	Gerber Gate List issue item 65	Populate 0ohm for R49, R313, R319, R334	0.4
108	41	H/W	08/11	Roger	Gerber Gate List issue item 67	Change R494 to 20K	0.4
109	7	H/W	08/11	Roger	Gerber Gate List issue item 69	Add no stuff C71 and C72 for +VCCP of JITP	0.4
110	7	H/W	08/11	Roger	Gerber Gate List issue item 70	Change R416 and R33 from 56 ohm to 54.9 ohm	0.4
111	12	H/W	08/11	Roger	Gerber Gate List issue item 72	Delete R333 to follow reference schematics	0.4
112	28	H/W	08/11	Roger	Gerber Gate List issue item 34	Add R68 (20K_0402_5%) and R70 (39K_0402_1%) for LAN_LOW_PWR voltage divider connect to pin K5	0.4
113	26,27,38	H/W	08/12	Roger	Gerber Gate List issue item 75	DOCK_HP_MUTE# for GPIO2 of codec connect to ECE5018 pin 81. EAPD for GPIO3 of codec connect to additional Q11 gate	0.4
114	38	H/W	08/15	Roger	Gerber Gate List issue item 38	Chnge SYS_PME# pull up from +3VRUN to +3VALW. Add no stuff R71 in series	0.4
115	38	H/W	08/15	Roger	Gerber Gate List issue item 41	Remove HP_NB_SENSE from ECE5018 pin 106 to pin 82	0.4
106	23	H/W	08/15	Roger	Gerber Gate List issue item 188,189	Depop R428,Change value of R75 to 10k ohms	0.4
107	6	H/W	08/15	Roger	Nvidia 27MHz clock has to be 1.2V max	Add R73 150 ohms for CLK_NV_27M voltage divider	0.4
108	52	H/W	08/15	Roger	Gerber Gate List issue item 211	Add R74 0 ohms in series to PLTRST_DELAY#	0.4
109	40	H/W	08/16	Roger	Gerber Gate List issue item 48	Change R1750 and R1751 to L1 and L2	0.4
110	40	H/W	08/16	Roger	Gerber Gate List issue item 48	Change R1750 and R1751 to L1 and L2	0.4
111	39	H/W	08/16	Roger	Gerber Gate List issue item 217	Remove R166. Move R1635 for AFT_INT# move to page 39	0.4
112	39	H/W	08/16	Roger	Add pull up for open drain out put	Add R93 pull up to +3VALW for BAT_SEL#	0.4

PROPRIETARY NOTE: THIS SHEET OF ENGINEERING DRAWING AND SPECIFICATIONS CONTAINS CONFIDENTIAL TRADE SECRET AND OTHER PROPRIETARY INFORMATION OF DELL INC. ("DELL") THIS DOCUMENT MAY NOT BE TRANSFERRED OR COPIED WITHOUT THE EXPRESS WRITTEN AUTHORIZATION OF DELL. IN ADDITION, NEITHER THIS SHEET NOR THE INFORMATION IT CONTAINS MAY BE USED BY OR DISCLOSED TO ANY THIRD PARTY WITHOUT DELL'S EXPRESS WRITTEN CONSENT.

DELL CONFIDENTIAL/PROPRIETARY			
Changed-List History 2			
Size	Document Number		Rev
	LA-2792		1.0
Date:	Thursday, February 09, 2006		Sheet 63 of 70

Version Change List (P. I. R. List)

Item	Page#	Title	Date	Request Owner	Issue Description	Solution Description	Rev.
113	38	H/W	08/16	Roger	Mute internal speaker when docking audio jack plug in	Add pull down resistor for DOCK_HP_MUTE#	0.4
114	58	H/W	09/07	Roger	G72MV VDDCORE fixed to 1.0 V	Depop R2164,R2165,R2166,R2167,R2168,Q2014,C2235. Change R2160 from 69.8K ohms to 57.6K ohms	0.4
115	06	H/W	09/07	Roger	Follow Dell CoE schematics	Change C329, C333 from 33pF to 27pF	0.5
116	43	H/W	09/14	Roger	Blue tooth LED too bright	Change R8 from 3.3K to 1K ohms	0.5
117	41	H/W	09/14	Roger	+1.8VSUS discharge low issue	Populate Q89, R1795	0.5
118	39	H/W	09/14	Roger	LID_CL# can't assert low	Change R482 from 100K to 1M ohms	0.5
119	39	H/W	09/14	Roger	R470 from 10K to 100K is for save the pull up current.	R470 from 10K to 100K	0.5
120	34, 39	H/W	10/13	Steven	Connect 8051TX to WWAN Pin 19 and Connect 8051RX to WWAN Pin 42.	Modified.	0.5
121	22	H/W	10/15	Steven	Gerber Gate List issue item 60. Per M07 ICH reference schematics rev A05.	Add R12 0-ohm tuning resistor between R36 pin2 and X1 pin1	0.5
122	41	H/W	10/17	Steven	Gerber Gate List issue item 66	Change R1795 to a 30 ohm 0603 resistor	0.5
123	52	H/W	10/17	Steven	Gerber Gate List issue item 67. Use 27MHz clock from CK410.	Pop R2131, R2132, and depop Y2001, C2204, C2205, and R2133	0.5
124	19	H/W	10/17	Steven	Gerber Gate List issue item 65. Make sure BIA_PWM logic high level is at +3.3V.	Add R92 pullup to +3VRUN on BIA_PWM	0.5
125	39	H/W	10/18	Steven	MEC5004 per SMSC recommendations to add circuit for improving POR issue.	Add de-pop components R23, R25, R97, R102, R104, Q20, Q19, C22, D2002. And change C1769 to 22u.	0.5
126	38	H/W	10/18	Steven	change board ID to X02	Pop R95, R419 and De-pop R108, R405.	0.5
127	23	H/W	10/18	Steven	Gerber Gate List issue item 78. Pull up LAMP_STAT# to +3VRUN	Change R75 pull-up to +3.3V_RUN.	0.5
128	40	H/W	10/18	Steven	Gerber Gate List issue item 77. add 10pF cap between GND and pin2 of L1/L2.	Add capacitor C23, C35.	0.5
129	6	H/W	10/19	Steven	Gerber Gate List issue item 72. Inductor design follow M07 design on L40,L32 (Size:0805).	Change L32, L40 from 0603 to 0805.	0.5
130	23	H/W	10/19	Steven	Gerber Gate List issue item 79. SATA_DET# is pull up to +3.3V_SUS.	Change R784 pull up to +3.3V_SUS.	0.5
131	9	H/W	10/20	Steven	Gerber Gate List issue item 84	Change the 32 high frequency decoupling caps, 0805 X5R, from 22uF to 10uF. Depop C354 and C618.Change C352, C496, C497, and C365 from 330uF/7mOhm to 330uF/6mOhm SP caps.	0.5
132	34	H/W	10/20	Steven	Gerber Gate List issue item 82	Connect PLTRST# instead of PLTRST_DELAY# to WLAN and WWAN connectors.	0.5
128	23	H/W	10/20	Steven	IMVP_PWRGD glitch issue	Add C82 0.1uF cap on IMVP_PWRGD to filter the glitch	0.5
129	28	H/W	10/21	Steven	Q68 surge current	Add R120 (0603) and C80 0.1uF cap Q68 pin1 for reduce surge current	0.5
130	40,43	H/W	10/21	Steven	BT & HDD LED is on when the SNIFFER is turned on.	Added a circuit (FET and Resistors) to keep the BT LED & HDD LED off when the SNIFFER is turned on	0.5

PROPRIETARY NOTE: THIS SHEET OF ENGINEERING DRAWING AND SPECIFICATIONS CONTAINS CONFIDENTIAL TRADE SECRET AND OTHER PROPRIETARY INFORMATION OF DELL INC. ("DELL") THIS DOCUMENT MAY NOT BE TRANSFERRED OR COPIED WITHOUT THE EXPRESS WRITTEN AUTHORIZATION OF DELL. IN ADDITION, NEITHER THIS SHEET NOR THE INFORMATION IT CONTAINS MAY BE USED BY OR DISCLOSED TO ANY THIRD PARTY WITHOUT DELL'S EXPRESS WRITTEN CONSENT.

			DELL CONFIDENTIAL/PROPRIETARY		
Title Changed-List History 2					
Size	Document Number				Rev
	LA-2792				1.0
Date:	Thursday, February 09, 2006		Sheet	64	of 70

Version Change List (P. I. R. List)

Item	Page#	Title	Date	Request Owner	Issue Description	Solution Description	Rev.
131	38	H/W	10/21	Steven	Gerber Gate List issue item 81	Depop R1440	0.5
132	34	H/W	10/22	Steven	Add Intel WoWLAN Support Circuit	Add pop components Q21 and R101, and un-pop componet R24.	0.5
133	18	H/W	10/24	Steven	Gerber Gate List issue item 89. Change OTP trip temperature to 88 deg C.	Change R249 to 332K and R262 to 118K.	0.5
134	39	H/W	10/24	Steven	Gerber Gate List issue item 90. Pop SMSC workround circuit for 11/7 build.	Pop R23, R25, R97, R102, R104, Q20, Q19, C22, D2002.	0.5
135	39	H/W	10/24	Steven	Gerber Gate List issue item 91. Add a 0 ohm pulldown resistor on TEST_PIN.	Add R110 0ohm resister.	0.5
136	52	H/W	10/24	Steven	Gerber Gate List issue item 94. Connect GPIO9 of G72 to THERMTRIP3# of EMC4000.	Add 0 Ohm resister R112 and connect to EMC4000.	0.5
137	58	H/W	10/24	Steven	Gerber Gate List issue item 95.	Change R2155 from 0 to 1 Ohm.	0.5
138	58	H/W	10/24	Steven	Gerber Gate List issue item 96.	Change +5V_RUN to +5V_SUS at VDD.	0.5
139	58	H/W	10/24	Steven	Gerber Gate List issue item 97.	Change +3.3V_RUN to +3.3V_SUS at R2158.	0.5
140	58	H/W	10/24	Steven	Gerber Gate List issue item 98.	Change +1.8V_RUN to +1.8V_SUS at pin 13.	0.5
141	52	H/W	10/24	Steven	Gerber Gate List issue item 113. Add a 10K pull-down to TESTMODE pin on G72.	Add 10K Ohm resister R116.	0.5
142	43	H/W	10/24	Steven	Gerber Gate List issue item 111. Remove one of the pull-ups on SNIFFER_LED_OFF#.	Remove Pull up resister R1447.	0.5
143	43	H/W	10/24	Steven	Gerber Gate List issue item 111.	More R76 to pin 1 of Q66 and populate	0.5
144	34	H/W	10/24	Steven	Add Intel WoWLAN Support Circuit	Replace Q21 and R101 to D2003.	0.5
145	20	H/W	10/24	Steven	Gerber Gate List issue item 109. Add 39 ohm resistors at output of U190 and U191.	Add resister R101 and R114.	0.5
146	18	H/W	10/24	Steven	Gerber Gate List issue item 93. Add thermistor circuit to VCP2 (pin 40) of EMC4000. Please route to 5V_CAL_SIO2# (pin 80, GPIO B4 on ECE5018).	Add thermistor circuit R479, R480, R481, C36, Q21.	0.5
147	54	H/W	10/24	Steven	Gerber Gate List issue item 106. Change FBCAL_PD_VDDQ terminating resistor.	Change R2032 from 37.4 to 40.2 ohms.	0.5
148	54	H/W	10/24	Steven	Gerber Gate List issue item 105. Change FBCAL_PU_GND terminating resistor.	Change R2104 from 37.4 to 30 ohms.	0.5
149	43	H/W	10/24	Steven	Gerber Gate List issue item 114. Modified the circuit and Add and D2004. Chnage Q1 to 3904, R1149/1448 change to 10K and 1K.	Modified the circuit and Add and D2004. Chnage Q1 to 3904, R1149/1448 change to 10K and 1K.	0.5
150	58	H/W	10/25	Steven	Gerber Gate List issue item 120. Pull up R2159 to +3.3V_SUS.	Change R2159 to pull up +3V_SUS.	0.5
151	40	H/W	10/25	Steven	Gerber Gate List issue item 119. For fix the IMVP_PWRGOOD glitch issue.	Change delay circuit R1764 from 200KOhm, C1788 to 470PF to +1.8V_run and +3V_run.	0.5
152	43	H/W	10/25	Steven	Gerber Gate List issue item 104. Modified the SATA_ACT# circuit.	Modified the circuit Pull up R1449 to +5V_SUS and R1445 to +5V_run. R2 move to Q1 pin 3, SNIFFER_LED change to GPIO82.	0.5
153	34	H/W	10/25	Steven	Gerber Gate List issue item 115. Change LTRST_DELAY# to PLTRST# on WLAN.	Chnage PLTRST_DELAY# to PLTRST# on the WLAN connector.	0.5
154	58	H/W	10/25	Steven	Gerber Gate List issue item 117. Modified Vcore voltage switching circuit.	Change R2168 to +3.3V_SUS.	0.5

PROPRIETARY NOTE: THIS SHEET OF ENGINEERING DRAWING AND SPECIFICATIONS CONTAINS CONFIDENTIAL TRADE SECRET AND OTHER PROPRIETARY INFORMATION OF DELL INC. ("DELL") THIS DOCUMENT MAY NOT BE TRANSFERRED OR COPIED WITHOUT THE EXPRESS WRITTEN AUTHORIZATION OF DELL. IN ADDITION, NEITHER THIS SHEET NOR THE INFORMATION IT CONTAINS MAY BE USED BY OR DISCLOSED TO ANY THIRD PARTY WITHOUT DELL'S EXPRESS WRITTEN CONSENT.

DELL CONFIDENTIAL/PROPRIETARY			
Chaged-List History 2			
Size	Document Number		Rev
	LA-2792		1.0
Date:	Thursday, February 09, 2006	Sheet	65 of 70

Version Change List (P. I. R. List)

Item	Page#	Title	Date	Request Owner	Issue Description	Solution Description	Rev.
155	57	H/W	10/25	Steven	Gerber Gate List issue item 118. Depop the discrete spread spectrum circuit.	Depop R2120, U2010, R2123, R2124, C2196, C2197 and L2123. Add R117 10K pull down resistor.	0.5
156	20	H/W	10/25	Steven	Gerber Gate List issue item 116. Add diode HSYNC and VSYNC buffers.	Add D2005 (RB751) in U190, U191 Pin 5.	0.5
157	18	H/W	10/25	Steven	For improving Gerber Gate List issue item 94 leakage issue.	Change 00hm resistor to Q25.	0.5
158	58	H/W	10/25	Steven	Cancelled Gerber Gate List issue item 97.	Change +3.3V_SUS to +3.3V_RUN at R2159.	0.5
159	40, 43	H/W	10/26	Steven	Modified HDD/BT disable circuit.	Move 40 BT Disable circuit to 43.	0.5
160	58	H/W	10/26	Steven	Gerber Gate List issue item 121. Delete resistors R2158 and R2159 on sheet 58.	Remove R2158 and R2159.	0.5
161	41	H/W	10/29	Steven	For improving power sequence add RC delay and Discharge circuit.	Add R1765, C1804 for delay +3V_run circuit. Add non-populate component. Q26, Q28, R1803, R1766.	0.5
162	58	H/W	10/29	Steven	For pop option 8632 shutdown pin source Add two resistor.	Add Non-populate R1802 and Populate component R1801. For Pop option 8632 Enable source.	0.5
163	41	H/W	11/03	Steven	Populate the HDD power switch circuit	Pop Q51, R507, Q50 and Depop PJP24.	0.5
164	31	H/W	11/03	Steven	For passing EMVCo test.	Change R1424 from 220 to 330Ohm.	0.5
165	43	H/W	11/03	Steven	SNIFFER_LED_OFF# is a push/pull signal.	De-pop R1449.	0.5
166	27	H/W	11/03	Steven	To improve audio quality	Change C199 to 0.022uF and pop R164, depop R170.	0.5
167	39	H/W	11/11	Steven	Change SMSC MEC5004 from version C to D.	Change U216 P/N to D version. Depop R102, R97, R25, R23, R104, D2002, Q19, Q20, C22. And change C1769 value from 22UF to 4.7UF.	0.5
168	56	H/W	11/11	Steven	Change VRAM parts to K4D553235F-VC33 as DELL request.	Change VRAM P/N to K4D553235F-VC33 (SA55323000L).	0.5
169	39	H/W	11/11	Steven	Change DOCK_SMB_CLK and DOCK_SMB_DAT for consistent with other M07 platforms.	Change R99 and R100 resistor from 100K to 8.2K Ohm. And R1618 change to 10K.	0.5
170	42	H/W	11/11	Steven	Provide pull-up resistor to GFX_CORE_PWRGD for 1.2Vrun power used.	Pop R2170 for provide pull-up resistor.	0.5
171	43	H/W	11/11	Steven	For improve LED brightness issue.	Change R2 value from 560hm to 330ohm. And modified R15 from 150ohm to 100ohm.	0.5
172	28	H/W	11/12	Steven	For Q68 broken issue. Modified R120 value for protect base pin.	Change R120 from 00hm to 2KOhm.	0.5
173	20	H/W	11/12	Steven	For DELL request change D32 and D2005 to RB500.	Change D32 and D2005 from RB751 to RB500.	0.5
174	27	H/W	11/12	Steven	For improve Audio THD+n performance.	Change C113, C114 and C146 from 1UF to 2.2U.	0.5
175	27	H/W	11/22	Steven	For adjust Audio gain to 15.6DB.	Pop R170, De-pop R164.	0.5
176	42	H/W	12/06	Steven	For improving SUSPWROK turn on issue.	Modified Q7 to 2N7002.	0.6
177	23, 38	H/W	12/06	Steven	For solving HD warn boot parking sound issue.	Change HDDC_EN#, MODC_EN# from ICH7 to ECE5018 Pin 106, 107 (GPIOH2/3), and Depop R2148, R2149.	0.6
178	7	H/W	12/06	Steven	Add a De-pop resistor for CPU test 1 PIN.	Add De-pop resistor R1387.	0.6
179	39	H/W	12/07	Steven	Add an damping resistor for improving SPI_CS# overshoot issue.	Add 470hm resistor R127.	0.6

PROPRIETARY NOTE: THIS SHEET OF ENGINEERING DRAWING AND SPECIFICATIONS CONTAINS CONFIDENTIAL TRADE SECRET AND OTHER PROPRIETARY INFORMATION OF DELL INC. ("DELL") THIS DOCUMENT MAY NOT BE TRANSFERRED OR COPIED WITHOUT THE EXPRESS WRITTEN AUTHORIZATION OF DELL. IN ADDITION, NEITHER THIS SHEET NOR THE INFORMATION IT CONTAINS MAY BE USED BY OR DISCLOSED TO ANY THIRD PARTY WITHOUT DELL'S EXPRESS WRITTEN CONSENT.

DELL CONFIDENTIAL/PROPRIETARY			
Chaged-List History 2			
Size	Document Number		Rev
	LA-2792		1.0
Date:	Thursday, February 09, 2006	Sheet	66 of 70

Version Change List (P. I. R. List)

Item	Page#	Title	Date	Request Owner	Issue Description	Solution Description	Rev.
179	39	H/W	12/09	Steven	For solving SBAT_SMBDAT rising time over spec issue.	Change R444 to 4.7KOhm resistor.	0.6
180	6	H/W	12/12	Steven	For Gerber Gating list item 14 Depop pullup resistor on ICH_CLKREQ#.	Depop resistor R1761.	0.6
181	38	H/W	12/12	Steven	For Gerber Gating list item 17 Update board ID to A00	Pop R405, depop R419.	0.6
182	31	H/W	12/12	Steven	For Gerber Gating list item 11 add 47pF capacitors to the USB_BIO+/- pins to fix bio sensor ESD issue.	Add 2 capacitor C83, C84 in USB_BIO+/-.	0.6
183	41	H/W	12/14	Steven	For GPIOH[3:2] need, change pullup resistor power plane to always.	Change pullup resistor R2148, R2149 for +3.3V_SUS to +3.3V_ALW.	0.6
184	41	H/W	12/15	Steven	For Gerber Gating list item 18. Change pullup resistor to 10K.	Change pullup resistor R2148, R2149 for 100K to 10KOhm.	0.6
185	39	H/W	12/19	Steven	For Gerber Gating list item 21. Add 0 ohm series resistor to SPI_CS# at MEC5004.	Add series resistor R112 at MEC5004 side.	0.6
186	31	H/W	12/19	Steven	For improving USB BIO sensor EMI issue.	Add Pop L5, and depop resistor R122, R123.	0.6
187	40	H/W	12/20	Steven	For DELL EMI request for add a 0.1uF capacitor in JTPAD.	Add 0.1uF capacitor C54.	0.6
188	28	H/W	12/30	Steven	For Q68 damage issue change form BCP69 to MBT35200 as ZRS solution.	Use MBT35200 to replace Q68. Modified.	0.6
189	7	H/W	12/30	Steven	Intel Design Guide 1.0 to change H_RESET pull-up resistor to 51ohm.	Change resistor R416 to 51ohm.	0.6
190	39	H/W	01/04	Steven	For enable MEC5004 BIOS write protect function.	Pop R139 and de-pop R138.	0.6
191	27	H/W	01/07	Benson	For adjust Audio gain to 21.6 DB.	DePop R170, pop R164.	0.6
192	28	H/W	01/09	Steven	For Q68 issue to reserve soft start circuit.	Change R120 to 0Ohm, and depop C80.	0.6
193	58	H/W	01/09	Steven	For avoiding GPU leakage issue.	Change R2168 pull-up from +3.3V_run to +3.3V_sus.	0.6
194	20	H/W	01/20	Steven	For fixing issue with projector using long cable.	Change R101,R114 from 39 ohm to 0 ohm	0.6
195	19	H/W	01/20	Steven	For stronger the VGS driving in Battery Mode	Change R235 from 200K ohm to 100K ohm	0.6
196	6	H/W	01/20	Steven	The Drive Level too high	Change R32 from 0 ohm to 470 ohm	0.6
197	22	H/W	01/20	Steven	The Negative Resistance too low	Change X1 spec from CL=20pF to 6 pF and C38,C40 from 12pF to 2.2pF	0.6
198	38	H/W	01/20	Steven	The Frequency too high & Drive Level too high	Change Y1 spec from CL=20pF to 12pF and C1451,C1452 from 22P to 15P	0.6
199	31	H/W	01/20	Steven	None	Depop L5 ,pop R122,R123 33 ohm	0.6
200	23	H/W	01/20	Steven	To fix PLTRST_DELAY# glitch	Change R74 from 0 ohm to 10K ohm and pull-down it	1.0
201	23	H/W	02/06	Steven	For solving USB strength issue.	Change R113 from 22.6Ohm to 22Ohm.	0.6
202	39	H/W	02/08	Steven	For solving primary battery hand issue.	Change R447, R449, R444, R131 to 2.2KOhm.	0.6
203	07	H/W	02/09	Steven	For ESD protection	Depop R424	0.6

PROPRIETARY NOTE: THIS SHEET OF ENGINEERING DRAWING AND SPECIFICATIONS CONTAINS CONFIDENTIAL TRADE SECRET AND OTHER PROPRIETARY INFORMATION OF DELL INC. ("DELL") THIS DOCUMENT MAY NOT BE TRANSFERRED OR COPIED WITHOUT THE EXPRESS WRITTEN AUTHORIZATION OF DELL. IN ADDITION, NEITHER THIS SHEET NOR THE INFORMATION IT CONTAINS MAY BE USED BY OR DISCLOSED TO ANY THIRD PARTY WITHOUT DELL'S EXPRESS WRITTEN CONSENT.

DELL CONFIDENTIAL/PROPRIETARY			
Chaged-List History 2			
Size	Document Number	Rev	
	LA-2792	1.0	
Date:	Thursday, February 09, 2006	Sheet	67 of 70

Version Change List (P. I. R. List)

Item	Page#	Title	Date	Request Owner	Issue Description	Solution Description	Rev.
1	46	PWR	06/01	Saha	M4 input current more than MAX8734 LDO3 output 100mA	Delete PU17 SN74AHC1G32DCKR OR GATE(SA00732018L), PR49 1K_0402_1%(SD03410018L) Add PR350 0_0402_5%(SD02800008L) connect LDO3 to ON3 PU18 74AHC1G08GW AND GATE(SA00000L30L) PR352 1K_0402_1%(SD03410018L) PR351 0_0402_5%(SD02800008L)	0.2 0.2
2	46	PWR	06/01	Saha	MAX8734 LDO soft start issue.	Delete PR27 4.7_1210_5%(SD000007E8L) Un-pop PC20 4.7U_1206_25V6K(SE093106M8L)	0.2
3	46	PWR	06/01	Saha	PWR_SRC noise issue	Un-pop PC252 100U_25V_M(SF10004M008)	0.2
4	44/45	PWR	06/01	Saha	+3VALW change to +3VSRC	Rename net +3VALW to +3VSRC	0.2
5	47	PWR	06/01	Saha	VCCP high/low side MOSFET change from IR to Infineon No-stuff PC207 and PC208	PQ38 change from IR7821(SB57821008L) to BSO072N03S(SB00000418L) PQ40 change from IR7832(SB57832008L) to BSO072N03S(SB00000418L) Un-pop PC207 and PC208 10U_0805_6.3V5K(SE093106M8L)	0.2
6	47	PWR	06/01	Saha	VCCP_1P05VP OCP issue(5A)	PR224 change from 124K_0402_1%(SD03412438L) to 60.4K_0402_1%(SD03460428L)	0.2
7	47/48	PWR	06/01	Saha	Choke height issue.(5.6mm change to 5.0mm)	PL14 and PL27 change from 1.4U_HMU1356-1R4_15.5A H5.6mm(SH04814AM8L) to 1.4U_HMU1350-1R4_15A H5.0mm(SH000004H8L)	0.2
8	44	PWR	06/01	Saha	PSID materiel change by Dell	PQ1 change from BSS138_SOT23(SB50138008L) to FDV301_SOT23(SB50301008L)	0.2
9	50	PWR	06/01	Saha	New version MAX8731 PIN1 define GND	Un-pop PR337 0_0402_5%(SD02800008L),Pop PR336 0_0402_5%(SD02800008L)	0.2
10	50	PWR	06/02	Saha	Add RC filter at pin 23 of MAX8731	Add PR360 1_0603_1%(SD014100B8L) PC253 220P_0402_50V7K(SE074221K8L)	0.2
11	46/48	PWR	06/02	Saha	Add support for Reliability voltage margining tests	Add PR356, PR355 and PR359 0_0603_5%(SD01300008L) PR353 and PR354 0_0402_5%(SD02800008L)	0.2
12	48	PWR	06/16	Saha	Change output capactor rating voltage from 6.3V to 2.5V	PC70 and PC71 change from 330U_D3L_6.3V_R25(SGA00000N8L) to 330U_D2E_2.5VM_R15(SGA19331D0L)	0.3
13	49	PWR	06/22	Saha	Change VCORE DPRSLPVR input resistor value	PR248 change from 0_0402_5%(SD02800008L) to 499_0402_1%(SD03449900L)	0.3
14	50	PWR	06/22	Saha	Add power limit schematic	Depop PR361 80.6K_0402_1%, PR362 200K_0402_1%, PR363 121K_0402_1%, PR364 3.01K_0402_1%, PR365 499K_0402_1%, PR366 100K_0402_1%, PR367 100K_0402_1%, PC254 0.01U_0402_25V8K, PC255 100P_0402_50V8K, PC256 100P_0402_50V8K, PC257 100P_0402_50V8K, PC258 0.01U_0402_25V8K, PC259 10P_0402_50J8K, PQ81 RHU002N06_SOT323, PU19 LM393DR_SO8	0.3
15	46	PWR	06/29	Saha	Discreate 3VALW and 3VSRC.	Add PU17 SN74AHC1G32DCKR OR GATE(SA00732018L), PR49 1K_0402_1%(SD03410018L) PQ82 FDC655BN_NL(SB000004P8L) Delete PR352 1K_0402_1%(SD03410018L) PR351 0_0402_5%(SD02800008L) PR350 0_0402_5%(SD02800008L) PU18 74AHC1G08GW AND GATE(SA00000L30L)	0.3

PROPRIETARY NOTE: THIS SHEET OF ENGINEERING DRAWING AND SPECIFICATIONS CONTAINS CONFIDENTIAL TRADE SECRET AND OTHER PROPRIETARY INFORMATION OF DELL INC. ("DELL") THIS DOCUMENT MAY NOT BE TRANSFERRED OR COPIED WITHOUT THE EXPRESS WRITTEN AUTHORIZATION OF DELL. IN ADDITION, NEITHER THIS SHEET NOR THE INFORMATION IT CONTAINS MAY BE USED BY OR DISCLOSED TO ANY THIRD PARTY WITHOUT DELL'S EXPRESS WRITTEN CONSENT.

DELL CONFIDENTIAL/PROPRIETARY		
Changed-List History 1		
Size	Document Number	Rev
	LA-2792	1.0
Date:	Thursday, February 09, 2006	Sheet 68 of 70

Version Change List (P. I. R. List)

Item	Page#	Title	Date	Request Owner	Issue Description	Solution Description	Rev.
16	46	PWR	06/29	Saha	Add V+ input Resistor	Add PR27 0_1206_5%(SD00100000L)	0.3
17	45/51	PWR	06/29	Saha	Battery conn. and battery selector +3VSRC change to +3VALW	Rename +3VSRC to +3VALW	0.3
18	47	PWR	06/29	Saha	ISL6227 Issue change 1.05V/1.5VHigh/Low side MOSFET change 1.05V choke adjust OCP and ISEN value	VCC Change from +5VRUN to +5VSUS. EN1 and EN2 change from RUNPWROK to RUN_ON. PR221 change from 20K_04-2_1%(SD03420028L) to 19.6K_0402_1%(SD00000358L) PQ8 change from FDS6994S(SB56994008L) to FDS8880(SB000004U8L) Add PQ83 FDS6670AS(SB000004T8L) PQ38 change from BSO072N03S(SB00000418L) to FDS8880(SB000004U8L) PQ40 change from BSO072N03S(SB00000418L) to FDS6670AS(SB000004T8L) PL27 change from 1.4U_HMU1350(SH000004H8L) to 1.5U_SIL104(SH04215A08L) Add PC261 0.01U_0402(SE068103K8) Add PC262 and PC263 2200P_0402(SE074222K8L) PR219 change from 825_0402_1%(SD03482508L) to 1.43K_0402_1%(SD03414318L) PR220 change from 825_0402_1%(SD03482508L) to 2.1K_0402_1%(SD03421018L) PR223 change from 69.8K_0402_1%(SD03469828L) to 124K_0402_1%(SD03412438L) PR224 change from 60.4K_0402_1%(SD03460428L) to 124K_0402_1%(SD03412438L)	0.3
19	49	PWR	06/29	Saha	ISL6260 Issue	Delete PR338, PR339 and PR340 2.7_0603_5% Change PC246, PC247, PC248 to 1500P_0805-----Unpop Change PH1 from ERTJ1VR103J(SL20000020L) to NCP15WM474J03RB(SL20000098L) PR284 change from 15.8K_0402_1%(SD03415828L) to 0_0402_5%(SD02800008L) Add PC260 0.1U_0603(SE042104K8L)	0.3
20	50	PWR	06/29	Saha	Change +VCHGR output CAP from 1206 to 1210	PC113 and PC114 change from 10U_1206(SE142106M8L) to 10U_1210(SE056106K8L)	0.3
21	47	PWR	08/12	Saha	Add VSEN capacitor	Add PC265 and PC264 100P_0402_50V8K(SE071101K8L)	0.4
22	47	PWR	08/12	Saha	Delete PGOOD pull high resistor	Delete PR283 100K_0402_1%(SD03410038L) De-pop PR195 100K_0402_1%(SD03410038L)	0.4
23	48	PWR	08/12	Saha	Delete reliability test resistor	Delete PR283 110K_0603_1%, PR359 0_0603_1%, and PR82 59.6K_0603_1%	0.4
24	49	PWR	08/12	Saha	Adjust VCORE load line	PR267 change from 7.87K_0402_1%(SD03478718L) to 9.09K_0402_1%(SD034909100) PR231, PR331, and PR270 change from 7.68K_0402_1%(SD00000238L) to 7.68K_0805_1%(SD00000B08L)	0.4
25	49	PWR	08/12	Saha	Delete H_PROCHOT# resistor	Delete PR235 0_0402_5%(SD02800008L)	0.4
26	50	PWR	10/17	Saha	Add RC filter in FBSA/B PIN	Add PR368 and PR369 100_0402_5%(SD02810008L) Add PC266 and PC267 0.01U_0603_50V7K(SE025103K8L) Un-pop PR371 and PR370 0_0402_5%	0.5
27	46	PWR	10/17	Saha	EMI request: change BST3 resestor	Change PR32 from 0_0603_5%(SD01300008L) to 2.2_0603_5%(SD013220B8L)	0.5
28	46	PWR	10/17	Saha	change 3V out put CAP height	change PC31 from 330U_6.3V_R25 H1.9(SGA00001C8L) to 330U_6.3V_R25 H2.8(SGA0000089L)	0.5

PROPRIETARY NOTE: THIS SHEET OF ENGINEERING DRAWING AND SPECIFICATIONS CONTAINS CONFIDENTIAL TRADE SECRET AND OTHER PROPRIETARY INFORMATION OF DELL INC. ("DELL") THIS DOCUMENT MAY NOT BE TRANSFERRED OR COPIED WITHOUT THE EXPRESS WRITTEN AUTHORIZATION OF DELL. IN ADDITION, NEITHER THIS SHEET NOR THE INFORMATION IT CONTAINS MAY BE USED BY OR DISCLOSED TO ANY THIRD PARTY WITHOUT DELL'S EXPRESS WRITTEN CONSENT.

DELL CONFIDENTIAL/PROPRIETARY			
Changed-List History 2			
Size	Document Number	Rev	
	LA-2792	1.0	
Date:	Thursday, February 09, 2006	Sheet	69 of 70

Version Change List (P. I. R. List)

Item	Page#	Title	Date	Request Owner	Issue Description	Solution Description	Rev.
29	50	PWR	10/17	Saha	Populate UL circuit	Populate PR361-PR367, PC254-259, PU19, PQ81. Change PR361 from 80.6k to 0. Change PR362 from 200k to 301k. Change PR363 from 121k to 59k. Change PR364 from 3.01k to 27.4k. Change PR365k from 499k to 4.32Meg.	0.5
30	49	PWR	10/20	Saha	Change VCC_CORE OCP, SOFT, and DPRSTP# value	PR260 change from 20K_0402_1%(SD03420028L) to 11.5K_0402_1%(SD03411520L) PC187 change from 0.022U_0402_16V7K(SE076223K8L) to 0.01U_0402_16V7K(SE076103K8L) Add PR372 0_0402_5%(SD02800008L) Delete PR246 0_0402_5%(SD02800008L) Un-pop PR249 0_0402_5%(SD02800008L)	0.5
31	48	PWR	10/20	Saha	Change PU6 BST resistor	PR73 change from 0_0603_5%(SD01300008L) to 1_0603_5%(SD013100B8L)	0.5
32	44	PWR	10/20	Saha	Change PQ2 from RUH002N06 to 3904	PQ2 change from RHU002N06(SB50206008L) to MMST3904(SB000002R0L)	0.5
33	49	PWR	11/12	Saha	Adjust CPU Load Line	PR267 change from 9.09K_0402_1%(SD03490918L) to 10.5K_0402_1%(SD03410528L) PR261 change from 3.57K_0402_1%(SD03435718L) to 2.47K_0402_1%(SD03424318L) Add PC252 100U_25V_(6.3X7.7)(SF10004M08L) Add PC215 0.068U_10VX7R_0402 (SE102683K8L)	0.5
34	50	PWR	12/6	Saha	Deeply discharged battery problem.	Add PD54 1SS355_sod323(SC1SS35500L) Add PR373 1K_0603_1%(SD01410018L)	0.5
35	50	PWR	12/6	Saha	Follow Coe A09 schematic	Add PC267 3300PF_0402_50V7K(SE074332K8L) Depop PC266 0.01U_0603_50V7K(SE025103K8L)	0.5
36	47	PWR	12/15	Saha	Follow GGL 1214 item19.	Depop PR12	0.6
37	49 50 46	PWR	1/7	Saha	For acoustical issue	Add PC270-PC273 and PC268 10U_1206_25V6M(SE142106M8L)	0.6

PROPRIETARY NOTE: THIS SHEET OF ENGINEERING DRAWING AND SPECIFICATIONS CONTAINS CONFIDENTIAL TRADE SECRET AND OTHER PROPRIETARY INFORMATION OF DELL INC. ("DELL") THIS DOCUMENT MAY NOT BE TRANSFERRED OR COPIED WITHOUT THE EXPRESS WRITTEN AUTHORIZATION OF DELL. IN ADDITION, NEITHER THIS SHEET NOR THE INFORMATION IT CONTAINS MAY BE USED BY OR DISCLOSED TO ANY THIRD PARTY WITHOUT DELL'S EXPRESS WRITTEN CONSENT.

			DELL CONFIDENTIAL/PROPRIETARY		
Changed-List History 2					
Size	Document Number				Rev
	LA-2792				1.0
Date:	Thursday, February 09, 2006		Sheet	70	of 70