

# VM9/VM8 Block Diagram

VER : 1A

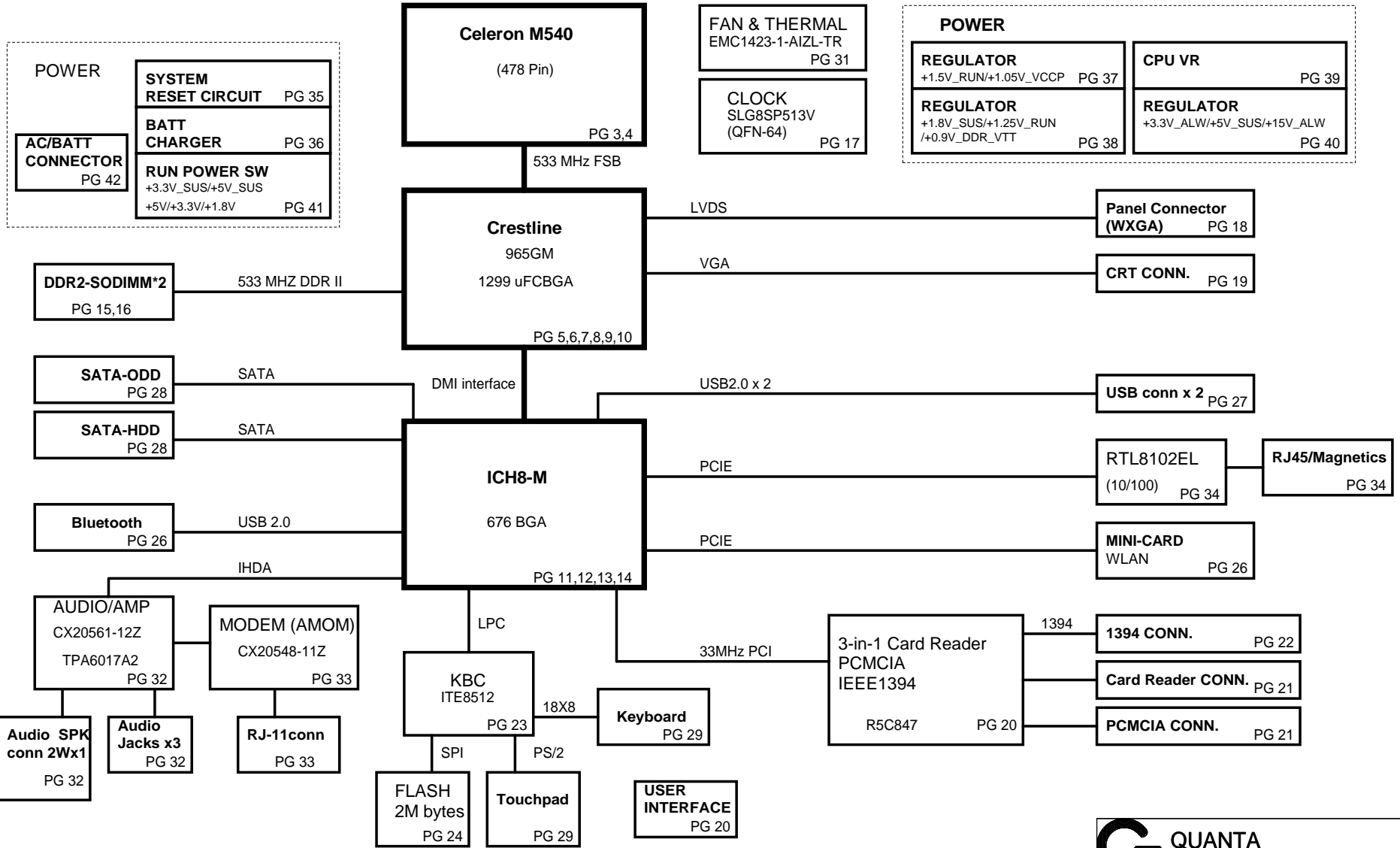

**QUANTA COMPUTER**

Title: Schematic Block Diagram

Size	Document Number VM9/VM8	Rev 1A
Date: Wednesday, June 25, 2008	Sheet 1	of 53

Table of Contents

PAGE	DESCRIPTION
1	Schematic Block Diagram
2	Front Page
3-4	Merom
5-10	Crestline
11-14	ICH8M
15-16	DDRII SO-DIMM(200P)
17	Clock Generator
18	HDMI
23	LCD Conn. & SSP
24	CRT Conn
25	SATA Conn
26-27	CARD READER/Conn & 1394
28	Express Card & Smart Card
29-30	Mini Card
31	SIO (ITE8512)
32	FLASH/RTC
33	USB
35	TP / KEYBOARD
36	SWITCH /LED
37	FAN & Thermal
38-39	Audio CODEC(ALC888)/Phone Jack
40-41	LOM / Switch
44	System Reset Circuit
46	Battery Selector & Charger
48	1.05VCCP / 1.5VRUJN
49	DDR2_1.8VSUS, 0.9V
51	CPU_ISL6266(2phase)
52	MAX8744 (+5.5V,+3.3V)
53	RUN Power Switch
54	DCIN,Batt
55	PAD& SCREW
56	EMI CAP
57	SMBUS BLOCK
58	Power Block Dianram

Power States

POWER PLANE	VOLTAGE	PAGE	DESCRIPTION	CONTROL SIGNAL	ACTIVE IN
+PWR_SRC	10V~+19V	4,26,32,34,46,48,49,51,52,56	MAIN POWER		S0~S5
+RTC_CELL	+3.0V~+3.3V	11,14,31,32	RTC		S0~S5
+3.3V_ALW	+3.3V	3,31,32,34,36,37,38,44,46,49,52,53,54	8051 POWER	ALWON	S0~S5
+5V_ALW	+5V	35,36,46,48,49,52,53,54,56	LCD/CHARGE POWER	ALWON	S0~S5
+15V_ALW	+15V	26,36,37,52,53	LARGE POWER	+5V_ALW	S0~S5
+3.3V_LAN	+3.3V	42,43	LAN POWER	AUX_ON	
+5V_SUS	+5V	14,38,51,53	SLP_S5# CTRLD POWER	SUS_ON	
+3.3V_SUS	+3.3V	3,11,12,13,14,26,30,37,38,43,48,49,51,53	SLP_S5# CTRLD POWER	3.3V_SUS_ON	
+1.8V_SUS	+1.8V	6,8,9,15,48,49,53	SODIMM POWER	DDR_ON	
+0.9V_DDR_VTT	+0.9V	16,49,53	SODIMM POWER	0.9V_DDR_VTT_ON	
+5V_RUN	+5V	14,18,27,36,37,38,39,40,41,53	SLP_S3# CTRLD POWER	RUN_ON	
+3.3V_RUN	+3.3V	14,18,27,36,37,38,39,40,41,53	SLP_S3# CTRLD POWER	3.3V_RUN_ON	
+1.8V_RUN	+1.8V	18,38,53	SDVO POWER	RUN_ON	
+1.5V_RUN	+1.5V	4,9,14,30,33,34,48,53,56	CALISTOGA/ICH8 POWER	1.5V_RUN_ON	
+1.25V_RUN	+1.25V	6,9,14,49,53	CALISTOGA/ICH8 POWER	1.25V_RUN_ON	
+1.05V_VCCP	+1.05V	3,4,5,6,8,9,11,14,48,56	CPU/CALISTOGA/ICH8 POWER	1.05V_RUN_ON	
+VCC_CORE	+0.7V~+1.77V	4,51,56	CPU CORE POWER	IMVP_VR_ON	
+LCDVCC	+3.3V	26	LCD Power	LCDVCC_TST_EN & ENVDD	
+5V_MOD	+5V	36	Module Power	MODC_EN#	
+5V_HDD	+5V	36	HDD Power	HDCC_EN#	
+PBATT	+10V~+17V		MAIN BATTERY	CHG_PBATT	
+SBATT	+10V~+17V		SECOND BATTERY	CHG_SBATT	

GND PLANE	PAGE	DESCRIPTION
⏚ 8731AGND	46	
⏚ AGND_0.9V	49	
⏚ AGND_DC/DC	52	
⏚ AGND_DC2	48	
⏚ AGND_DDR	49	
⏚ AGND_ISL6260	51	
⏚ GND	ALL	



Title			Index & Power Status
Size	Document Number	Rev	
	VM9/VM8	1A	
Date:	Wednesday, June 25, 2008	Sheet	2 of 53

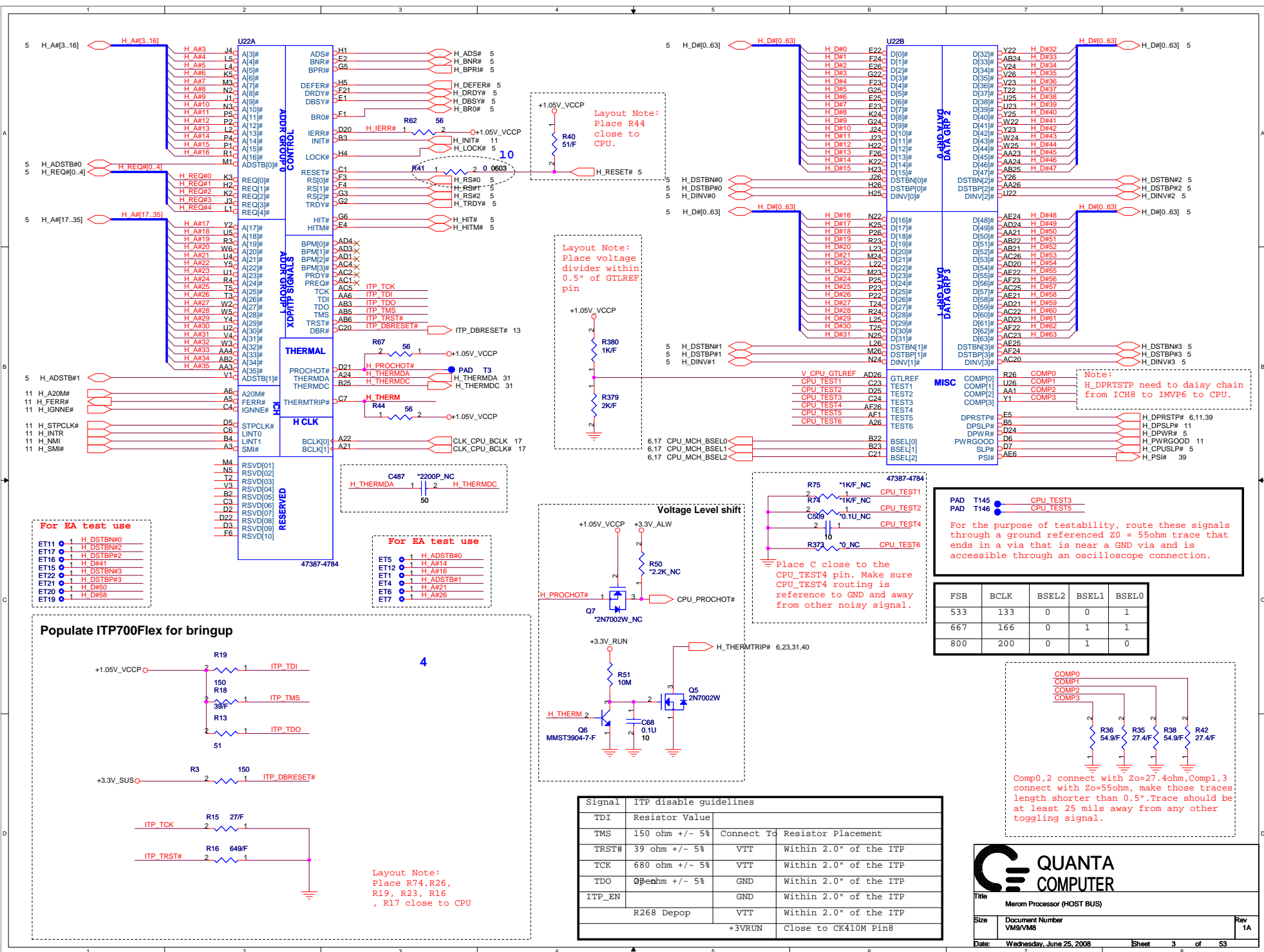



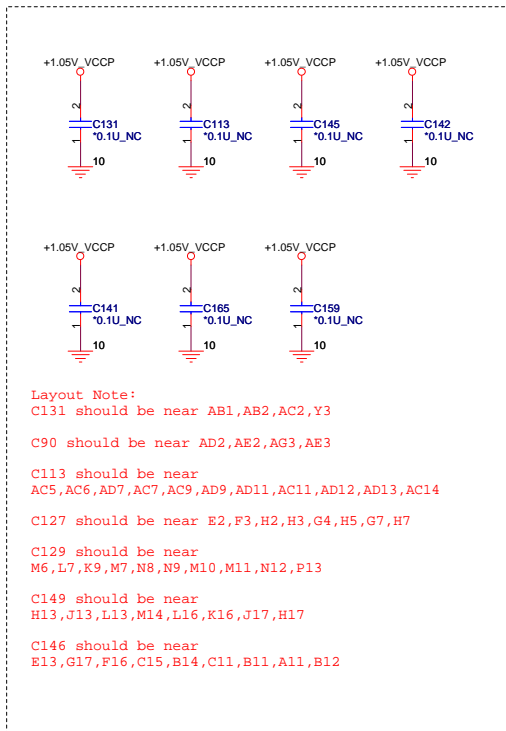
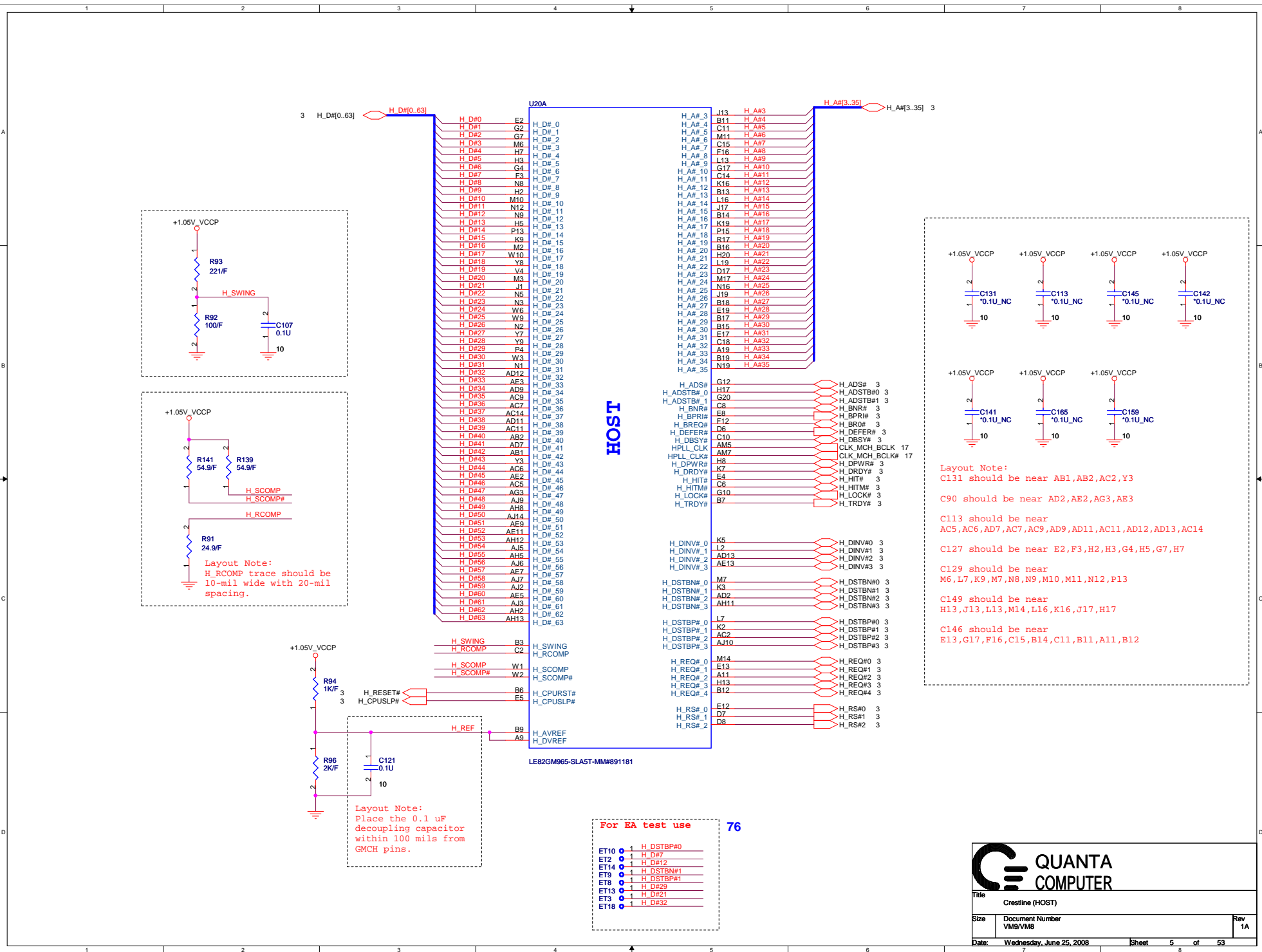

**Layout Note:**  
C113 should be near AC5, AC6, AD7, AC7, AC9, AD9, AD11, AC11, AD12, AD13, AC14  
C127 should be near E2, F3, H2, H3, G4, H5, G7, H7  
C129 should be near M6, L7, K9, M7, N8, N9, M10, M11, N12, P13  
C149 should be near H13, J13, L13, M14, L16, K16, J17, H17  
C146 should be near E13, G17, F16, C15, B14, C11, B11, A11, B12



Title		Crestline (HOST)	
Size	Document Number	Rev	
	VM9/VM8	1A	
Date:	Wednesday, June 25, 2008	Sheet	5 of 53



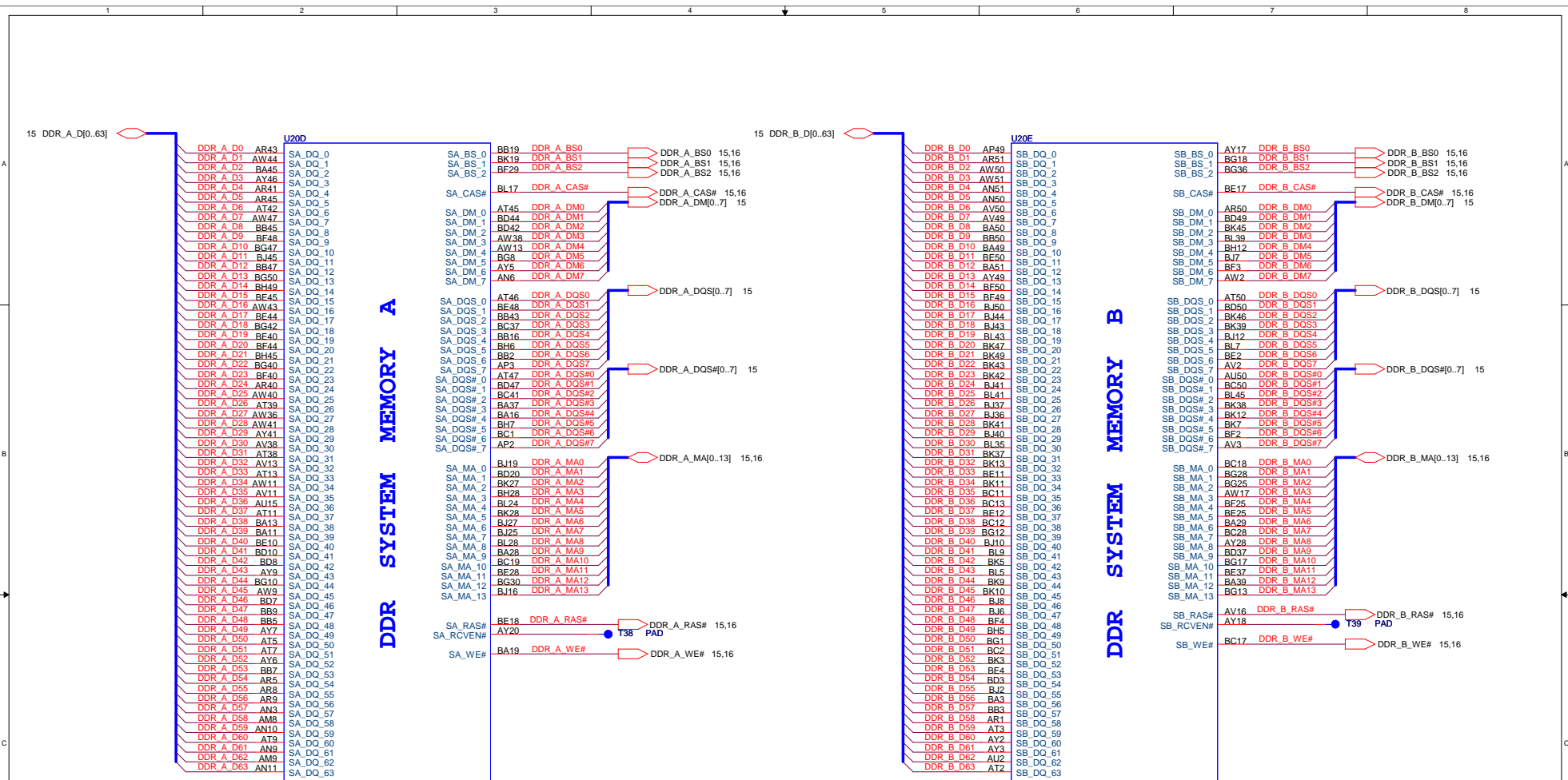

LE82GM965-SLA5T-MM#891181

LE82GM965-SLA5T-MM#891181

- 76: For EA test use
- ET42 1 DDR A CAS#
  - ET37 1 DDR A RAS#
  - ET31 1 DDR A WE#
  - ET39 1 DDR CS0 DIMMA#
  - ET32 1 DDR A MA0
  - ET28 1 DDR A DQS0
  - ET27 1 DDR A DQS#0
  - ET23 1 DDR A D55
  - ET28 1 DDR A D22
  - ET40 1 DDR A D22
- DDR\_CS0\_DIMMA# 6,15,16

- 76: For EA test use
- ET36 1 DDR B CAS#
  - ET37 1 DDR B RAS#
  - ET33 1 DDR B WE#
  - ET38 1 DDR CS3 DIMMB#
  - ET35 1 DDR B MA11
  - ET41 1 DDR B MA1
  - ET24 1 DDR B DQS0
  - ET25 1 DDR B DQS#0
  - ET30 1 DDR B D8
  - ET34 1 DDR B D41
  - ET43 1 DDR B D41
- DDR\_CS3\_DIMMB# 6,15,16

**QUANTA COMPUTER**

Title: Crestline (DDR2)

Size	Document Number VM9/VM8	Rev 1A
------	-------------------------	--------

Date: Wednesday, June 25, 2008 Sheet 7 of 53

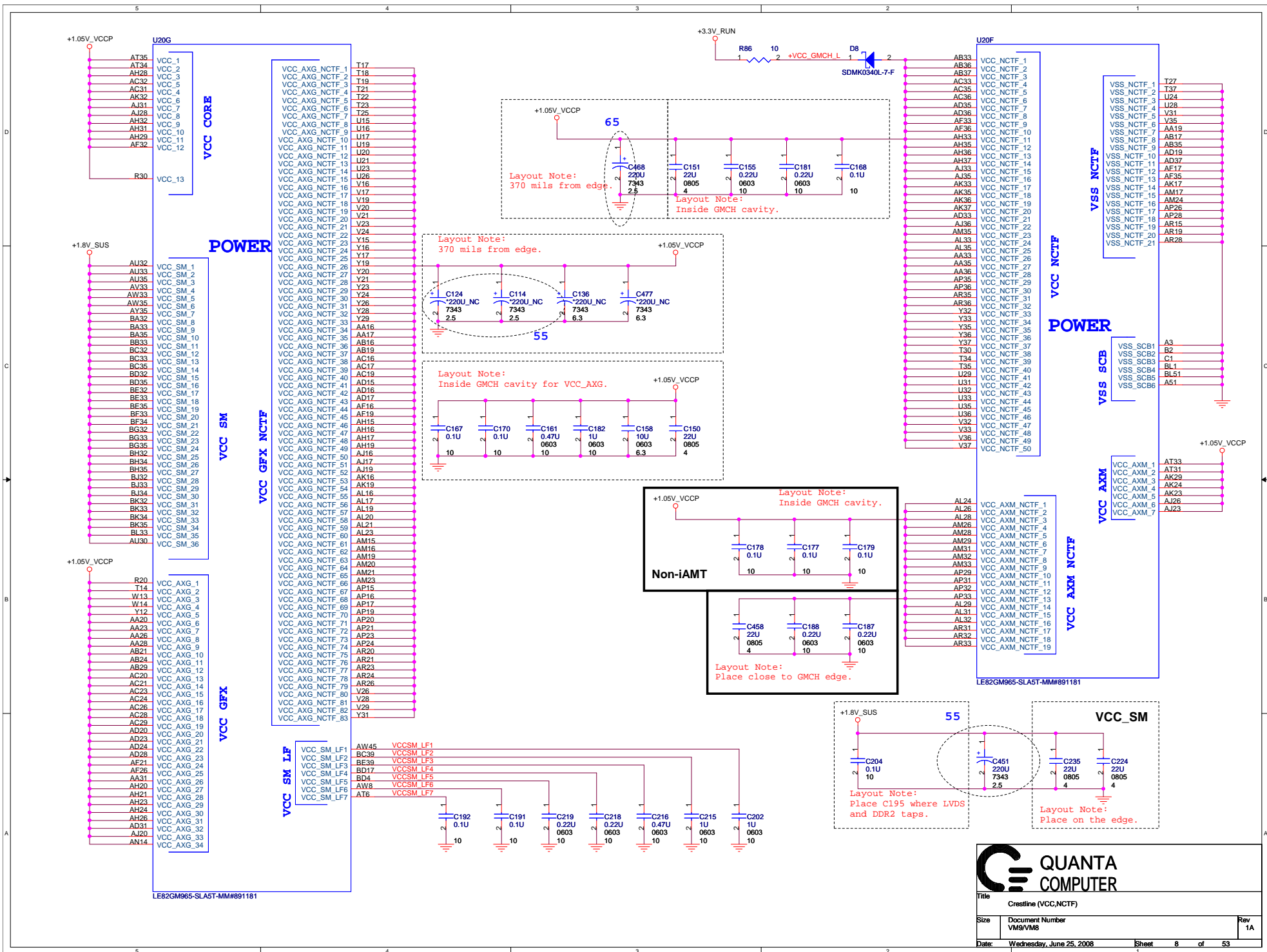

**QUANTA COMPUTER**

Title: Crestline (VCC,NCTF)

Size	Document Number VMS/VMB	Rev 1A
Date: Wednesday, June 25, 2008	Sheet 8 of 53	





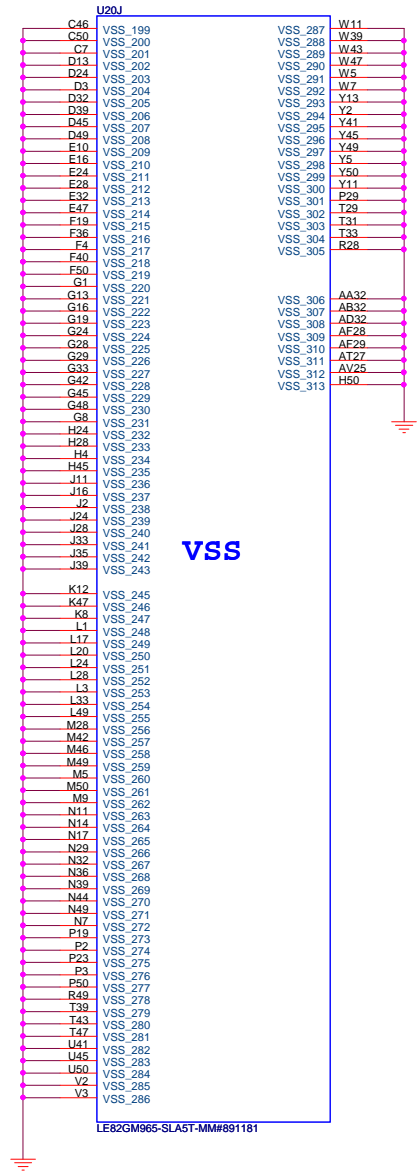
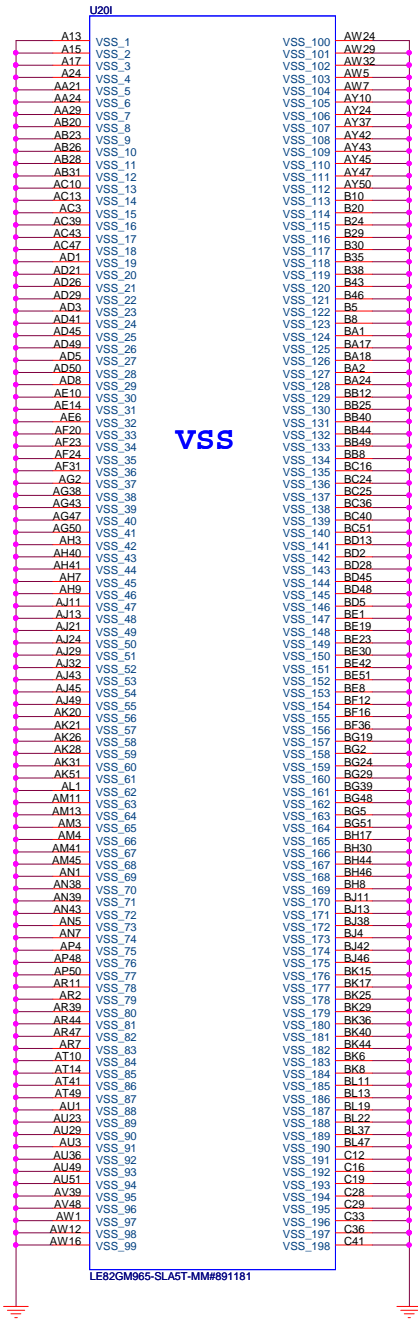

**QUANTA COMPUTER**

Title: Crestline (VSS)

Size	Document Number VM9/VM8	Rev 1A
------	-------------------------	--------

Date: Wednesday, June 25, 2008 Sheet 10 of 53



Place TX DC blocking caps close ICH8.

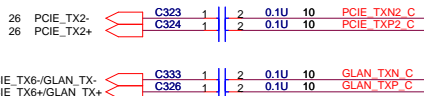

For EA test use

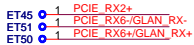

76

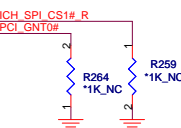
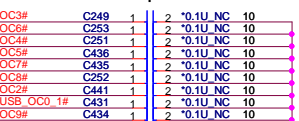
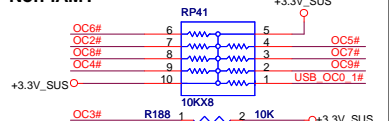

Table for Boot BIOS Strap with columns for component, GNT0#, and SPI\_CS1#.

WWAN Noise - ICH improvements



Non-iAMT



20.25 PCI\_AD[0..31]

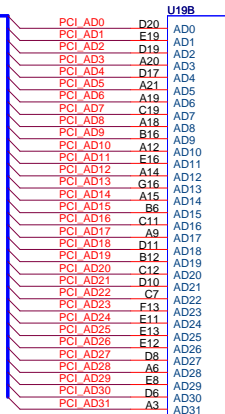

PCI

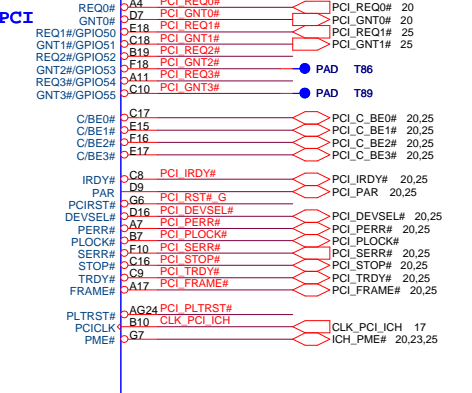

Interrupt I/F

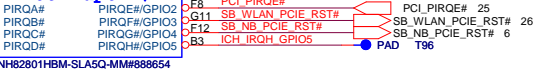

NH82801HBM-SLA50-MM#888654

U19D

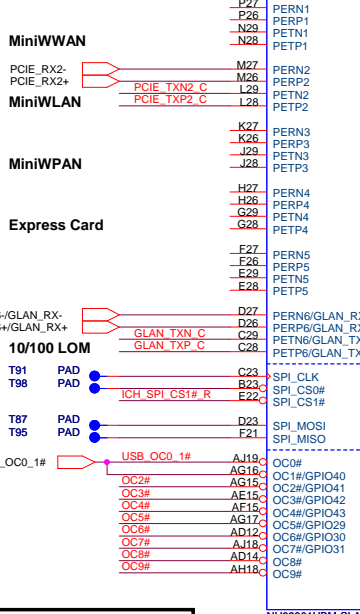

Direct Media Interface

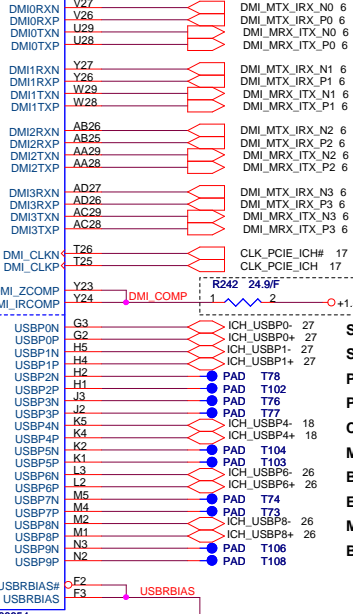

NH82801HBM-SLA50-MM#888654

Short F2 and F3 at the package and keep length to less than 500mils. Trace Impedance should be 60ohms +/- 15%.

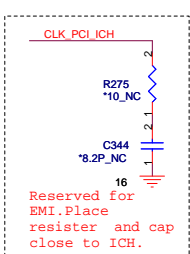
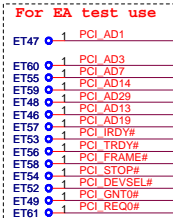
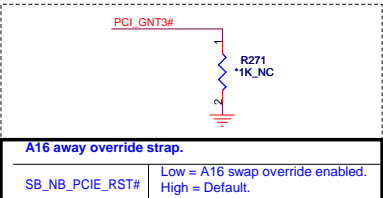

Side pair Top / left

Side pair bottom / right

Pair 1 top / left

Pair 1 bottom / right

Camera

Mini Card (WWAN)

Bluetooth

Express Card

Mini Card (WLAN)

Biometric

PCI Pullups

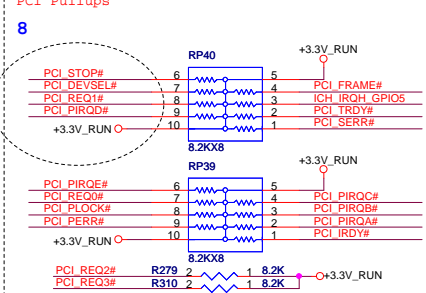

Non-iAMT

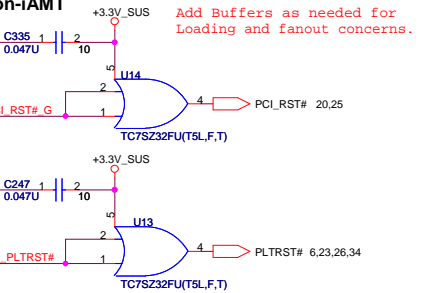
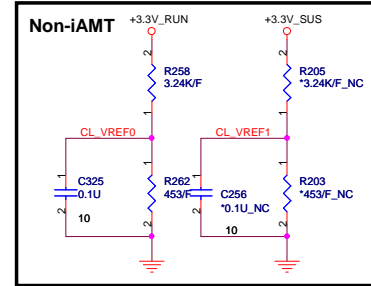
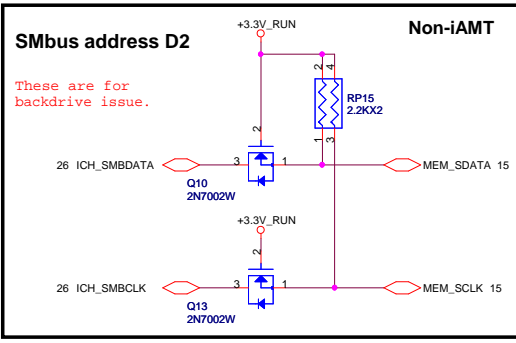
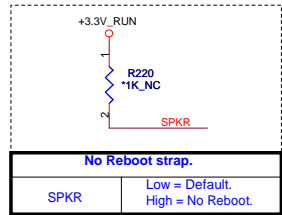
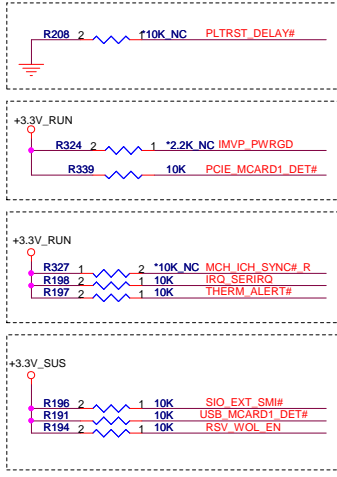
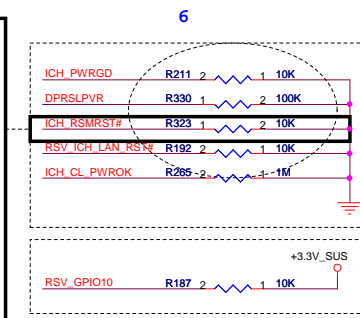
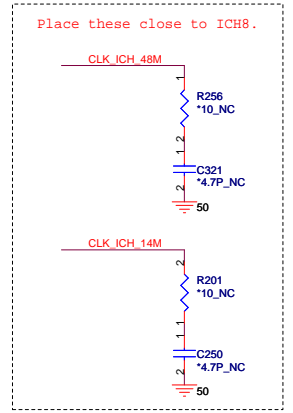
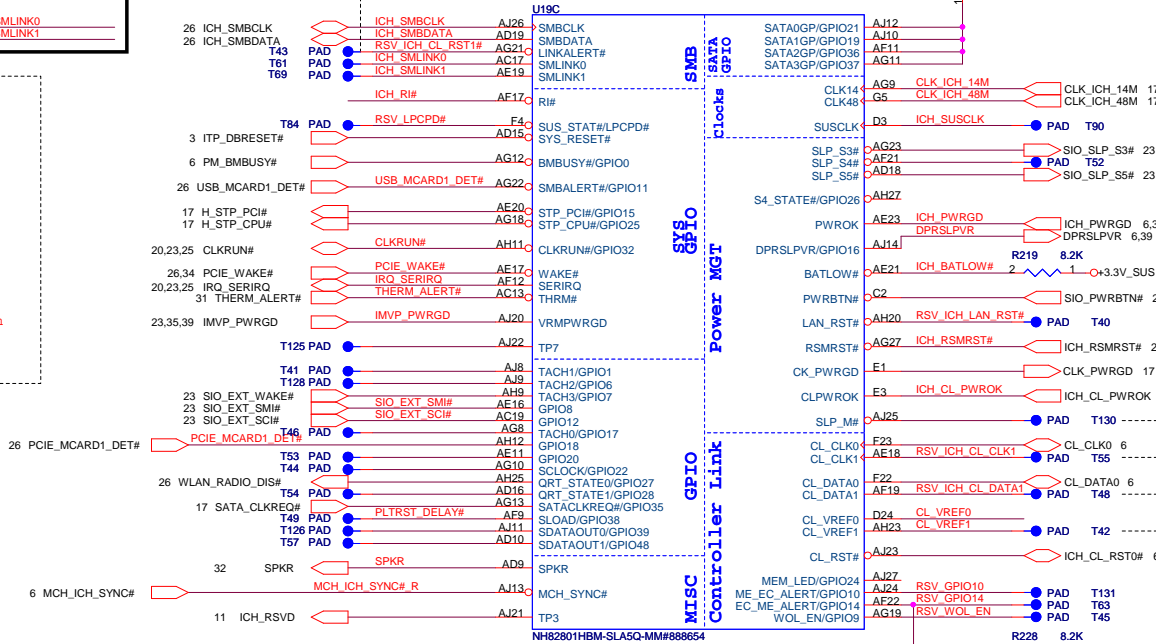
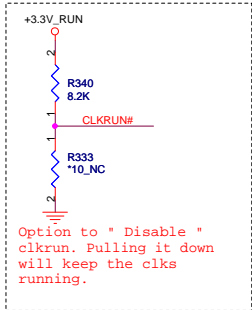
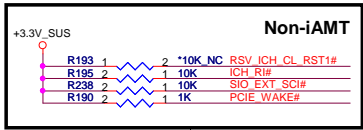
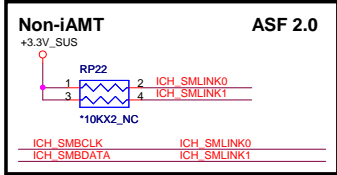
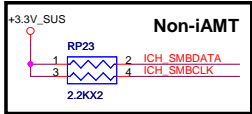

Table with document information: Title (ICH8-M (USB,DMI,PCIE,PCI)), Document Number (VM9/VM8), Rev (1A), Date (Wednesday, June 25, 2008), Sheet (12 of 53).



**Non-iAMT**



Title: ICH8-M (PM,GPIO,SMB,CL)		
Size: VM9/VMB	Document Number: VM9/VMB	Rev: 1A
Date: Wednesday, June 25, 2008	Sheet: 13	of 53



A is required to route to Top SoDIMM for AMT to function. Ch.A SODIMM needs to be populated for Intel AMT support.

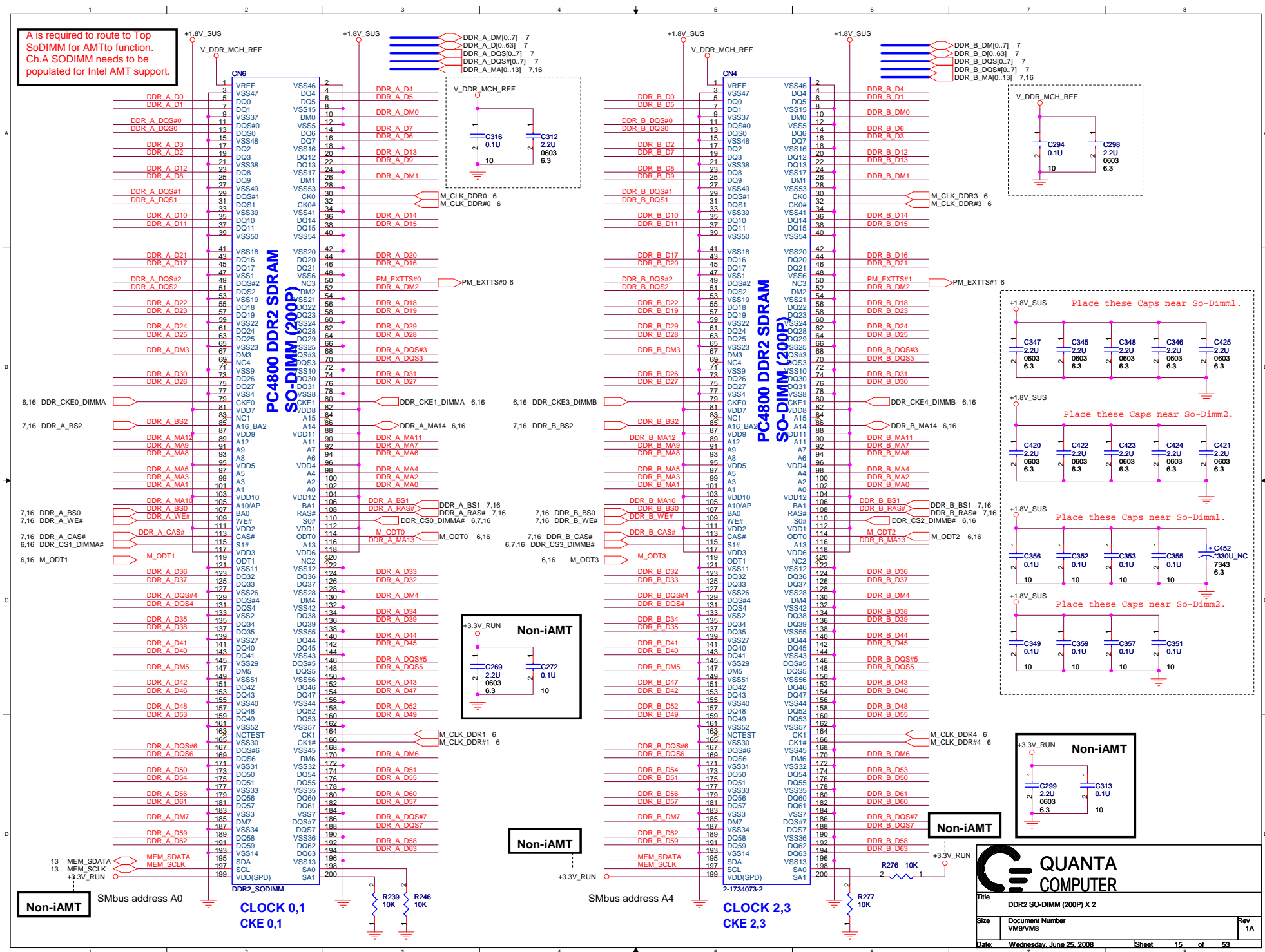

Place these Caps near So-Dimm1.

Place these Caps near So-Dimm2.

Place these Caps near So-Dimm1.

Place these Caps near So-Dimm2.

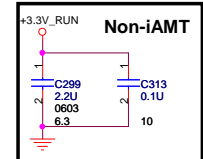
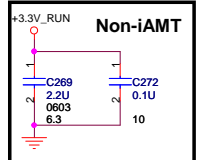

Non-iAMT

Non-iAMT

Non-iAMT

**QUANTA COMPUTER**

Title: DDR2 SO-DIMM (200P) X 2

Size	Document Number V19/V18	Rev	1A
------	-------------------------	-----	----

Date: Wednesday, June 25, 2008 Sheet 15 of 53

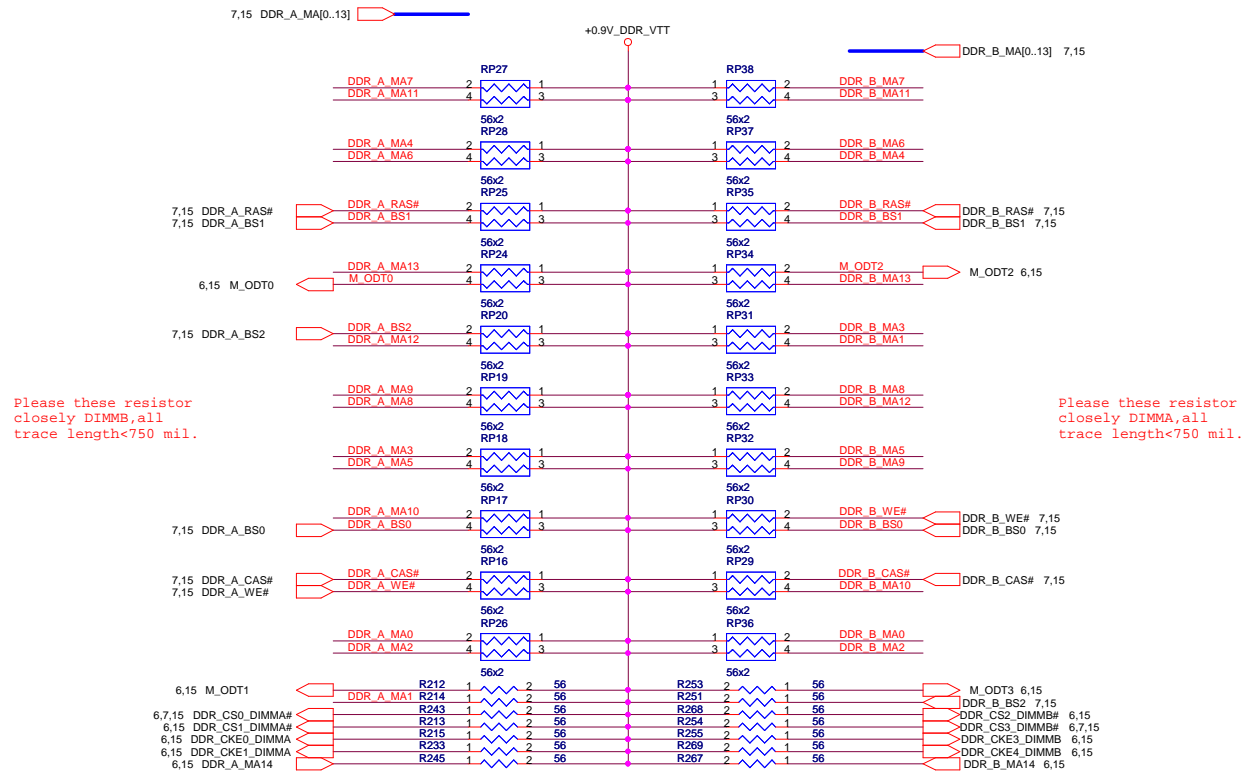
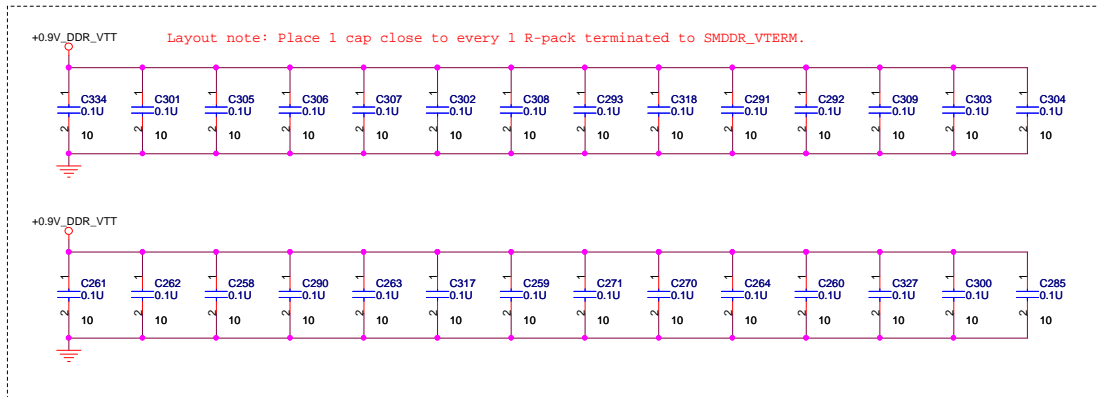

Title: DDR2 RES ARRAY

Size	Document Number VM9/VM8	Rev 1A
------	----------------------------	-----------

Date: Wednesday, June 25, 2008 Sheet 16 of 53



Add capacitor pads for improving WWAN.

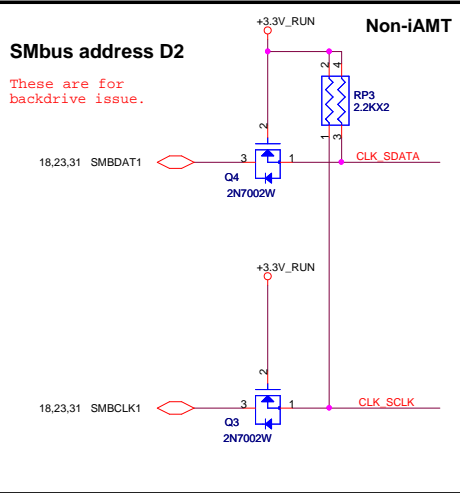
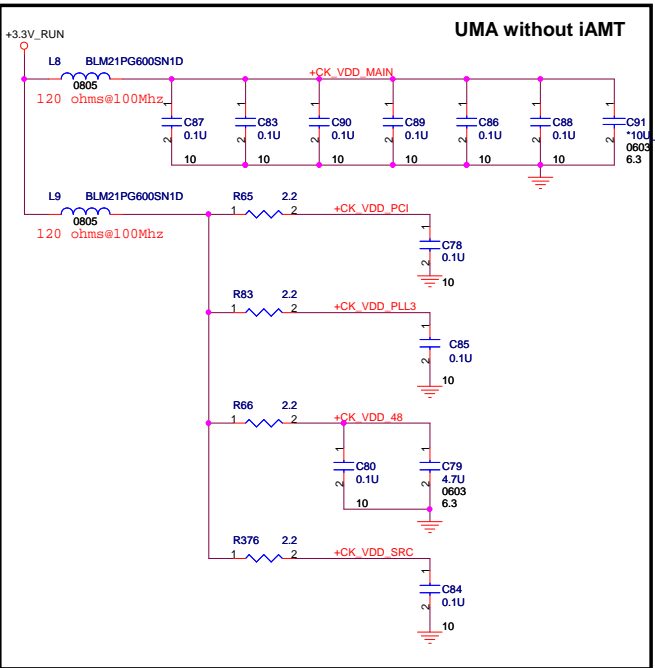
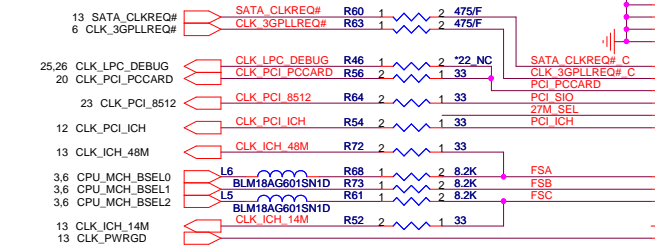
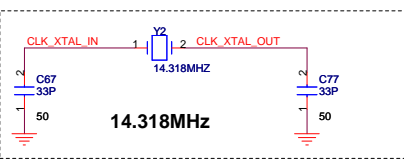
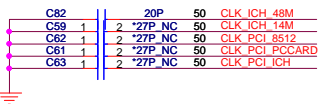

SMbus address D2  
These are for backdrive issue.

### CK505 QFN64

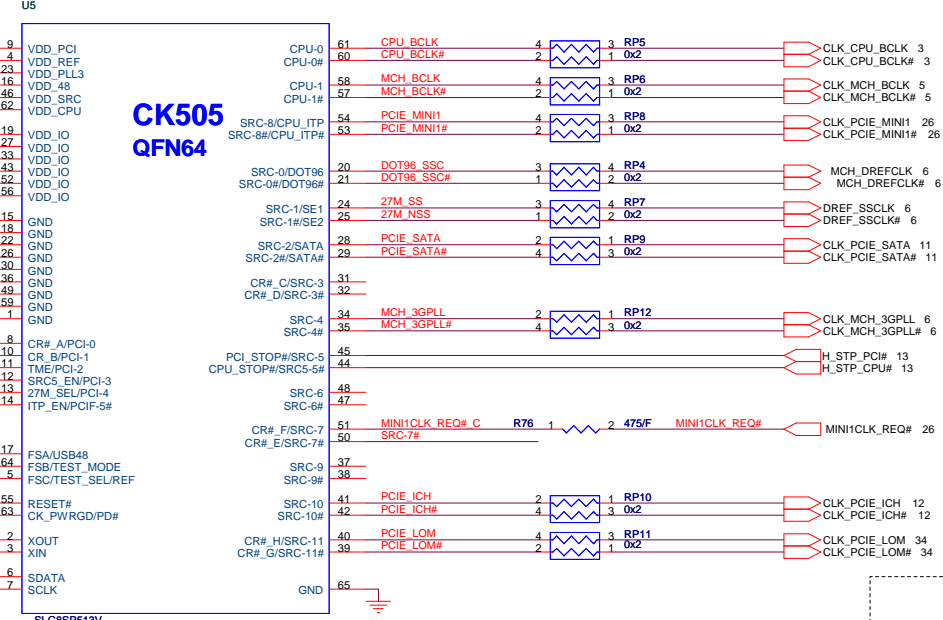

Silego need pull up but other?

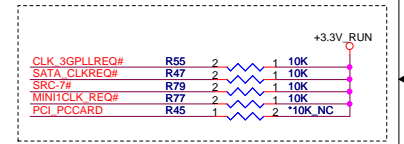

FSC	FSB	FSA	CPU	SRC	PCI
1	0	1	100	100	33
0	0	1	133	100	33
0	1	1	166	100	33
0	1	0	200	100	33
0	0	0	266	100	33
1	0	0	333	100	33
1	1	0	400	100	33
1	1	1	RSVD	100	33

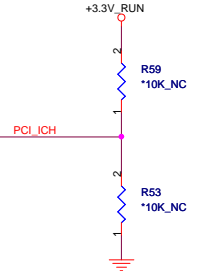

R185 POP: For Internal pull-low.  
R439 POP: For internal pull-high.

27M_SEL (PIN13)	PIN20	PIN21	PIN24	PIN25
0=UMA	DOT96T	DOT96C	96/100M_T	96/100M_C
1 = Disc. GFRX down	SRCT0	SRCC0	27Mout	27MSSout



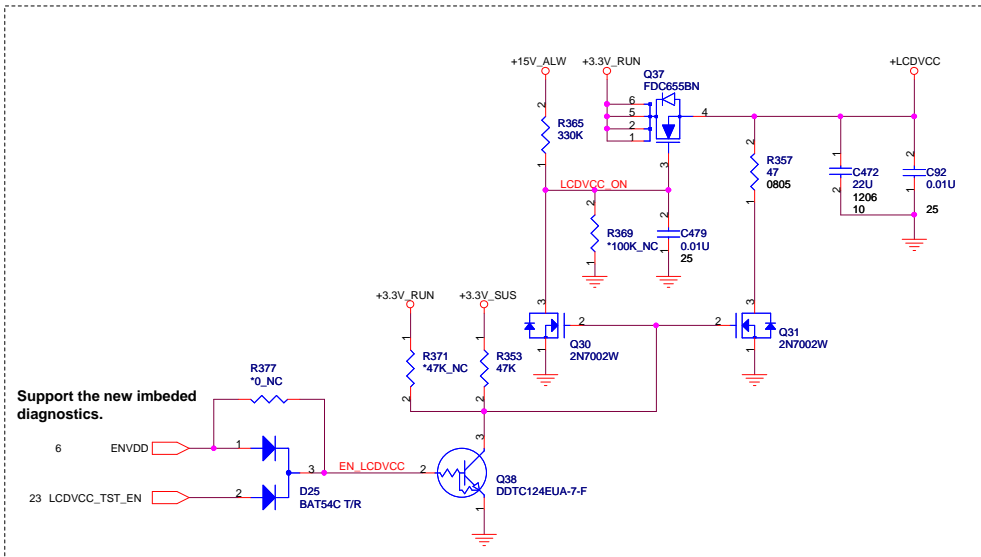

Support the new imbedded diagnostics.

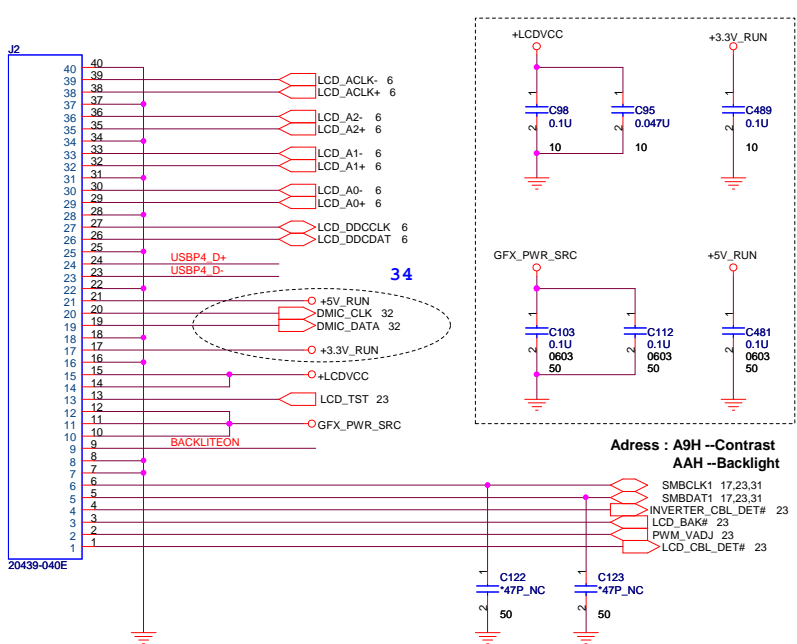

Adres : A9H -- Contrast  
AAH -- Backlight

**UMA**

Populate R351 for DPST implementation only.

Populate R346 for platform without DPST support. No Stuff for Discrete DSPT support due to back up plan.

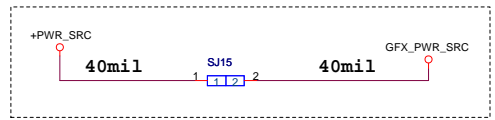
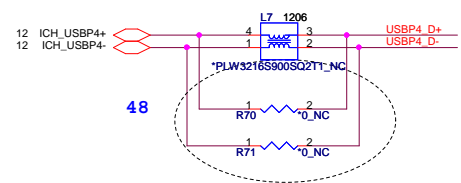

**QUANTA COMPUTER**

Title: LCD CONN & CK-SSCD

Size	Document Number VM9/VM8	Rev	1A
Date:	Wednesday, June 25, 2008	Sheet	18 of 53

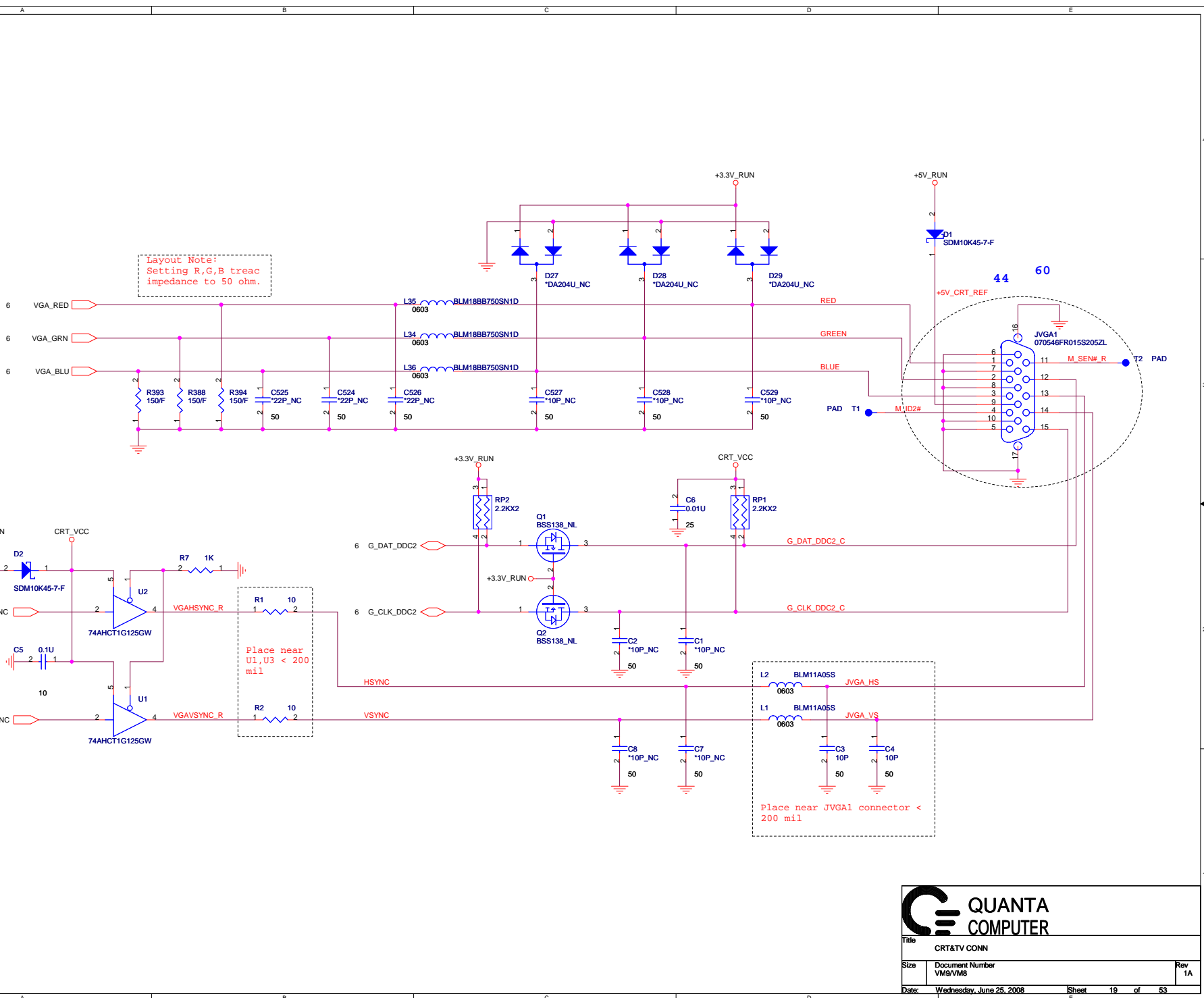

Layout Note:  
Setting R,G,B trace  
impedance to 50 ohm.

Place near  
U1,U3 < 200  
mil

Place near JVG A1 connector <  
200 mil

 <b>QUANTA COMPUTER</b>		
Size	Document Number VM9/VM8	Rev 1A
Date:	Wednesday, June 25, 2008	Sheet 19 of 53

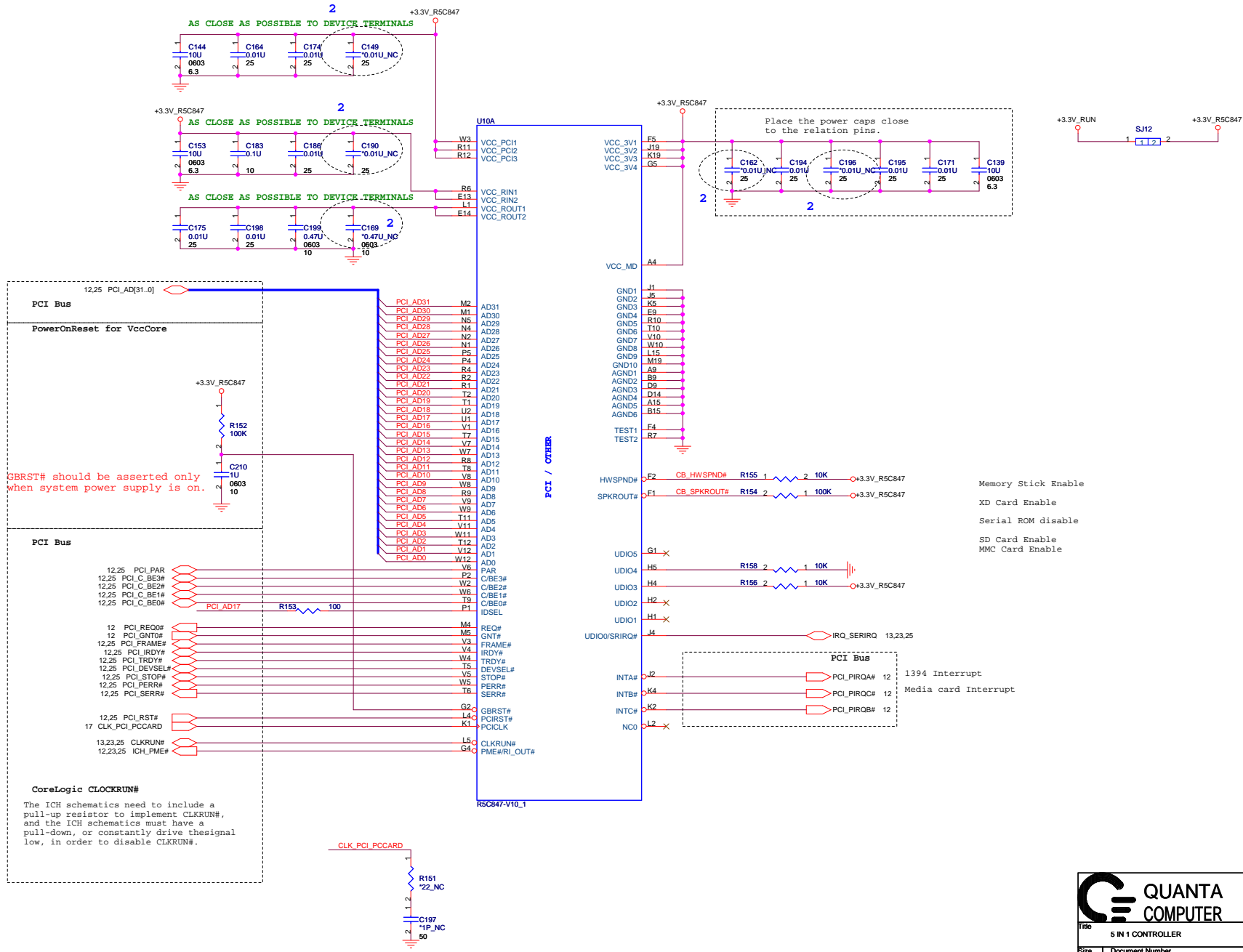

<b>QUANTA COMPUTER</b>		
File: 5 IN 1 CONTROLLER		
Size	Document Number	Rev
	VMS/VMB	1A
Date:	Wednesday, June 25, 2008	Sheet 20 of 53



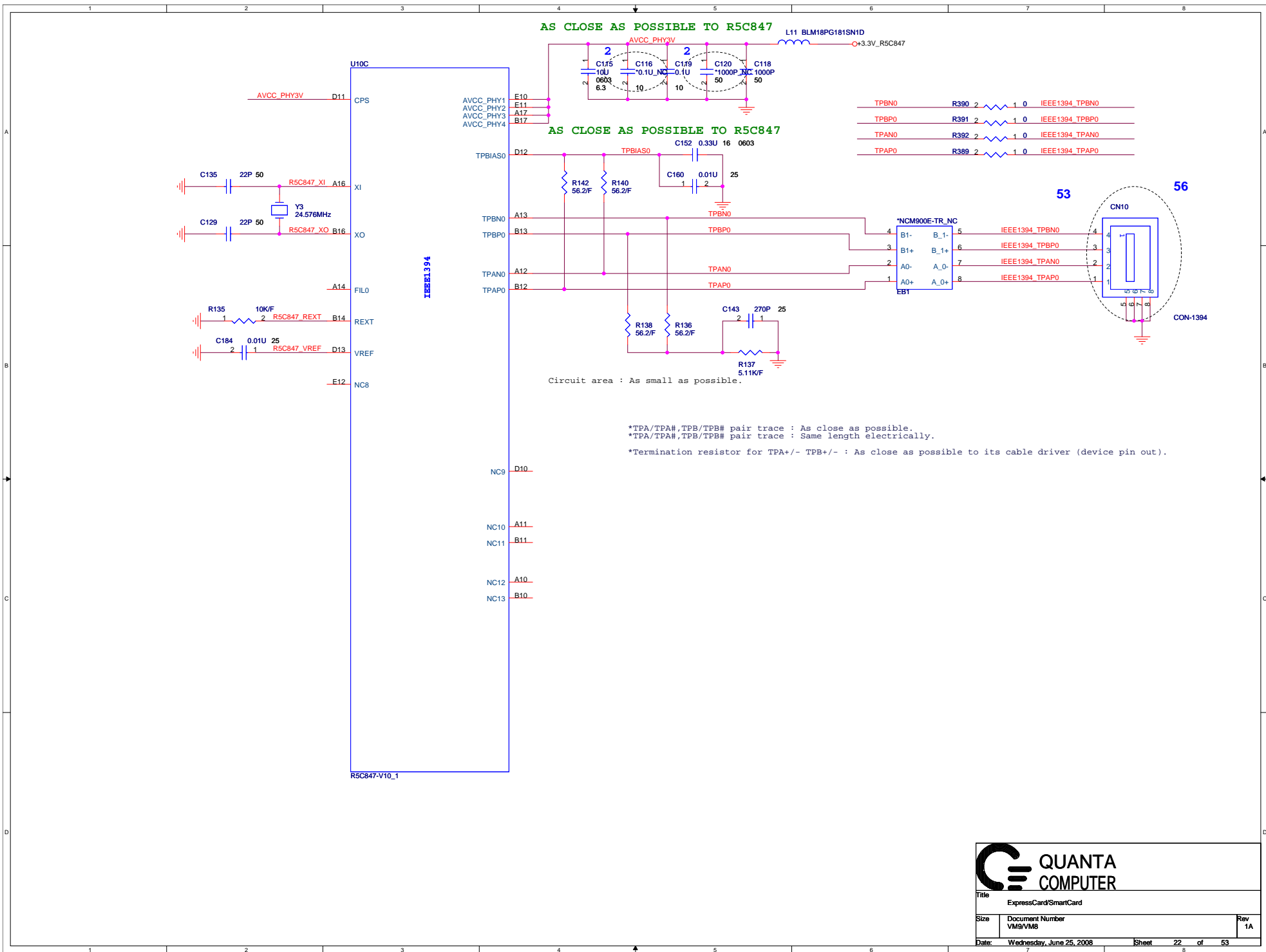

Title			ExpressCard/SmartCard
Size	Document Number	Rev	
	VM9/VM8	1A	
Date:	Wednesday, June 25, 2008	Sheet	22 of 53

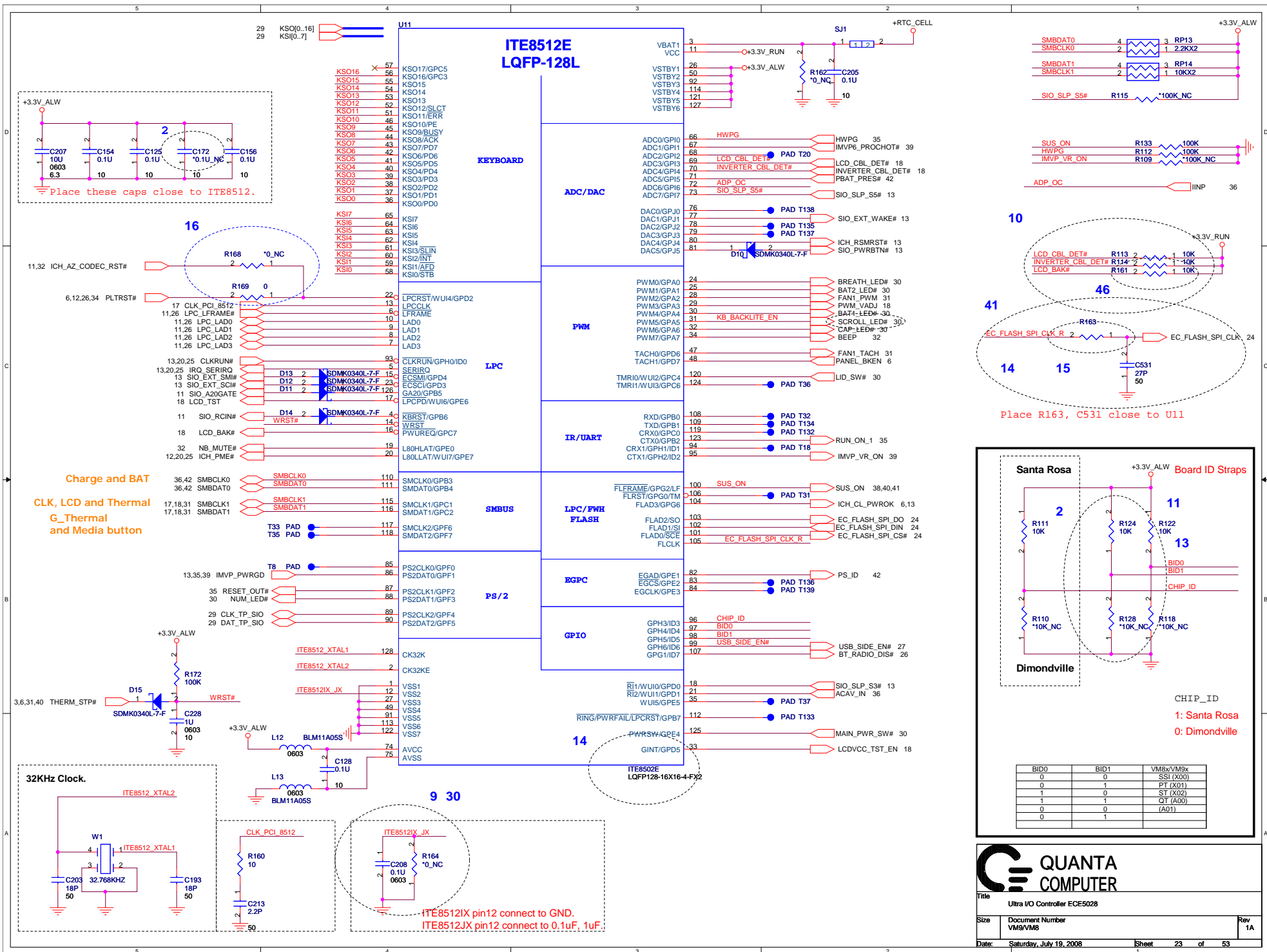

BID0	BID1	VM8x/VM9x
0	0	SSI (X00)
0	1	PT (X01)
1	0	ST (X02)
1	1	OT (A00)
0	0	(A01)
0	1	

**QUANTA COMPUTER**

Title: Ultra I/O Controller ECE5028

Size	Document Number VM9/VM8	Rev	1A
Date:	Saturday, July 19, 2008	Sheet	23 of 53

### 16Mbit (2M Byte), SPI

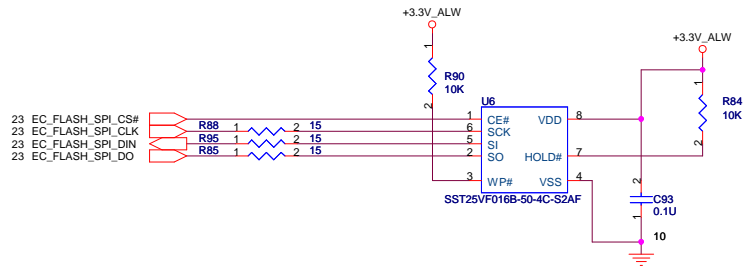

### RTC BATTERY

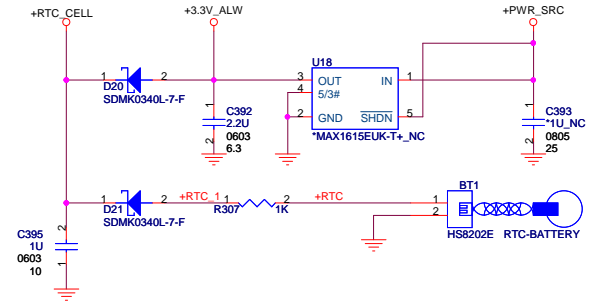

Title Ultra I/O Controller ECE5028

Size Document Number VM9/VM8

Rev 1A

Date: Wednesday, June 25, 2008

Sheet 24 of 53



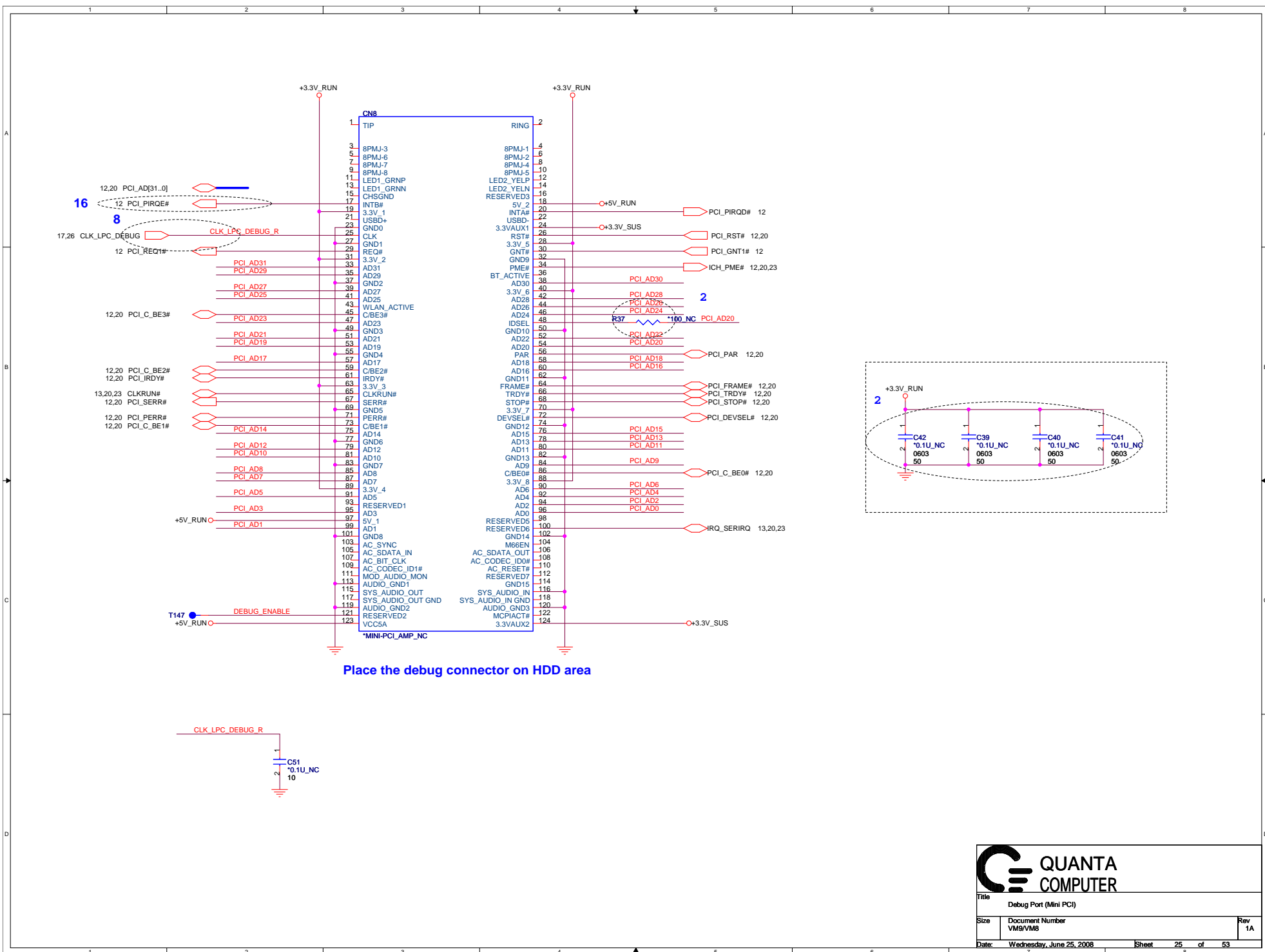

**QUANTA COMPUTER**

Title: Debug Port (Mini PCI)

Size	Document Number VM9/VM8	Rev 1A
------	-------------------------	--------

Date: Wednesday, June 25, 2008 Sheet 25 of 53

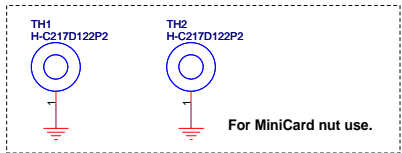

### MiniCard WLAN connector

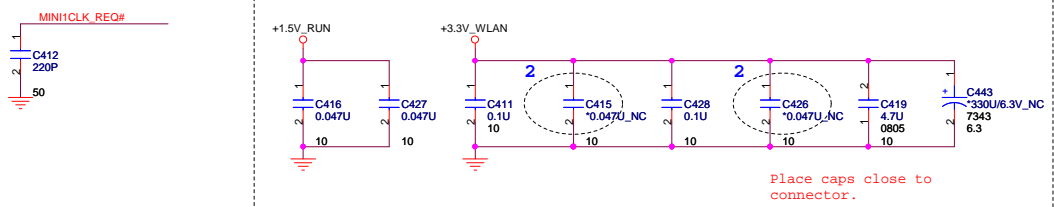
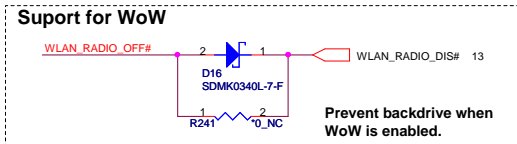
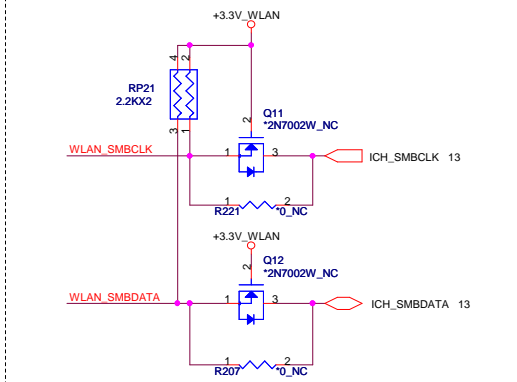
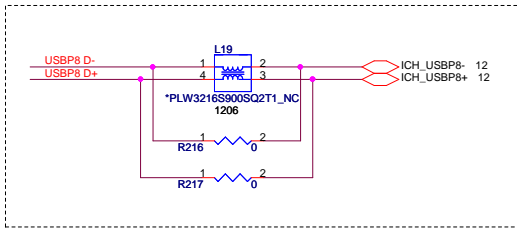
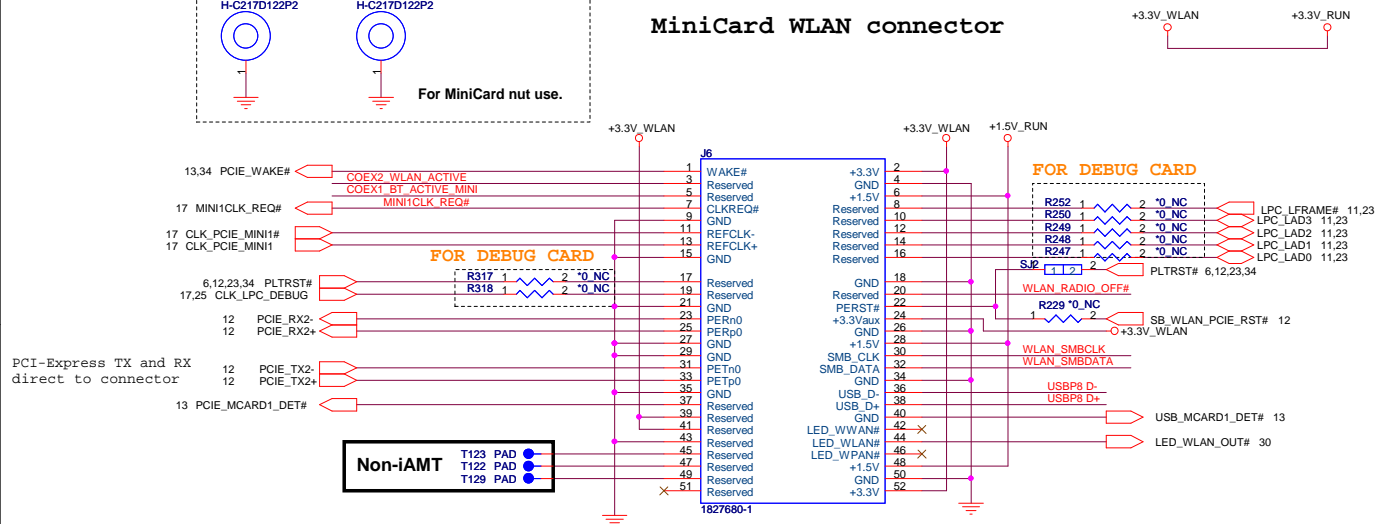

### Bluetooth

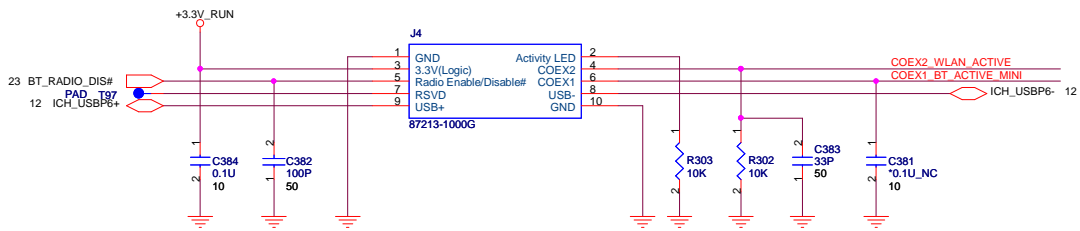

Title MDC CONN.			Rev 1A
Size	Document Number VM9/VMB		
Date: Wednesday, June 25, 2008	Sheet 26	of 53	

External USB PORT hookup reference. Your design may need more or less external ports and may be mapped differently

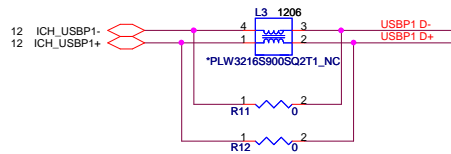
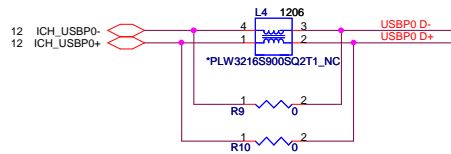

Platforms should put in PADS for the USB chokes if they have the room. Chokes should be NOPOP.

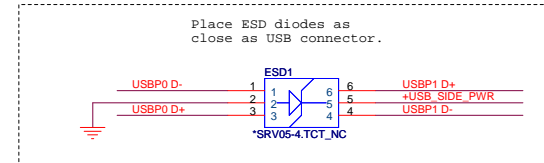
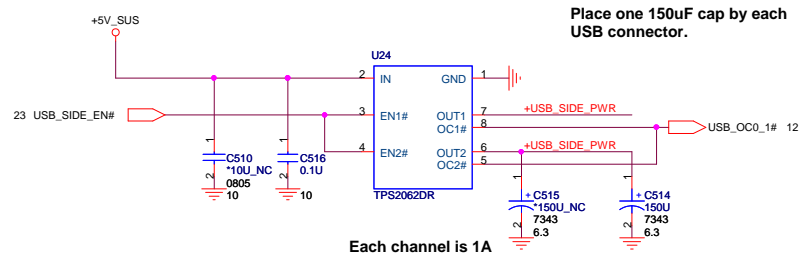
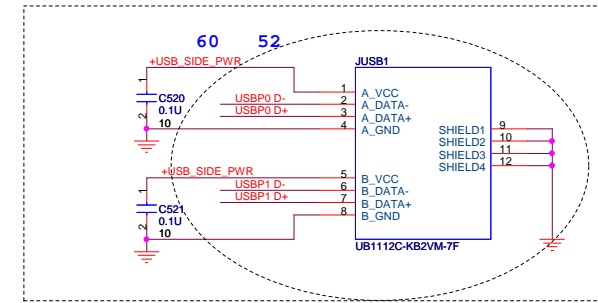

Title SERIAL PORT & USB			Rev 1A
Size	Document Number VM9/VM8		
Date: Wednesday, June 25, 2008	Sheet 27	of 53	

**SATA HDD Connector.**

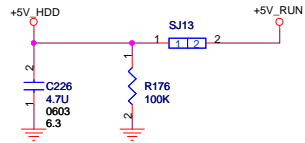
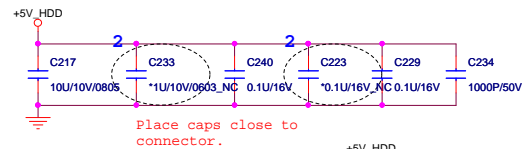
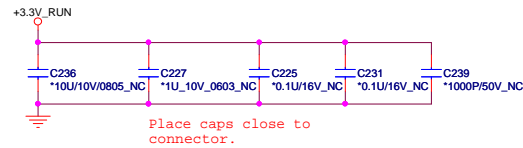
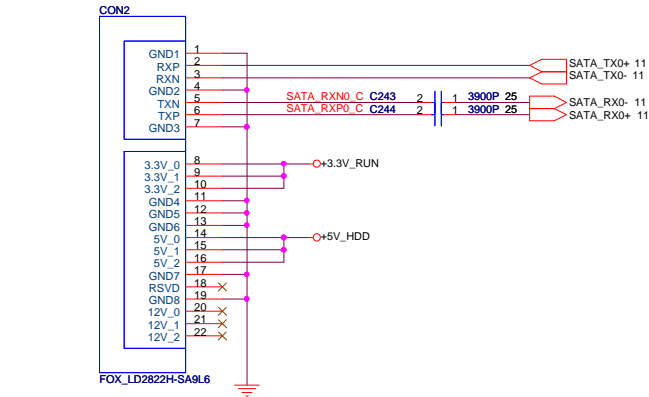

**SATA ODD Connector.**

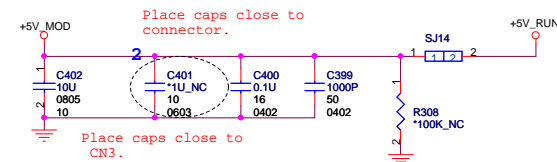
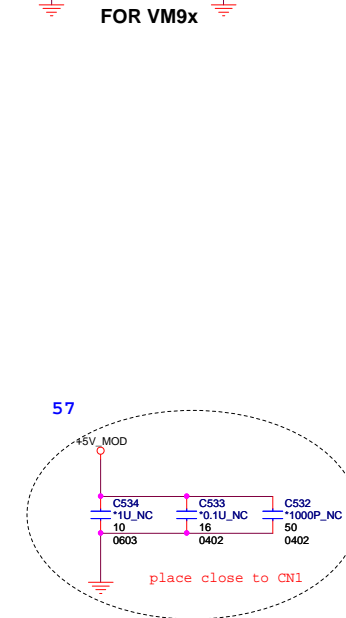
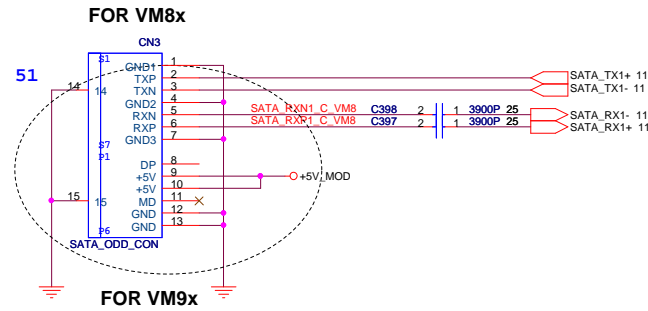

Title			SATA (HDD&CD_ROM)
Size	Document Number	Rev	
	VM9/VM8	1A	
Date:	Wednesday, June 25, 2008	Sheet	28 of 53

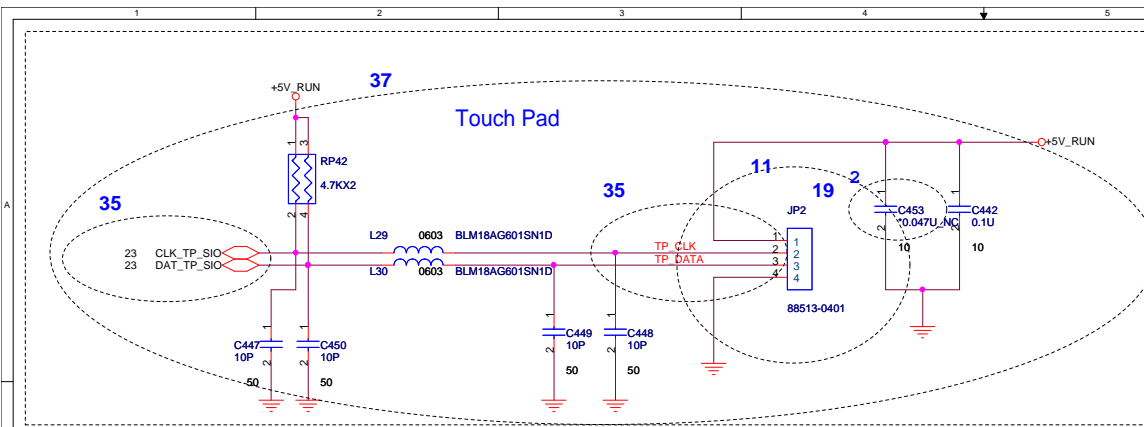

### KEYBOARD CONNECTOR

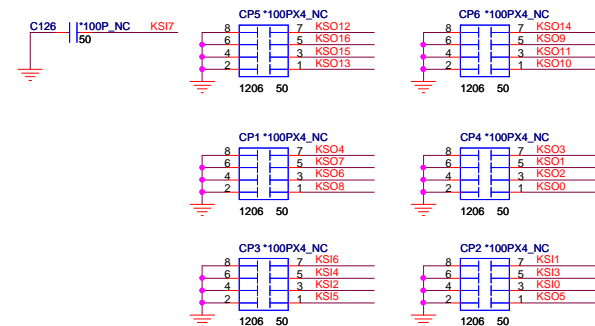
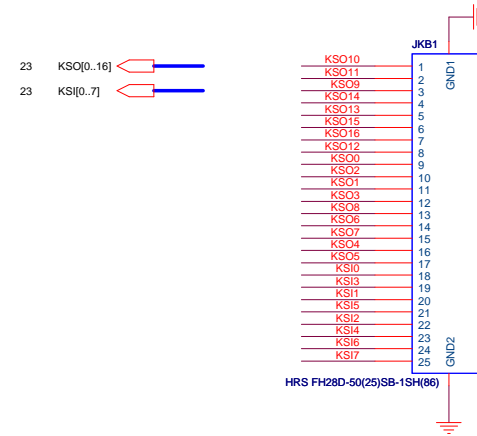

100P CAPS CLOSE TO JKB1

**QUANTA COMPUTER**

Title: TOUCH PAD, BULE TOOTH & FIR

Size	Document Number VM9/VM8	Rev 1A
Date:	Wednesday, June 25, 2008	Sheet 29 of 53

### Keyboard LED

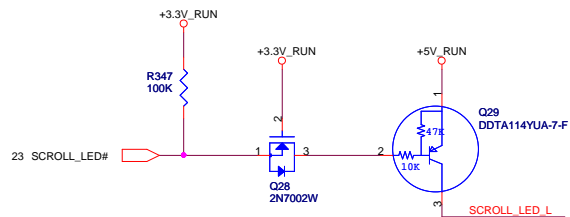
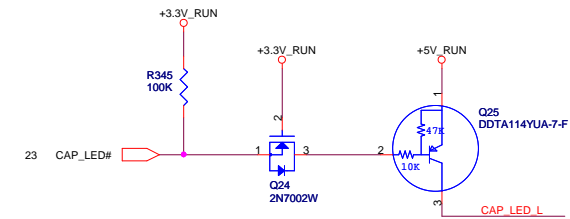
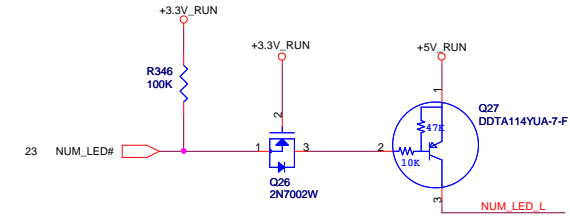

### HDD activity LED.

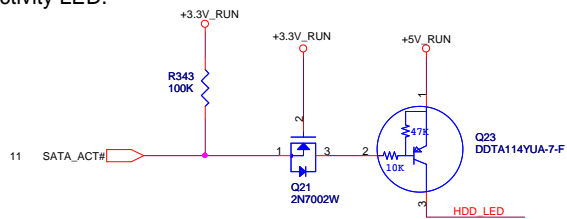

### Battery in charging

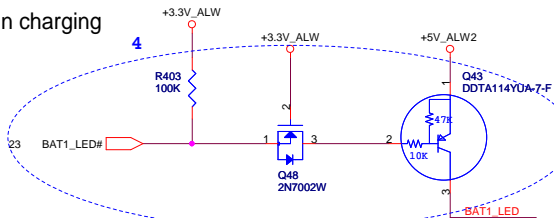

20

### Dash board connector

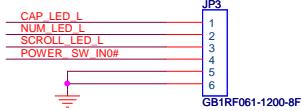

### WLAN

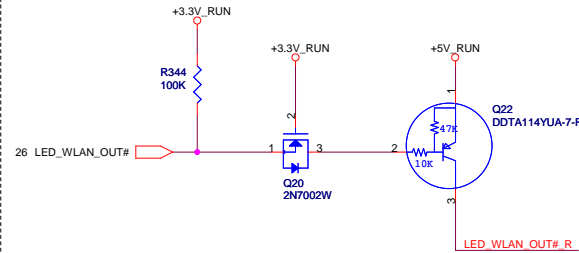

### Power & Suspend.

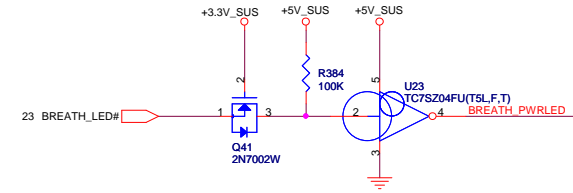

### Power Switch

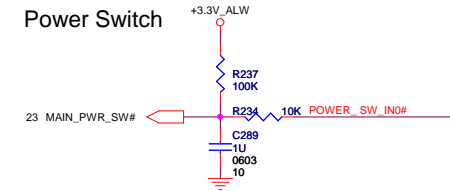

### LID Switch

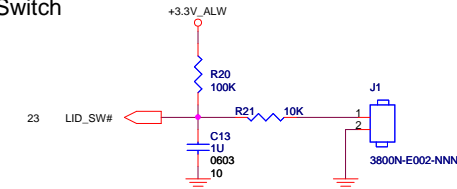

### Battery fault

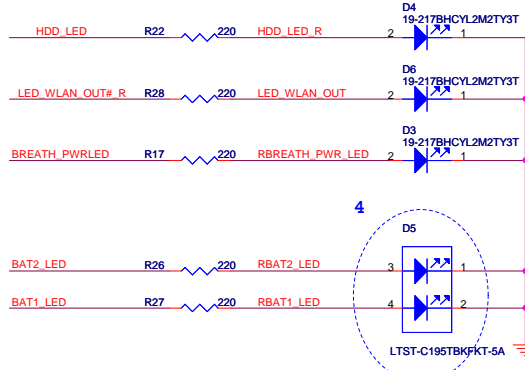
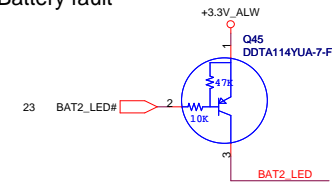

Title SWITCH, KEYBOARD & LED

Size Document Number VM9/VM8

Rev 1A

Date: Wednesday, June 25, 2008

Sheet 30 of 53

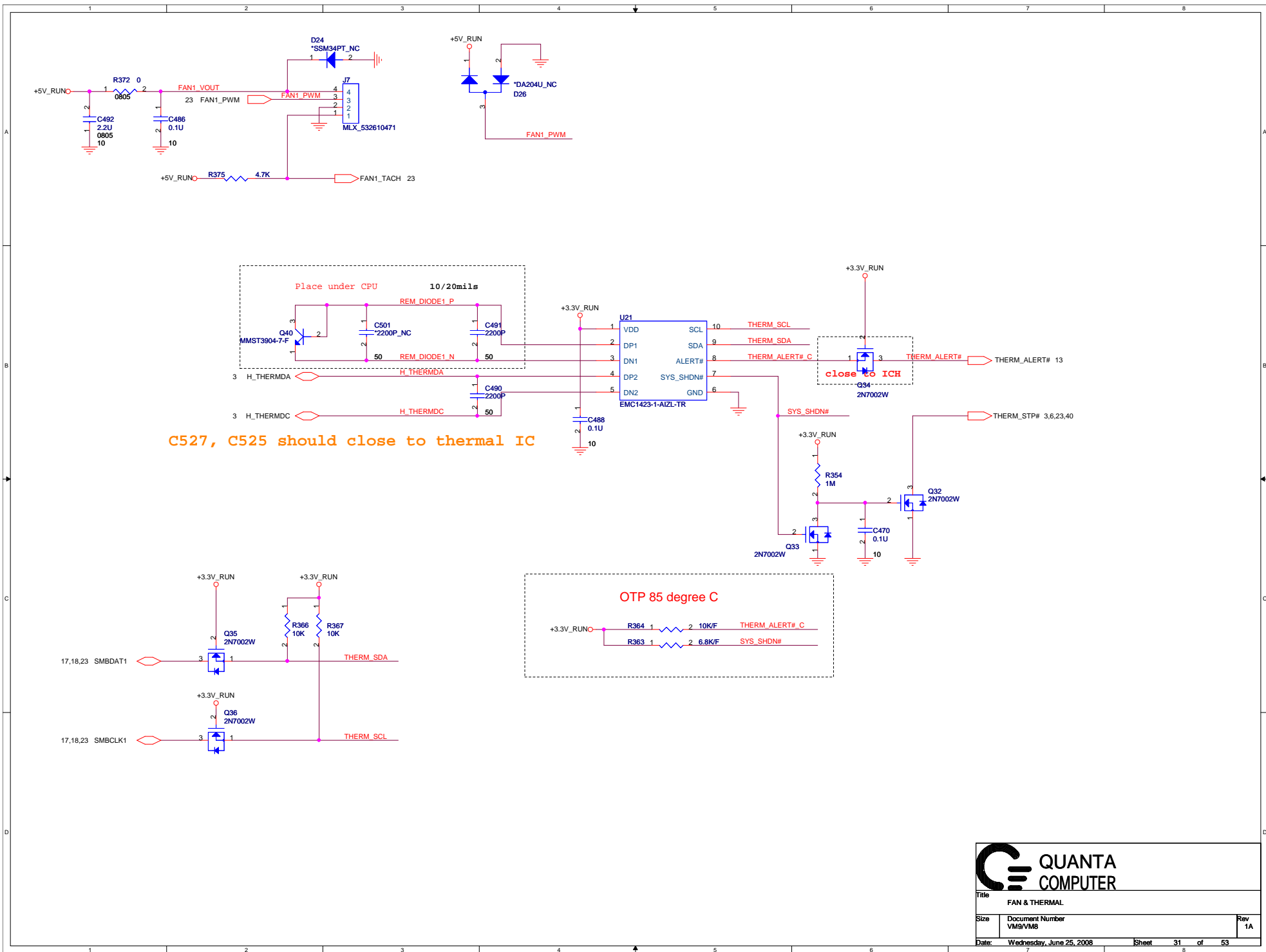

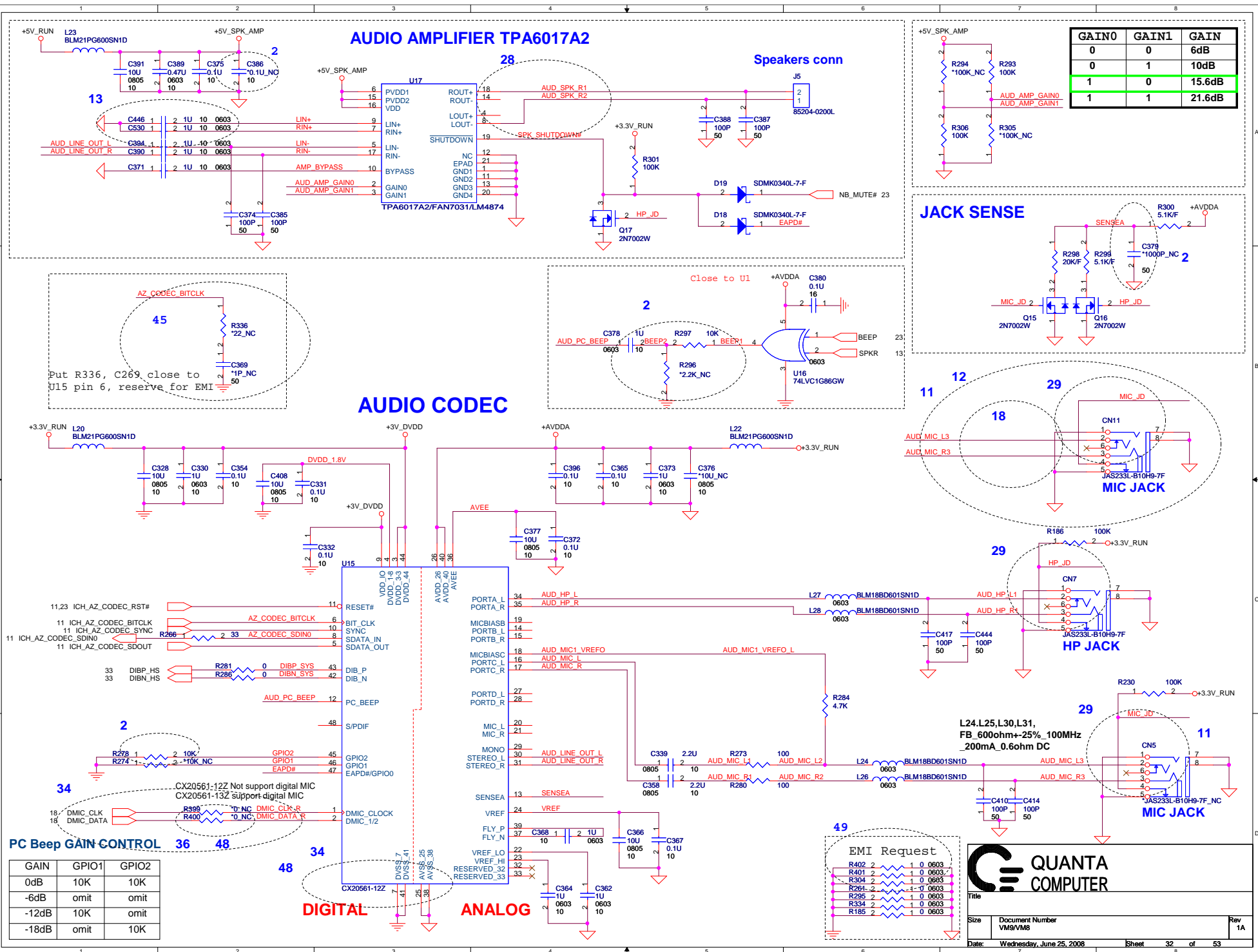

GAIN0	GAIN1	GAIN
0	0	6dB
0	1	10dB
1	0	15.6dB
1	1	21.6dB

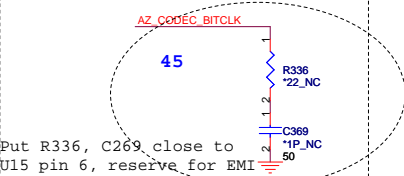

GAIN	GPIO1	GPIO2
0dB	10K	10K
-6dB	omit	omit
-12dB	10K	omit
-18dB	omit	10K

**QUANTA COMPUTER**

Title: \_\_\_\_\_

Size: \_\_\_\_\_ Document Number: VM9/VM8 Rev: 1A

Date: Wednesday, June 25, 2008 Sheet: 32 of 53



Revision History		
REV	Description	Date
0	Initial Release	April 26, 2005
4		

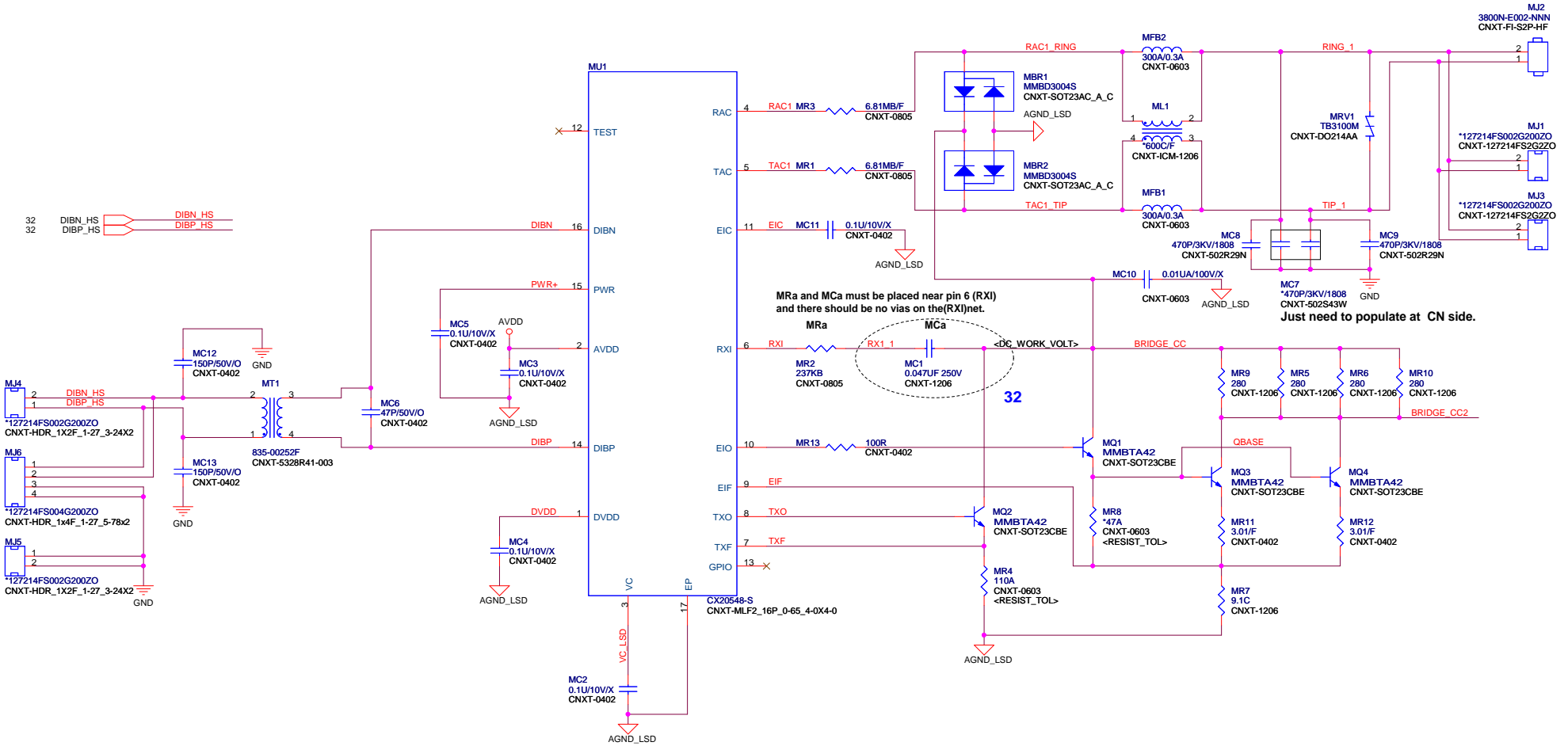

Title		
Size	Document Number	Rev
	VM9/VM8	1A
Date:	Wednesday, June 25, 2008	Sheet 33 of 53

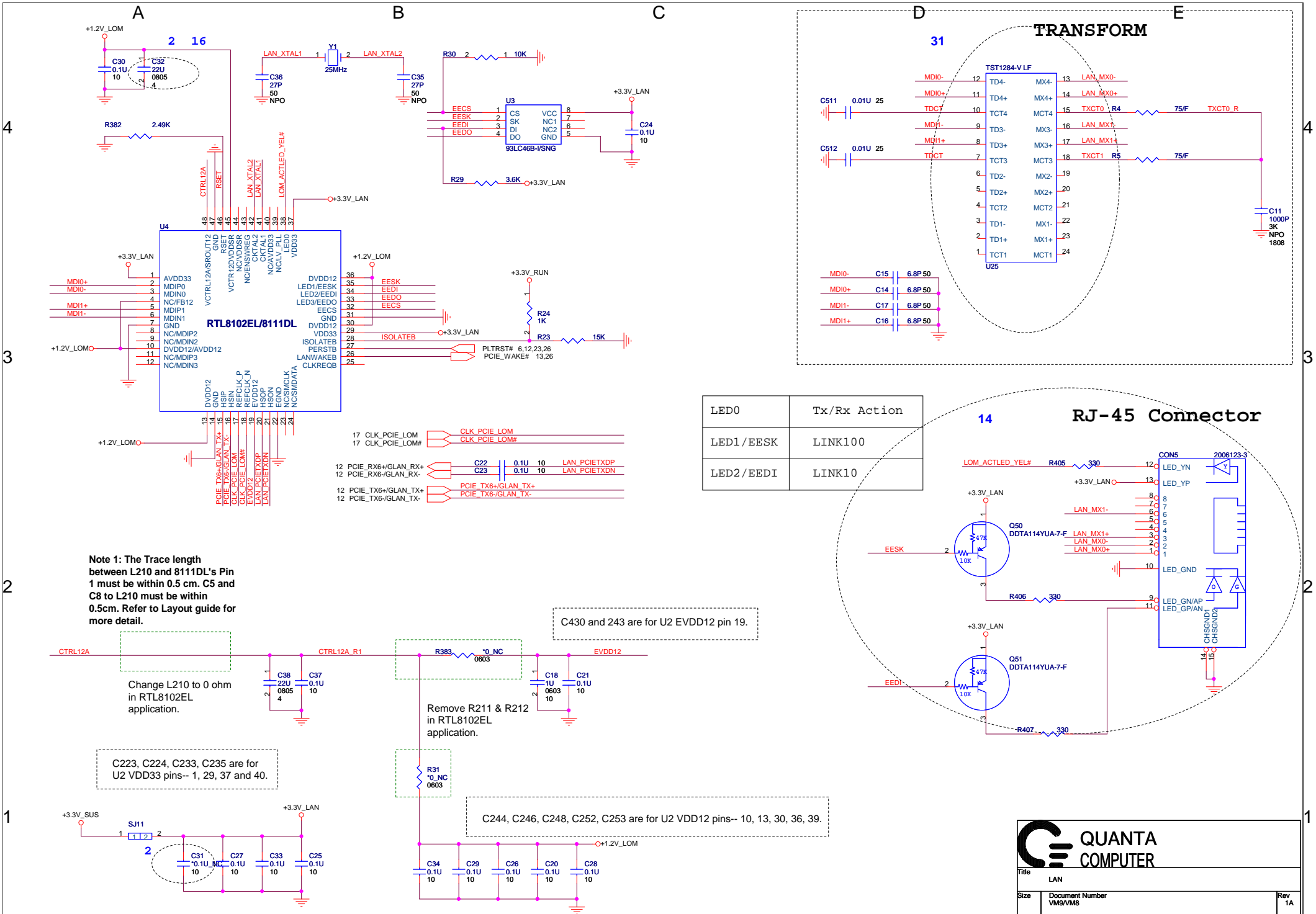

**QUANTA COMPUTER**

Title: LAN

Size: VM9/VM8 Document Number: VM9/VM8 Rev: 1A

Date: Saturday, July 19, 2008 Sheet: 34 of 53

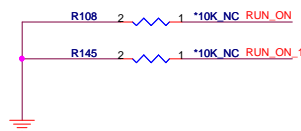
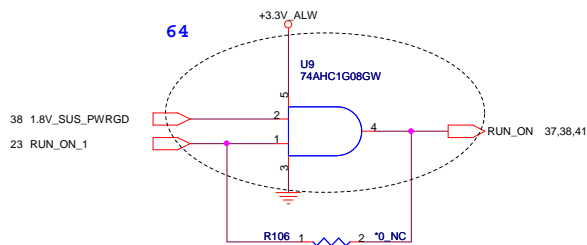
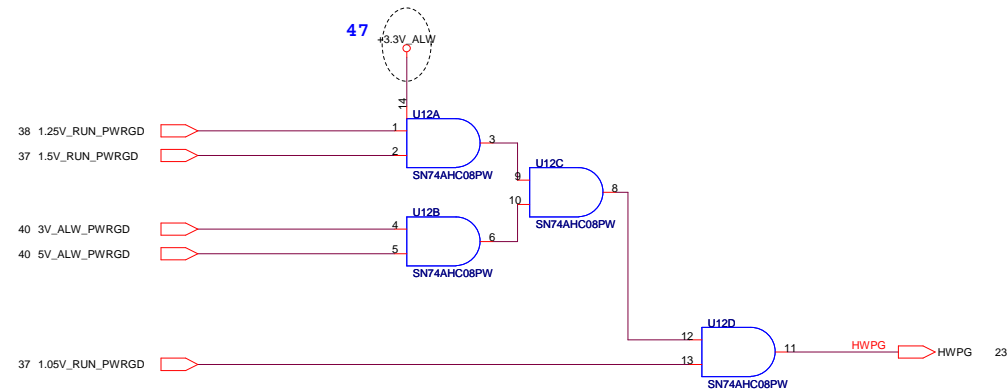
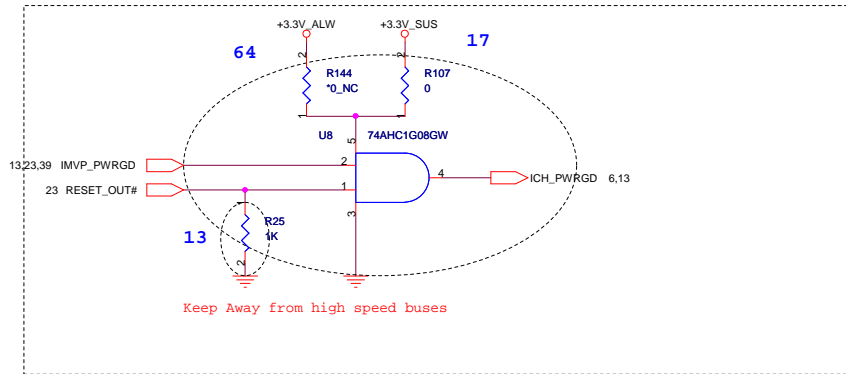

Title			System Reset Circuit
Size	Document Number	Rev	
	VM9/VM8	1A	
Date:	Friday, July 25, 2008	Sheet	35 of 53

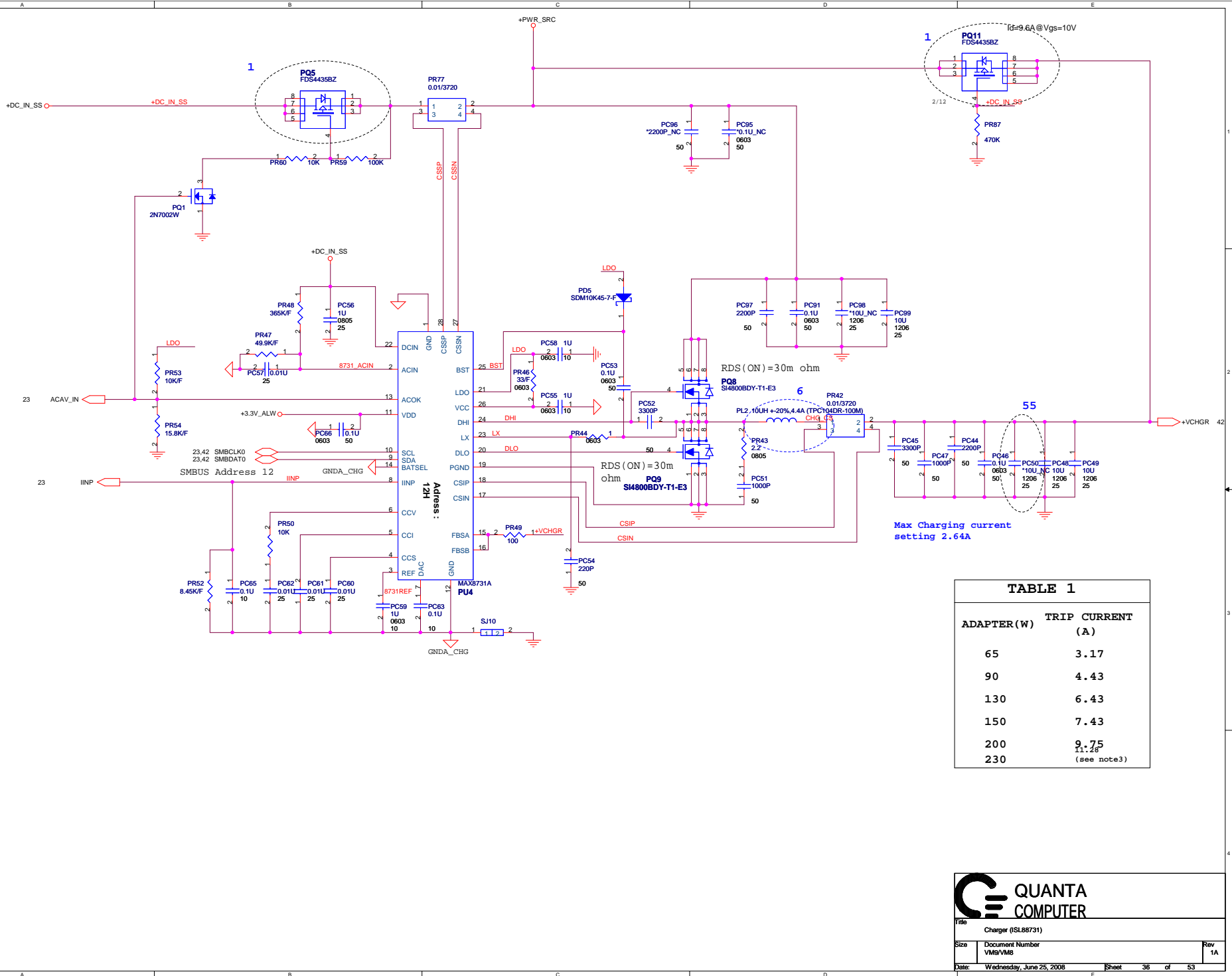

Max Charging current setting 2.64A

**TABLE 1**

ADAPTER (W)	TRIP CURRENT (A)
65	3.17
90	4.43
130	6.43
150	7.43
200	9.75
230	11.26 (see note3)

**QUANTA COMPUTER**

Title: Charger (SL88731)

Size: Document Number VMS/VMS Rev 1A

Date: Wednesday, June 25, 2008 Sheet 36 of 53

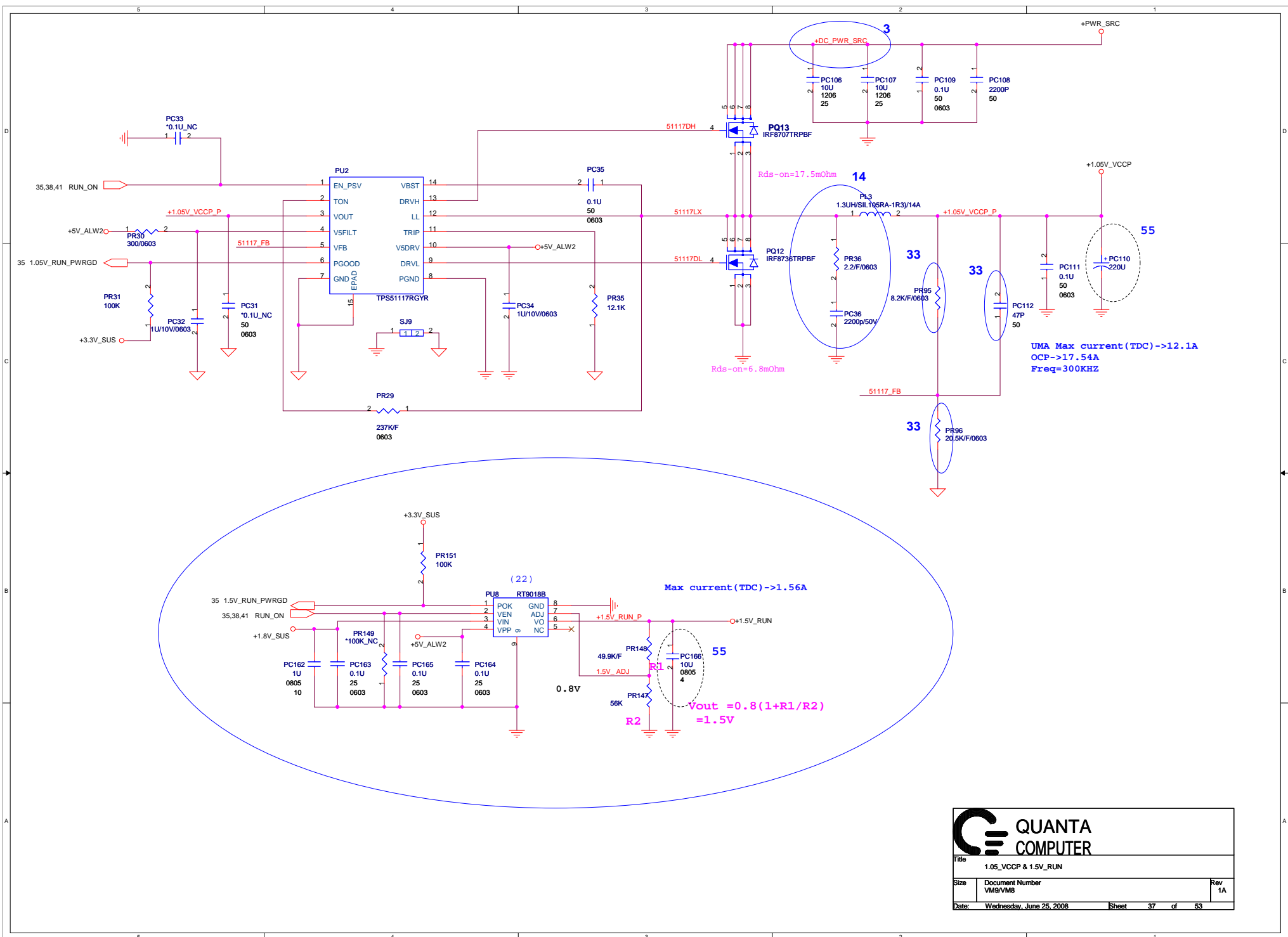

**QUANTA COMPUTER**

Title: 1.05_VCCP & 1.5V_RUN		
Size: VM9/VM8	Document Number: VM9/VM8	Rev: 1A
Date: Wednesday, June 25, 2008	Sheet: 37	of 53

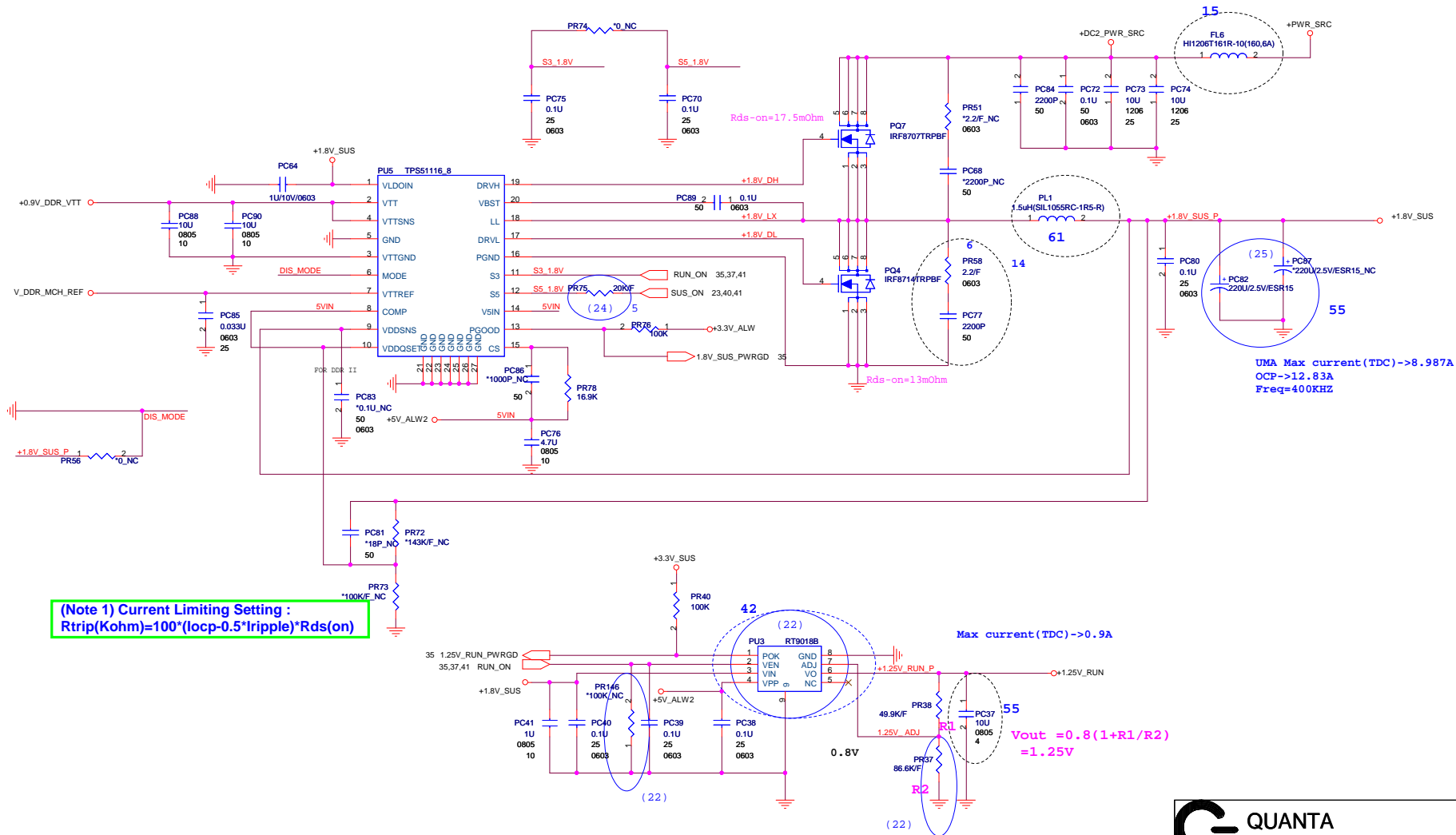

**(Note 1) Current Limiting Setting :**  
 $R_{trip}(Kohm) = 100 * (I_{ocp} - 0.5 * I_{tripple}) * R_{ds(on)}$

UMA Max current (TDC) -> 8.987A  
 OCP -> 12.83A  
 Freq = 400KHZ

Max current (TDC) -> 0.9A

$$V_{out} = 0.8 * (1 + R1/R2) = 1.25V$$

**QUANTA COMPUTER**

Title	1.8VSUS & 0.9VTT (TPS51116)		
Size	Document Number	Rev	
	VM9/VM8	1A	
Date:	Wednesday, June 25, 2008	Sheet	38 of 53







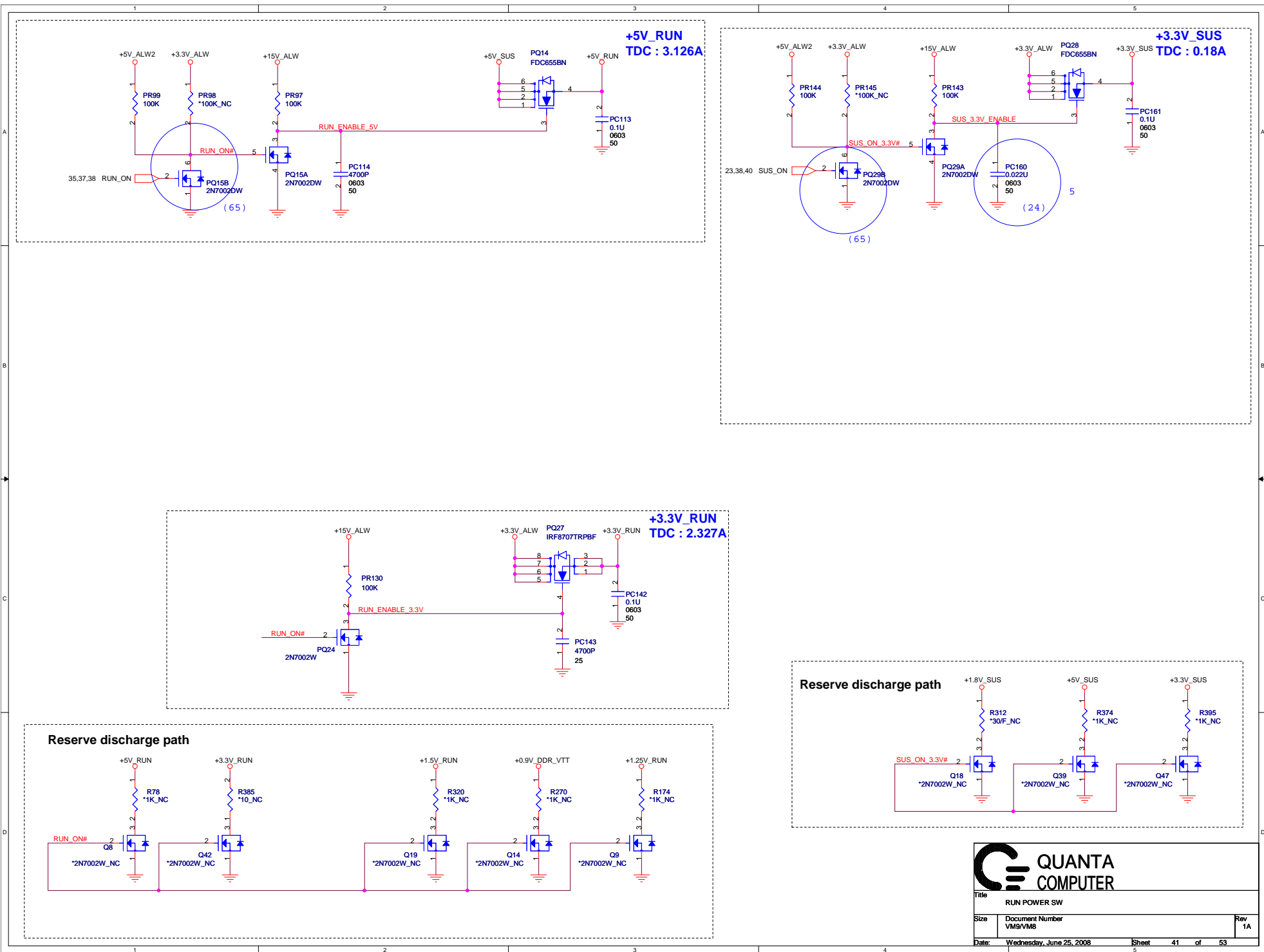

Title			Rev
RUN POWER SW			1A
Size	Document Number		
	VM9/VM8		
Date:	Wednesday, June 25, 2008	Sheet	41 of 53

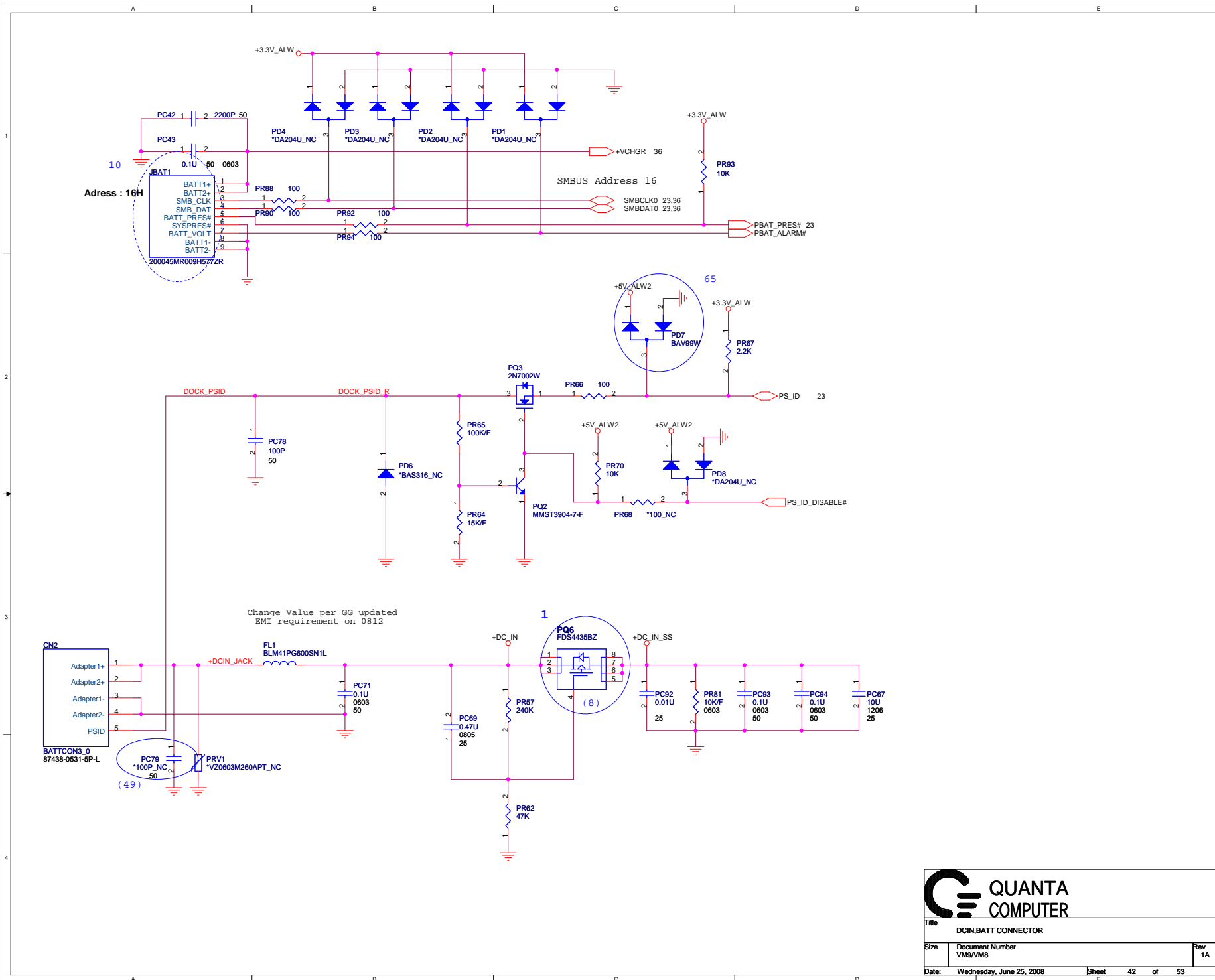

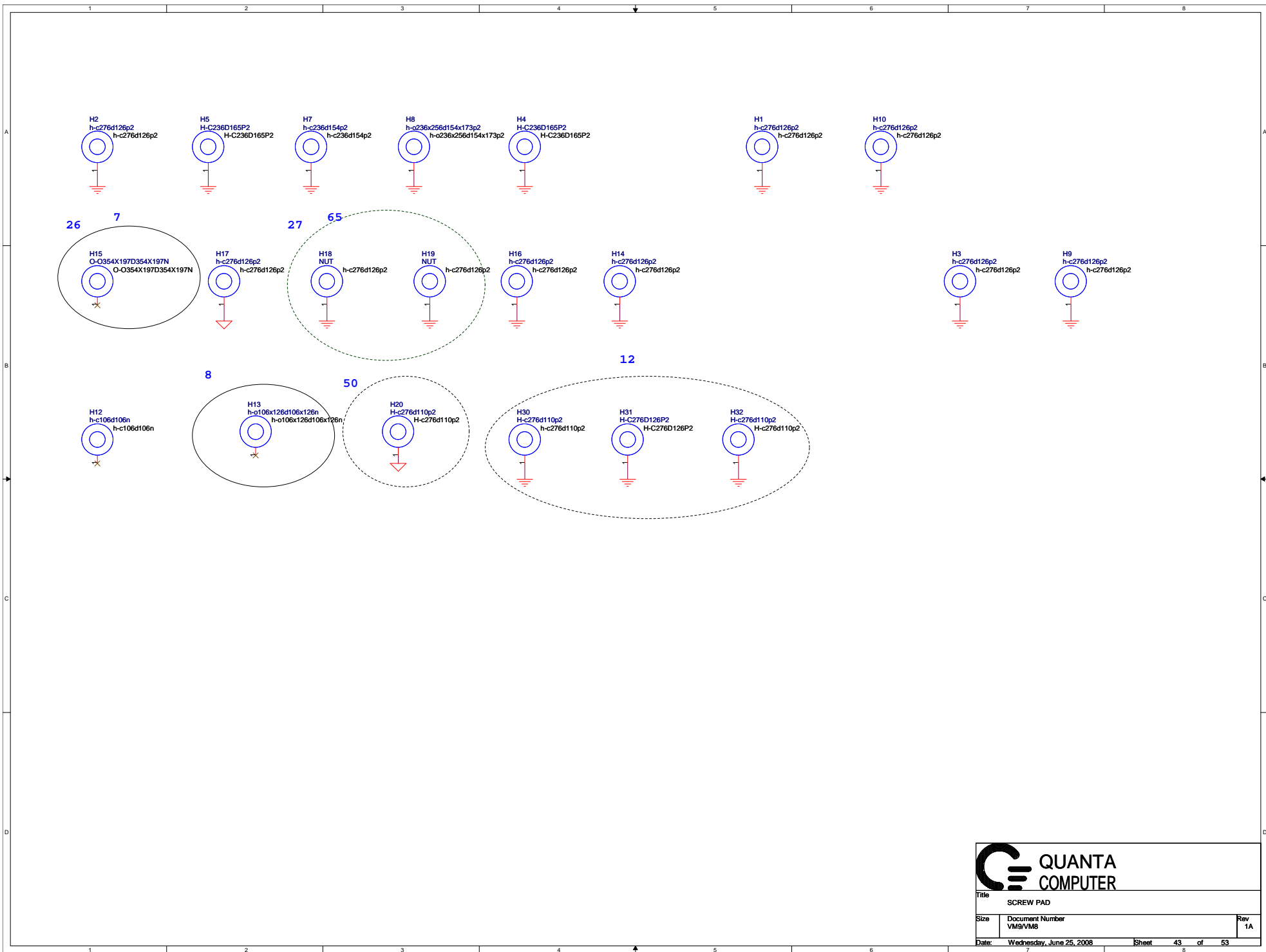

Reserved for EMI.

Stitching caps for PCI bus.

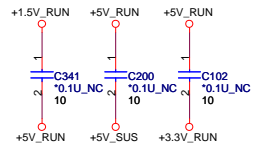

40  
Stitching caps for PCI EMC.

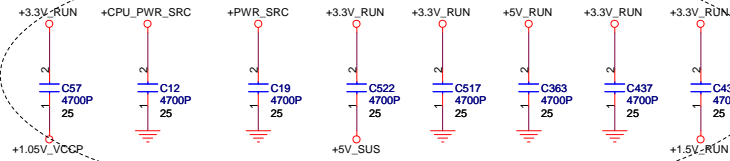

Title		EMI CAP	
Size	Document Number	Rev	
	VM9/VM8	1A	
Date:	Wednesday, June 25, 2008	Sheet	44 of 53

**ICH8-M**

**SIO  
ITE8512**

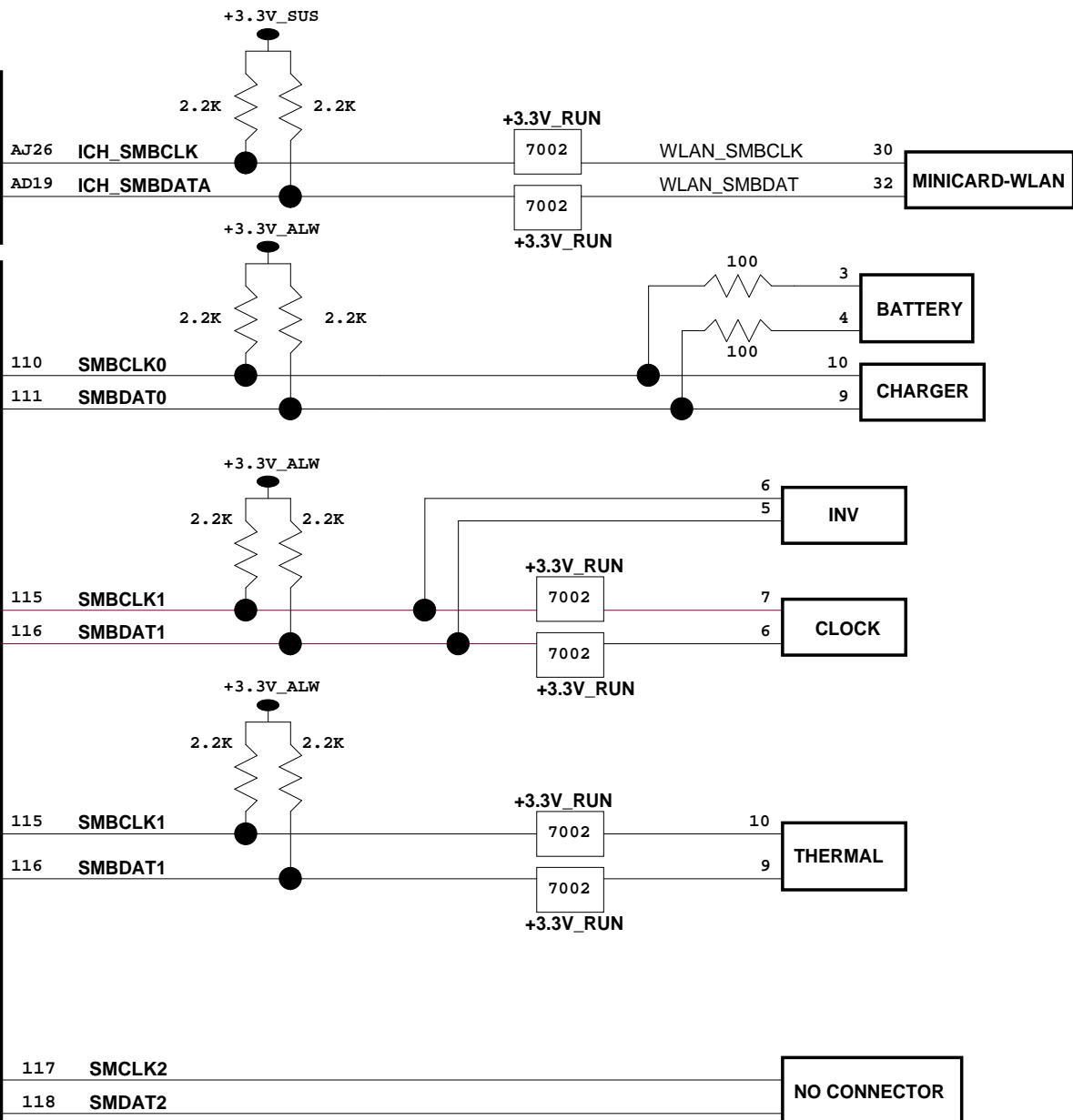

**QUANTA  
COMPUTER**

Title: SMBUS BLOCK

Size	Document Number VM9/VM8	Rev 1A
------	----------------------------	-----------

Date: Wednesday, June 25, 2008 Sheet 45 of 53

