

SAMSUNG

UMTS TELEPHONE

SGH-Z300

SERVICE *Manual*

UMTS TELEPHONE



CONTENTS

1. Specification
2. Circuit Description
3. Exploded Views and Parts List
4. Electrical Parts List
5. Block Diagrams
6. PCB Diagrams
7. Flow Chart of Troubleshooting

**SAMSUNG
ELECTRONICS**



This Service Manual is a property of Samsung Electronics Co.,Ltd.
Any unauthorized use of Manual can be punished under applicable
international and/or domestic law.

Samsung Electronics Co.,Ltd. June. 2005
Printed in Korea.

Code No.: GH68-07501A
BASIC.

1. Specification

1-1. GSM General Specification

	EGSM 900	DCS1800	PCS1900	W-CDMA
Freq. Band[MHz] Uplink/Downlink	880~915 925~960	1710~1785 1805~1880	1850~1910 1930~1990	1920~1980 2110~2170
ARFCN range	0~124 & 975~1023	512~885	512~810	UL:9612~9888 DL:10562~10838
Tx/Rx spacing	45MHz	95MHz	80MHz	190MHz
Mod. Bit rate/ Bit Period	270.833kbps 3.692us	270.833kbps 3.692us	270.833kbps 3.692us	3.84Mcps
Time Slot Period/Frame Period	576.9us 4.615ms	576.9us 4.615ms	576.9us 4.615ms	Frame length : 10ms Slot length : 0.667ms
Modulation	0.3GMSK	0.3GMSK	0.3GMSK	QPSK HQPSK
MS Power	33dBm~5dBm	30dBm~0dBm	30dBm~0dBm	24dBm ~ - 50dBm
Power Class	4 (max +33dBm)	1 (max +30dBm)	1 (max +30dBm)	3 (max +24dBm)
Sensitivity	-102dBm	-100dBm	-100dBm	-106.7dBm
TDMA Mux	8	8	8	
Cell Radius	35Km	2Km	2Km	2Km

1-2. GSM TX power class

TX Power control level	GSM900	TX Power control level	DCS1800	TX Power control level	PCS1900
5	33±2 dBm	0	30±3 dBm	0	30±3 dBm
6	31±2 dBm	1	28±3 dBm	1	28±3 dBm
7	29±2 dBm	2	26±3 dBm	2	26±3 dBm
8	27±2 dBm	3	24±3 dBm	3	24±3 dBm
9	25±2 dBm	4	22±3 dBm	4	22±3 dBm
10	23±2 dBm	5	20±3 dBm	5	20±3 dBm
11	21±2 dBm	6	18±3 dBm	6	18±3 dBm
12	19±2 dBm	7	16±3 dBm	7	16±3 dBm
13	17±2 dBm	8	14±3 dBm	8	14±3 dBm
14	15±2 dBm	9	12±4 dBm	9	12±4 dBm
15	13±2 dBm	10	10±4 dBm	10	10±4 dBm
16	11±3 dBm	11	8±4dBm	11	8±4dBm
17	9±3dBm	12	6±4 dBm	12	6±4 dBm
18	7±3 dBm	13	4±4 dBm	13	4±4 dBm
19	5±3 dBm	14	2±5 dBm	14	2±5 dBm
		15	0±5 dBm	15	0±5 dBm

2. Circuit Description

2-1. SGH-Z300 RF Circuit Description

- Antenna Switch Module (U600)

The antenna switch module allows multiple operating bands and modes to share the same antenna. A common antenna connects to one of five paths: 1) UMTS-2100 Rx/Tx, 2) EGSM-900 Rx, 3) EGSM-900 Tx, 4) DCS-1800 Rx, and 5) DCS-1800 Tx. 6) PCS-1900 Tx, 7) PCS-1900 Rx, UMTS operation requires simultaneous reception and transmission.

- Filter

To convert Electromagnetic Field Wave to Acoustic Wave and then pass the specific frequency band.

- GSM Rx FILTER (F601) For filtering the frequency band between 925 ~ 960 MHz.

- DCS Rx FILTER (F602) For filtering the frequency band 1805 and 1880 MHz.

- DCS Rx FILTER (F603) For filtering the frequency band 1930 and 1990 MHz.

- WCDMA Rx FILTER (F701) For filtering the frequency band 2110 and 2170 MHz.

- WCDMA Tx FILTER (F703) For filtering the frequency band 1920 and 1980 MHz.

- VCTCXO (OSC701)

To generate the 19.2MHz reference clock to drive the logic and RF.

- Duplexer (F202)

A duplexer splits a single operating band into receive and transmit paths.

- UMTS PAM (U701)

This is a key component in the transmitter chain and must complement the RTR6250 IC precisely; jointly they dominate the UMTS transmitter performance characteristics. Parameters such as gain, output power level, ACLR, harmonics, Rx-band noise, and power supply current are critical.

- GSM/DCS/PCS PAM (U603)

The PAM is a key component in any transmitter chain and must complement the rest of the transmitter precisely. For GSM,DCS,PCS operation, the closed-loop transmit power control functions add even more requirements relative to the UMTS PA. In addition to gain control and switching requirements, the usual RF parameters such as gain, output power level, several output spectrum requirements, and power supply current are critical.

- GSM/DCS/PCS I Tx VCO (U601)

The Tx VCO outputs for EGSM, DCS, PCS drive a resistive network that splits the active signal into two signals: 1) the input to the active PAM ? this is the low loss path, and 2) the OPLL feedback signal.

- RF VCO (OSC702)

The single-band UHF VCO is a key component within its phase-locked loop; VCO performance directly impacts PLL and transceiver performance. UMTS Rx LO signal is generated from this VCO's output.

- RFL6200 (U702)

The RFL6200 includes an LNA circuit optimized for UMTS-2100 operation. The LNA is separated from all other receive functions contained within the RFR6200 receiver IC to improve mixer LO to RF isolation ? a critical parameter in the Zero-IF architecture.

- RFR6200 (U703)

The RFR6200 provides the Zero-IF receiver signal path, from RF to analog baseband, for UMTS-2100 applications. The RFR6200 accepts its UMTS input signal from the handset RF front-end design. The UMTS input is configured differentially to optimize second-order inter-modulation and common mode rejection performance, and implements MSM-controlled gain adjustments to extend the receiver dynamic range.

- RTR6250 (U602)

The RTR6250 supports multi-band, multi-mode phones with two receiver signal paths and three transmitter signal paths:

Receiver paths

- EGSM-900
- DCS-1800
- PCS-1900

Transmitter paths

- EGSM-900 (using OPLL technique)
- DCS-1800 (using OPLL technique)
- PCS-1900
- UMTS-2100

Numerous secondary functions are integrated on-chip as well:

2-2. Baseband Circuit description of SGH-Z300

2-2-1. PM6650

- Power Management

Ten low-dropout regulators designed specifically for GSM applications power the terminal and help ensure optimal system performance and long battery life. It provides LDOs support for 1.375V, 1.8V, 2.6V, 2.85V, 3.3V.

IC-level interfaces include the three-line serial bus interface(SBI) used by the MSM6250 device to control and status the PM6650 IC.

- Keypad Backlight

The Keypad backlight driver output is at pin 23 (KYPD_BACKLIGHT_DRV) and is designed to drive parallel connected LEDs directly. Its output current level is SBI-programmable and meets the performance specified below. Input parameters are not specified since they are internal.

- TCXO Controller and Buffers

The PM6650 IC includes circuits for controlling the TCXO warm-up and buffering its signal for distribution throughout the handset. Performance specifications are presented below.

2-2-2. Connector

- LCD Connector

LCD is consisted of main LCD(color 262K TFT LCD) and small LCD(OLED color 65K LCD). Chip select signals in the U300, MAIN_LCD_CS can enable main LCD and SUB_LCD_CS can enable small LCD. CAM_PWR_ON signal enables white LED of main LCD. MAIN_LCD_RESET signal initiates the reset process of the main LCD. SUB_LCD_RESET signal initiates the Reset process of the small LCD.

16-bit data lines(D2(0)~D(15)) transfers data and commands to LCD. Data and commands use "RS" signal.

If this signal is high, Inputs to LCD are commands. If it is low, Inputs to LCD are data. The signal which informs the input or output state to LCD, is required. But this system is not necessary this signal.

Power signals for LCD are "VBATT_LCD". "SPKP_RCVP" and "SPKP_RCVN" from HEA401 are used for audio speaker. And "MOTOR_EN" from U100 enables the motor.

- Key

This is consisted of key interface pins among U100, KEYSENSE_N(0:4). These signals compose the matrix.

Result of matrix informs the key status to key interface in the U100. Power on/off key is seperated from the matrix. The key LED use the "VBATT" supply voltage. "KEY_LED" signal enables LEDs with current control.

"HALL_SW" informs the status of folder (open or closed) to the. This uses the hall effect IC, A3212ELH.

- EMI ESD Filter

This system uses the EMI ESD filter, GMF05LC to protect noise from IF CONNECTOR part.

- IF connector

It is 24-pin connector. They are designed to use VBATT, CF, UART1_TX, UART1_RX, UART1_RFR, UART1_CTS, JIG_ON, RTCK, TCK, TDI, TDO, TMS and GND. They connected to power supply IC, microprocessor and signal processor IC.

2-2-3. Audio

EAR1OP and EAR1ON from U100 are connected to the main speaker. AUXOP and AUXON are connected to the Digital AMP. MIC1P and MIC1N are connected to the main MIC. And MIC2P and MIC2N are connected to the Earphone.

YMU769 has a built-in amplifier, and thus, is an ideal device for outputting sounds that are used by mobile phones in addition to game sounds and ringing melodies that are replayed by a synthesizer.

The synthesizer section adopts "stereophonic hybrid synthesizer system" that are given advantages of both FM synthesizers and Wave Table synthesizers to allow simultaneous generation of up to 32 FM voices and 32 Wave Table voices. Furthermore, YMU769 has a built-in hardware sequencer that helps to realize complex play without heavily loading the host CPU. And this device also has a built-in circuit for controlling vibrators and LEDs synchronizing with play of music. The consumed electric current can be stopped to the minimum by power down mode when not operating.

The hardware sequence built in this device allows playing of the complex music without giving excessive load to the CPU of the portable telephones. Moreover, the registers of the FM synthesizer can be operated directly for real time sound generation, allowing, for example, utilization of various sound effects when using the game software installed in the portable telephone.

2-2-4. Memory

The signals in the MSM6250 enable two memories. They use only one volt supply voltage, VDD_LP from the PM6650. This system uses SEC's memory, KBE00F005M-F411. It is consisted of 1G bits flash NAND memory and 512M bits SDRAM memory. It has 16 bit data line, D1[0~15] which is connected to MSM6250. It has 22 bit address lines, A[1~22]. ROM_CS and RAM_CS signals is chip select.

2-2-5. Camera

The camera module consists of Mega pixel and VGA pixel. The Mega camera is a highly integrated CMOS color image sensor implemented by Hynix COMS sensor process realizing high sensitivity and wide dynamic range.

Total pixel array size is 1184H x 914V, and 1170H x 880V pixels are active. The VGA camera is a highly integrated CMOS color image sensor implemented by Hynix COMS sensor process realizing high sensitivity and wide dynamic range. Total pixel array size is 656H x 492V, and 656H x 488V pixels are active.

2-2-6. Irda

This system uses IRDA module, HSDL_3208, Agilent's. This has signals, "IRA_DOWN"(enable signal), "RXD0"(Input data) and "TXD0"(output data). These signals are connected to U100(MSN6250). It uses two power signals. "VDD_LP" is used for circuit and "VBATT" is used for LED.

3. Exploded View and Parts List

3-1. Exploded View

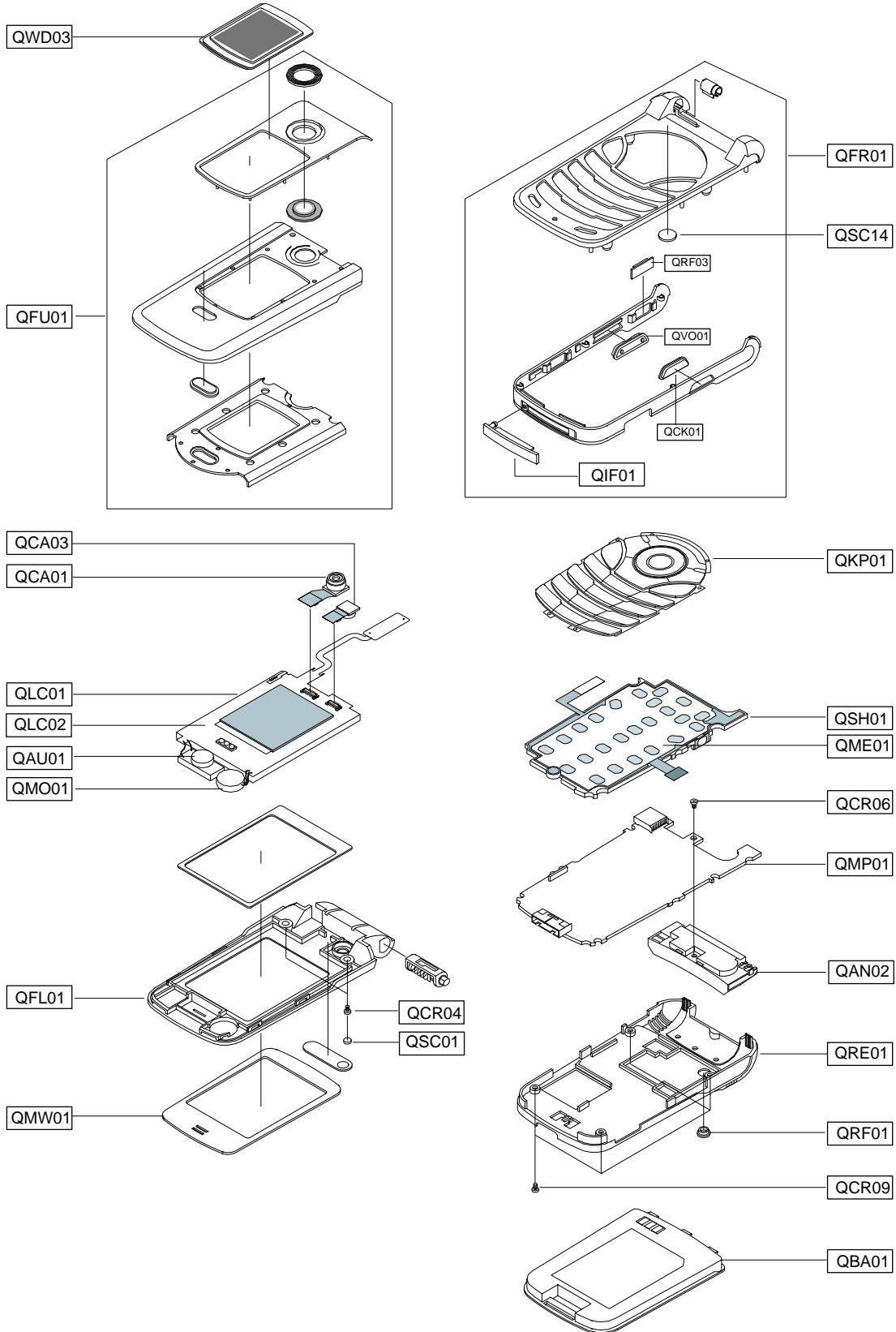

3-2. Parts List

Location NO.		Description	SEC CODE
QAN02		INTENNA-SGHZ300;H90-OY354,SGH-Z300,8	GH42-00563A
QAU01		AUDIO-RECEIVER; 32ohm,110dB,8X16mm	3009-001111
QBA01		BATTERY-BATTERY-960MAH,DA SI;BST4309	GH43-01789A
QCA01		UNIT-CAMERA;SGH-Z300,MOMFA140U1A,-,E	GH59-02027A
QCA03		UNIT-CAMERA;SGH-Z300,MOMFA240U1A,-,E	GH59-02028A
QCR04		SCREW-MACHINE;PH,+,M1.4,L4,NYLOK,SWR	6001-001479
QCR06		SCREW-MACHINE;PH(PI2.5),+,M1.4,L3.5,	6001-001155
QCR09		SCREW-MACHINE;PH,+,M1.4,L4.5,ZPC(BLK	6001-001670
QFL01		MEC-FOLDER LOWER;SGH-Z300,EU,-,-,-,-	GH75-06764A
QFR01		MEC-FRONT COVER;SGH-Z300,EU,-,-,-,-,	GH75-06762A
	QIF01	PMO-IF COVER;SGH-Z300,PC+URETHANE,BK	GH72-19863A
	QRF03	PMO-COVER EAR;SGH-Z300,PC+URETHANE,B	GH72-22285A
	QVO01	PMO-KEY VOL;SGH-Z300,ABS+URETHANE,SI	GH72-19860A
	QCK01	PMO-KEY CAM;SGH-Z300,ABS+URETHANE,SI	GH72-19861A
QFU01		MEC-FOLDER UPPER(TIM);SGH-Z300,TIM,-	GH75-07316A
QKP01		MEC-KEYPAD MAIN(TIM);SGH-Z300,TIM,-,	GH75-07320A
QLC01		LCD-SGHZ300MODULE;UF-17E096-A,SGH-Z3	GH07-00678A
QLC02		LCD-SGHZ300 SUB MODULE;PM08CC021A,SG	GH07-00742A
QME01		UNIT-KEY PAD;SGH-Z300,EDTGZ300,-,EU,	GH59-02044A
QMO01		MOTOR DC-SGHZ130;DMJBRK20BB,SGH-Z130	GH31-00153K
QMP01		PBA MAIN-SGHZ300;SGH-Z300,XET,EU,PBA	GH92-02176A
QMW01		MEC-MAIN WIN DUMMY;SGH-Z300,EU,-,-,-	GH75-06768A
QRE01		MEC-REAR COVER;SGH-Z300,EU,-,-,-,-,D	GH75-06765A
QRF01		MPR-RF CAP;SGH-Z300,0.2T PC SHEET,6.	GH74-14085A
QSC01		MPR-SCREW CAP;SGH-Z300,0.3T PC SHEET	GH74-14084A
QSC14		MPR-TAPE FRONT HOLE;SGH-Z300,PET T0.	GH74-15598A
QSH01		NDC-SHIELD CAN;- ,SGH-Z300,MAGNESIUM,	GH71-04748A
QWD03		MEC-DUAL WIN DUMMY;SGH-Z300,EU,-,-,-,-	GH75-06767A

SEC CODE	Description
6902-000634	BAG PE; LDPE, T0.05, W80, L180, TRP, -, -
GH39-00395A	CBF INTERFACE-PC DATA CABLE; SGH-Z500
GH44-00701A	CHARGER-TCH; TCH137ESE, SGH-X910, AC/DC
GH46-00145A	S/W CD-SAMSUNG PC STUDIO; SGH-Z500, SG
GH59-01713A	UNIT-EARPHONE; SGH-Z107, EM-SS650E-ST,
GH68-02026A	LABEL(P)-WATER SOAK; SCH-X110, NORGE, 1
GH68-06982B	LABEL(R)-MAIN(TIM); SGH-Z300, TIM, POLY
GH68-07013A	MANUAL-WEEE CARD; SGH-E720, SEC, ENGLIS
GH68-07301A	MANUAL-USER; SGH-Z300, TIM, ITALIAN, ITA
GH69-02925C	BOX(P)-UNIT(TIM); SGH-Z300, SC350+S120
GH69-03002A	CUSHION-CASE(OPEN); SGH-Z300, PULP, T0.
GH74-07571A	MPR-UPPER LOGO GOHO VINYL; SGH-E310, VI
GH74-13606A	MPR-BOHO VINYL IF; SGH-E720, #950, 85X1
GH74-15543A	MPR-SPONGE MIC; SGH-Z300, SRS PORON, 81
GH75-03673H	MEC-HANGER; SGH-Z500, TMN, STRAP, -, BLK,

3-3. Test Jig (GH80-03305A)



3-3-1. RF Test Cable (GH39-00105A)



3-3-2. Test Cable (GH39-00210A)



3-3-3. Serial Cable



3-3-4. Power Supply Cable



3-3-5. DATA CABLE (GH39-00208A)



3-3-6. TC (GH44-00482A)



4. Electrical Part List

Design LOC	Description	SEC CODE
ANT601	ANTENNA	NEW-ITEM005
BAT201	BATTERY	4302-001180
C101, C102, C103, C104	C-CERAMIC, CHIP	2203-005482
C105, C106, C107, C108	C-CERAMIC, CHIP	2203-005482
C111, C112, C113, C114	C-CERAMIC, CHIP	2203-005482
C115, C117, C119, C120	C-CERAMIC, CHIP	2203-005482
C118, C204, C224, C233	C-CERAMIC, CHIP	2203-006093
C121, C122, C123, C124	C-CERAMIC, CHIP	2203-005482
C125, C126, C127, C128	C-CERAMIC, CHIP	2203-005482
C132, C133, C134, C135	C-CERAMIC, CHIP	2203-005482
C136, C137, C138, C149	C-CERAMIC, CHIP	2203-005482
C141	C-CERAMIC, CHIP	2203-000489
C142, C143	C-CERAMIC, CHIP	2203-000628
C144, C245, C246, C406	C-CERAMIC, CHIP	2203-000812
C145, C148, C250, C254	C-CERAMIC, CHIP	2203-000254
C146, C208, C247, C301	C-CERAMIC, CHIP	2203-005061
C147	C-CERAMIC, CHIP	2203-005480
C151, C153, C154, C156	C-CERAMIC, CHIP	2203-005482
C152, C155	C-CERAMIC, CHIP	2203-006091
C201, C203	C-CERAMIC, CHIP	2203-005138
C202, C214, C216, C217	C-CERAMIC, CHIP	2203-006201
C205, C237, C238, C239	C-CERAMIC, CHIP	2203-005482
C206, C209, C211, C213	C-CERAMIC, CHIP	2203-000278
C207, C226, C228, C316	C-CERAMIC, CHIP	2203-000438
C210	C-CERAMIC, CHIP	2203-005065
C212, C219, C221, C225	C-CERAMIC, CHIP	2203-006208
C215, C220, C502, C504	C-CERAMIC, CHIP	2203-000278
C218, C222, C223, C601	C-CERAMIC, CHIP	2203-006201
C227, C234, C235, C236	C-CERAMIC, CHIP	2203-006208
C229, C230	C-CERAMIC, CHIP	2203-000425
C240, C241, C242, C243	C-CERAMIC, CHIP	2203-005482
C249, C253	C-TA, CHIP	2404-001339
C251, C252, C401, C402	C-CERAMIC, CHIP	2203-006208
C255, C256, C310	C-CERAMIC, CHIP	2203-006053
C302, C303, C307, C308	C-CERAMIC, CHIP	2203-005061
C304, C305, C613, C614	C-CERAMIC, CHIP	2203-000233
C306	C-TA, CHIP	2404-001377

Electrical Part List

Design LOC	Description	SEC CODE
C309,C508,C510,C535	C-CERAMIC,CHIP	2203-005061
C311,C313,C315,C405	C-CERAMIC,CHIP	2203-005482
C318,C768	C-CERAMIC,CHIP	2203-000654
C319	C-TA,CHIP	2404-001386
C320	C-CERAMIC,CHIP	2203-006257
C321,C506,C533,C607	C-CERAMIC,CHIP	2203-006093
C327,C413,C769	C-TA,CHIP	2404-001305
C403,C404,C776,C777	C-CERAMIC,CHIP	2203-006208
C407,C411,C412,C627	C-CERAMIC,CHIP	2203-005482
C408,C409,C410,C414	C-CERAMIC,CHIP	2203-000812
C501,C505,C507,C511	C-CERAMIC,CHIP	2203-000854
C503,C514,C523,C538	C-CERAMIC,CHIP	2203-000812
C509,C522,C524,C540	C-CERAMIC,CHIP	2203-000278
C512,C788,C795	C-TA,CHIP	2404-001394
C513,C537	C-CERAMIC,CHIP	2203-005057
C516,C531,C534,C548	C-CERAMIC,CHIP	2203-000854
C520,C521,C545,C546	C-CERAMIC,CHIP	2203-000995
C543,C760,C762,C763	C-CERAMIC,CHIP	2203-005061
C602,C606	C-CERAMIC,CHIP	2203-006201
C603,C626,C632,C637	C-CERAMIC,CHIP	2203-000812
C610,C622,C644,C708	C-CERAMIC,CHIP	2203-000438
C611,C612,C617,C660	C-CERAMIC,CHIP	2203-000854
C615,C616,C621,C701	C-CERAMIC,CHIP	2203-000233
C618	C-CERAMIC,CHIP	2203-001385
C620	C-CERAMIC,CHIP	2203-000885
C623,C625,C635,C650	C-CERAMIC,CHIP	2203-006093
C624	C-CERAMIC,CHIP	2203-000278
C628,C759	C-TA,CHIP	2404-001274
C629,C718	C-CERAMIC,CHIP	2203-000995
C630,C631,C636,C642	C-CERAMIC,CHIP	2203-005482
C633	C-CERAMIC,CHIP	2203-000836
C634	C-TA,CHIP	2301-001512
C638,C739	C-CERAMIC,CHIP	2203-000254
C639	C-CERAMIC,CHIP	2203-000311
C640	C-TA,CHIP	2301-001197
C641	C-CERAMIC,CHIP	2203-000609
C643,C652,C655,C662	C-CERAMIC,CHIP	2203-000812

Design LOC	Description	SEC CODE
C645	C-CERAMIC,CHIP	2203-005503
C646	C-CERAMIC,CHIP	2203-002443
C647	C-CERAMIC,CHIP	2203-005234
C648,C649,C653,C656	C-CERAMIC,CHIP	2203-005482
C651,C658,C753	C-CERAMIC,CHIP	2203-000386
C654,C661,C665,C761	C-CERAMIC,CHIP	2203-006093
C657,C659,C666,C704	C-CERAMIC,CHIP	2203-005482
C663,C664,C711,C736	C-CERAMIC,CHIP	2203-000812
C667,C668,C669,C670	C-CERAMIC,CHIP	2203-000359
C703,C707,C719,C723	C-CERAMIC,CHIP	2203-000233
C705,C710,C712,C717	C-CERAMIC,CHIP	2203-000330
C709	C-TA,CHIP	2404-001105
C715	C-CERAMIC,CHIP	2203-001383
C720,C724,C726,C730	C-CERAMIC,CHIP	2203-005482
C725,C727,C732,C735	C-CERAMIC,CHIP	2203-000233
C728,C733	C-CERAMIC,CHIP	2203-005288
C729,C749	C-CERAMIC,CHIP	2203-000438
C731,C734,C737,C740	C-CERAMIC,CHIP	2203-005482
C738,C741,C744,C757	C-CERAMIC,CHIP	2203-000233
C742	C-CERAMIC,CHIP	2203-000330
C743,C748,C752,C758	C-CERAMIC,CHIP	2203-005482
C746	C-CERAMIC,CHIP	2203-000812
C747,C796	C-CERAMIC,CHIP	2203-006324
C750	C-CERAMIC,CHIP	2203-000679
C751	C-TA,CHIP	2404-001086
C754	C-CERAMIC,CHIP	2203-001124
C755	C-CERAMIC,CHIP	2203-000585
C756	C-TA,CHIP	2301-001214
C764,C773,C778,C779	C-CERAMIC,CHIP	2203-006093
C766,C786,C787,C789	C-CERAMIC,CHIP	2203-005061
C767,C772	C-CERAMIC,CHIP	2203-005482
C774,C775	C-CERAMIC,CHIP	2203-006137
C780,C781,C784,C785	C-CERAMIC,CHIP	2203-006093
C782,C783	C-TA,CHIP	2404-001312
C790,C791,C792	C-CERAMIC,CHIP	2203-005061
C793	C-CERAMIC,CHIP	2203-006093
C794	C-CERAMIC,CHIP	2203-006208

Electrical Part List

Design LOC	Description	SEC CODE
CA500,ZD401	DIODE-ZENER	0406-001208
CN200	CONNECTOR	3709-001357
CN301	CONNECTOR	3709-001344
CN401	CONNECTOR	3710-002120
CN402	CONNECTOR	3711-005782
CN403	CONNECTOR	3711-005605
D100,ZD201	DIODE-ZENER	0404-001110
EAR500	EAR CONNECTOR	3722-002082
F401,F402,F403,F404	FILTER	2901-001286
F405,F704,F705	FILTER	2901-001286
F601	FILTER	2904-001550
F602	FILTER	NEW-ITEM006
F603	FILTER	NEW-ITEM015
F701	FILTER	2904-001439
F702	DUPLEXER	NEW-ITEM004
F703	FILTER	2904-001438
HEA401	CONNECTOR-HEADER	NEW-ITEM016
IRDA301	HSDL-3208	0604-001261
L202,L203	INDUCTOR-SMD	NEW-ITEM014
L501,L502,L503,L504	INDUCTOR-SMD	2703-001938
L602,L621,L622,L623	INDUCTOR-SMD	2703-002155
L604,L606	INDUCTOR-SMD	2703-002208
L605,L607	INDUCTOR-SMD	2703-002203
L608,L610	INDUCTOR-SMD	2703-002207
L609	INDUCTOR-SMD	2703-002268
L611,L615	INDUCTOR-SMD	2703-002198
L612,L614	INDUCTOR-SMD	2703-002176
L613	INDUCTOR-SMD	2703-002170
L616,L619,L620	INDUCTOR-SMD	3301-001342
L617,R106,R107,R108	R-CHIP	2007-000171
L618	INDUCTOR-SMD	2703-002369
L701,L708	INDUCTOR-SMD	2703-002314
L702	INDUCTOR-SMD	2703-001786
L703	INDUCTOR-SMD	2703-001751
L704	INDUCTOR-SMD	2703-001747
L705	INDUCTOR-SMD	2703-001733
L706	INDUCTOR-SMD	2703-001750

Design LOC	Description	SEC CODE
L707,L711	INDUCTOR-SMD	2703-002155
L709,L710	INDUCTOR-SMD	2703-001729
L712,L713	INDUCTOR-SMD	3301-001756
OSC100	VCO	2802-001182
OSC601	RF-VCO	NEW-ITEM009
OSC701	VC-TCXO	2809-001280
OSC702	VCO	NEW-ITEM012
Q1	COMP-SMD	NEW-ITEM003
R109,R110,R111	R-CHIP	2007-000171
R117,R121,R124,R125	R-CHIP	2007-000171
R119,R153,R154	R-CHIP	2007-000143
R126,R128,R136,R701	R-CHIP	2007-007314
R127,R143,R155,R203	R-CHIP	2007-000171
R129,R404,R405,R406	R-CHIP	2007-000140
R130,R516,R521,R534	R-CHIP	2007-000141
R133	R-CHIP	2007-007318
R135	R-CHIP	2007-007135
R145,R225,R506,R544	R-CHIP	2007-000162
R149,R152,R205,R231	R-CHIP	2007-000148
R150,R151	R-CHIP	2007-001339
R201,R204	R-CHIP	2007-003015
R202	R-CHIP	2007-000157
R208	R-CHIP	2007-001298
R209	R-CHIP	2007-007468
R211,R226,R227,R228	R-CHIP	2007-000171
R219	R-CHIP	2007-000153
R223	R-CHIP	2007-000151
R229,R230,R233,R301	R-CHIP	2007-000171
R302,R303,R309,R310	R-CHIP	2007-000171
R307,R519,R538,R749	R-CHIP	2007-000148
R312,R609,R610,R611	R-CHIP	2007-001325
R316,R742,R745,R746	R-CHIP	2007-000775
R319,R320	R-CHIP	2007-003022
R322,R323,R325,R402	R-CHIP	2007-000171
R326	R-CHIP	2007-000166
R401,R409,R410,R412	R-CHIP	2007-000173
R403,R631	R-CHIP	2007-000172

Electrical Part List

Design LOC	Description	SEC CODE
R407 ,R408 ,R612	R-CHIP	2007-000140
R414 ,R415 ,R702	R-CHIP	2007-000173
R416 ,R515 ,R517 ,R520	R-CHIP	2007-000171
R502 ,R734	R-CHIP	2007-000168
R503	R-CHIP	2007-003010
R507	R-CHIP	2007-000165
R510 ,R747 ,R748	R-CHIP	2007-000159
R522 ,R525 ,R528 ,R530	R-CHIP	2007-000171
R543 ,R705	R-CHIP	2007-000141
R601 ,R602 ,R603 ,R604	R-CHIP	2007-000171
R605 ,R606 ,R607 ,R608	R-CHIP	2007-000171
R613 ,R633 ,R634	R-CHIP	2007-001217
R614 ,R620	R-CHIP	2007-001290
R615 ,R616 ,R623 ,R624	R-CHIP	2007-000139
R617 ,R628 ,R630 ,R632	R-CHIP	2007-000138
R618	R-CHIP	2007-000145
R619	R-CHIP	2007-001325
R621	R-CHIP	2007-001306
R622	R-CHIP	2007-001301
R625	R-CHIP	2007-000147
R626	R-CHIP	2007-007142
R627 ,R717 ,R725 ,R728	R-CHIP	2007-000171
R629 ,R706	R-CHIP	2007-007491
R703 ,R707 ,R710	R-CHIP	2007-000138
R704	R-CHIP	2007-001156
R708	R-CHIP	2007-002965
R709	R-CHIP	2007-007306
R711 ,R716	R-CHIP	2007-001284
R713	R-CHIP	2007-007001
R714	R-CHIP	2007-000142
R715	R-CHIP	2007-000144
R720 ,R758 ,R765 ,R115	R-CHIP	2007-000162
R724 ,R726 ,R727 ,R730	R-CHIP	2007-000156
R729 ,R732 ,R733 ,R738	R-CHIP	2007-000171
R741 ,R743 ,R754 ,R755	R-CHIP	2007-000171
R757	R-CHIP	2007-001119
R759 ,R760 ,R761 ,R762	R-CHIP	2007-007021

Design LOC	Description	SEC CODE
R763, R737	R-CHIP	2007-000148
R768, R769, R770	R-CHIP	2007-000171
RFSW601	RF CONNECTOR	3705-001355
TH100	NCP	1404-001224
U100	MSM	1205-002527
U201	POWER CHIP	1203-003335
U202	MIC2212-GMBML	1203-002969
U203	MIC2211-PSBML	1203-002860
U204	USBUF01W6	0407-001038
U301	FILTER	NEW-ITEM013
U302	AUDIO CHIP	1204-002316
U501, U704	STG3699AQTR	1001-001306
U510	TC75S56FE	1202-001068
U600	ANTENNA SWITCH	NEW-ITEM008
U601	BT Module	NEW-ITEM001
U602	RTR6250	NEW-ITEM010
U603	GSM PAM	1201-002218
U701	WCDMA PAM	1201-002219
U702	RFL6200	1201-001984
U703	RFR	1205-002297
U705	STG3684QTR	1001-001248
U706	FSA4157L6X	1001-001265
U709	COMP-SMD	NEW-ITEM002
U710	AMP	NEW-ITEM011
U711	MIC5205-2.7BM5	1203-002565
U712	R1141Q181DTR	1203-003208
X200	CC7V-T1A-32.768K	NEW-ITEM007
ZD402, ZD407, ZD409	DIODE-ZENER	0403-001387
ZD403, ZD404	DIODE-ZENER	0406-001190
ZD405, ZD406, ZD408	DIODE-ZENER	0406-001197
ZD410	DIODE-ZENER	0403-001387
ZD411	DIODE-ZENER	0406-001197

5. Block Diagrams

5-1. RF Solution Block Diagram

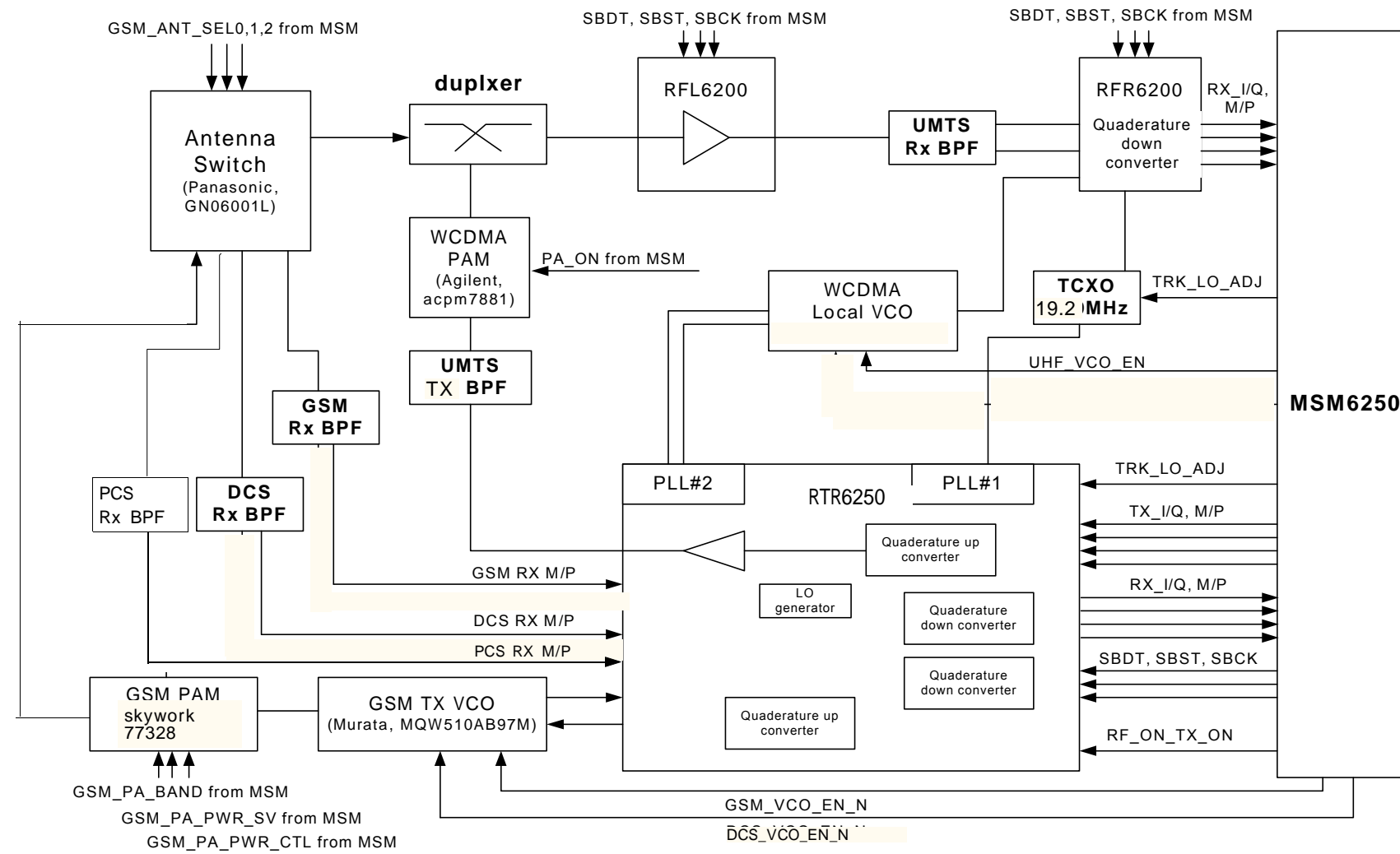

5-2. Base Band Solution Block Diagram

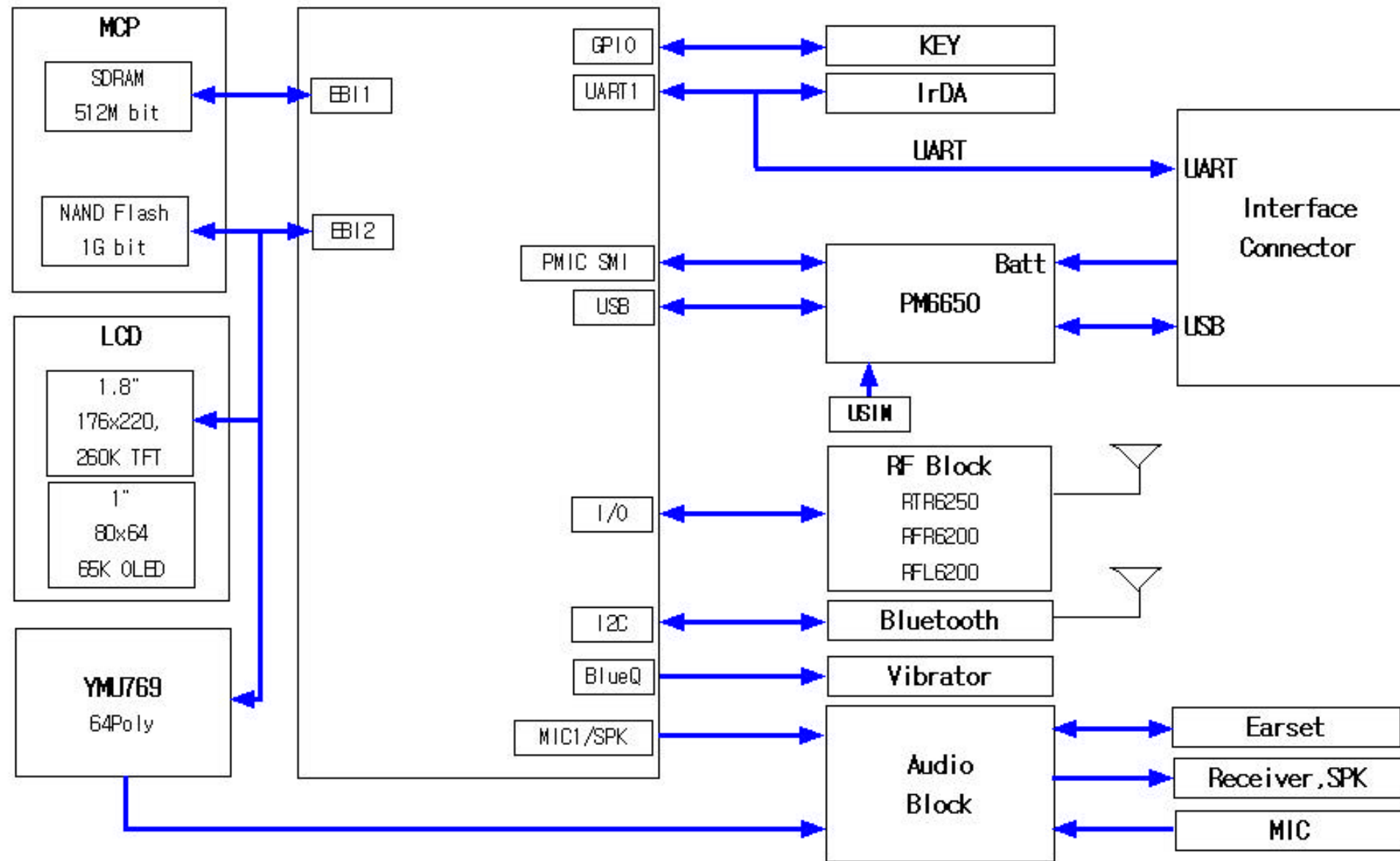

6. PCB Diagrams

6-1. Main PCB Top Diagram

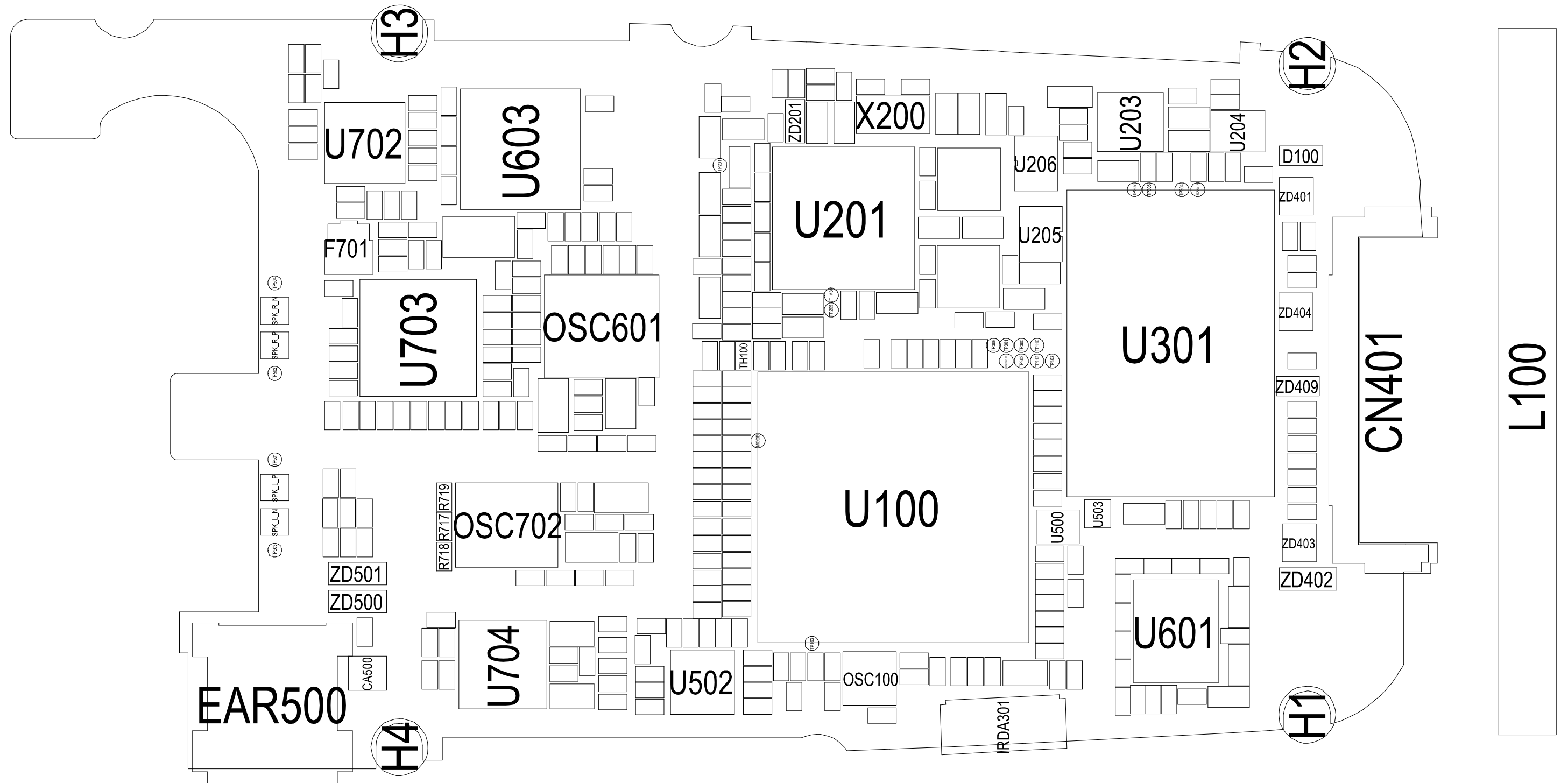

6-2. Main PCB Bottom Diagram

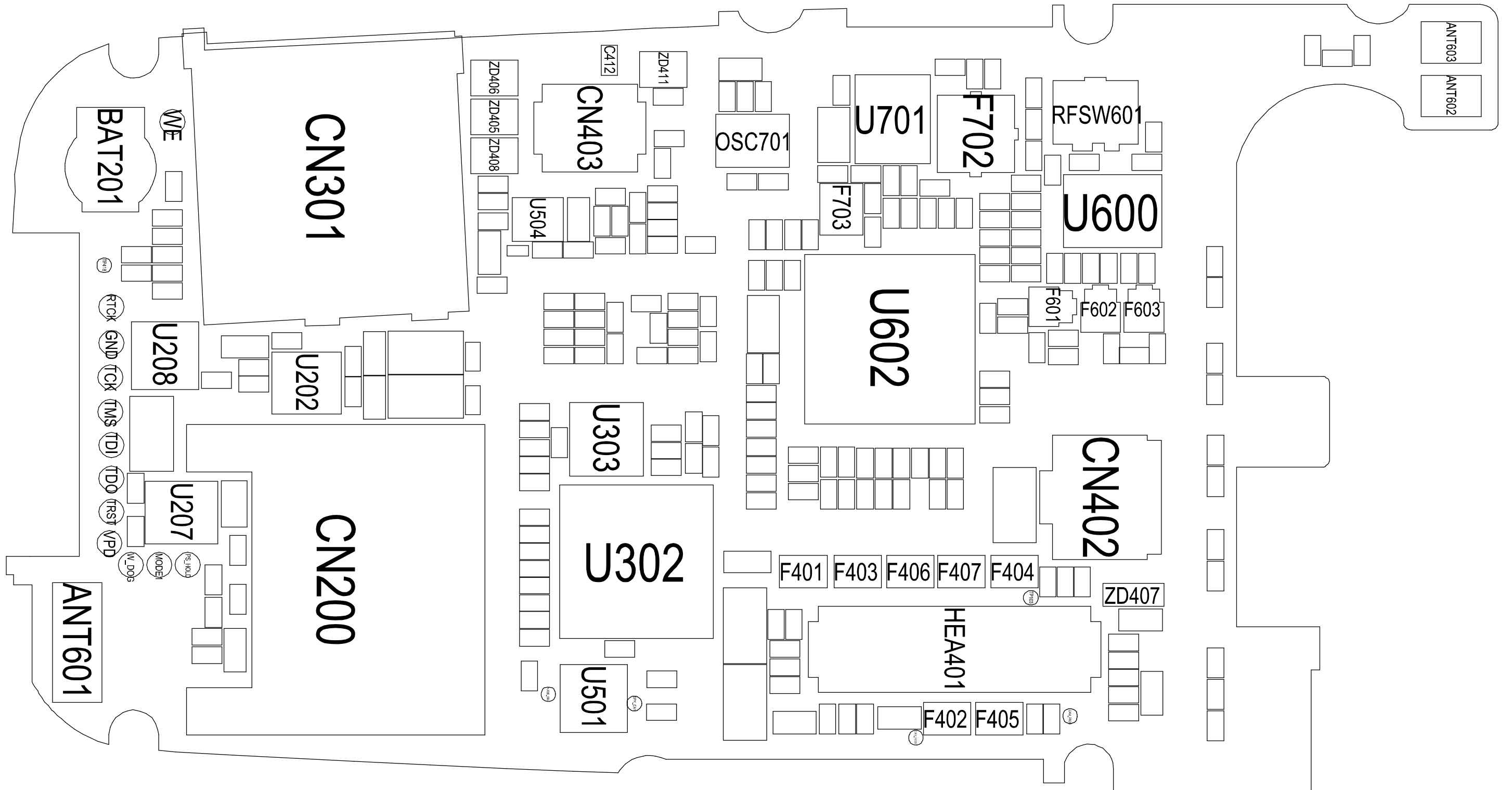

7. Flow Chart of Troubleshooting

7-1. Power On

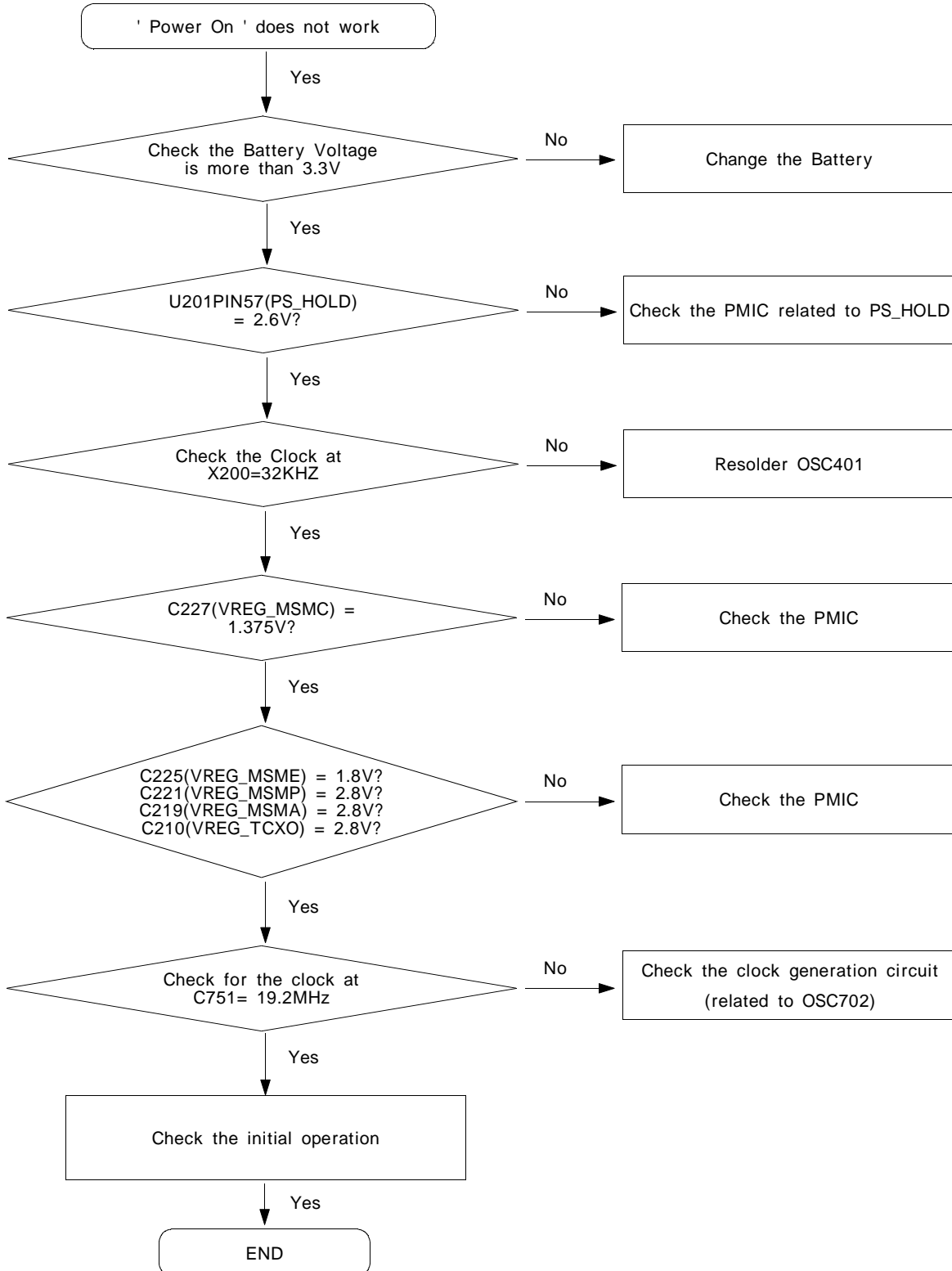

Flow Chart of Troubleshooting

Power On

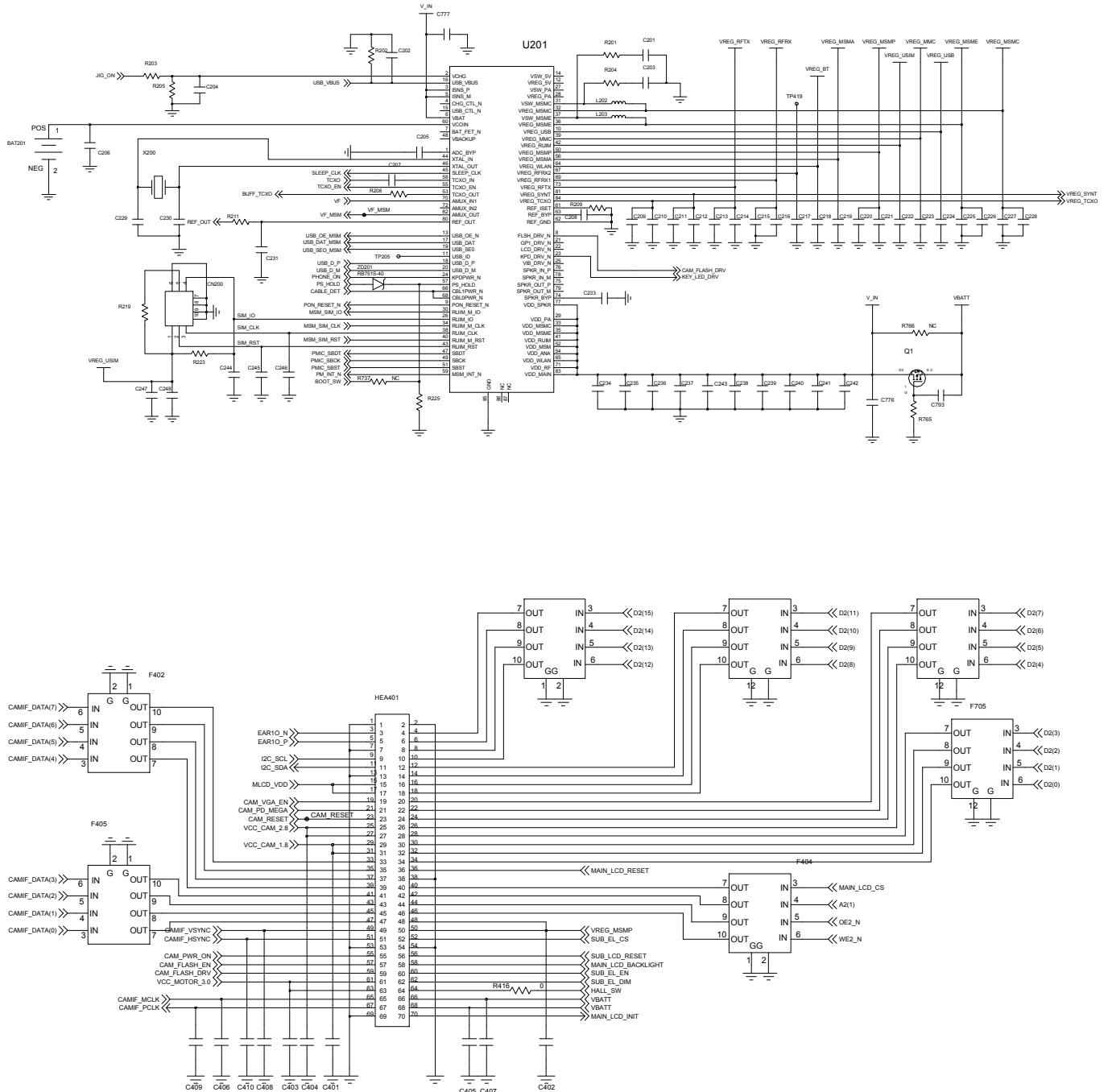

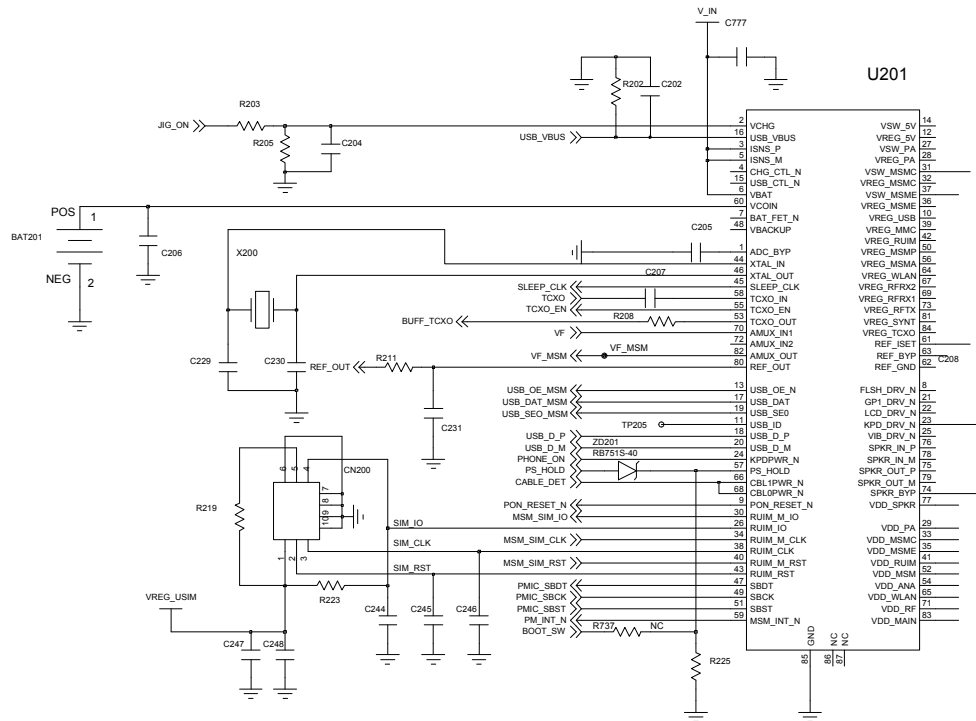

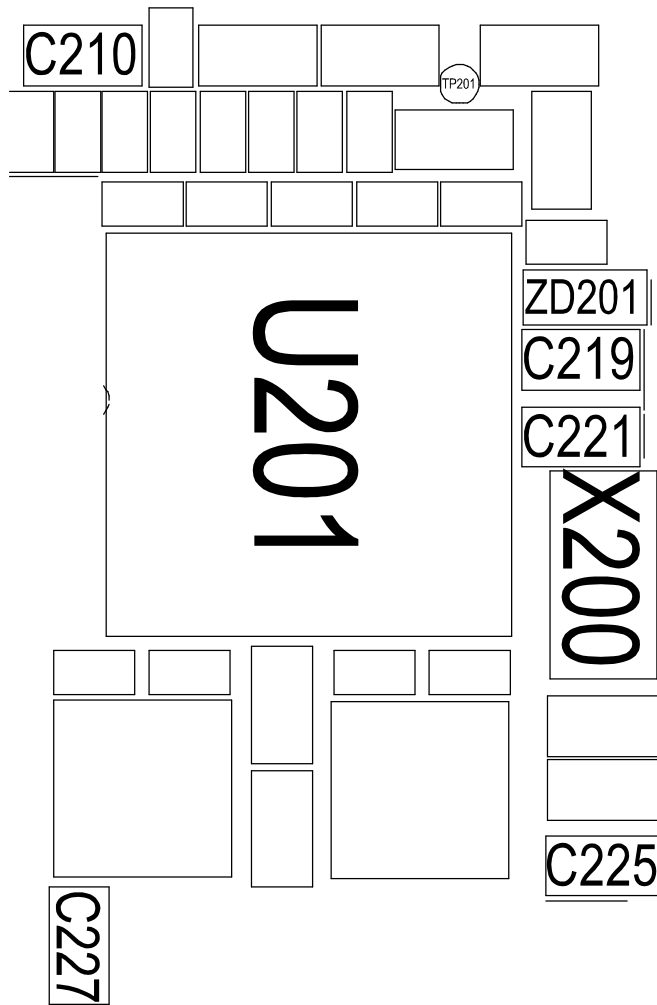

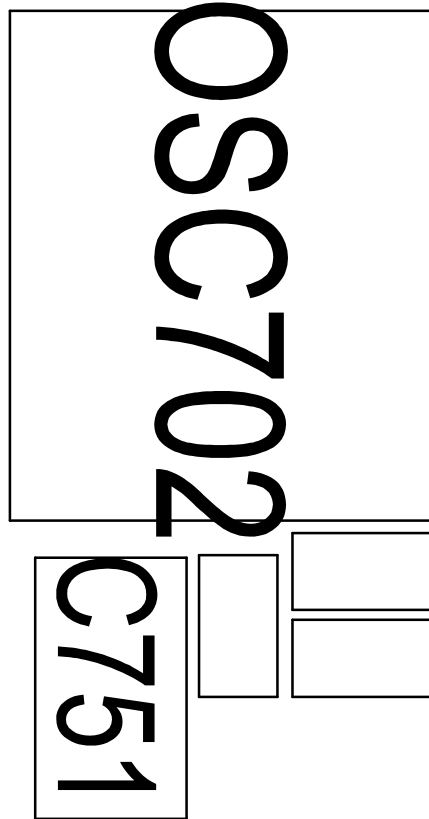

7-2. Initial

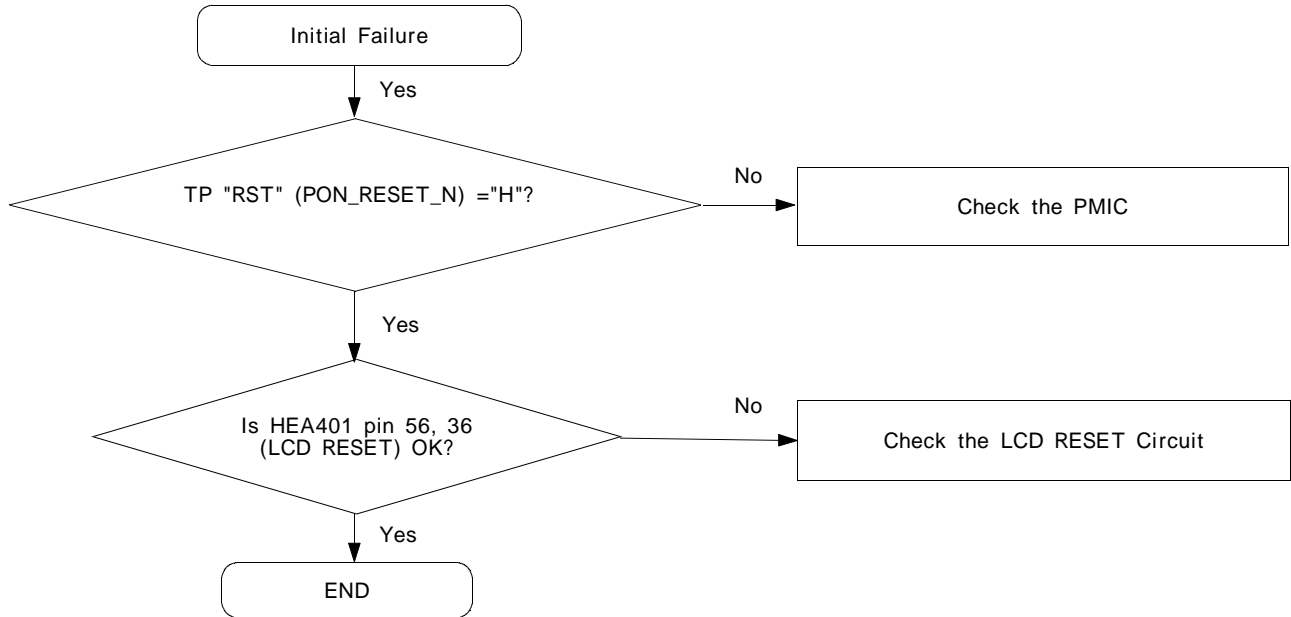

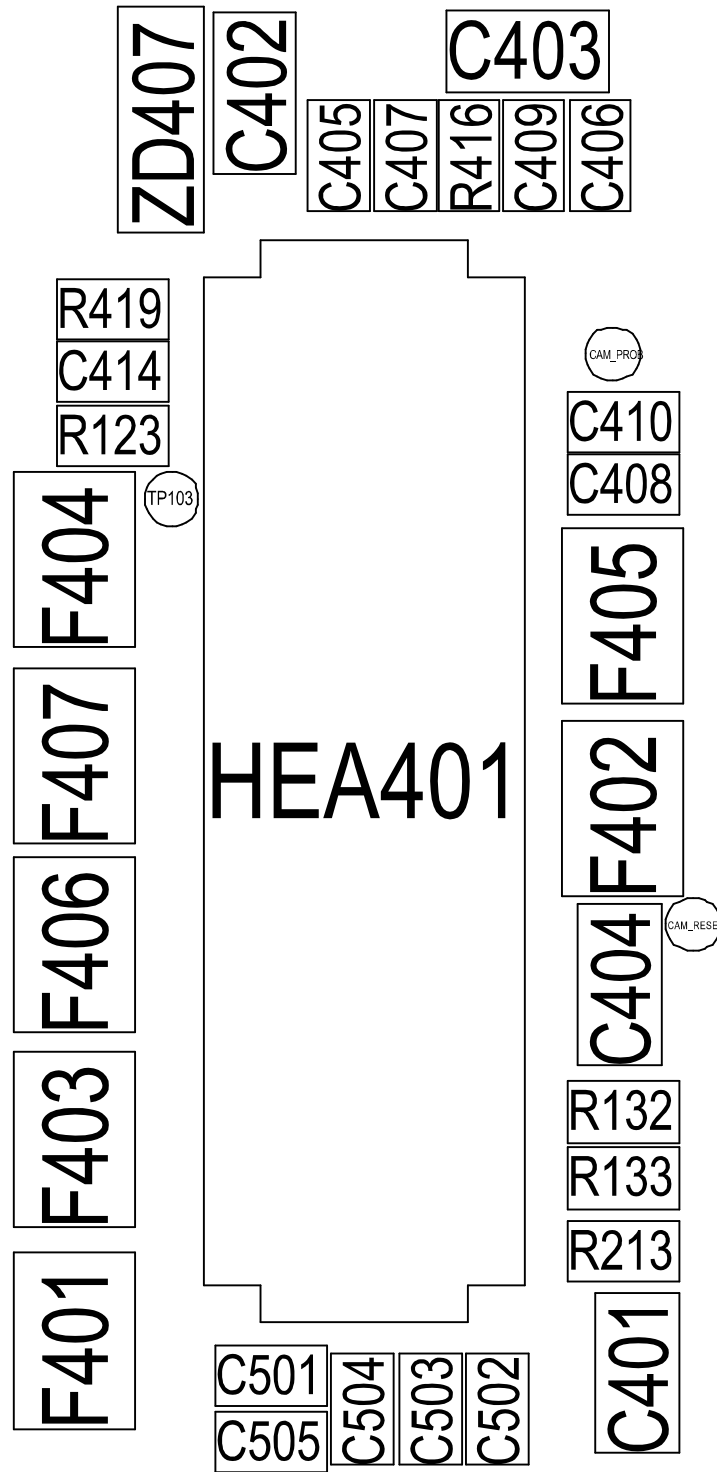

7-3. Sim Part

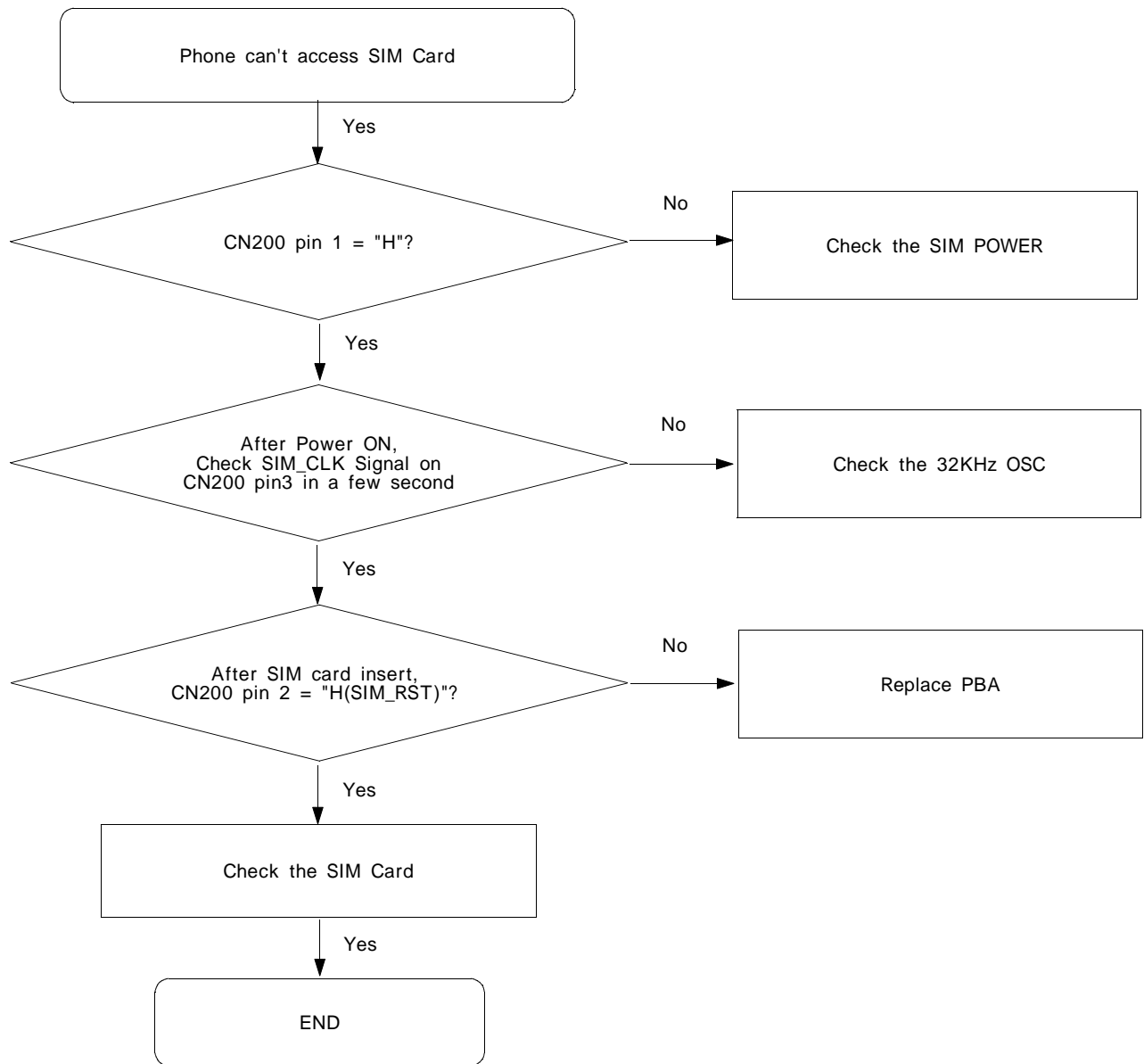

SIM

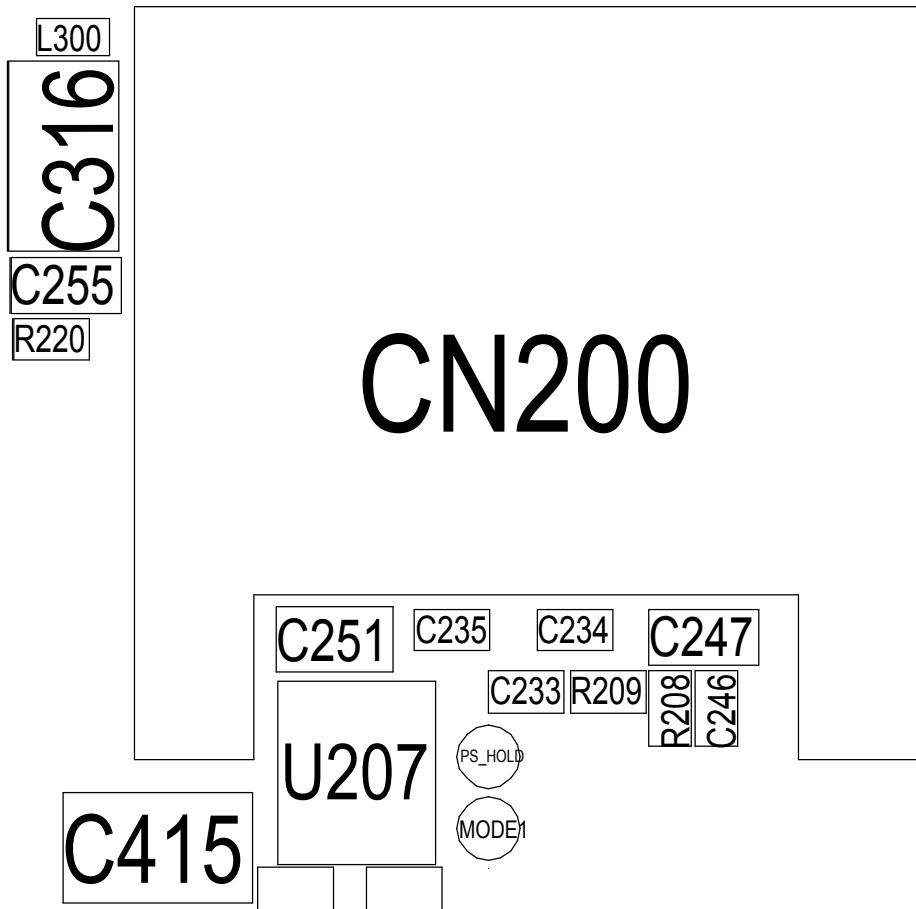
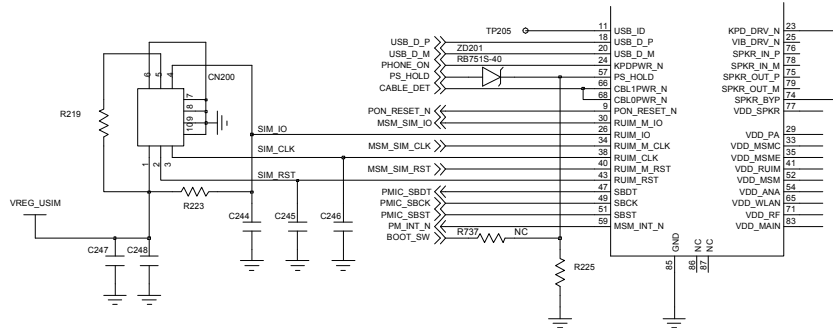

7-4. Speaker Part (Melody)

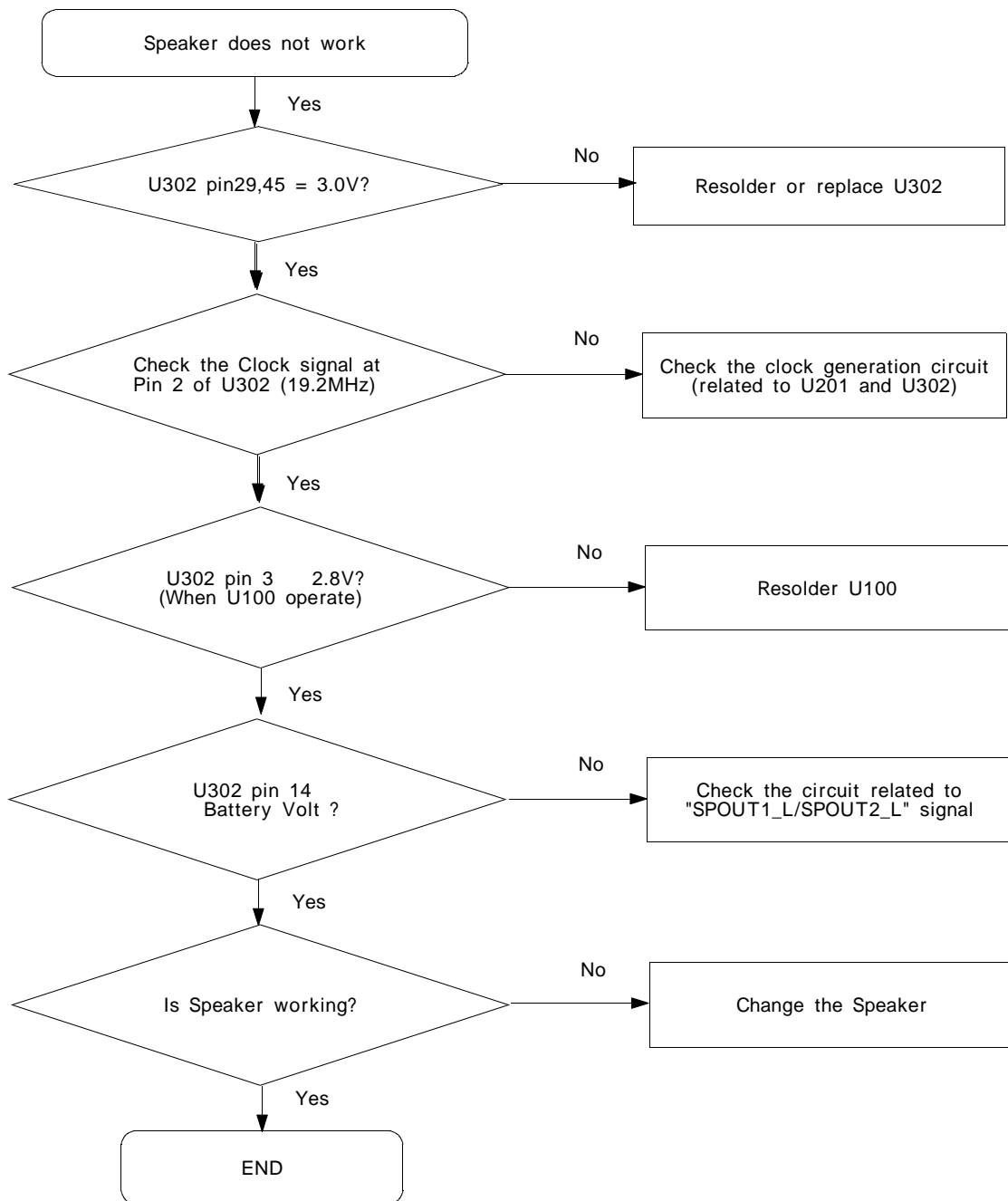

Speaker

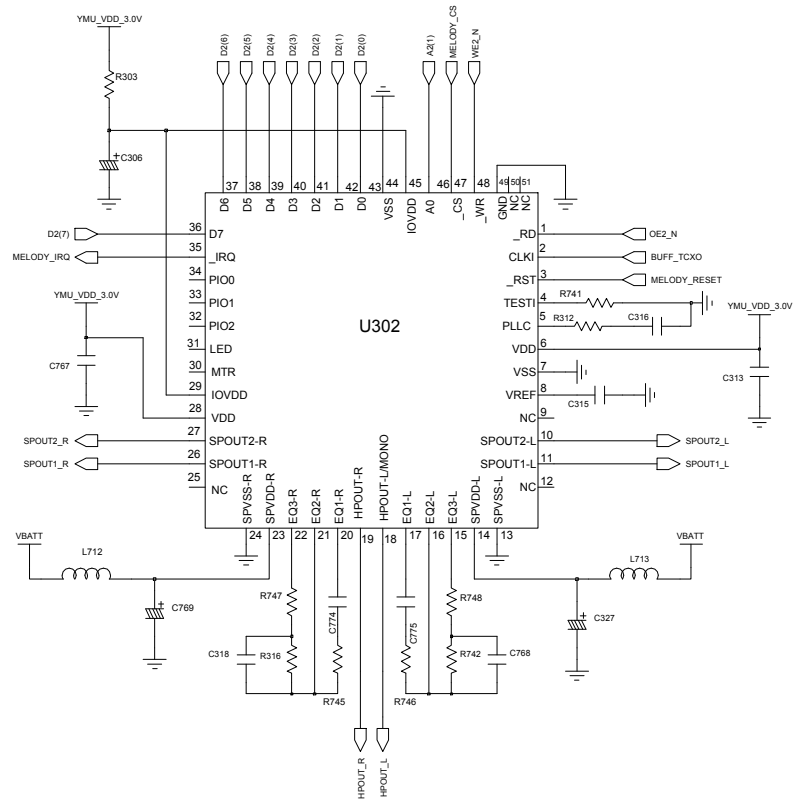

U302

7-5. Microphone Part

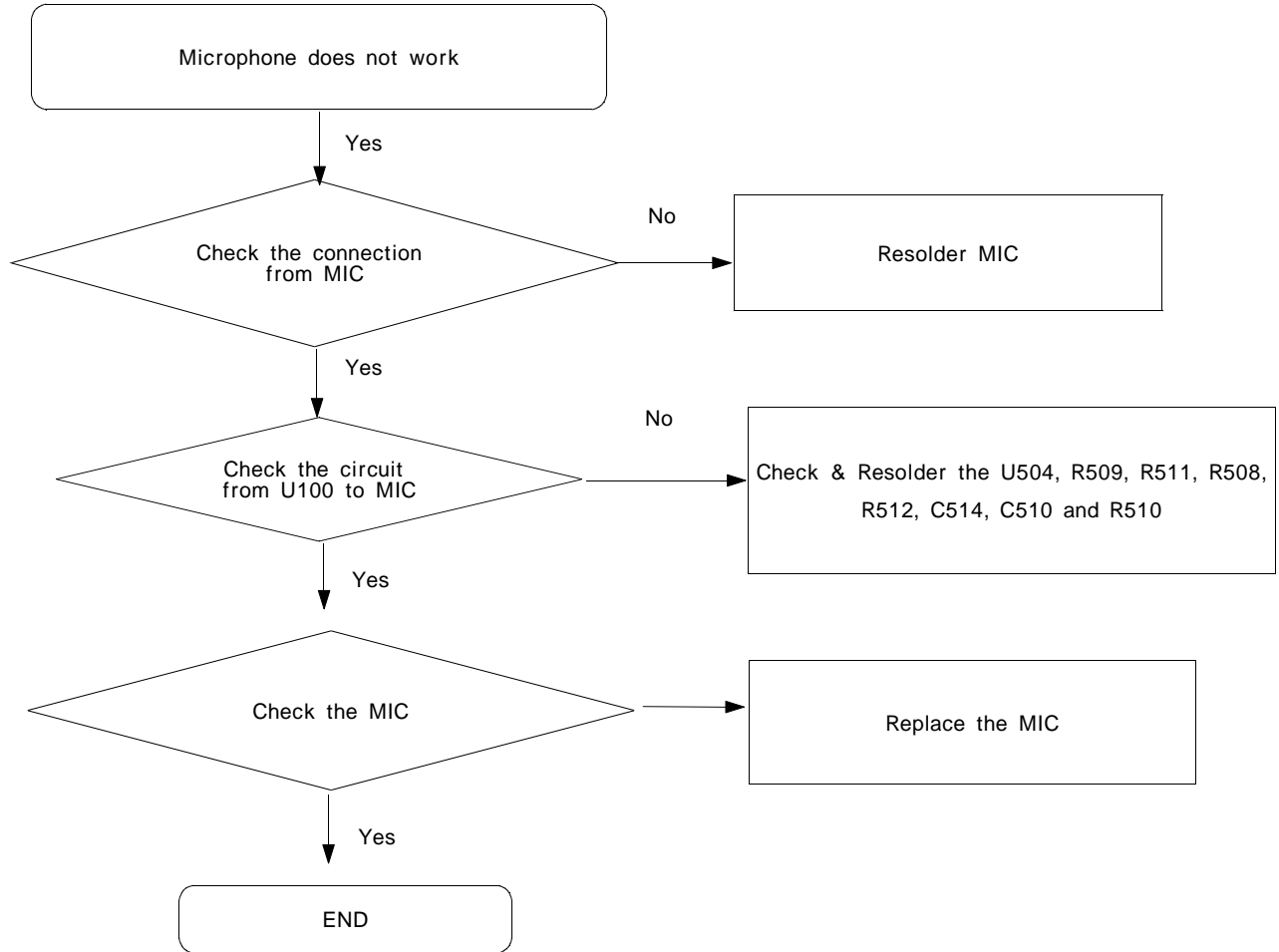

Microphone

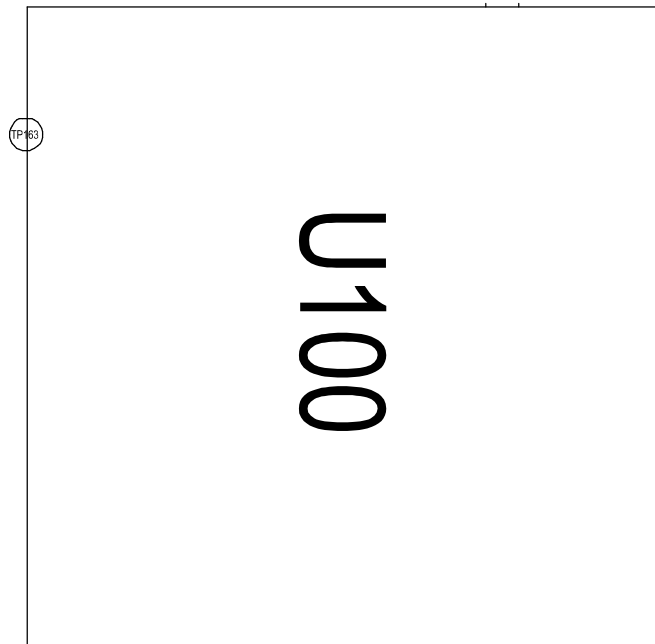
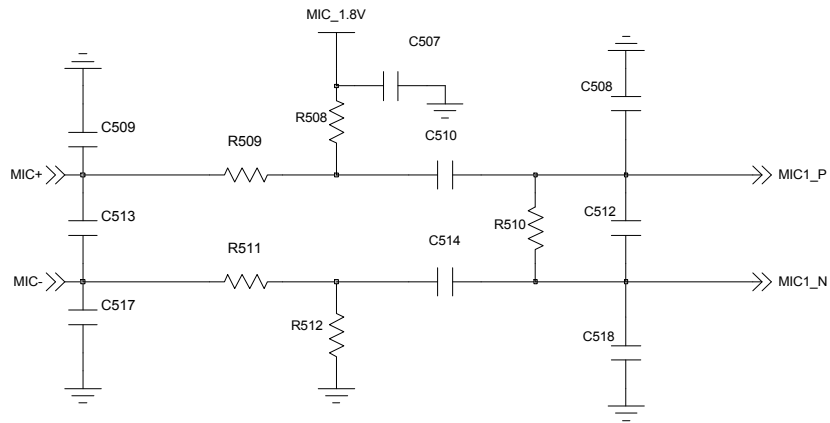

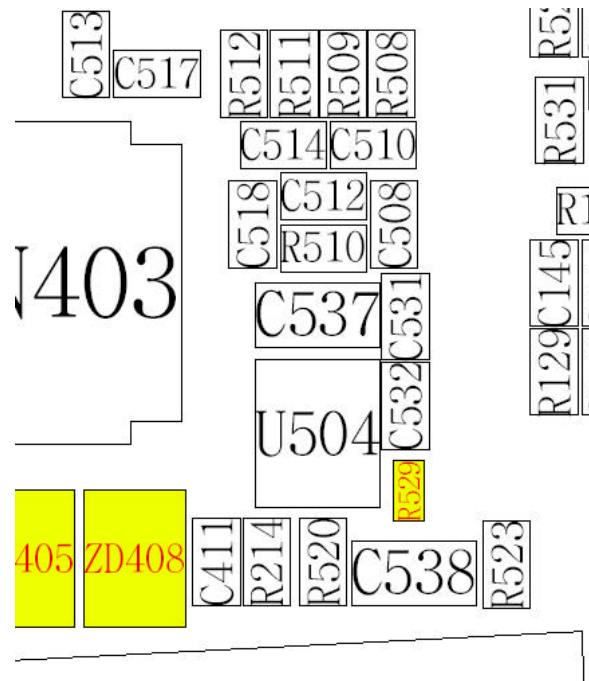

7-6. Key Data Input

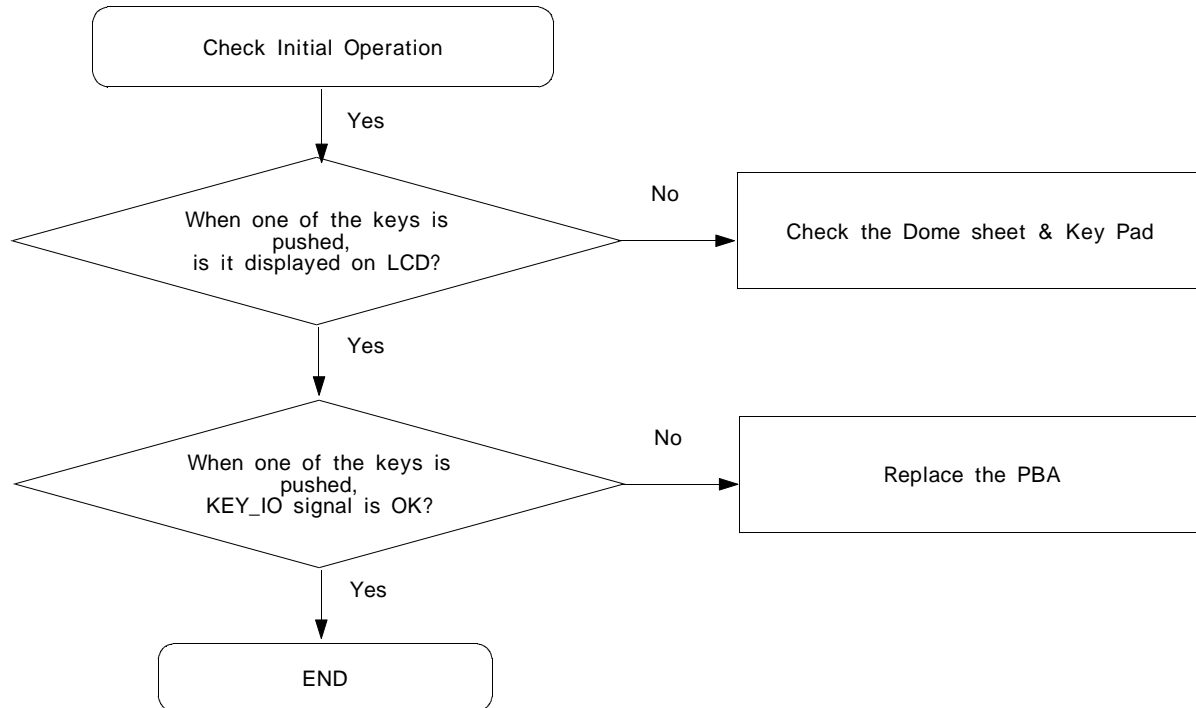

7-7. Receiver Part

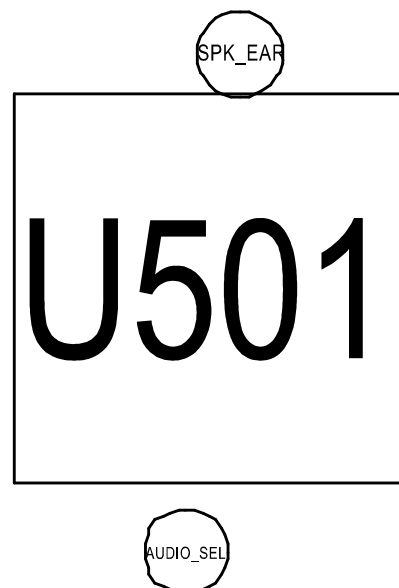
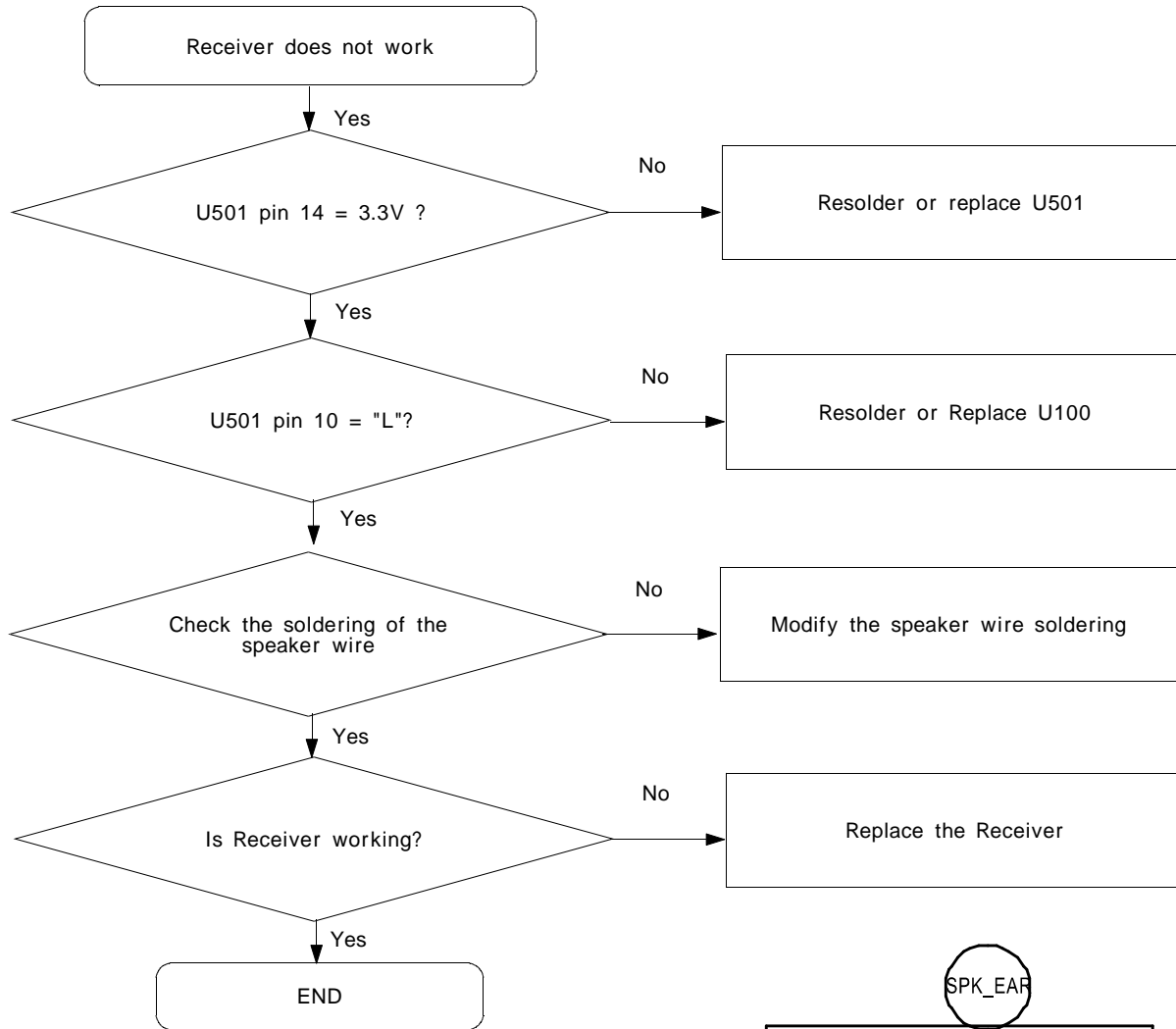

7-8. Back Light (for Color Main LCD)

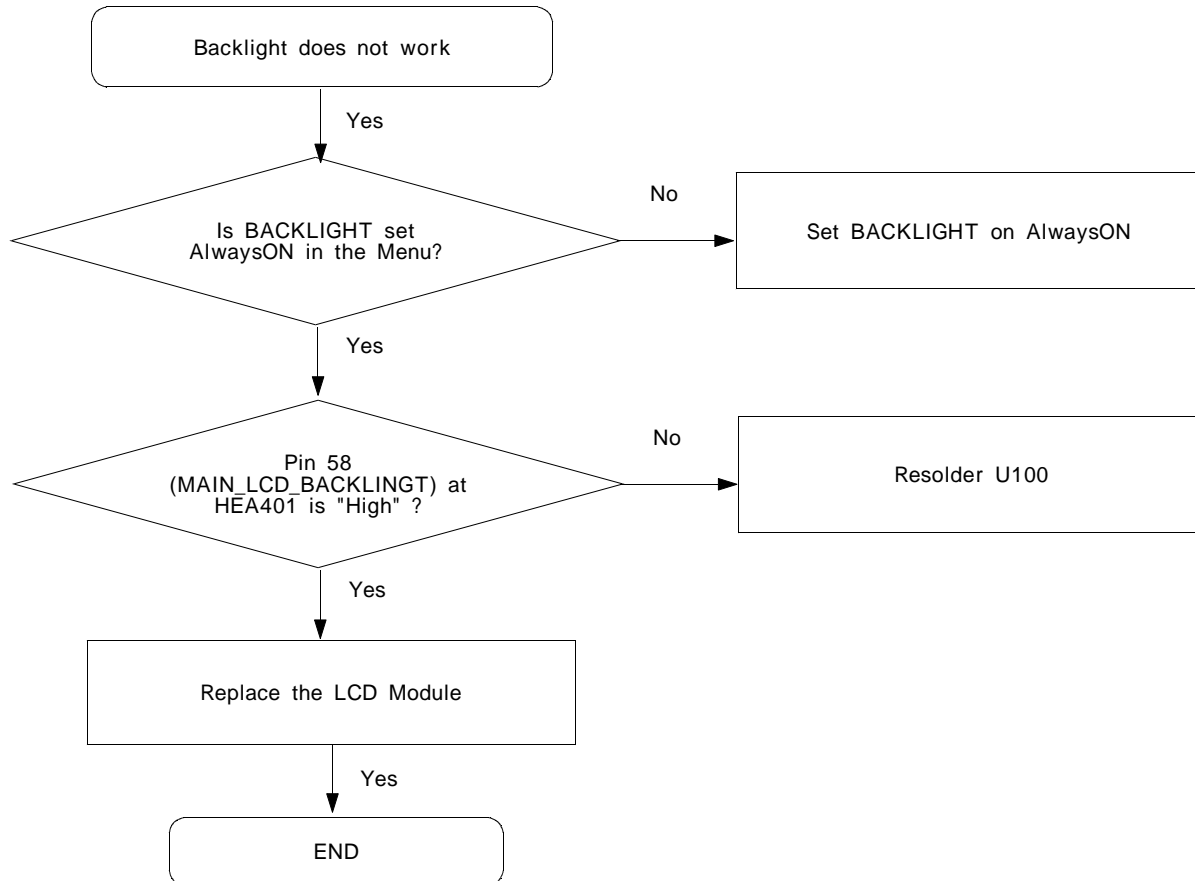

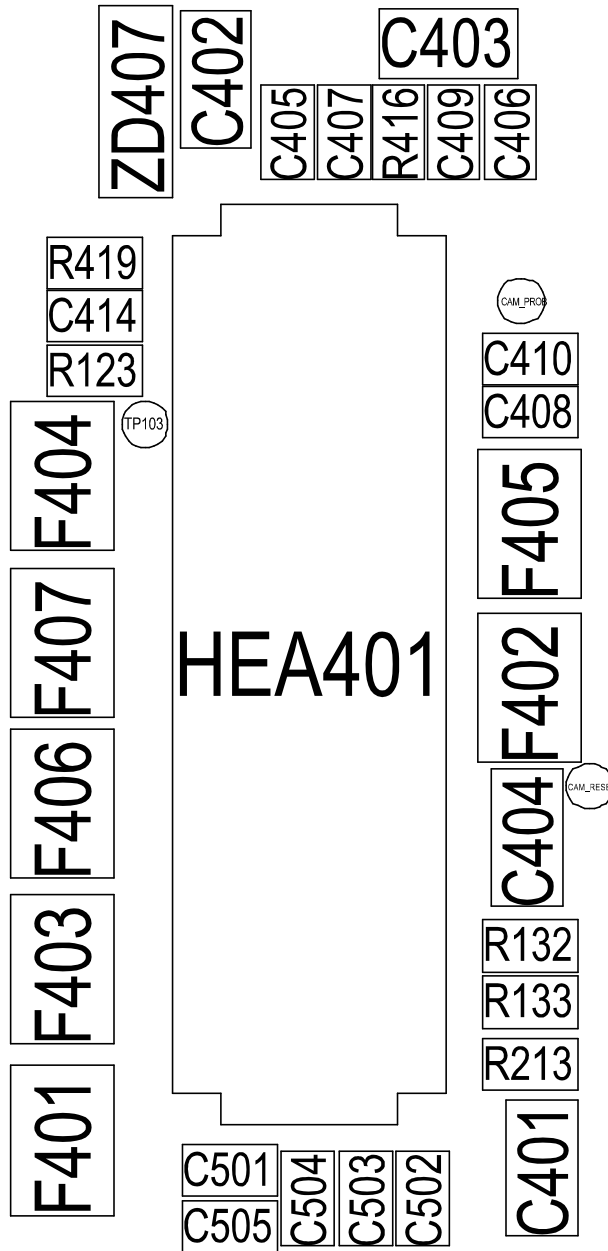

7-9. Key Back Light

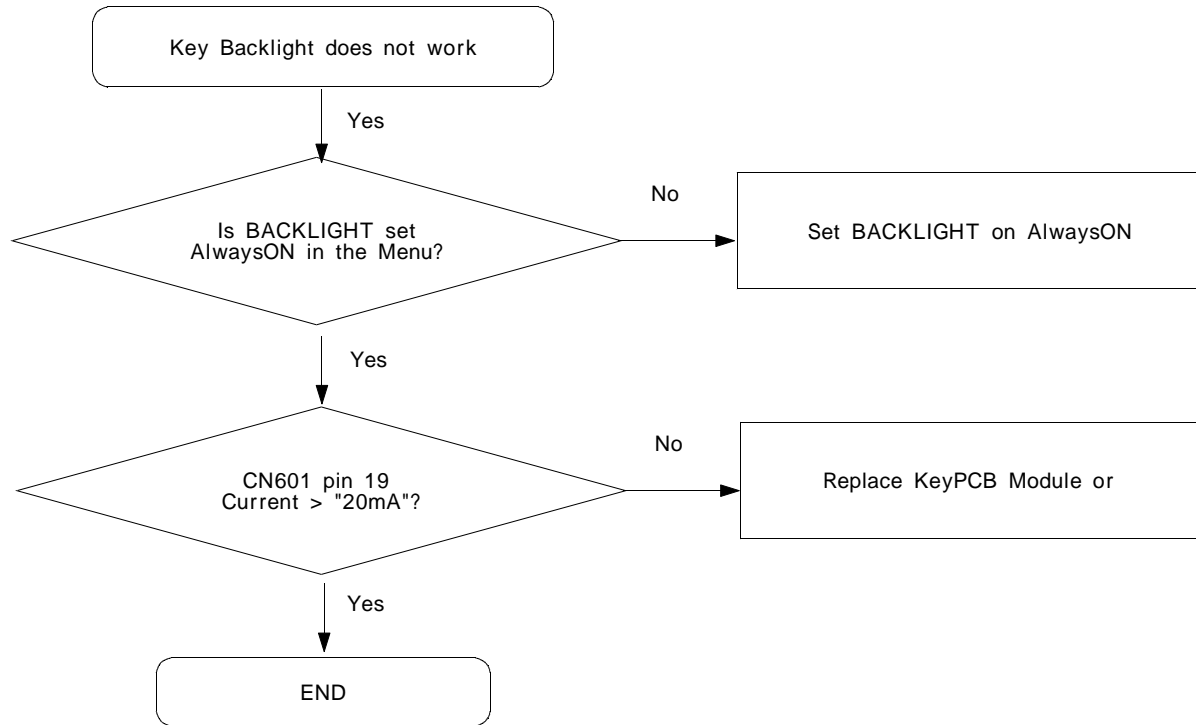

7-10. Camera part

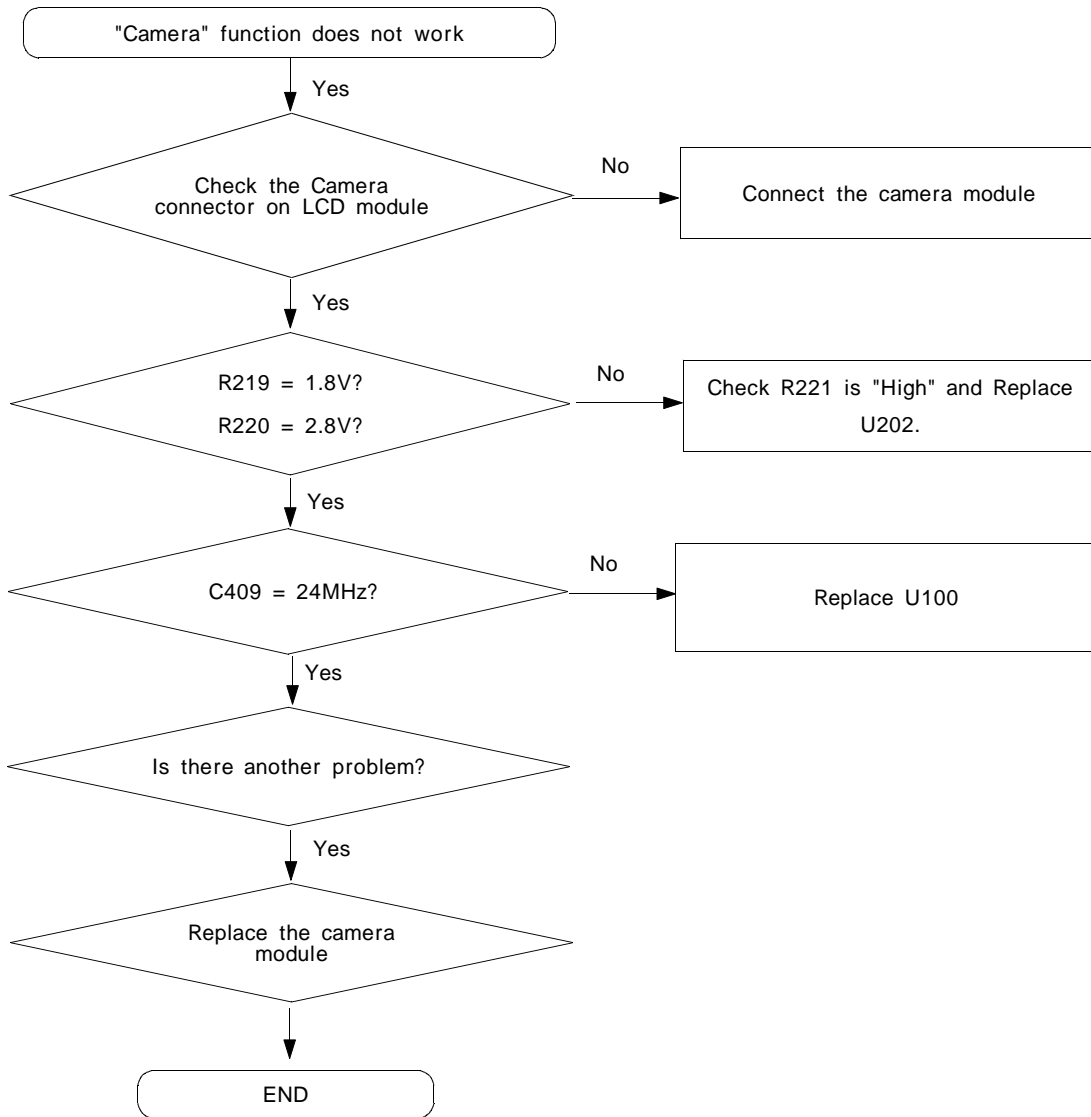

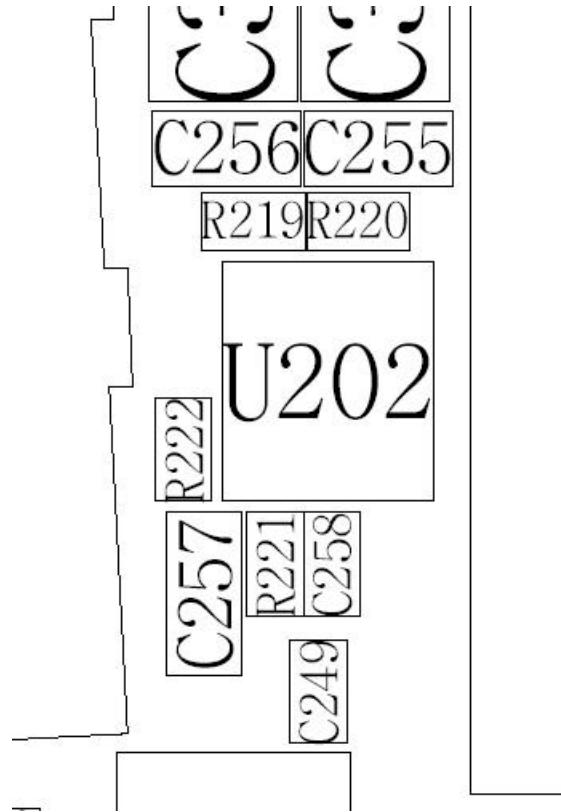

7-11. GSM Receiver

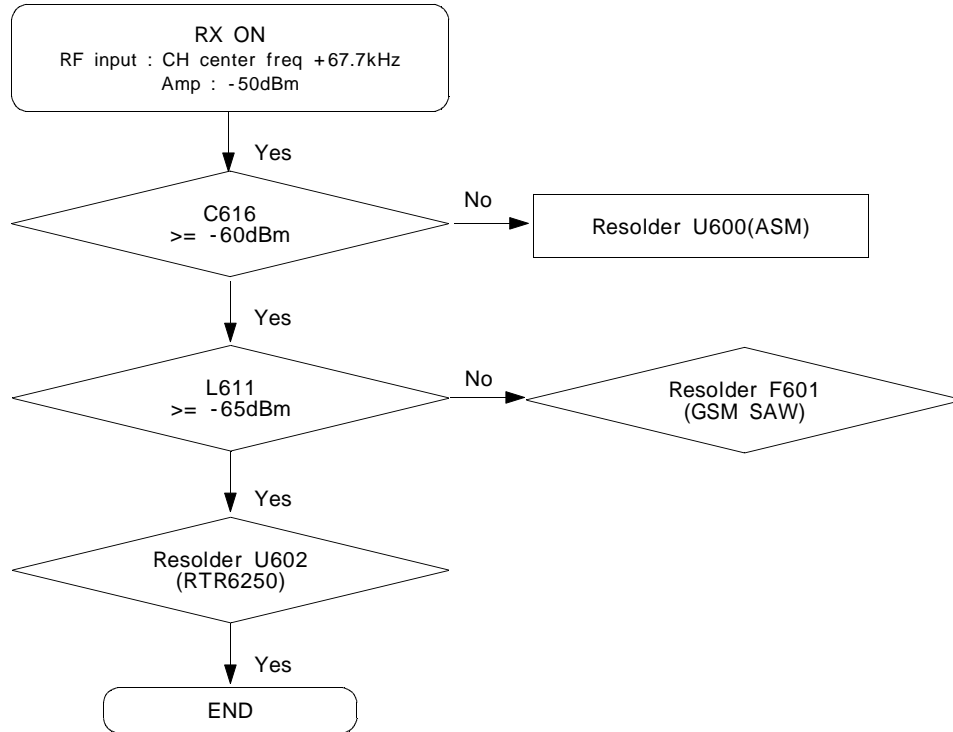

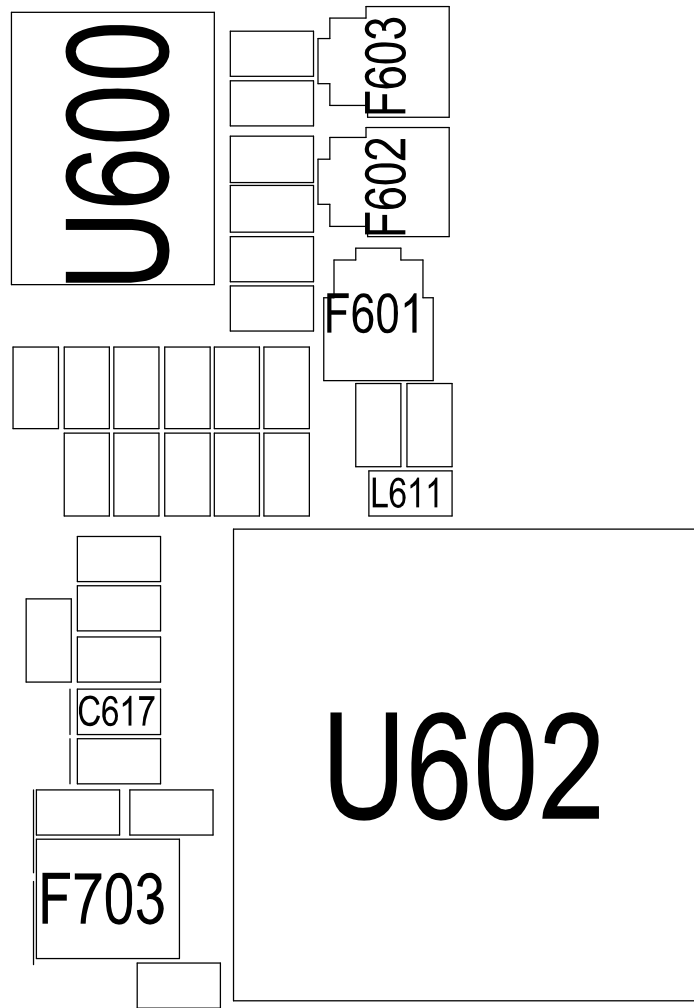

7-12. GSM Transmitter

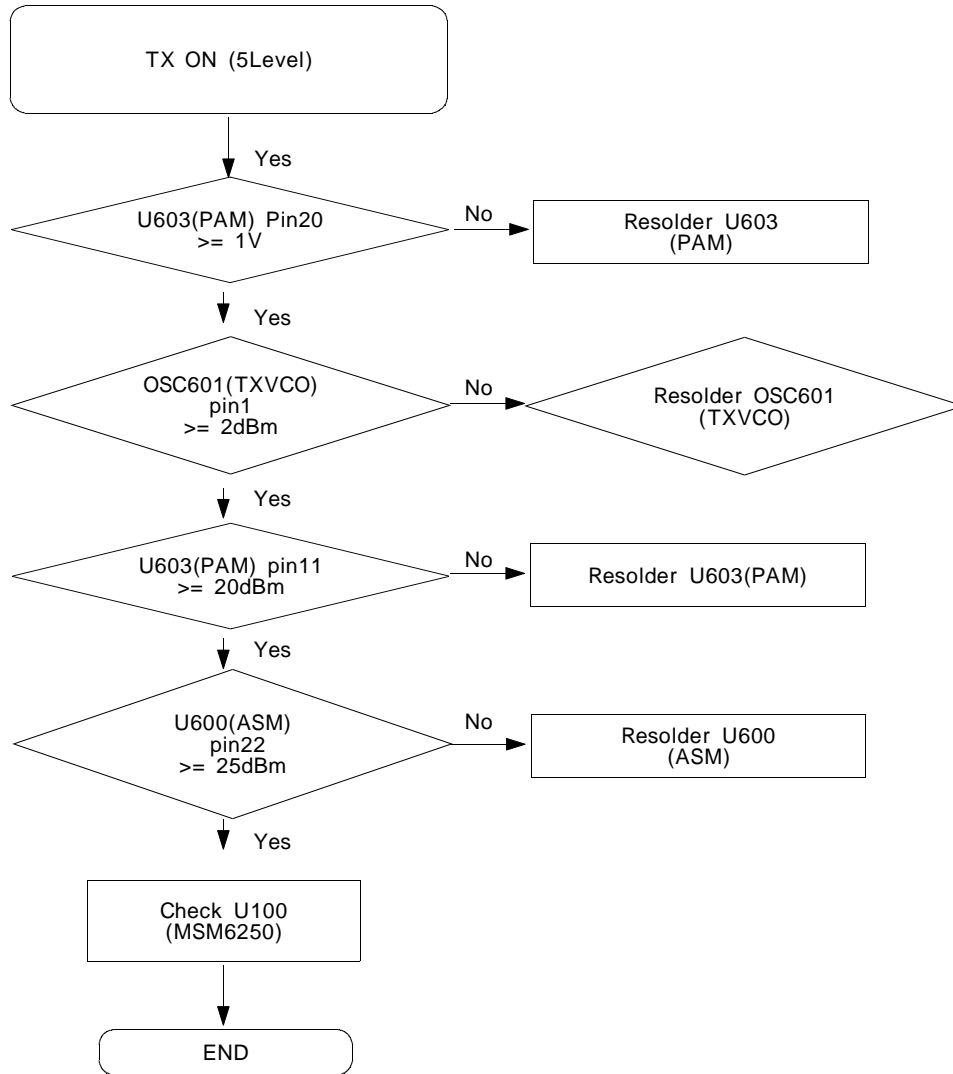

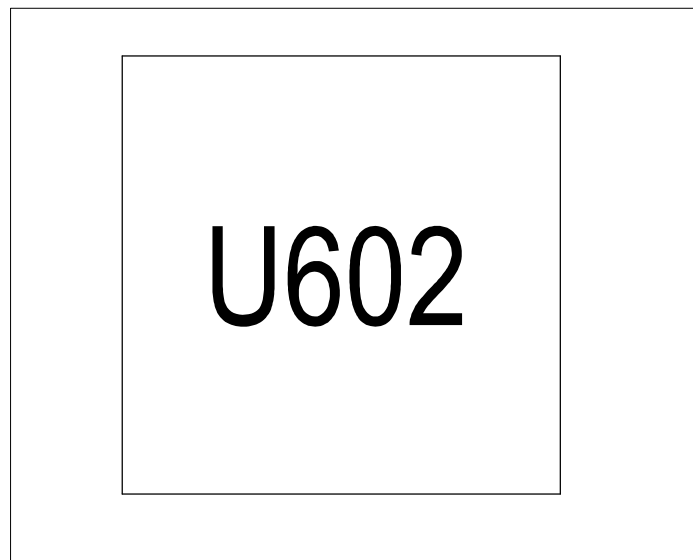
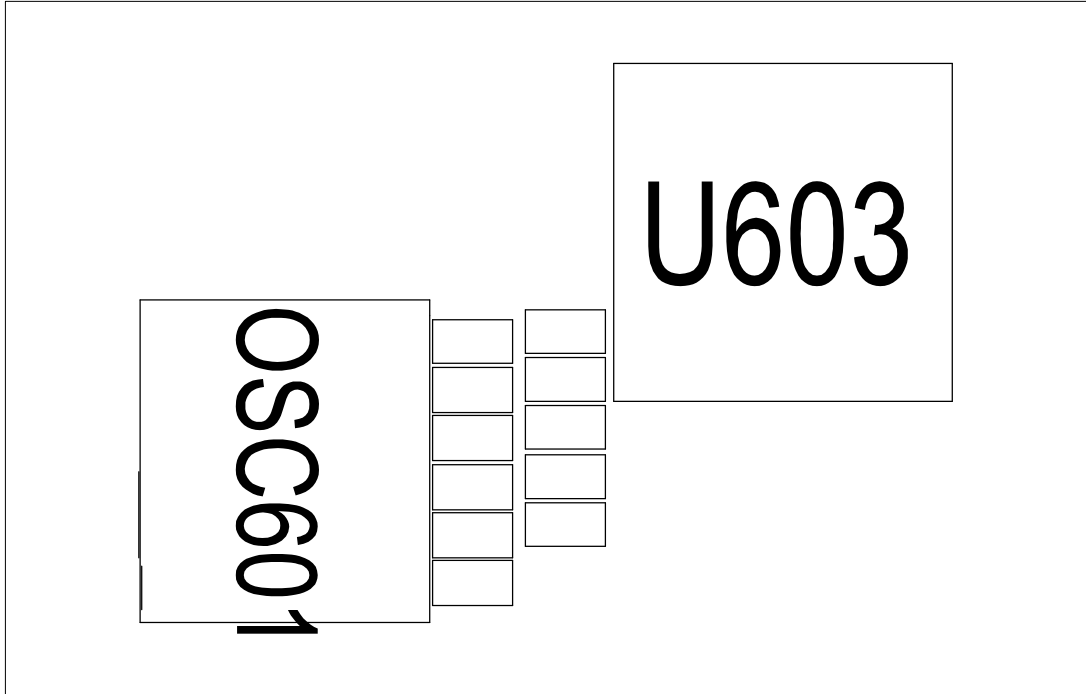

7-13. DCS Receiver

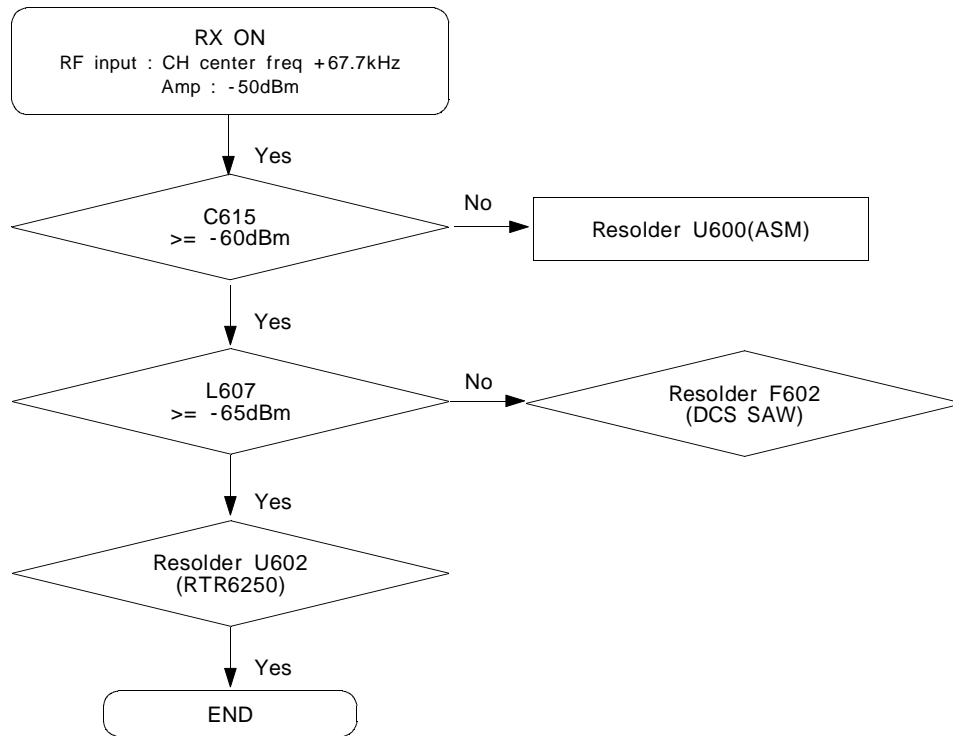

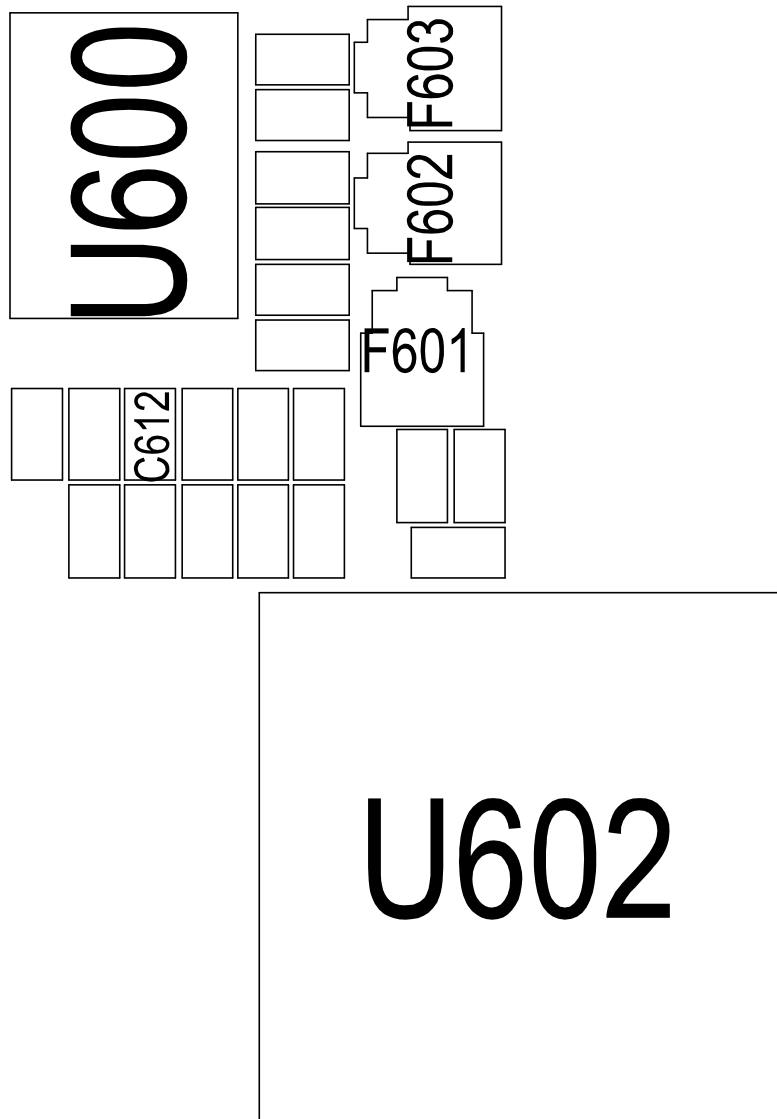

7-14. DCS Transmitter

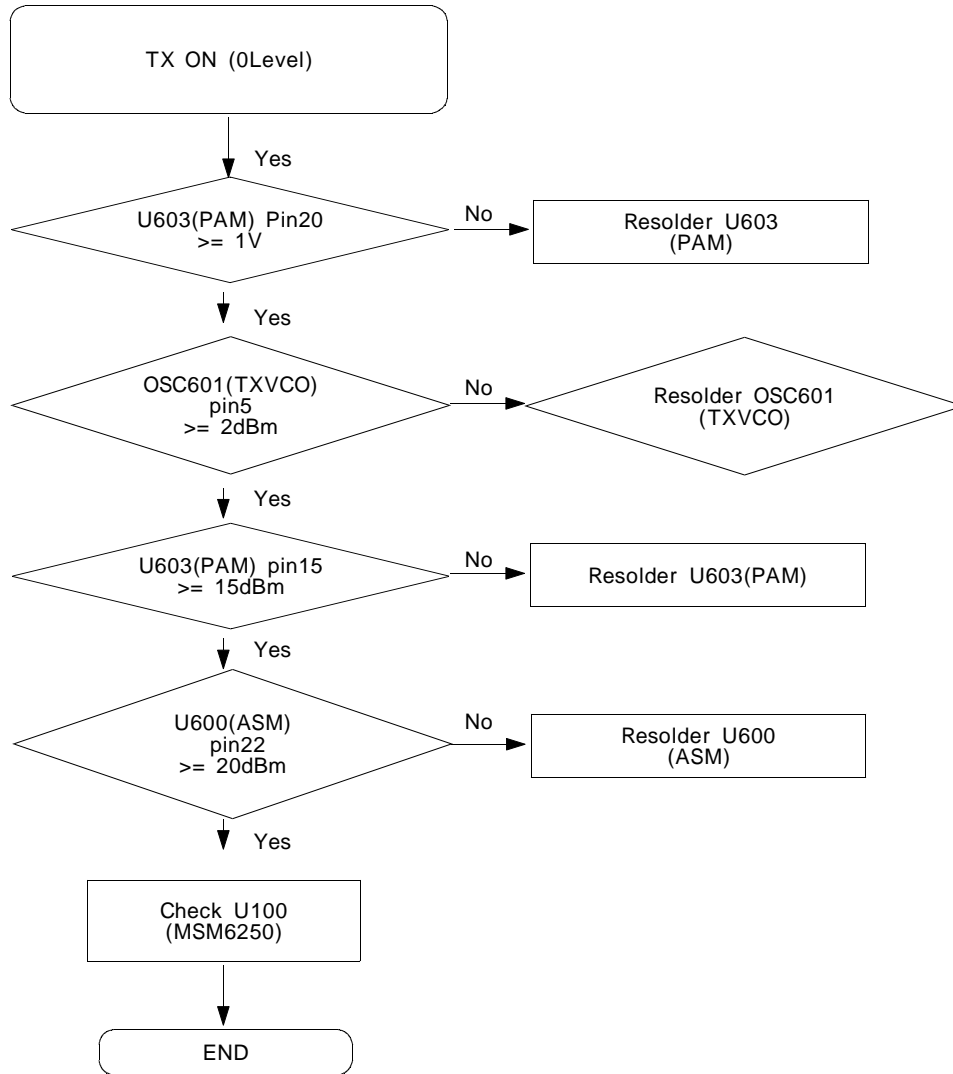

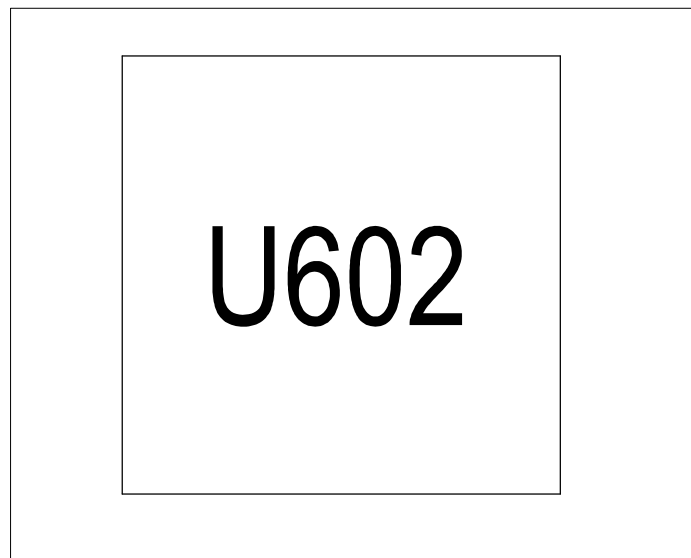
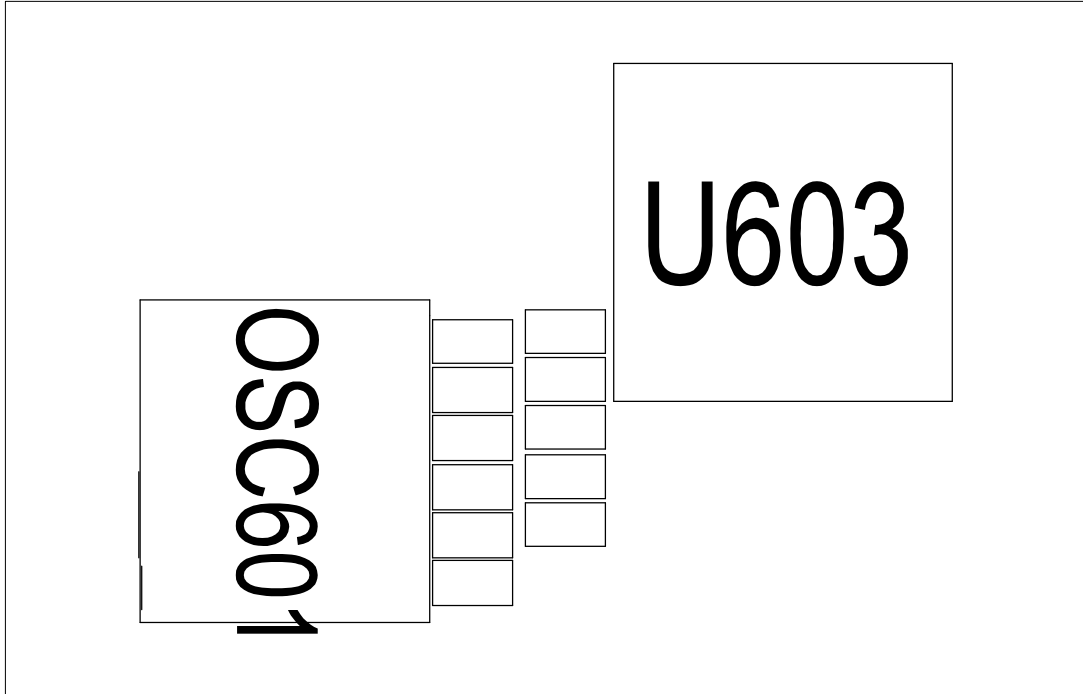

7-15. PCS Receiver

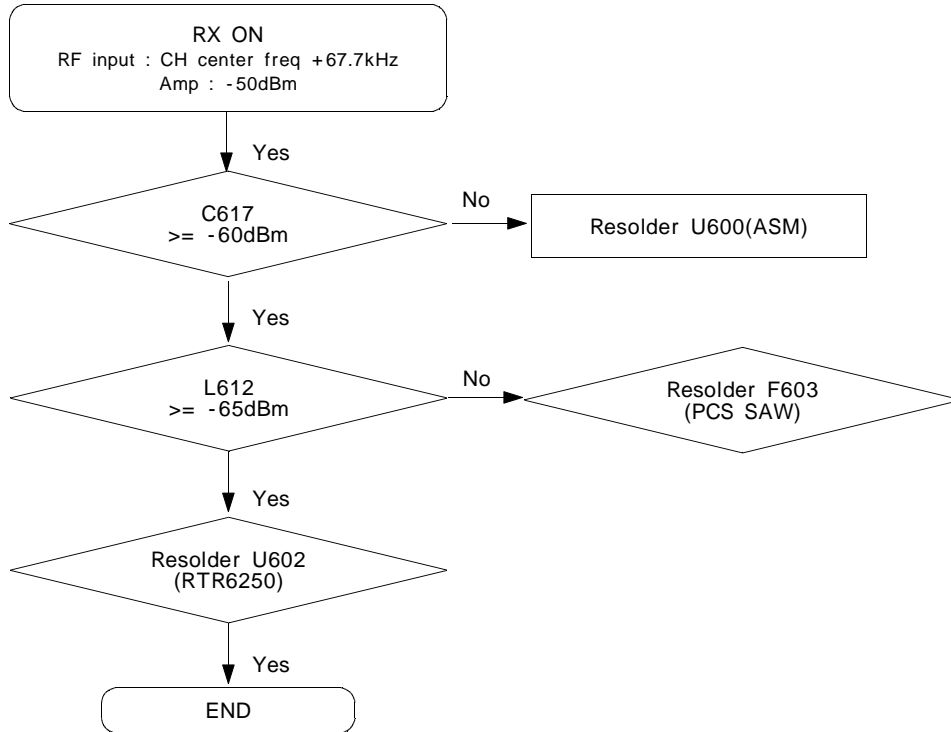

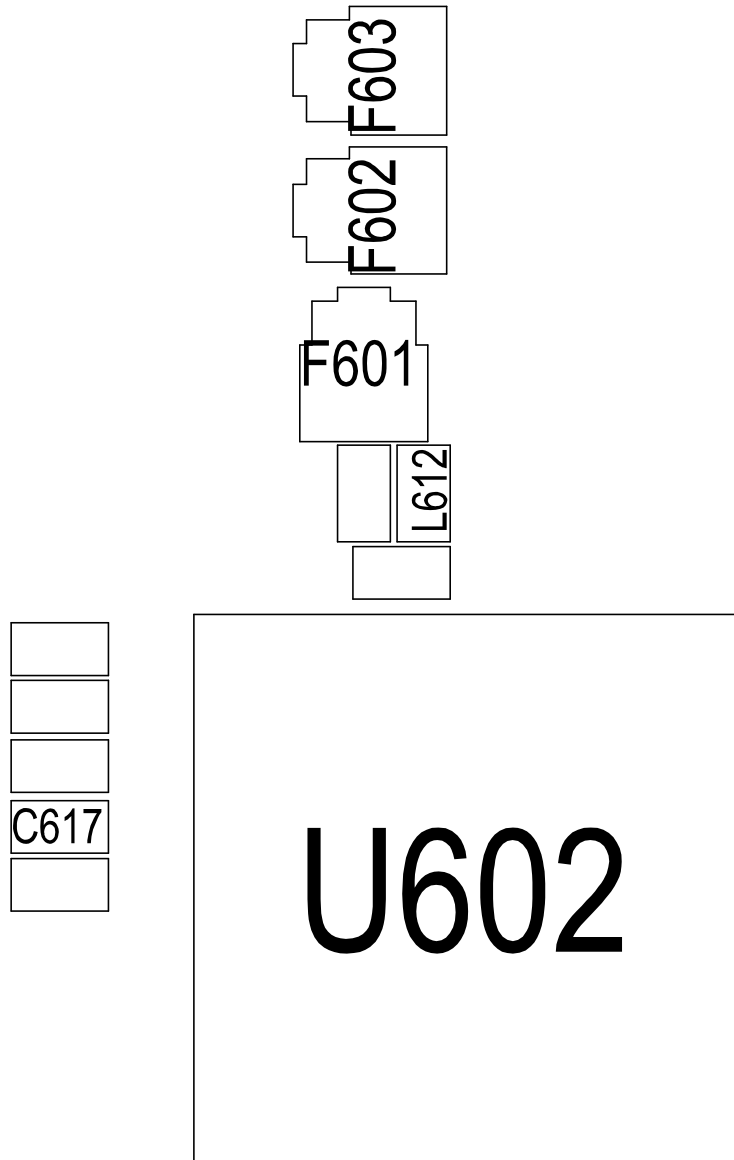

7-16. PCS Transmitter

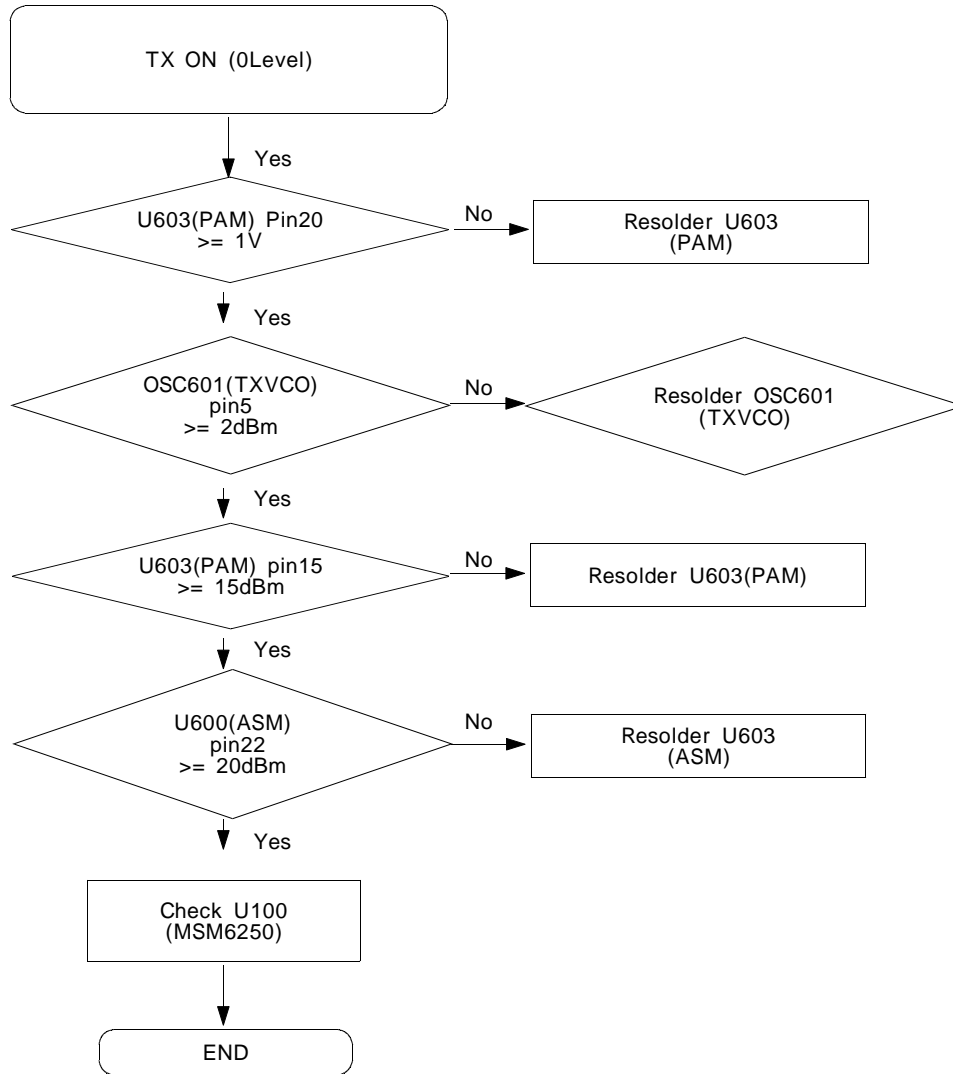

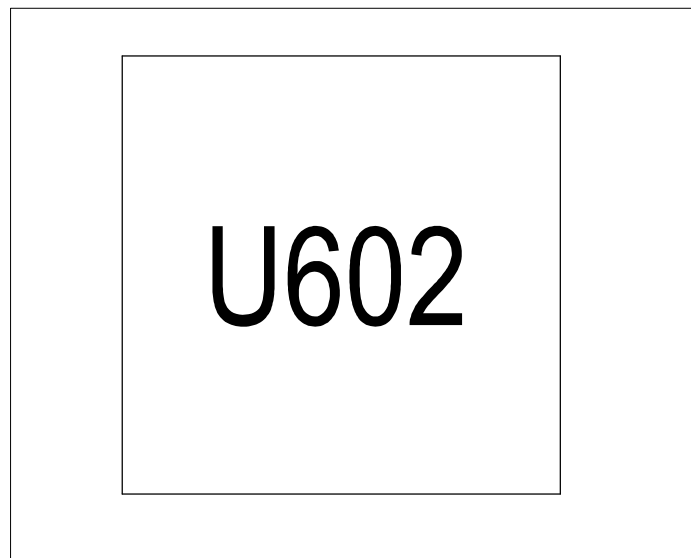
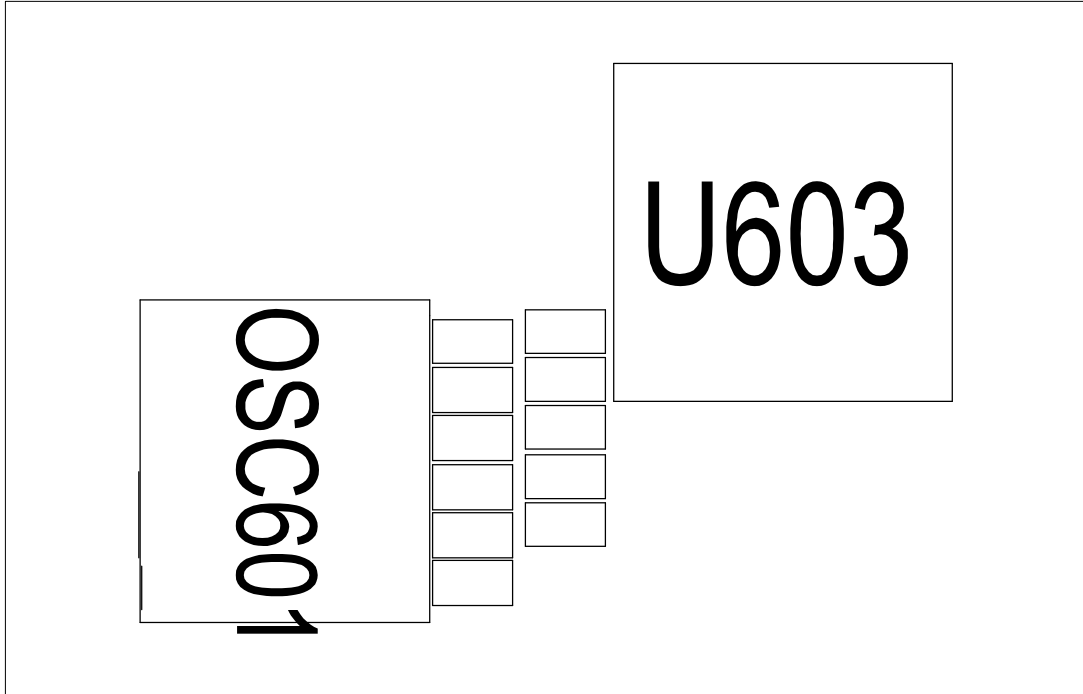

7-17. WCDMA Receiver

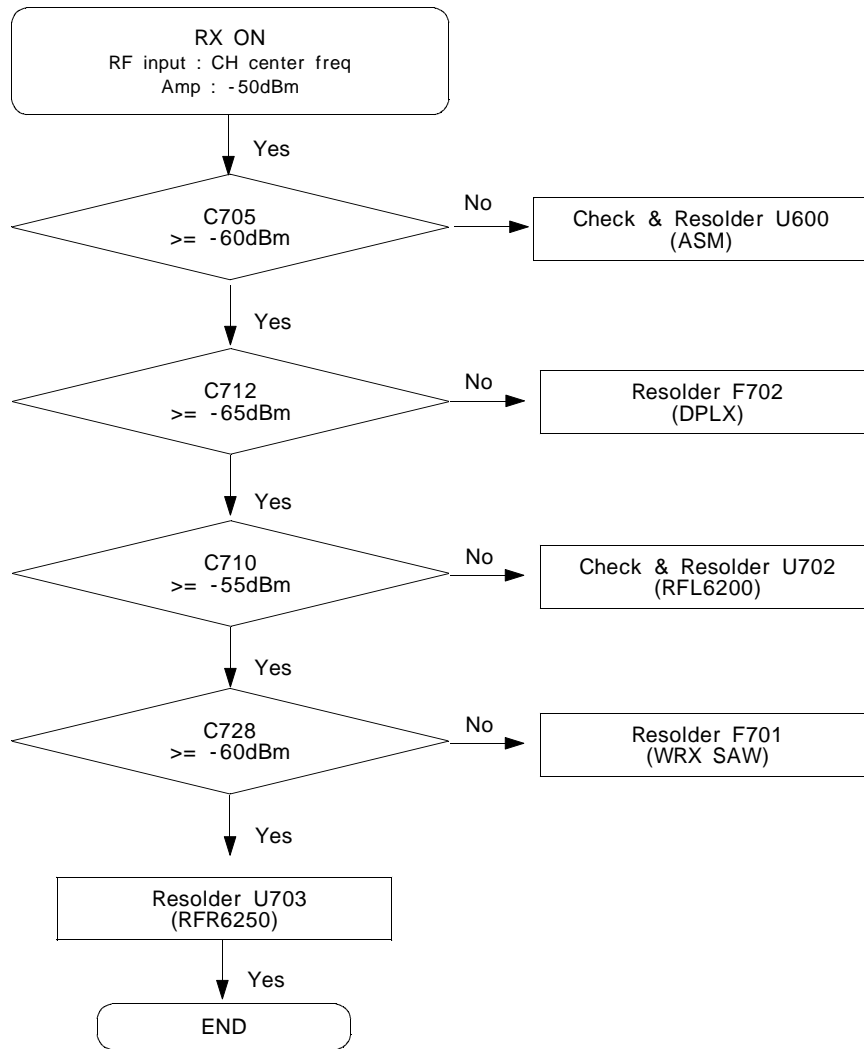

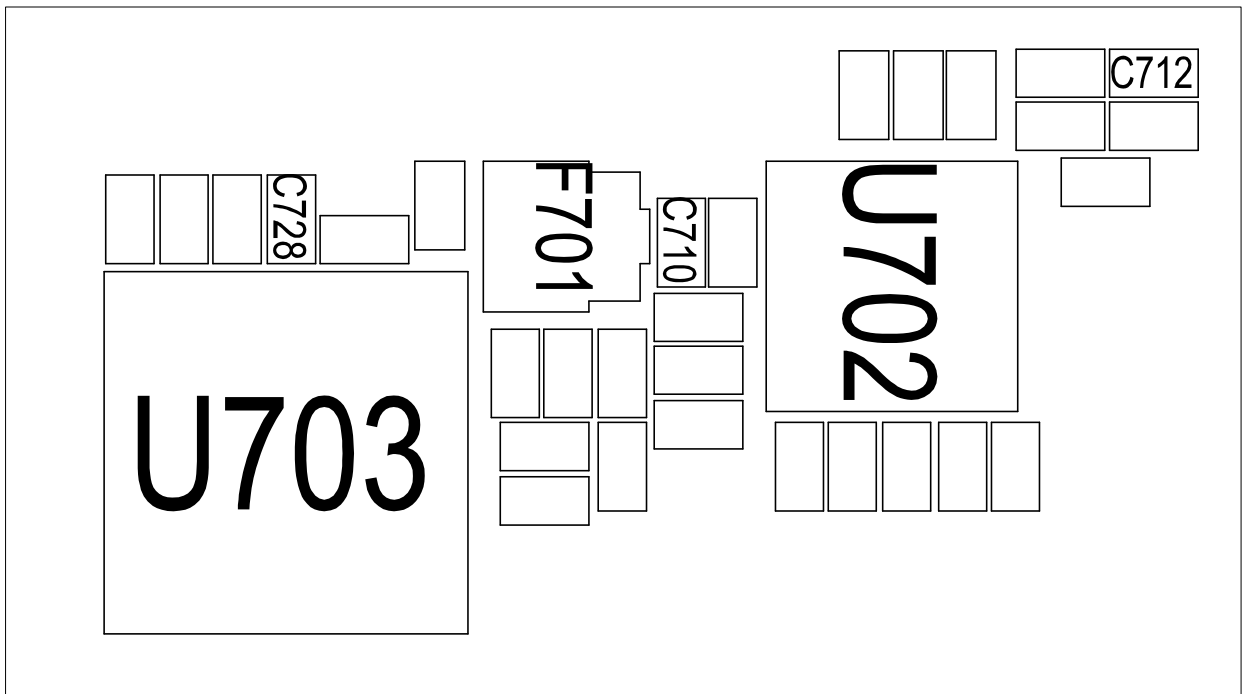
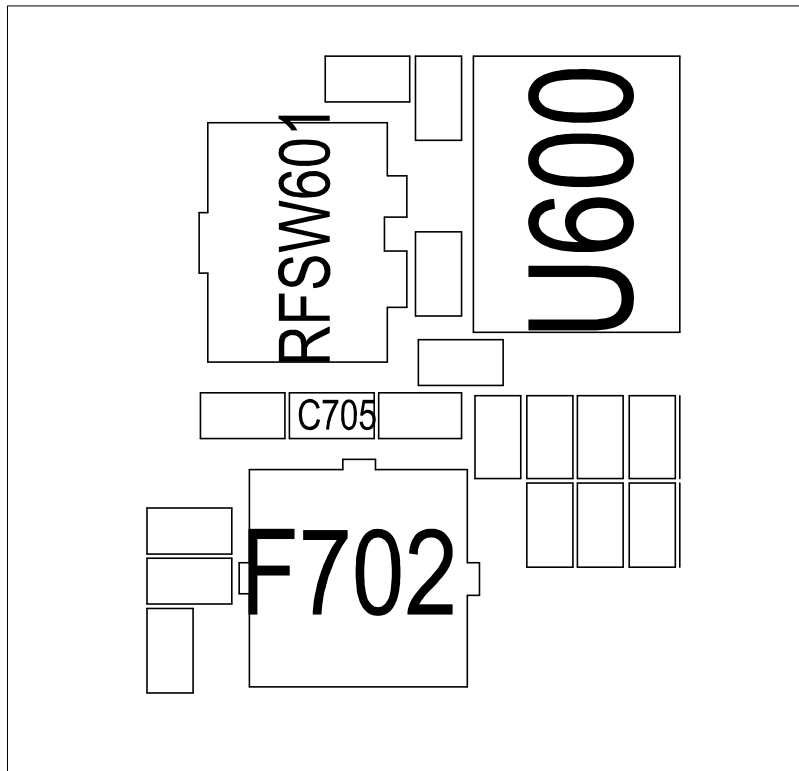

7-18. WCDMA Transmitter

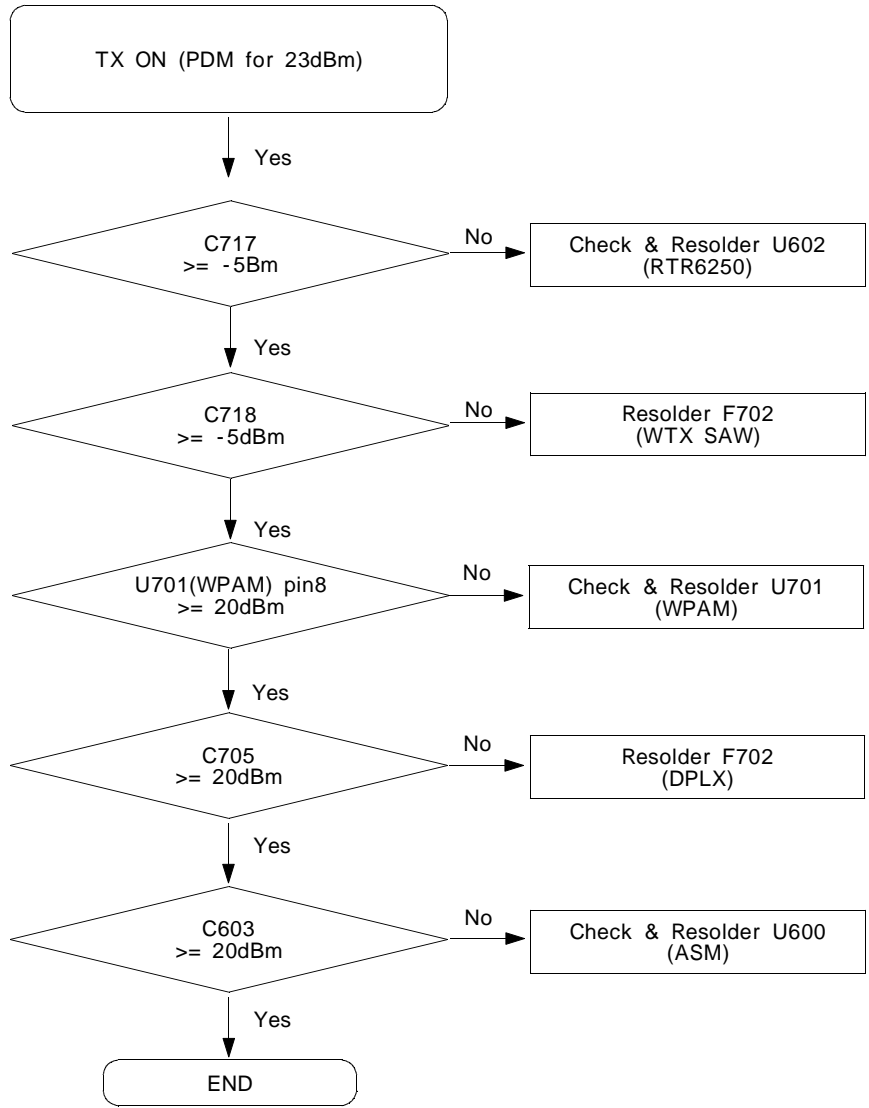

Transmitter

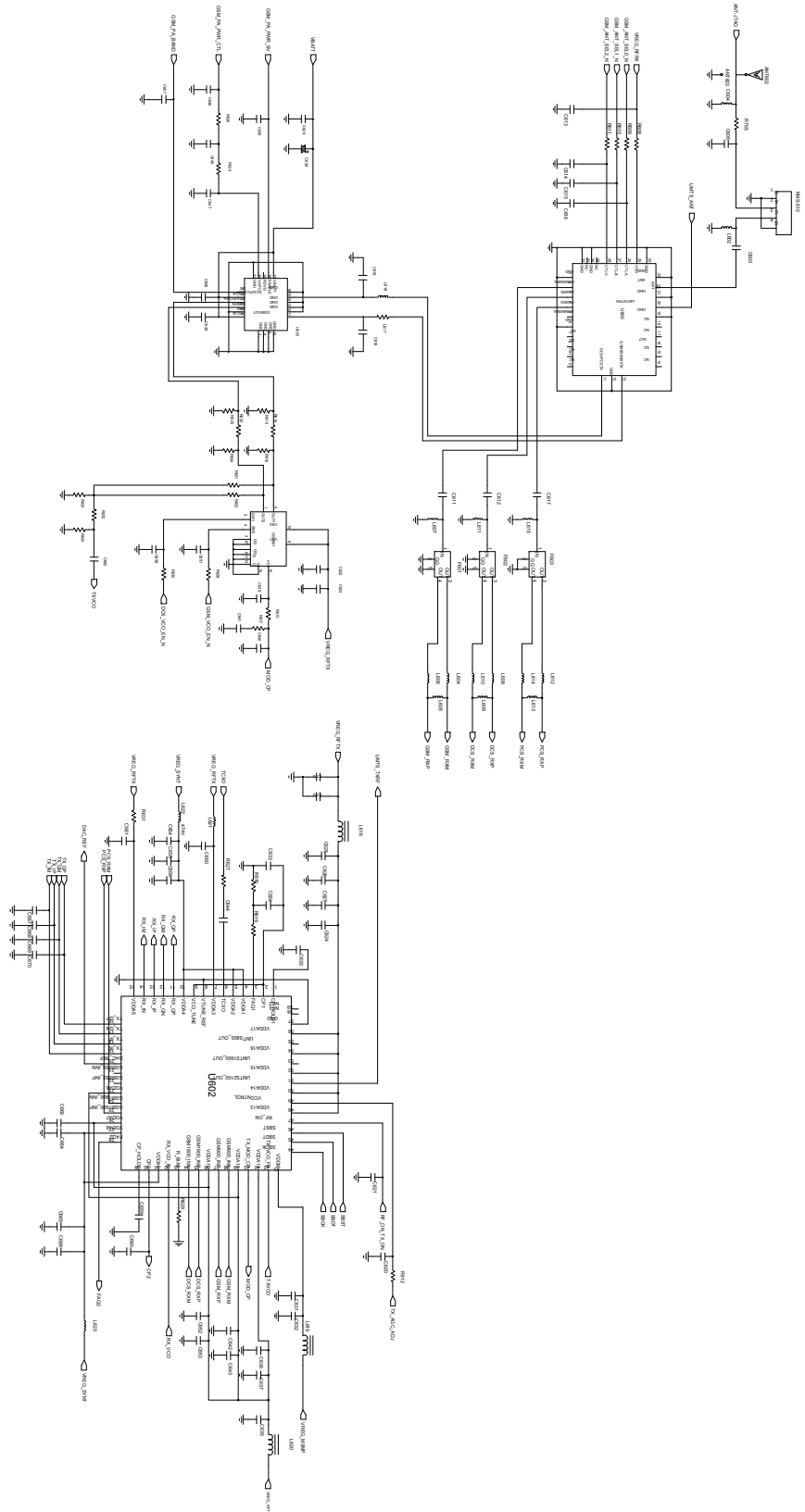

WCDMA Part

