

**SAMSUNG**

UMTS TELEPHONE  
SGH-Z105

# ***SERVICE*** *Manual*

**UMTS TELEPHONE**



**CONTENTS**

1. Specification
2. Circuit Description
3. Exploded Views and Parts List
4. Electrical Parts List
5. Block Diagrams
6. PCB Diagrams
7. Flow Chart of Troubleshooting

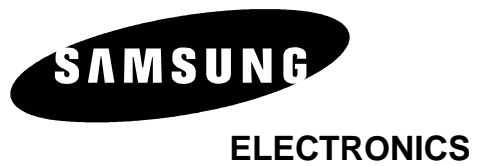

This Service Manual is a property of Samsung Electronics Co.,Ltd.  
Any unauthorized use of Manual can be punished under applicable  
International and/or domestic law.

Samsung Electronics Co.,Ltd. April. 2004  
Printed in Korea.

Code No.: GH68-05056A  
BASIC.

---

# 1. SGH-Z105 Specification

---

## 1. GSM General Specification

	GSM900 Phase 1	EGSM 900 Phase 2	DCS1800 Phase 1
Freq. Band[MHz] Uplink/Downlink	890~915 935~960	880~915 925~960	1710~1785 1805~1880
ARFCN range	1~124	0~124 & 975~1023	512~885
Tx/Rx spacing	45MHz	45MHz	95MHz
Mod. Bit rate/ Bit Period	270.833kbps 3.692us	270.833kbps 3.692us	270.833kbps 3.692us
Time Slot Period/Frame Period	576.9us 4.615ms	576.9us 4.615ms	576.9us 4.615ms
Modulation	0.3GMSK	0.3GMSK	0.3GMSK
MS Power	33dBm~13dBm	33dBm~5dBm	30dBm~0dBm
Power Class	5pcl ~ 15pcl	5pcl ~ 19pcl	0pcl ~ 15pcl
Sensitivity	-102dBm	-102dBm	-100dBm
TDMA Mux	8	8	8
Cell Radius	35Km	35Km	2Km

## 2. GSM TX power class

TX Power control level	GSM900
5	33 ±2 dBm
6	31 ±2 dBm
7	29 ±2 dBm
8	27 ±2 dBm
9	25 ±2 dBm
10	23 ±2 dBm
11	21 ±2 dBm
12	19 ±2 dBm
13	17 ±2 dBm
14	15 ±2 dBm
15	13 ±2 dBm
16	11 ±3 dBm
17	9 ±3dBm
18	7 ±3 dBm
19	5 ±3 dBm

TX Power control level	DCS1800
0	30 ±3 dBm
1	28 ±3 dBm
2	26 ±3 dBm
3	24 ±3 dBm
4	22 ±3 dBm
5	20 ±3 dBm
6	18 ±3 dBm
7	16 ±3 dBm
8	14 ±3 dBm
9	12 ±4 dBm
10	10 ±4 dBm
11	8 ±4dBm
12	6 ±4 dBm
13	4 ±4 dBm
14	2 ±5 dBm
15	0 ±5 dBm

---

## 2. SGH-Z105 Circuit Description

---

### 1. SGH-Z105 RF Circuit Description

#### 1. Antenna Switch Module (U100)

The antenna switch module allows multiple operating bands and modes to share the same antenna. A common antenna connects to one of five paths: 1) UMTS-2100 Rx/Tx, 2) EGSM-900 Rx, 3) EGSM-900 Tx, 4) DCS-1800 Rx, and 5) DCS-1800 Tx. UMTS operation requires simultaneous reception and transmission.

#### 2. Filter

To convert Electromagnetic Field Wave to Acoustic Wave and then pass the specific frequency band.

- GSM Rx FILTER (F101) For filtering the frequency band between 925 ~ 960 MHz.
- DCS Rx FILTER (F100) For filtering the frequency band 1805 and 1880 MHz.
- WCDMA Rx FILTER (F201) For filtering the frequency band 2110 and 2170 MHz.
- WCDMA Tx FILTER (F202) For filtering the frequency band 1920 and 1980 MHz.

#### 3. TCVCXO (OSC202)

To generate the 19.2MHz reference clock to drive the logic and RF.

#### 4. Duplexer (F203)

A duplexer splits a single operating band into receive and transmit paths.

#### 5. Isolator (MIS201)

An isolator between the Power Amplifier and the duplexer is highly recommended to provide constant load and source impedances (respectively) to those devices.

#### 6. UMTS PAM (U202)

This is a key component in the transmitter chain and must complement the RTR6200 IC precisely; jointly they dominate the UMTS transmitter performance characteristics. Parameters such as gain, output power level, ACLR, harmonics, Rx-band noise, and power supply current are critical.

#### 7. GSM/DCS PAM (U102)

The PAM is a key component in any transmitter chain and must complement the rest of the transmitter precisely. For GSM and DCS operation, the closed-loop transmit power control functions add even more requirements relative to the UMTS PA. In addition to gain control and switching requirements, the usual RF parameters such as gain, output power level, several output spectrum requirements, and power supply current are critical.

#### 8. GSM/DCS Dual Tx VCO (OSC101)

The dual Tx VCO outputs, one for EGSM and one for DCS, drive a resistive network that splits the active signal into two signals: 1) the input to the active PAM – this is the low loss path, and 2) the OPLL feedback signal.

#### 9. Dual VCO (OSC201)

The dual-band UHF VCO is a key component within its phase-locked loop; VCO performance directly impacts PLL and transceiver performance. GSM/DCS Rx/Tx LO & UMTS Rx LO signal is generated from this dual VCO's output.

10. RFL6200 (U201)

The RFL6200 includes an LNA circuit optimized for UMTS-2100 operation. The LNA is separated from all other receive functions contained within the RFR6200 receiver IC to improve mixer LO to RF isolation – a critical parameter in the Zero-IF architecture.

11. RFR6200 (U205)

The RFR6200 provides the Zero-IF receiver signal path, from RF to analog baseband, for UMTS-2100 applications. The RFR6200 accepts its UMTS input signal from the handset RF front-end design. The UMTS input is configured differentially to optimize second-order inter-modulation and common mode rejection performance, and implements MSM-controlled gain adjustments to extend the receiver dynamic range.

12. RTR6200 (U101)

The RTR6200 supports multi-band, multi-mode phones with two receiver signal paths and three transmitter signal paths:

1) Receiver paths

- EGSM-900
- DCS-1800

2) Transmitter paths

- EGSM-900 (using OPLL technique)
- DCS-1800 (using OPLL technique)
- UMTS-2100

Numerous secondary functions are integrated on-chip as well:

3) Phase-locked loop circuits

- PLL#1 and an on-chip VCO supports UMTS Tx
- PLL#2 and an external VCO supports EGSM Rx and Tx, DCS Rx and Tx, and UMTS Rx

4) Transceiver LO generation and distribution circuits

- EGSM-900 Rx and Tx
- DCS-1800 Rx and Tx
- UMTS-2100 Tx

---

## 2. Baseband Circuit description of SGH-Z105

### 1. PM6050

#### 1.1. Power Management

Ten low-dropout regulators designed specifically for GSM applications power the terminal and help ensure optimal system performance and long battery life. It provides seven LDO support for 2.6V, 2.8V while a self-resetting, electronically fused switch supplies power to external accessories. Ancillary support functions, such as RTC module and RTC charger, Clock Buffer, aid in reducing both board area and system complexity.

SBI BUS serial interface provides access to control and configuration registers. This interface gives full control of the MSM6200 and enables system designers to maximize both standby and talk times.

Supervisory functions, including a reset generator, an input voltage monitor, and a ADC Converter support reliable system design. These functions work together to ensure proper system behavior during start-up or in the event of a fault condition (low microprocessor voltage, insufficient battery energy, or excessive die temperature).

#### 1.2. Keypad Backlight

The Keypad backlight driver output is at pin 17 (KEYBD\_DRV) and is designed to drive parallel connected LEDs directly. Its output current level is SBI-programmable and meets the performance specified below.

Input parameters are not specified since they are internal.

#### 1.3. TCXO Controller and Buffers

The PM6050 IC includes circuits for controlling the TCXO warm-up and buffering its signal for distribution throughout the handset. Performance specifications are presented below.

## 2. Connector

### 2-1. LCD Connector

LCD is consisted of main LCD (color 262K TFT LCD) and small LCD (color 65K LCD). Chip select signals in the U302, LCD\_CS1- can enable small LCD. W\_LED\_ON signal enables white LED of main LCD, EN\_EN signal enables EL of small LCD.

"RESET-, TFT\_RESET\_N" signal initiates the Reset process of the LCD.

8-bit data lines (AD(0)~AD(7)) transfers data and commands to Small LCD through by pass capacitor. Data and commands use "RS" signal. If this signal is high, Inputs to LCD are commands. If it is low, Inputs to LCD are data. The signal which informs the input or output state to LCD, is required. But this system is not necessary this signal.

Power signals for LCD are "VDD\_LP" and "2.8LV". "SPK+" and "SPK-" from U533 are used for audio speaker. And "Vibrator" from Q702 enables the motor.

## 2-2. Key

This is consisted of key interface pins among U302, KEYSENSE\_N(0:4). These signals compose the matrix. Result of matrix informs the key status to key interface in the U302. Power on/off key is separated from the matrix. So power on/off signal is connected with U302 to enable U601. twelve key LED use the "VBAT" supply voltage. "KEY\_LED\_ON" signal enables LEDs with current control. "HALL\_SW" informs the status of folder (open or closed) to the. This uses the hall effect IC, A3210ELH. A magnet under main LCD enables A3210ELH.

## 2-3. EMI ESD Filter

This system uses the EMI ESD filter, SMF05 to protect noise from IF CONNECTOR part.

## 2-4. IF connetor

It is 24-pin connector. They are designed to use VBATT, CF, M\_TXD0, M\_RXD0, RTS, CTS, JIG\_ON, HFK\_DETECT, M\_RXD0, M\_TXD0, HFK\_MIC+, HFK\_MIC-, HFK\_SPK+, HFK\_SPK- and GND. They connected to power supply IC, microprocessor and signal processor IC.

## 3. Audio

EAR1OP and EAR1ON from U302 are connected to the main speaker. AUXOP and AUXON are connected to the Hands free kit. MIC\_P and MIC\_N are connected to the main MIC. And EAR\_MIC1P and EAR\_MIC1N are connected to the Earphone.

YMU762MA3 is a LSI for portable telephone that is capable of playing high quality music by utilizing FM synthesizer and ADPCM decoder that are included in this device.

As a synthesis, YMU762MA3 is equipped 32 voices with different tones. Since the device is capable of simultaneously generating up to synchronous with the play of the FM synthesizer, various sampled voices can be used as sound effects.

Since the play data of YMU762MA3 are interpreted at anytime through data bus, the length of the data(playing period) is not limited, so the device can flexibly support application such as incoming call melody music distribution service.

The hardware sequence built in this device allows playing of the complex music without giving excessive load to the CPU of the portable telephones. Moreover, the registers of the FM synthesizer can be operated directly for real time sound generation, allowing, for example, utilization of various sound effects when using the game software installed in the portable telephone.

YMU762 includes a speaker amplifier with high ripple removal rate whose maximum output is 550mW (SPVDD=3.6V). For the headphone, it is provided with a stereophonic output terminal.

## 4. Memory

The signals in the MSM6200 enable two memories. They use only one volt supply voltage, VDD\_LP from the PM6050. This system uses AMD's memory, AM50DL128BG. It is consisted of 128M bits flash NOR memory and 32M bits SRAM memory. It has 16 bit data line, AD[0~15] which is connected to MSM6200. It has 22 bit address lines, A[1~22]. ROM\_CS and RAM\_CS signals is chip select.

In the multi-media processor, it has three type memories. One is 256Mbit Nor Flash memory another is 256Mbit NAND Flash memory and the other is 128Mbit SDRAM memory. Multi-media processor doesn't have a NAND memory interface. But we make a software algorithm use for NAND memory.



## 5. Multi-media processor MA55133

MA55133 is an LSI, which is designed on 3GPP 3G-324M Standard for a video telephone system. Since protocol software is external, MA55133 can run with another protocol like H.323 by changing its software. Because of small power consumption - Typ.140mW and very small package - FPBGA, it is suitable to use 3G-324M LSI for portable apparatus.

### Feature

- Based on 3GPP 3G-324M standard
- Video MPEG-4 (simple profile level1) or H263 (baseline)
- Audio AMR, G723.1, MP3 or AAC (program downloadable)
- Multiplexing H.223 (Level 0, 1, 2, processed by CPU with assistant hardware)
- Control H.245 (Processed all by CPU)
- Built-in 32bit RISC CPU(ARM7TDMI) for control, including H.245 and H.223
- Built-in 16bit DSP for audio CODEC
- Built-in SD card I/F
- Video input Rec601 YUV = 4:2:2, 8 bit I/F
- Video output Rec601 YUV = 4:2:2(8bit) / RGB 18bit
- Built-in Picture-In-Picture Image Displaying Functions
- Built-in On Screen Display(OSD) Functions
- Video CODEC 15fps for both encode and decode in QCIF size is possible.
- Program on SDRAM is executable without ROM (optional).
- Power supply VDDI=2.0V to 2.7V (internal), VDDO=2.7 to 3.6V (I/O)

## 6. Camera (OM6802)

The OM6802 is a highly integrated compact CMOS color camera module with embedded Camera Signal Processor (CSP) that supports up to VGA resolution formats in a small package including a focused optical system. It uses Philips See MOSTM technology for high sensitivity and low noise. The device is programmable via an I2C serial interface. The CIR656 compliant YUV output stream enables easy integration into mobile phones or PDAs.

### 3. SGH-Z105 Exploded View and its Parts list

#### 1. Cellular phone Exploded View

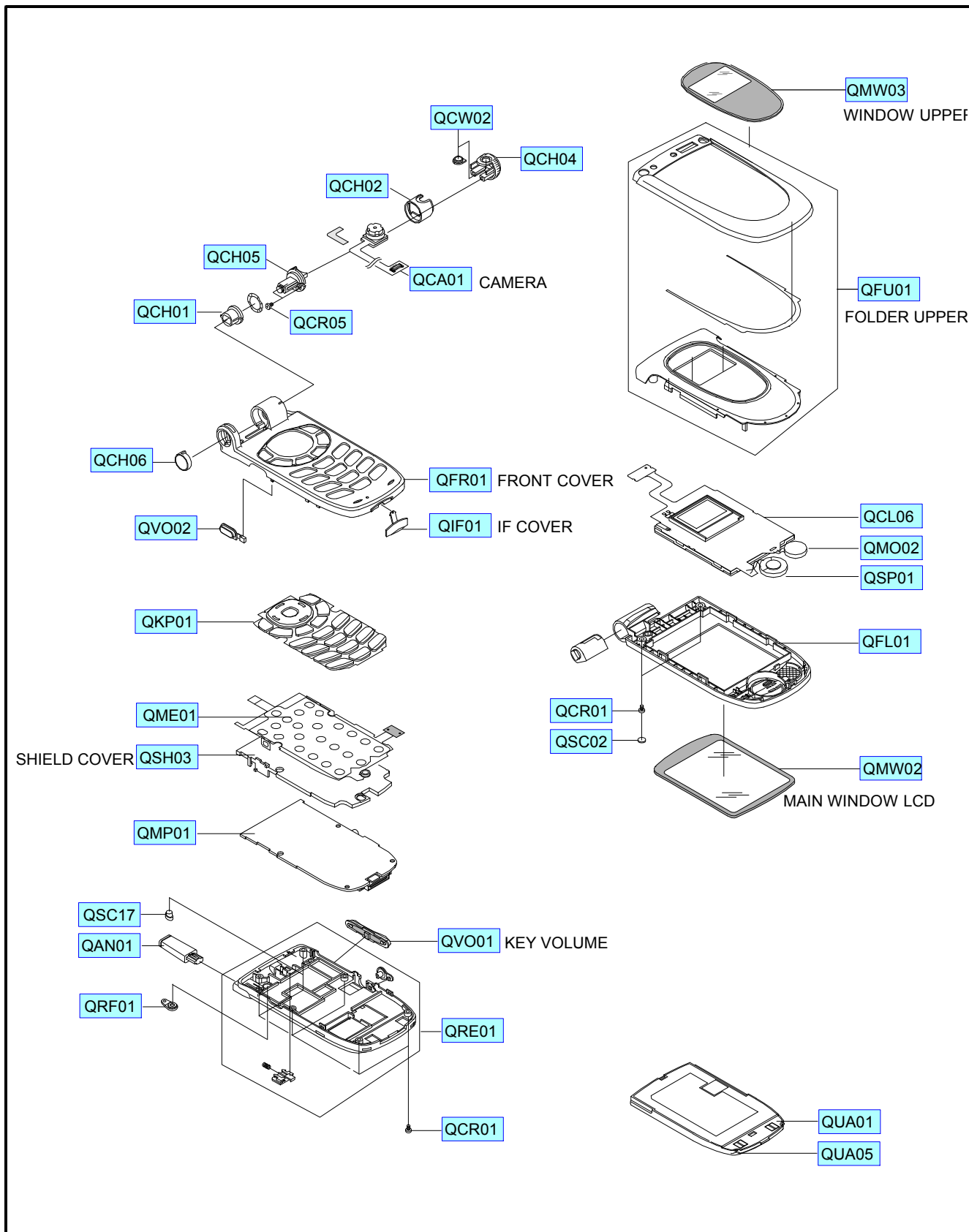

## 2. Cellular phone Parts list

Location NO.	Description	SEC CODE	Remark
QMW03	PCT-WINDOW UPPER	GH72-12157A	
QFU01	FOLDER UPPER	GH75-04201A	
QCL06	LCD	GH07-00527A	
QMO02	MOTOR	3101-001341	
QSP01	SPEAKER	3001-001532	
QFL01	FOLDER LOWER	GH75-04202A	
QMW02	WINDOW MIAN	GH72-12158A	
QCR07	SCREW	6001-001691	
QSC02	SCREW CAP	GH74-07557A	
QCH04	CAMERA COVER	GH71-02131A	
QCW02	CAMERA WINDOW	GH72-09666A	
QCH02	CAMERA HOUSING	GH72-12966A	
QCA01	CAMERA	GH96-01500A	
QCH05	CAMERA SHAFT	GH71-02656B	
QCR05	SCREW	6001-001478	
QCH01	CAMERA HINGE DUMMY	GH72-11107A	
QCH06	FRONT SIDE DUMMY	GH75-04646A	
QVO02	KEY REJECT	GH75-04237A	
QFR01	FRONT COVER	GH75-04203A	
QIF01	IF COVER	GH72-12149A	
QKP01	KEYPAD	GH75-04205A	
QME01	METAL DOME	GH59-01273A	
QSH03	SHIELD COVER	GH72-12147A	
QMP01	PBA MAIN	GH92-01703A	
QSC17	REAR SCREW CAP	GH72-12151A	
QAN01	ANTENNA	GH42-00391A	
QRF01	RF COVER	GH72-12150A	
QRE01	REAR COVER	GH75-04204A	
QVO01	KEY VOLUME	GH75-04236A	
QCR07	SCREW	6001-001691	
QBA01	BATTERY	GH43-01279A	
QBA05	BATTERY	GH43-01280A	

3. Test Jig (GH80-03305A)

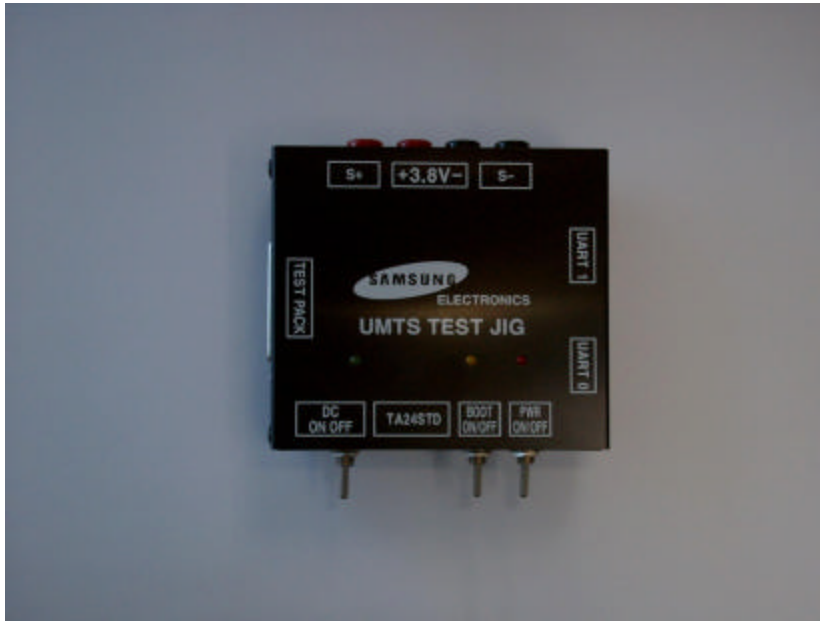

3-1. RF Test Cable  
(GH39-00105A)



3-2. Test Cable  
(GH39-00210A)



3-3. Serial Cable



3-4. Power Supply Cable



3-5. DATA CABLE  
(GH39-00208A)



3-6. TC  
(GH44-00482A)



## 4. SGH-Z105 MAIN Electrical Parts List

SEC Code	Design LOC
0403-001427	ZD806
0403-001427	ZD807
0406-001084	D502
0406-001084	U513
0406-001084	ZD802
0406-001084	ZD803
0406-001084	ZD804
0406-001084	ZD808
0406-001084	ZD809
0406-001084	ZD810
0406-001178	ZD701
0406-001178	ZD801
0406-001178	ZD805
0407-001002	D601
0407-001002	D602
0407-001002	D603
0407-001002	D702
0407-001038	U704
0501-000162	Q702
0501-000218	Q703
0501-000218	Q706
0504-000168	Q601
0504-000168	Q705
0504-001060	U203
0504-001113	Q202
0505-001131	Q201
0505-001131	Q701
0505-001332	U301
0505-001454	Q704
0505-001570	U304
0505-001570	U604
0505-001570	U708
0505-001570	U710
1001-001183	U533
1001-001183	U546
1001-001183	U703
1001-001225	U100

SEC Code	Design LOC
1001-001231	U527
1001-001253	U547
1105-001489	U403
1109-001234	U401
1109-001243	U303
1201-001954	U102
1201-001984	U201
1201-001990	U202
1202-001036	U503
1203-002113	U606
1203-002965	U707
1203-003007	U601
1203-003137	U603
1203-003137	U607
1203-003137	U608
1203-003326	U204
1204-002018	U402
1204-002161	U510
1205-002293	U509
1205-002295	U302
1205-002297	U205
1205-002300	U101
1205-002514	U705
1404-001224	TH301
1405-001018	V801
1405-001082	V802
2007-000138	R105
2007-000138	R111
2007-000138	R117
2007-000138	R125
2007-000138	R130
2007-000138	R131
2007-000138	R203
2007-000138	R220
2007-000138	R226
2007-000138	R332
2007-000138	R405

SEC Code	Design LOC
2007-000138	R805
2007-000138	R806
2007-000138	R808
2007-000139	R115
2007-000139	R116
2007-000139	R122
2007-000139	R123
2007-000140	R103
2007-000140	R134
2007-000140	R229
2007-000140	R334
2007-000141	R102
2007-000142	R706
2007-000143	R411
2007-000143	R827
2007-000144	R137
2007-000147	R133
2007-000148	R124
2007-000148	R132
2007-000148	R205
2007-000148	R210
2007-000148	R211
2007-000148	R212
2007-000148	R301
2007-000148	R304
2007-000148	R311
2007-000148	R312
2007-000148	R324
2007-000148	R327
2007-000148	R403
2007-000148	R603
2007-000148	R604
2007-000148	R612
2007-000148	R618
2007-000148	R709
2007-000148	R826
2007-000148	R836

SEC Code	Design LOC
2007-000148	R837
2007-000148	U706
2007-000149	R335
2007-000152	R705
2007-000152	R707
2007-000152	R828
2007-000153	R317
2007-000153	R318
2007-000153	R401
2007-000153	R404
2007-000153	R414
2007-000153	R415
2007-000153	R516
2007-000157	R112
2007-000157	R224
2007-000157	R330
2007-000157	R412
2007-000157	R413
2007-000157	R420
2007-000157	R421
2007-000159	R840
2007-000159	R848
2007-000162	R407
2007-000162	R409
2007-000162	R410
2007-000162	R602
2007-000162	R704
2007-000163	R517
2007-000164	R624
2007-000166	R503
2007-000166	R838
2007-000168	R315
2007-000168	R623
2007-000170	R620
2007-000171	R101
2007-000171	R106
2007-000171	R107

SEC Code	Design LOC
2007-000171	R108
2007-000171	R109
2007-000171	R110
2007-000171	R113
2007-000171	R118
2007-000171	R128
2007-000171	R204
2007-000171	R206
2007-000171	R213
2007-000171	R216
2007-000171	R218
2007-000171	R230
2007-000171	R328
2007-000171	R329
2007-000171	R402
2007-000171	R406
2007-000171	R408
2007-000171	R416
2007-000171	R417
2007-000171	R418
2007-000171	R419
2007-000171	R504
2007-000171	R508
2007-000171	R509
2007-000171	R510
2007-000171	R512
2007-000171	R514
2007-000171	R606
2007-000171	R609
2007-000171	R622
2007-000171	R801
2007-000171	R802
2007-000171	R803
2007-000171	R804
2007-000171	R807
2007-000171	R809
2007-000171	R810

SEC Code	Design LOC
2007-000171	R812
2007-000171	R813
2007-000171	R819
2007-000171	R820
2007-000171	R821
2007-000171	R822
2007-000171	R823
2007-000171	R825
2007-000171	R830
2007-000171	R831
2007-000171	R832
2007-000171	R833
2007-000171	R834
2007-000171	R841
2007-000171	R843
2007-000171	R844
2007-000171	R845
2007-000171	R846
2007-000171	R849
2007-000171	R850
2007-000171	R851
2007-000171	R853
2007-000172	R138
2007-000172	R811
2007-000172	R814
2007-000172	R815
2007-000172	R816
2007-000172	R817
2007-000172	R818
2007-000173	R202
2007-000636	R621
2007-000775	R515
2007-000932	R331
2007-000982	R708
2007-001119	R305
2007-001119	R308
2007-001119	R336

SEC Code	Design LOC
2007-001217	R104
2007-001217	R126
2007-001217	R127
2007-001284	R223
2007-001290	R114
2007-001290	R119
2007-001291	R233
2007-001291	R234
2007-001298	R222
2007-001301	R121
2007-001305	R232
2007-001306	R120
2007-001313	R309
2007-001325	R140
2007-001325	R141
2007-001325	R142
2007-001325	R513
2007-001339	R313
2007-001339	R316
2007-002796	R135
2007-002796	R422
2007-002796	R608
2007-002965	R221
2007-003006	R842
2007-007001	R225
2007-007014	R511
2007-007135	R323
2007-007138	R217
2007-007138	R219
2007-007142	R607
2007-007314	R201
2007-007314	R207
2007-007314	R209
2007-007314	R214
2007-007314	R325
2007-007318	R322
2007-007318	R506

SEC Code	Design LOC
2007-007318	R507
2007-007334	R502
2007-007489	R839
2007-007491	R136
2007-007491	R208
2007-007528	R306
2007-007528	R307
2007-007538	R321
2007-007538	R611
2007-007698	R228
2007-007981	R614
2007-008117	R227
2007-008401	R613
2203-000233	C124
2203-000233	C125
2203-000233	C126
2203-000233	C127
2203-000233	C148
2203-000233	C151
2203-000233	C201
2203-000233	C202
2203-000233	C204
2203-000233	C210
2203-000233	C221
2203-000233	C223
2203-000233	C226
2203-000233	C231
2203-000233	C236
2203-000233	C240
2203-000233	C242
2203-000233	C244
2203-000233	C247
2203-000233	C357
2203-000233	C358
2203-000233	C362
2203-000233	C364
2203-000233	C517



SEC Code	Design LOC
2203-000233	C618
2203-000233	C704
2203-000233	C810
2203-000254	C138
2203-000254	C143
2203-000254	C153
2203-000254	C224
2203-000254	C256
2203-000254	C258
2203-000254	C334
2203-000254	C335
2203-000254	C354
2203-000254	C355
2203-000254	C359
2203-000254	C361
2203-000254	C367
2203-000254	C368
2203-000254	C506
2203-000254	C530
2203-000254	C610
2203-000254	C847
2203-000254	C850
2203-000254	R231
2203-000278	C115
2203-000278	C135
2203-000278	C617
2203-000278	C621
2203-000278	C622
2203-000278	C628
2203-000278	C632
2203-000278	C633
2203-000278	C636
2203-000278	C637
2203-000278	C638
2203-000278	C639
2203-000278	C710
2203-000311	C120

SEC Code	Design LOC
2203-000330	C208
2203-000330	C211
2203-000330	C214
2203-000330	C245
2203-000386	C130
2203-000386	C137
2203-000386	C206
2203-000386	C255
2203-000386	C317
2203-000386	C319
2203-000386	C322
2203-000386	C325
2203-000386	C332
2203-000386	C333
2203-000386	C352
2203-000386	C510
2203-000386	C533
2203-000386	C543
2203-000386	C833
2203-000386	C834
2203-000386	C838
2203-000386	C843
2203-000386	C844
2203-000438	C105
2203-000438	C121
2203-000438	C132
2203-000438	C141
2203-000438	C159
2203-000438	C164
2203-000438	C205
2203-000438	C257
2203-000438	C260
2203-000438	C306
2203-000438	C311
2203-000438	C315
2203-000438	C407
2203-000438	C410

SEC Code	Design LOC
2203-000438	C536
2203-000489	C344
2203-000585	C237
2203-000585	C252
2203-000585	C416
2203-000585	C417
2203-000609	C123
2203-000628	C647
2203-000628	C658
2203-000628	C661
2203-000679	C106
2203-000679	C118
2203-000679	C146
2203-000679	C147
2203-000679	C250
2203-000679	C503
2203-000679	C505
2203-000679	C519
2203-000679	C521
2203-000679	C522
2203-000679	C811
2203-000679	C812
2203-000679	C831
2203-000714	C233
2203-000812	C101
2203-000812	C107
2203-000812	C109
2203-000812	C110
2203-000812	C112
2203-000812	C114
2203-000812	C116
2203-000812	C128
2203-000812	C133
2203-000812	C139
2203-000812	C160
2203-000812	C162
2203-000812	C166

SEC Code	Design LOC
2203-000812	C249
2203-000812	C801
2203-000812	C802
2203-000812	C803
2203-000812	C804
2203-000812	C805
2203-000812	C807
2203-000812	C809
2203-000812	C813
2203-000812	C814
2203-000812	C815
2203-000812	C816
2203-000812	C860
2203-000812	C861
2203-000812	C862
2203-000812	C863
2203-000812	C864
2203-000812	C865
2203-000854	C104
2203-000854	C150
2203-000854	C408
2203-000854	C411
2203-000885	C111
2203-000940	C363
2203-000940	C365
2203-000940	C654
2203-000995	C213
2203-000995	C326
2203-001124	C251
2203-001153	C713
2203-001178	C212
2203-001239	C142
2203-001383	C103
2203-001383	C219
2203-001405	C531
2203-001405	C542
2203-001432	C149

SEC Code	Design LOC
2203-001441	C547
2203-001598	C818
2203-002443	C155
2203-003054	C316
2203-003054	C318
2203-003054	C323
2203-003054	C327
2203-003054	C331
2203-003054	C338
2203-003054	C351
2203-003054	C502
2203-003054	C504
2203-003054	C511
2203-003054	C520
2203-003054	C523
2203-003054	C524
2203-003054	C535
2203-003054	C544
2203-003054	C806
2203-003054	C808
2203-003054	C835
2203-003054	C836
2203-003054	C837
2203-003054	C845
2203-003054	C846
2203-003054	C858
2203-003054	C859
2203-003054	C867
2203-003054	C868
2203-003054	C869
2203-005054	C145
2203-005056	C117
2203-005061	C301
2203-005061	C302
2203-005061	C303
2203-005061	C304
2203-005061	C307

SEC Code	Design LOC
2203-005061	C308
2203-005061	C309
2203-005061	C312
2203-005061	C313
2203-005061	C320
2203-005061	C324
2203-005061	C328
2203-005061	C336
2203-005061	C337
2203-005061	C339
2203-005061	C340
2203-005061	C343
2203-005061	C346
2203-005061	C347
2203-005061	C348
2203-005061	C349
2203-005061	C350
2203-005061	C366
2203-005061	C403
2203-005061	C404
2203-005061	C405
2203-005061	C406
2203-005061	C413
2203-005061	C414
2203-005061	C419
2203-005061	C501
2203-005061	C512
2203-005061	C513
2203-005061	C514
2203-005061	C525
2203-005061	C526
2203-005061	C532
2203-005061	C534
2203-005061	C537
2203-005061	C539
2203-005061	C541
2203-005061	C601

SEC Code	Design LOC
2203-005061	C602
2203-005061	C603
2203-005061	C604
2203-005061	C608
2203-005061	C642
2203-005061	C645
2203-005061	C652
2203-005061	C701
2203-005061	C830
2203-005061	C848
2203-005061	U709
2203-005234	C157
2203-005288	C230
2203-005288	C238
2203-005393	C329
2203-005393	C330
2203-005480	C508
2203-005482	C108
2203-005482	C113
2203-005482	C129
2203-005482	C131
2203-005482	C134
2203-005482	C136
2203-005482	C140
2203-005482	C152
2203-005482	C161
2203-005482	C163
2203-005482	C203
2203-005482	C222
2203-005482	C225
2203-005482	C234
2203-005482	C235
2203-005482	C239
2203-005482	C241
2203-005482	C243
2203-005482	C246
2203-005482	C254

SEC Code	Design LOC
2203-005482	C259
2203-005482	C345
2203-005482	C353
2203-005482	C356
2203-005482	C412
2203-005482	C415
2203-005482	C507
2203-005482	C548
2203-005482	C609
2203-005482	C615
2203-005482	C616
2203-005482	C703
2203-005482	C708
2203-005482	C711
2203-005482	C817
2203-005482	C819
2203-005482	C839
2203-005482	C840
2203-005482	C841
2203-005482	C866
2203-005496	C527
2203-005503	C156
2203-005571	C207
2203-005571	C227
2203-005664	C154
2203-005664	C641
2203-005664	C656
2203-005664	C659
2203-006053	C305
2203-006053	C310
2203-006053	C314
2203-006053	C705
2203-006053	C855
2203-006053	C856
2203-006090	C626
2203-006090	C644
2203-006090	C657

SEC Code	Design LOC
2203-006090	C660
2203-006093	C122
2203-006093	C611
2203-006093	C612
2203-006093	C613
2203-006093	C627
2203-006093	C634
2203-006093	C712
2203-006093	C849
2203-006201	C228
2203-006201	C623
2203-006201	C625
2203-006201	C631
2203-006201	C842
2203-006208	C229
2203-006208	C518
2203-006208	C528
2203-006208	C529
2203-006208	C629
2203-006208	C630
2203-006208	C635
2301-001197	C119
2301-001214	C253
2301-001659	C158
2404-001086	C248
2404-001086	C538
2404-001086	C540
2404-001086	C857
2404-001088	C643
2404-001105	C165
2404-001151	C321
2404-001239	C144
2404-001239	C341
2404-001239	C342
2404-001239	C515
2404-001239	C516
2404-001268	C614

SEC Code	Design LOC
2404-001268	C709
2404-001281	C605
2404-001281	C606
2404-001281	C607
2404-001281	C619
2404-001281	C653
2703-001229	L606
2703-001229	L608
2703-001229	L609
2703-001259	L211
2703-001595	L118
2703-001724	L101
2703-001729	L209
2703-001729	L210
2703-001733	L205
2703-001747	L204
2703-001750	L206
2703-001751	L203
2703-001786	L202
2703-002155	L201
2703-002155	L207
2703-002155	L212
2703-002198	C102
2703-002199	L108
2703-002199	L110
2703-002201	L117
2703-002203	L104
2703-002203	L106
2703-002207	L107
2703-002207	L109
2703-002208	L103
2703-002208	L105
2703-002314	L102
2703-002346	L208
2801-003856	OSC601
2802-001182	OSC301
2804-001528	U404

Electrical Parts List

---

SEC Code	Design LOC
2806-001310	OSC101
2806-001315	OSC201
2809-001280	OSC202
2901-001254	F103
2901-001286	F801
2901-001286	F802
2901-001286	F803
2901-001286	F804
2901-001286	F805
2901-001286	F806
2901-001286	F807
2901-001286	F808
2901-001286	F809
2904-001417	F101
2904-001419	F102
2904-001438	F202
2904-001439	F201
2909-001202	F203
3301-001158	L601
3301-001158	L602
3301-001341	L113
3301-001341	L119
3301-001341	L301
3301-001341	L302
3301-001341	L303
3301-001341	L603
3301-001341	L604
3301-001341	L605
3705-001255	RFSW100
3709-001298	CN701
3710-001587	CN803
3710-002037	CN802
3711-004112	CN801
3711-005200	CN804
3722-002096	CN501
4302-001119	BAT601
4709-001303	MIS201

SEC Code	Design LOC
GH41-00557A	

# 5. SGH-Z105 Block Diagrams

## 1. RF Solution Block Diagram

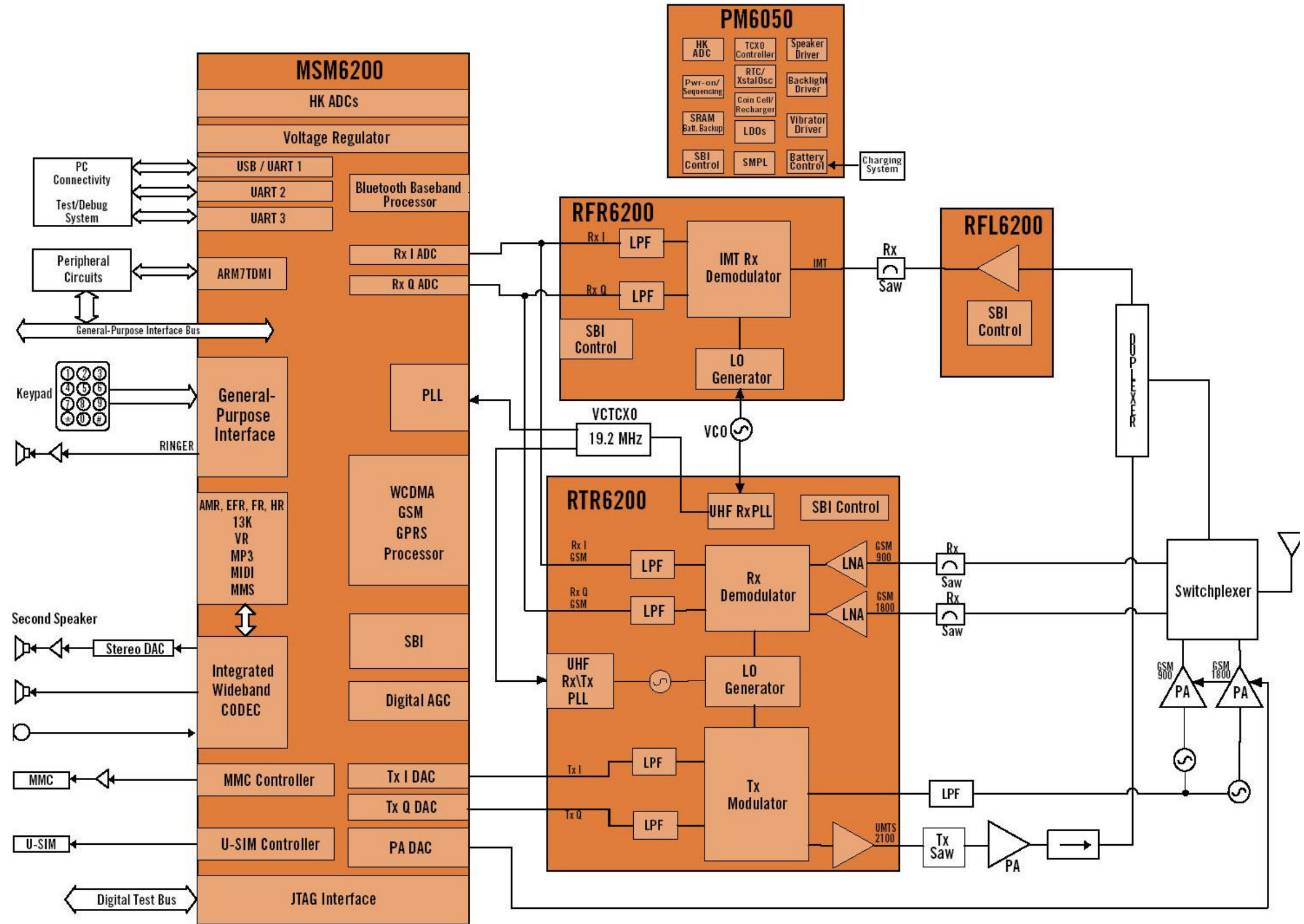

2. Base Band Solution Block Diagram

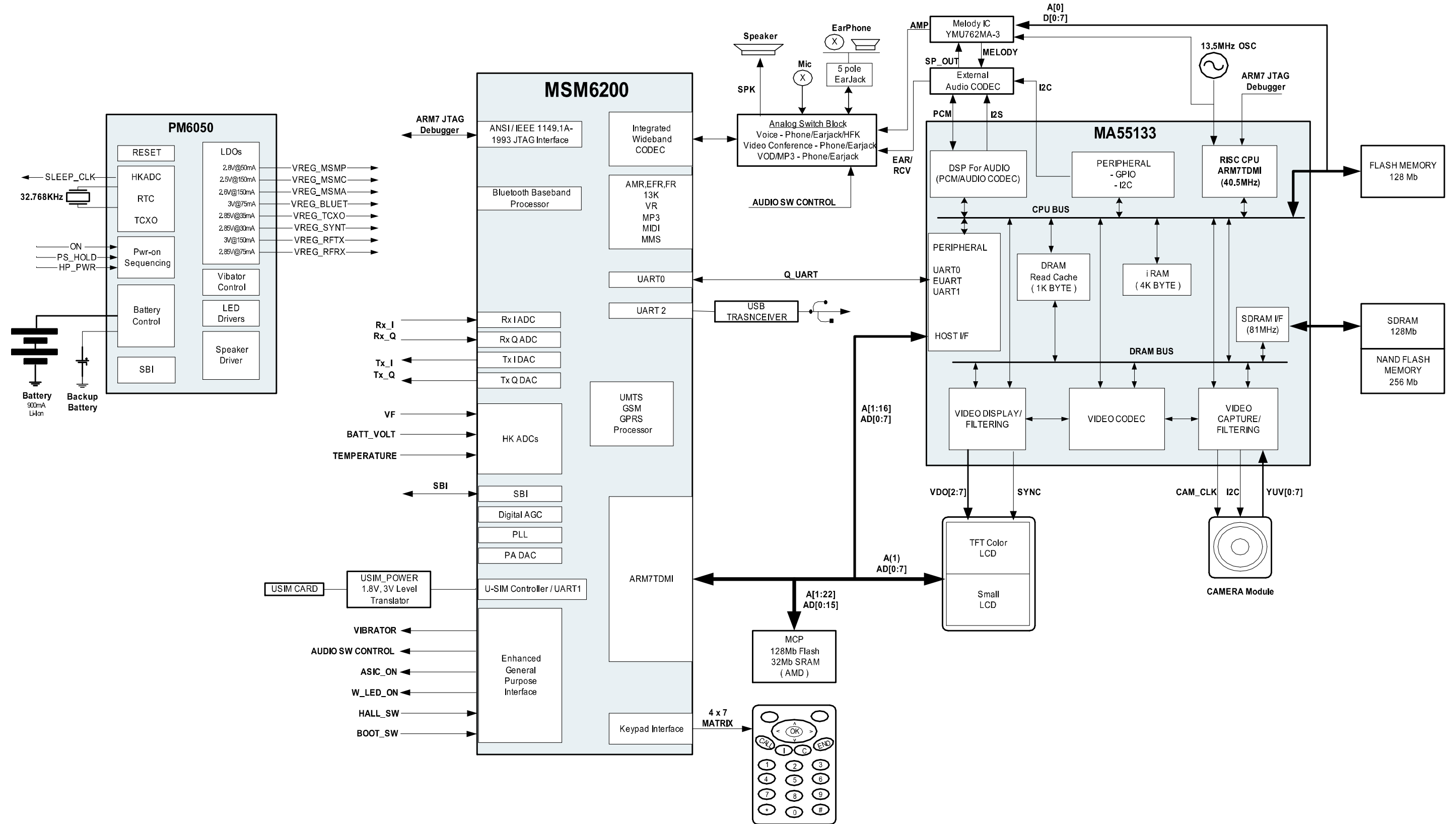



# 6. SGH-Z105 PCB Diagrams

## 1. Main PCB Top Diagram

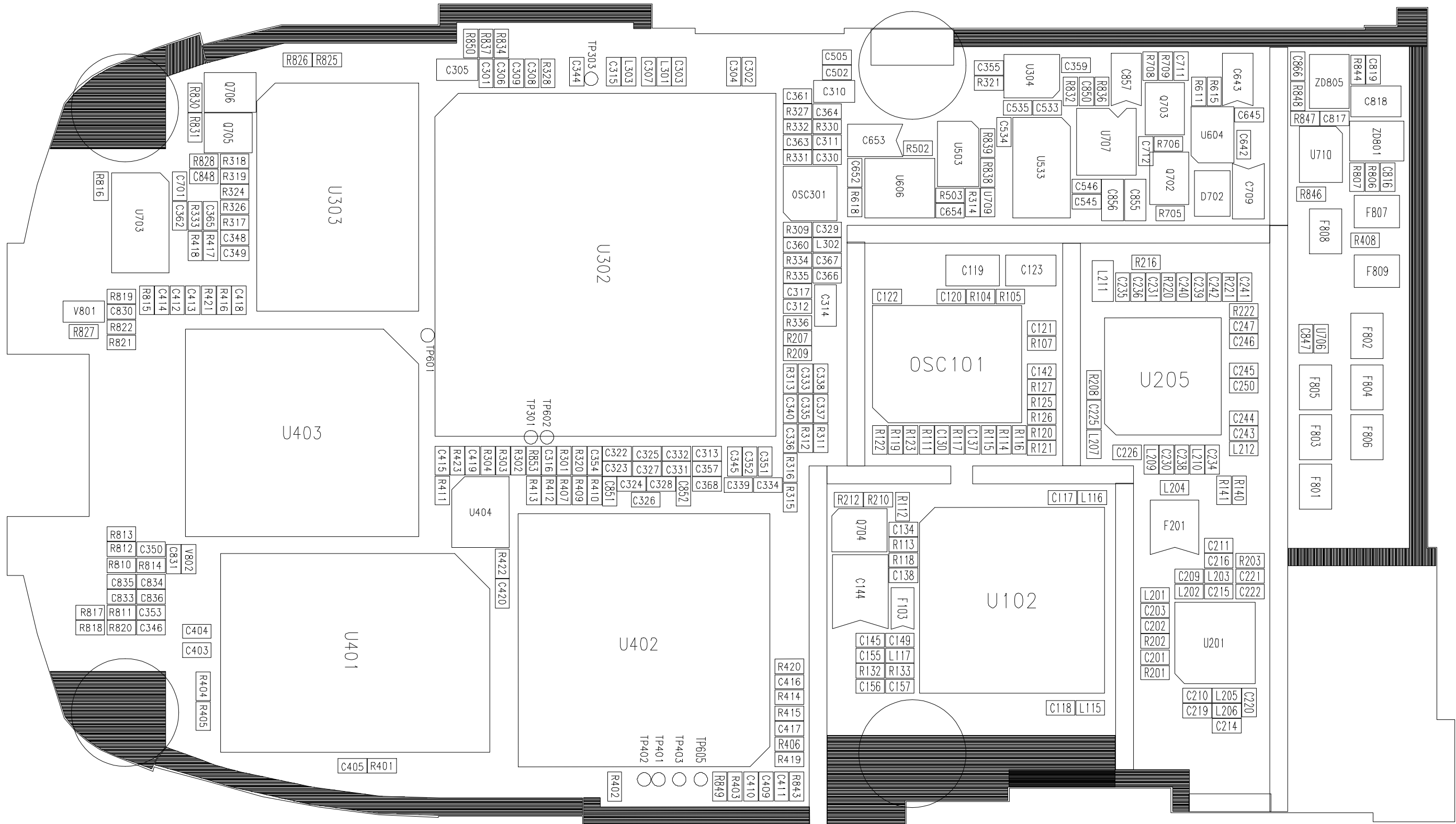

2. Main PCB Bottom Diagram



# 7. SGH-Z105 Flow Chart of Troubleshooting

## 1. Power On

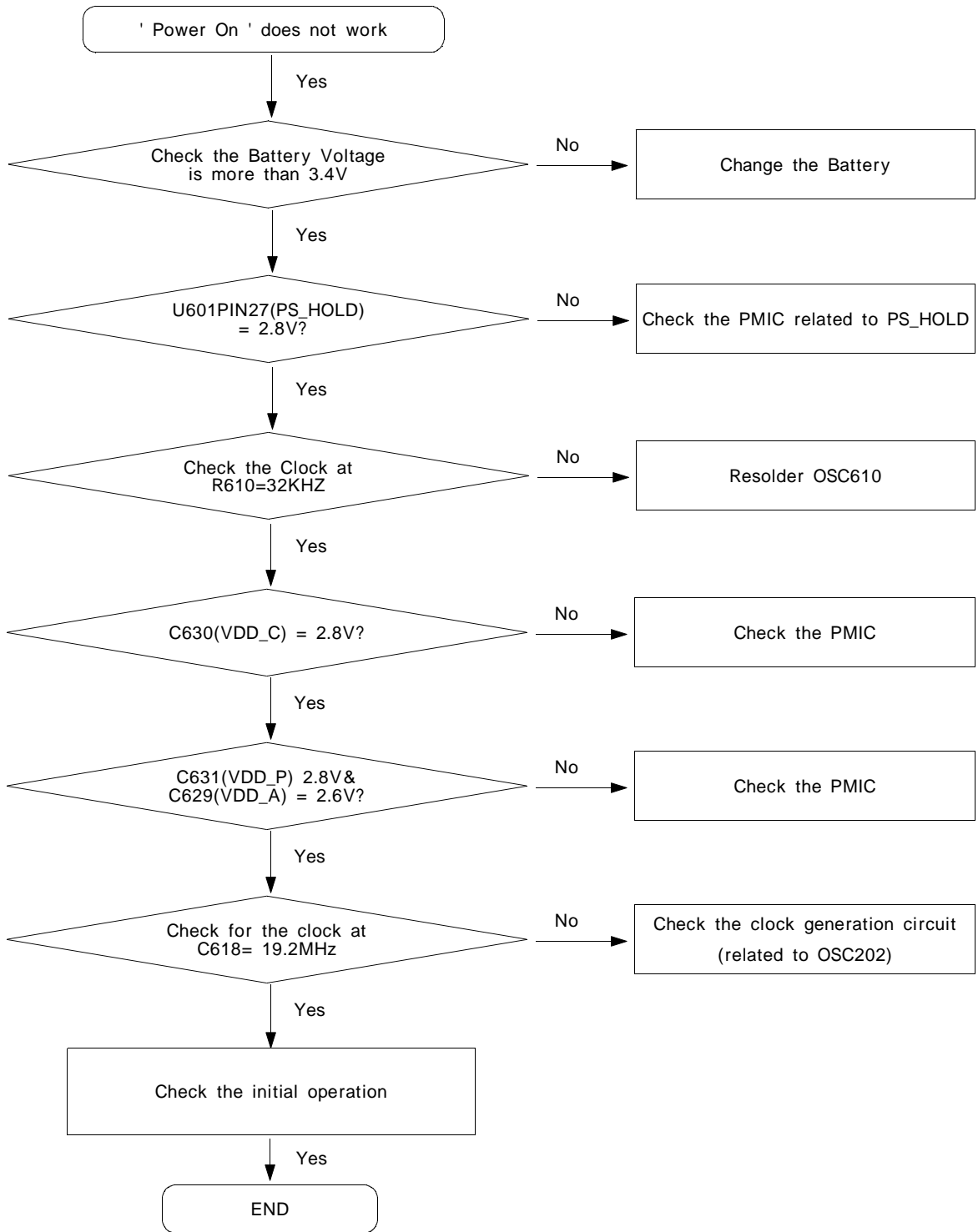

Power On

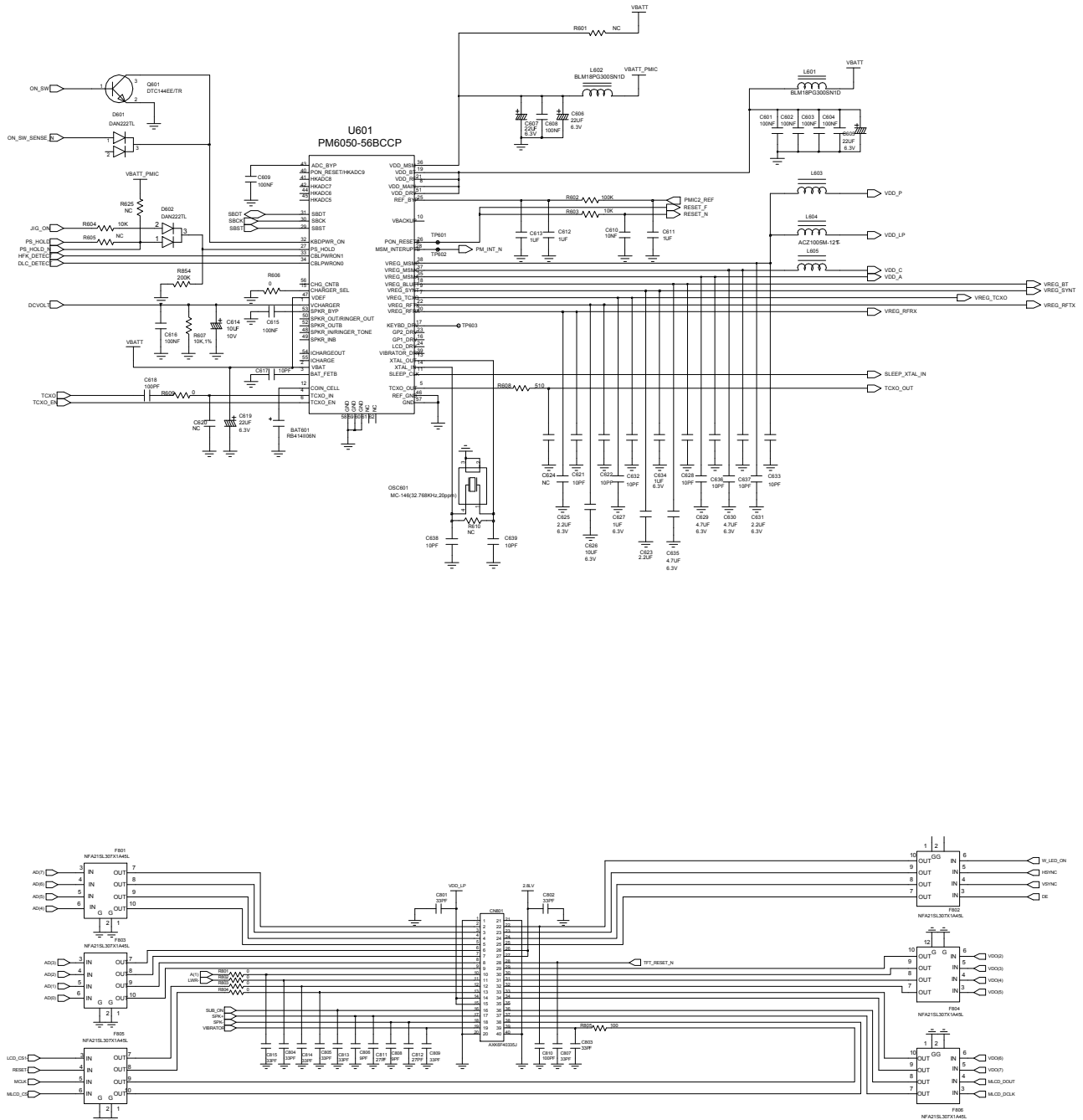

## 2. Initial

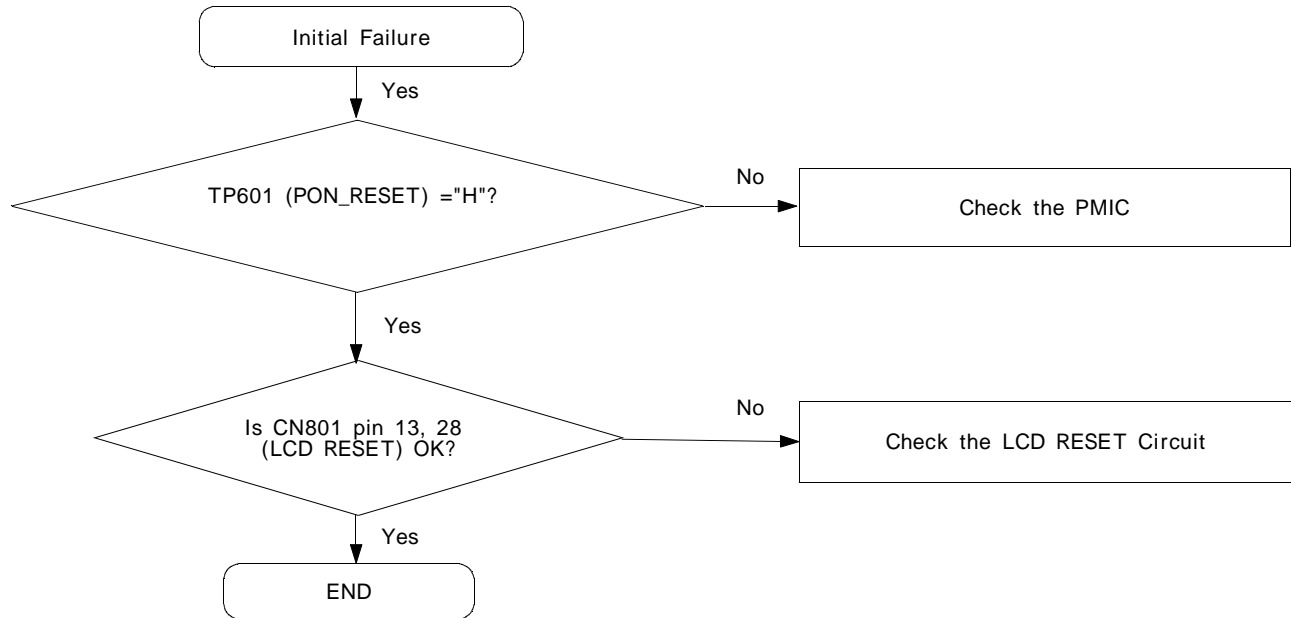

### 3. Sim Part

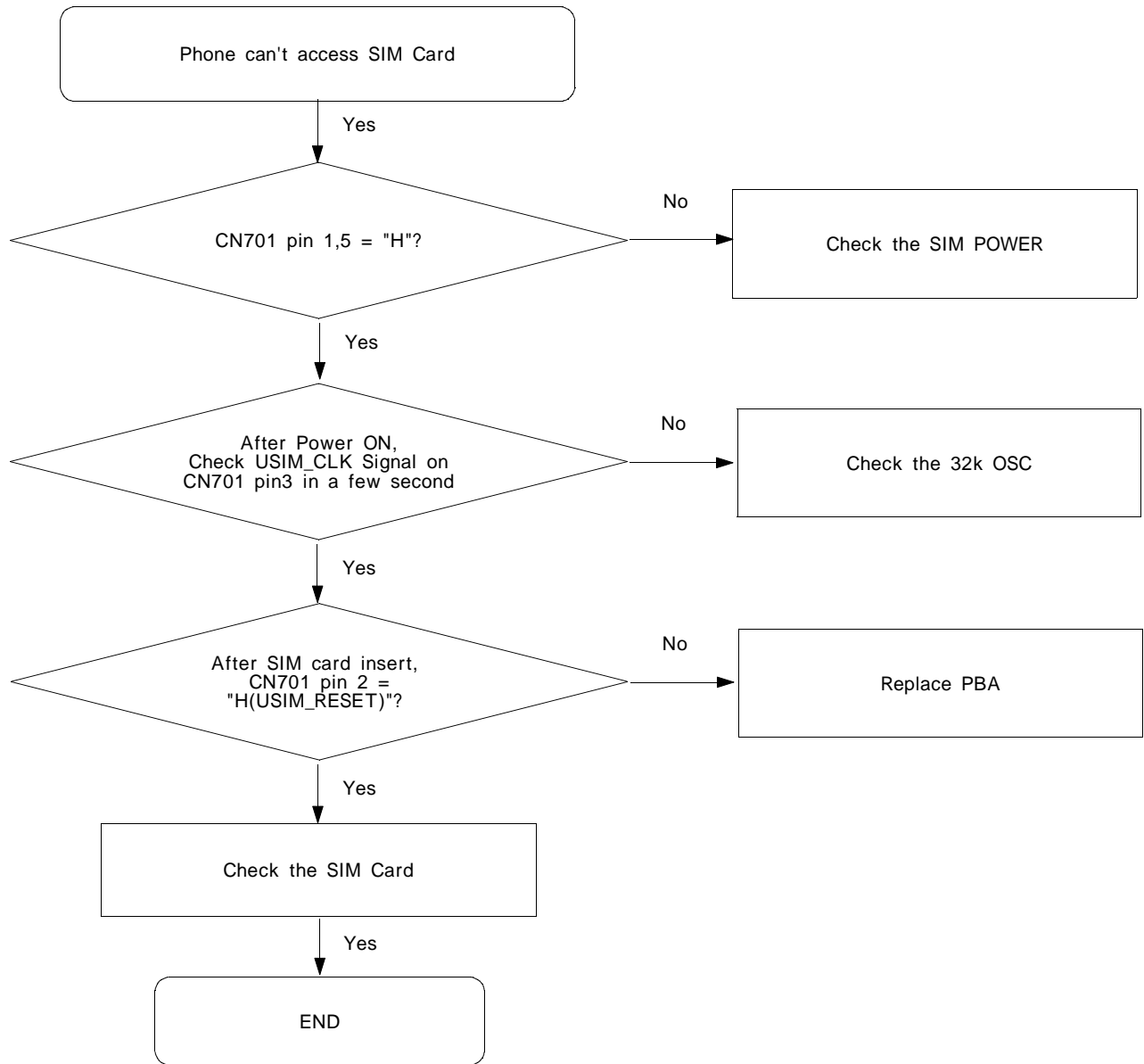

SIM

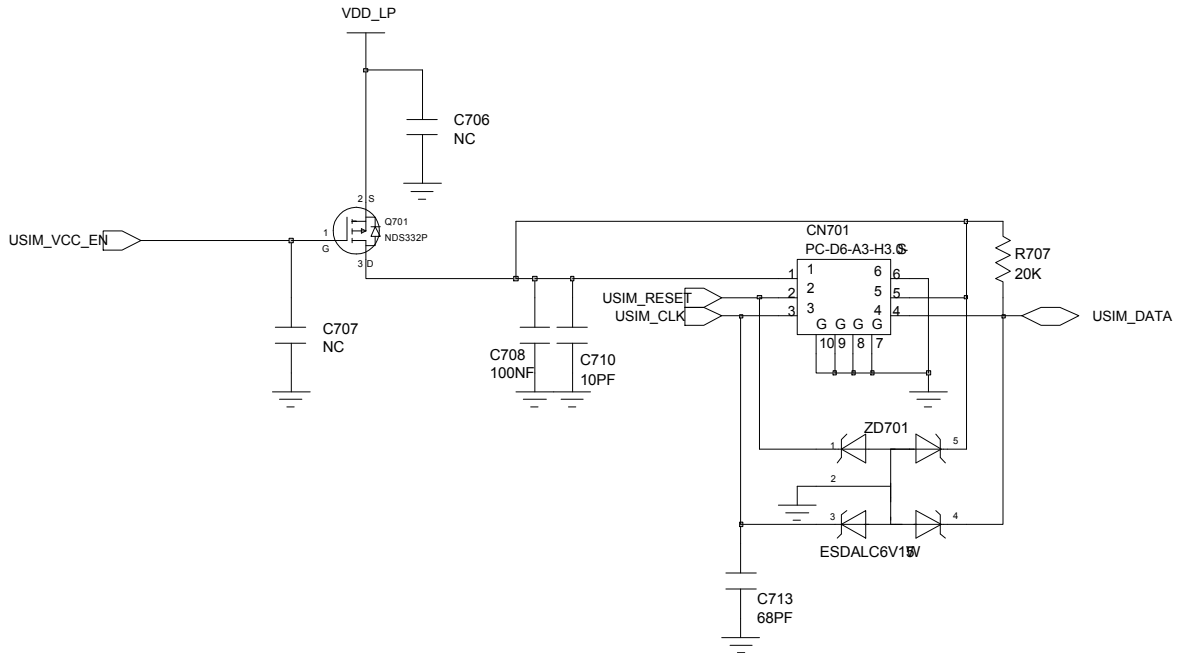

### 4. Microphone Part

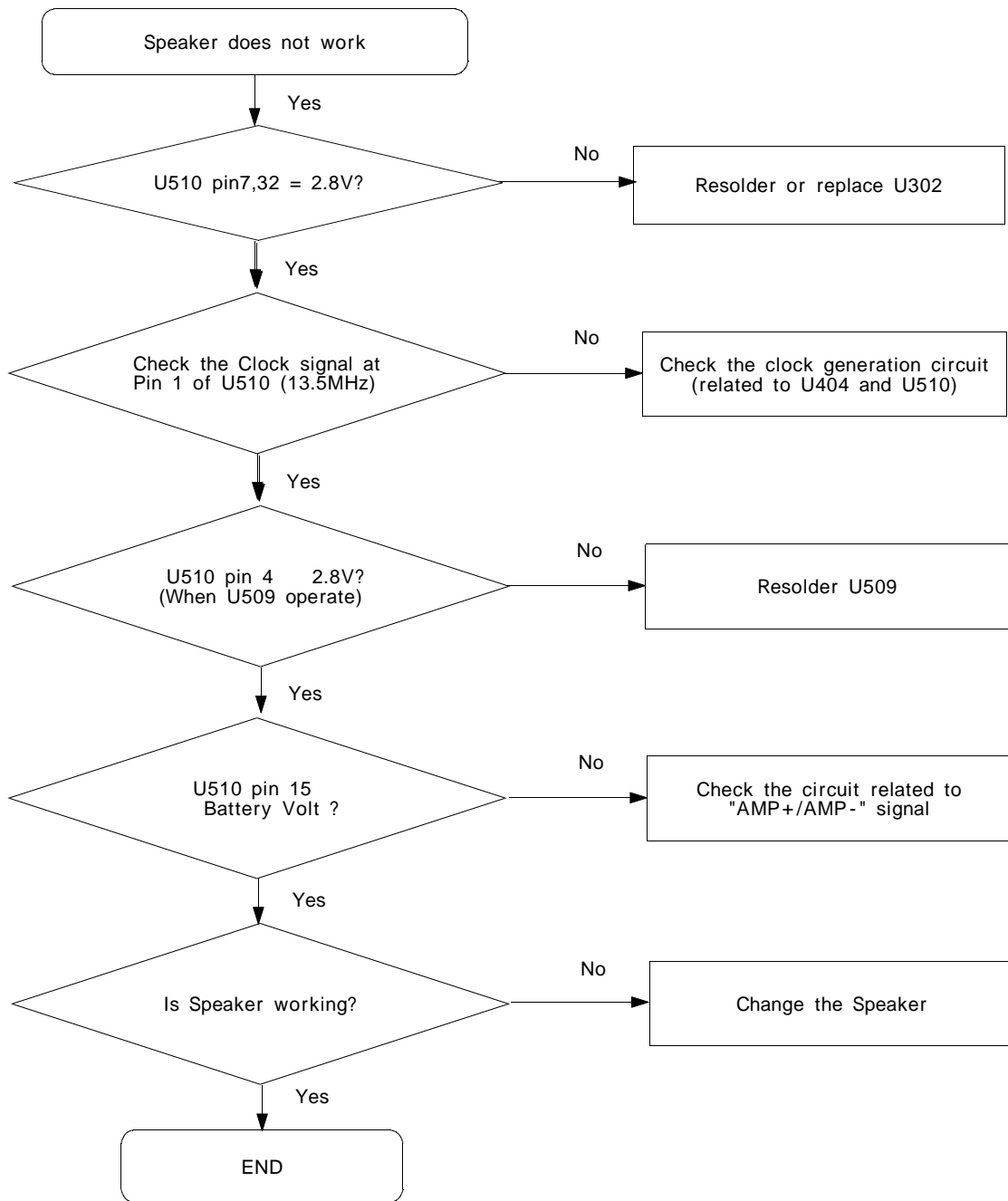



Microphone

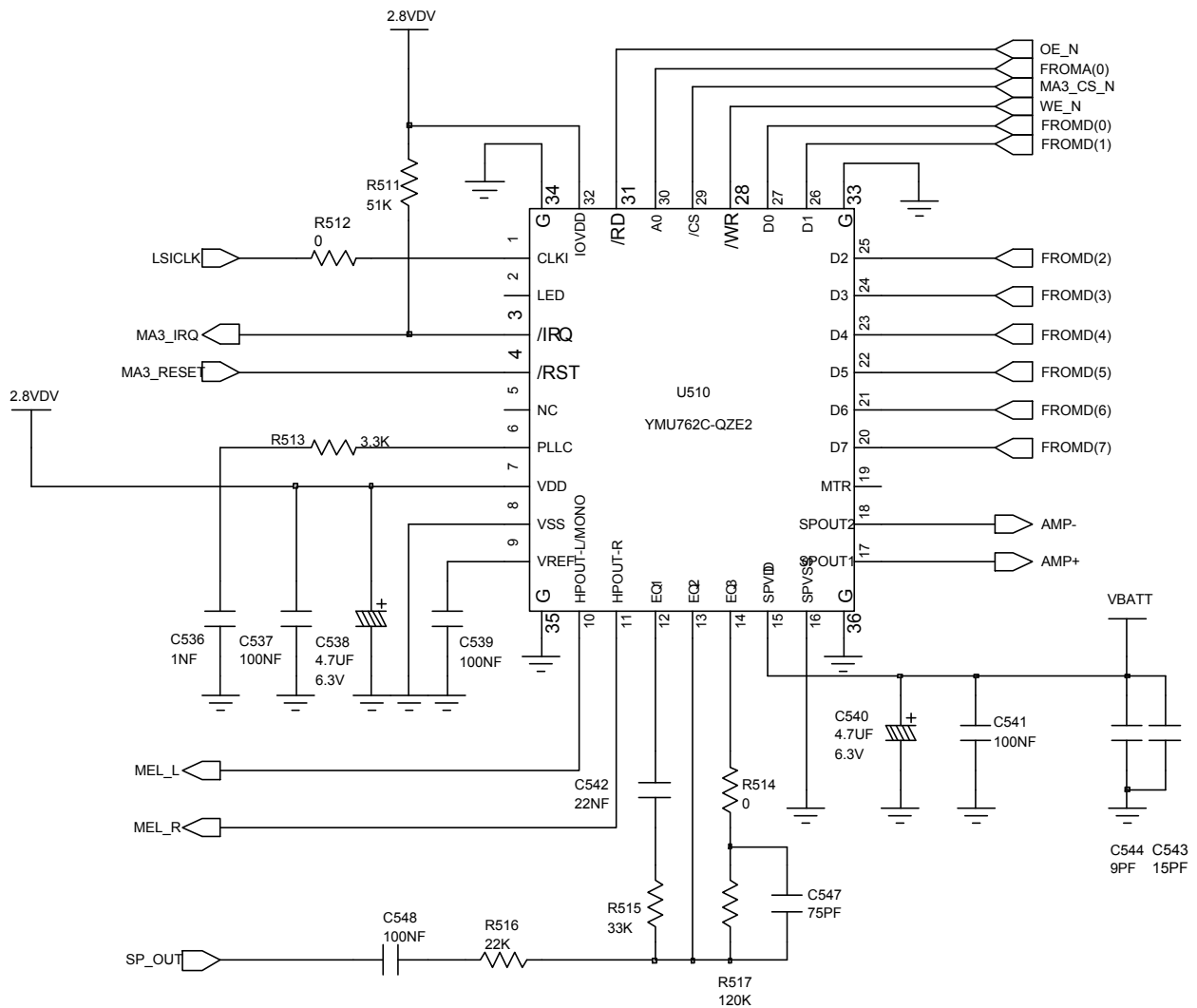

### 5. Speaker Part (Melody)

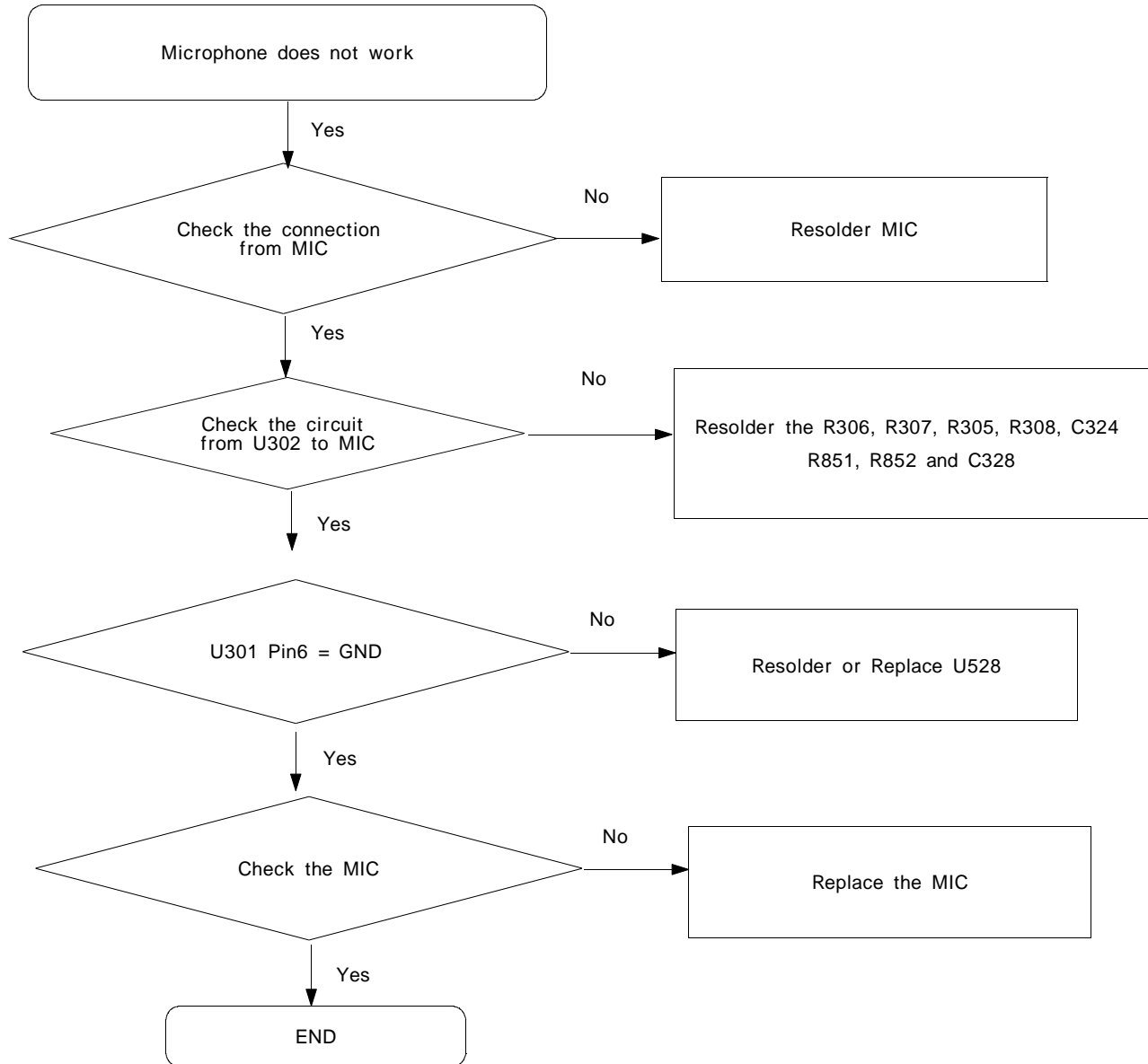

Speaker

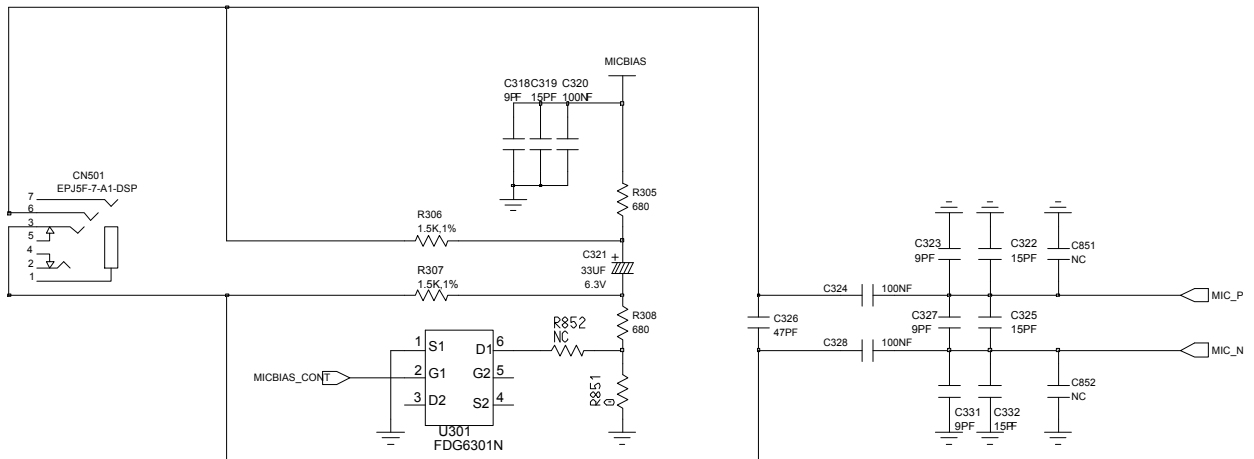

## 6. Key Data Input

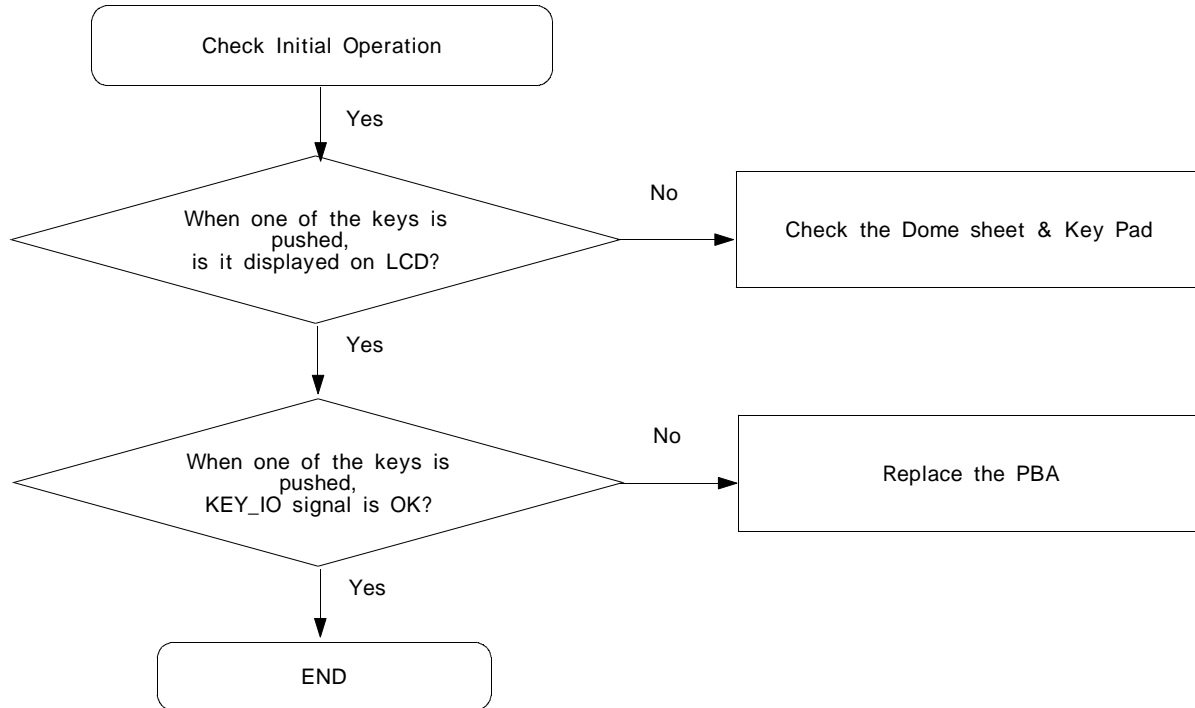

## 7. Receiver Part

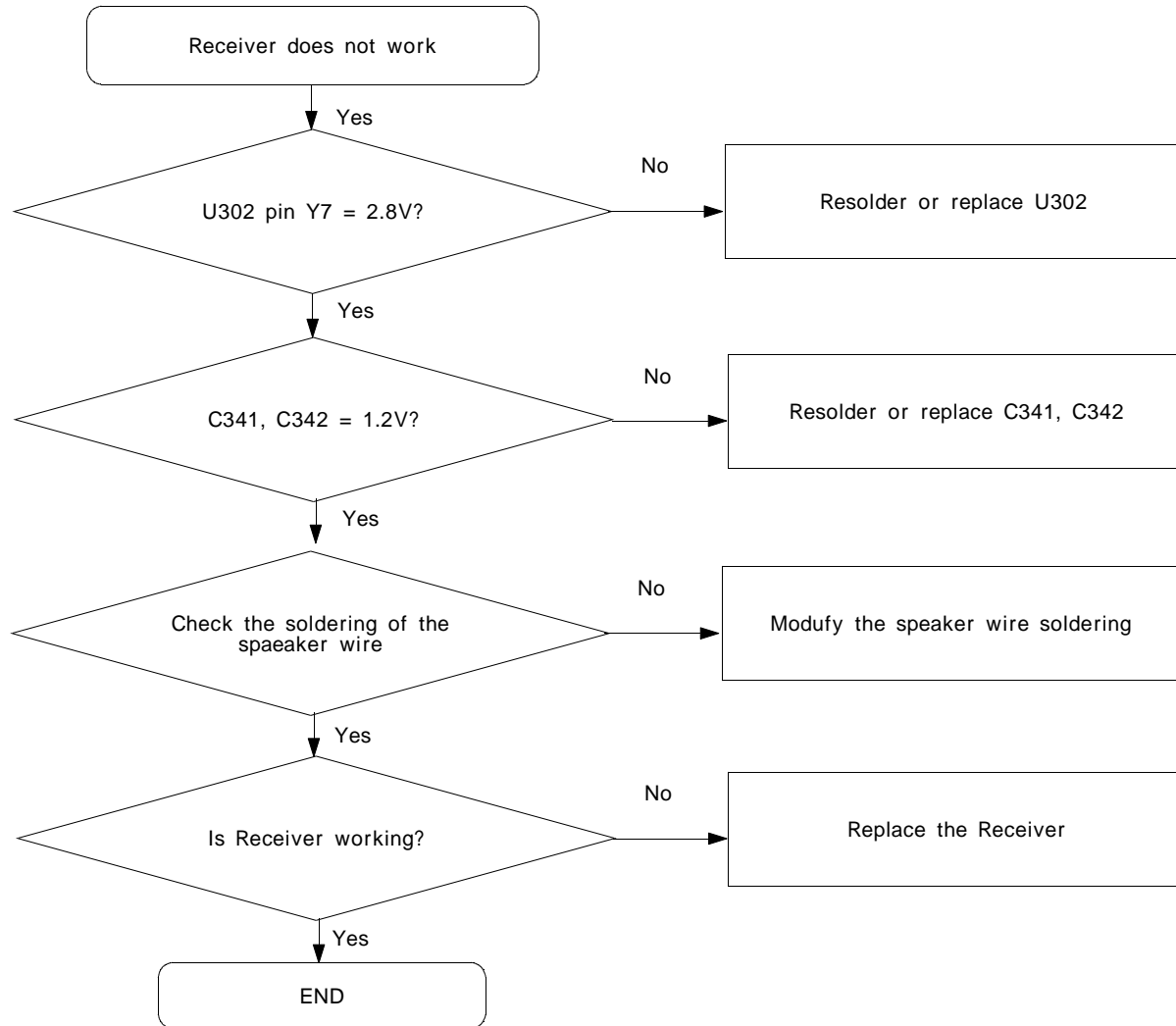

### 8. Back Light (for Color Main LCD)

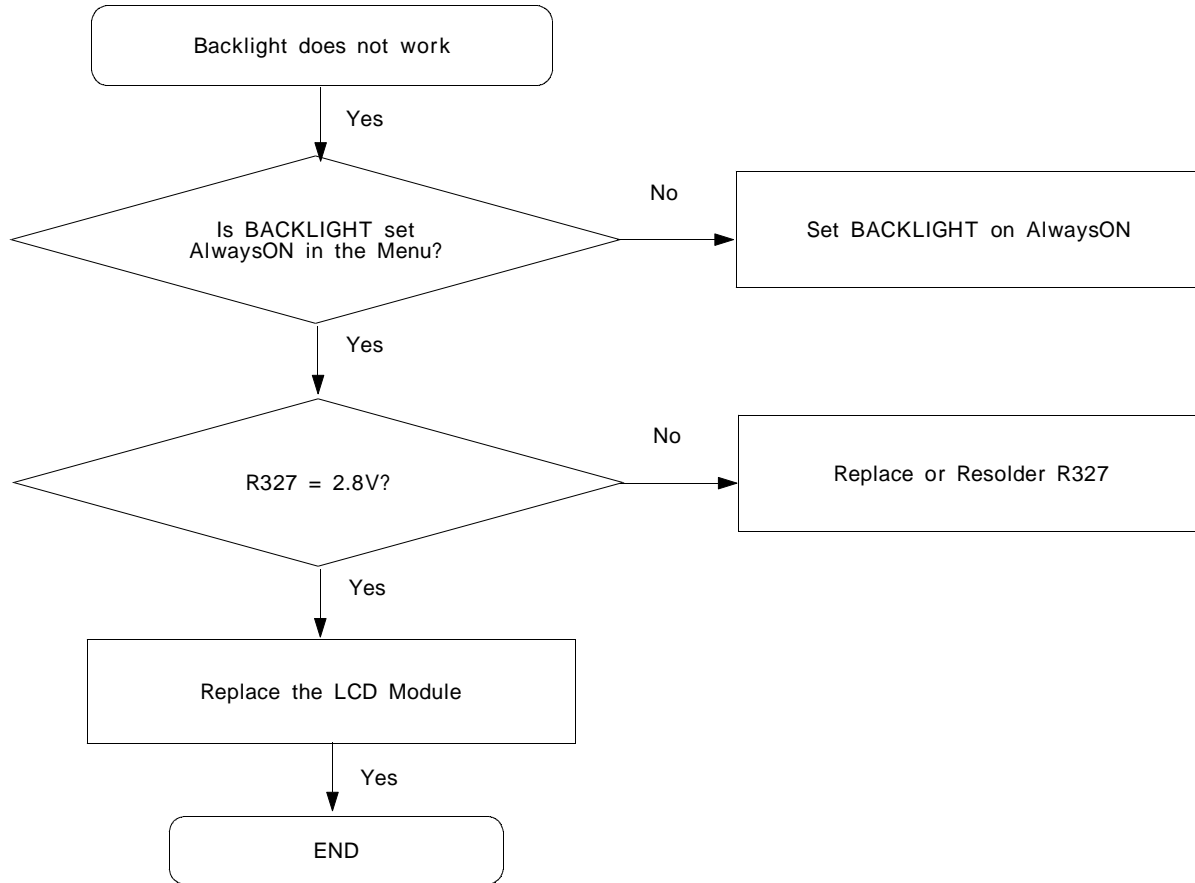

## 9. Key Back Light

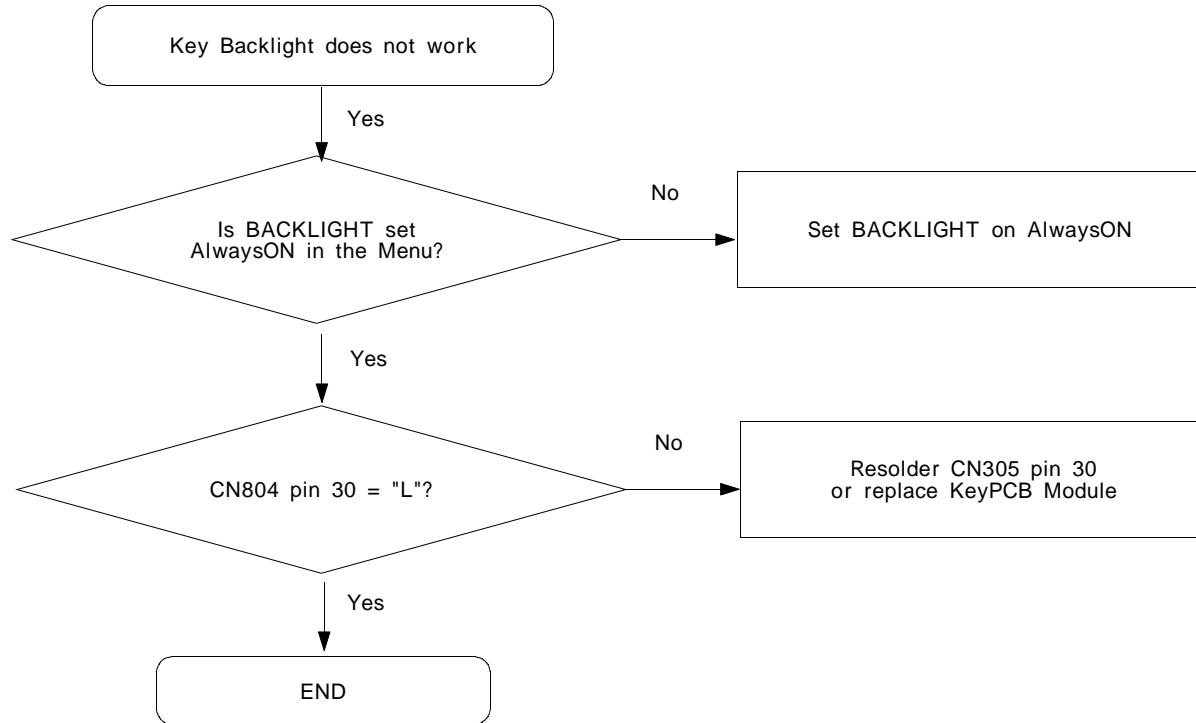

## 10. Camera part

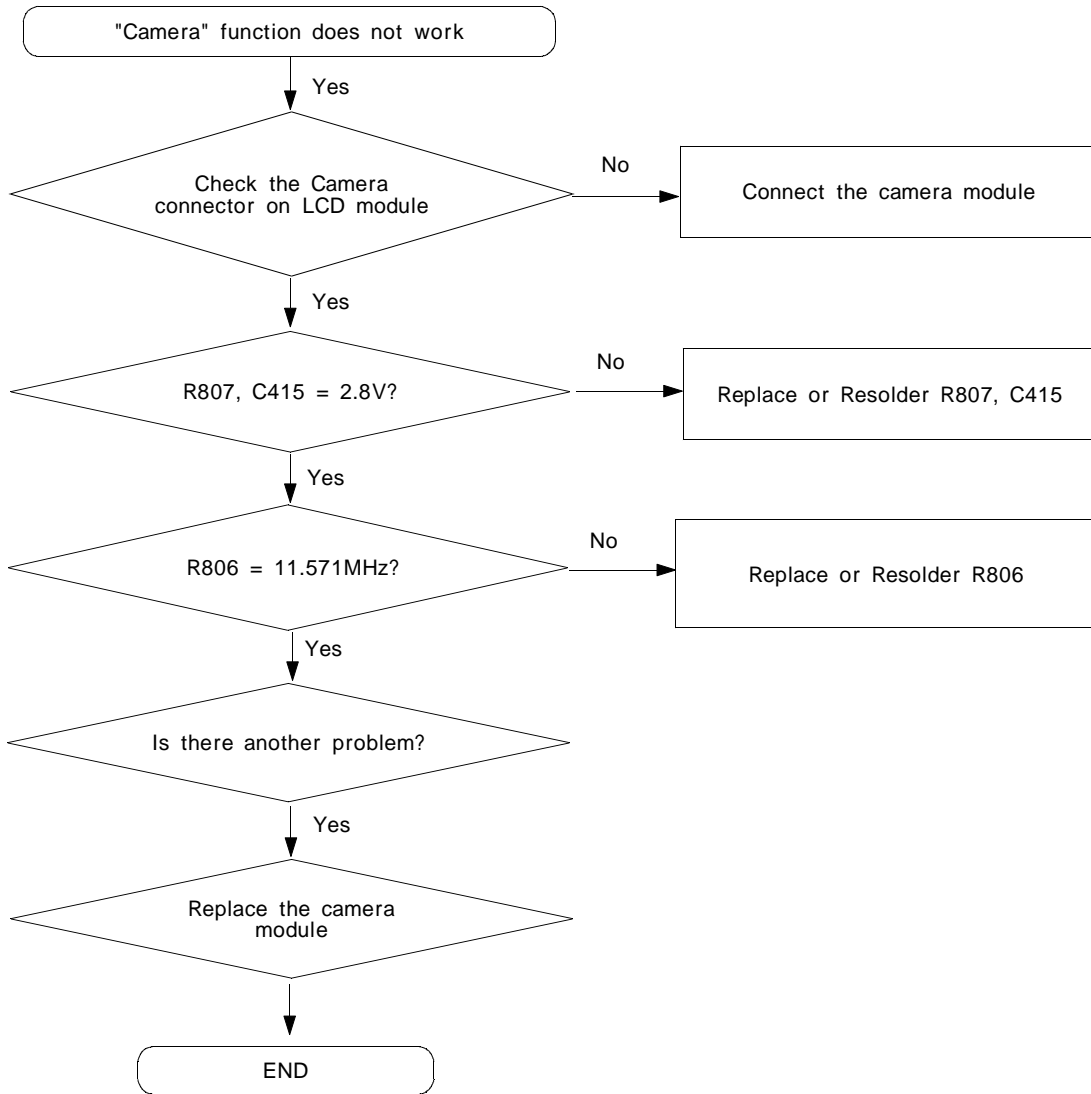



## 11. GSM Receiver

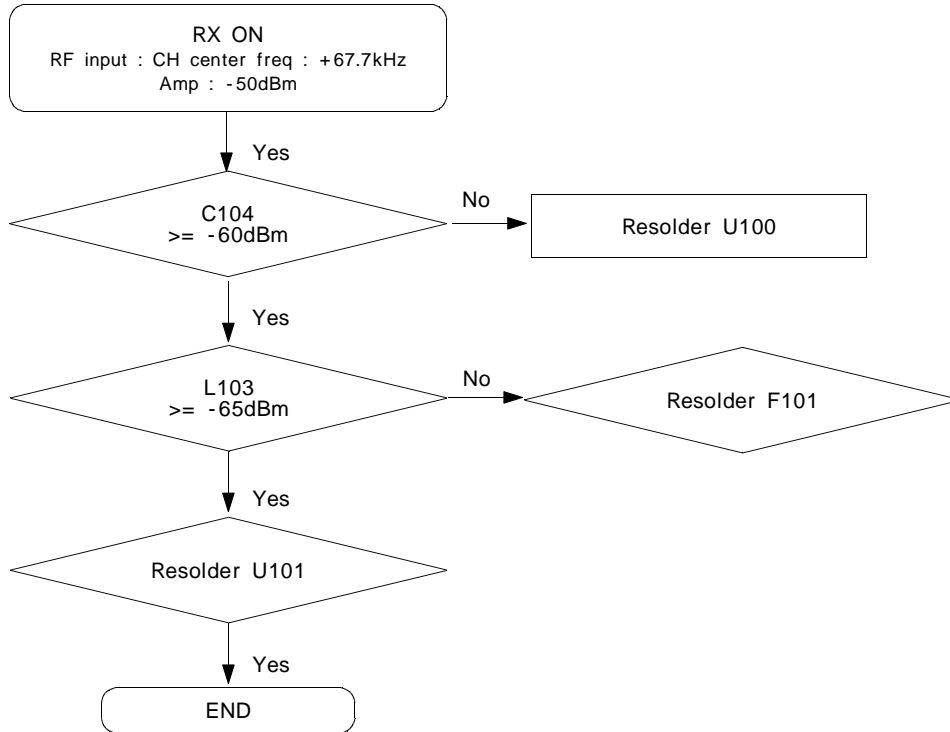

## 12. GSM Transmitter

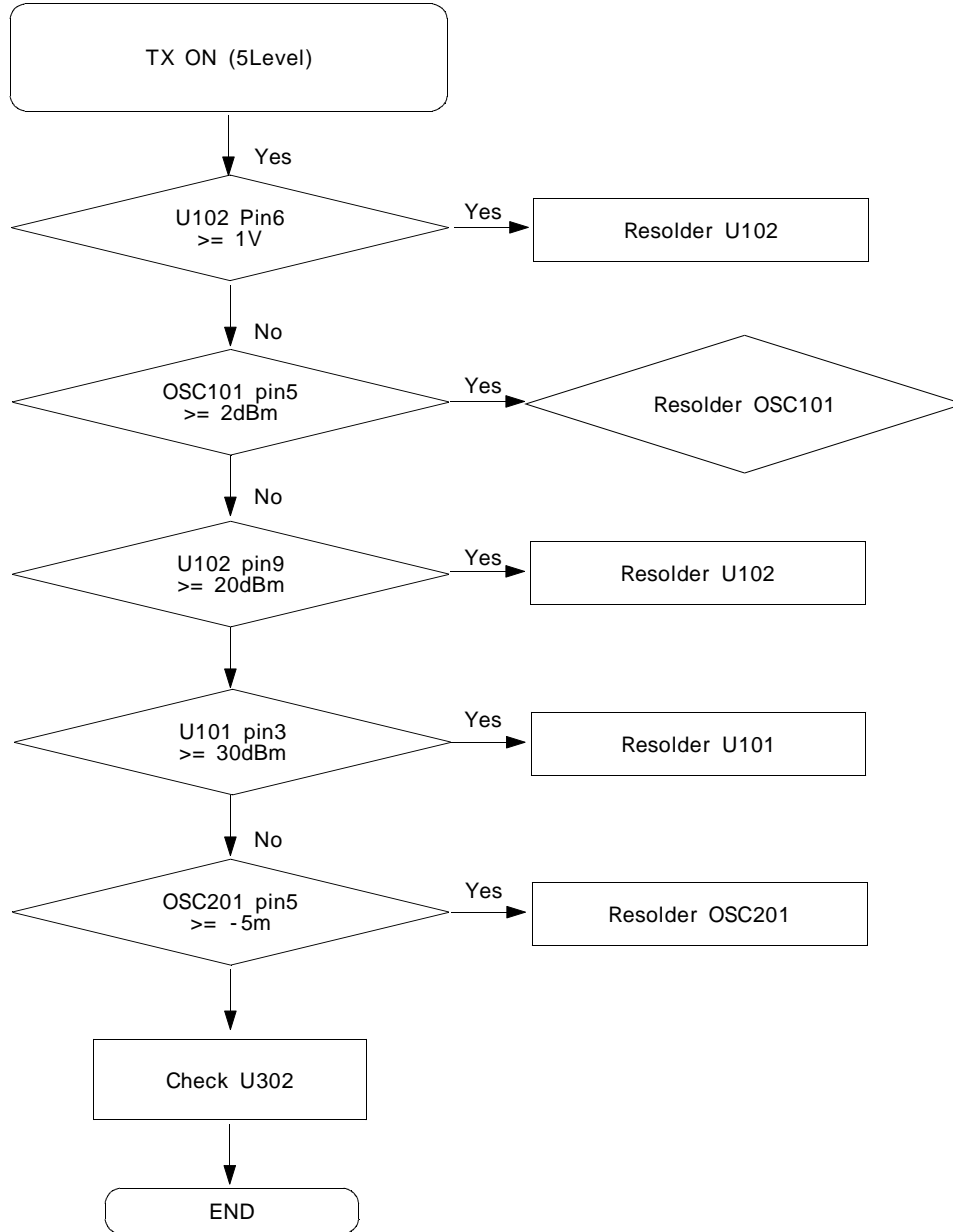

### 13. DCS Receiver

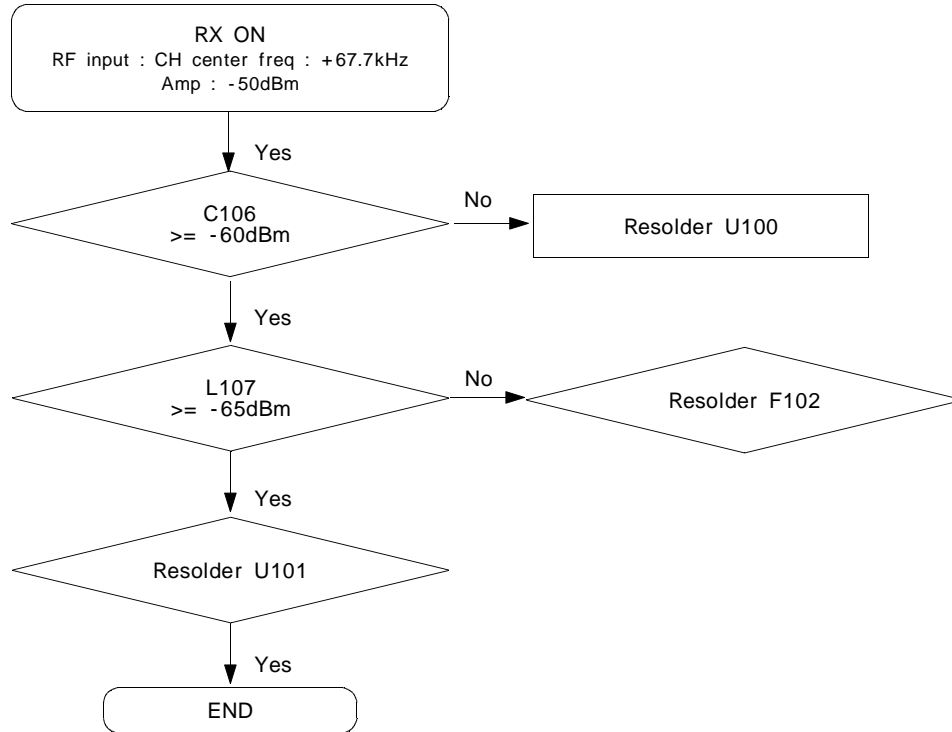

### 14. DCS Transmitter

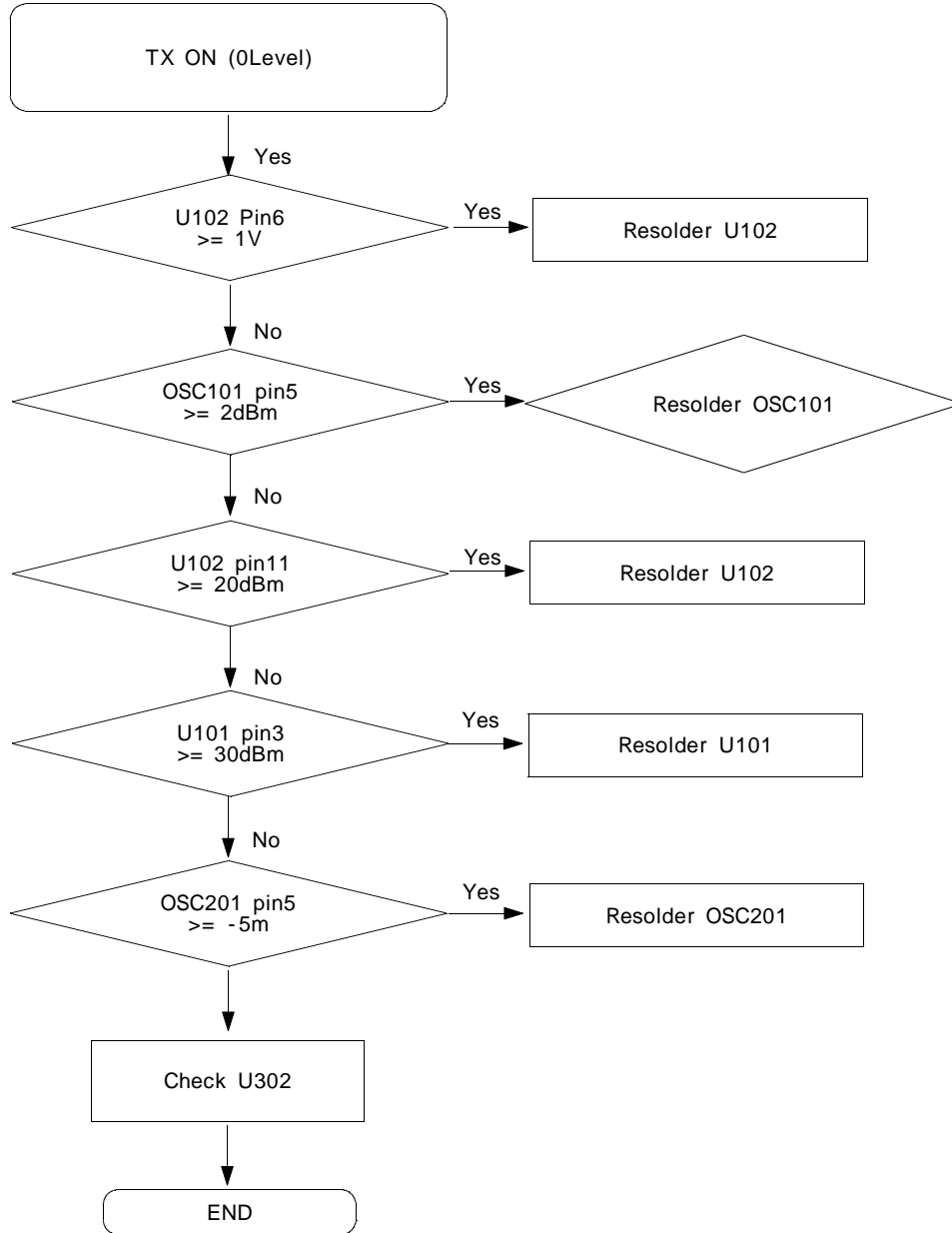

## 15. WCDMA Receiver

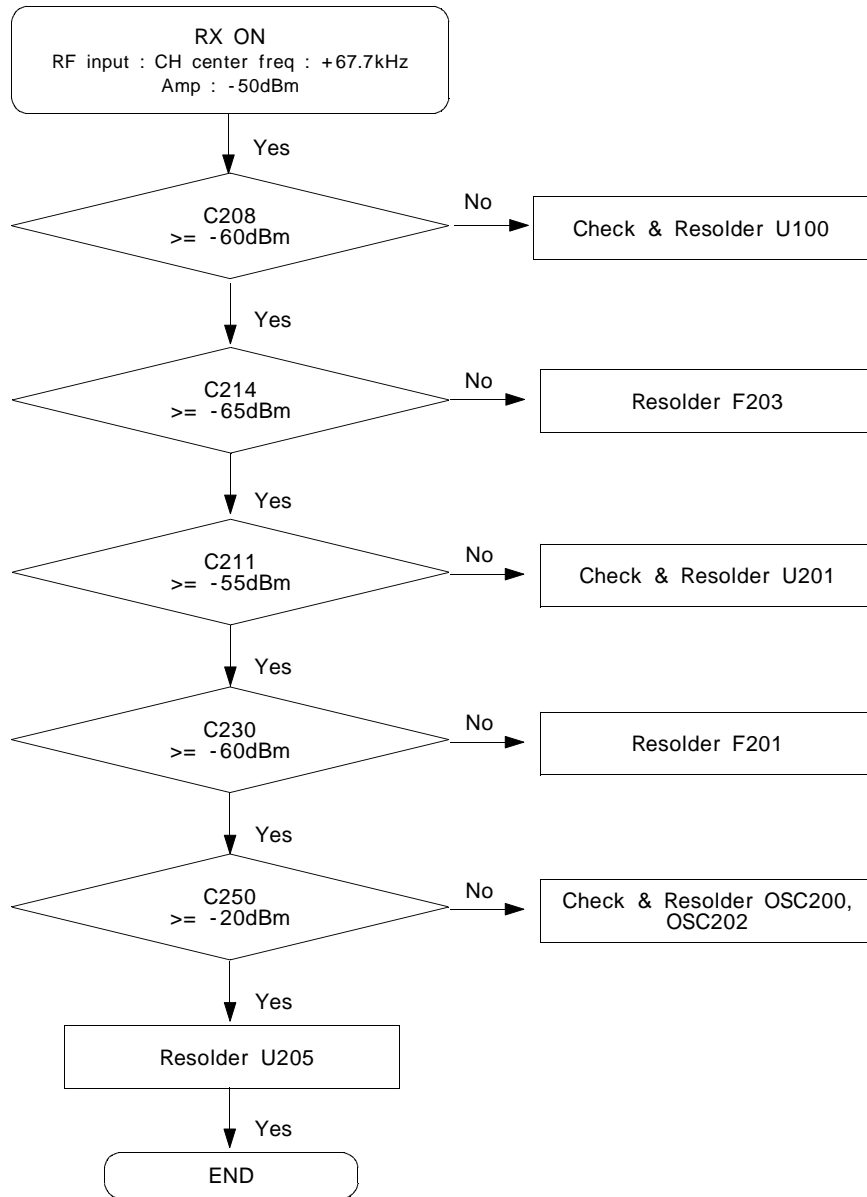

## 16. WCDMA Transmitter

