

**SAMSUNG**

# GSM TELEPHONE

## SGH-X630

# ***SERVICE*** *Manual*

### GSM TELEPHONE

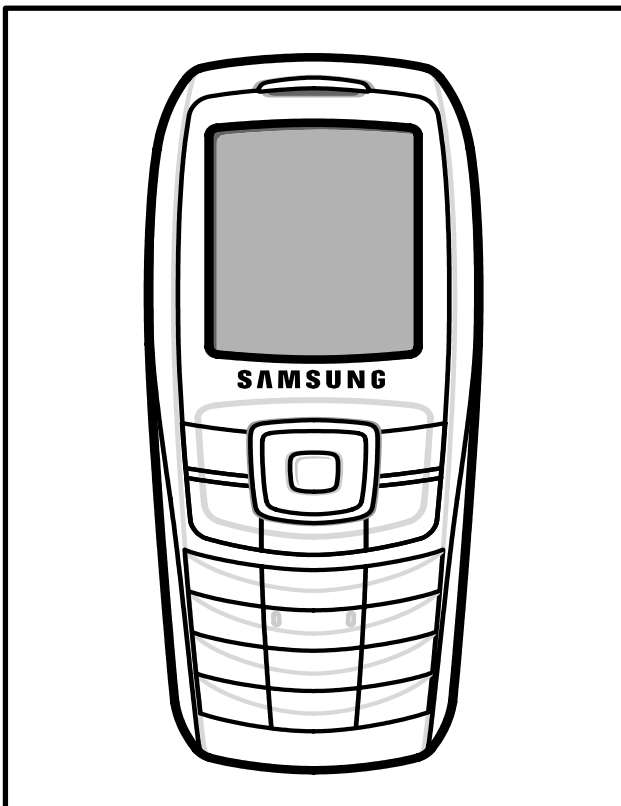

### CONTENTS

1. Safety Precautions
2. Specification
3. Product Function
4. Array course control
5. Exploded View and Parts List
6. Disassembly and Assembly instructions
7. MAIN Electrical Parts List
8. Block Diagrams
9. PCB Diagrams
10. Flow Chart of Troubleshooting
11. Reference data

# Contents

## 1. Safety Precautions

- 1-1. Repair Precaution .....1-1
- 1-2. ESD(Electrostatically Sensitive Devices) Precaution .....1-2

## 2. Specification

- 2-1. GSM General Specification .....2-1
- 2-2. GSM Tx Power Class .....2-2
- 2-3. EDGE TX Power Level .....2-3

## 3. Product Function

- 3-1. Main Function .....3-1

## 4. Array course control

Software Downloading

- 4-1. Downloading Binary Files .....4-2
- 4-2. Pre-requisite for Downloading .....4-2
- 4-3. S/W Downloader Program .....4-3

## 5. Exploded View and Parts List

- 5-1. Cellular phone Exploded View .....5-1
- 5-2. Cellular phone Part list .....5-2

## 6. Disassembly and Assembly instructions

- 6-1. Disassembly .....6-1
- 6-2. Assembly .....6-3

## 7. MAIN Electrical Parts List

## 8. Block Diagrams

## 9. PCB Diagrams

---

# Contents

## 10. Flow Chart of Troubleshooting

### 10-1. Baseband

10-1-1. Power ON .....	10-1
10-1-2. Initial .....	10-4
10-1-3. Sim Part .....	10-7
10-1-4. LCD Display part .....	10-9
10-1-5. Microphone Part .....	10-12
10-1-6. Speaker Part .....	10-15
10-1-7. Receiver Part .....	10-19
10-1-8. Camera Part .....	10-21
10-1-9. Mp3 Part .....	10-23
10-1-10. FM Radio Part .....	10-26

### 10-2. RF

10-2-1. EGSM RX .....	10-28
10-2-2. DCS RX .....	10-29
10-2-3. PCS RX .....	10-30
10-2-4. EGSM TX .....	10-31
10-2-5. DCS & PCS TX .....	10-32

## 11. Reference data

---

---

# 1. Safety Precautions

---

## 1-1. Repair Precaution

- Repair in Shield Box, during detailed tuning.  
Take specially care of tuning or test,  
because specipicty of cellular phone is sensitive for surrounding interference(RF noise).
- Be careful to use a kind of magnetic object or tool,  
because performance of parts is damaged by the influence of manetic force.
- Surely use a standard screwdriver when you disassemble this product,  
otherwise screw will be worn away.
- Use a thicken twisted wire when you measure level.  
A thicken twisted wire has low resistance, therefore error of measurement is few.
- Repair after separate Test Pack and Set because for short danger (for example an  
overcurrent and furious flames of parts etc) when you repair board in condition of  
connecting Test Pack and tuning on.
- Take specially care of soldering, because Land of PCB is small and weak in heat.
- Surely tune on/off while using AC power plug, because a repair of battery charger is  
dangerous when tuning ON/OFF PBA and Connector after disassembling charger.
- Don't use as you pleases after change other material than replacement registered on SEC  
System. Otherwise engineer in charge isn't charged with problem that you don't keep this  
rules.

## **1-2. ESD(Electrostatically Sensitive Devices) Precaution**

Several semiconductor may be damaged easily by static electricity. Such parts are called by ESD (Electrostatically Sensitive Devices), for example IC,BGA chip etc. Read Precaution below. You can prevent from ESD damage by static electricity.

- Remove static electricity remained your body before you touch semiconductor or parts with semiconductor. There are ways that you touch an earthed place or wear static electricity prevention string on wrist.
- Use earthed soldering steel when you connect or disconnect ESD.
- Use soldering removing tool to break static electricity. , otherwise ESD will be damaged by static electricity.
- Don't unpack until you set up ESD on product. Because most of ESD are packed by box and aluminum plate to have conductive power,they are prevented from static electricity.
- You must maintain electric contact between ESD and place due to be set up until ESD is connected completely to the proper place or a circuit board.

## 2. Specification

### 2-1. GSM General Specification

		<b>GSM 900</b>	<b>DCS1800</b>	<b>PCS1900</b>
Freq. Band[MHz] Uplink/Downlink		880~915 925~960	1710~1785 1805~1880	1850~1910 1930~1990
ARFCN range		0~124 & 975~1023	512~885	512~810
Tx/Rx spacing		45 MHz	95 MHz	80 MHz
Mod. Bit rate/ Bit Period	GPRS	270.833 Kbps 3.692 us	270.833 Kbps 3.692 us	270.833 Kbps 3.692 us
	EDGE	812.5 Kbps 3.692 us	812.5 Kbps 3.692 us	812.5 Kbps 3.692 us
Time Slot Period/Frame Period		576.9 us 4.615 ms	576.9 us 4.615 ms	576.9 us 4.615 ms
Modulation	GPRS	0.3 GMSK	0.3 GMSK	0.3 GMSK
	EDGE	8 PSK	8 PSK	8 PSK
MS Power	GPRS	33 dBm~5 dBm	30 dBm~0 dBm	30 dBm~0 dBm
	EDGE	27~5 dBm	26~0 dBm	26~0 dBm
Power Level	GPRS	5 pcl~19 pcl	0 pcl~15 pcl	0 pcl~15 pcl
	EDGE	8~19(class E2)	2~15(class E2)	2~15(class E2)
Sensitivity		-102 dBm	-100 dBm	-102 dBm
TDMA Mux		8	8	8
Cell Radius		35 Km	2 Km	2 Km

## 2-2. GSM Tx Power Class

<b>TX Power control level</b>	<b>GSM900</b>	<b>TX Power control level</b>	<b>DCS1800</b>	<b>TX Power control level</b>	<b>PCS1900</b>
5	33±2 dBm	0	30±2 dBm	0	30±2 dBm
6	31±3 dBm	1	28±3 dBm	1	28±3 dBm
7	29±3 dBm	2	26±3 dBm	2	26±3 dBm
8	27±3 dBm	3	24±3 dBm	3	24±3 dBm
9	25±3 dBm	4	22±3 dBm	4	22±3 dBm
10	23±3 dBm	5	20±3 dBm	5	20±3 dBm
11	21±3 dBm	6	18±3 dBm	6	18±3 dBm
12	19±3 dBm	7	16±3 dBm	7	16±3 dBm
13	17±3 dBm	8	14±3 dBm	8	14±3 dBm
14	15±3 dBm	9	12±4 dBm	9	12±4 dBm
15	13±3 dBm	10	10±4 dBm	10	10±4 dBm
16	11±5 dBm	11	8±4 dBm	11	8±4 dBm
17	9±5 dBm	12	6±4 dBm	12	6±4 dBm
18	7±5 dBm	13	4±4 dBm	13	4±4 dBm
19	5±5 dBm	14	2±5 dBm	14	2±5 dBm
		15	0±5 dBm	15	0±5 dBm

## 2-3. EDGE TX Power Level

<b>TX Power control level</b>	<b>GSM900</b>	<b>TX Power control level</b>	<b>DCS1800</b>	<b>TX Power control level</b>	<b>PCS1900</b>
8	27±3 dBm	2	26±3 dBm	2	26±3 dBm
9	25±3 dBm	3	24±3 dBm	3	24±3 dBm
10	23±3 dBm	4	22±3 dBm	4	22±3 dBm
11	21±3 dBm	5	20±3 dBm	5	20±3 dBm
12	19±3 dBm	6	18±3 dBm	6	18±3 dBm
13	17±3 dBm	7	16±3 dBm	7	16±3 dBm
14	15±3 dBm	8	14±3 dBm	8	14±3 dBm
15	13±3 dBm	9	12±4 dBm	9	12±4 dBm
16	11±5 dBm	10	10±4 dBm	10	10±4 dBm
17	9±5 dBm	11	8±4 dBm	11	8±4 dBm
18	7±5 dBm	12	6±4 dBm	12	6±4 dBm
19	5±5 dBm	13	4±4 dBm	13	4±4 dBm
		14	2±5 dBm	14	2±5 dBm
		15	0±5 dBm	15	0±5 dBm



---

## **3. Product Function**

---

### **3-1. Main Function**

- Camera and camcorder
- Music player
- Bluetooth
- Web browser
- Get personal with photo caller ID
- Name card
- Multimedia Message Service (MMS)
- Java
- Calendar
- Voice recorder
- Alarm

## 4. Array course control

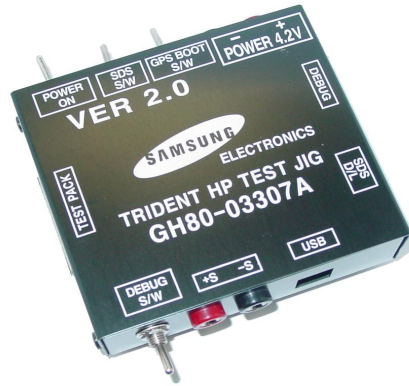

**Test Jig (GH80-03307A)**



**Test Cable (GH39-00127A)**



**RF Test Cable (GH39-00283A)**

## **Software Downloading**

### **4-1. Downloading Binary Files**

- Three binary files for downloading X630.
  - X630XXYY.s3 : Main source code binary.

### **4-2. Pre-requisite for Downloading**

- Downloader Program([OptiFlash.exe](#))
- X630 Mobile Phone
- Data Cable
- Binary files

### 4-3. S/W Downloader Program

1. Load the binary download program by executing the **"OptiFlash.exe"**

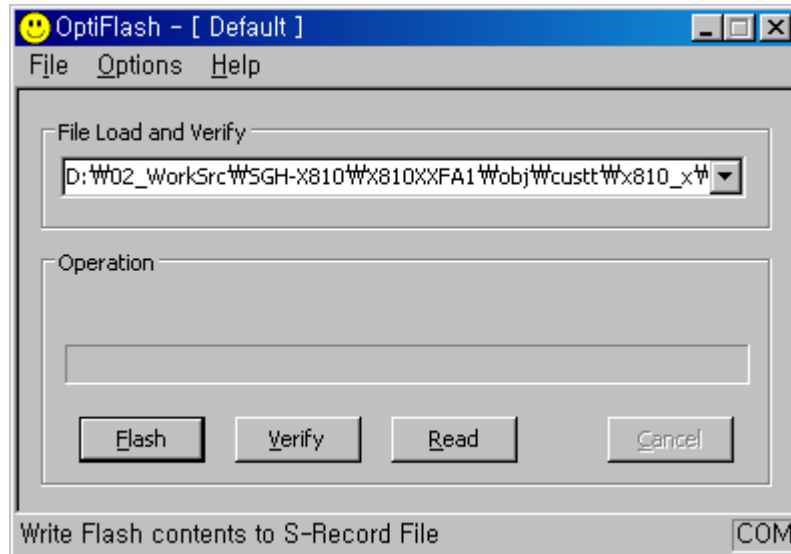

2. Select the **"Options" -> "Settings" -> "Generic" -> "Specify hardware platform"**.

Choose hardware platform for the downloader file setting.

Set the everything else as the default values which are shown below

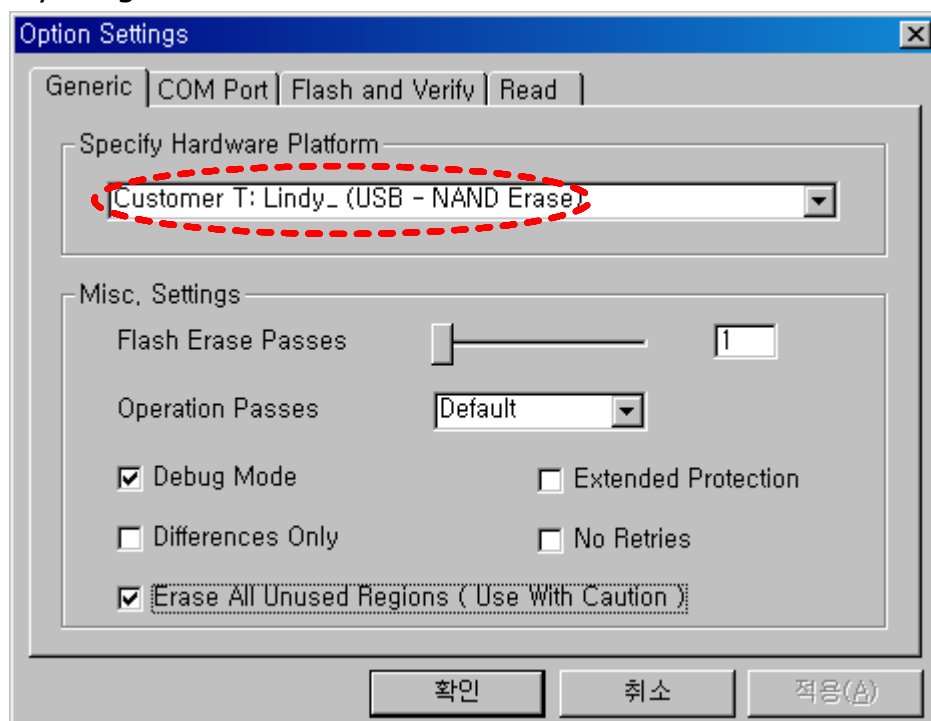

3. Select the **COM port** when the download cable is connected

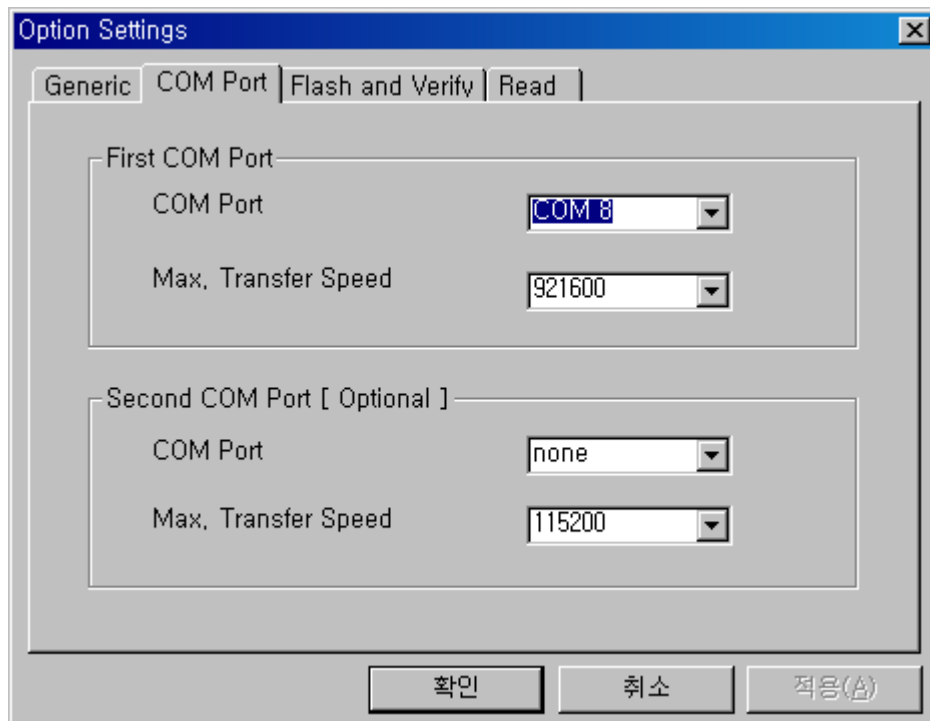

Up to twelve ports are supported. Additionally you can select the maximum transfer speed OptiFlash will use to communicate with the phone. However, OptiFlash will use a slower speed if either the PC's or the phone's serial hardware is incapable of handling the selected speed

4. Select the "**Flash&Verify**" -> "**Browse**"

Set the directory path and choose the latest s/w binary, for example "X630XXYY.s3", for the downloader binary setting.

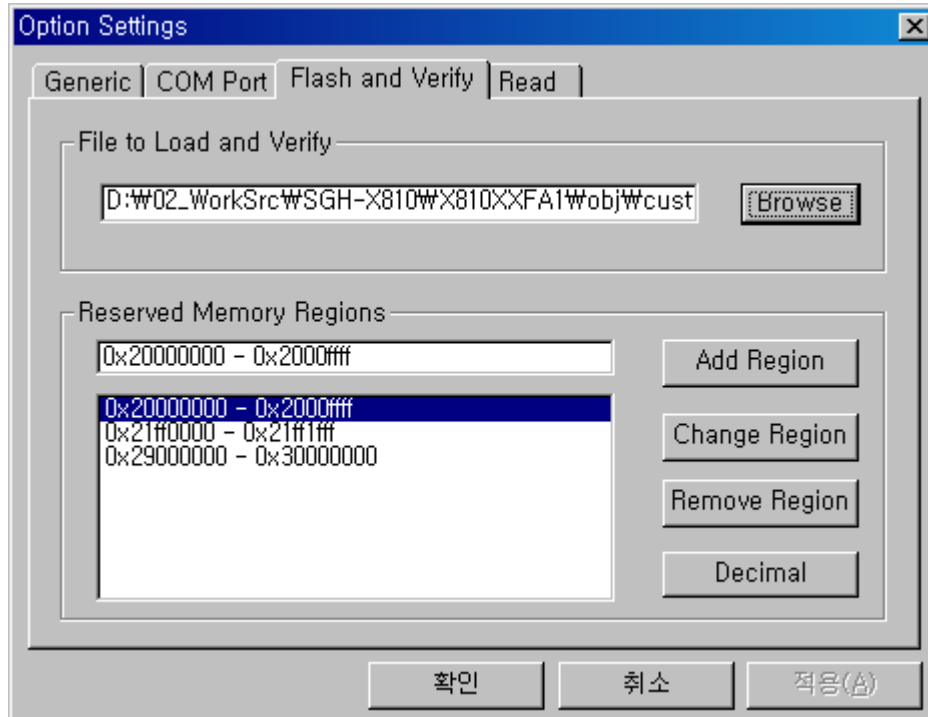

**Make sure that not to change the reserved memory regions.**

**In case of X800 the reserved regions are :**

**-0x20000000 - 0x2000ffff**

**-0x21ff0000 - 0x21ff1fff**

**-0x29000000 - 0x30000000**

5. Click "OK" button then press "Flash".  
(Before pressing 'Flash' button, push the button '\*' and 'END' at the same time. Then press 'Flash'.)

Downloader will upload the binary file as below for the downloading. 🎵

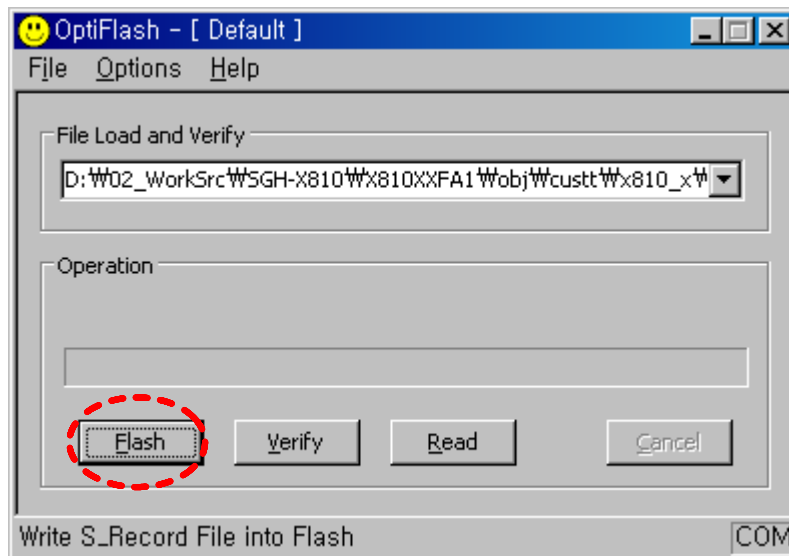

6. When downloading is finished successfully, there is a "All is well" message. 🎵
7. After finishing downloading, Certain memory resets should be done to guarantee the normal performance. 🎵
8. Confirm the downloaded version name and etc. : 🎵

**\*#5002\*8376263#** 🎵

Full Reset : 🎵

**\*2767\*3855#**

# 5. Exploded View and Parts List

## 5-1. Cellular phone Exploded View

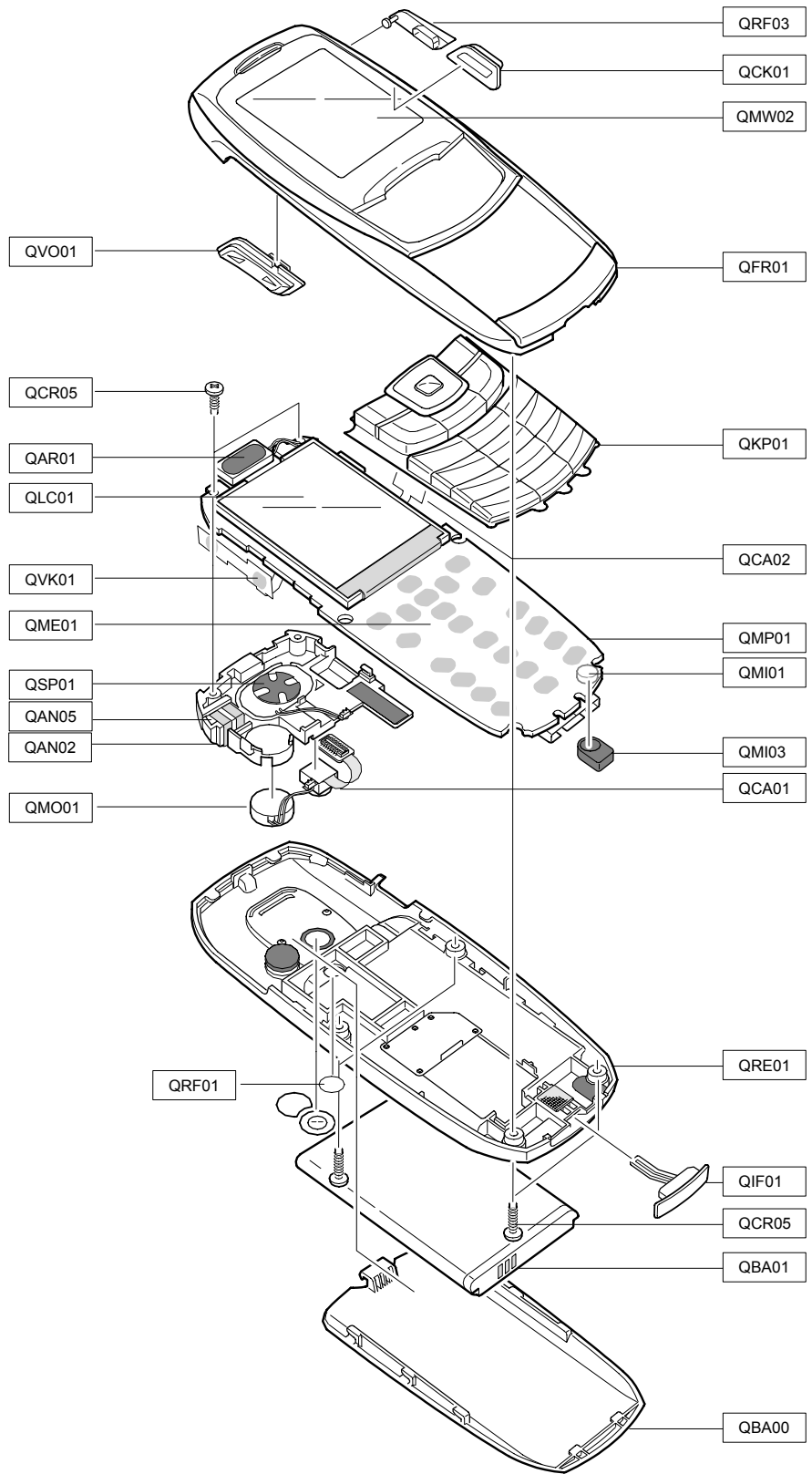







## 5-2. Cellular phone Parts list

Design LOC		Discription	SEC CODE
QAN02		INTENNA-SGHX630	GH42-00815A
QAN05		MEC-INTENNA CONTACT	GH75-08168A
QAR01		AUDIO-RECEIVER	3009-001195
QBA00		PMO-COVER BATTERY	GH72-29602A
QBA01		INNER BATTERY PACK-800MAH,BLK,	GH43-01850A
QCA01		UNIT-CAMERA	GH59-02975A
QCA02		UNIT-CAMERA KEY	GH59-03029A
QCK01		PMO-CAMERA KEY	GH72-29601A
QCR05		SCREW-MACHINE	6001-001478
QCR05		SCREW-MACHINE	6001-001478
QIF01		PMO-COVER IF	GH72-29603A
QKP01		ASSY KEYPAD-(SER/VS)	GH98-01513A
QLC01		LCD-SGHX630 MODULE	GH07-00874A
QME01		UNIT-METAL DOME	GH59-03030A
QMI01		MICROPHONE-ASSY-SGHE340	GH30-00199A
QMI03		RMO-MIC HOLDER	GH73-06602A
QMO01		MOTOR DC-SGHX630	GH31-00235A
QMP01		PBA MAIN-SGHX630	GH92-01656A
QMW02		PMO-COVER WINDOW LCD	GH72-29595A
QRE01		MEC-COVER REAR	GH75-09378A
QRF01		MPR-COVER RF	GH74-21461A
QSP01		SPEAKER	3001-001949
QVK01		UNIT-VOLUME KEY	GH59-03028A
QVO01		PMO-VOLUME KEY	GH72-29600A
QFR01		MEC-COVER FRONT	GH75-09377A
	QRF03	PMO-COVER EAR JACK	GH72-29594A

Discription	SEC CODE
BAG PE	6902-000297
ADAPTOR-SGHN288 TAD	GH44-00184A
UNIT-EARPHONE(BLK)	GH59-02472A
LABEL(P)-WATER SOAK	GH68-02026A
LABEL(P)-WATER SOAK	GH68-02026A
MANUAL-WARRANTY CARD	GH68-02623A
MANUAL-SFC	GH68-04336A
LABEL(P)-BARCODE RUSSIA	GH68-08494A
MANUAL USERS-EU RUSSIAN	GH68-09947A
LABEL(R)-MAIN(SER)	GH68-10706A
CUSHION-CASE TA2 MA2	GH69-03902A
BOX(P)-UNIT MAIN(SER)	GH69-03903A
MPR-CUSHION CAMERA CONN	GH74-21462A
MPR-TAPE LCD WINDOW	GH74-21488A
MPR-TAPE LCD 1	GH74-22951A
MPR-TAPE LCD 2	GH74-22952A
MPR-TAPE HW	GH74-22953A
MPR-VINYL BOHO WINDOW 1	GH74-22954A
MPR-VINYL BOHO WINDOW 2	GH74-22956A
MPR-VINYL BOHO WINDOW 3	GH74-22958A
MPR-TAPE MOTOR WIRE	GH74-24456A
MPR-TAPE LCD FPCB	GH74-24457A
MPR-TAPE LCD TOP	GH74-24458A

## 6. Disassembly and Assembly instructions

### 6-1. Disassembly

<p>1</p> 	<p>2</p> <div style="border: 2px solid red; padding: 5px; background-color: yellow; margin-bottom: 10px;"> <p><b>-USE DISASSEMBLING TOOL(MUST)</b>  <b>-HANDLE WITH CARE NOT TO BREAK THE REAR COVER.</b></p> </div> 
<p>1) LOOSE THE FOUR SCREWS ON THE REAR COVER AND SEPARATE THEM FROM THE REAR COVER.</p> <p><b>* caution</b></p> <p>1) BE CAUTIOUS NOT TO DAMAGE OR SCRATCH THE REAR COVER.</p>	<p>1) USING THE DISASSEMBLING TOOL, OPEN THE SIDE LOCKER BY PUSHING THE SIDE HOOK.</p> <p><b>* caution</b></p> <p>1) BE CAUTIOUS NOT TO DAMAGE OR SCRATCH THE REAR COVER.</p>
<p>3</p> 	<p>4</p> 
<p>1) USING THE DISASSEMBLING TOOL, OPEN THE OPPOSITE SIDE LOCKER BY PUSHING THE HOOK.</p> <p>2) SEPARATE THE REAR COVER FROM THE HANDSET.</p> <p><b>* caution</b></p> <p>1) BE CAUTIOUS NOT TO DAMAGE OR SCRATCH THE REAR COVER.</p>	<p>1) SEPARATE CAMERA-KEY AND VOLUME-KEY.</p> <p><b>* caution</b></p> <p>1) TAKE CARE NOT TO DAMAGE F-PCB AND CONNECTOR.</p>

5

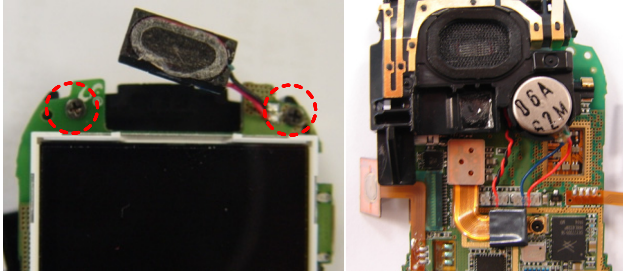

- 1) LOOSE TWO SCREWS AND SEPARATE THEM.
- 2) SEPARATE CAMERA MODULE FROM ANTENNA ASS'Y.
- 2) SEPARATE ANTENNA LOCKERS CAREFULLY.
- ※ **caution**
- 1) BE CAUTIOUS NOT TO BREAK ANTENNA LOCKERS.
- 2) BE CAUTIOUS NOT TO TEAR CAMERA FPCB.

6

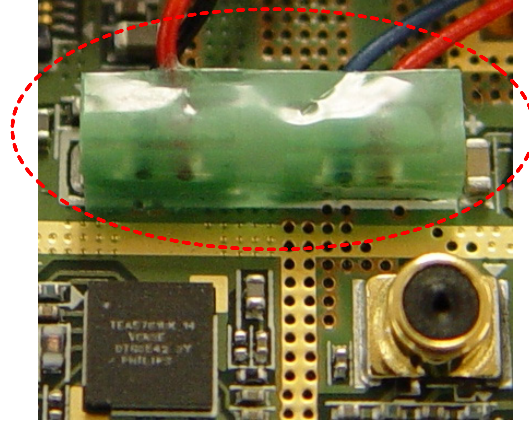

- 1) REMOVE THE TAPE FROM SPEAKER & MOTOR CONNECTOR.
- 2) SEPARATE SPEAKER & MOTOR CONNECTOR.

7

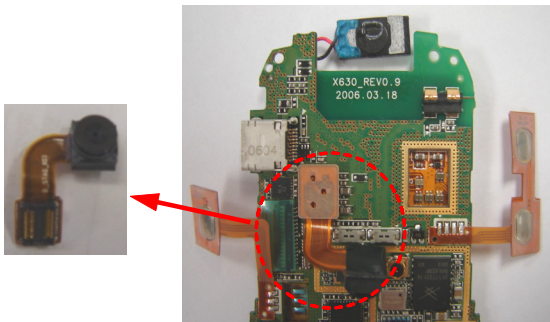

- 1) SEPARATE CAMERA CONNECTOR.
- ※ **caution**
- 1) CONFIRM CAMERA F-PCB TO BE GOOD.

8

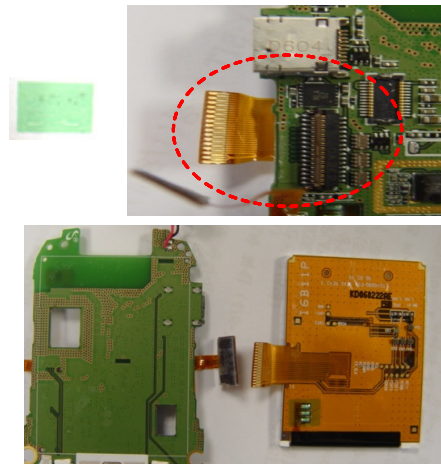

- 1) REMOVE INSULATION TAPE.
- 2) OPEN THE LCD CONNECTOR AND SEPARATE THE LCD F-PCB.
- 3) SEPARATE LCD MODULE.
- ※ **caution**
- 1) SEPARATE CAREFULLY NOT TO DAMAGE THE LCD MODULE.

## 6-2. Assembly

<p>1</p> <p style="text-align: center;"><b>CHECK THE GUIDE RIB.</b></p> 	<p>2</p>  
<p>1) PUT THE KEYPAD ON THE GROOVE OF FRONT.</p> <p><b>* caution</b></p> <p>1) CONFIRM SAFE ARRIVAL OF KEYPAD ON THE GUIDE RIB.</p>	<p>1) CONNECT LCD FPCB TO LCD CONNECTOR.</p> <p>2) ATTACH LCD TO MAIN PBA ACCORDING TO THE GUIDE RIB.</p> <p>3) ATTACH THE INSULATION TAPE.</p> <p><b>* caution</b></p> <p>1) CONFIRM GOOD CONNECTION BETWEEN FPCB AND CONNECTOR.</p>
<p>3</p> 	<p>4</p> 
<p>1) JOIN CAMERA MODULE TO MAIN PBA.</p> <p><b>* caution</b></p> <p>1) CONFIRM GOOD CONNECTION BETWEEN FPCB AND CONNECTOR. 2) CONFIRM THE CONNECTOR NOT TO BE TILTED.</p>	<p>1) JOIN THE ANTENNA AND SCREW DOWN.</p> <p><b>* caution</b></p> <p>1) CONFIRM SAFE ARRIVAL OF ANTENNA.</p>

5

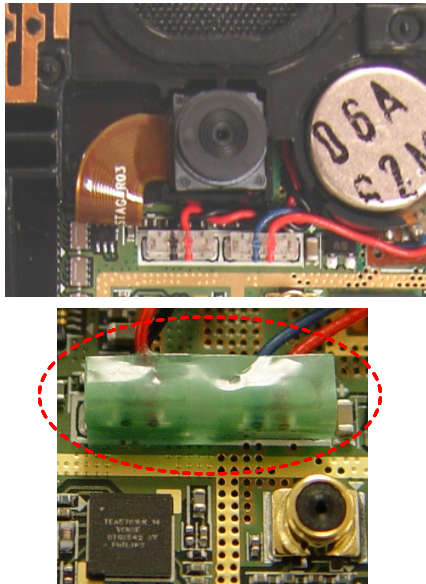

- 1) PUT THE CAMERA ON THE ROOM.
- 2) CONNECT MOTOR AND SPEAKER.
- 3) ATTACH THE INSULATION TAPE ON IT.

**\* caution**

- 1) CONFIRM CAMERA MODULE NOT TO BE TILTED.

6

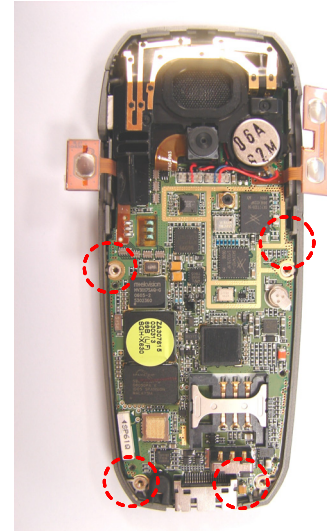

- 1) PUT THE MAIN PBA TO THE FRONT ACCORDING TO THE BOSS AND PBA HOLDER.(SEE THE PICTURE BELOW.)

**\* caution**

- 1) CONFIRM SAFE ARRIVAL OF MAIN PBA.

7

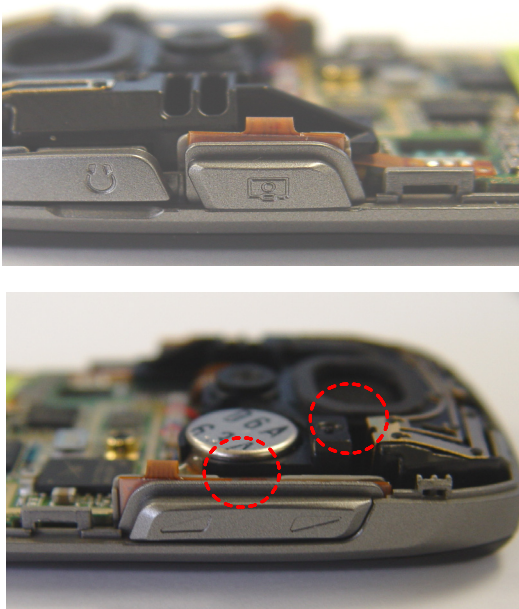

- 1) JOIN THE CAMERA KEY AND VOLUME KEY.

**\* caution**

- 1) CONFIRM THE RIGHT DIRECTION.
- 2) CONFIRM GOOD CLICK SENSITIVITY.

8



- 1) JOIN THE REAR COVER.
- 2) CENTER THE CAMERA.

**\* caution**

- 1) CONFIRM THE CAMERA TO BE CENTERED.

9



1) JOIN THE REAR COVER BY PUSHING IT WITH HANDS.

**\* caution**

1) CONFIRM THAT THERE IS NO GAP BETWEEN FRONT AND REAR.

10

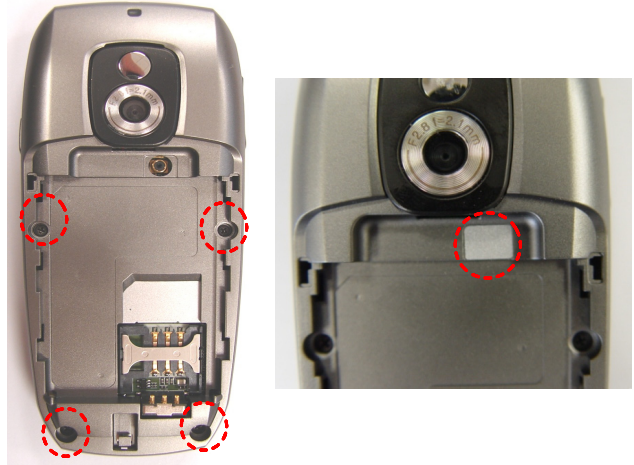

1) SCREW DOWN ON THE 4 POINTS OF REAR COVER.

3) ATTACH THE RF SHEET ON THE RIGHT POSITION.

## 7. MAIN Electrical Parts List

SEC CODE	Design LOC	Discription	STATUS
4202-001072	ANT101	ANTENNA-CHIP	SA
4302-001158	BAT101	BATTERY-LI(2ND)	SA
3711-006084	BTC602	HEADER-BATTERY	SA
2203-006194	C100	C-CER,CHIP	SA
2203-000254	C101	C-CER,CHIP	SA
2203-005061	C102	C-CER,CHIP	SA
2203-005061	C104	C-CER,CHIP	SA
2203-005061	C106	C-CER,CHIP	SA
2203-006183	C107	C-CER,CHIP	SA
2203-000679	C108	C-CER,CHIP	SA
2203-000812	C109	C-CER,CHIP	SA
2203-000812	C110	C-CER,CHIP	SA
2203-006466	C111	C-CER,CHIP	SA
2203-000233	C113	C-CER,CHIP	SA
2203-006562	C115	C-CER,CHIP	SA
2203-006562	C116	C-CER,CHIP	SA
2203-006260	C117	C-CER,CHIP	SA
2203-006562	C118	C-CER,CHIP	SA
2203-006562	C119	C-CER,CHIP	SA
2203-005061	C120	C-CER,CHIP	SA
2203-006562	C121	C-CER,CHIP	SA
2203-000254	C122	C-CER,CHIP	SA
2203-001405	C123	C-CER,CHIP	SA
2203-001405	C124	C-CER,CHIP	SA
2203-005061	C125	C-CER,CHIP	SA
2203-006562	C126	C-CER,CHIP	SA
2203-006190	C200	C-CER,CHIP	SA
2203-000438	C201	C-CER,CHIP	SA
2203-006838	C202	C-CER,CHIP	SA
2203-000254	C203	C-CER,CHIP	SA
2203-006423	C204	C-CER,CHIP	SA
2203-000254	C205	C-CER,CHIP	SA
2203-000254	C206	C-CER,CHIP	SA
2203-005482	C207	C-CER,CHIP	SA
2203-001405	C208	C-CER,CHIP	SA
2203-005061	C209	C-CER,CHIP	SA
2203-006348	C210	C-CER,CHIP	SA
2203-000330	C211	C-CER,CHIP	SA



Main Electrical Parts List

SEC CODE	Design LOC	Discription	STATUS
2203-000330	C212	C-CER,CHIP	SA
2203-005061	C213	C-CER,CHIP	SA
2203-005061	C214	C-CER,CHIP	SA
2203-006562	C300	C-CER,CHIP	SA
2203-000254	C302	C-CER,CHIP	SA
2203-006423	C303	C-CER,CHIP	SA
2203-000254	C304	C-CER,CHIP	SA
2203-006423	C305	C-CER,CHIP	SA
2203-005482	C306	C-CER,CHIP	SA
2203-005482	C307	C-CER,CHIP	SA
2203-005482	C308	C-CER,CHIP	SA
2203-006562	C309	C-CER,CHIP	SA
2203-005482	C310	C-CER,CHIP	SA
2203-005482	C311	C-CER,CHIP	SA
2203-006194	C312	C-CER,CHIP	SA
2203-006423	C313	C-CER,CHIP	SA
2203-000386	C314	C-CER,CHIP	SA
2203-000386	C315	C-CER,CHIP	SA
2203-006562	C400	C-CER,CHIP	SA
2203-000254	C402	C-CER,CHIP	SA
2203-000854	C403	C-CER,CHIP	SA
2203-000254	C404	C-CER,CHIP	SA
2203-001124	C405	C-CER,CHIP	SA
2203-001124	C406	C-CER,CHIP	SA
2203-000233	C409	C-CER,CHIP	SA
2203-006348	C410	C-CER,CHIP	SA
2203-005061	C411	C-CER,CHIP	SA
2203-005061	C413	C-CER,CHIP	SA
2203-005061	C414	C-CER,CHIP	SA
2203-005061	C415	C-CER,CHIP	SA
2203-000628	C418	C-CER,CHIP	SA
2203-005061	C419	C-CER,CHIP	SA
2203-000854	C420	C-CER,CHIP	SA
2203-000854	C421	C-CER,CHIP	SA
2203-000854	C422	C-CER,CHIP	SA
2203-006562	C423	C-CER,CHIP	SA
2203-006562	C424	C-CER,CHIP	SA

SEC CODE	Design LOC	Discription	STATUS
2203-000812	C425	C-CER,CHIP	SA
2203-000812	C426	C-CER,CHIP	SA
2203-000812	C427	C-CER,CHIP	SA
2203-000812	C428	C-CER,CHIP	SA
2203-006562	C429	C-CER,CHIP	SA
2203-000311	C430	C-CER,CHIP	SA
2203-000330	C431	C-CER,CHIP	SA
2203-000940	C432	C-CER,CHIP	SA
2203-006562	C433	C-CER,CHIP	SA
2203-000330	C434	C-CER,CHIP	SA
2203-000940	C435	C-CER,CHIP	SA
2203-006556	C436	C-CER,CHIP	SA
2203-005736	C437	C-CER,CHIP	SA
2203-005717	C438	C-CER,CHIP	SA
2203-006462	C439	C-CER,CHIP	SA
2203-006194	C440	C-CER,CHIP	SA
2203-006462	C443	C-CER,CHIP	SA
2203-006462	C444	C-CER,CHIP	SA
2203-000628	C445	C-CER,CHIP	SA
2203-006562	C446	C-CER,CHIP	SA
2203-006562	C447	C-CER,CHIP	SA
2203-006423	C448	C-CER,CHIP	SA
2203-000940	C449	C-CER,CHIP	SA
2203-001405	C450	C-CER,CHIP	SA
2203-000654	C451	C-CER,CHIP	SA
2203-000278	C452	C-CER,CHIP	SA
2203-006562	C453	C-CER,CHIP	SA
2203-006462	C454	C-CER,CHIP	SA
2203-006423	C455	C-CER,CHIP	SA
2203-006423	C456	C-CER,CHIP	SA
2203-000940	C457	C-CER,CHIP	SA
2203-000278	C458	C-CER,CHIP	SA
2203-000654	C459	C-CER,CHIP	SA
2203-001405	C460	C-CER,CHIP	SA
2203-006562	C500	C-CER,CHIP	SA
2203-006562	C501	C-CER,CHIP	SA
2203-006423	C502	C-CER,CHIP	SA
2404-001339	C503	C-TA,CHIP	SA

Main Electrical Parts List

SEC CODE	Design LOC	Discription	STATUS
2203-006324	C504	C-CER,CHIP	SA
2203-006562	C505	C-CER,CHIP	SA
2203-006825	C506	C-CER,CHIP	SA
2203-006825	C507	C-CER,CHIP	SA
2203-005061	C508	C-CER,CHIP	SA
2203-005061	C509	C-CER,CHIP	SA
2203-006562	C510	C-CER,CHIP	SA
2203-006825	C511	C-CER,CHIP	SA
2203-006562	C512	C-CER,CHIP	SA
2203-006825	C513	C-CER,CHIP	SA
2203-006825	C514	C-CER,CHIP	SA
2203-006562	C516	C-CER,CHIP	SA
2203-006562	C517	C-CER,CHIP	SA
2203-002443	C518	C-CER,CHIP	SA
2203-002443	C519	C-CER,CHIP	SA
2203-000189	C601	C-CER,CHIP	SA
2203-005061	C602	C-CER,CHIP	SA
2203-005482	C604	C-CER,CHIP	SA
2203-005725	C700	C-CER,CHIP	SA
2703-001178	C701	INDUCTOR-SMD	SA
2203-000330	C704	C-CER,CHIP	SA
2203-006361	C705	C-CER,CHIP	SA
2203-006423	C706	C-CER,CHIP	SA
2203-005725	C707	C-CER,CHIP	SA
2203-006324	C708	C-CER,CHIP	SA
2203-006846	C710	C-CER,CHIP	SNA
2203-000812	C711	C-CER,CHIP	SA
2203-002677	C712	C-CER,CHIP	SA
2203-006361	C713	C-CER,CHIP	SA
2203-006423	C715	C-CER,CHIP	SA
2203-006194	C716	C-CER,CHIP	SA
2203-005682	C717	C-CER,CHIP	SA
2203-006121	C718	C-CER,CHIP	SA
2203-006305	C719	C-CER,CHIP	SA
2203-006305	C720	C-CER,CHIP	SA
2203-000311	C722	C-CER,CHIP	SA
2203-005736	C723	C-CER,CHIP	SA

SEC CODE	Design LOC	Discription	STATUS
2203-006194	C724	C-CER,CHIP	SA
2203-006194	C725	C-CER,CHIP	SA
2203-006305	C728	C-CER,CHIP	SA
2203-005682	C731	C-CER,CHIP	SA
2203-006423	C732	C-CER,CHIP	SA
2203-006562	C733	C-CER,CHIP	SA
2203-006562	C734	C-CER,CHIP	SA
2203-006194	C735	C-CER,CHIP	SA
2203-006048	C736	C-CER,CHIP	SA
2203-006562	C737	C-CER,CHIP	SA
2203-006048	C738	C-CER,CHIP	SA
2203-006194	C739	C-CER,CHIP	SA
0407-000115	D1	DIODE-ARRAY	SA
0404-001245	D2	DIODE-SCHOTTKY	SA
0403-001547	D201	DIODE-ZENER	SA
3722-002082	EAR401	JACK-PHONE	SA
2901-001286	F501	FILTER-EMI SMD	SA
2901-001286	F502	FILTER-EMI SMD	SA
2901-001286	F503	FILTER-EMI SMD	SA
2901-001286	F504	FILTER-EMI SMD	SA
2901-001286	F505	FILTER-EMI SMD	SA
2901-001286	F506	FILTER-EMI SMD	SA
2901-001286	F507	FILTER-EMI SMD	SA
2911-000034	F700	DUPLEXER-FEM	SA
2901-001256	F704	FILTER-EMI SMD	SA
3711-005643	HDC2	HEADER-BOARD TO BOARD	SA
3710-001611	IFC601	CONNECTOR-INTERFACE	SA
3301-001342	L400	BEAD-SMD	SA
3301-001534	L401	BEAD-SMD	SA
3301-001342	L402	BEAD-SMD	SA
3301-001342	L403	BEAD-SMD	SA
2703-002989	L404	INDUCTOR-SMD	SA
2703-001231	L405	INDUCTOR-SMD	SA
2703-002313	L406	INDUCTOR-SMD	SA
2703-002910	L408	INDUCTOR-SMD	SA
2703-002313	L409	INDUCTOR-SMD	SA
3301-001342	L410	BEAD-SMD	SA
3301-001729	L500	BEAD-SMD	SA

Main Electrical Parts List

SEC CODE	Design LOC	Discription	STATUS
2703-001242	L501	INDUCTOR-SMD	SA
2703-001242	L502	INDUCTOR-SMD	SA
GH71-05809A	L700	NPR-ANTENNA CONTACT V2	SA
GH71-05809A	L701	NPR-ANTENNA CONTACT V2	SA
2703-002910	L702	INDUCTOR-SMD	SA
2203-005281	L703	C-CER,CHIP	SA
2703-002597	L704	INDUCTOR-SMD	SA
2703-002597	L705	INDUCTOR-SMD	SA
2703-002636	L706	INDUCTOR-SMD	SA
2703-002636	L707	INDUCTOR-SMD	SA
2703-002700	L708	INDUCTOR-SMD	SA
2703-002700	L709	INDUCTOR-SMD	SA
3301-001208	L710	BEAD-SMD	SA
0601-002160	LED501	LED	SA
0601-002160	LED502	LED	SA
2801-004466	OSC202	CRYSTAL-SMD	SA
2801-004458	OSC301	CRYSTAL-SMD	SA
2801-004552	OSC700	CRYSTAL-SMD	SA
1201-002368	PAM101	IC-POWER AMP	SA
1203-003432	Q700	IC-POSI.FIXED REG.	SA
2007-000162	R100	R-CHIP	SA
2007-009169	R101	R-CHIP	SA
2007-009160	R102	R-CHIP	SA
2007-000982	R103	R-CHIP	SA
2007-007308	R104	R-CHIP	SA
2007-007314	R105	R-CHIP	SA
2007-008052	R106	R-CHIP	SA
2007-008055	R107	R-CHIP	SA
2007-008055	R108	R-CHIP	SA
2007-009170	R109	R-CHIP	SA
2007-000138	R111	R-CHIP	SA
2007-008542	R112	R-CHIP	SA
2007-000157	R113	R-CHIP	SA
2007-000146	R200	R-CHIP	SA
2007-008055	R201	R-CHIP	SA
2007-008542	R202	R-CHIP	SA
2007-008542	R203	R-CHIP	SA

SEC CODE	Design LOC	Discription	STATUS
2007-008542	R204	R-CHIP	SA
2007-008542	R205	R-CHIP	SA
2007-000162	R206	R-CHIP	SA
2007-008516	R207	R-CHIP	SA
2007-000157	R208	R-CHIP	SA
2007-007528	R209	R-CHIP	SA
2007-000139	R210	R-CHIP	SA
2007-000139	R211	R-CHIP	SA
2007-001292	R212	R-CHIP	SA
2007-001292	R213	R-CHIP	SA
2007-008542	R214	R-CHIP	SA
2007-001284	R215	R-CHIP	SA
2007-000143	R301	R-CHIP	SA
2007-000143	R302	R-CHIP	SA
2007-008055	R303	R-CHIP	SA
2007-000171	R304	R-CHIP	SA
2007-008055	R305	R-CHIP	SA
2007-008055	R306	R-CHIP	SA
2007-008483	R307	R-CHIP	SA
2007-009124	R308	R-CHIP	SA
2007-000170	R309	R-CHIP	SA
2007-000171	R400	R-CHIP	SA
2007-007306	R401	R-CHIP	SA
2007-000137	R402	R-CHIP	SA
2007-008647	R403	R-CHIP	SA
2007-008647	R404	R-CHIP	SA
2007-000171	R405	R-CHIP	SA
2007-000171	R406	R-CHIP	SA
2007-000157	R407	R-CHIP	SA
2007-000148	R408	R-CHIP	SA
2007-000171	R409	R-CHIP	SA
2007-000148	R410	R-CHIP	SA
2007-000148	R411	R-CHIP	SA
2007-000172	R412	R-CHIP	SA
2007-000171	R413	R-CHIP	SA
2007-000171	R414	R-CHIP	SA
2007-000172	R415	R-CHIP	SA
2007-000171	R416	R-CHIP	SA

Main Electrical Parts List

SEC CODE	Design LOC	Discription	STATUS
2007-000171	R417	R-CHIP	SA
2007-007142	R418	R-CHIP	SA
2007-000161	R419	R-CHIP	SA
2007-007142	R420	R-CHIP	SA
2007-000161	R421	R-CHIP	SA
2007-000141	R422	R-CHIP	SA
2007-000141	R423	R-CHIP	SA
2007-000139	R424	R-CHIP	SA
2007-009170	R427	R-CHIP	SA
2007-009170	R428	R-CHIP	SA
2007-000171	R429	R-CHIP	SA
2007-000141	R430	R-CHIP	SA
2007-000141	R431	R-CHIP	SA
2007-008478	R432	R-CHIP	SA
2007-008478	R433	R-CHIP	SA
2007-008786	R434	R-CHIP	SA
2007-009154	R435	R-CHIP	SNA
2007-007142	R436	R-CHIP	SA
2007-008051	R437	R-CHIP	SA
2007-000159	R438	R-CHIP	SA
2007-007142	R440	R-CHIP	SA
2007-008055	R441	R-CHIP	SA
2007-000159	R442	R-CHIP	SA
2007-000140	R443	R-CHIP	SA
2007-009233	R500	R-CHIP	SA
2007-008483	R501	R-CHIP	SA
2007-000171	R502	R-CHIP	SA
2007-008542	R503	R-CHIP	SA
2007-008052	R504	R-CHIP	SA
2007-001288	R505	R-CHIP	SA
2007-001288	R506	R-CHIP	SA
2007-008542	R507	R-CHIP	SA
2007-000171	R508	R-CHIP	SA
2007-008040	R600	R-CHIP	SA
2007-008483	R601	R-CHIP	SA
2007-008040	R602	R-CHIP	SA
2007-008040	R603	R-CHIP	SA

SEC CODE	Design LOC	Discription	STATUS
2007-008040	R604	R-CHIP	SA
2007-008040	R605	R-CHIP	SA
2007-008419	R608	R-CHIP	SA
2007-008419	R609	R-CHIP	SA
2007-008419	R610	R-CHIP	SA
2007-008419	R611	R-CHIP	SA
2007-008419	R612	R-CHIP	SA
2007-008516	R613	R-CHIP	SA
2007-008040	R614	R-CHIP	SA
2007-008040	R615	R-CHIP	SA
2007-008040	R616	R-CHIP	SA
2007-008040	R617	R-CHIP	SA
2007-008040	R618	R-CHIP	SA
2203-001259	R700	C-CER,CHIP	SA
2007-001290	R702	R-CHIP	SA
2007-000139	R703	R-CHIP	SA
2007-000139	R704	R-CHIP	SA
2007-008542	R705	R-CHIP	SA
2007-008588	R706	R-CHIP	SA
2703-002793	R707	INDUCTOR-SMD	SA
2007-008542	R708	R-CHIP	SA
2007-008542	R709	R-CHIP	SA
2007-007741	R712	R-CHIP	SA
2007-008516	R713	R-CHIP	SA
2007-007134	R714	R-CHIP	SA
2007-008587	R721	R-CHIP	SA
2007-008542	R723	R-CHIP	SA
2007-008045	R724	R-CHIP	SA
2007-009314	R725	R-CHIP	SA
2007-008800	R727	R-CHIP	SA
2007-000157	R728	R-CHIP	SA
2007-008542	R729	R-CHIP	SA
2007-008542	R730	R-CHIP	SA
3705-001358	RFS701	CONNECTOR-COAXIAL	SA
3709-001451	SIM101	CONNECTOR-CARD EDGE	SA
3708-002162	SLC1	CONNECTOR-FPC/FFC/PIC	SA
3710-002081	SOC3	SOCKET-BOARD TO BOARD	SA
3710-002081	SOC4	SOCKET-BOARD TO BOARD	SA



Main Electrical Parts List

SEC CODE	Design LOC	Discription	STATUS
2404-001381	TA103	C-TA,CHIP	SA
2404-001381	TA112	C-TA,CHIP	SA
2404-001225	TA114	C-TA,CHIP	SA
2404-001381	TA301	C-TA,CHIP	SA
2404-001225	TA401	C-TA,CHIP	SA
2404-001348	TA407	C-TA,CHIP	SA
2404-001225	TA408	C-TA,CHIP	SA
2404-001225	TA412	C-TA,CHIP	SA
2404-001381	TA416	C-TA,CHIP	SA
2404-001348	TA417	C-TA,CHIP	SA
2404-001151	TA442	C-TA,CHIP	SA
2404-001406	TA603	C-TA,CHIP	SA
1404-001165	TH101	THERMISTOR-NTC	SA
1203-003663	U101	IC-BATTERY	SA
0801-002529	U103	IC-CMOS LOGIC	SA
0801-002958	U104	IC-CMOS LOGIC	SA
1205-002272	U202	IC-TRANSCEIVER	SA
GH13-00036A	U302	IC ASIC-SGHX670	SA
1203-003585	U303	IC-POSI.FIXED REG.	SA
0801-002975	U304	IC-CMOS LOGIC	SA
1201-002233	U401	IC-AUDIO AMP	SA
1001-001306	U403	IC-ANALOG MULTIPLEX	SA
1204-002398	U404	IC-DEMODULATOR	SA
1203-003058	U501	IC-POSI.FIXED REG.	SA
1203-004164	U502	IC-DC/DC CONVERTER	SA
1203-003708	U504	IC-DC/DC CONVERTER	SNA
4709-001374	U755	BLUETOOTH MODULE	SA
1205-002944	UCD100	IC-TRANSCEIVER	SA
1203-004119	UCD102	IC-POWER SUPERVISOR	SA
1002-001441	UCD402	IC-D/A CONVERTER	SA
GH09-00044A	UCP201	IC MICOM	SA
1108-000068	UME753	IC-MCP	SA
1405-001108	V401	VARISTOR	SA
1405-001108	V404	VARISTOR	SA
0406-001223	V501	DIODE-TVS	SA
1405-001108	VR215	VARISTOR	SA
1405-001108	VR505	VARISTOR	SA

SEC CODE	Design LOC	Discription	STATUS
1405-001108	VR506	VARISTOR	SA
1405-001108	VR507	VARISTOR	SA
1405-001108	VR508	VARISTOR	SA
1405-001108	VR509	VARISTOR	SA
1405-001108	VR510	VARISTOR	SA
1405-001108	VR511	VARISTOR	SA
1405-001108	VR515	VARISTOR	SA
1405-001108	VR516	VARISTOR	SA
1405-001108	VR517	VARISTOR	SA
1405-001108	VR518	VARISTOR	SA
1405-001108	VR520	VARISTOR	SA
1405-001082	VR602	VARISTOR	SA
1405-001082	VR603	VARISTOR	SA
0406-001208	ZD401	DIODE-TVS	SA
0406-001150	ZD402	DIODE-TVS	SA
0406-001150	ZD403	DIODE-TVS	SA
0406-001150	ZD404	DIODE-TVS	SA
0406-001208	ZD501	DIODE-TVS	SA
1405-001108	ZD519	VARISTOR	SA
0403-001547	ZD601	DIODE-ZENER	SA
0406-001208	ZD604	DIODE-TVS	SA
0406-001208	ZD605	DIODE-TVS	SA

# 8. Block Diagrams

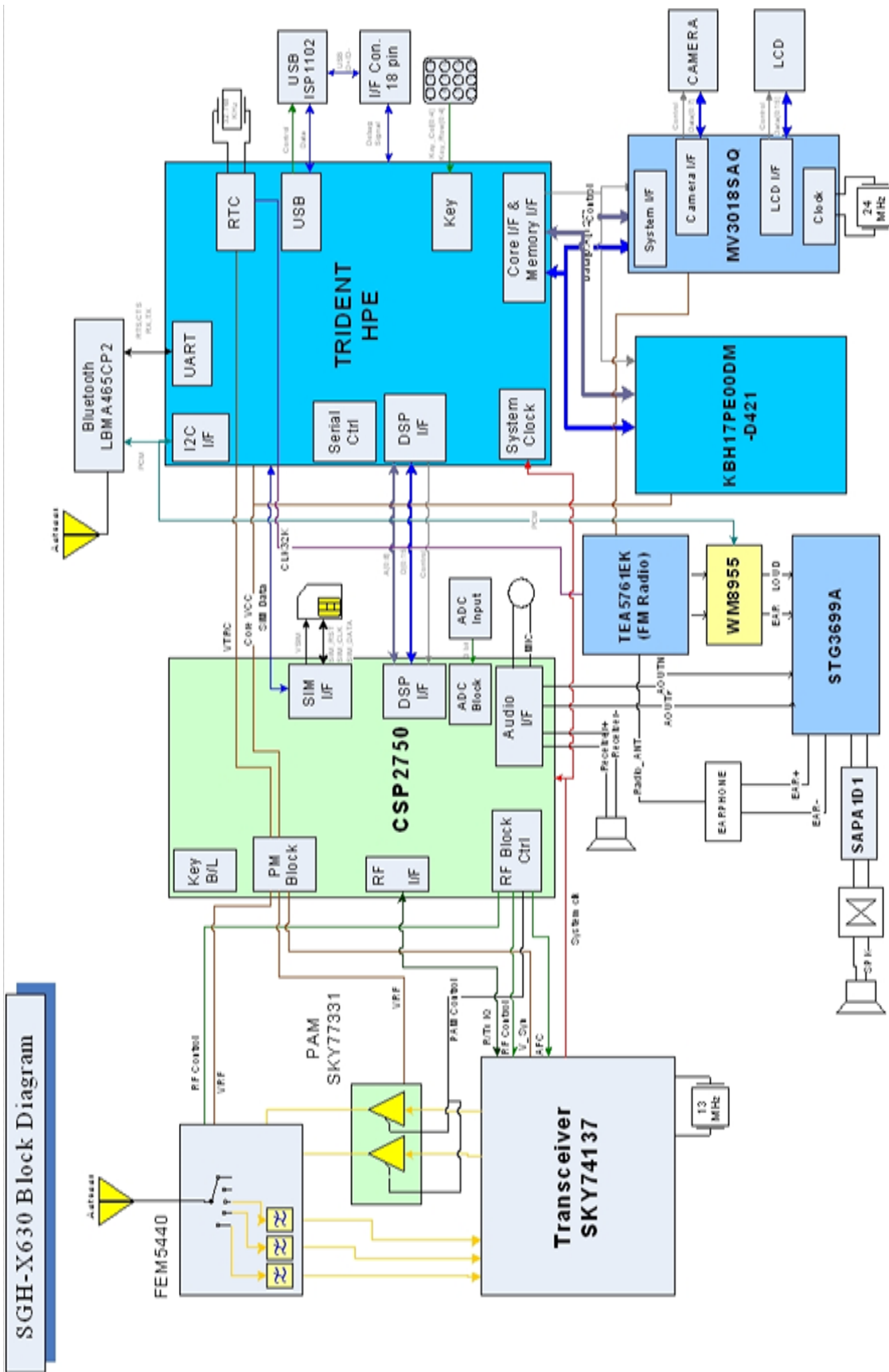

# 9. PCB Diagrams

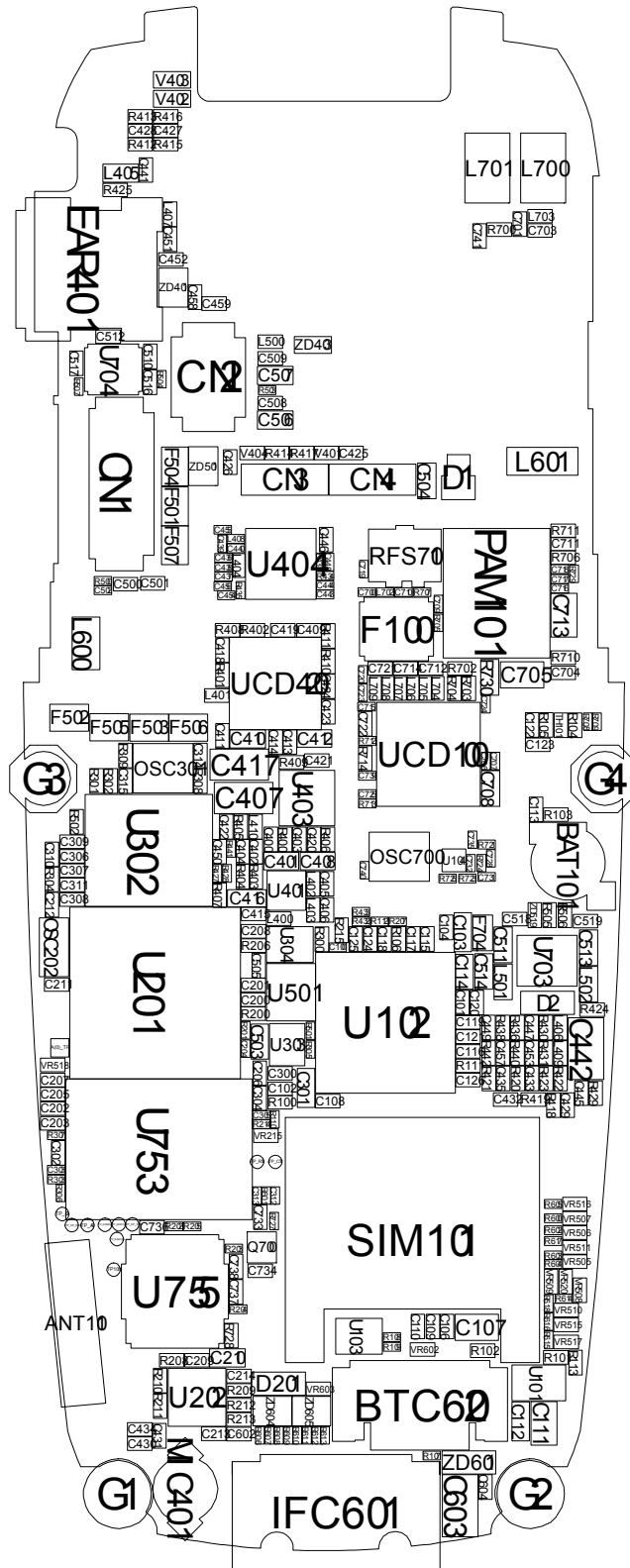

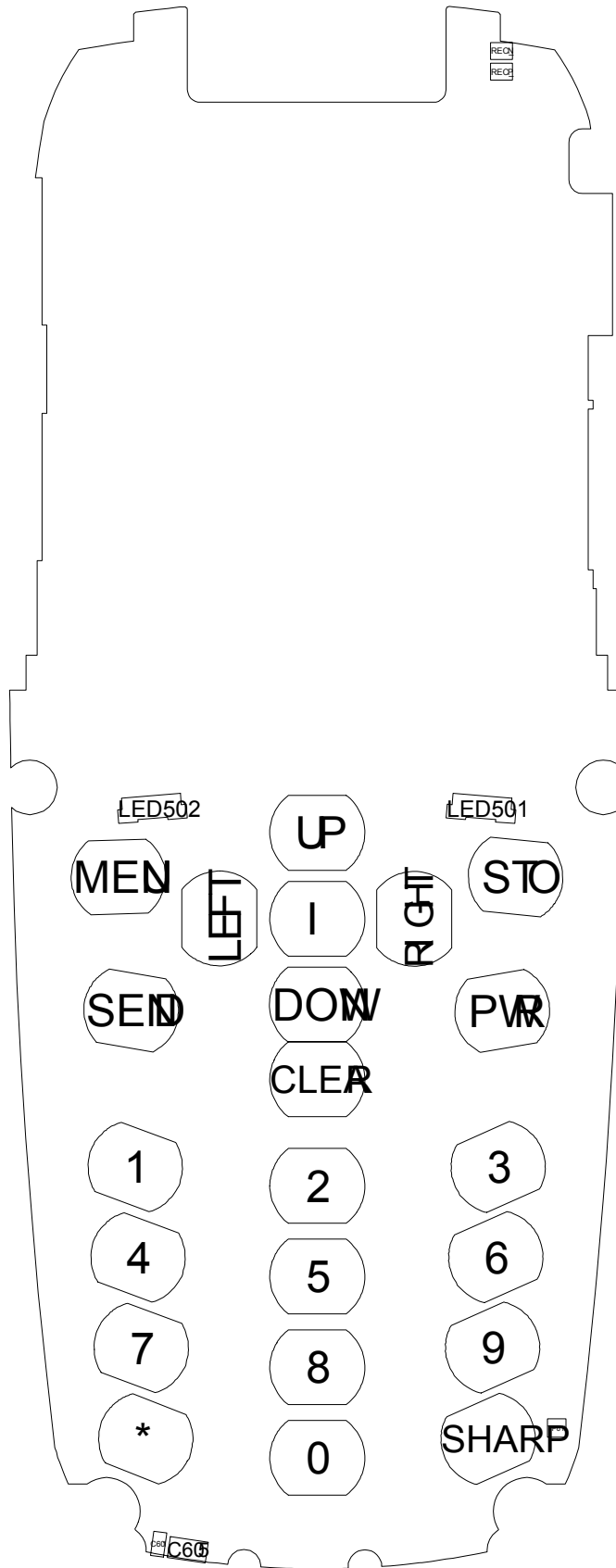

# 10. Flow Chart of Troubleshooting

## 10-1. Baseband

### 10-1-1. Power ON

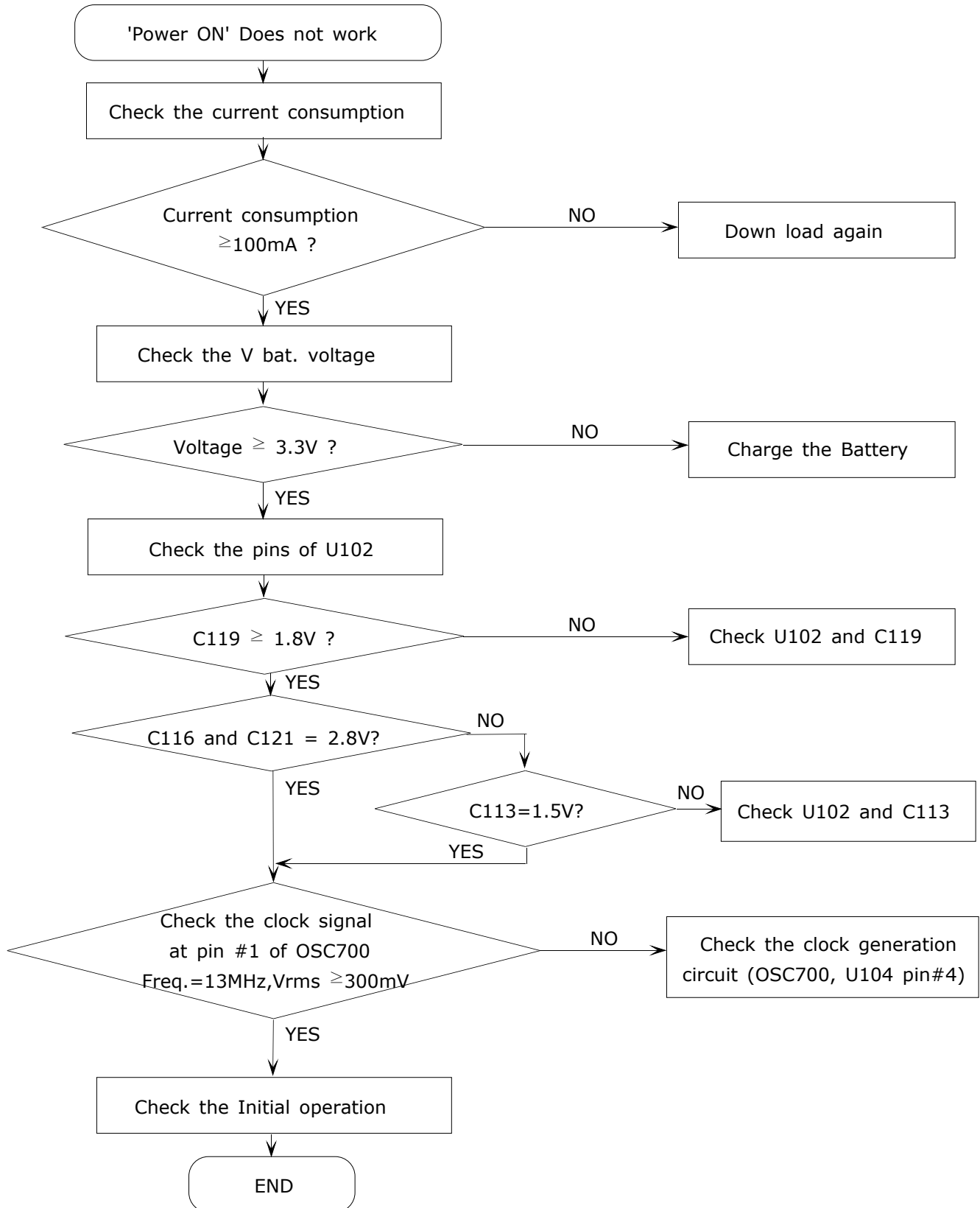



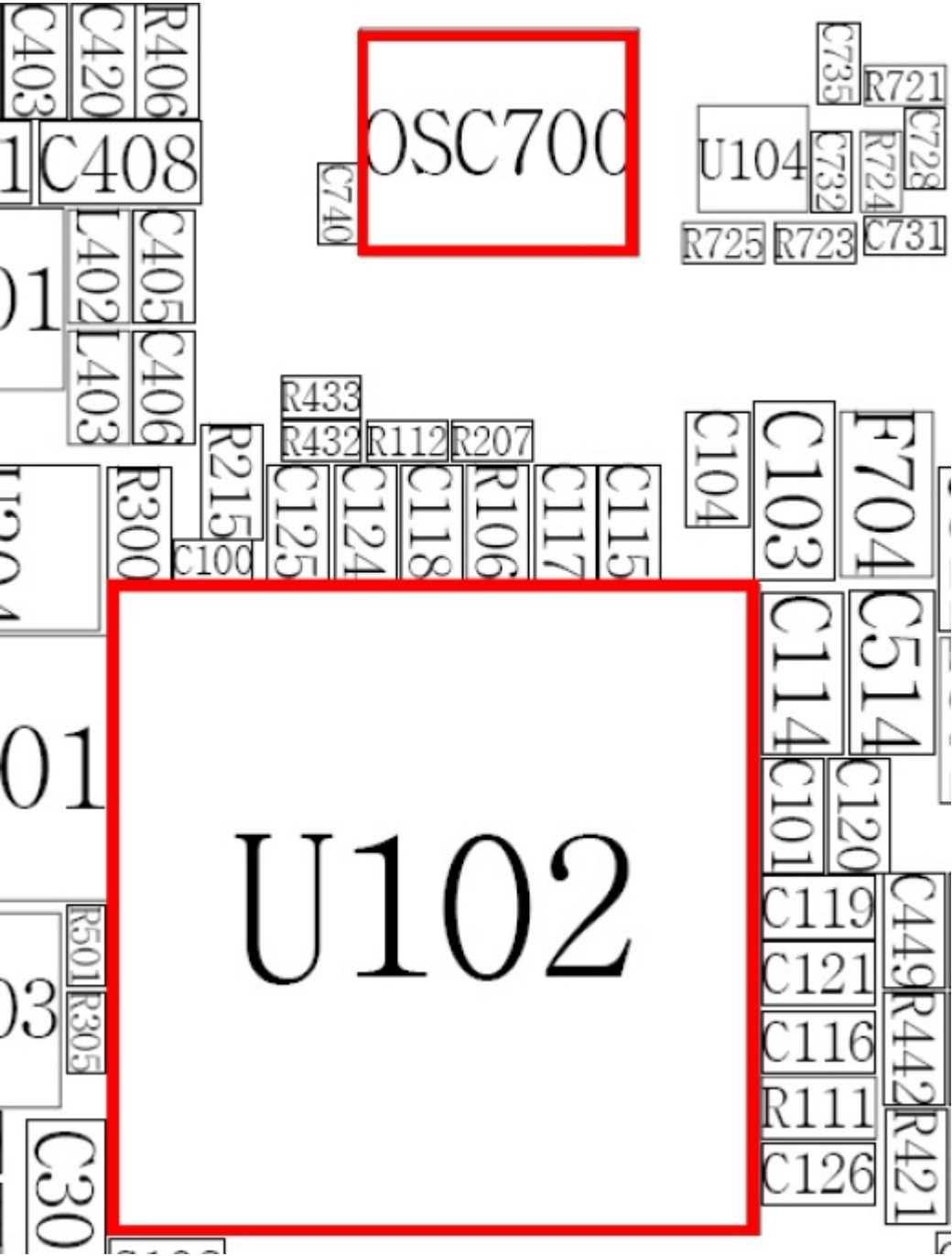



### 10-1-2. Initial

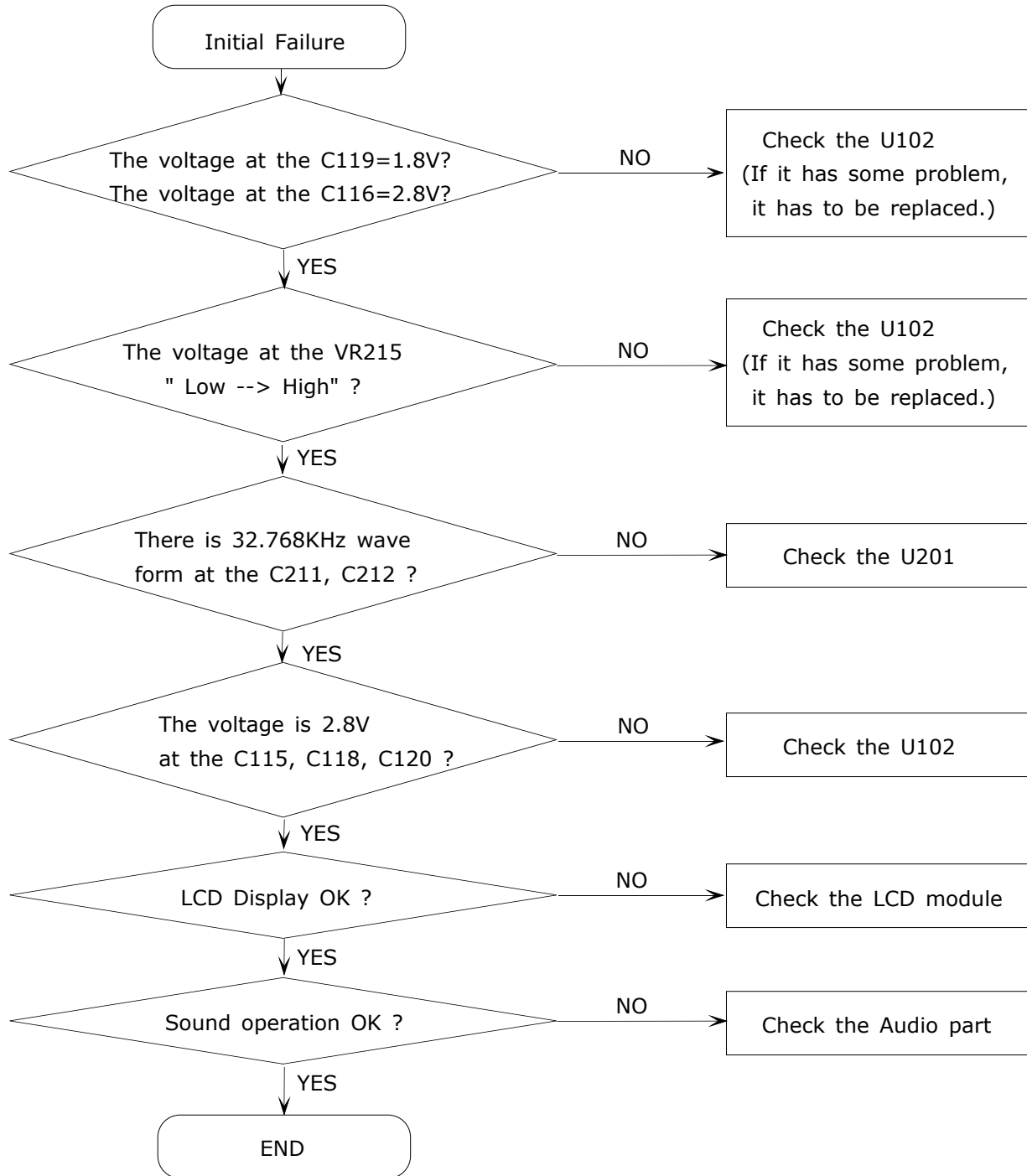



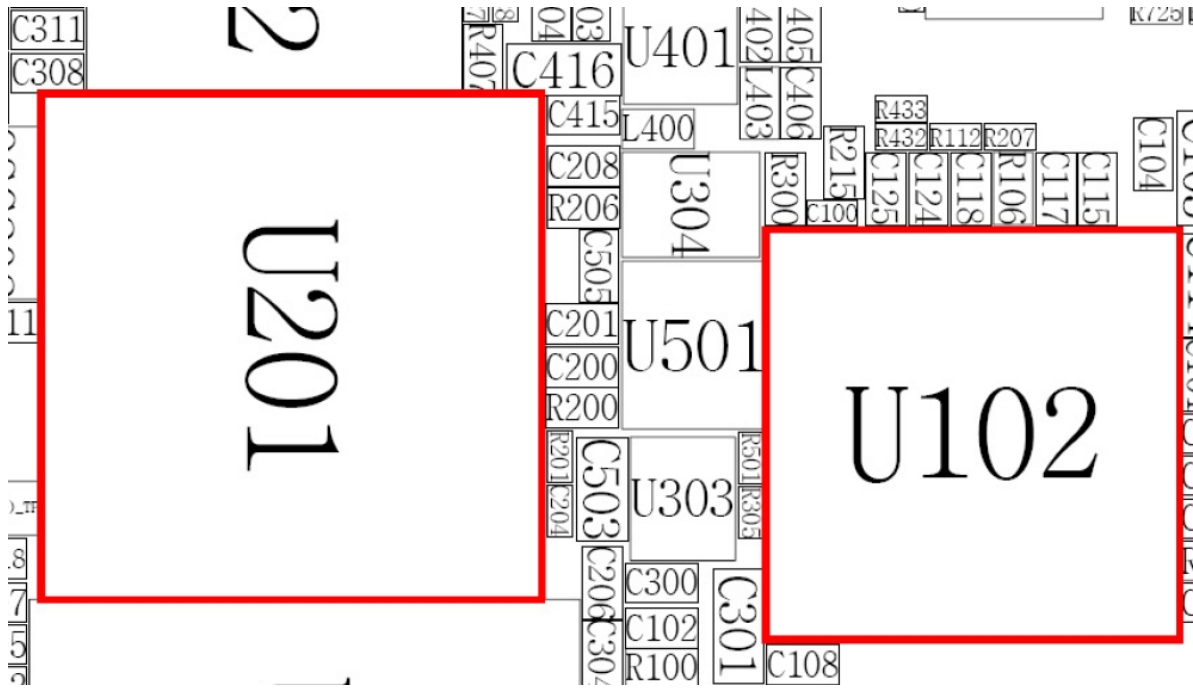

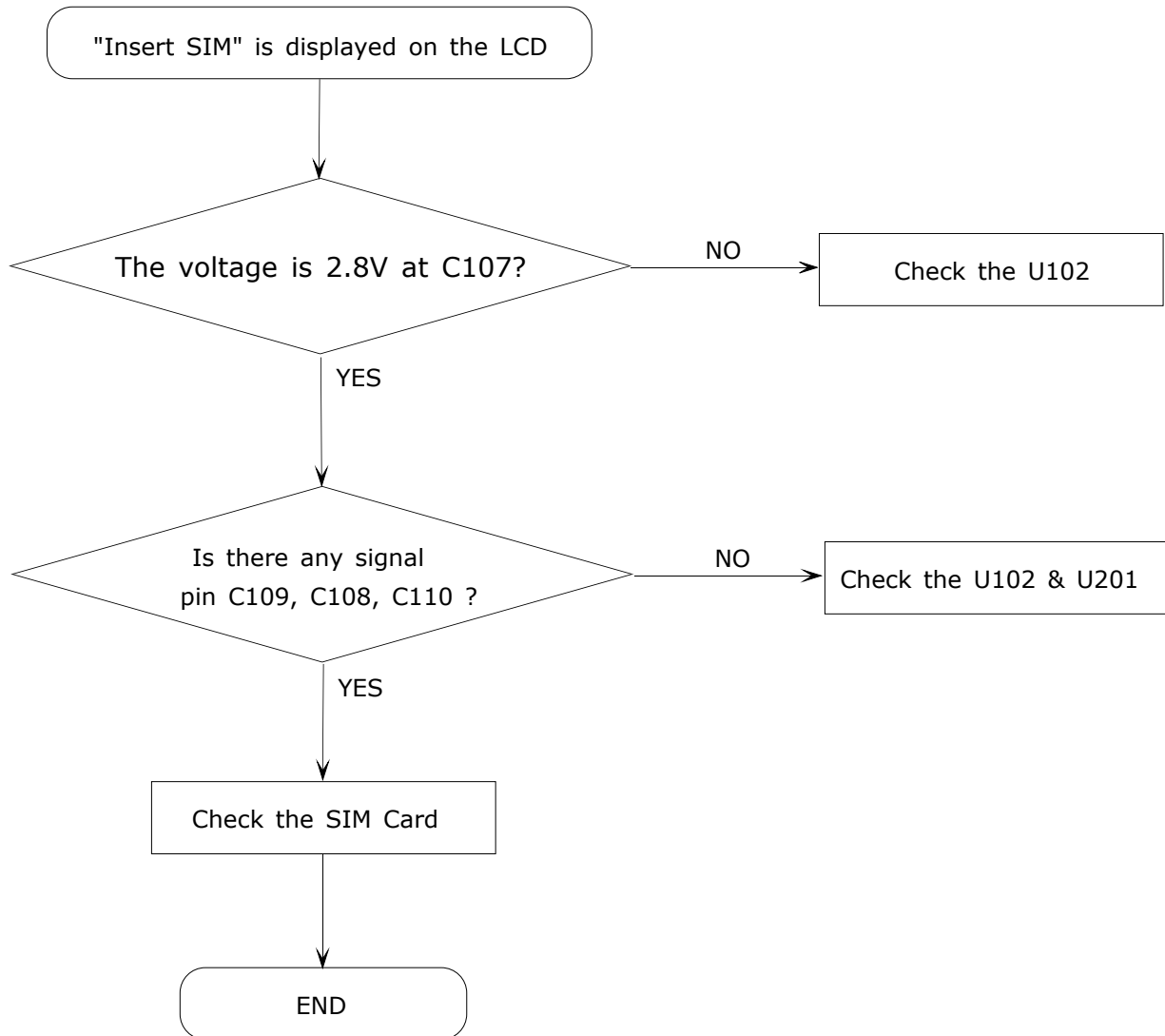
**10-1-3. Sim Part**

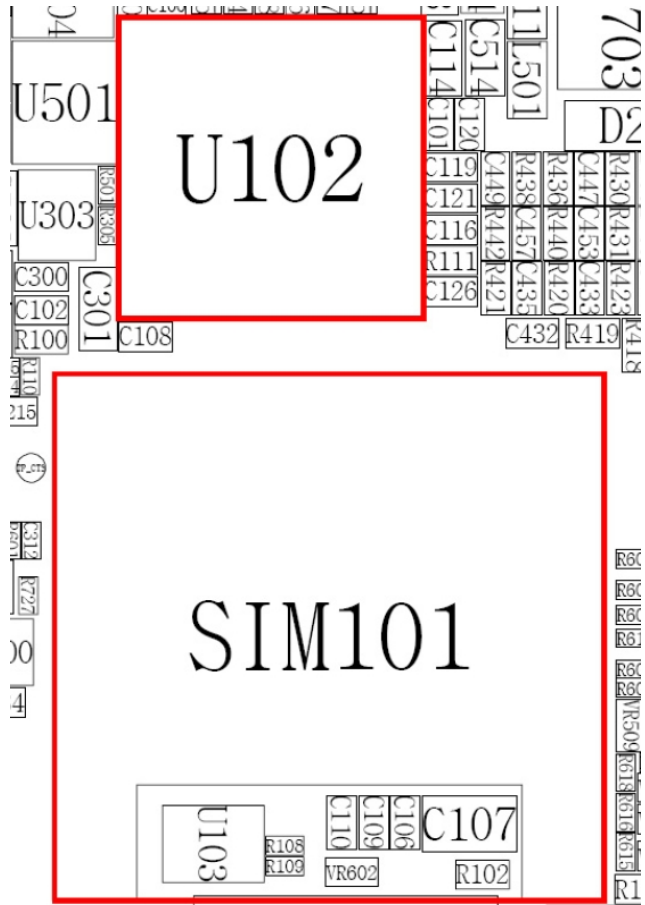
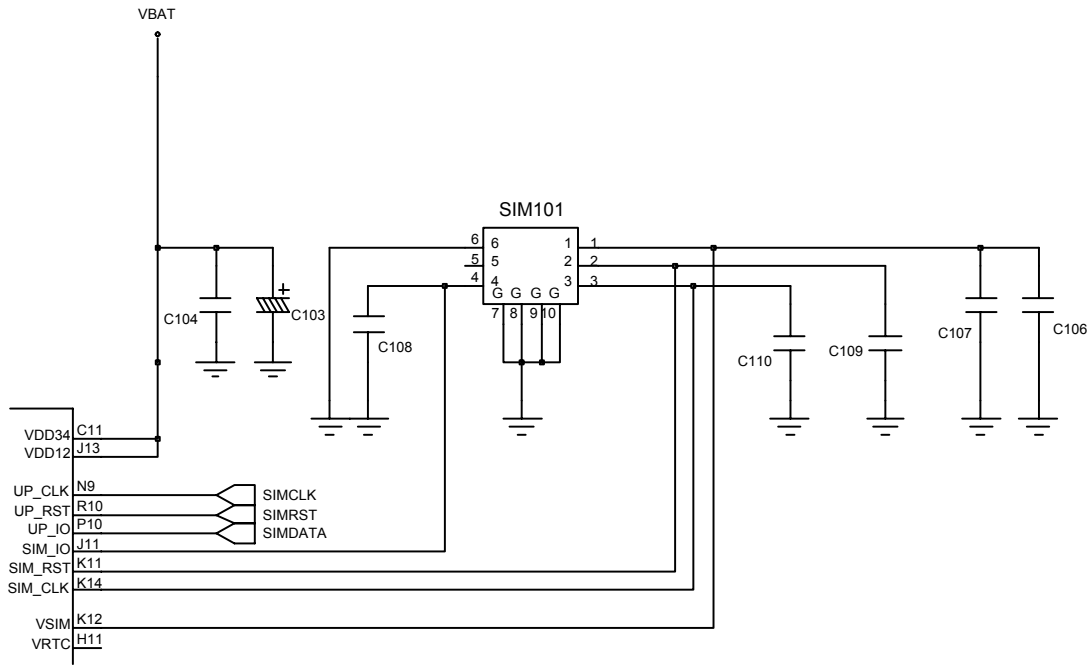

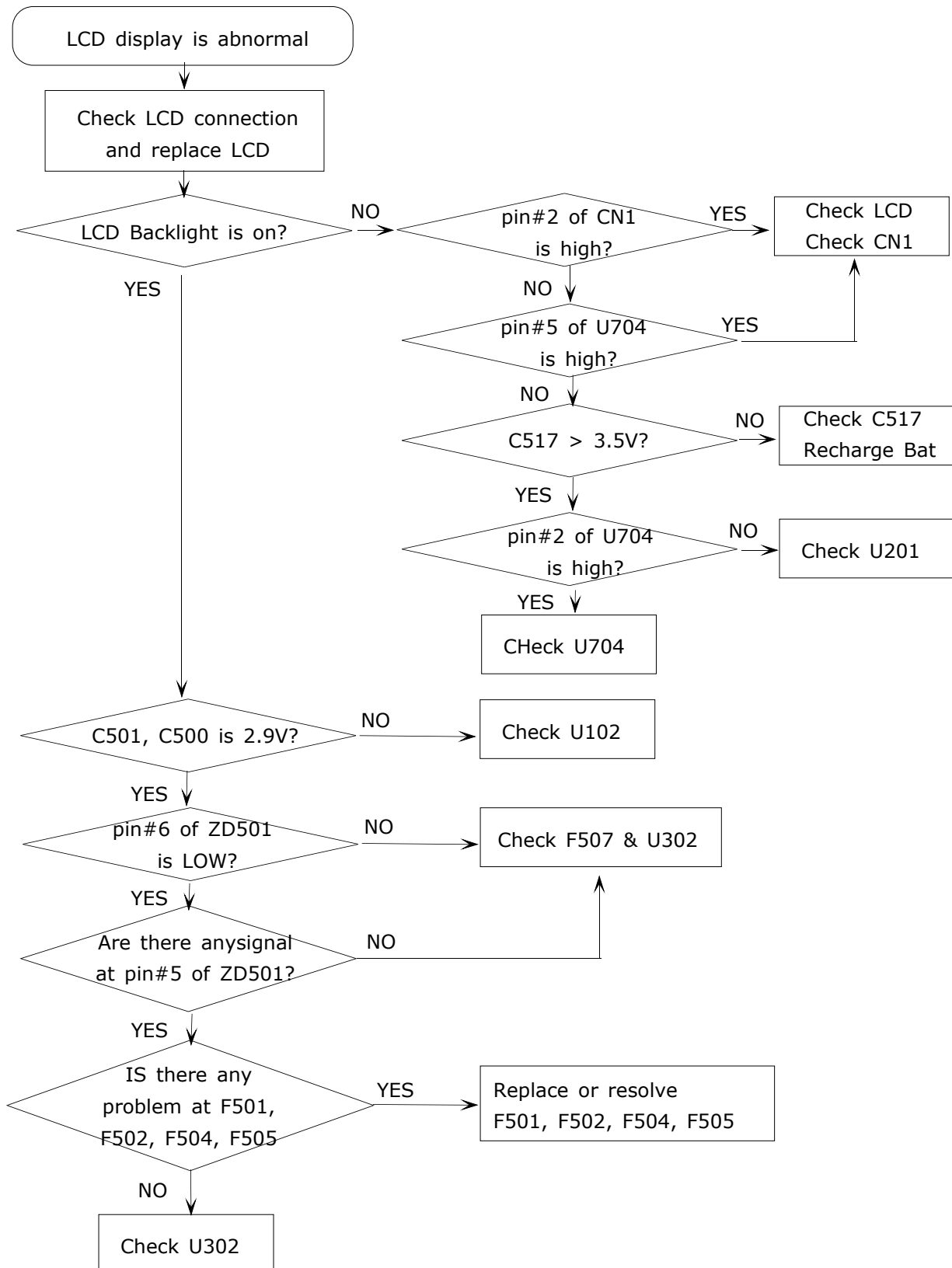
**10-1-4. LCD Display part**

# Flow Chart of Troubleshooting

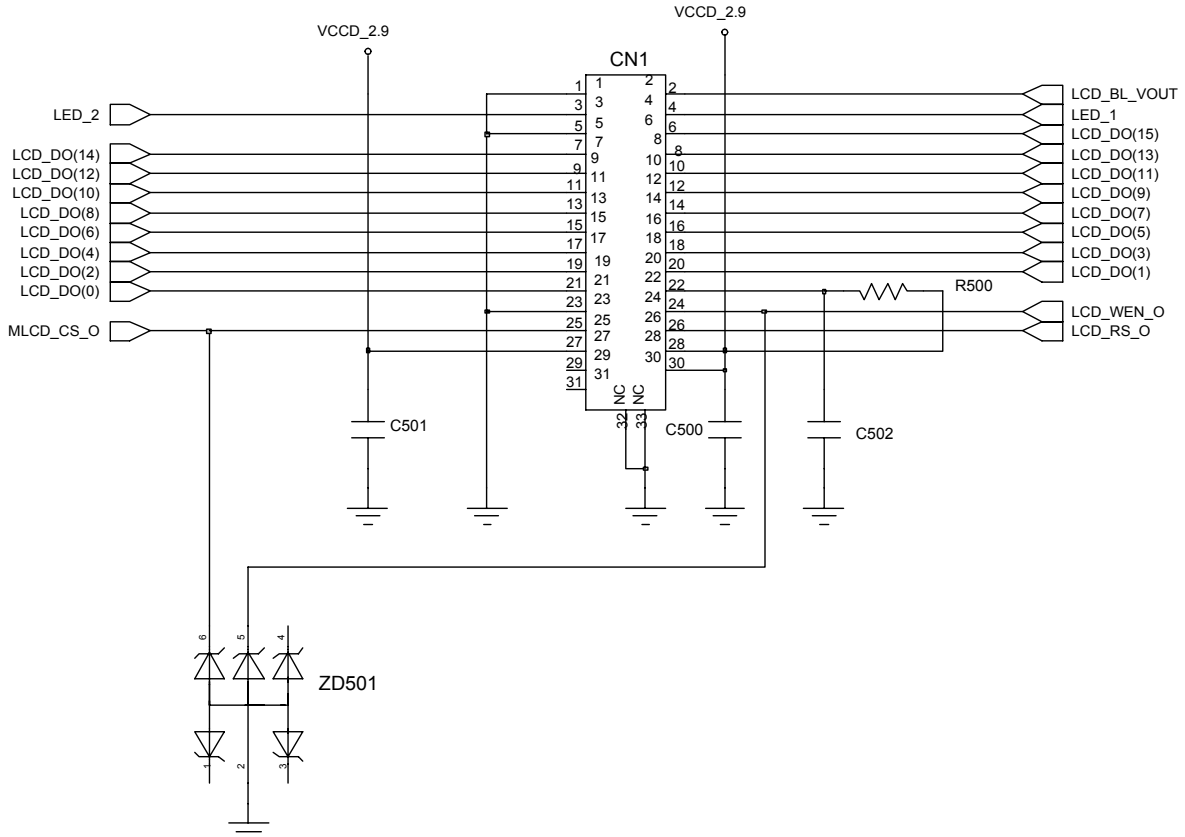
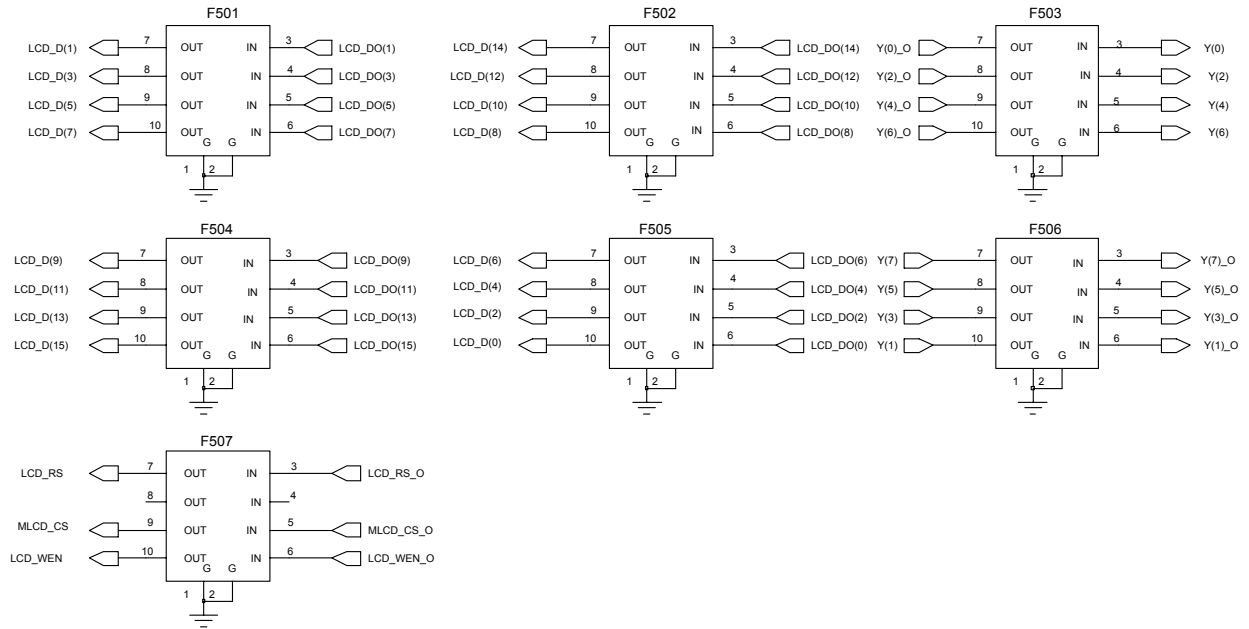

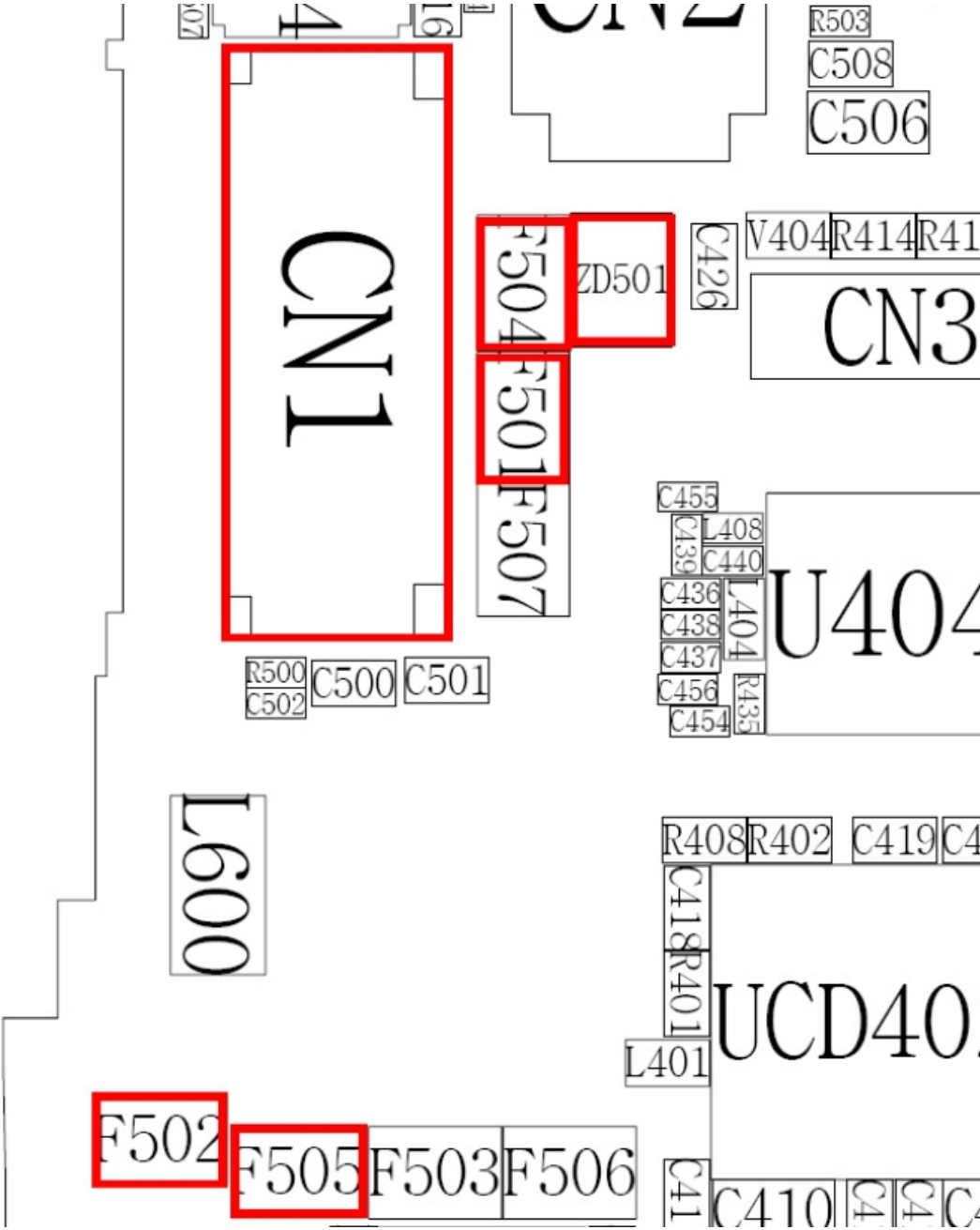



### 10-1-5. Microphone Part

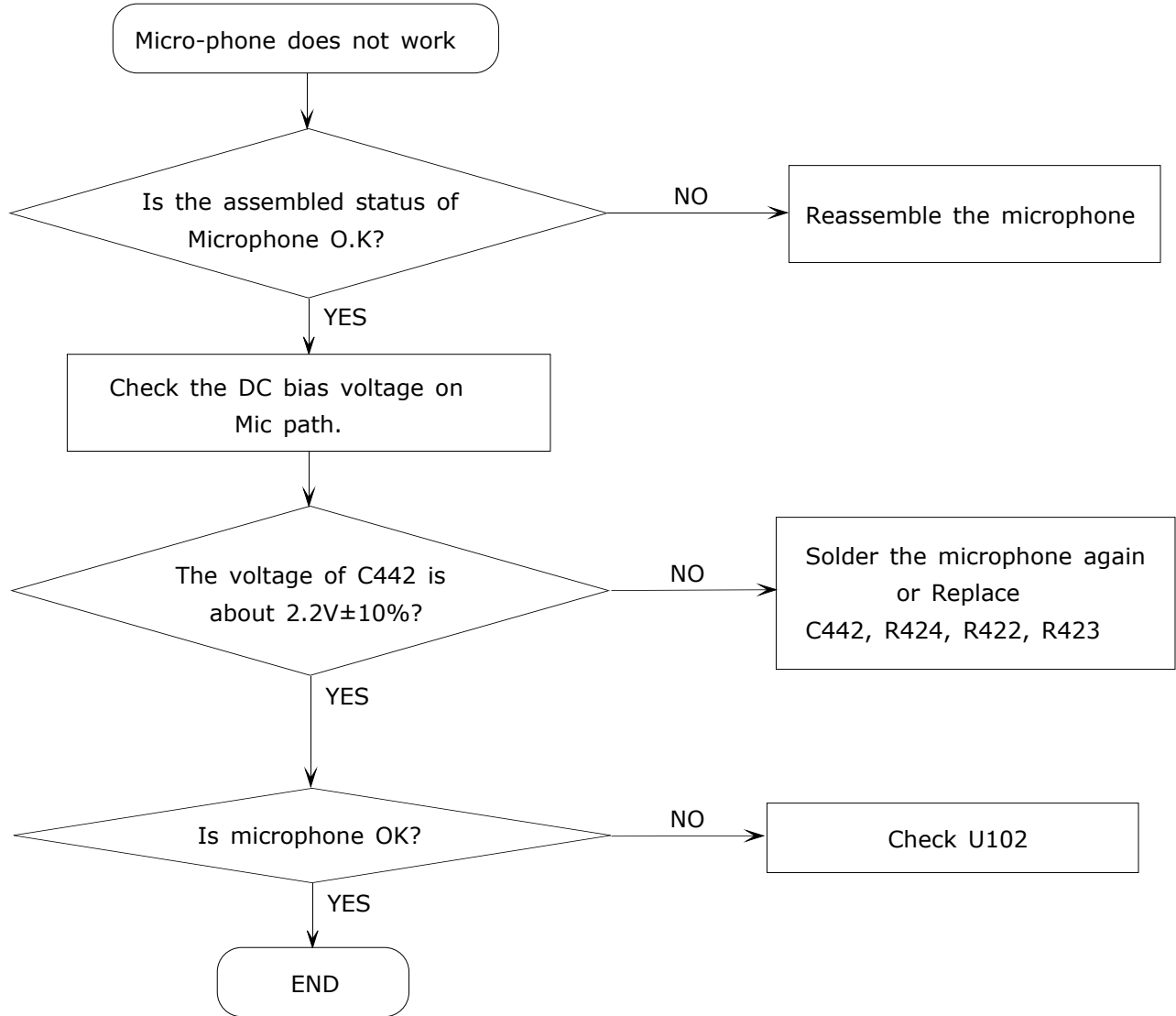

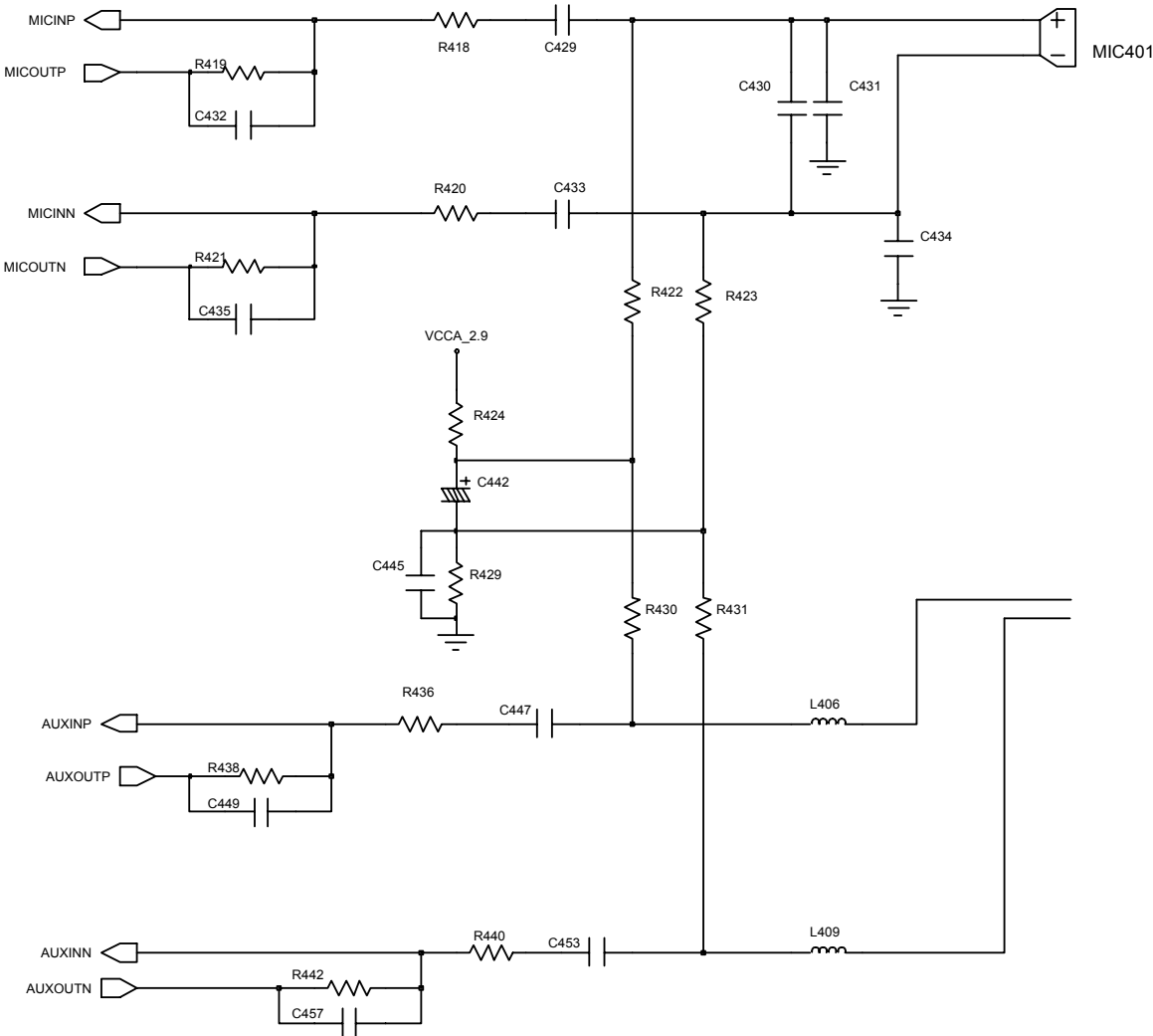

Flow Chart of Troubleshooting

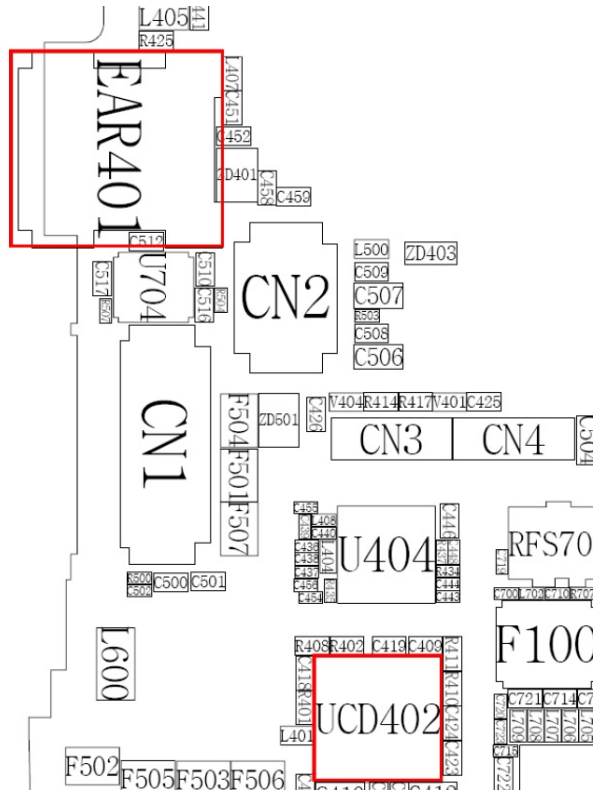
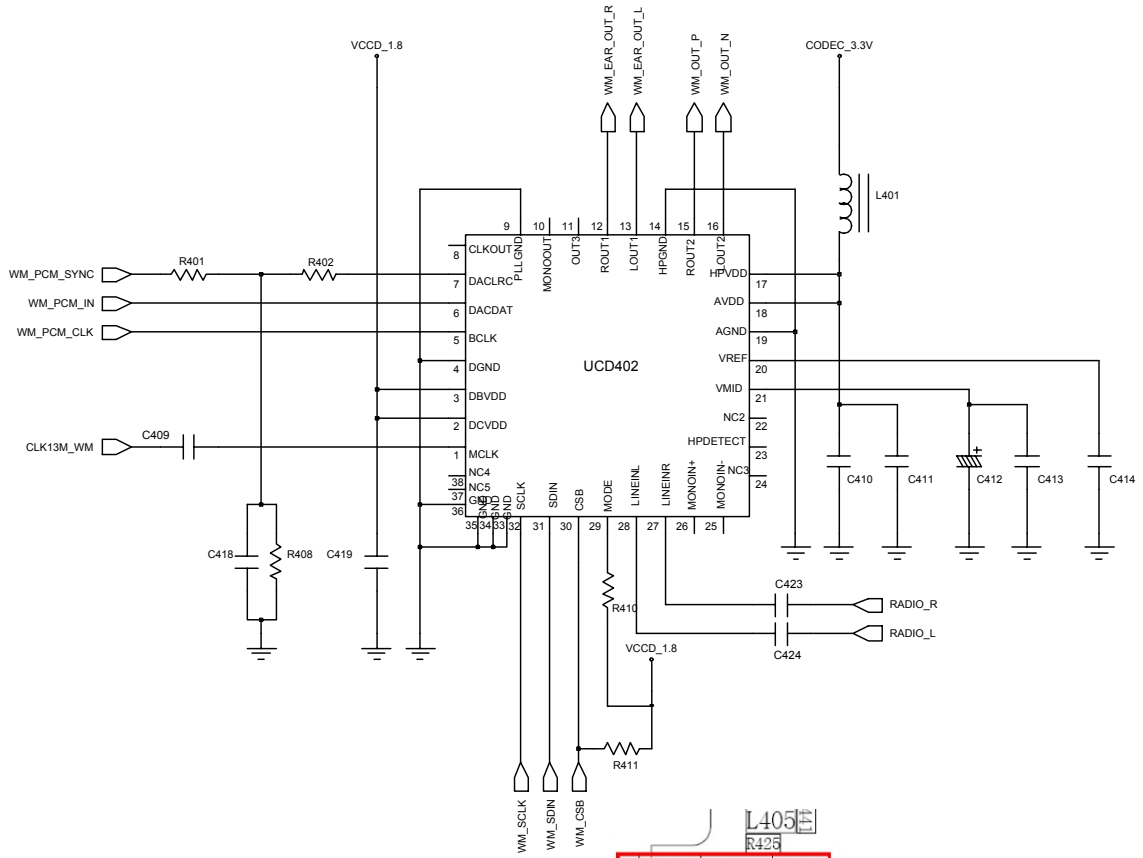

### 10-1-6. Speaker Part

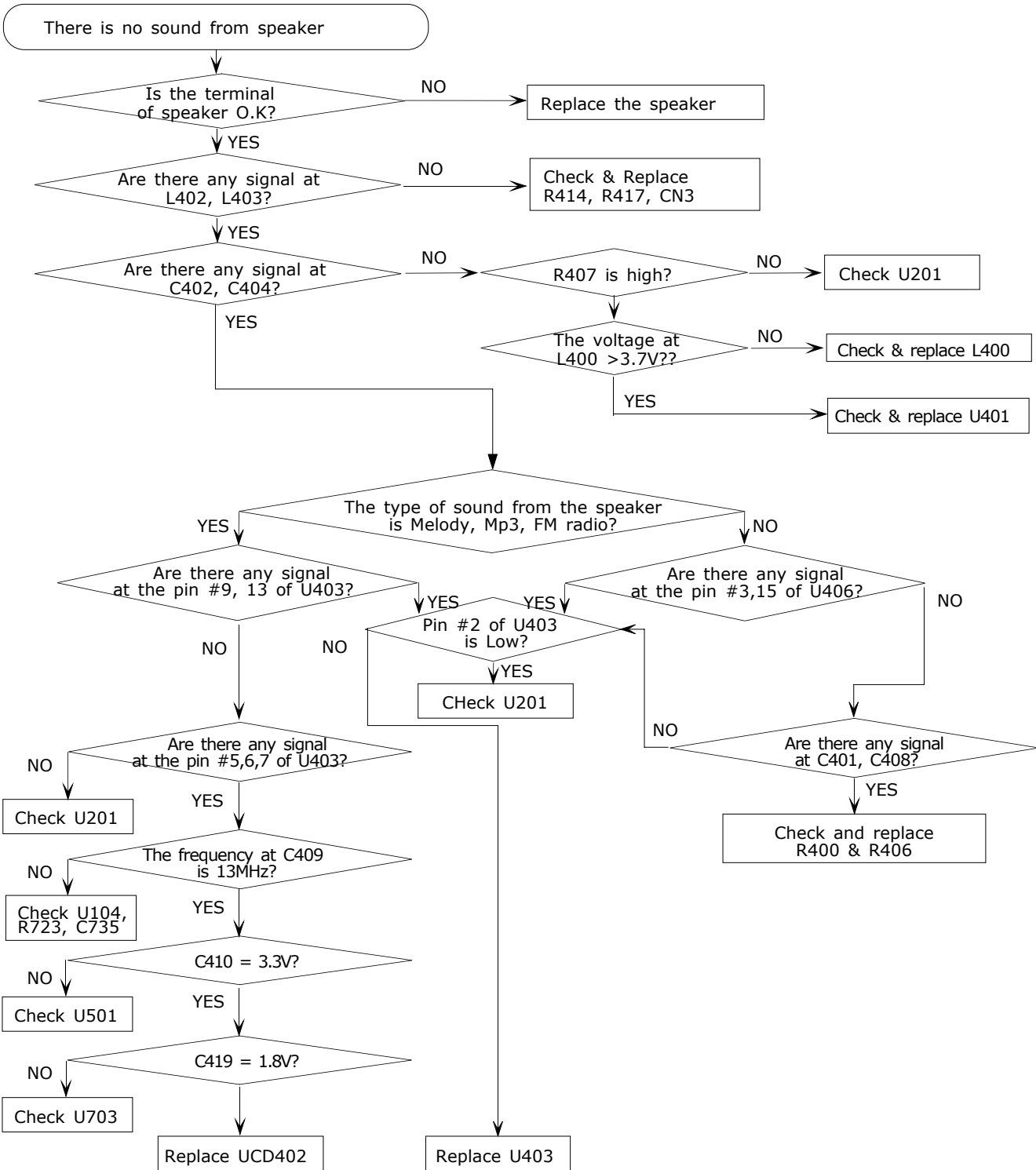

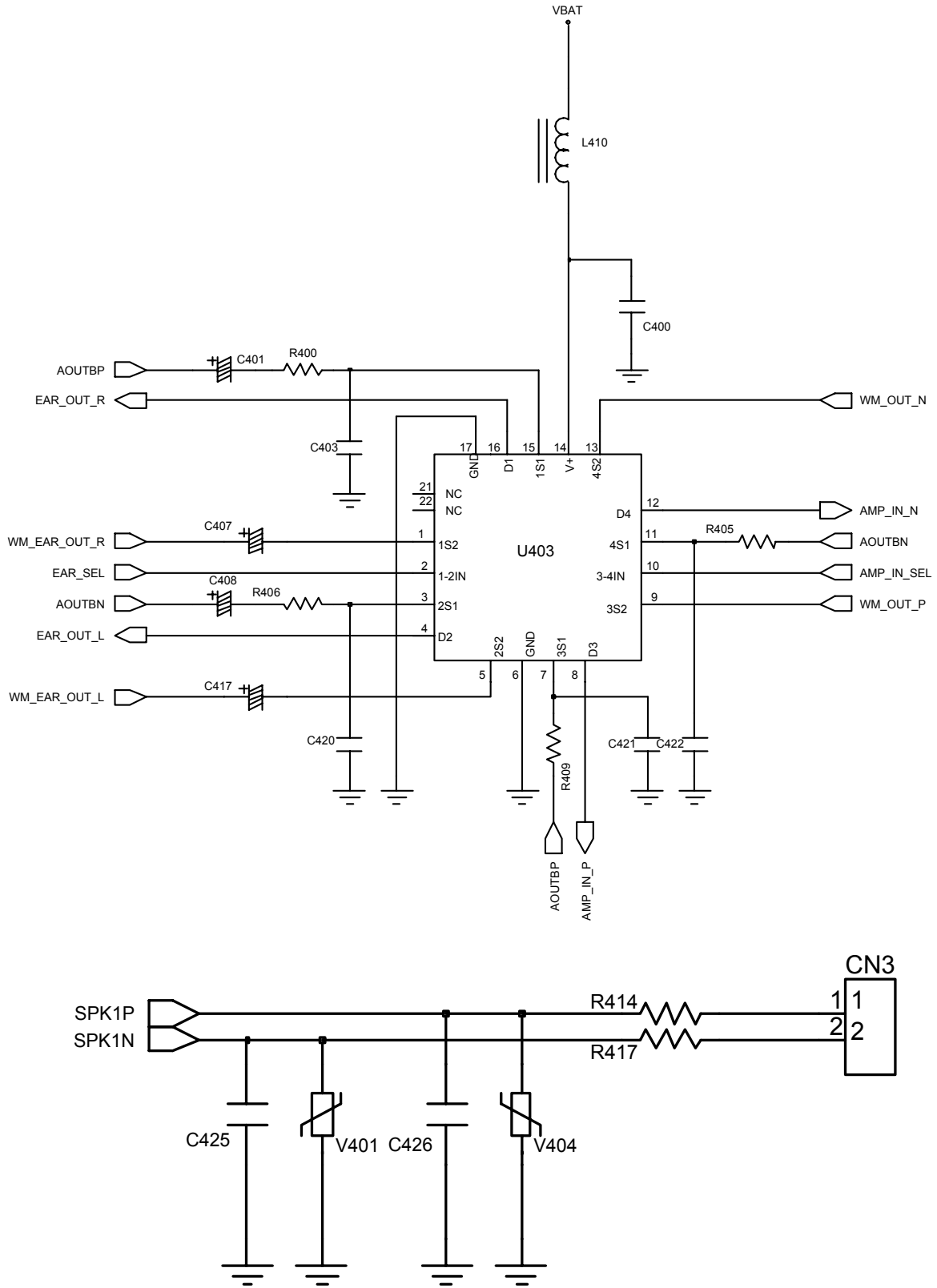

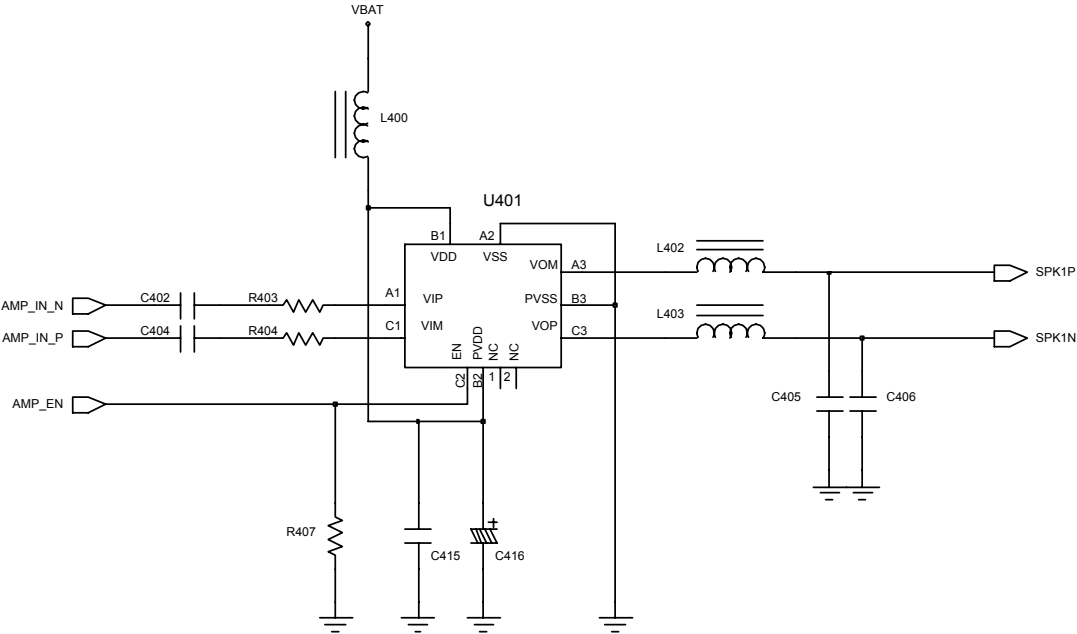
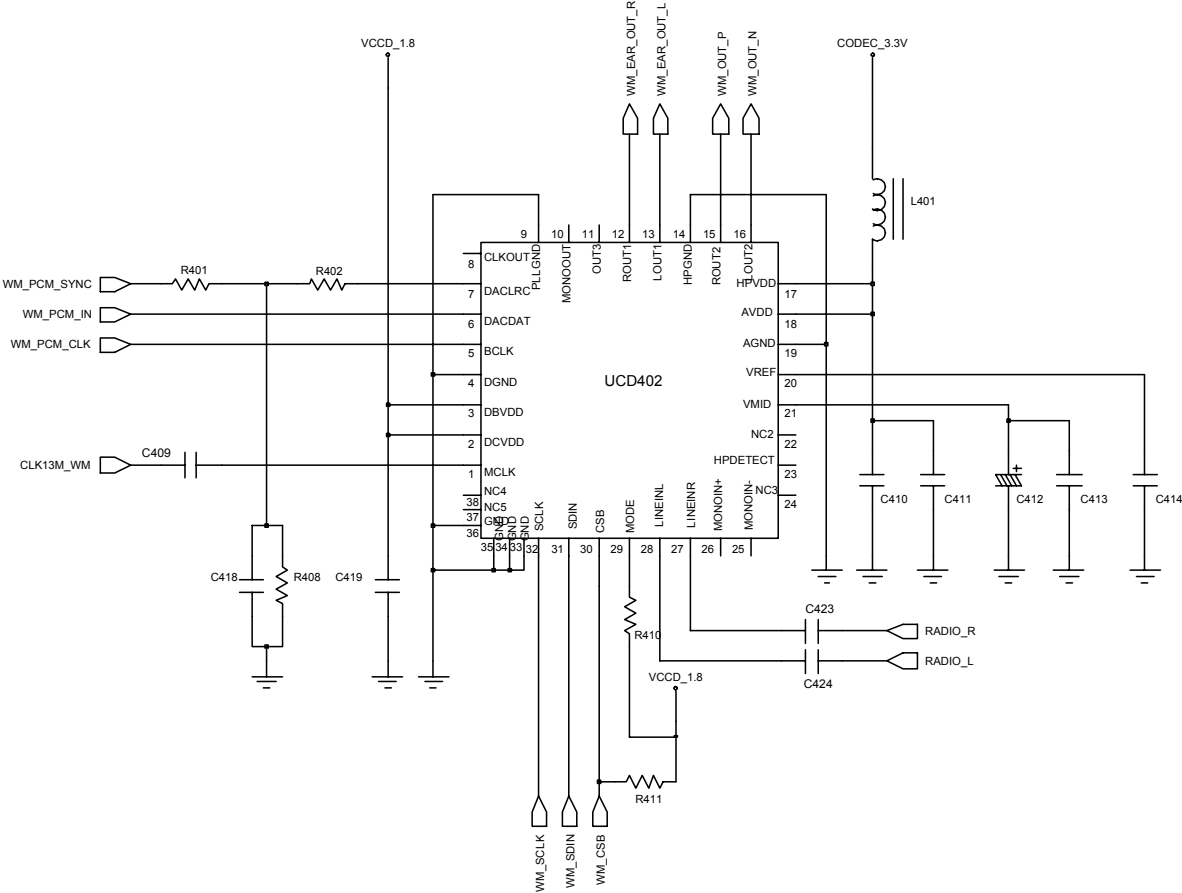

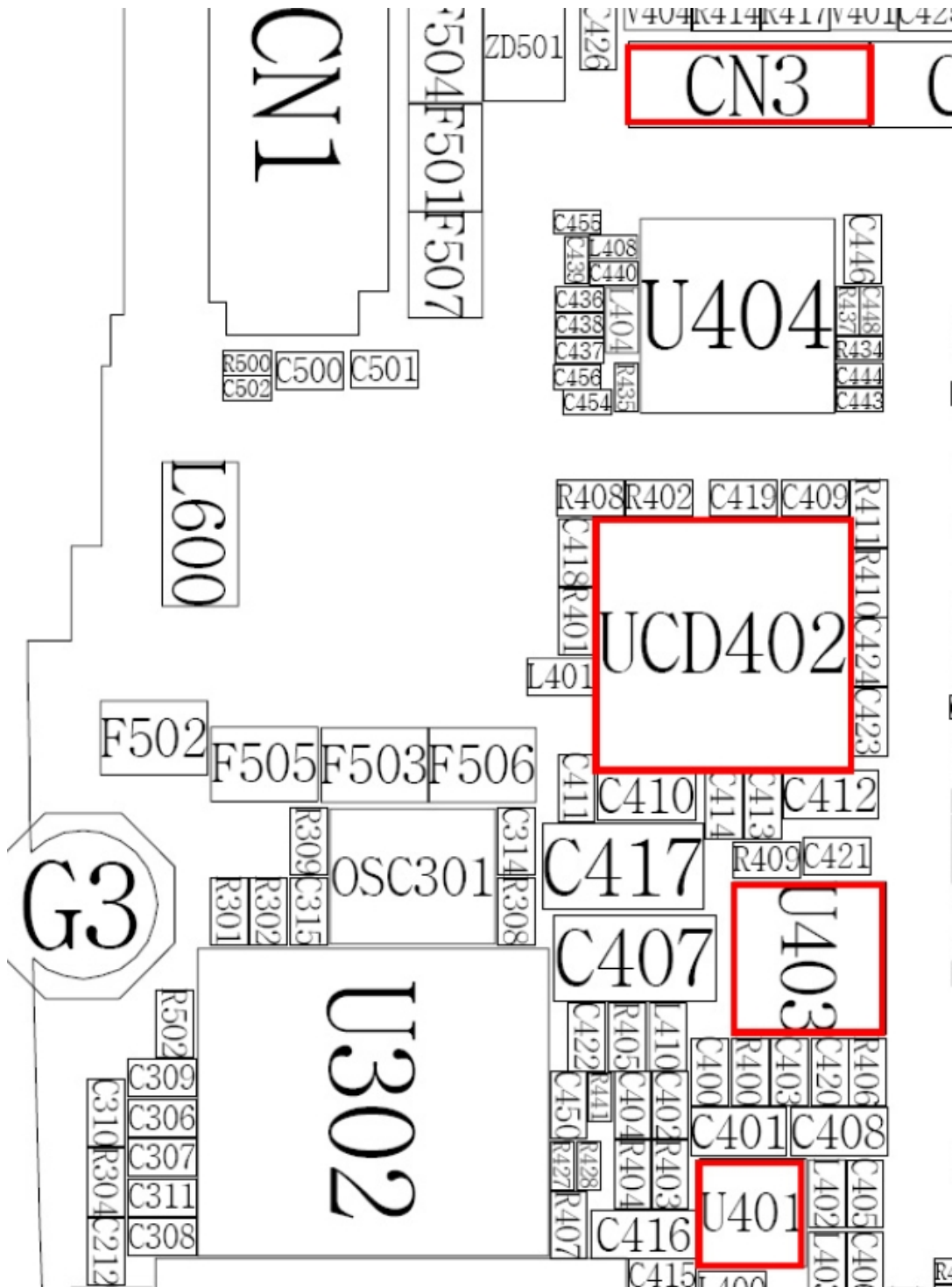

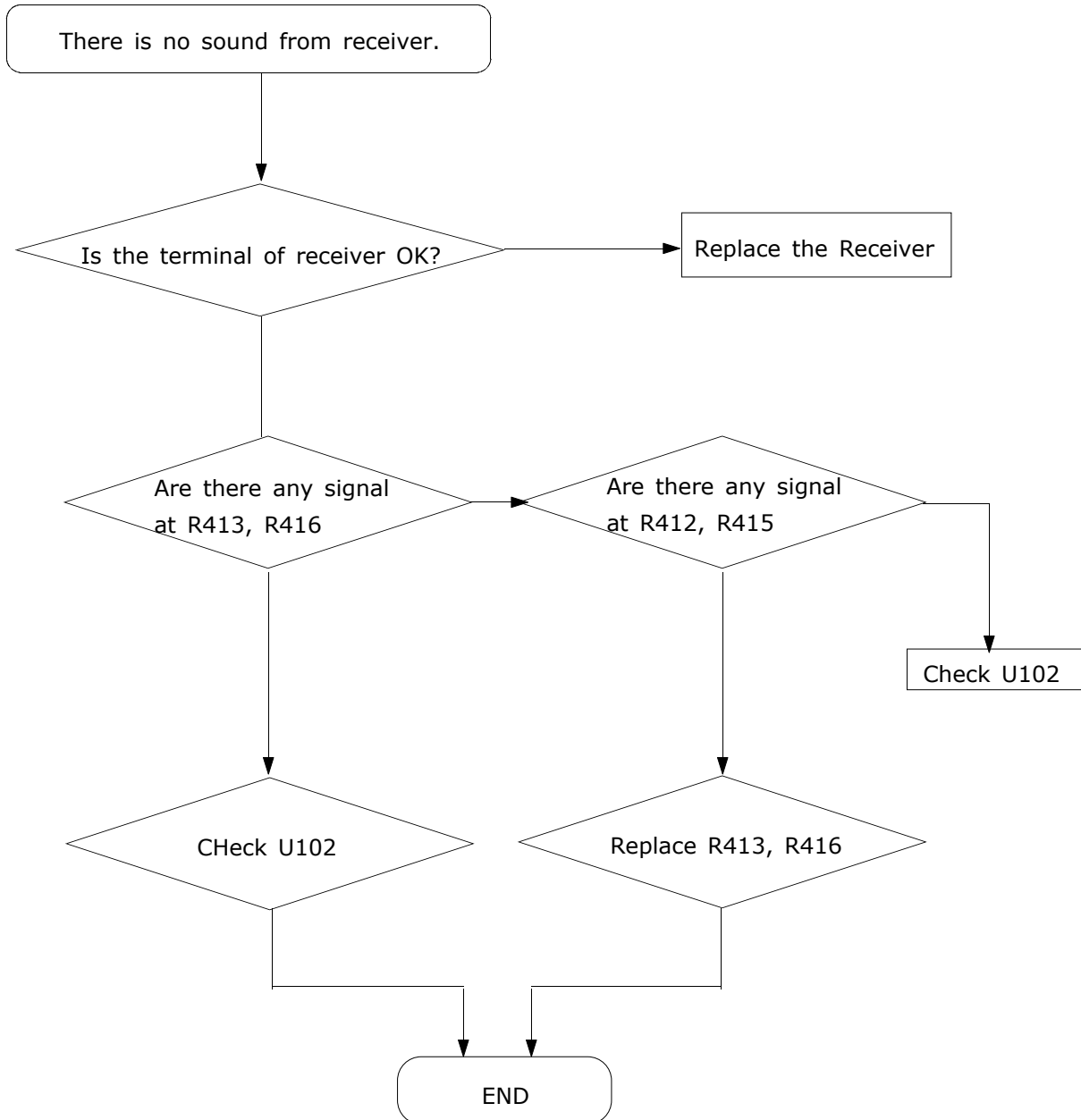
**10-1-7. Receiver Part**



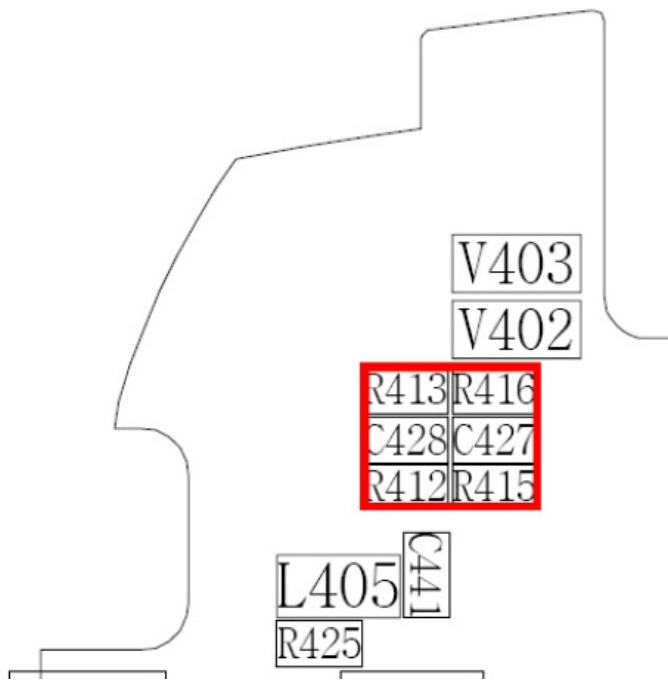
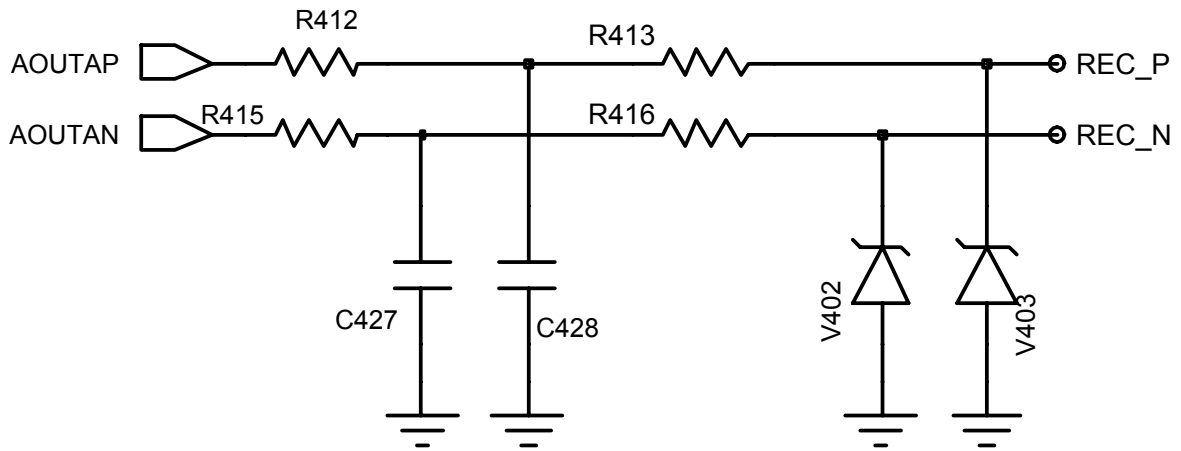

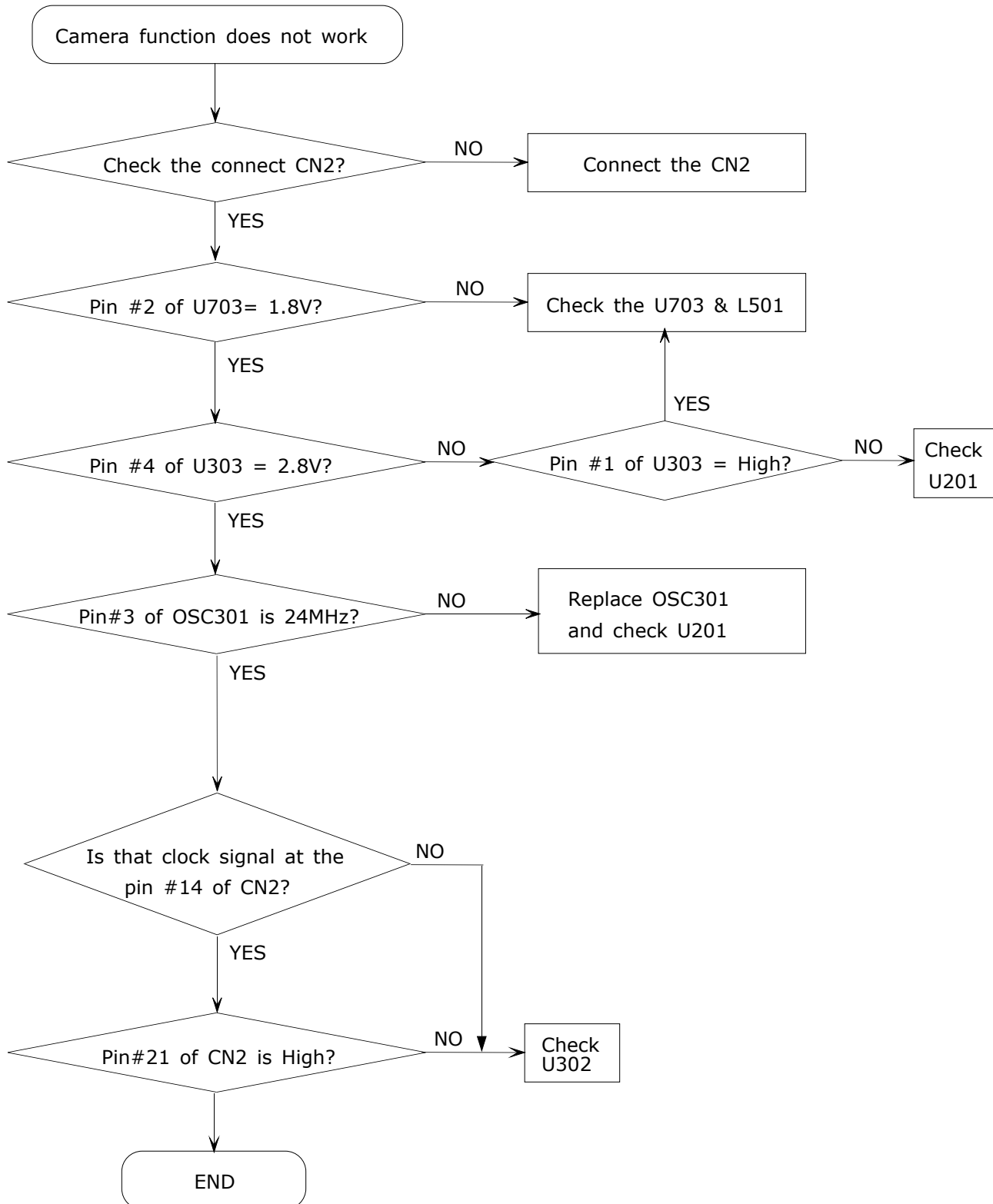
**10-1-8. Camera part**

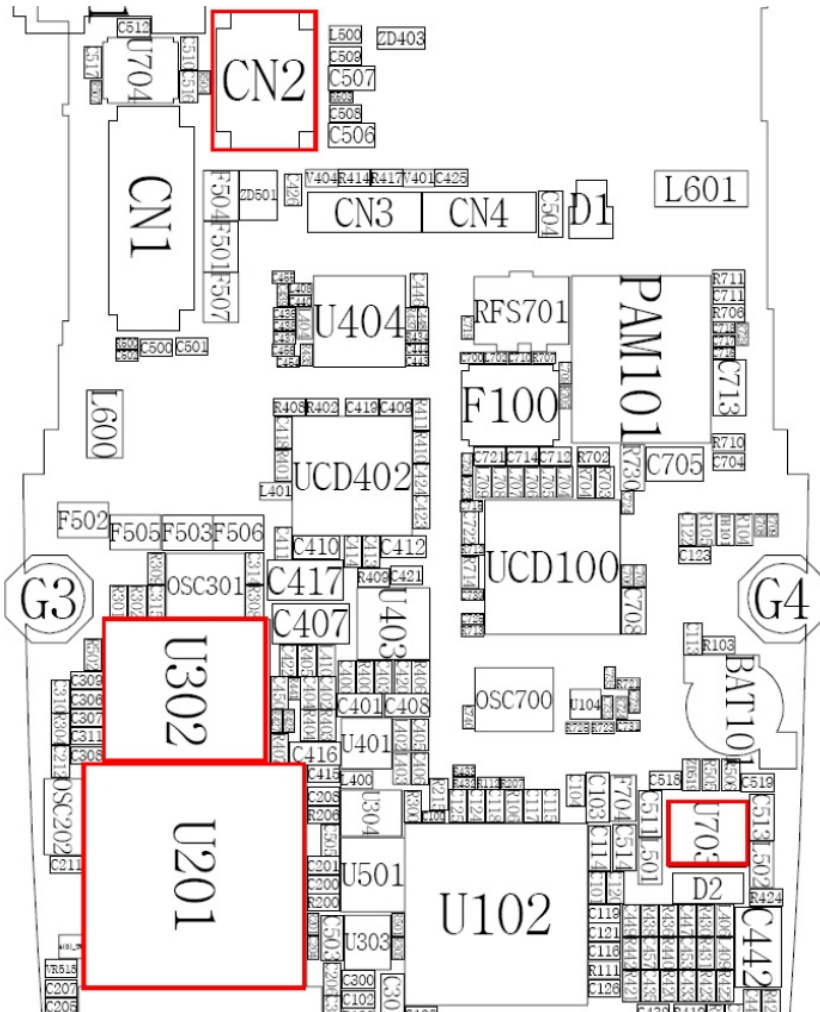
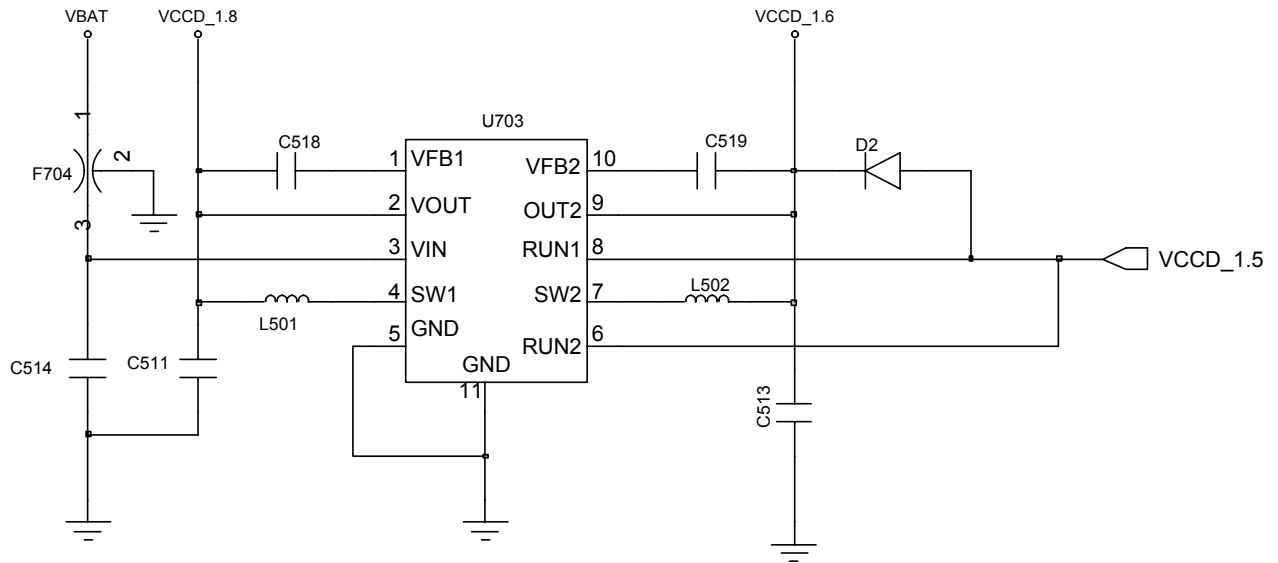

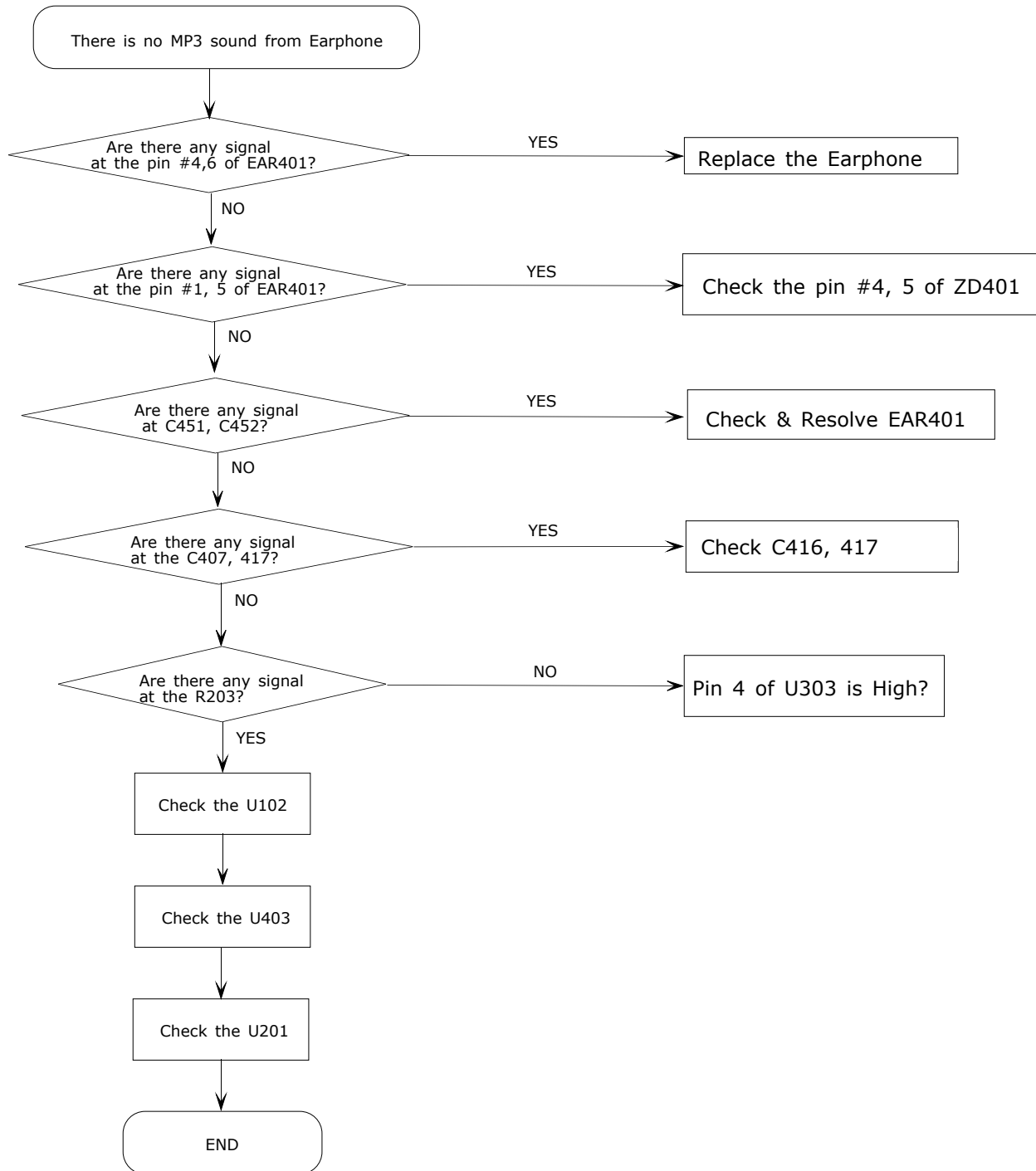
**10-1-9. Mp3 part**

# Flow Chart of Troubleshooting

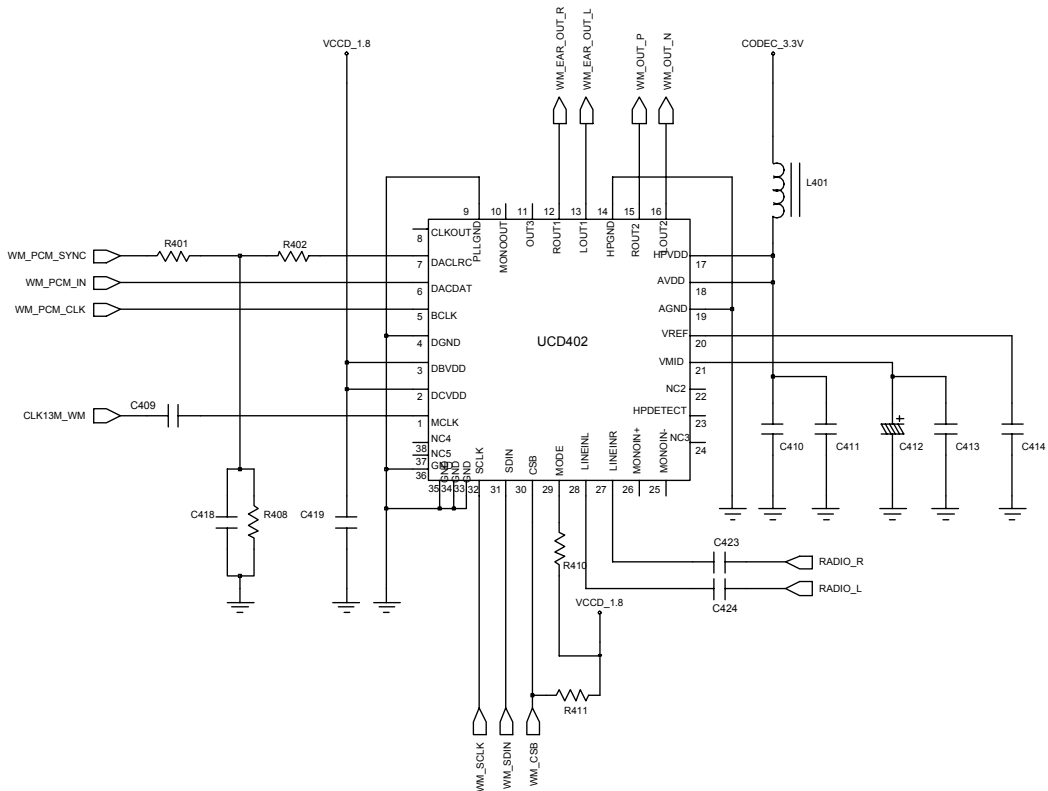
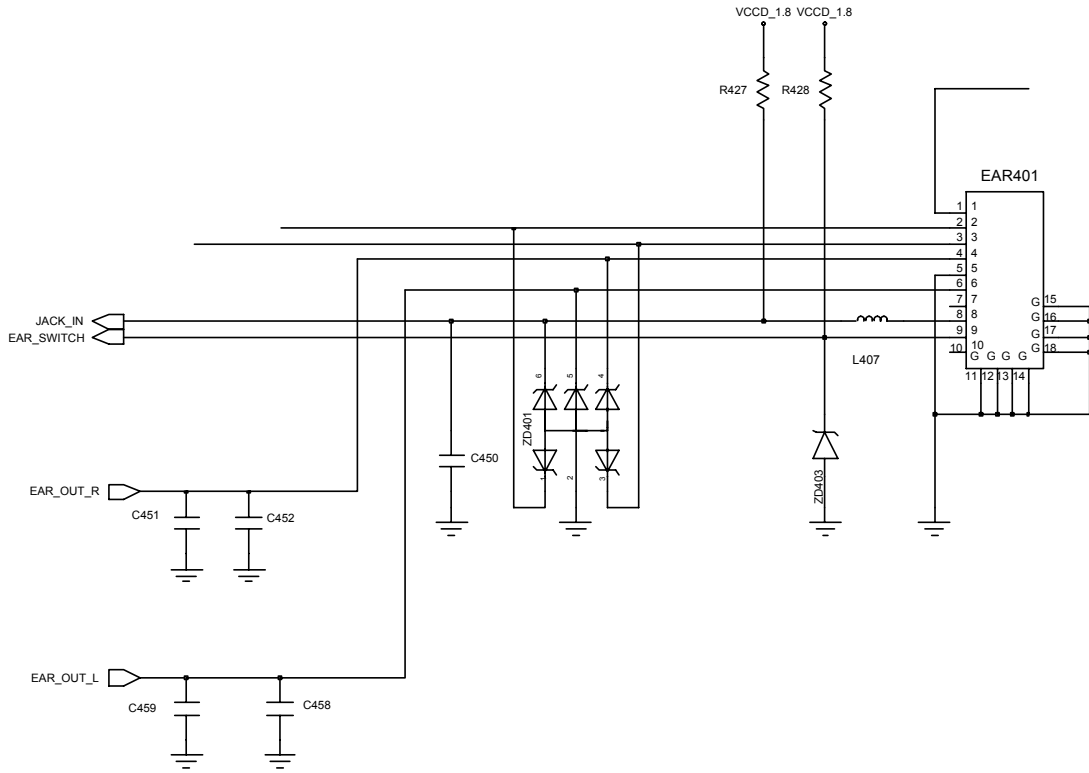

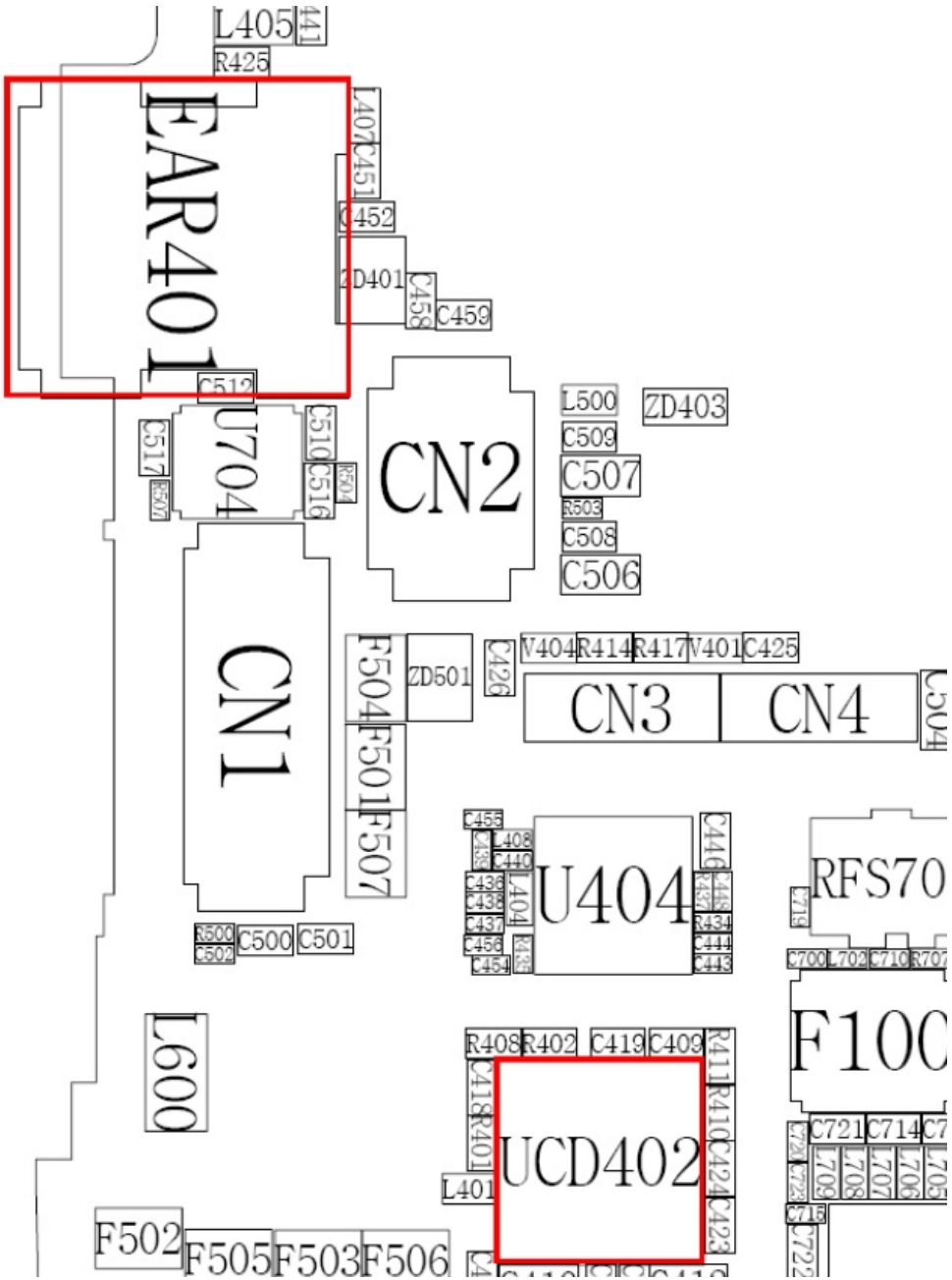

### 10-1-10. FM Radio part

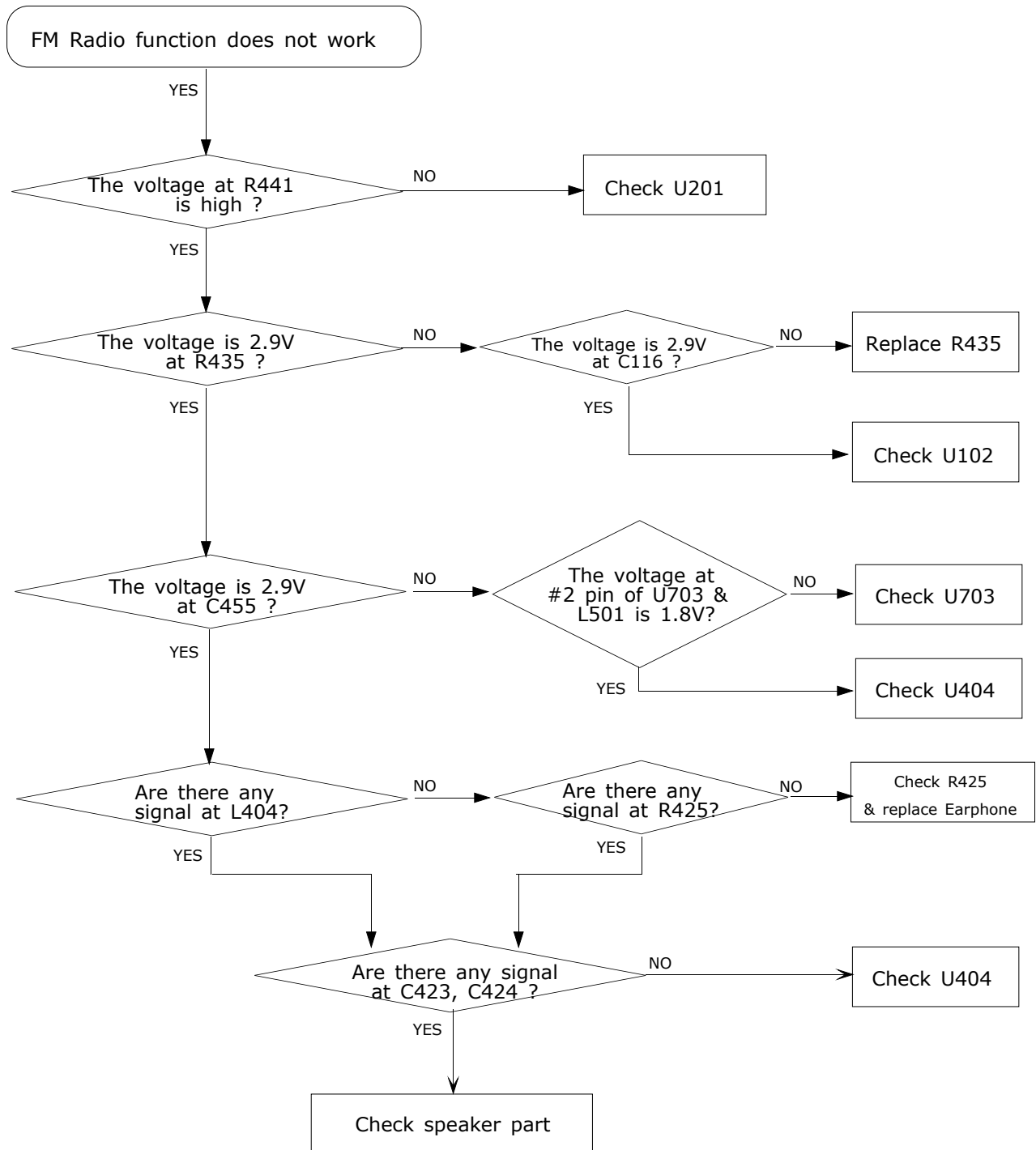





## 10-2. RF

### 10-2-1. EGSM RX

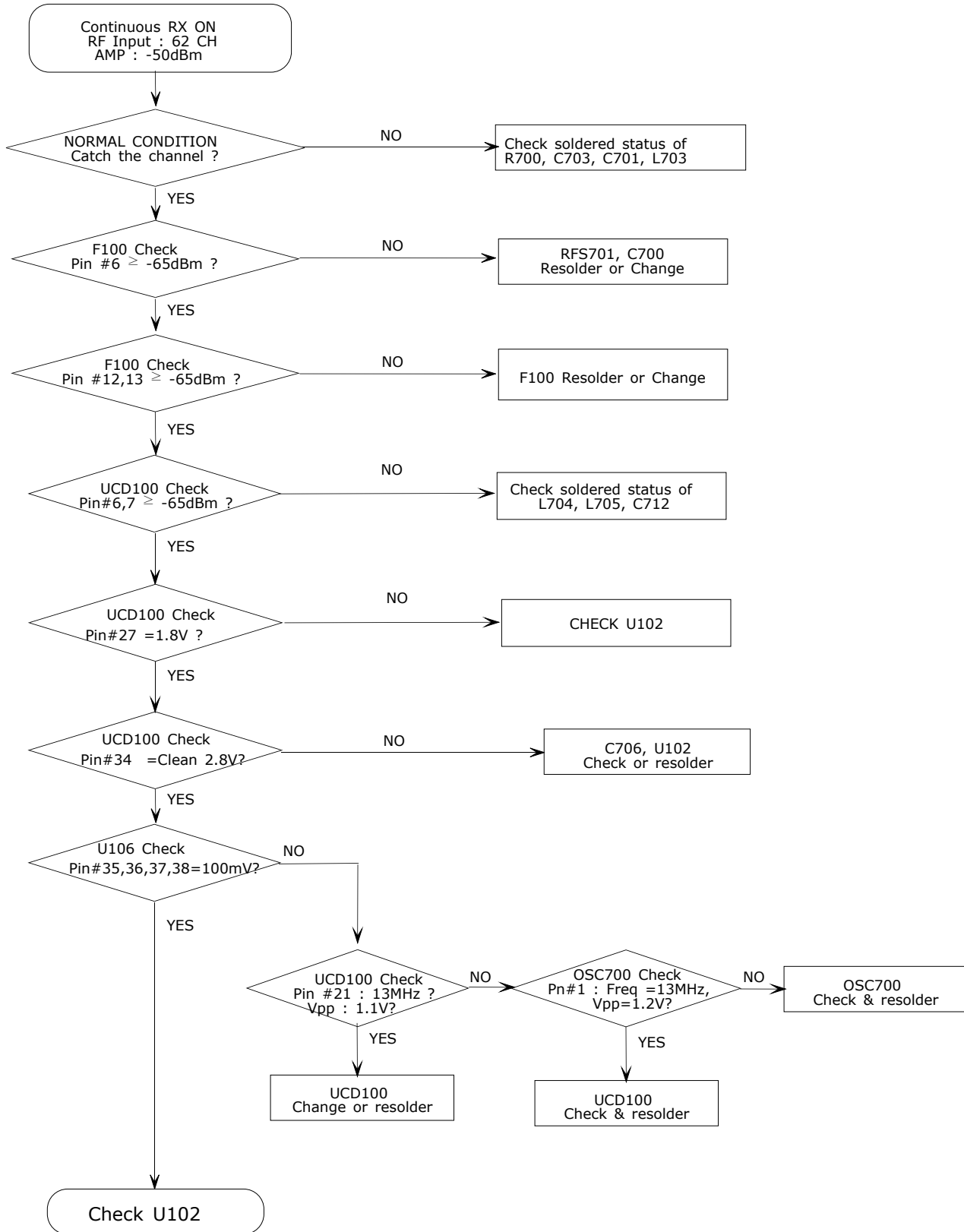

### 10-2-2. DCS RX

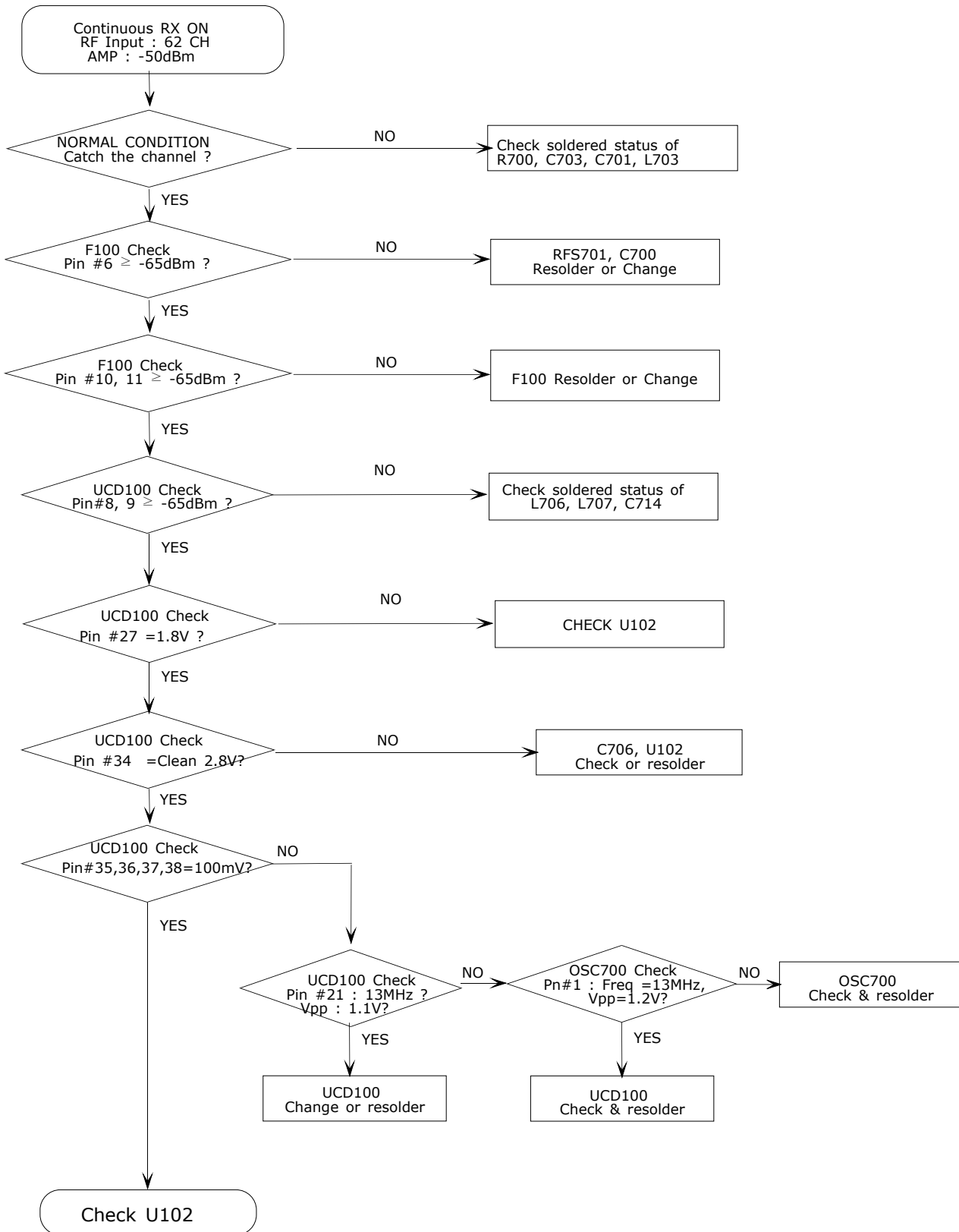

### 10-2-3. PCS RX

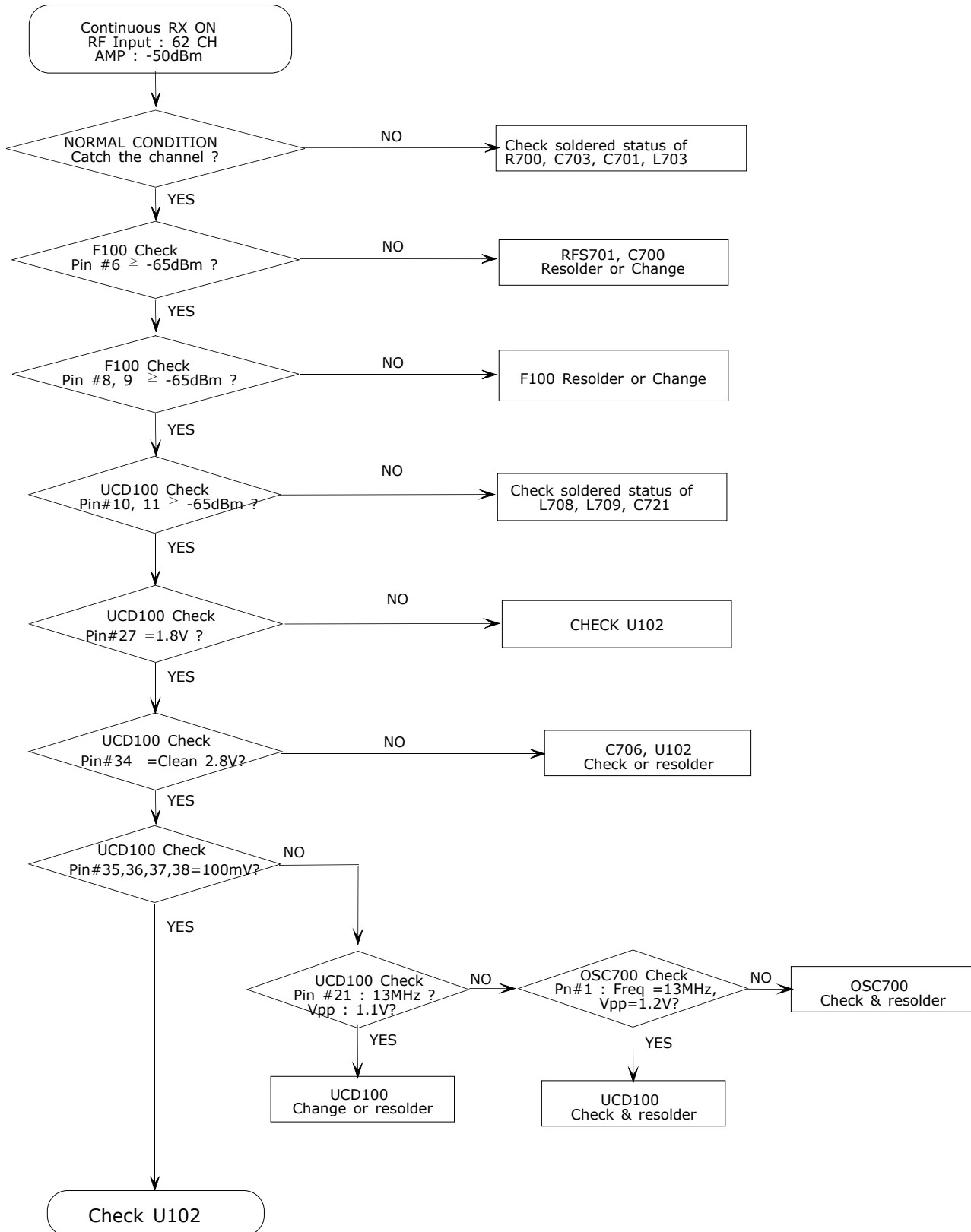

**10-2-4. EGSM TX**

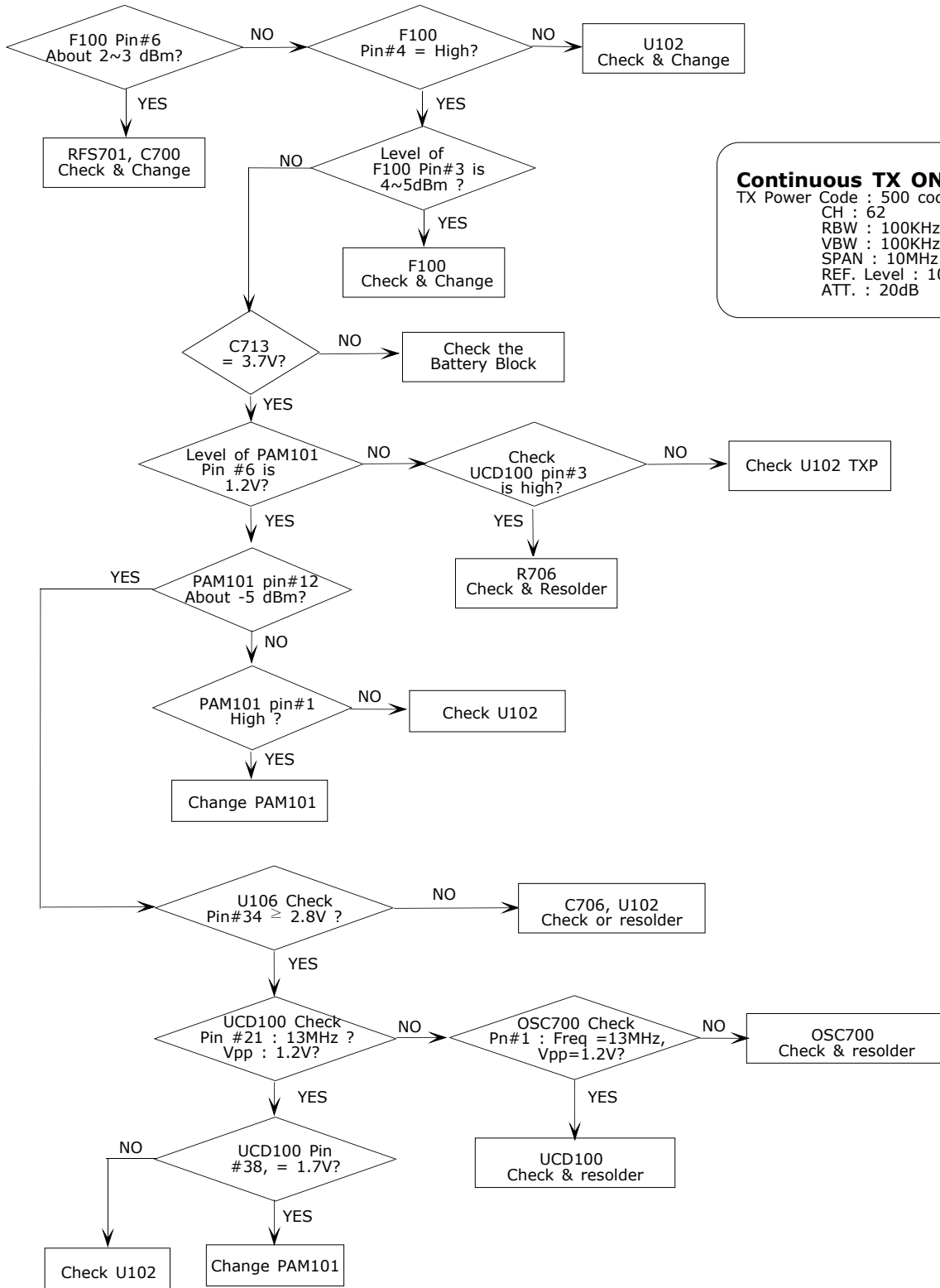

**Continuous TX ON condition**  
 TX Power Code : 500 code Applied  
 CH : 62  
 RBW : 100KHz  
 VBW : 100KHz  
 SPAN : 10MHz  
 REF. Level : 10dBm  
 ATT. : 20dB

**10-2-5. DCS & PCS TX**

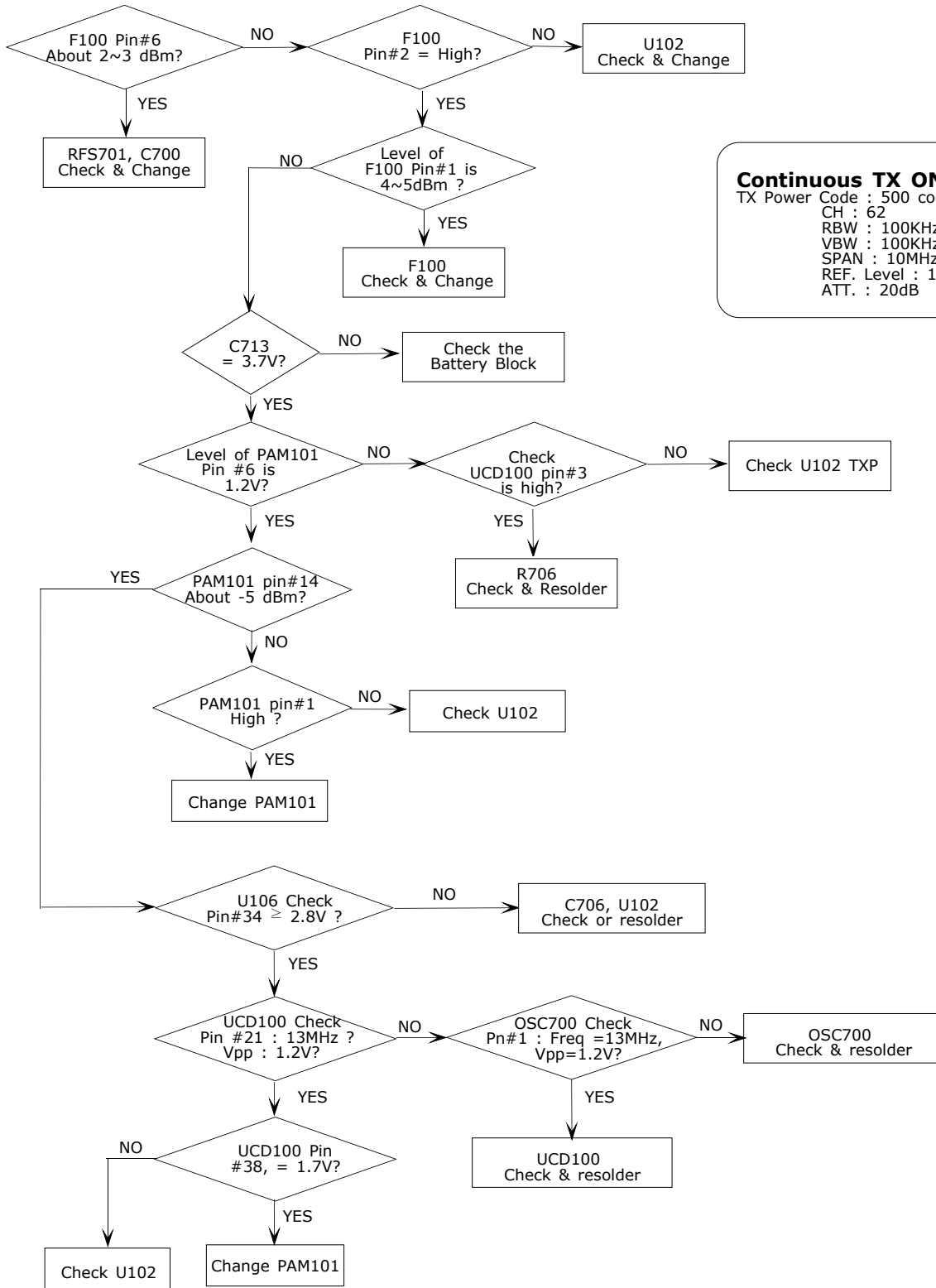

**Continuous TX ON condition**  
 TX Power Code : 500 code Applied  
 CH : 62  
 RBW : 100KHz  
 VBW : 100KHz  
 SPAN : 10MHz  
 REF. Level : 10dBm  
 ATT. : 20dB

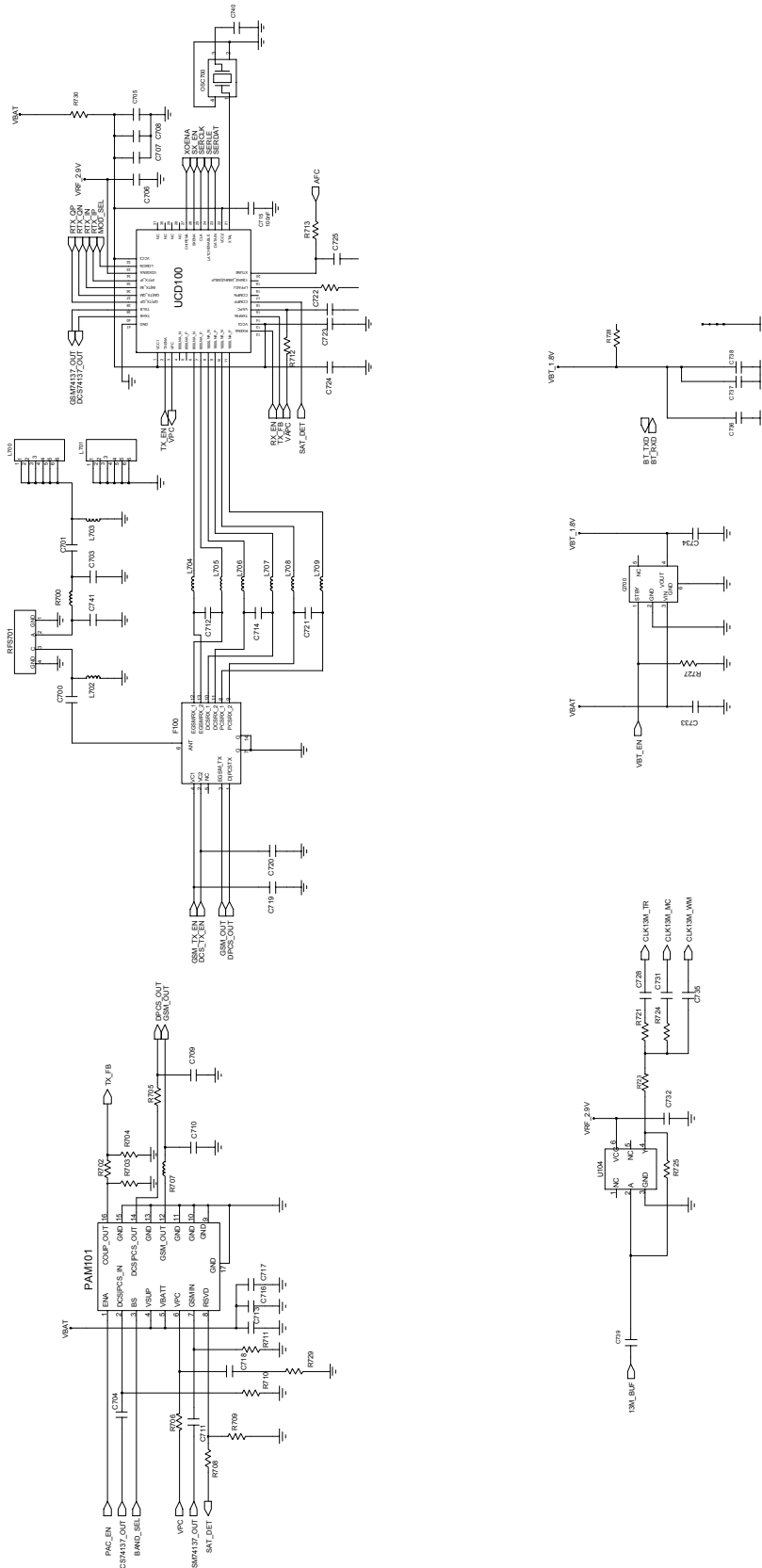

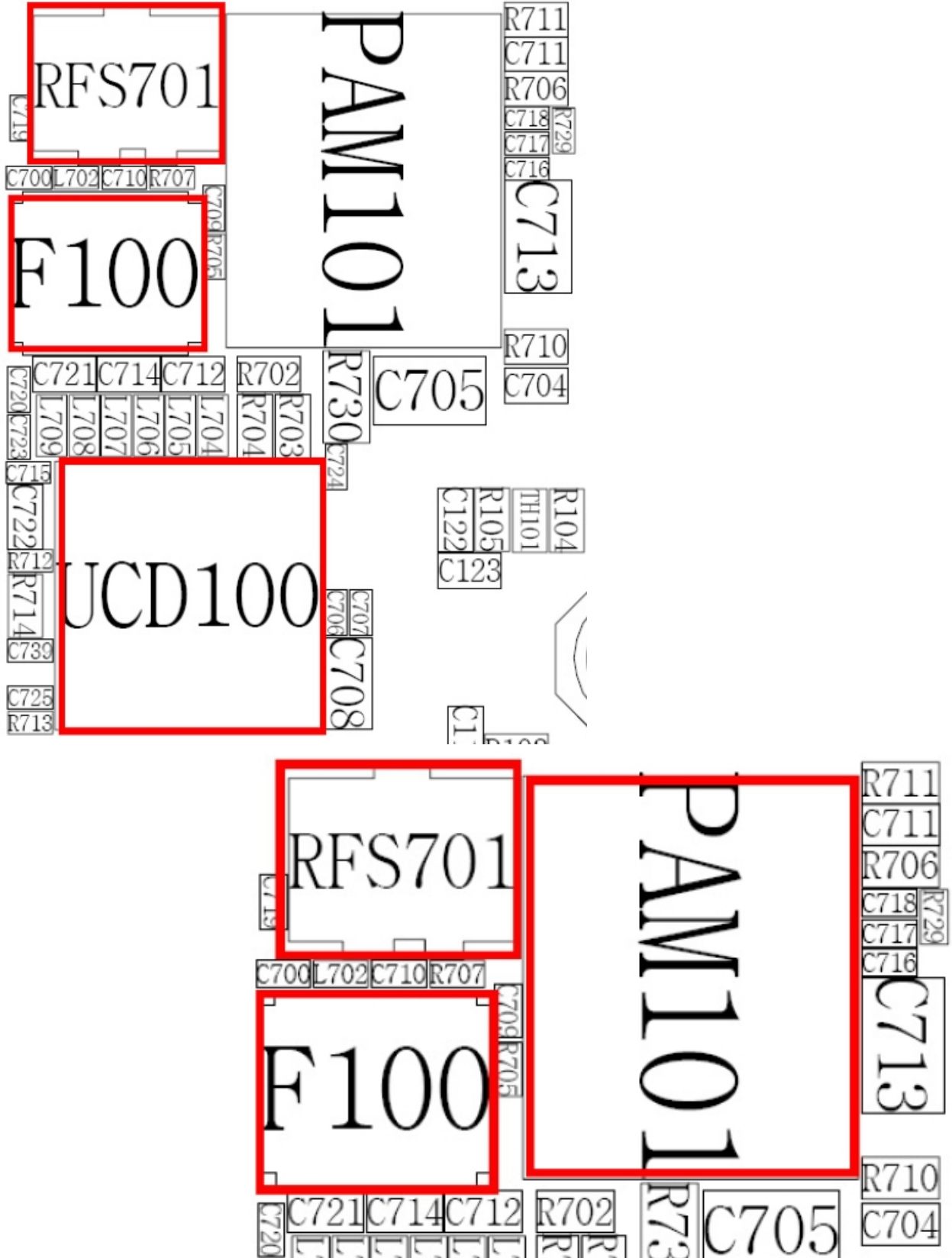

---

# 11. Reference data

---

## 11-1. Reference Abbreviate

**AAC**: Advanced Audio Coding.

**AVC** : Advanced Video Coding.

**BER** : Bit Error Rate

**BPSK**: Binary Phase Shift Keying

**CA** : Conditional Access

**CDM** : Code Division Multiplexing

**C/I** : Carrier to Interference

**DMB** : Digital Multimedia Broadcasting

**EN** : European Standard

**ES** : Elementary Stream

**ETSI**: European Telecommunications Standards Institute

**MPEG**: Moving Picture Experts Group

**PN** : Pseudo-random Noise

**PS** : Pilot Symbol

**QPSK**: Quadrature Phase Shift Keying

**RS** : Reed-Solomon

**SI** : Service Information

**TDM** : Time Division Multiplexing

**TS** : Transport Stream



**SAMSUNG  
ELECTRONICS**

