

SAMSUNG

GSM TELEPHONE

SGH-X500

SERVICE *Manual*

GSM TELEPHONE



CONTENTS

1. Safety Precautions
2. Specification
3. Product Function
4. Array course control
5. Exploded View and Parts List
6. Disassembly and Assembly instructions
7. MAIN Electrical Parts List
8. Block Diagrams
9. PCB Diagrams
10. Flow Chart of Troubleshooting
11. Reference data

Contents

1. Safety Precautions

- 1-1. Repair Precaution1-1
- 1-2. ESD(Electrostatically Sensitive Devices) Precaution1-2

2. Specification

- 2-1. GSM General Specification2-1
- 2-2. GSM Tx Power Class2-2

3. Product Function

- 3-1. Main Function3-1

4. Array course control

Software Downloading

- 4-1. Downloading Binary Files4-2
- 4-2. Pre-requisite for Downloading4-2
- 4-3. S/W Downloader Program4-3

5. Exploded View and Parts List

- 5-1. Cellular phone Exploded View5-1
- 5-2. Cellular phone Part list5-2

6. Disassembly and Assembly instructions

- 6-1. Disassembly6-1
- 6-2. Assembly6-3
- 6-3. LCD KIT6-6

7. MAIN Electrical Parts List

8. Block Diagrams

- 8-1. RF PART8-1
- 8-2. ROGIC PART8-2
- 8-3. BT Block8-3

9. PCB Diagrams

Contents

10. Flow Chart of Troubleshooting

10-1. Baseband

10-1-1. Power ON	10-1
10-1-2. Initial	10-4
10-1-3. Sim Part	10-6
10-1-4 Microphone Part	10-8
10-1-5. Speaker Part	10-10

10-2. RF

10-2-1. EGSM RX	10-13
10-2-2. DCS RX	10-14
10-2-3. PCS RX	10-15
10-2-4. EGSM TX	10-17
10-2-5. DCS/PCS TX	10-18

11. Reference data

1. Safety Precautions

1-1. Repair Precaution

- Repair in Shield Box, during detailed tuning.
Take specially care of tuning or test,
because specipicty of cellular phone is sensitive for surrounding interference(RF noise).
- Be careful to use a kind of magnetic object or tool,
because performance of parts is damaged by the influence of manetic force.
- Surely use a standard screwdriver when you disassemble this product,
otherwise screw will be worn away.
- Use a thicken twisted wire when you measure level.
A thicken twisted wire has low resistance, therefore error of measurement is few.
- Repair after separate Test Pack and Set because for short danger (for example an
overcurrent and furious flames of parts etc) when you repair board in condition of
connecting Test Pack and tuning on.
- Take specially care of soldering, because Land of PCB is small and weak in heat.
- Surely tune on/off while using AC power plug, because a repair of battery charger is
dangerous when tuning ON/OFF PBA and Connector after disassembling charger.
- Don't use as you pleases after change other material than replacement registered on SEC
System.
Otherwise engineer in charge isn't charged with problem that you don't keep this rules.

1-2. ESD(Electrostatically Sensitive Devices) Precaution

Several semiconductor may be damaged easily by static electricity. Such parts are called by ESD(Electrostatically Sensitive Devices), for example IC,BGA chip etc. Read Precaution below. You can prevent from ESD damage by static electricity.

- Remove static electricity remained your body before you touch semiconductor or parts with semiconductor. There are ways that you touch an earthed place or wear static electricity prevention string on wrist.
- Use earthed soldering steel when you connect or disconnect ESD.
- Use soldering removing tool to break static electricity. , otherwise ESD will be damaged by static electricity.
- Don't unpack until you set up ESD on product. Because most of ESD are packed by box and aluminum plate to have conductive power,they are prevented from static electricity.
- You must maintain electric contact between ESD and place due to be set up until ESD is connected completely to the proper place or a circuit board.

2. Specification

2-1. GSM General Specification

	GSM900 Phase 1	EGSM 900 Phase 2	DCS1800 Phase 1	PCS1900
Freq. Band[MHz] Uplink/Downlink	890~915 935~960	880~915 925~960	1710~1785 1805~1880	1850~1910 1930~1990
ARFCN range	1~124	0~124 & 975~1023	512~885	512~810
Tx/Rx spacing	45 MHz	45 MHz	95 MHz	80 MHz
Mod. Bit rate/ Bit Period	270.833 kbps 3.692 us	270.833 kbps 3.692 us	270.833 kbps 3.692 us	270.833 kbps 3.692 us
Time Slot Period/Frame Period	576.9 us 4.615 ms	576.9 us 4.615 ms	576.9 us 4.615 ms	576.9 us 4.615 ms
Modulation	0.3 GMSK	0.3 GMSK	0.3 GMSK	0.3 GMSK
MS Power	33 dBm~5 dBm	33 dBm~5 dBm	30 dBm~0 dBm	30 dBm~0 dBm
Power Class	5 pcl ~ 19 pcl	5 pcl ~ 19 pcl	0 pcl ~ 15 pcl	0 pcl ~ 15 pcl
Sensitivity	-102 dBm	-102 dBm	-100 dBm	-100 dBm
TDMA Mux	8	8	8	8
Cell Radius	35 Km	35 Km	2 Km	-

2-2. GSM TX power class

TX Power control level	GSM900	TX Power control level	DCS1800	TX Power control level	PCS1900
5	33±2 dBm	0	30±3 dBm	0	30±3 dBm
6	31±2 dBm	1	28±3 dBm	1	28±3 dBm
7	29±2 dBm	2	26±3 dBm	2	26±3 dBm
8	27±2 dBm	3	24±3 dBm	3	24±3 dBm
9	25±2 dBm	4	22±3 dBm	4	22±3 dBm
10	23±2 dBm	5	20±3 dBm	5	20±3 dBm
11	21±2 dBm	6	18±3 dBm	6	18±3 dBm
12	19±2 dBm	7	16±3 dBm	7	16±3 dBm
13	17±2 dBm	8	14±3 dBm	8	14±3 dBm
14	15±2 dBm	9	12±4 dBm	9	12±4 dBm
15	13±2 dBm	10	10±4 dBm	10	10±4 dBm
16	11±3 dBm	11	8±4 dBm	11	8±4 dBm
17	9± 3dBm	12	6±4 dBm	12	6±4 dBm
18	7±3 dBm	13	4±4 dBm	13	4±4 dBm
19	5±3 dBm	14	2±5 dBm	14	2±5 dBm
		15	0±5 dBm	15	0±5 dBm

3. Product Function

Main Function

- My mane card
- Java world
- Voice memo
- Stopwatch
- SIM service
- Access the homepage
- SMS and MMS
- Bluetooth
- Set Quiet mode
- Network services

4. Array course control

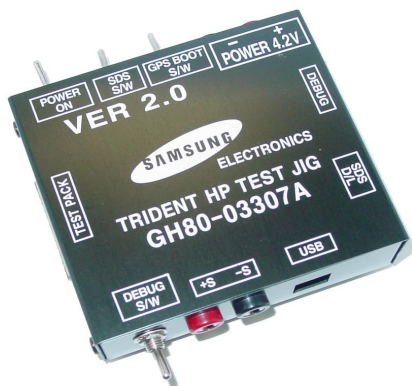

Test Jig (GH80-03307A)



Test Cable (GH39-00127A)



RF Test Cable (GH39-00397A)

Software Downloading

4-1. Downloading Binary Files

- Three binary files for downloading X500 .
 - X500XXYY.s3 : Main source code binary.

4-2. Pre-requisite for Downloading

- Downloader Program([OptiFlash.exe](#))
- X500 Mobile Phone
- Data Cable
- Binary files

4-3. S/W Downloader Program

1. Load the binary download program by executing the "**OptiFlash.exe**"

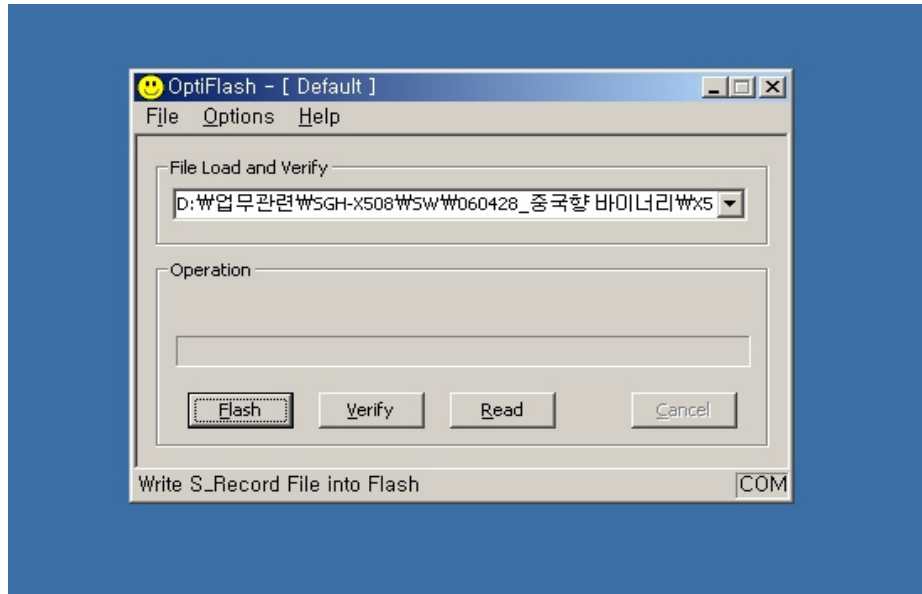

2. Select the "**Options**" -> "**Settings**" -> "**Generic**" -> "**Specify hardware platform**".

Choose hardware platform for the downloader file setting.♪

Set the everything else as the default values which are shown below

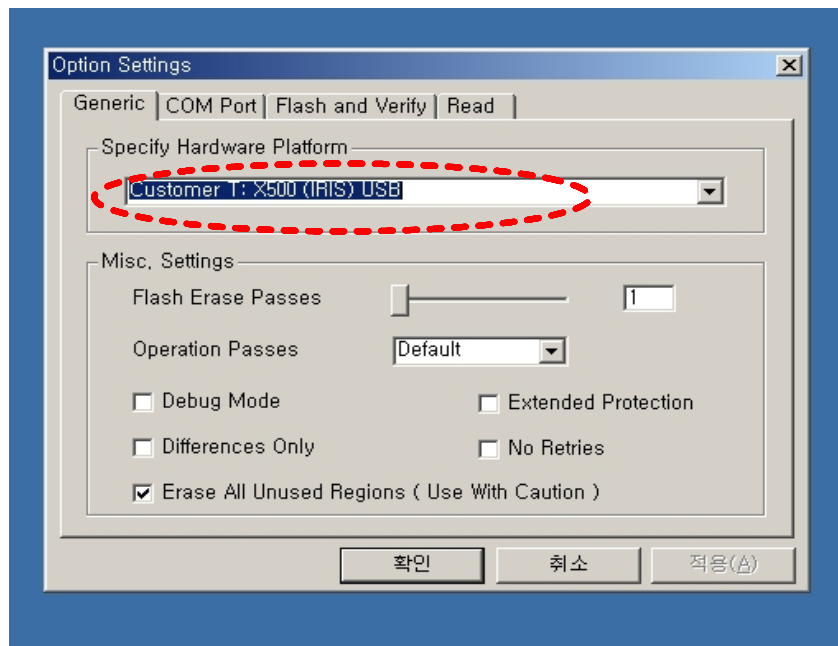

3. Select the **COM port** when the download cable is connected

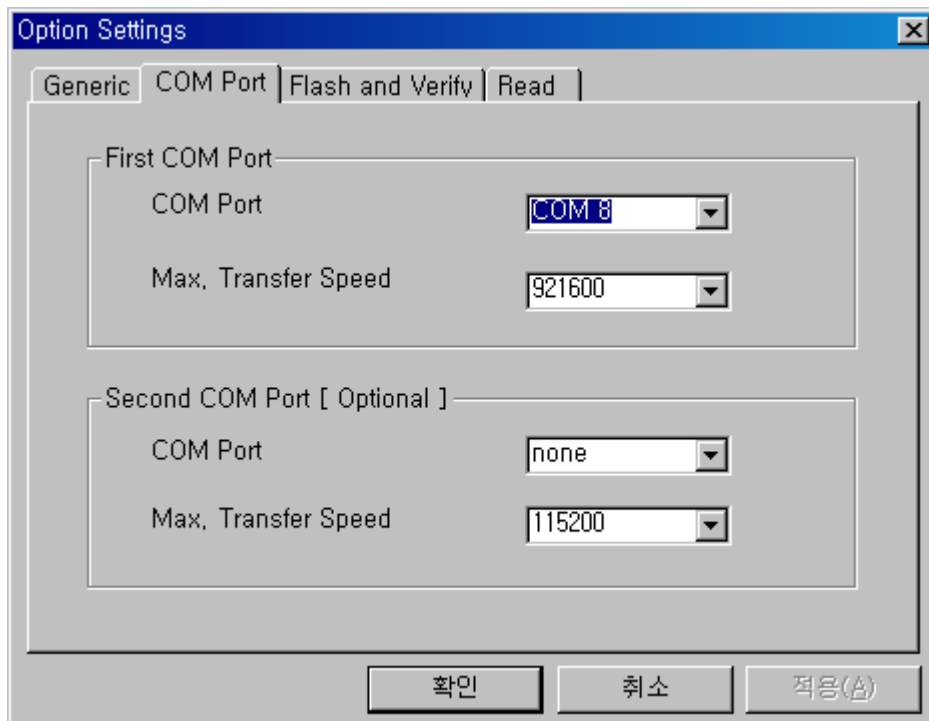

Up to twelve ports are supported. Additionally you can select the maximum transfer speed OptiFlash will use to communicate with the phone. However, OptiFlash will use a slower speed if either the PC's or the phone's serial hardware is incapable of handling the selected speed

4. Select the "Flash&Verify" -> "Browse"

Set the directory path and choose the latest s/w binary, for example "X500XXYY.s3", for the downloader binary setting.

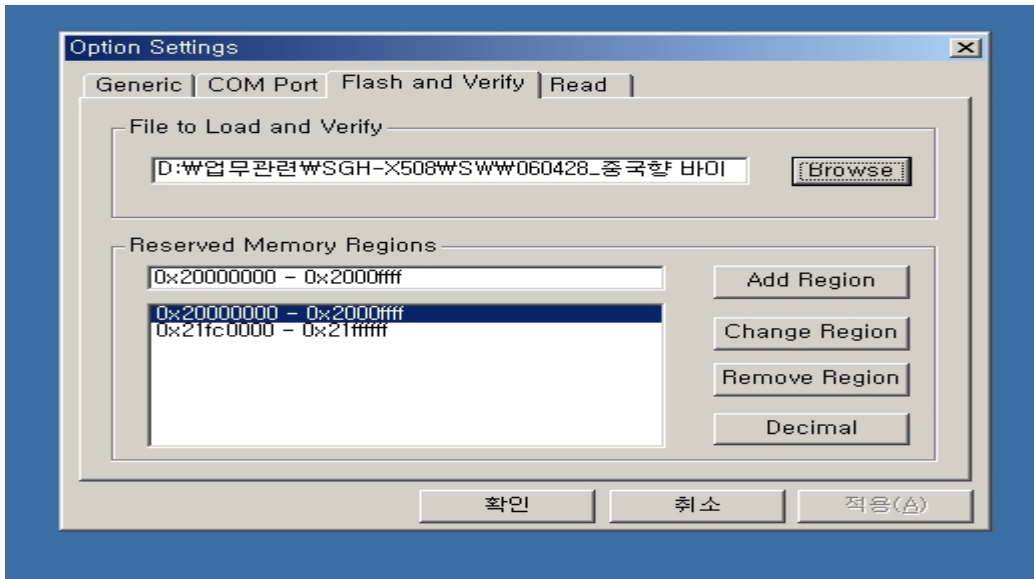

Make sure that not to change the reserved memory regions.

In case of X500 the reserved regions are :

-0x20000000 - 0x2000ffff

-0x21fc0000- 0x21ffffff

5. Click "OK" button then press "Flash".
(Before pressing 'Flash' button, push the button '* and 'END' at the same time. Then press 'Flash'.)

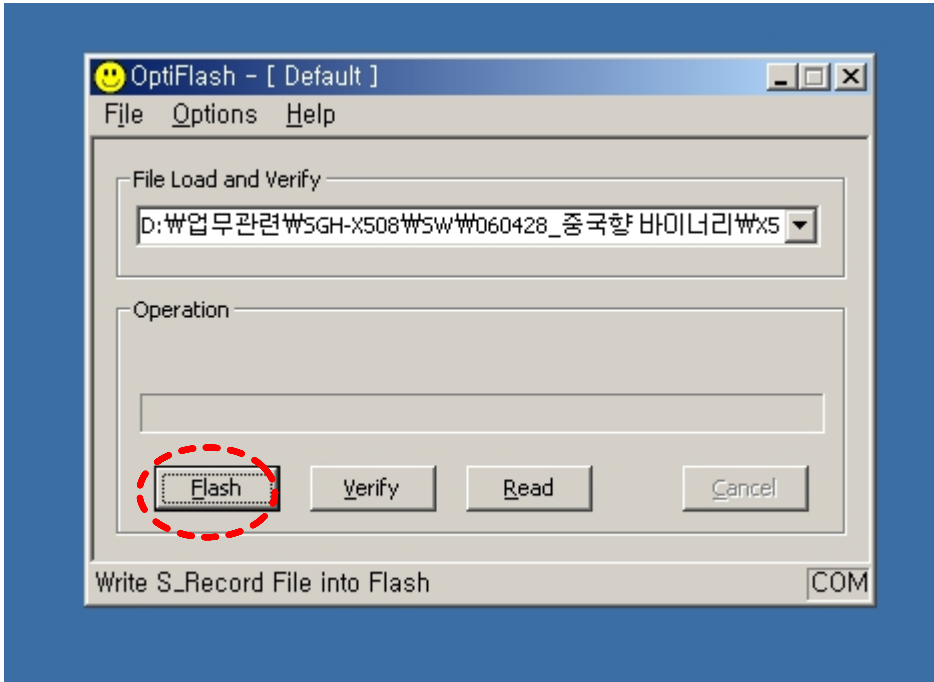

Downloader will upload the binary file as below for the downloading.

6. When downloading is finished successfully, there is a "All is well" message.

7. After finishing downloading, Certain memory resets should be done to guarantee the normal performance.

8. Confirm the downloaded version name and etc. :

***#1234#**

Full Reset :

***2767*3855#**

5. Exploded View and Parts List

5-1. Cellular phone Exploded View

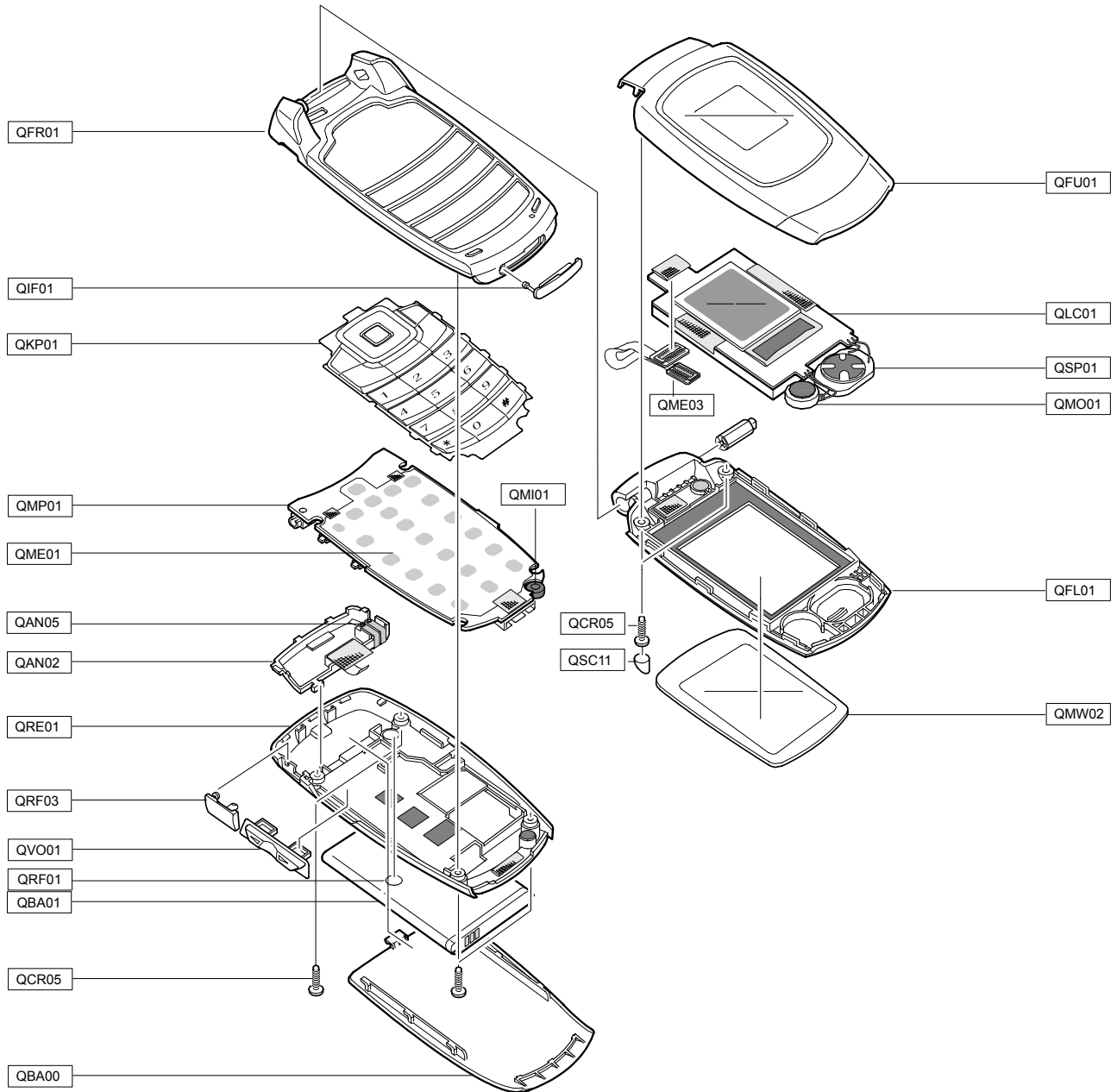

5-2. Cellular phone Parts list

Design LOC		Discription	SEC CODE
QAN02		INTENNA-SGHX500	GH42-00829A
QAN05		ASSY MEC-INTENNA CONTACT	GH75-08168A
QBA00		PMO-COVER BATT	GH72-30639A
QBA01		INNER BATTERY PACK-750MAH,BLK,	GH43-02483A
QCR05		SCREW-MACHINE	6001-001478
QCR05		SCREW-MACHINE	6001-001478
QFL01		ASSY-CASE-LOWER	GH98-00893A
QFU01		ASSY-CASE-UPPER	GH98-00894A
QKP01		ASSY-KEY-KEYPAD(XEF/CDA)	GH98-00896A
QLC01		MEA-LCD MODULE KIT	GH97-06021A
QME01		UNIT-METAL DOME	GH59-03100A
QME03		UNIT-CON TO CON	GH59-03148A
QMI01		MICROPHONE-ASSY-6.25MM	GH30-00177F
QMO01		MOTOR DC-SGHZ130	GH31-00154C
QMP01		PBA MAIN-SGHX500	GH92-02716A
QMW02		PMO-COVER MAIN WINDOW	GH72-30637A
QRF01		MPR-TAPE RF	GH74-22888A
QSC11		RMO-COVER FOLDER SCREW	GH73-06994A
QSP01		SPEAKER	3001-001963
QVO01		ASSY KEY-VOLUME	GH98-01510A
QFR01		ASSY-CASE-FRONT	GH98-00892A
	QIF01	PMO-COVER IF	GH72-30580A
QRE01		ASSY-CASE-REAR	GH98-00895A
	QRF03	PMO-COVER EARJACK	GH72-30586A

Discription	SEC CODE
CARD-WARRANTY	6801-001501
BAG PE	6902-000297
ADAPTOR-SGHN288 TAD	GH44-00184A
LABEL(P)-IMEI	GH68-01335D
LABEL(P)-WATER SOAK	GH68-02026A
LABEL(P)-WATER SOAK	GH68-02026A
MANUAL USERS-EU FRENCH	GH68-09788A
LABEL(R)-MAIN(EU)	GH68-10707A
CUSHION-CASE TA2 220V	GH69-03307A
BOX(P)-UNIT MAIN(EU)	GH69-03892A
MPR-BOHO VINYL LCD CONN	GH74-15350A
MPR-TAPE PCB INSULATION2	GH74-17633A
MPR-TAPE LCD FPCB	GH74-22887A
MPR-TAPE LCD GASKET A	GH74-23216A
MPR-TAPE LCD A	GH74-23220A
MPR-TAPE LCD C	GH74-23222A
MPR-TAPE PBA A	GH74-23223A
MPR-TAPE PBA B	GH74-23224A
MPR-TAPE PBA C	GH74-23225A
MPR-VINYL BOHO MAIN WINDOW	GH74-23229A
MPR-TAPE LCD CONN	GH74-23517A
MPR-VINYL BOHO WINDOW PRESS	GH74-23519A
MPR-TAPE INTENNA GASKET	GH74-23811A
MPR-TAPE LCD SIDE	GH74-23812A
MPR-TAPE INTENNA REAR	GH74-23813A
MPR-TAPE PBA D	GH74-24143A
MPR-CUSHION LCD	GH74-24319A
MPR-CUSHION INTENNA	GH74-24320A
MPR-TAPE IF COVER	GH74-24740A
MPR-VINYL BOHO SUB WINDOW B	GH74-24835A
MPR-TAPE REAR BOSS	GH74-25692A

6. Disassembly and Assembly instructions



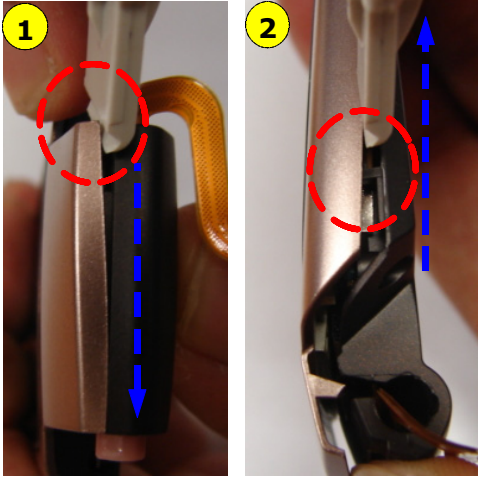
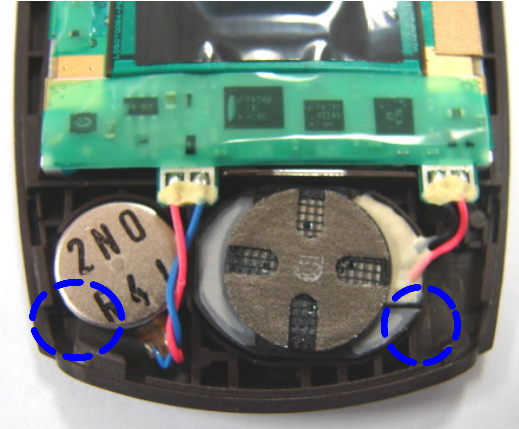

6-1. Disassembly

<p>1</p> 	<p>2</p> 
<p>1) Unscrew 4 point screw. 2) Extract EAR COVER. * caution 1) Be careful about the scratch occurrence or Framework deage.</p>	<p>1) Dissolve Hook Part with dissolving stick. 2) Dissolve from IF CONNECTOR. * caution 1) Be careful about the scratch occurrence or Framework damage. 2) Be careful about bending of REAR, so please insert finger to REAR inside.</p>
<p>3</p> 	<p>4</p> 
<p>1) Remove LCD CONNECTOR 2) Remove side VOLUME KEY 3) Disassemble MAIN PBA from FRONT ASS'Y 4) Remove FRONT strange material protecting tape with pincette. 5) Remove KEYPAD. * caution 1) Be careful a damage of PBA components. 2) Be careful about the tear of LCD FPCB molding damage!</p>	<p>1) Push FOLDER HINGE , separate FOLDER ASS'Y from FRONT * caution 1) Be careful about the scratch occurrence or Framework damage. 2) Be careful about the tear of LCD FPCB</p>

<p>5</p> 	<p>6</p> 
<p>1) Remove SCREW CAP from FOLDER ASS'Y 2) Remove SCREW form FOLDER ASS'Y * caution 1) Be careful about the scratch occurrence or Framework damage. 2) Be careful about the tear of LCD FPCB</p>	<p>1) Dissolve FOLDER HOOK using dissolving stick, please follow arrow direction. 2) Dissolve FOLDER SIDE HOOK using dissolving stick. * caution 1) Be careful about the scratch occurrence or Framework damage.</p>
<p>7</p> 	<p>8</p>
<p>1) Using pincette , Seperate MOTOR from FOLDER LOWER 2) Using pincette , Seperate SPEAKER from FOLDER LOWER * caution 1) Be careful about the scratch occurrence or Framework damage. 2) When you dissolve Motor and Speaker, you have to use pincette in the Hook(above blue Circle).</p>	

6-2. Assembly

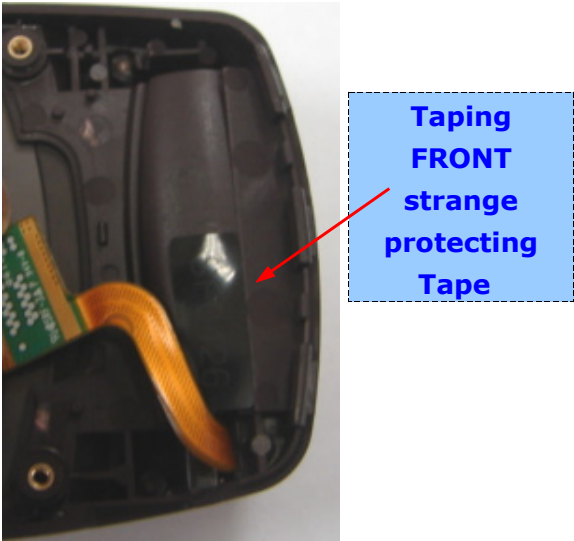
<p>1</p> 	<p>2</p>  <p>loacte Motor wire between Speaker and Motor</p>
<p>1) Insert FPCB to FOLDER LOWER, please caution FPCB insert part.</p> <p>* caution</p> <p>1) Be careful about the scratch occurrence or Framework damage.</p> <p>2) Be careful about the tear of LCD FPCB</p>	<p>1) Insert SPEAKER and MOTOR to LWOER's each part location.</p> <p>* caution</p> <p>1) You have to loacte Motor wire between Speaker and Motor</p>
<p>3</p> 	<p>4</p> 
<p>1) please lock FOLDER UPPER with following locking order(1->2->3->4)</p> <p>* caution</p> <p>1) Be careful about the scratch occurrence or Framework damage.</p>	<p>1) Screw down below red circle.(M1.4xL3)</p> <p>* caution</p> <p>1) Be careful about the scratch occurrence or Framework damage.</p> <p>2) Using (1.0 ± 0.1 Kg_f/cm²)</p>

<p>5</p> 	<p>6</p> 
<p>1) Insert SCREW CAP below red circle. * caution 1) Be careful about the scratch occurrence or Framework damage.</p>	<p>1) Insert LCD FPCB between FRONT HINGE Hole Side. 2) Assemble FOLDER and Front, please push FOLDER's hinge boss, insert the boss into FRONT hinge Hole. * caution 1) Be careful about the scratch occurrence or Framework damage.</p>
<p>7</p> 	<p>8</p> 
<p>1) Taping FRONT strange protecting tape. * caution 1) Be careful about the tear of LCD FPCB</p>	<p>1) Insert KEYPAD. * caution 1) You have to caution KEYPAD Hole.</p>

9

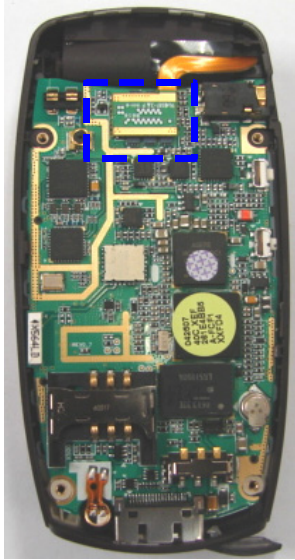

- 1) Insert MAIN PBA.
 - 2) Connect LCD FPCB with MAIN PBA
- * caution**
- 1) Be careful about the tear of LCD FPCB
 - 2) Be careful a damage of PBA components.

10

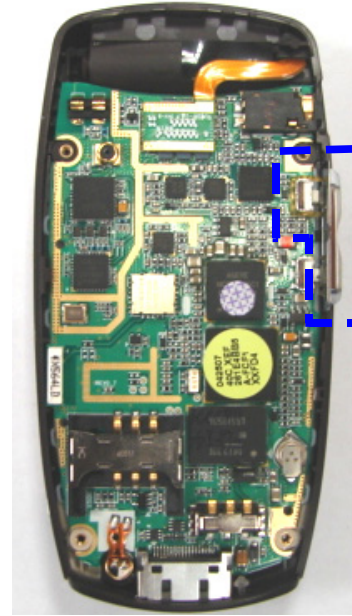

- 1) Insert SIDE KEY below blue Position.

11

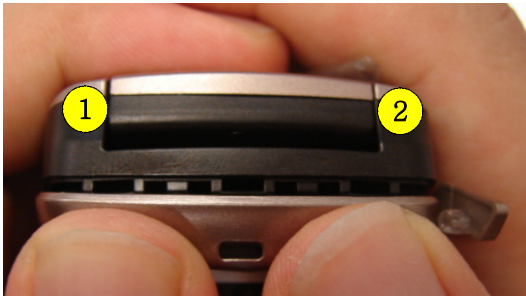

- 1) Please open EAR COVER from REAR
 - 2) Assemble FRONT with REAR.
 - 3) You have to follow assembling order (below yellow circle 1 -> 2)
- * caution**
- 1) Be careful about the scratch occurrence or Framework damage.
 - 2) When you assemble REAR , you have to check VOLUME KEY omitting.

12

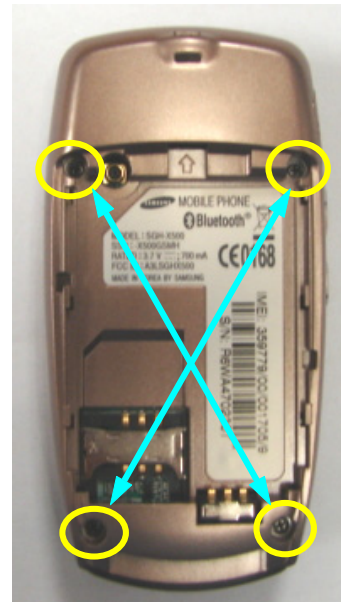

- 1) SCREW 4POINT (below 4 points)
M1.4* L3
- * caution**
- 1) Be careful about the scratch occurrence

6-3. LCD KIT

1

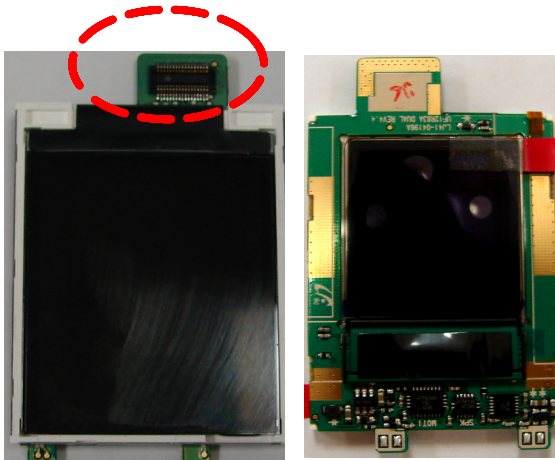

- 1) Check LCD .
 - . Check LCD protecting vinyl (Front / Back)
 - . Check LCD connector's soldering condition and strange material.

*** caution**

- 1) Follow LCD using consideration

2

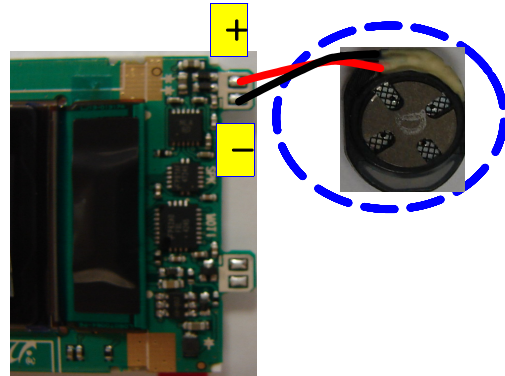

- 1) Put LCD on SPEAKER soldering JIG.
- 2) Solder 2 SPEAKER soldering point.
 - Solder red wire at + indication.
 - . soldering temperature : 350 ~380℃
 - . soldering time : MAX 2 secs

*** caution**

- 1) Follow LCD using consideration
- 2) Check SPEAKER WIRE bonding condition and external appearance.

3

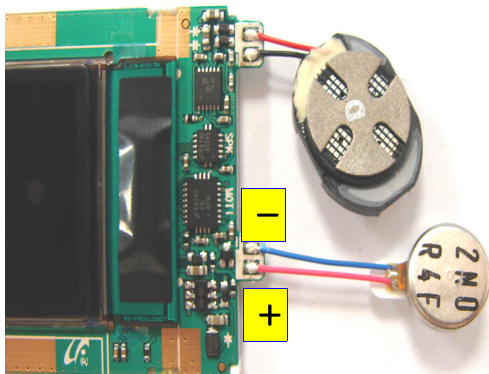

- 1) Put LCD on Motor soldering JIG.
- 2) Solder 2 Motor soldering point.
 - Solder red wire at + indication.
 - . soldering temperature : 350 ~380℃
 - . soldering time : MAX 2 secs

*** caution**

- 1) Follow LCD using consideration
- 2) Check Motor WIRE bonding condition and external appearance.

4

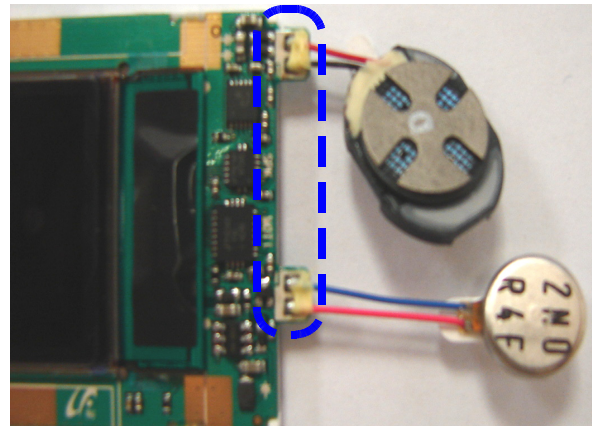

- 1) Do bonding on 2 soldering point.

*** caution**

- 1) Follow LCD using consideration
- 2) Be careful that BONDING Height is too high.
- 3) BOND is prohibited over SILK line.
- 4) Do bonding SPK, MOTOR soldering part and some wire.

5

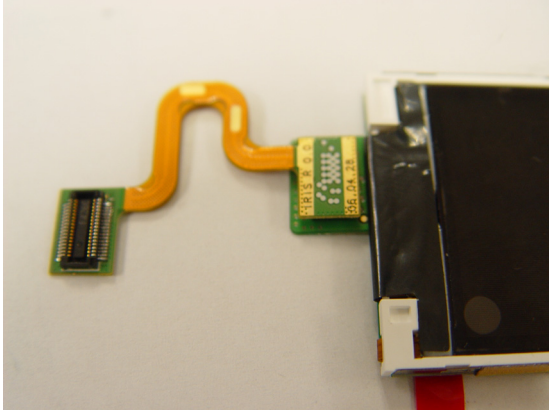

1) Connect CON TO CON with LCD

*** caution**

1) Follow LCD using consideration

6

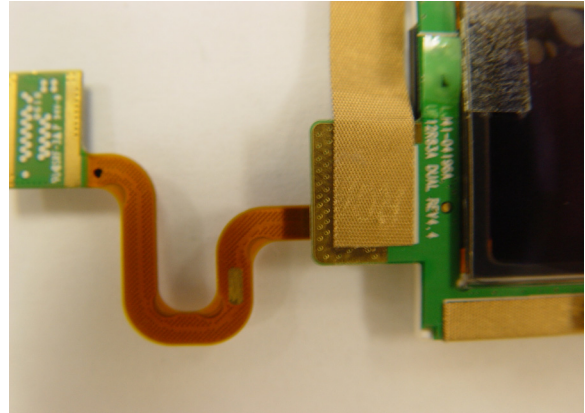

1) Bandage CON TO CON TAPE from topside to Bottomside (Bandage CON TO CON TAPE from SUB LCD to MAIN LCD)

*** caution**

1) Follow LCD using consideration

7

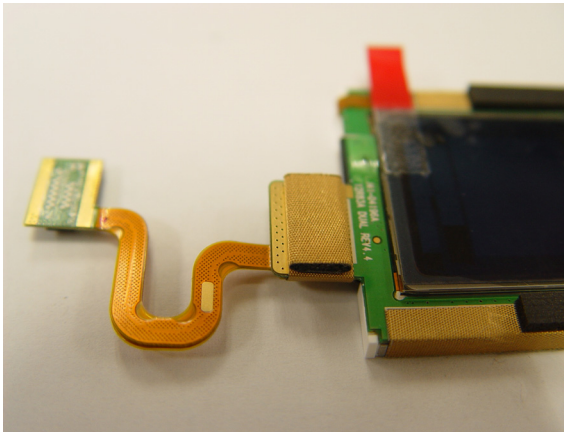

1) Post LCD GASKET to the middle upper of CON TO CON TAPE

*** caution**

1) Follow LCD using consideration

8

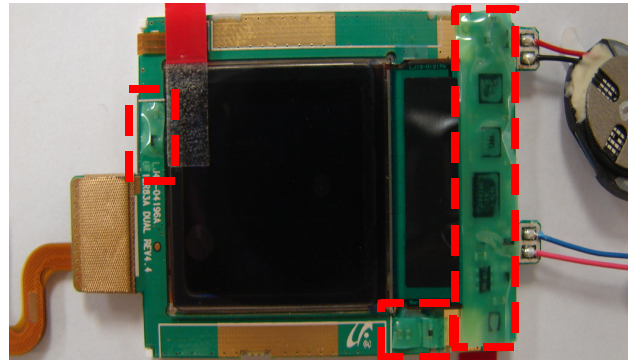

1) Post 3 insulation TAPE see below picture.

*** caution**

1) Be careful strange material or finger mark.

9

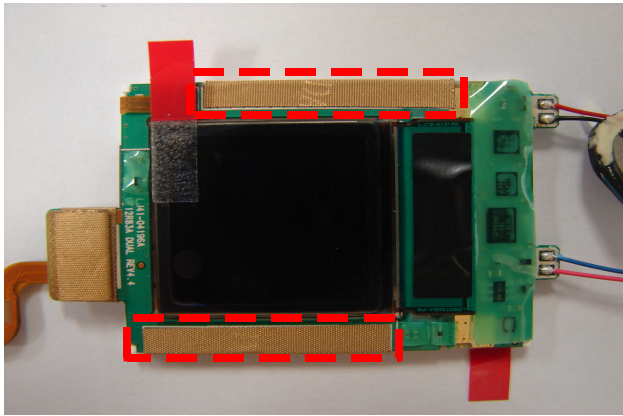

- 1) Following silk line, post 2 electric conduction TAPE, please fold TAPE following silk line .

*** caution**

- 1) Do not go over MAIN LCD part.
- 2) Do not touch to insulation TAPE.
- 3) Be careful strange material or finger mark.

10

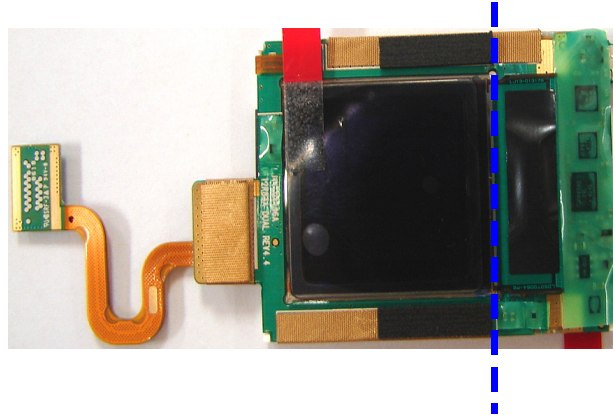

- 1) Post 2 sponge PORON following below blue line.

*** caution**

- 1) Be careful strange material or finger mark.

■ LCD using consideration

- **Please do not touch LCD both sides. (Seize side part)**

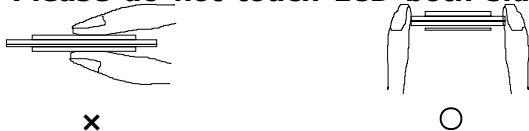

- **please don't give any impact to LCD (finger or pincette)**

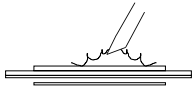

- **When you seize the corner of LCD , please don't give too much force.**

- **please don't touch LCD FPCB part.**

- **if there are any kinds of stain/air bubble/bow/dust, rinse LCD surface with Alcohol and cotton stick.**

- **if there are any strange spots in LCD surface , please don't use those LCD. those LCD are faulty LCD**

- **if there are any kinds of tear/split/damage/short in FPCB, please don't use those LCD.**

7. MAIN Electrical Parts List

SEC CODE	Design LOC	Discription	STATUS
4202-001153	ANT201	ANTENNA-CHIP	SA
4302-001158	BAT101	BATTERY-LI(2ND)	SA
3711-006228	BTC504	HEADER-BATTERY	SA
2203-006562	C100	C-CER,CHIP	SA
2203-006377	C101	C-CER,CHIP	SA
2203-000189	C102	C-CER,CHIP	SA
2203-000254	C103	C-CER,CHIP	SA
2203-000254	C104	C-CER,CHIP	SA
2203-002709	C105	C-CER,CHIP	SNA
2203-006837	C106	C-CER,CHIP	SA
2203-002709	C107	C-CER,CHIP	SNA
2203-000940	C108	C-CER,CHIP	SA
2203-006048	C109	C-CER,CHIP	SA
2203-000812	C110	C-CER,CHIP	SA
2203-000812	C111	C-CER,CHIP	SA
2203-000812	C112	C-CER,CHIP	SA
2203-000233	C113	C-CER,CHIP	SA
2203-006324	C114	C-CER,CHIP	SA
2203-006348	C115	C-CER,CHIP	SA
2203-006837	C116	C-CER,CHIP	SA
2203-006348	C117	C-CER,CHIP	SA
2203-006348	C118	C-CER,CHIP	SA
2203-002709	C119	C-CER,CHIP	SNA
2203-006348	C120	C-CER,CHIP	SA
2203-000254	C121	C-CER,CHIP	SA
2203-001405	C122	C-CER,CHIP	SA
2203-001405	C123	C-CER,CHIP	SA
2203-002709	C124	C-CER,CHIP	SNA
2203-006348	C125	C-CER,CHIP	SA
2203-006361	C126	C-CER,CHIP	SA
2203-006825	C127	C-CER,CHIP	SA
2404-001268	C128	C-TA,CHIP	SA
2203-006048	C200	C-CER,CHIP	SA
2203-006048	C201	C-CER,CHIP	SA
2203-000254	C202	C-CER,CHIP	SA
2203-000254	C203	C-CER,CHIP	SA
2203-006048	C204	C-CER,CHIP	SA
2203-000254	C205	C-CER,CHIP	SA
2203-000254	C206	C-CER,CHIP	SA

Main Electrical Parts List

SEC CODE	Design LOC	Discription	STATUS
2203-006048	C207	C-CER,CHIP	SA
2203-000254	C208	C-CER,CHIP	SA
2203-006048	C209	C-CER,CHIP	SA
2203-001432	C210	C-CER,CHIP	SA
2203-006048	C213	C-CER,CHIP	SA
2203-006562	C214	C-CER,CHIP	SA
2203-006048	C215	C-CER,CHIP	SA
2203-000995	C216	C-CER,CHIP	SA
2203-006048	C217	C-CER,CHIP	SA
2203-006562	C218	C-CER,CHIP	SA
2203-006562	C219	C-CER,CHIP	SA
2203-002709	C220	C-CER,CHIP	SNA
2203-006348	C221	C-CER,CHIP	SA
2203-000386	C223	C-CER,CHIP	SA
2203-000386	C224	C-CER,CHIP	SA
2203-002709	C225	C-CER,CHIP	SNA
2203-002709	C226	C-CER,CHIP	SNA
2203-006562	C300	C-CER,CHIP	SA
2203-000233	C301	C-CER,CHIP	SA
2203-000812	C302	C-CER,CHIP	SA
2203-005481	C303	C-CER,CHIP	SA
2203-006824	C304	C-CER,CHIP	SA
2203-002709	C305	C-CER,CHIP	SNA
2404-001225	C306	C-TA,CHIP	SA
2203-002709	C307	C-CER,CHIP	SNA
2203-002709	C308	C-CER,CHIP	SNA
2203-005481	C309	C-CER,CHIP	SA
2203-000628	C310	C-CER,CHIP	SA
2203-002709	C311	C-CER,CHIP	SNA
2203-000812	C312	C-CER,CHIP	SA
2203-006348	C313	C-CER,CHIP	SA
2203-002709	C314	C-CER,CHIP	SNA
2404-001381	C315	C-TA,CHIP	SA
2203-006562	C316	C-CER,CHIP	SA
2203-000311	C317	C-CER,CHIP	SA
2203-000311	C318	C-CER,CHIP	SA
2203-000940	C319	C-CER,CHIP	SA
2203-006562	C320	C-CER,CHIP	SA

SEC CODE	Design LOC	Discription	STATUS
2203-000311	C321	C-CER,CHIP	SA
2203-000940	C322	C-CER,CHIP	SA
2404-001151	C323	C-TA,CHIP	SA
2203-000628	C324	C-CER,CHIP	SA
2203-006562	C325	C-CER,CHIP	SA
2203-000940	C327	C-CER,CHIP	SA
2203-001405	C328	C-CER,CHIP	SA
2404-001225	C329	C-TA,CHIP	SA
2203-000278	C330	C-CER,CHIP	SA
2203-006562	C331	C-CER,CHIP	SA
2203-000654	C332	C-CER,CHIP	SA
2203-000940	C334	C-CER,CHIP	SA
2404-001225	C335	C-TA,CHIP	SA
2203-000278	C336	C-CER,CHIP	SA
2203-000654	C337	C-CER,CHIP	SA
2203-001072	C338	C-CER,CHIP	SA
2203-000438	C339	C-CER,CHIP	SA
2203-000438	C340	C-CER,CHIP	SA
2203-000812	C341	C-CER,CHIP	SA
2203-000812	C342	C-CER,CHIP	SA
2203-000812	C343	C-CER,CHIP	SA
2203-000812	C344	C-CER,CHIP	SA
2203-000438	C346	C-CER,CHIP	SA
2203-000438	C347	C-CER,CHIP	SA
2203-006048	C400	C-CER,CHIP	SA
2203-000812	C401	C-CER,CHIP	SA
2203-000812	C402	C-CER,CHIP	SA
2203-006562	C403	C-CER,CHIP	SA
2203-006562	C404	C-CER,CHIP	SA
2203-006048	C405	C-CER,CHIP	SA
2203-006562	C406	C-CER,CHIP	SA
2404-001381	C407	C-TA,CHIP	SA
2203-006194	C500	C-CER,CHIP	SA
2203-006423	C501	C-CER,CHIP	SA
2203-000254	C502	C-CER,CHIP	SA
2203-006048	C503	C-CER,CHIP	SA
2203-006048	C504	C-CER,CHIP	SA
2203-000254	C505	C-CER,CHIP	SA
2203-006681	C506	C-CER,CHIP	SA

Main Electrical Parts List

SEC CODE	Design LOC	Discription	STATUS
2203-002709	C507	C-CER,CHIP	SNA
2404-001274	C508	C-TA,CHIP	SA
2203-006048	C509	C-CER,CHIP	SA
2203-005777	C600	C-CER,CHIP	SA
2203-005731	C601	C-CER,CHIP	SA
2203-005777	C602	C-CER,CHIP	SA
2203-006556	C604	C-CER,CHIP	SA
2203-006410	C606	C-CER,CHIP	SA
2203-006318	C607	C-CER,CHIP	SA
2203-006556	C608	C-CER,CHIP	SA
2203-005682	C609	C-CER,CHIP	SA
2203-005736	C610	C-CER,CHIP	SA
2203-005682	C611	C-CER,CHIP	SA
2203-006318	C612	C-CER,CHIP	SA
2203-005736	C613	C-CER,CHIP	SA
2203-006194	C614	C-CER,CHIP	SA
2203-006194	C615	C-CER,CHIP	SA
2203-006318	C616	C-CER,CHIP	SA
2203-005736	C617	C-CER,CHIP	SA
2203-006318	C618	C-CER,CHIP	SA
2203-006194	C619	C-CER,CHIP	SA
2203-006194	C620	C-CER,CHIP	SA
2203-006423	C621	C-CER,CHIP	SA
2203-006423	C622	C-CER,CHIP	SA
2203-006648	C623	C-CER,CHIP	SA
2203-006423	C624	C-CER,CHIP	SA
2203-006423	C625	C-CER,CHIP	SA
2404-001374	C626	C-TA,CHIP	SA
2203-005682	C627	C-CER,CHIP	SA
2203-005736	C628	C-CER,CHIP	SA
2203-005682	C629	C-CER,CHIP	SA
2203-005682	C630	C-CER,CHIP	SA
2203-005682	C631	C-CER,CHIP	SA
2203-002668	C632	C-CER,CHIP	SA
2203-005234	C633	C-CER,CHIP	SA
0404-001172	D1	DIODE-SCHOTTKY	SA
3722-002067	EAR302	JACK-EAR PHONE	SA
1405-001161	F401	VARISTOR	SA

SEC CODE	Design LOC	Discription	STATUS
1405-001161	F402	VARISTOR	SA
1405-001161	F404	VARISTOR	SA
1405-001161	F405	VARISTOR	SA
1405-001161	F407	VARISTOR	SA
2904-001592	F601	FILTER-SAW	SA
2904-001599	F602	FILTER-SAW	SA
2904-001600	F603	FILTER-SAW	SA
3711-005793	HEA1	HEADER-BOARD TO BOARD	SA
3710-001611	IFC501	CONNECTOR-INTERFACE	SA
2703-002734	L100	INDUCTOR-SMD	SA
3301-001438	L200	BEAD-SMD	SA
3301-001534	L203	BEAD-SMD	SA
3301-001534	L300	BEAD-SMD	SA
2703-002313	L301	INDUCTOR-SMD	SA
2703-002313	L302	INDUCTOR-SMD	SA
3301-001158	L303	BEAD-SMD	SA
3301-001158	L304	BEAD-SMD	SA
GH71-06338A	L600	NPR-BRACKET ANT CONTACT	SA
2703-002485	L601	INDUCTOR-SMD	SA
2703-002858	L603	INDUCTOR-SMD	SA
2703-002858	L604	INDUCTOR-SMD	SA
GH71-06338A	L605	NPR-BRACKET ANT CONTACT	SA
2703-002313	L606	INDUCTOR-SMD	SA
2703-002544	L608	INDUCTOR-SMD	SA
2703-002544	L609	INDUCTOR-SMD	SA
2703-002558	L610	INDUCTOR-SMD	SA
2703-002608	L611	INDUCTOR-SMD	SA
2703-001868	L612	INDUCTOR-SMD	SA
0601-002053	LED401	LED	SA
0601-002053	LED402	LED	SA
0601-002053	LED403	LED	SA
0601-002053	LED404	LED	SA
0601-002053	LED405	LED	SA
0601-002053	LED406	LED	SA
0601-002053	LED407	LED	SA
0601-002053	LED408	LED	SA
0601-002053	LED409	LED	SA
0601-002053	LED410	LED	SA
0601-002053	LED411	LED	SA

Main Electrical Parts List

SEC CODE	Design LOC	Discription	STATUS
0601-002053	LED412	LED	SA
0601-002053	LED413	LED	SA
0601-002053	LED414	LED	SA
2801-004466	OSC202	CRYSTAL-SMD	SA
2801-004455	OSC601	CRYSTAL-SMD	SA
1203-003432	Q200	IC-POSI.FIXED REG.	SA
0501-000225	Q300	TR-SMALL SIGNAL	SA
2007-008483	R100	R-CHIP	SA
2007-009160	R101	R-CHIP	SA
2007-008137	R102	R-CHIP	SA
2007-000157	R103	R-CHIP	SA
2007-000141	R104	R-CHIP	SA
2007-008419	R107	R-CHIP	SA
2007-008055	R108	R-CHIP	SA
2007-008055	R109	R-CHIP	SA
2007-007308	R112	R-CHIP	SA
2007-007314	R113	R-CHIP	SA
2007-007136	R114	R-CHIP	SA
2007-000157	R116	R-CHIP	SA
2007-000138	R117	R-CHIP	SA
2007-000146	R201	R-CHIP	SA
2007-000162	R202	R-CHIP	SA
2007-000171	R203	R-CHIP	SA
2007-000171	R204	R-CHIP	SA
2007-000171	R205	R-CHIP	SA
2007-000171	R206	R-CHIP	SA
2007-000171	R207	R-CHIP	SA
2007-000157	R208	R-CHIP	SA
2007-000162	R210	R-CHIP	SA
2007-008483	R211	R-CHIP	SA
2007-007142	R212	R-CHIP	SA
2007-000157	R213	R-CHIP	SA
2007-007528	R214	R-CHIP	SA
2007-000139	R215	R-CHIP	SA
2007-000139	R216	R-CHIP	SA
2007-001290	R217	R-CHIP	SA
2007-001290	R218	R-CHIP	SA
2007-000171	R219	R-CHIP	SA

SEC CODE	Design LOC	Discription	STATUS
2007-000171	R223	R-CHIP	SA
2007-000157	R224	R-CHIP	SA
2007-007306	R300	R-CHIP	SA
2007-000137	R301	R-CHIP	SA
2007-000172	R302	R-CHIP	SA
2007-000146	R303	R-CHIP	SA
2007-000171	R304	R-CHIP	SA
2007-000146	R305	R-CHIP	SA
2007-000148	R306	R-CHIP	SA
2007-000172	R307	R-CHIP	SA
2007-000148	R308	R-CHIP	SA
2007-000157	R309	R-CHIP	SA
2007-000148	R310	R-CHIP	SA
2007-000171	R311	R-CHIP	SA
2007-000171	R312	R-CHIP	SA
2007-007142	R313	R-CHIP	SA
2007-000159	R314	R-CHIP	SA
2007-007142	R315	R-CHIP	SA
2007-000171	R316	R-CHIP	SA
2007-000159	R317	R-CHIP	SA
2007-000141	R318	R-CHIP	SA
2007-000141	R319	R-CHIP	SA
2007-001119	R320	R-CHIP	SA
2007-000162	R321	R-CHIP	SA
2007-000171	R322	R-CHIP	SA
2007-001323	R323	R-CHIP	SA
2007-007155	R324	R-CHIP	SA
2007-000171	R325	R-CHIP	SA
2007-007142	R326	R-CHIP	SA
2007-000831	R327	R-CHIP	SA
2007-000173	R328	R-CHIP	SA
2007-007142	R329	R-CHIP	SA
2007-000831	R330	R-CHIP	SA
2007-000831	R331	R-CHIP	SA
2007-000171	R333	R-CHIP	SA
2007-000171	R335	R-CHIP	SA
2007-000171	R336	R-CHIP	SA
2007-000173	R337	R-CHIP	SA
2007-000153	R338	R-CHIP	SA

Main Electrical Parts List

SEC CODE	Design LOC	Discription	STATUS
2007-000242	R339	R-CHIP	SA
2007-008516	R340	R-CHIP	SA
2007-008516	R341	R-CHIP	SA
2007-000171	R400	R-CHIP	SA
2007-000162	R401	R-CHIP	SA
2007-000162	R402	R-CHIP	SA
2007-000157	R403	R-CHIP	SA
2007-000157	R404	R-CHIP	SA
2007-000174	R405	R-CHIP	SA
2007-000174	R406	R-CHIP	SA
2007-000174	R407	R-CHIP	SA
2007-000174	R408	R-CHIP	SA
2007-000174	R409	R-CHIP	SA
2007-001290	R410	R-CHIP	SA
2007-001301	R411	R-CHIP	SA
2007-001301	R412	R-CHIP	SA
2007-001301	R413	R-CHIP	SA
2007-001301	R414	R-CHIP	SA
2007-001301	R415	R-CHIP	SA
2007-001292	R416	R-CHIP	SA
2007-001292	R417	R-CHIP	SA
2007-001301	R418	R-CHIP	SA
2007-001301	R419	R-CHIP	SA
2007-001301	R420	R-CHIP	SA
2007-001301	R421	R-CHIP	SA
2007-001290	R423	R-CHIP	SA
2007-001301	R425	R-CHIP	SA
2007-000174	R426	R-CHIP	SA
2007-000174	R427	R-CHIP	SA
2007-000174	R428	R-CHIP	SA
2007-000174	R429	R-CHIP	SA
2007-000174	R430	R-CHIP	SA
2007-008483	R501	R-CHIP	SA
2007-008542	R502	R-CHIP	SA
2007-008419	R503	R-CHIP	SA
2007-008419	R505	R-CHIP	SA
2007-008419	R506	R-CHIP	SA
2007-008419	R507	R-CHIP	SA

SEC CODE	Design LOC	Discription	STATUS
2007-008419	R508	R-CHIP	SA
2007-008419	R509	R-CHIP	SA
2007-000162	R511	R-CHIP	SA
2007-000171	R512	R-CHIP	SA
2007-000171	R513	R-CHIP	SA
2007-008548	R600	R-CHIP	SA
2007-008587	R601	R-CHIP	SA
2007-008045	R602	R-CHIP	SA
2007-008516	R603	R-CHIP	SA
2007-008516	R604	R-CHIP	SA
3705-001358	RFS601	CONNECTOR-COAXIAL	SA
3709-001384	SIM103	CONNECTOR-CARD EDGE	SA
3404-001152	TAC402	SWITCH-TACT	SA
3404-001152	TAC403	SWITCH-TACT	SA
1404-001165	TH101	THERMISTOR-NTC	SA
0801-002529	U103	IC-CMOS LOGIC	SA
1203-003434	U105	IC-DC/DC CONVERTER	SA
1203-003663	U106	IC-BATTERY	SA
1205-002272	U202	IC-TRANSCEIVER	SA
1009-001027	U203	IC-HALL EFFECT S/W	SA
4709-001374	U255	BLUETOOTH MODULE	SA
1201-002240	U301	IC-AUDIO AMP	SA
1001-001306	U303	IC-ANALOG MULTIPLEX	SA
1203-002557	U402	IC-POSI.FIXED REG.	SA
1203-003058	U405	IC-POSI.FIXED REG.	SA
1201-002278	U601	IC-POWER AMP	SA
1205-002683	U602	IC-TRANSCEIVER	SA
1203-004272	UCD102	IC-POWER SUPERVISOR	SA
1002-001441	UCD302	IC-D/A CONVERTER	SA
GH09-00047A	UCP201	IC MICOM	SA
1108-000036	UME501	IC-MCP	SA
1405-001082	VR201	VARISTOR	SA
1405-001082	VR302	VARISTOR	SA
1405-001082	VR305	VARISTOR	SA
1405-001082	VR306	VARISTOR	SA
1405-001082	VR307	VARISTOR	SA
1405-001082	VR308	VARISTOR	SA
1405-001108	VR402	VARISTOR	SA
1405-001108	VR404	VARISTOR	SA

Main Electrical Parts List

SEC CODE	Design LOC	Discription	STATUS
1405-001108	VR405	VARISTOR	SA
1405-001108	VR406	VARISTOR	SA
1405-001108	VR407	VARISTOR	SA
1405-001108	VR410	VARISTOR	SA
1405-001108	VR411	VARISTOR	SA
1405-001108	VR418	VARISTOR	SA
1405-001108	VR419	VARISTOR	SA
1405-001108	VR420	VARISTOR	SA
1405-001108	VR421	VARISTOR	SA
1405-001082	VR502	VARISTOR	SA
1405-001082	VR503	VARISTOR	SA
0406-001150	ZD106	DIODE-TVS	SA
0406-001201	ZD401	DIODE-TVS	SA
0406-001201	ZD402	DIODE-TVS	SA
0406-001201	ZD403	DIODE-TVS	SA
0406-001201	ZD404	DIODE-TVS	SA
0406-001201	ZD405	DIODE-TVS	SA
0406-001201	ZD408	DIODE-TVS	SA
0406-001201	ZD420	DIODE-TVS	SA
0406-001201	ZD421	DIODE-TVS	SA
0403-001547	ZD501	DIODE-ZENER	SA
0406-001208	ZD504	DIODE-TVS	SA
0406-001208	ZD505	DIODE-TVS	SA

8. Block Diagrams

8-1. RF PART

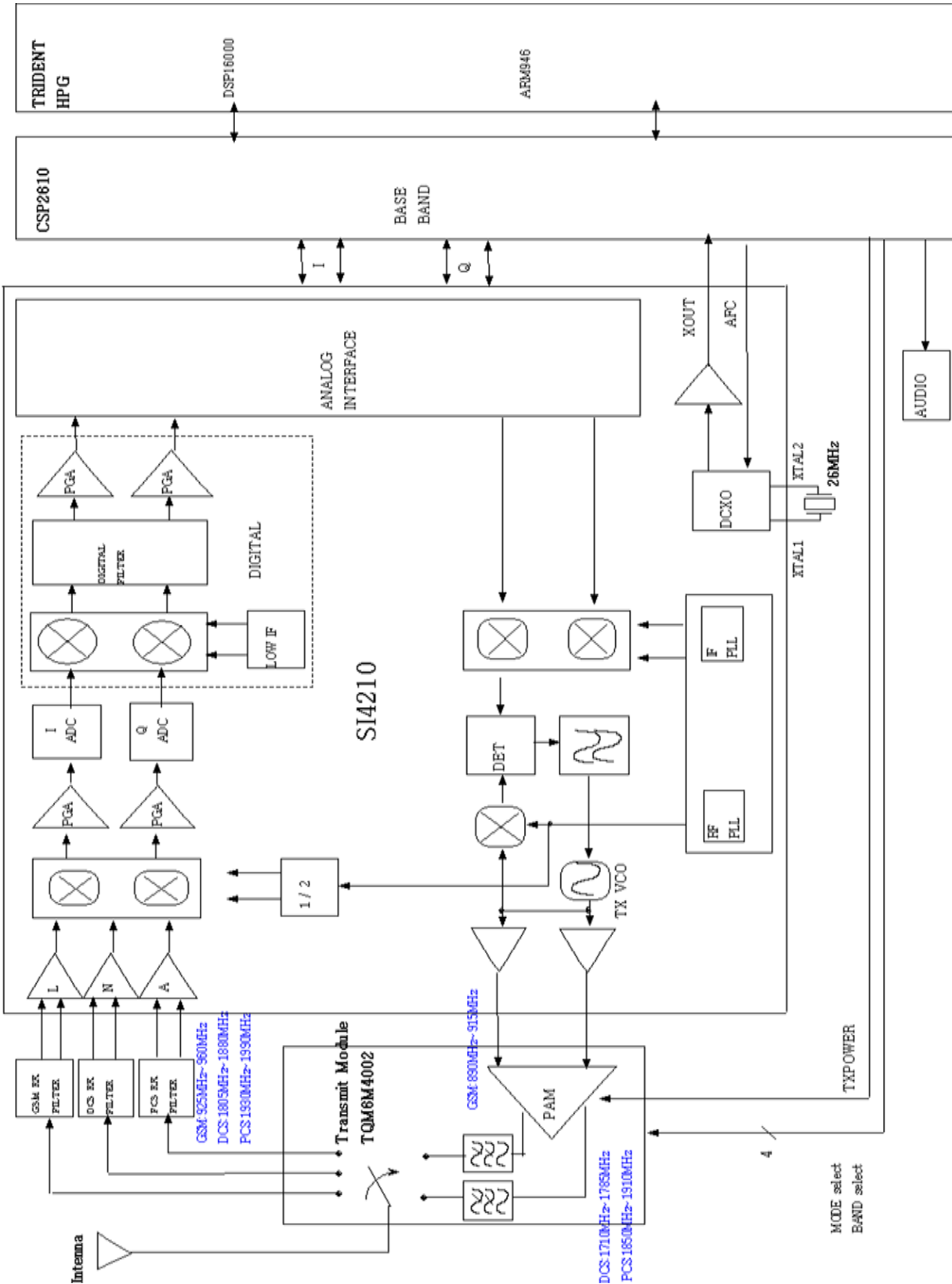

8-2. LOGIC PART

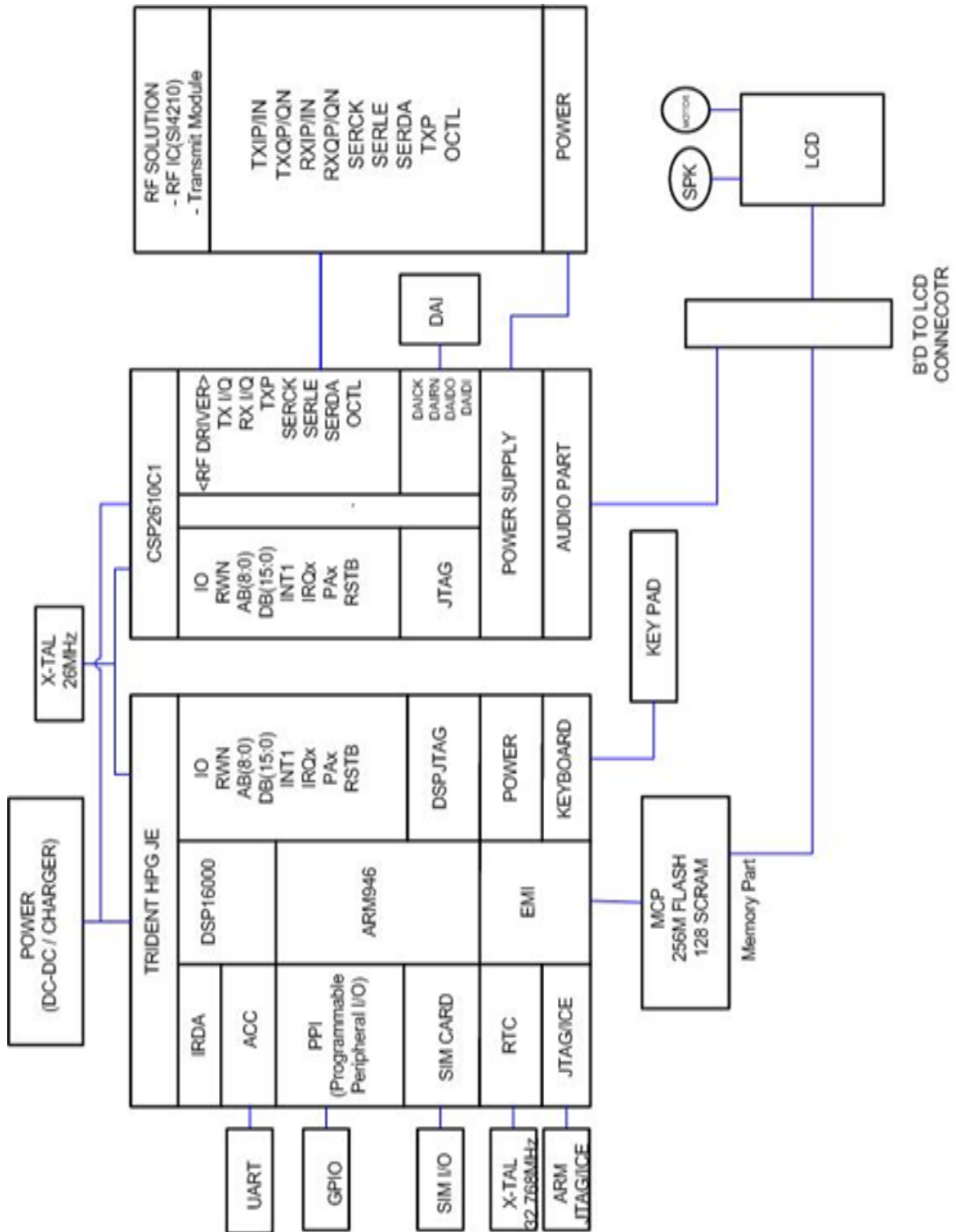

8-3. BT Block

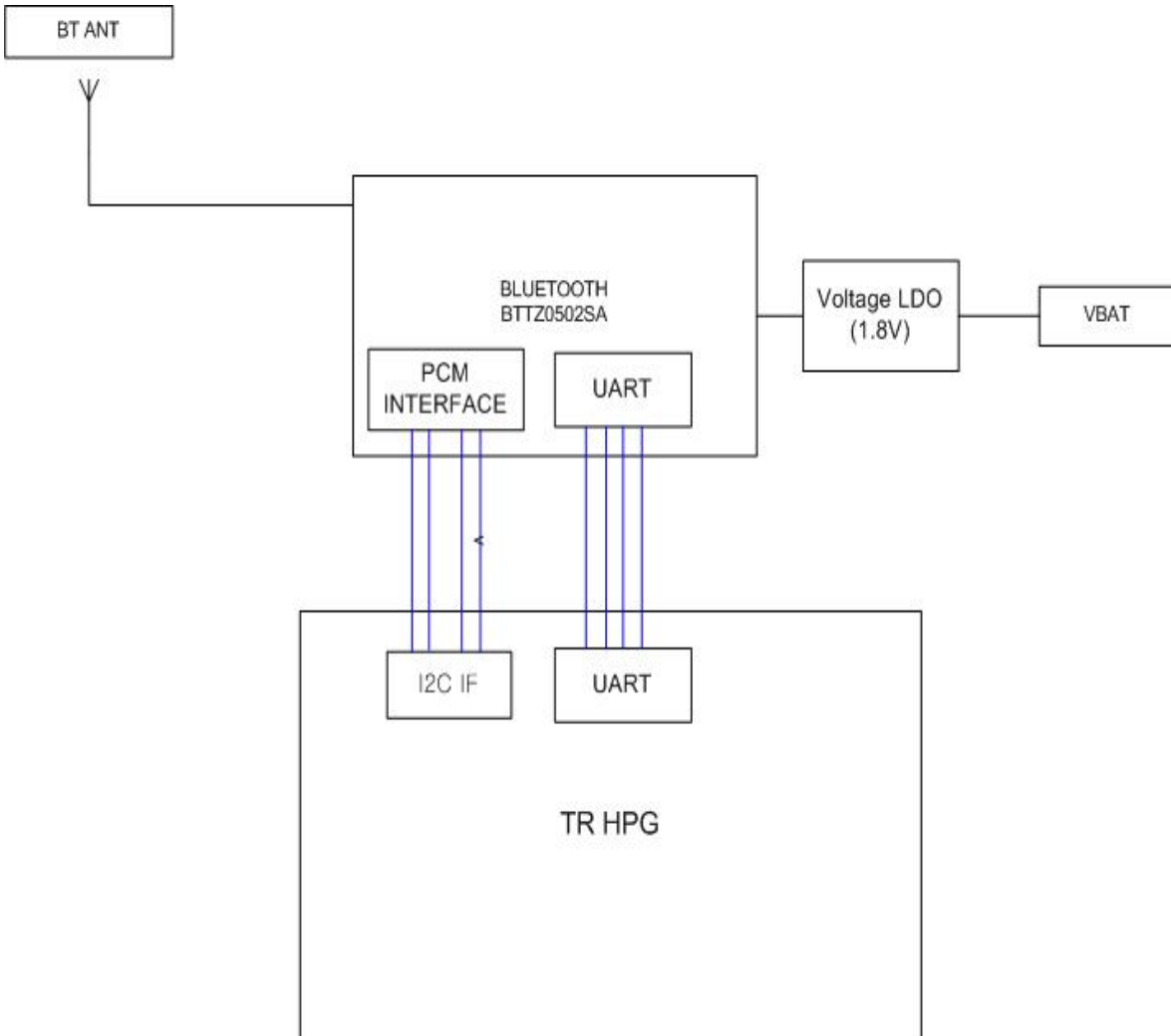

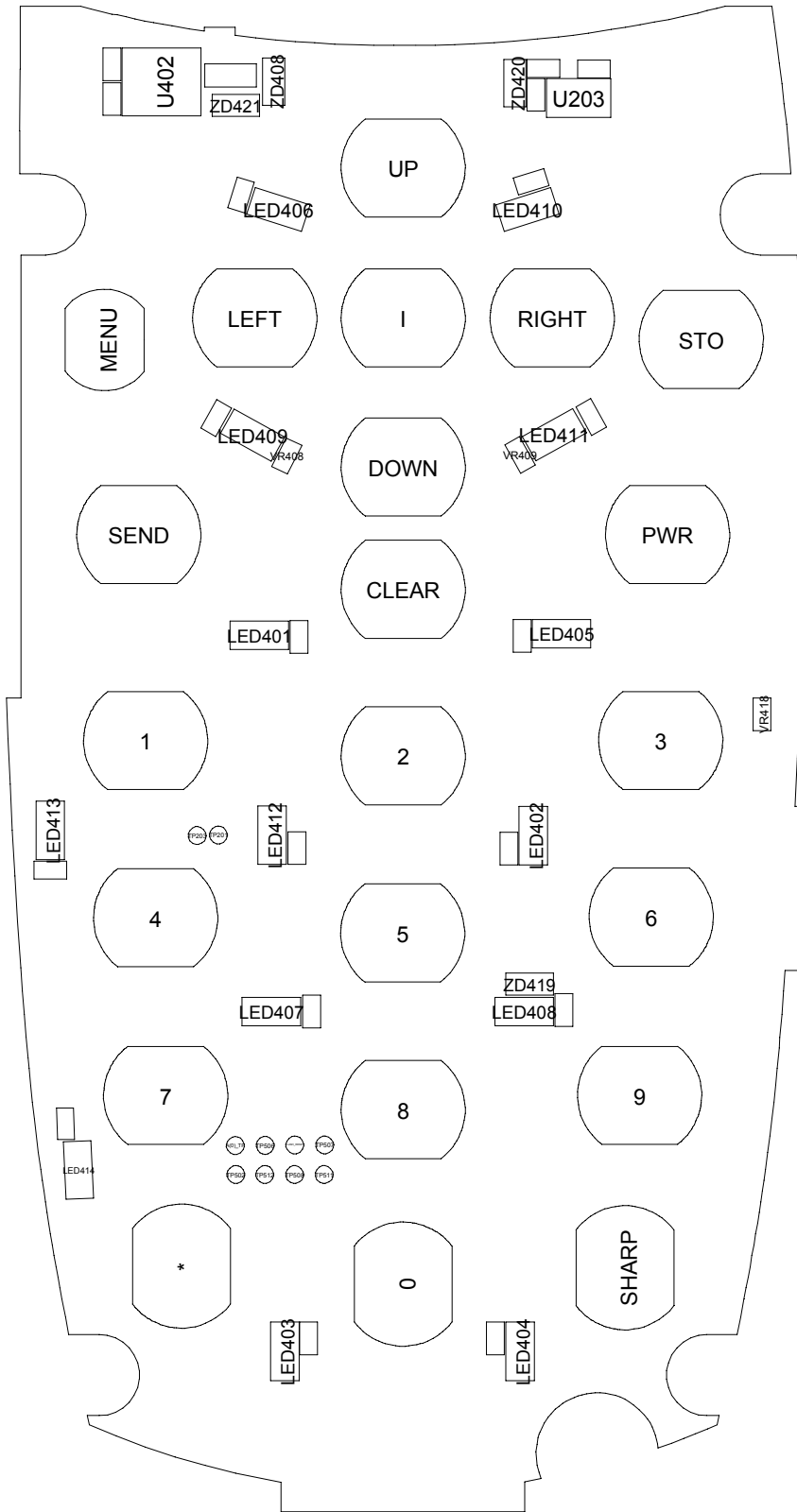

10. Flow Chart of Troubleshooting

10-1. Baseband

10-1-1. Power ON

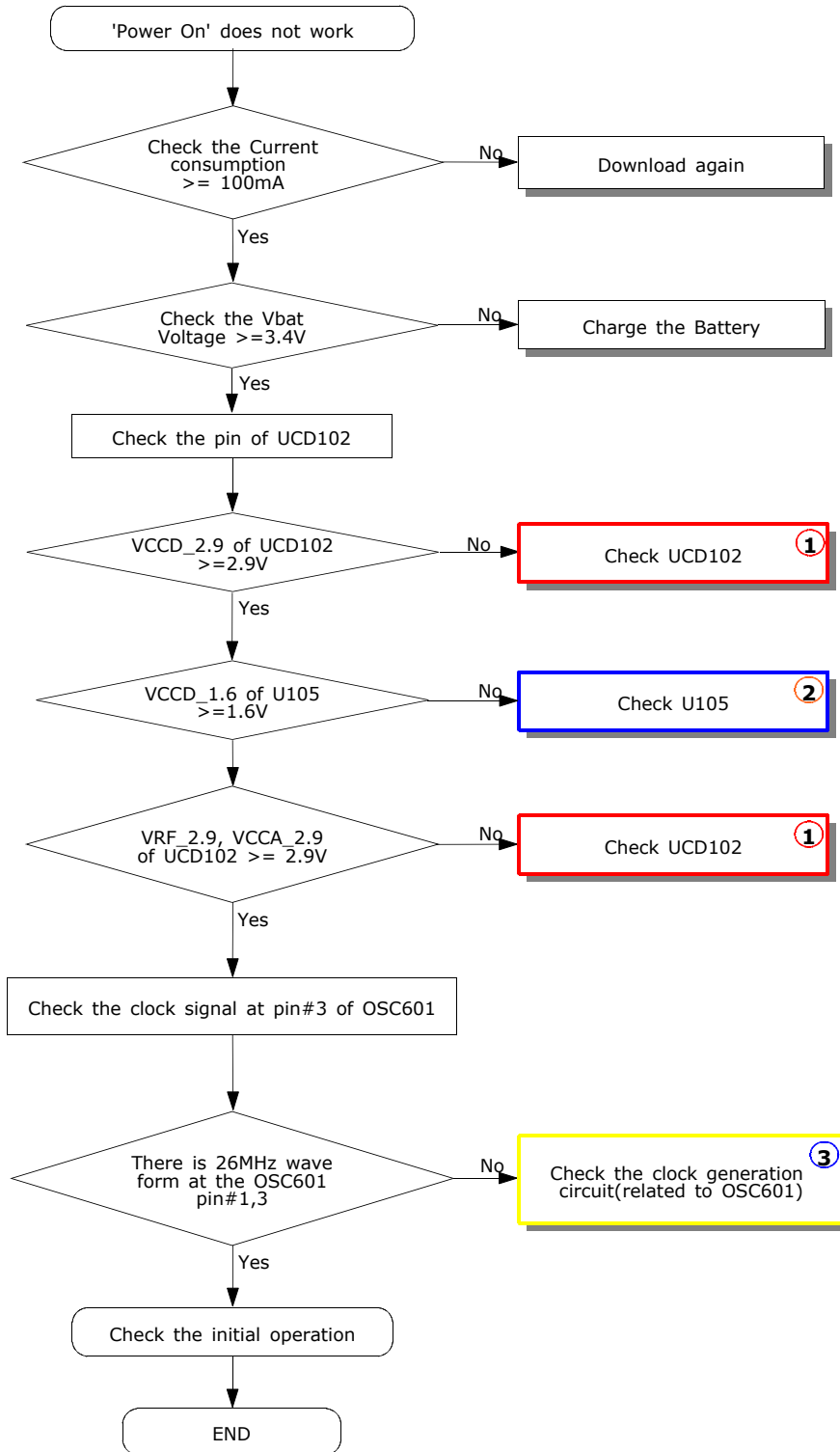

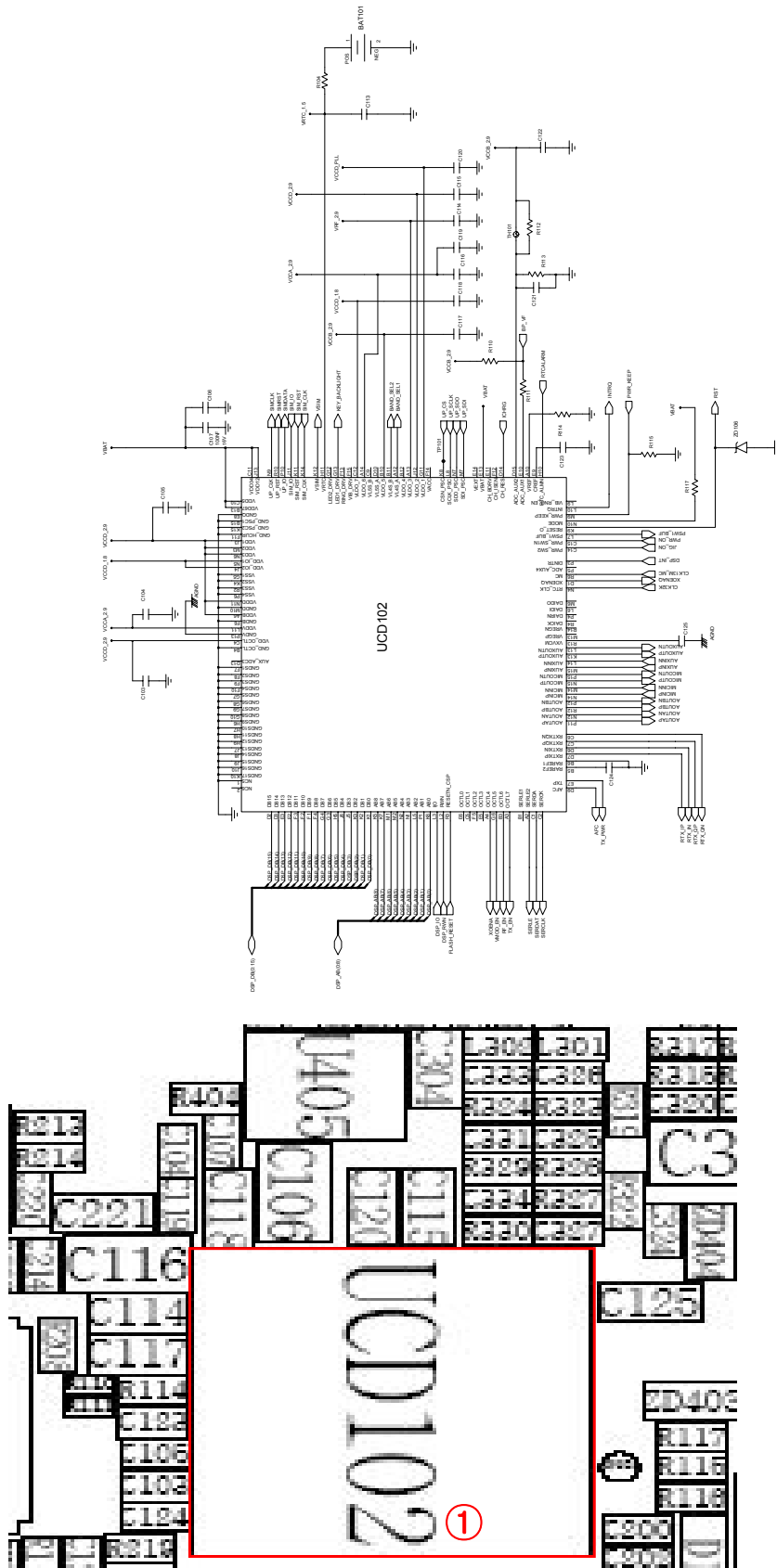

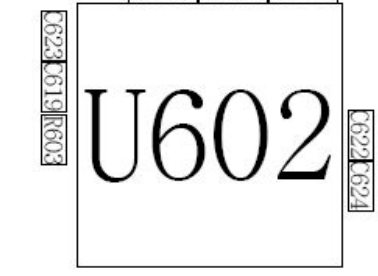
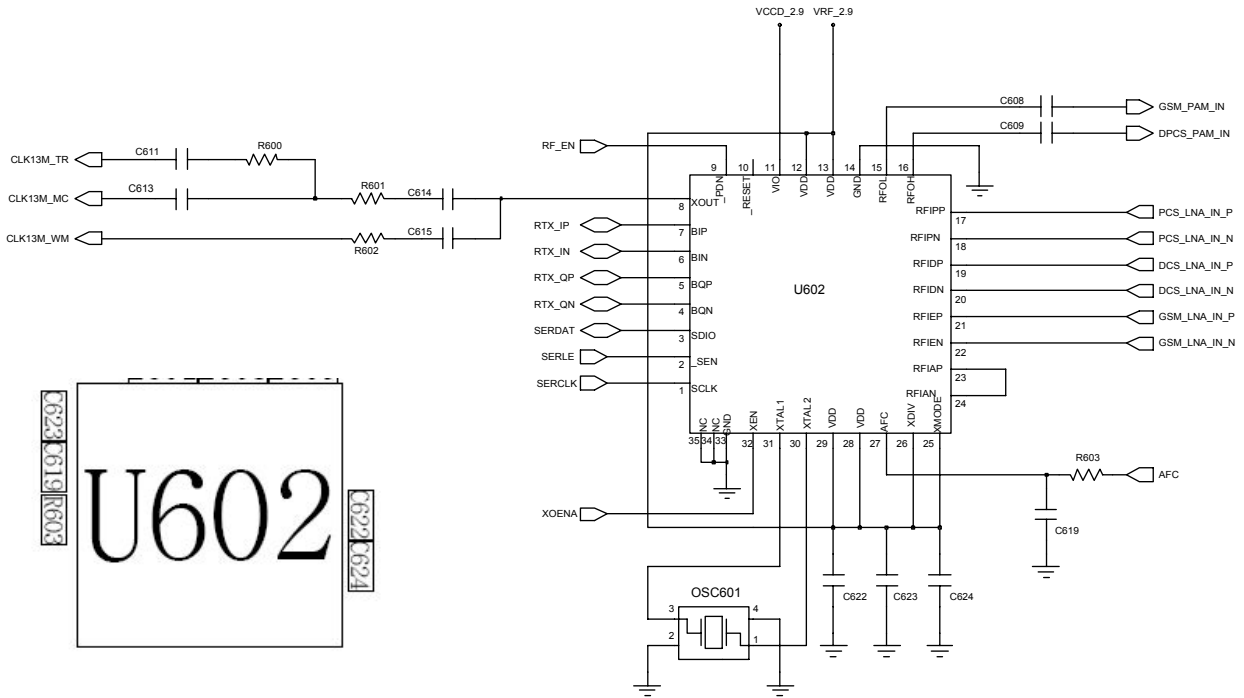
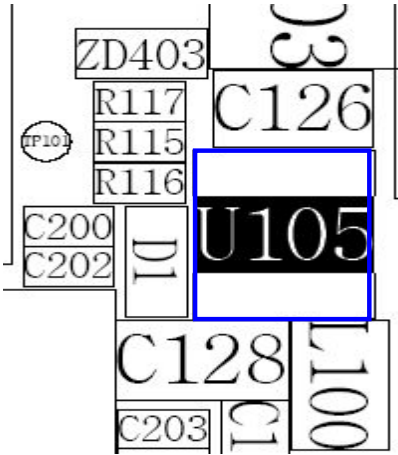
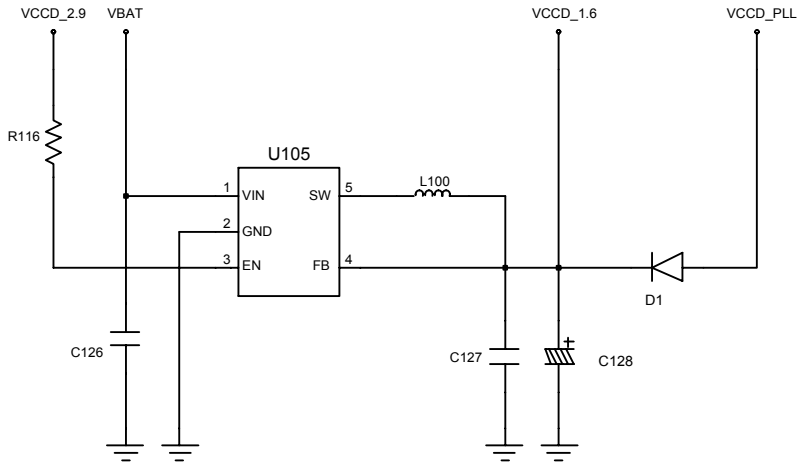

10-1-2. Initial

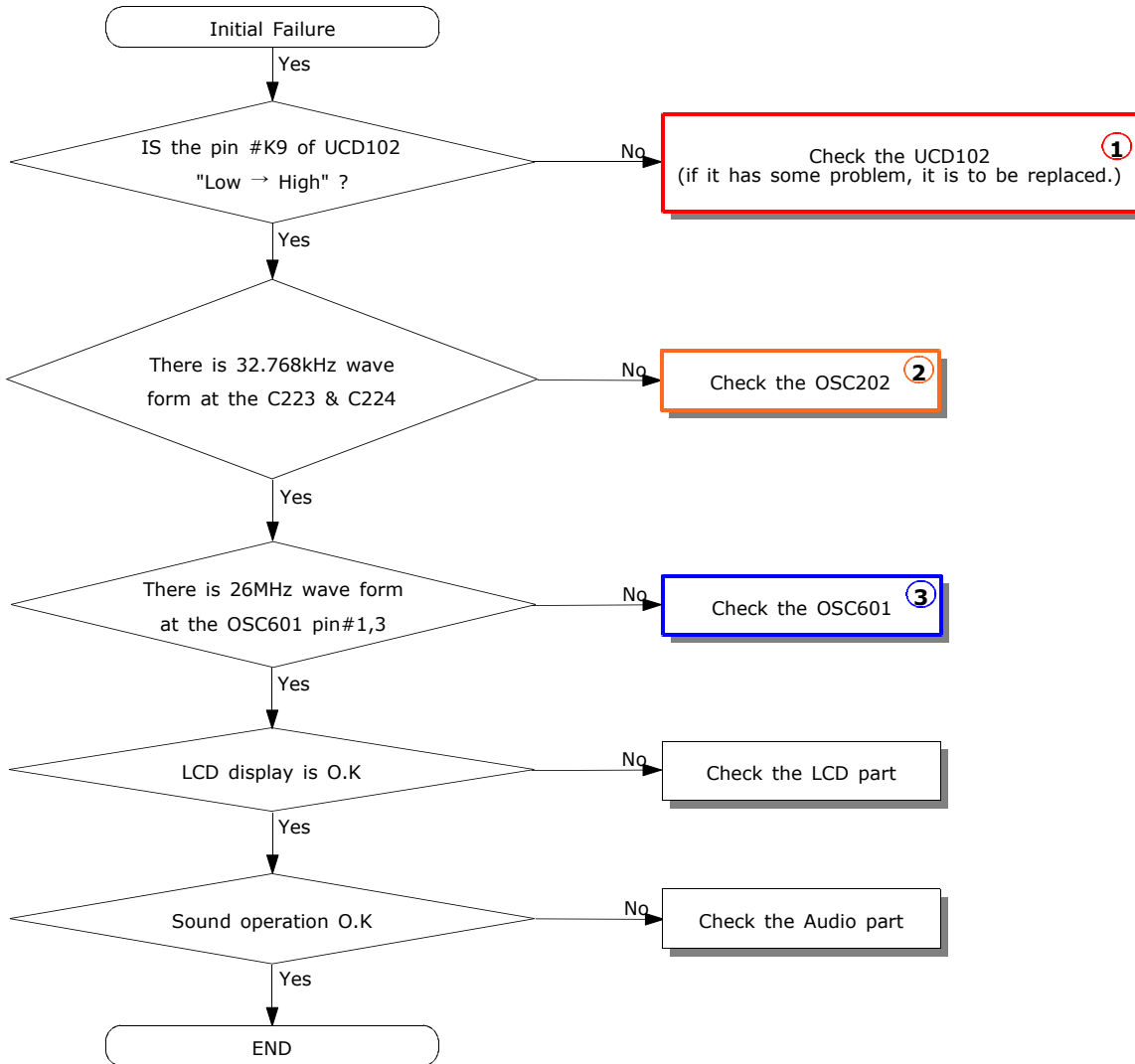

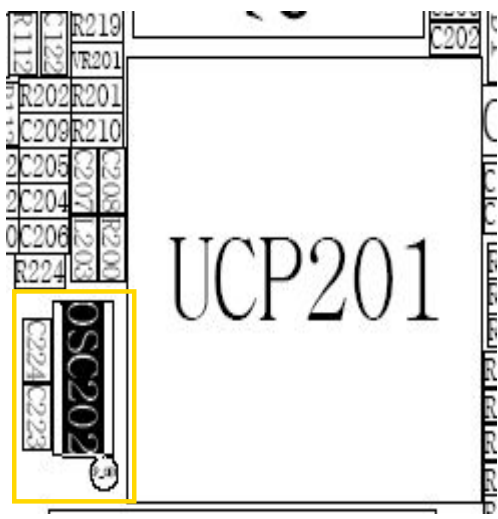
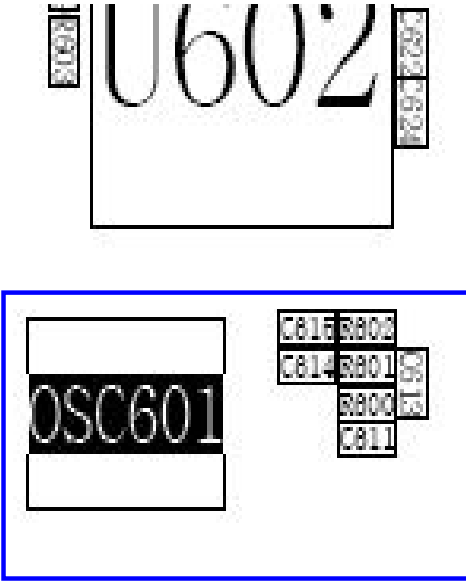
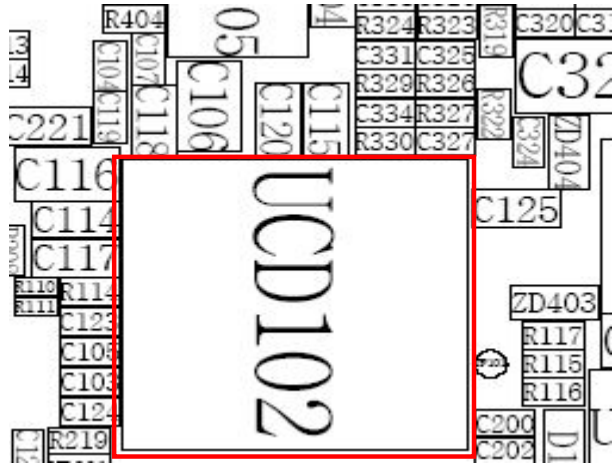
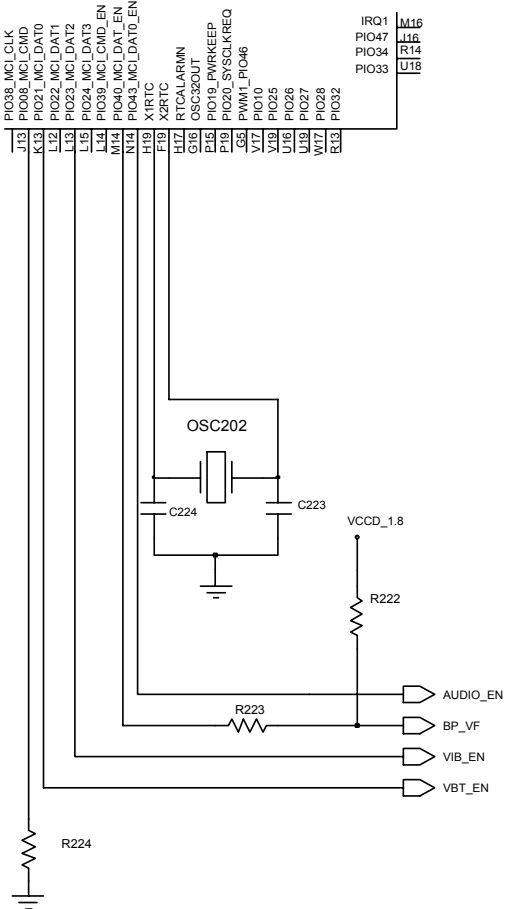

10-1-3. Sim Part

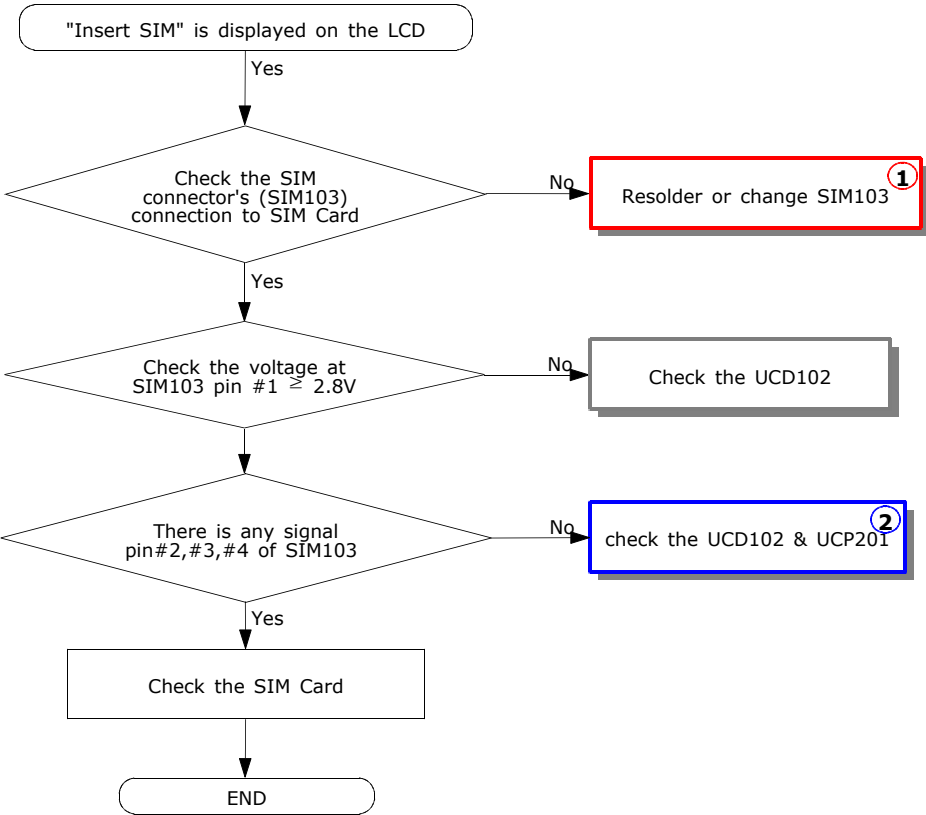

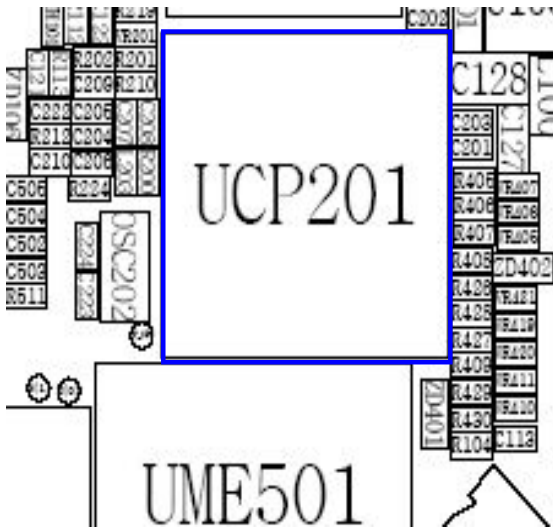
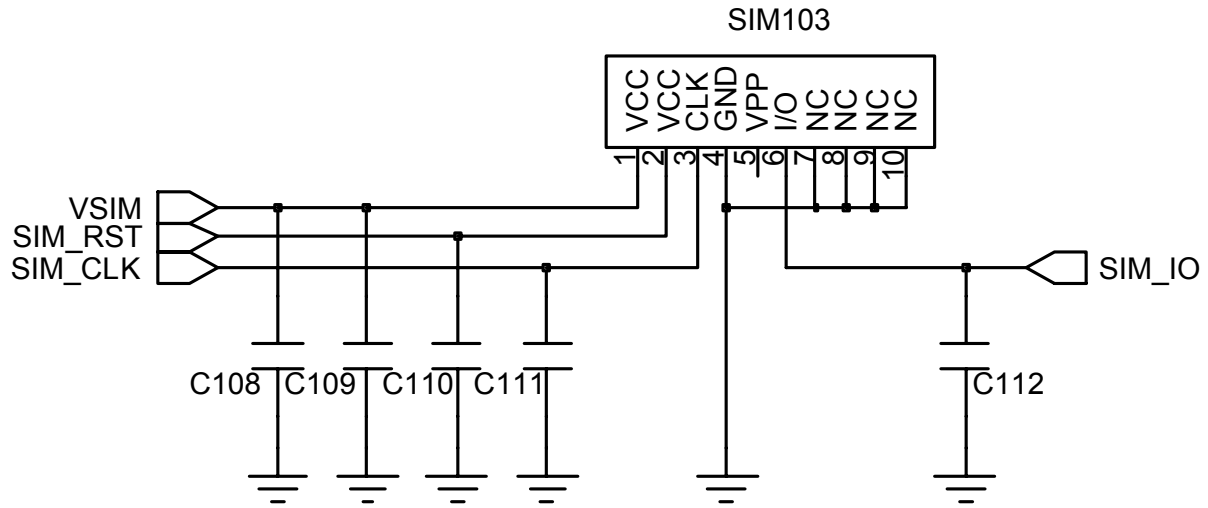

10-1-4. Microphone Part

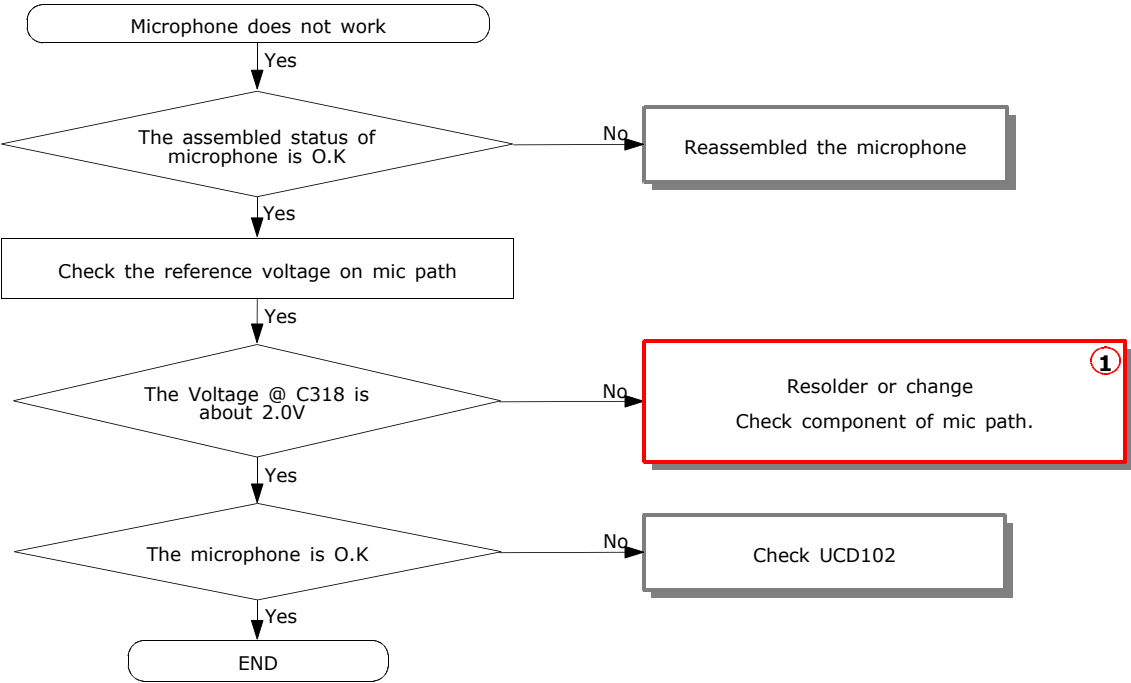

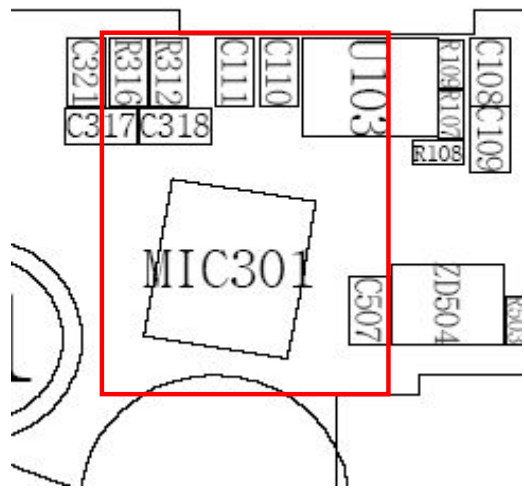
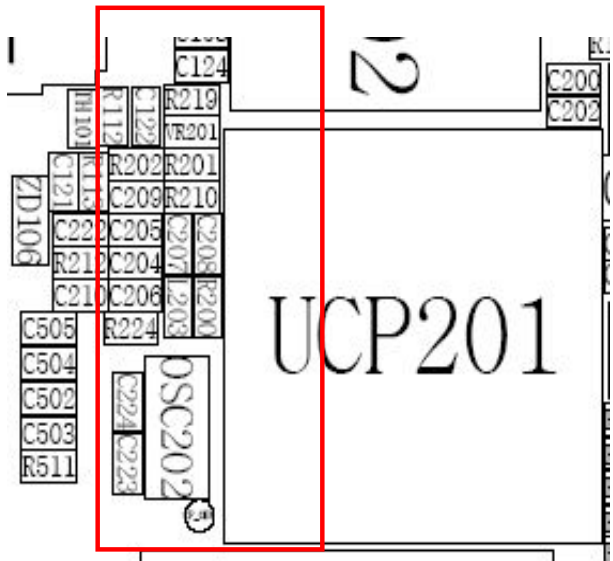
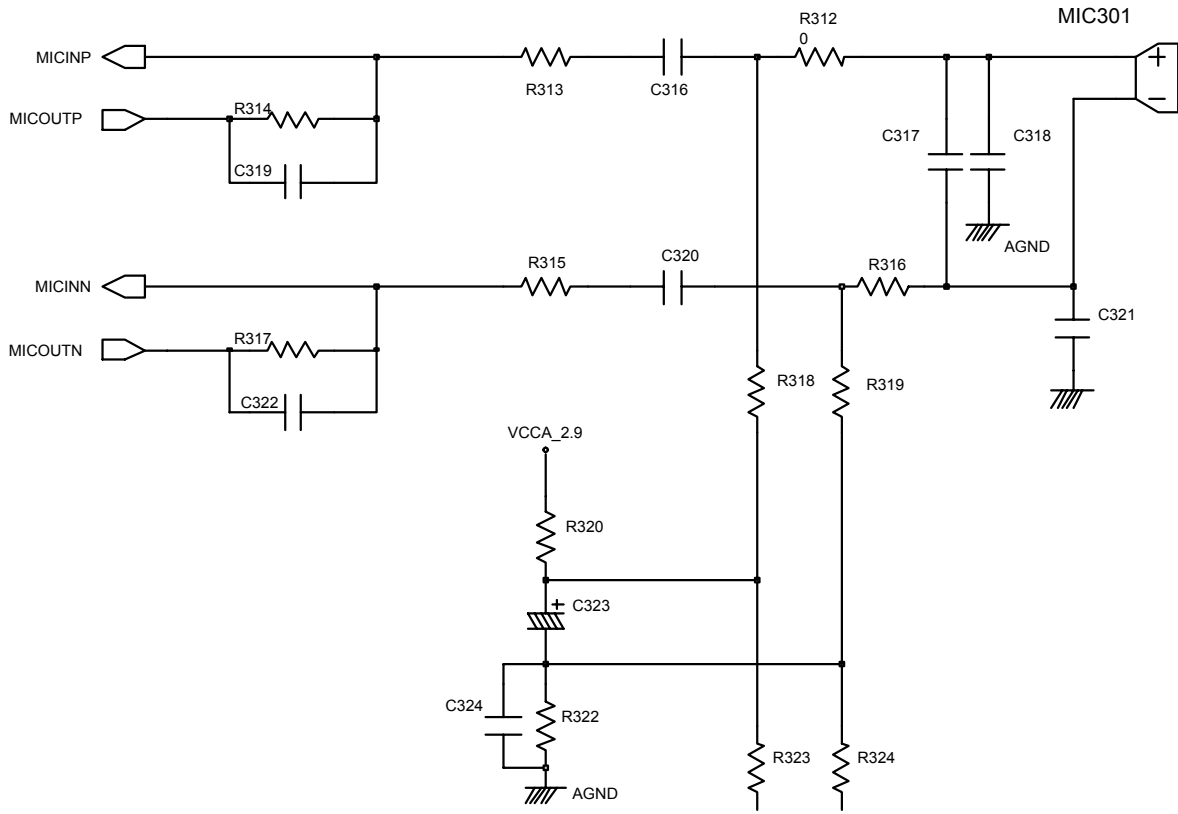

10-1-5. Speaker Part

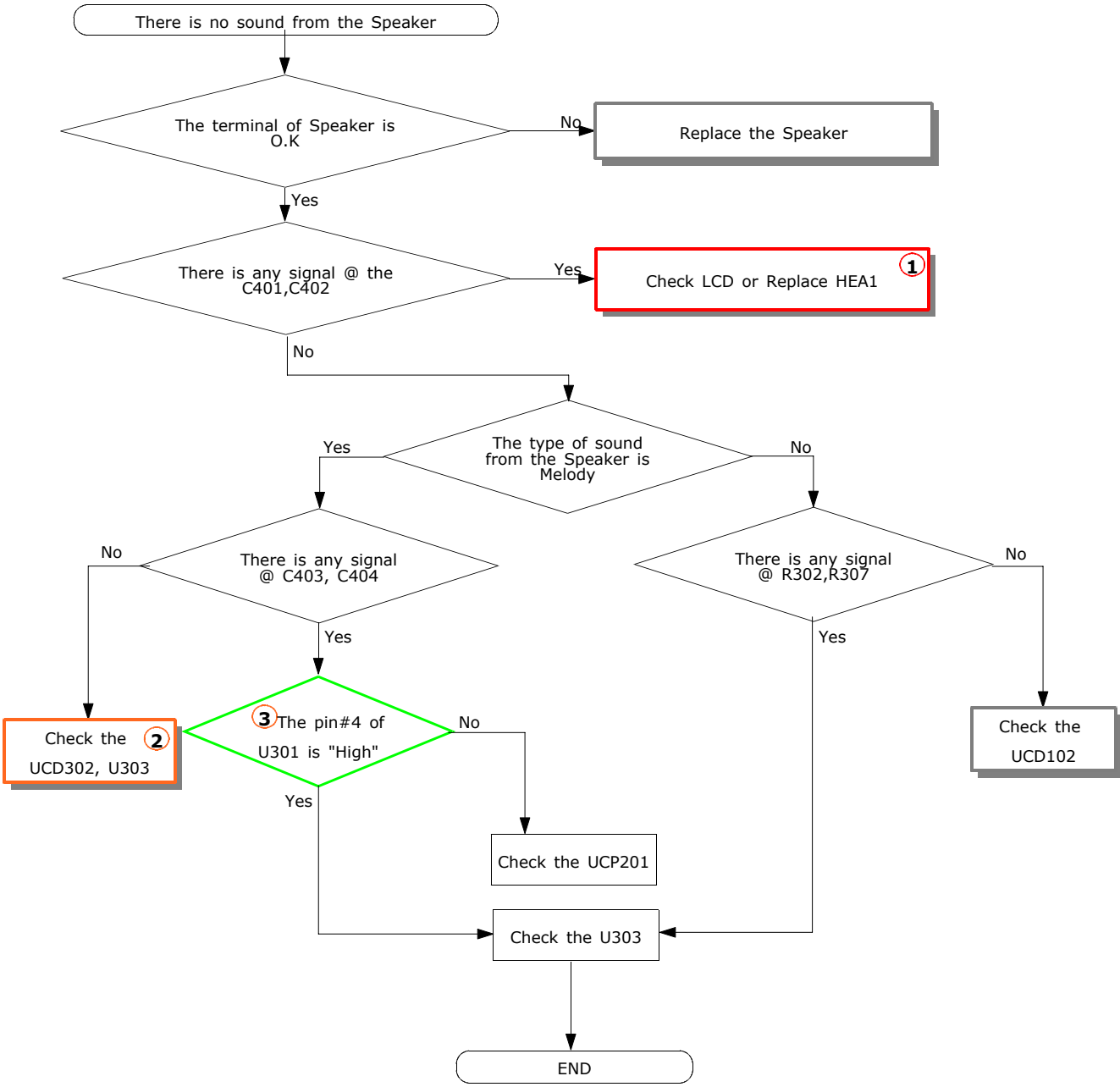

Flow Chart of Troubleshooting

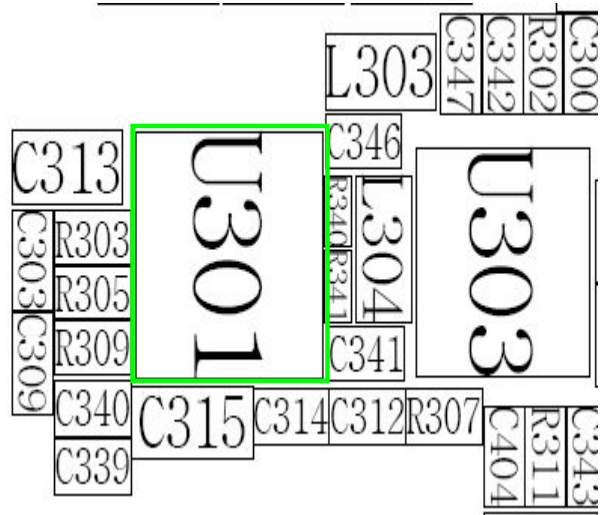
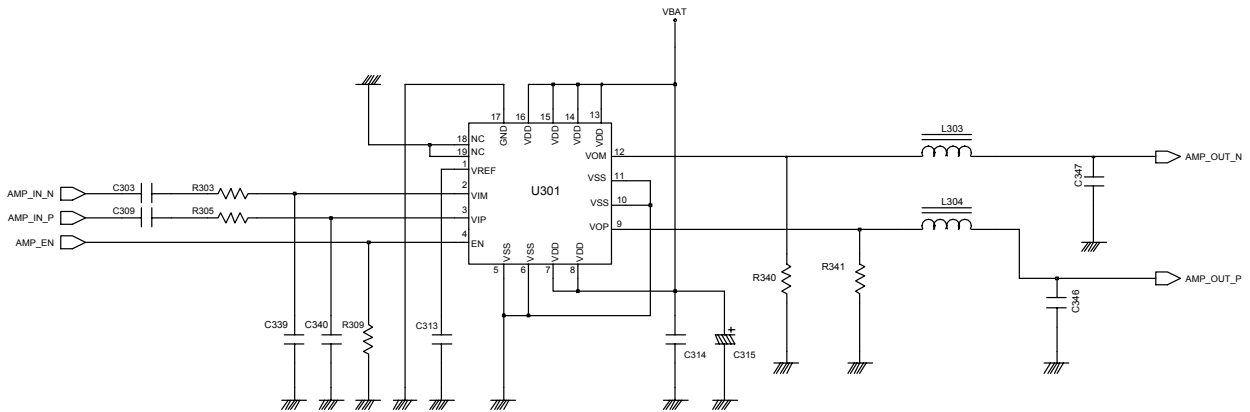
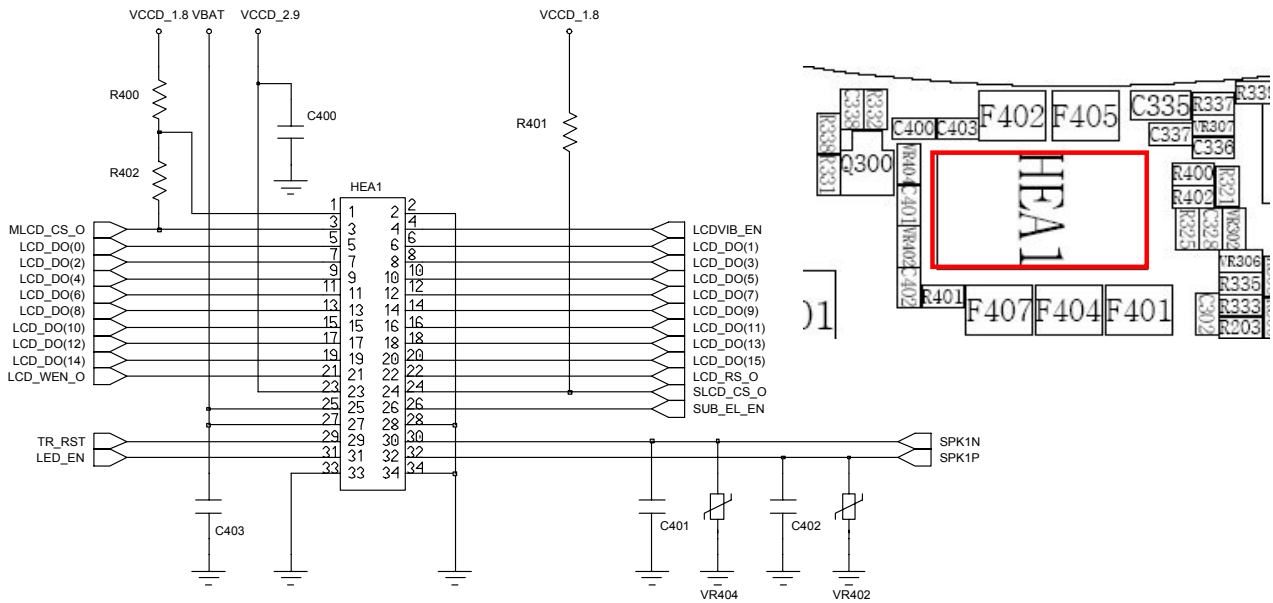

10-2.RF

10-2-1. EGSM RX

CONTINUOUS RX ON
RF INPUT : 62CH
AMP : -50dBm

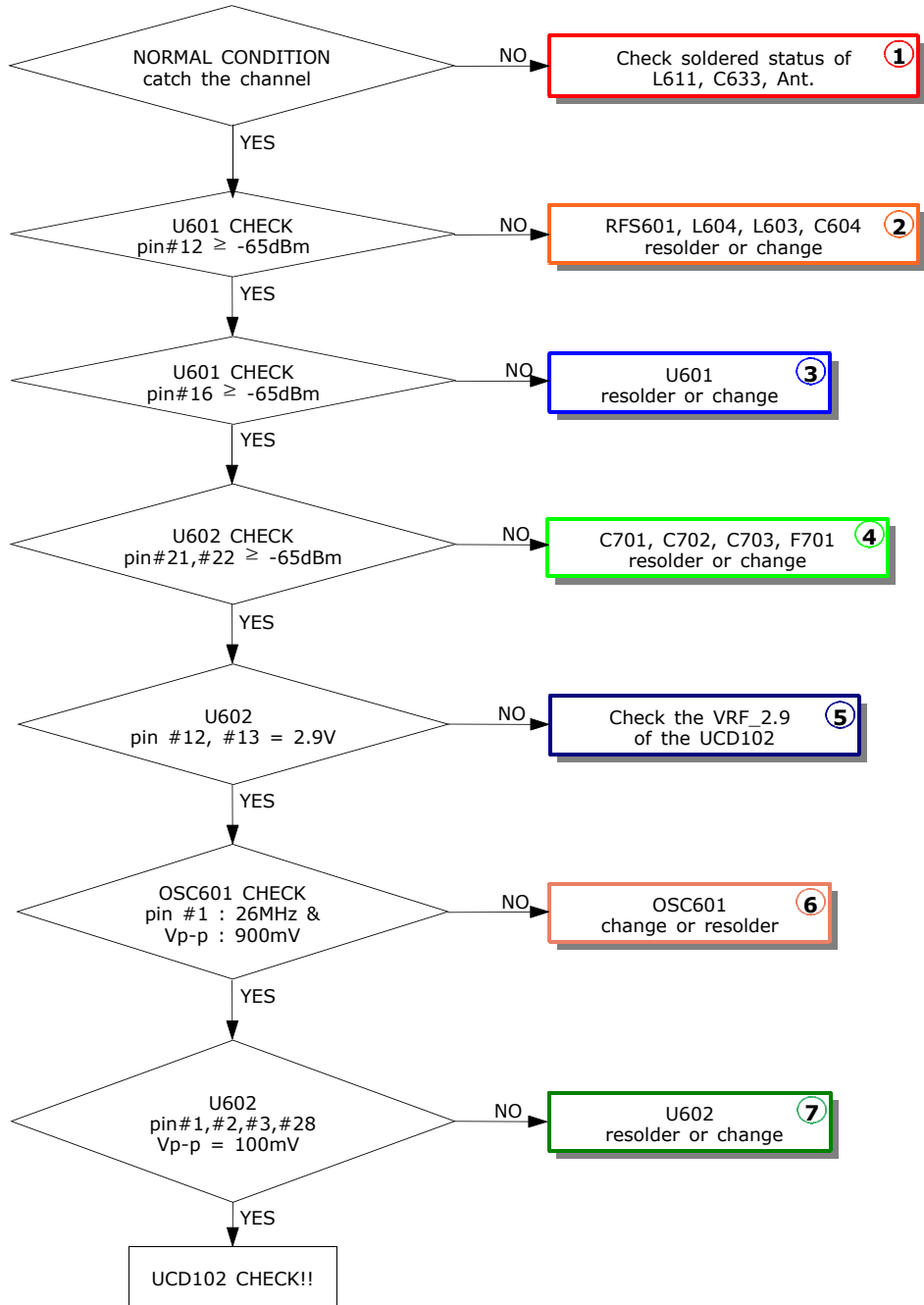

10-2-2. DCS RX

CONTINUOUS RX ON
RF INPUT : 660CH
AMP : -50dBm

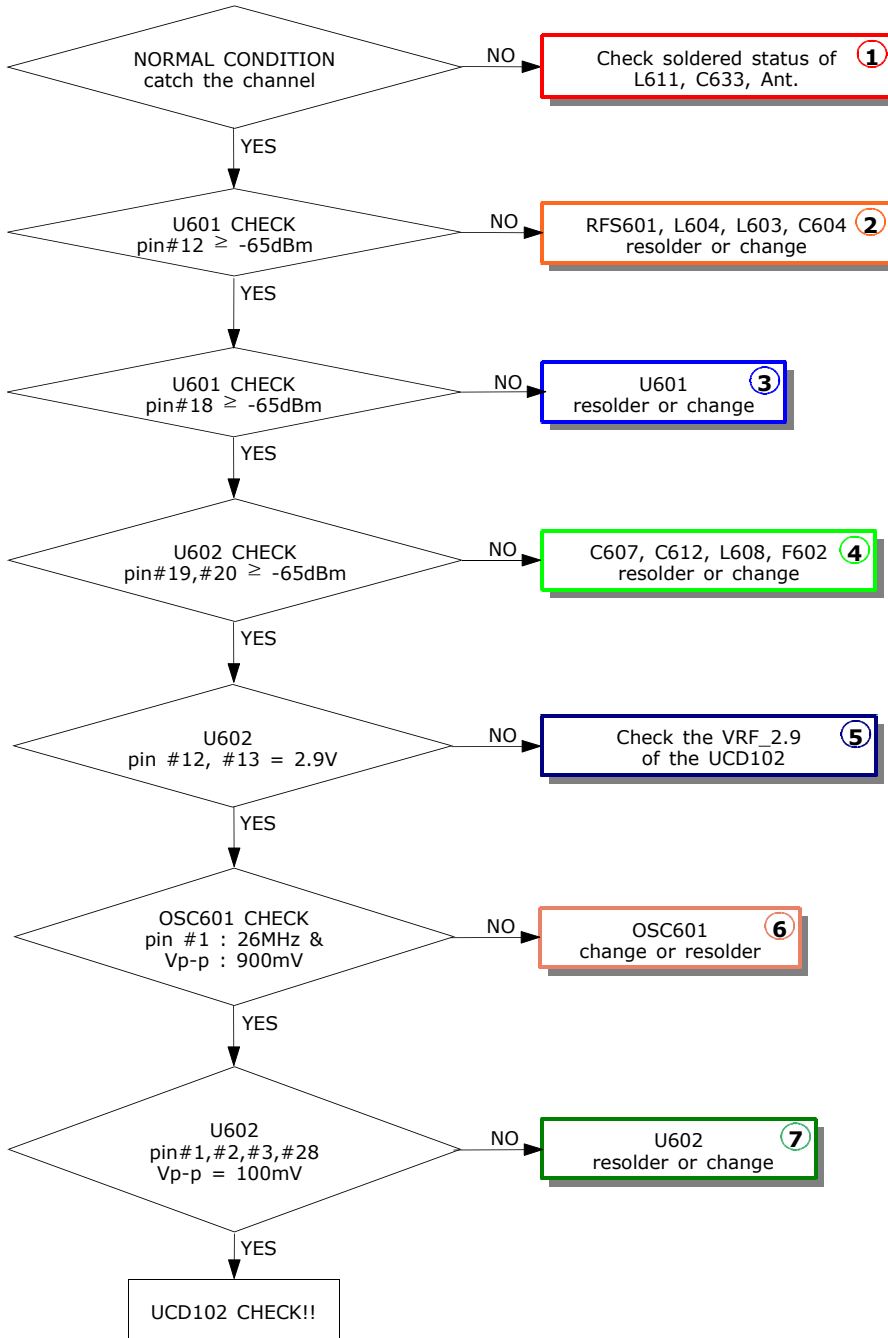

10-2-3. PCS RX

CONTINUOUS RX ON
RF INPUT : 660CH
AMP : -50dBm

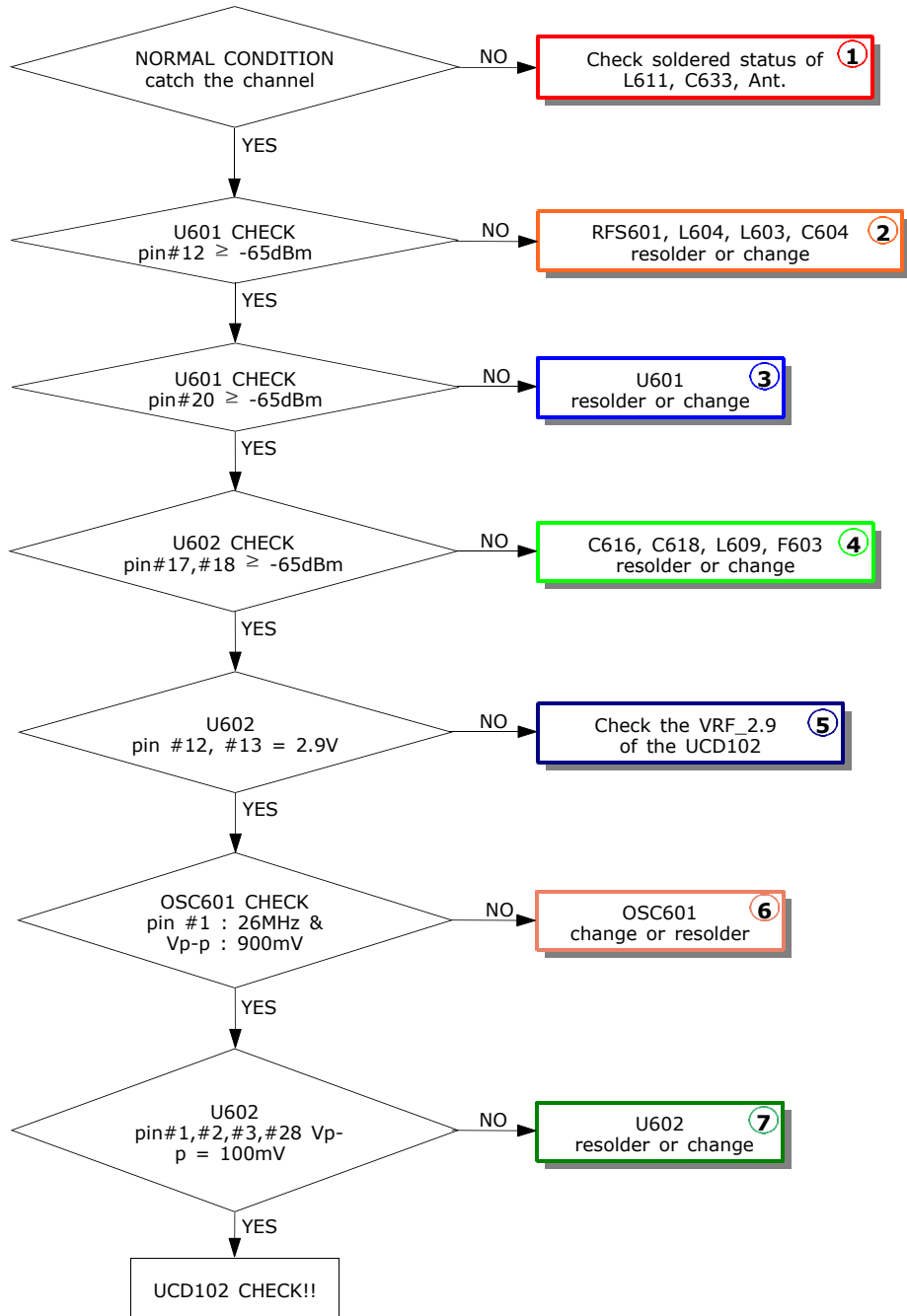

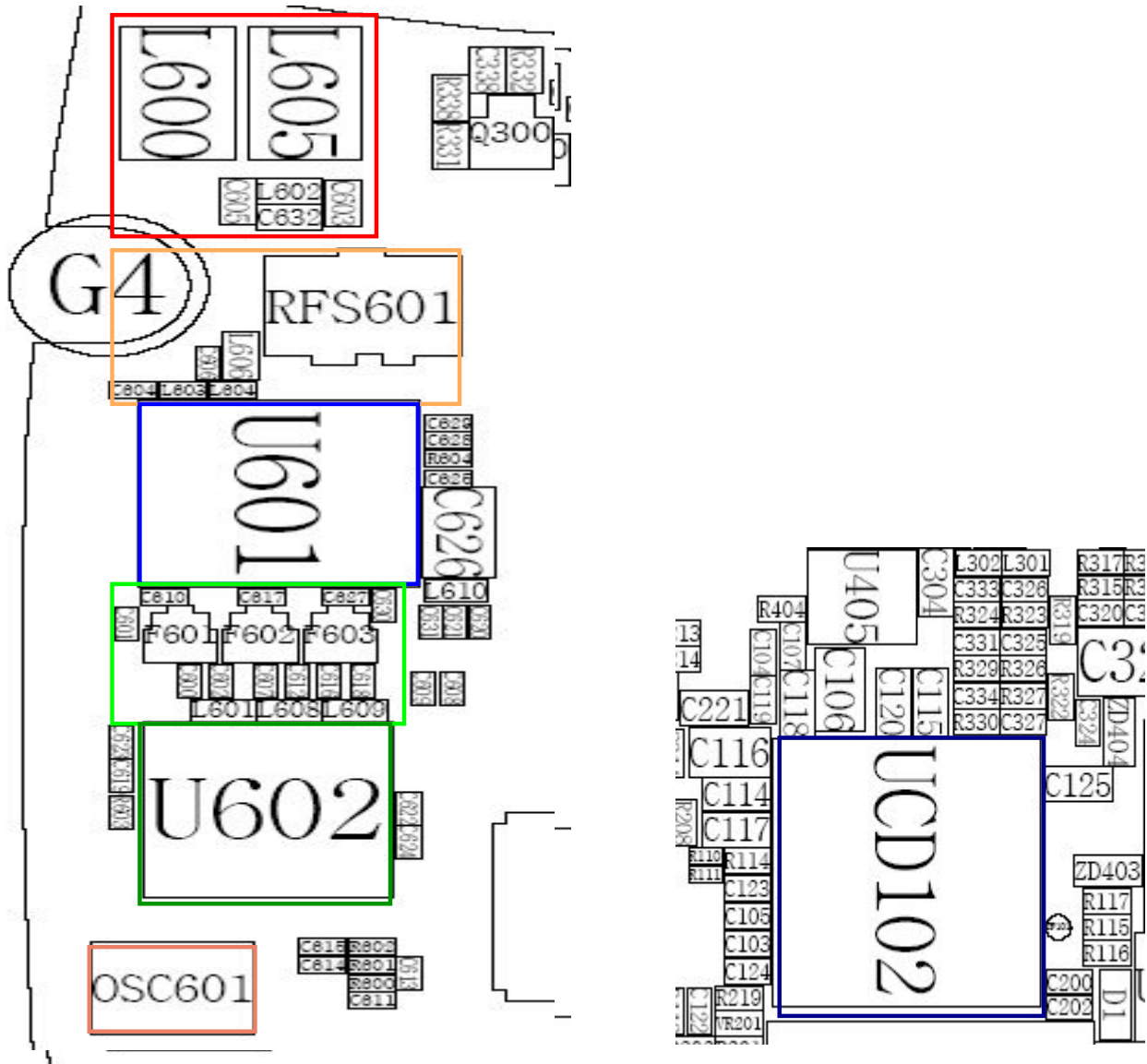

10-2-4. EGSM TX

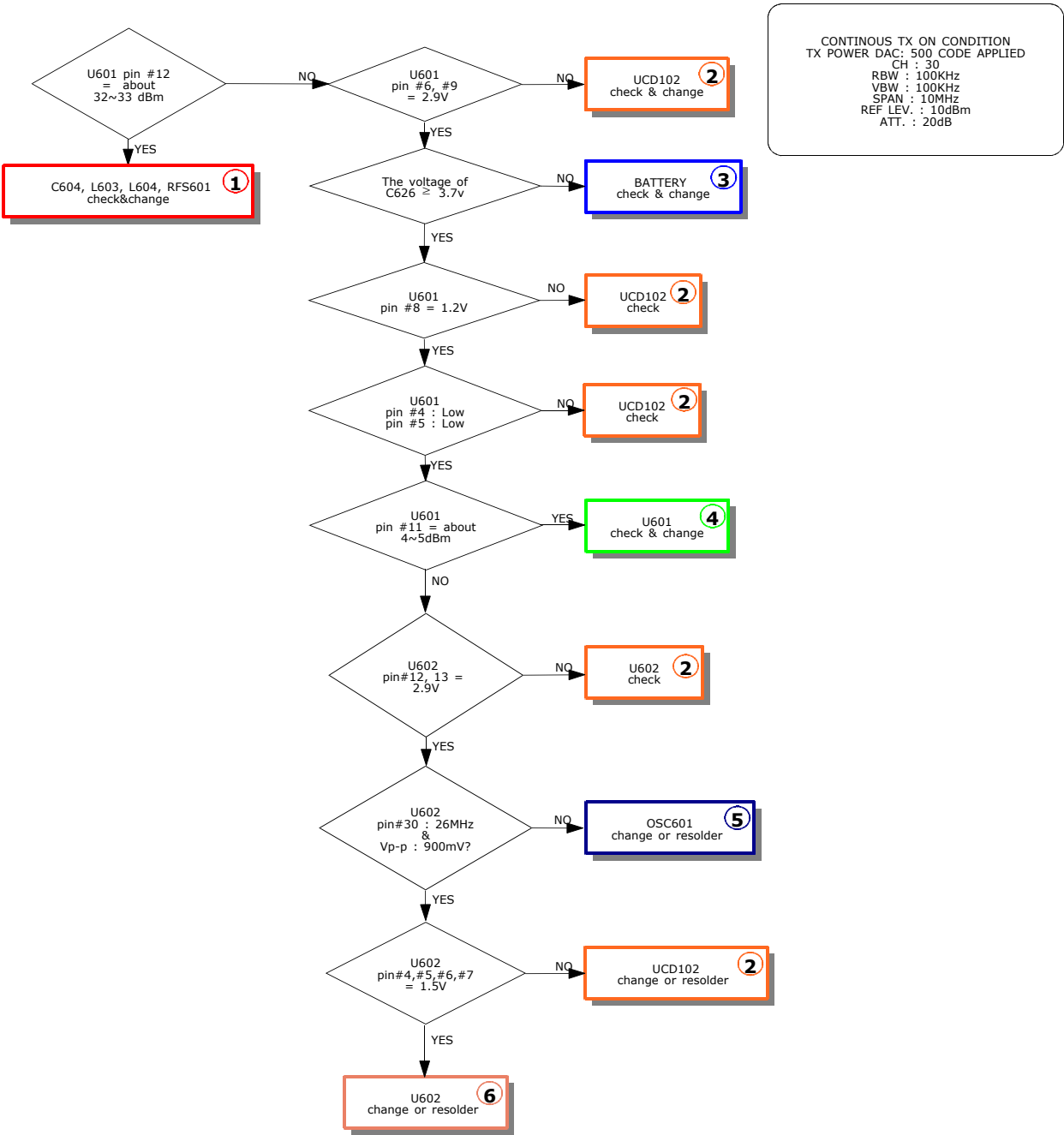

10-2-5. DCS/PCS TX

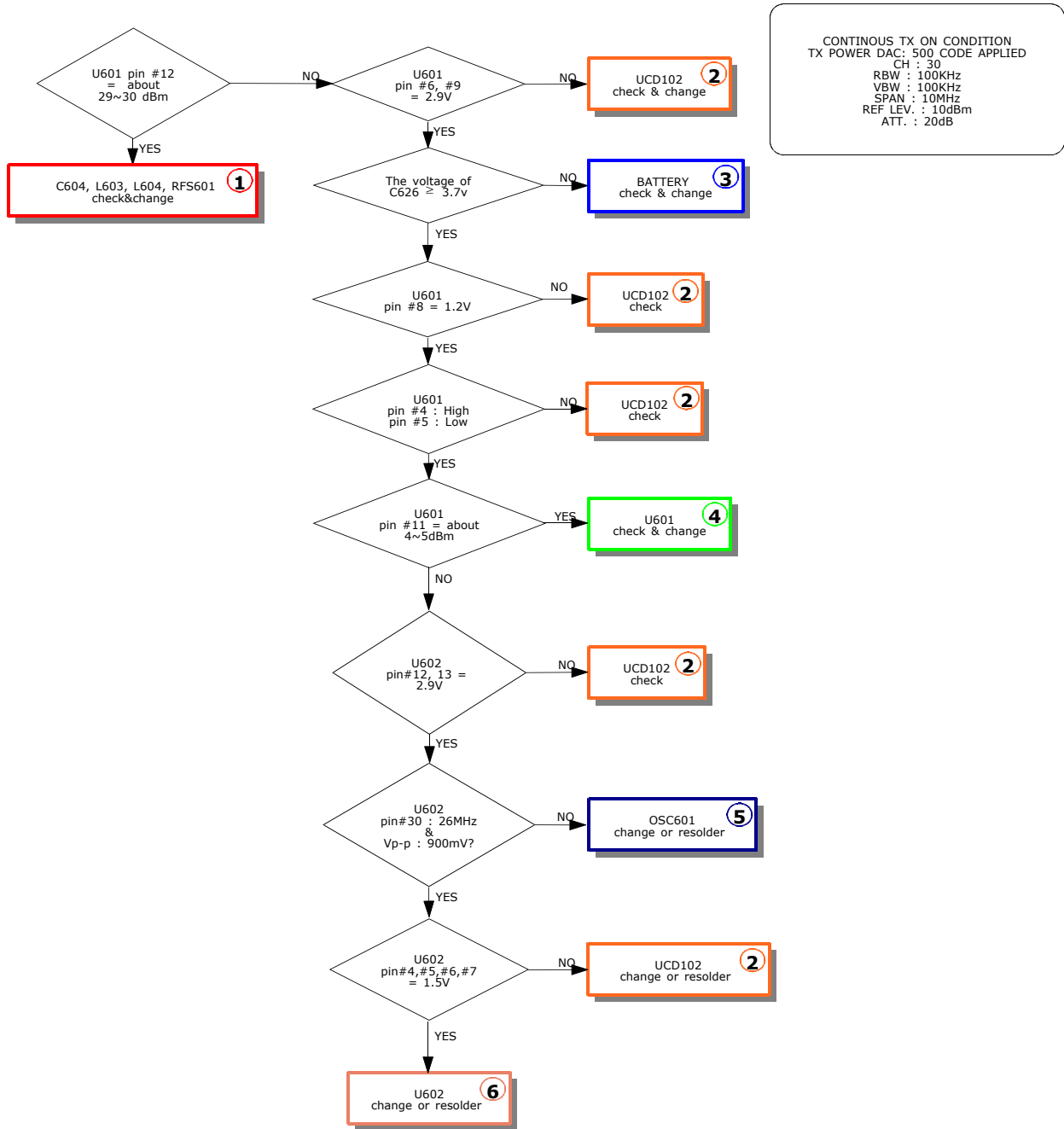

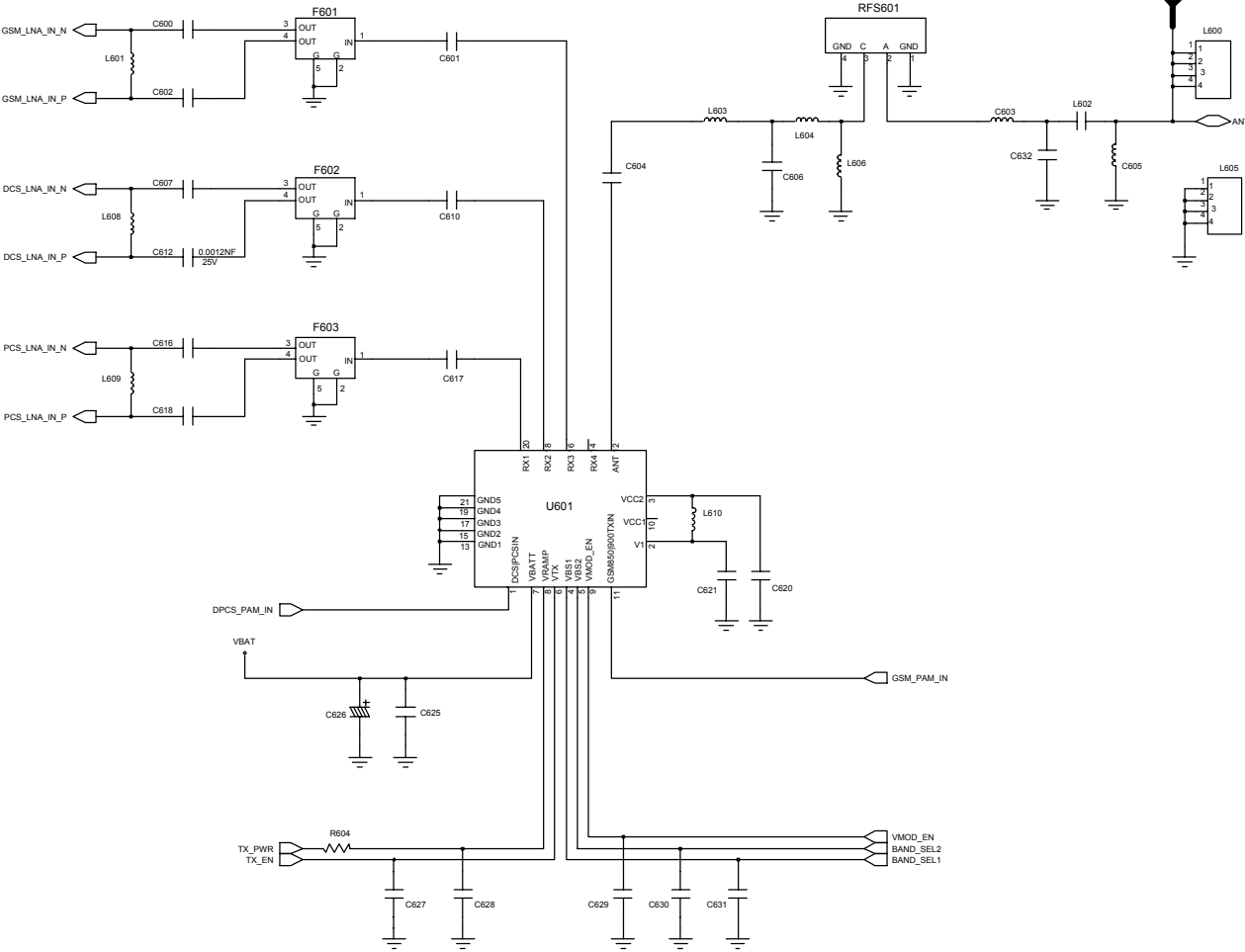

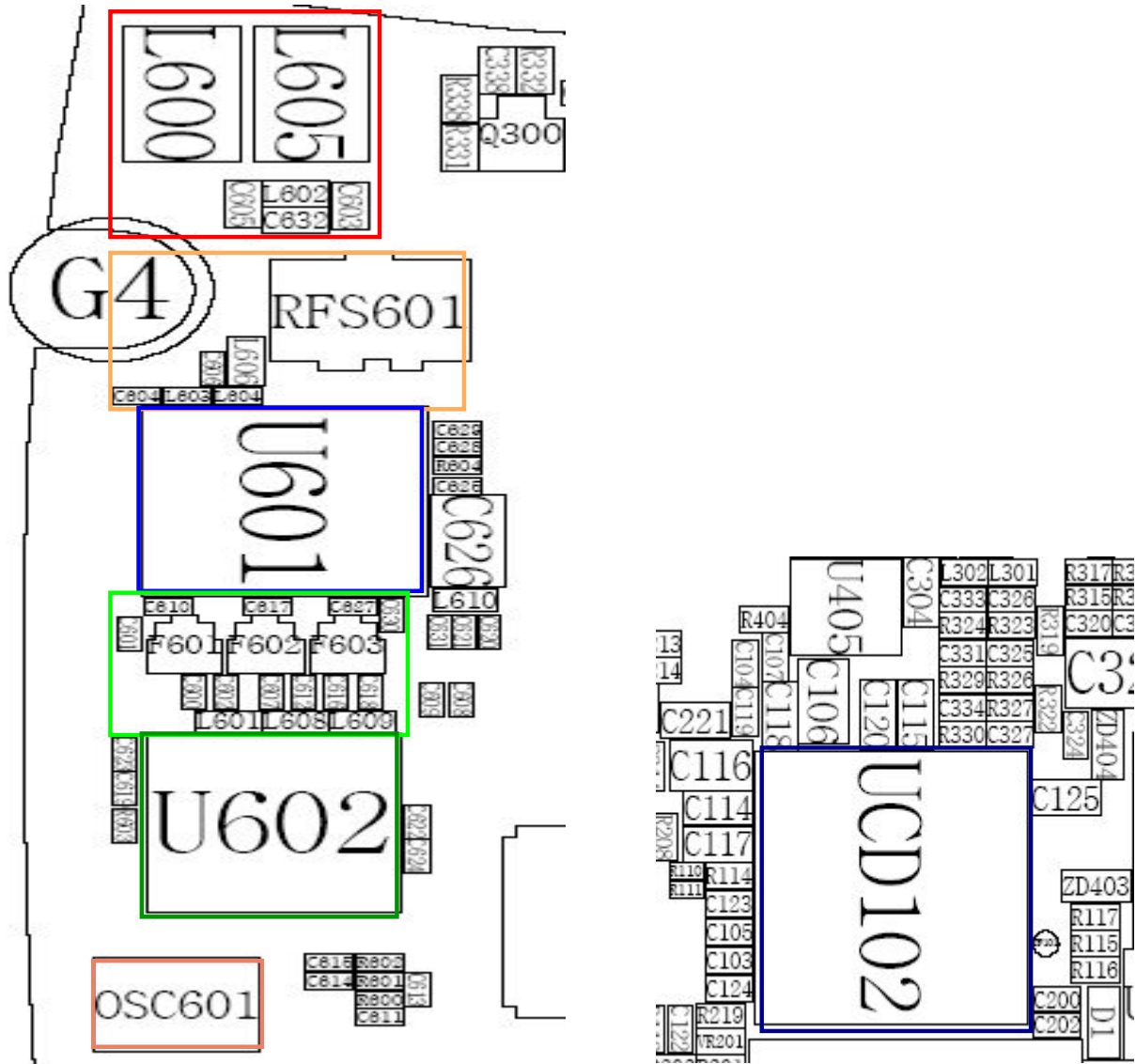

11. Reference data

11-1. Reference Abbreviate

AAC: Advanced Audio Coding.

AVC : Advanced Video Coding.

BER : Bit Error Rate

BPSK: Binary Phase Shift Keying

CA : Conditional Access

CDM : Code Division Multiplexing

C/I : Carrier to Interference

DMB : Digital Multimedia Broadcasting

EN : European Standard

ES : Elementary Stream

ETSI: European Telecommunications Standards Institute

MPEG: Moving Picture Experts Group

PN : Pseudo-random Noise

PS : Pilot Symbol

QPSK: Quadrature Phase Shift Keying

RS : Reed-Solomon

SI : Service Information

TDM : Time Division Multiplexing

TS : Transport Stream

**SAMSUNG
ELECTRONICS**

