

SAMSUNG

GSM TELEPHONE
SGH-X460

SERVICE *Manual*

GSM TELEPHONE

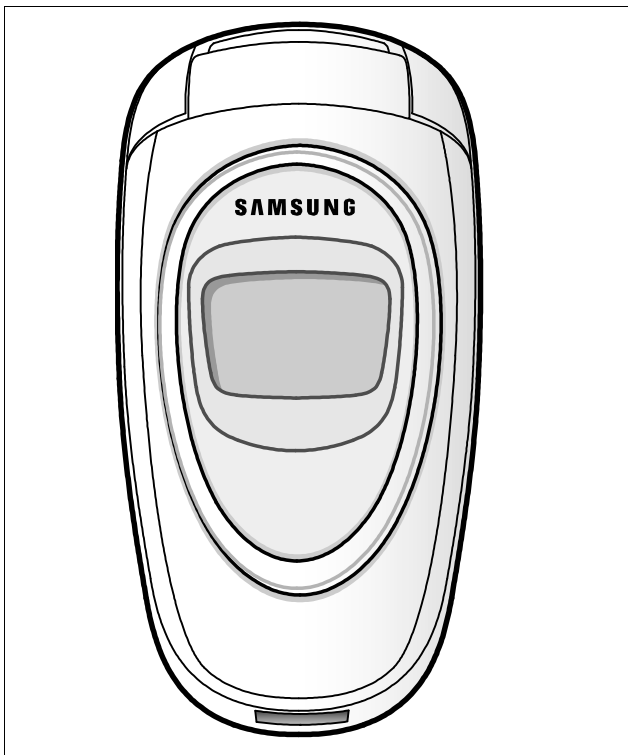

CONTENTS

1. Specification
2. Circuit Description
3. Exploded Views and Parts List
4. Electrical Parts List
5. Block Diagrams
6. PCB Diagrams
7. Flow Chart of Troubleshooting

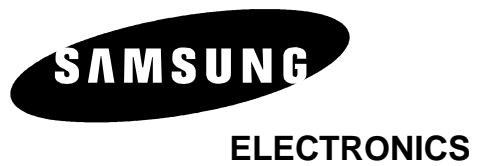

This Service Manual is a property of Samsung Electronics Co.,Ltd.
Any unauthorized use of Manual can be punished under applicable
international and/or domestic law.

Samsung Electronics Co.,Ltd. May. 2004
Printed in Korea.

Code No.: GH68-05344A
BASIC.

1. SGH-X460 Specification

1. GSM General Specification

	GSM900 Phase 1	EGSM 900 Phase 2	DCS1800 Phase 1
Freq. Band[MHz] Uplink/Downlink	890~915 935~960	880~915 925~960	1710~1785 1805~1880
ARFCN range	1~124	0~124 & 975~1023	512~885
Tx/Rx spacing	45MHz	45MHz	95MHz
Mod. Bit rate/ Bit Period	270.833kbps 3.692us	270.833kbps 3.692us	270.833kbps 3.692us
Time Slot Period/Frame Period	576.9us 4.615ms	576.9us 4.615ms	576.9us 4.615ms
Modulation	0.3GMSK	0.3GMSK	0.3GMSK
MS Power	33dBm~13dBm	33dBm~5dBm	30dBm~0dBm
Power Class	5pcl ~ 15pcl	5pcl ~ 19pcl	0pcl ~ 15pcl
Sensitivity	-102dBm	-102dBm	-100dBm
TDMA Mux	8	8	8
Cell Radius	35Km	35Km	2Km

2. GSM TX power class

TX Power control level	GSM900
5	33 ±2 dBm
6	31 ±2 dBm
7	29 ±2 dBm
8	27 ±2 dBm
9	25 ±2 dBm
10	23 ±2 dBm
11	21 ±2 dBm
12	19 ±2 dBm
13	17 ±2 dBm
14	15 ±2 dBm
15	13 ±2 dBm
16	11 ±3 dBm
17	9 ±3dBm
18	7 ±3 dBm
19	5 ±3 dBm

TX Power control level	DCS1800
0	30 ±3 dBm
1	28 ±3 dBm
2	26 ±3 dBm
3	24 ±3 dBm
4	22 ±3 dBm
5	20 ±3 dBm
6	18 ±3 dBm
7	16 ±3 dBm
8	14 ±3 dBm
9	12 ±4 dBm
10	10 ±4 dBm
11	8 ±4dBm
12	6 ±4 dBm
13	4 ±4 dBm
14	2 ±5 dBm
15	0 ±5 dBm

2. SGH-X460 Circuit Description

. SGH-X460 RF Circuit Description

A. RX PART

1. ASM(U102)

Switching Tx, Rx path for GSM900, DCS1800 by logic controlling.

2. ASM Control Logic

Truth Table

	VC_1	VC_2
GSM Tx Mode	H	L
DCS Tx Mode	L	H
GSM Rx Mode	L	L
DCS Rx Mode	L	L

3. FILTER

To convert Electromagnetic Field Wave to Acoustic Wave and then pass the specific frequency band.

- GSM FILTER (F100) For filtering the frequency band between 925 ~ 960 MHz
- DCS FILTER (F101) For filtering the frequency band 1805 and 1880 MHz.

4. VC-TCXO (OSC101)

To generate the 26MHz reference clock to drive the logic and RF.

After additional process, the reference clock applies to the U100 Rx IQ demodulator and Tx IQ modulator.

The oscillator for RX IQ demodulator and Tx modulator are controlled by serial data to select channel and use fast lock mode for GPRS high class operation.

5. UAA3536(U100)

This chip integrates two differential-input LNAs.

The GSM input supports the E-GSM, DCS input supports the DCS1800. The LNA inputs are matched to the 150 ohm differential output SAW filters through external LC matching network.

Image-reject mixer downconverts the RF signal to a 100 KHz intermediate frequency(IF) with the RFLO from OSC100 voltage-controlled oscillator. The RFLO frequency is between 1801 ~ 1921 MHz.

The Mixer output is amplified with an analog programmable gain amplifier(PGA), which is controlled by AGAIN.

The quadrature IF signal is digitized with high resolution A/D converts (ADC).

B. TX PART

Baseband IQ signal fed into offset PLL, this function is included inside of U100 chip.

UAA3536 chip generates modulator signal which power level is about 1.5dBm and fed into Power Amplifier(U105).

The PA output power and power ramping are well controlled by Auto Power Control circuit.

We use offset PLL below table.

Modulation Spectrum	200kHz offset 30 kHz bandwidth	GSM	-35dBc
		DCS	-35dBc
	400kHz offset 30 kHz bandwidth	GSM	-66dBc
		DCS	-65dBc
	600kHz ~ 1.8MHz offset 30 kHz bandwidth	GSM	-75dBc
		DCS	-68dBc

. Baseband Circuit description of SGH-X460

A. PCF50601

1. Power Management

Ten low-dropout regulators designed specifically for GSM applications power the terminal and help ensure optimal system performance and long battery life. A programmable boost converter provides support for 1.8V, 3.0V, and 5.0V SIMs, while a self-resetting, electronically fused switch supplies power to external accessories. Ancillary support functions, such as RTC module and High Voltage Charge pump, Clock generator, aid in reducing both board area and system complexity.

I2C BUS serial interface provides access to control and configuration registers. This interface gives a microprocessor full control of the PCF50601 and enables system designers to maximize both standby and talk times.

Supervisory functions, including a reset generator, an input voltage monitor, and a temperature sensor, support reliable system design. These functions work together to ensure proper system behavior during start-up or in the event of a fault condition(low microprocessor voltage, insufficient battery energy, or excessive die temperature).

2. Backlight Brightness Modulator

The Backlight Brightness Modulator (BBM) contains a programmable Pulse-width modulator (PWM) and FET to modulate the intensity of a series of LED's or to control a DC/DC converter that drives LCD backlight.

This phone (SGH-X460) use PWM.

3. Clock Generator

The Clock Generator (CG) generates all clocks for internal and external usage. The 32768 Hz crystal oscillator provides an accurate low clock frequency for the PCF50601 and other circuitry.

B. Connector

1. LCD Connector

LCD is consisted of main LCD(color 65K UFB LCD) and small LCD(B/W). Chip select signals, LCD_MAIN_CS and LCD_SUB_CS, can enable Each LCD. Backlight signal enables white LED of main LCD and small LCD. "RESET_2V8" signal initiates the Reset process of the LCD.

16-bit data lines(HD(0)~HD(15)) transfers data and commands to LCD through by pass capacitor.

"SPK_P" and "SPK_N" from OM6357 are used for audio speaker. And "VDD_VIB" from PCF50601 enables the motor.

2. Key

This is consisted of key interface pins among OM6357, KBIO(0:7). These signals compose the matrix. Result of matrix informs the key status to key interface in the OM6357. Power on/off key is separated from the matrix. So power on/off signal is connected with PCF50601 to enable PCF50601. twelve key LED use the "VBAT" supply voltage. "VDD_KEY" signal enables LEDs with current control. "FLIP" informs the status of folder (open or closed) to the OM6357. This uses the hall effect IC, A3210ELH. A magnet under main LCD enables A3210ELH.

3. EMI ESD Filter

This system uses the EMI ESD filter, EMIF09 to protect noise from IF CONNECTOR part.

4. IF connetor

It is 24-pin connector. They are designed to use VBAT, V_EXT_CHARGE, TXD0, RXD0, RTS0, CTS0, JIG_REC, CHARGER_OK, RXD1, TXD1, AUX_MIC, AUX_SPK and GND. They connected to power supply IC, microprocessor and signal processor IC.

C. Battery Charge Management

A complete constant-current/constant-voltage linear charger for single cell lithium-ion batteries.

If TA connected to phone, "CHARGER_OK" enable charger IC and supply current to battery. when fault condition caused, "CHG_ON" signal level change low to high and charger IC stop charging process.

D. Audio

EARP_P and EARP_N from OM6357 are connected to the main speaker. AUXSP is connected to the Hands free kit. MIC_P and MIC_N are connected to the main MIC. And AUX_MIC_P and AUX_MIC_N are connected to the Hands free kit.

YMU762C is a LSI for portable telephone that is capable of playing high quality music by utilizing FM synthesizer and ADPCM decoder that are included in this device.

As a synthesis, YMU762MA3 is equipped 32 voices with different tones. Since the device is capable of simultaneously generating up to synchronous with the play of the FM synthesizer, various sampled voices can be used as sound effects.

Since the play data of YMU762MA3 are interpreted at anytime through FIFO, the length of the data(playing period) is not limited, so the device can flexibly support application such as incoming call melody music distribution service. The hardware sequencer built in this device allows playing of the complex music without giving excessive load to the CPU of the portable telephones. Moreover, the registers of the FM synthesizer can be operated directly for real time sound generation, allowing, for example, utilization of various sound effects when using the game software installed in the portable telephone.

YMU762 includes a speaker amplifier with high ripple removal rate whose maximum output is 550mW (SPVDD=3.6V). The device is also equipped with conventional function including a vibrator synchronous with music.

For the headphone, it is provided with a stereophonic output terminal.

For the purpose of enabling YMU762MA3 to demonstrate its full capabilities, Yamaha purpose to use "SMAF:Synthetic music Mobile Application Format" as a data distribution format that is compatible with multimedia.

Since the SMAF takes a structure that sets importance on the synchronization between sound and images, various contents can be written into it including incoming call melody with words that can be used for training karaoke, and commercial channel that combines texts, images and sounds, and others.

The hardware sequencer of YMU762MA3 directly interprets and plays blocks relevant to synthesis (playing music and reproducing ADPCM with FM synthesizer) that are included in data distributed in SMAF.

E. Memory

Signals in the OM6357 enable two memories. They use only one volt supply voltage, VDD3 in the PCF50601. This system uses Samsung's memory, KBB06A300M-T402. It is consisted of 128M bits flash NOR memory and 128M bits flash NAND memory and 32M bits UtRAM. It has 16 bit data line, HD[0~15] which is connected to OM6357. It has 23 bit address lines, HA[1~23]. CS_NAND and NCSRAM signals is chip select.

Writing process, HWR_N is low and it enables writing process to flash memory and SRAM. During reading process, HRD_N is low and it enables reading process to flash memory and SRAM. Each chip select signals in the OM6357 select memory among 2 flash memory and UtRAM.

Reading or writing procedure is processed after HWR_N or HRD_N is enabled. Memories use reset, which is VDD3 delay from PCF50601. HA[22] signal enables lower byte of SRAM and HA[22] signal enables higher byte of SRAM.

F. OM6357

OM6357 is consisted of ARM core and DSP core. It has 8x1Kword on-chip program/data RAM, 55 Kwords on-chip program ROM in the DSP. It has 4K*32bits ROM and 2K*32bits RAM in the ARM core. DSP is consisted of KBS, JTAG, EMI and UART. ARM core is consisted of EMI, PIC(Programmable Interrupt Controller), reset/power/clock unit, DMA controller, TIC(Test Interface Controller), eripheral bridge, PPI, SSI(Synchronous Serial Interface), ACC(Asynchronous communications controllers), timer, ADC, RTC(Real-Time Clock) and keyboard interface.

KBIO(0:7), address lines of DSP core and HD[0~15]. HA[1~23], address lines of ARM core and HD[0~15], data lines of ARM core are connected to memory, YMU762. MV317S(Camera DSP Chip) controls the communication between ARM core and DSP core.

CS_NAND, NCSRAM, NCSFLASH in the ARM core are connected to each memory. HWR_N and HRD_N control the process of memory. External IRQ(Interrupt Request) signals from each units, such as, PMU need the compatible process.

KBIO[0~7] receive the status from key and RXD0/TXD0/IrDA_DOWN are used for the communications using IRDA and data link cable(DEBUG_DTR/RTS/TXD/RXD/CTS/DSR).

It has JTAG control pins(TDI/TDO/TCK) for ARM core and DSP core. It receives 13MHz clock in CKI pin from external TCXO. ADC(Analog to Digital Convertor) part receives the status of temperature, battery type and battery voltage.

G. VC_TCXO-214C6(26MHz)

This system uses the 26MHz TCXO, VC_TCXO-214C6. AFC control signal from OM6357 controls frequency from 26MHz X-tal. The clock output frequency of UAA3536HN is 13MHz. This clock is connected to OM6357, YMU762.

3. SGH-X460 Exploded View and its Parts list

1. Cellular phone Exploded View-1

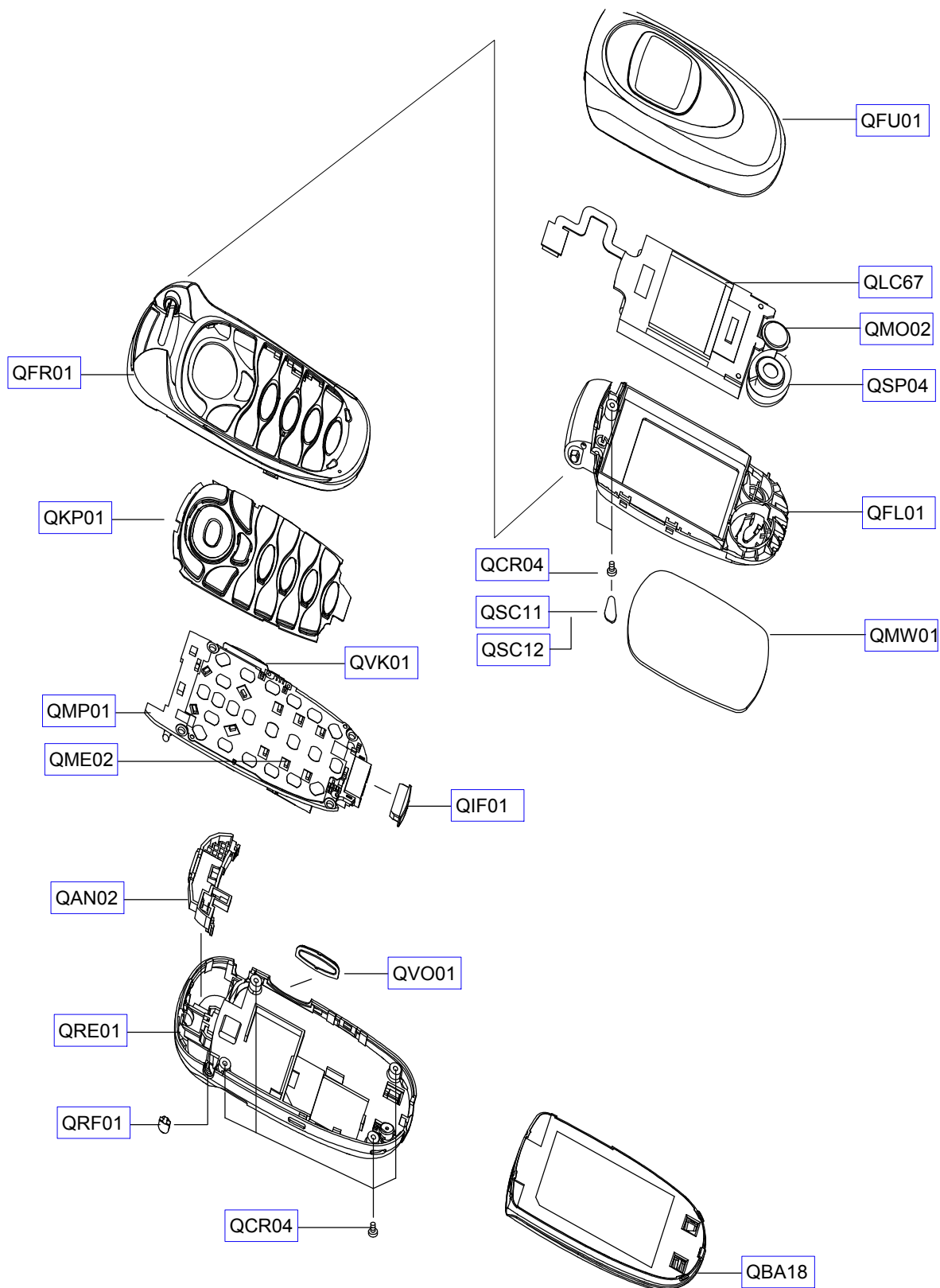

2. Cellular phone Parts list

Location NO.	Description	SEC CODE	Remark
QFU01	FOLDER UPPER	GH75-04524A	
QLC67	LCD	GH07-00564A	
QSP04	SPEAKER	3001-001574	
QMO02	MOTOR	3101-001315	
QFL01	FOLDER LOWER	GH75-04525A	
QMW01	MAIN WINDOW LCD	GH75-04528A	
QFR01	FRONT COVER	GH75-04523A	
QVO01	VOLUME KEY	GH75-04529A	
QKP01	KEYPAD	GH75-04527A	
QMP01	MAIN PBA	GH92-01799A	
QVK01	VOL KEY FPCB	GH59-01419A	
QAN02	INTENNA	GH42-00425A	
QME02	METAL DOME	GH59-01418A	
QRE01	REAR COVER	GH75-04526A	
QIF01	IF COVER	GH72-13265A	
QRF01	RF COVER	GH72-15078A	
QCR04	SCREW	6001-001479	
QBA18	BATTERY	GH43-01418A	
QSC11	FOLDER SCREW CAP R	GH74-09038A	
QSC12	FOLDER SCREW CAP L	GH74-09039A	

3. Test Jig (GH80-01909A)



3-1. RF Test Cable
(GH39-00261A)



3-2. Test Cable
(GH39-00217A)



3-3. Serial Cable



3-4. Power Supply Cable



3-5. DATA CABLE
(GH39-00143B)



3-6. TA
(GH44-00482A)



4. SGH-X460 Electrical Parts List

SEC CODE	Design LOC
0403-001427	ZD301
0406-001167	ZD604,ZD605
0406-001201	V501,V502,V601,V602
0406-001201	V603,ZD401,ZD402
0406-001201	ZD501,ZD502,ZD503
0406-001201	ZD504,ZD505,ZD506
0505-001423	U606
0601-001790	LED500,LED501,LED502
0601-001790	LED503,LED504,LED505
0601-001790	LED506,LED507,LED508
0601-001790	LED510,LED511
0801-002237	U301
0801-002882	U202,U303,U602,U603
1001-001253	U502
1009-001010	SW500
1109-001280	U300
1201-002075	U105
1202-001036	U501
1203-003105	U500
1203-003109	U304
1204-002161	U302
1205-002276	U200
1205-002327	U100
1205-002350	U400
1404-001221	V300
1405-001082	V301,V302,V304,V604
1405-001082	V605,V606,V607,V608
1405-001082	V609,V610,V611,V612
1405-001082	V613
2007-000140	R104,R311
2007-000141	R101,R205,R206,R314
2007-000142	R116
2007-000146	R308
2007-000148	R107,R118,R121,R124
2007-000148	R132,R133,R201,R400
2007-000148	R401,R504
2007-000157	R312,R316
2007-000162	R200,R202,R203,R303
2007-000162	R306,R307,R313,R315

SEC CODE	Design LOC
2007-000162	R317,R323,R324,R501
2007-000162	R600,R601
2007-000171	R102,R105,R111,R112
2007-000171	R207,R305,R403,R532
2007-000172	R103
2007-000173	R507,R509,R510,R511
2007-000173	R512,R513,R516,R517
2007-000173	R531
2007-000174	R109
2007-000242	R502,R506
2007-000566	R106,R108,R320
2007-000982	R119,R120,R122,R123
2007-001288	R125,R129
2007-001301	R514,R515
2007-001305	R113,R115
2007-001313	R301
2007-001325	R304
2007-003001	R114
2007-007001	R204
2007-007008	R127,R128,R130,R131
2007-007009	R117
2007-007014	R300,R302
2007-007100	R402
2007-007107	R321,R322
2007-007148	R100
2007-007311	R110,R134
2007-007334	R519
2007-007480	R521,R522
2007-007489	R135,R518
2007-007573	R319
2007-008117	R318
2203-000233	C103,C104,C121,C300
2203-000233	C316
2203-000254	C125,C151,C154,C200
2203-000254	C201,C302,C405
2203-000278	C134,C143,C144,C501
2203-000278	C502,C510,C511,C601
2203-000278	C602,C603
2203-000359	C150,C310

SEC CODE	Design LOC
2203-000425	C102,C109
2203-000438	C123,C153,C305,C313
2203-000550	C127
2203-000585	C126,C130,C131,C132
2203-000585	C133
2203-000609	C128
2203-000679	C303,C432,C604
2203-000800	C117
2203-000812	C137,C142,C145,C156
2203-000812	C202,C207,C320,C321
2203-000812	C431,C528
2203-000854	C100,C107,C129
2203-000940	C149,C152
2203-000995	C529,C530,C607,C608
2203-000995	C609,C610,C611,C612
2203-001153	C138,C146
2203-001652	C410,C422
2203-002443	C503
2203-002525	C110
2203-003054	C407,C409
2203-005054	C430
2203-005056	C141
2203-005057	C114,C120
2203-005065	C122,C420
2203-005138	C108
2203-005288	C139
2203-005382	C155
2203-005481	C116,C118
2203-005482	C105,C106,C113,C115
2203-005482	C119,C203,C204,C205
2203-005482	C206,C208,C209,C210
2203-005482	C211,C212,C213,C214
2203-005482	C215,C216,C217,C218
2203-005482	C219,C220,C301,C304
2203-005482	C306,C309,C312,C319
2203-005482	C401,C403,C404,C408
2203-005482	C414,C417,C428,C504
2203-005482	C505,C509
2203-006053	C124,C308,C421,C424

SEC CODE	Design LOC
2203-006053	C425,C426,C427
2203-006093	C411,C524
2203-006137	C307
2203-006208	C402,C406,C413
2203-006257	C317
2203-006324	C412,C415
2301-001197	C111
2301-001213	C112
2404-001105	C314
2404-001225	C418,C419,C423,C429
2404-001239	C136
2404-001268	C135,C315
2404-001333	C500,C527
2703-001734	L104
2703-002199	L106
2703-002200	L101
2703-002203	L103
2703-002208	L100,L102
2703-002308	L109,L110
2703-002368	L112
2703-002700	L108
2801-004339	X1
2806-001329	OSC100
2809-001287	OSC101
2901-001246	U305
2901-001286	F600,F601,F602,F603
2904-001469	F100
2904-001470	F101
2909-001216	U102
3301-001105	L400,L501,L502
3301-001362	L503
3301-001438	R503,R505
3705-001242	CON101
3709-001298	CN500
3710-002115	CN300
3711-005487	CN600
3722-002067	EAR500
4302-001157	BAT400

2. Base Band Solution Block Diagram

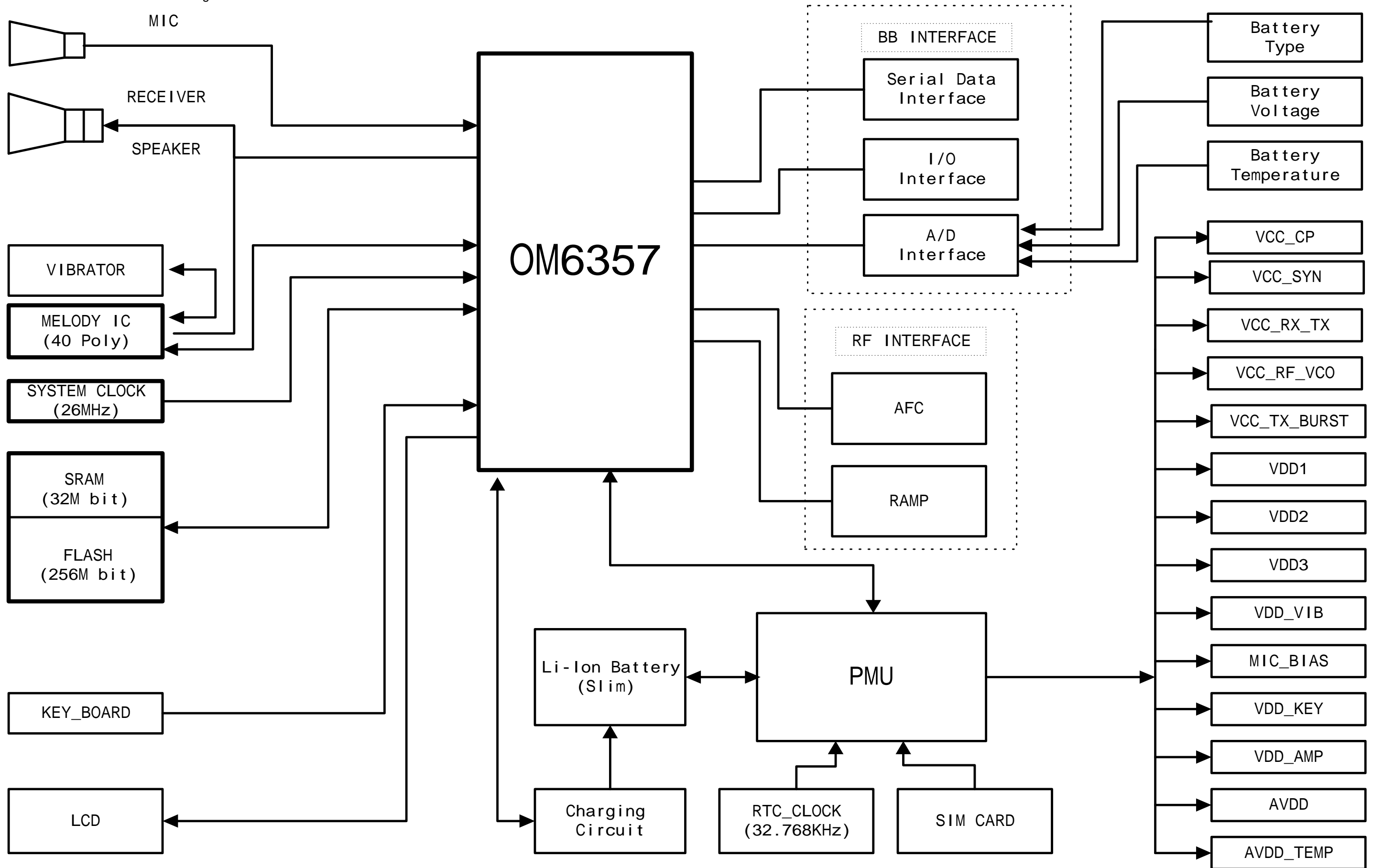

6. SGH-X460 PCB Diagrams

1. Main PCB Top Diagram

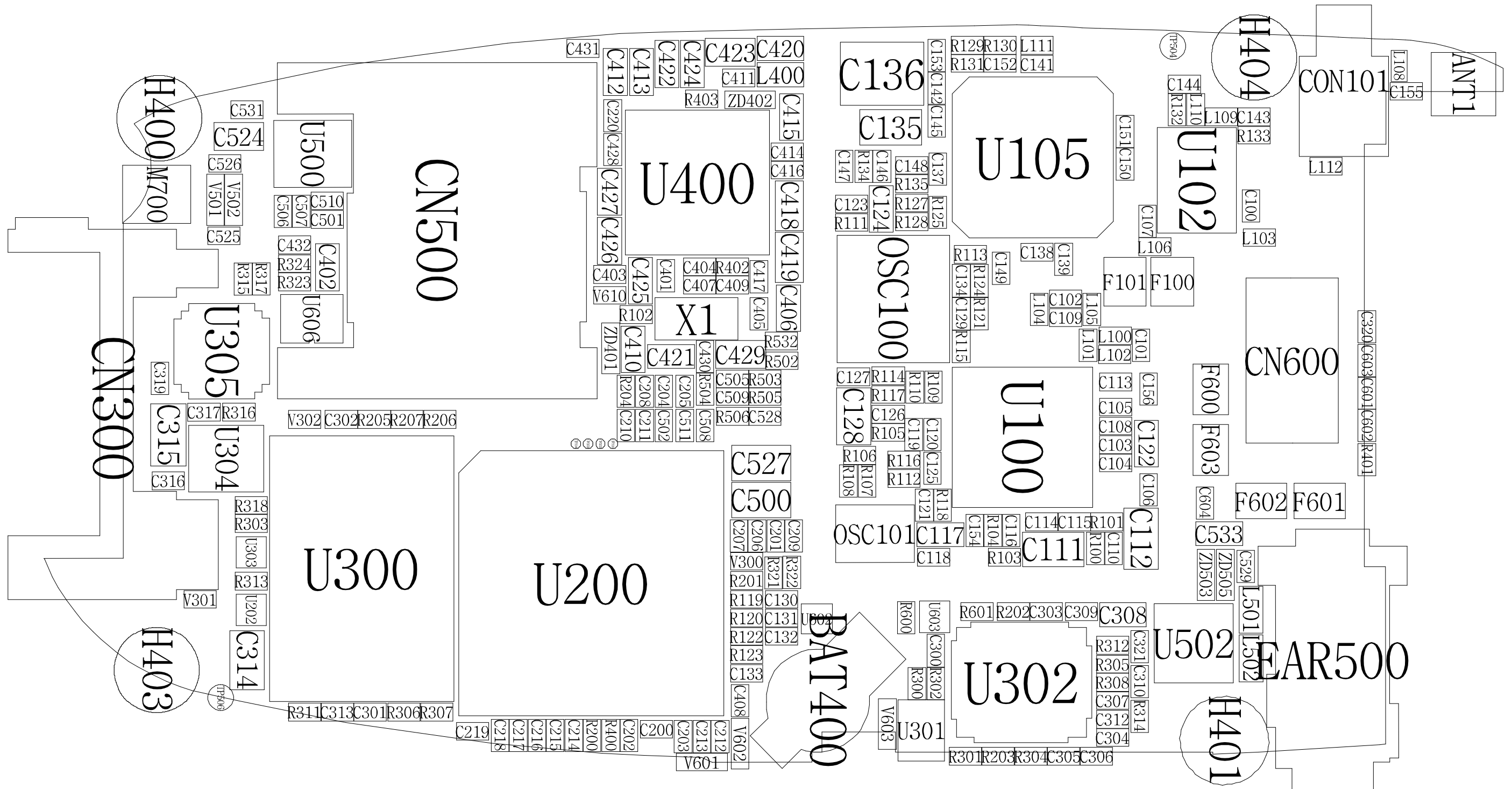

2. Main PCB Bottom Diagram

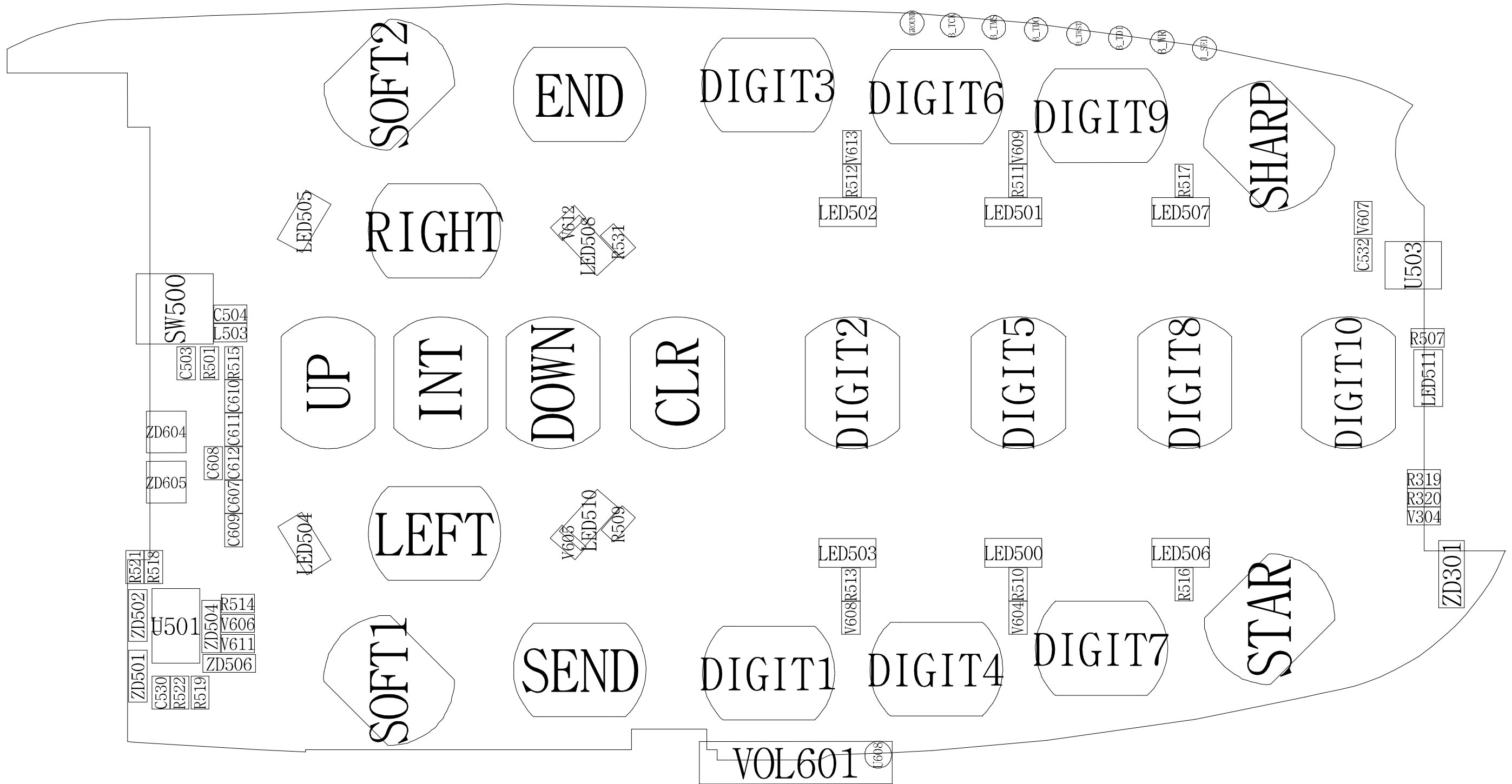

7. SGH-X460 Flow Chart of Troubleshooting

1. Power On

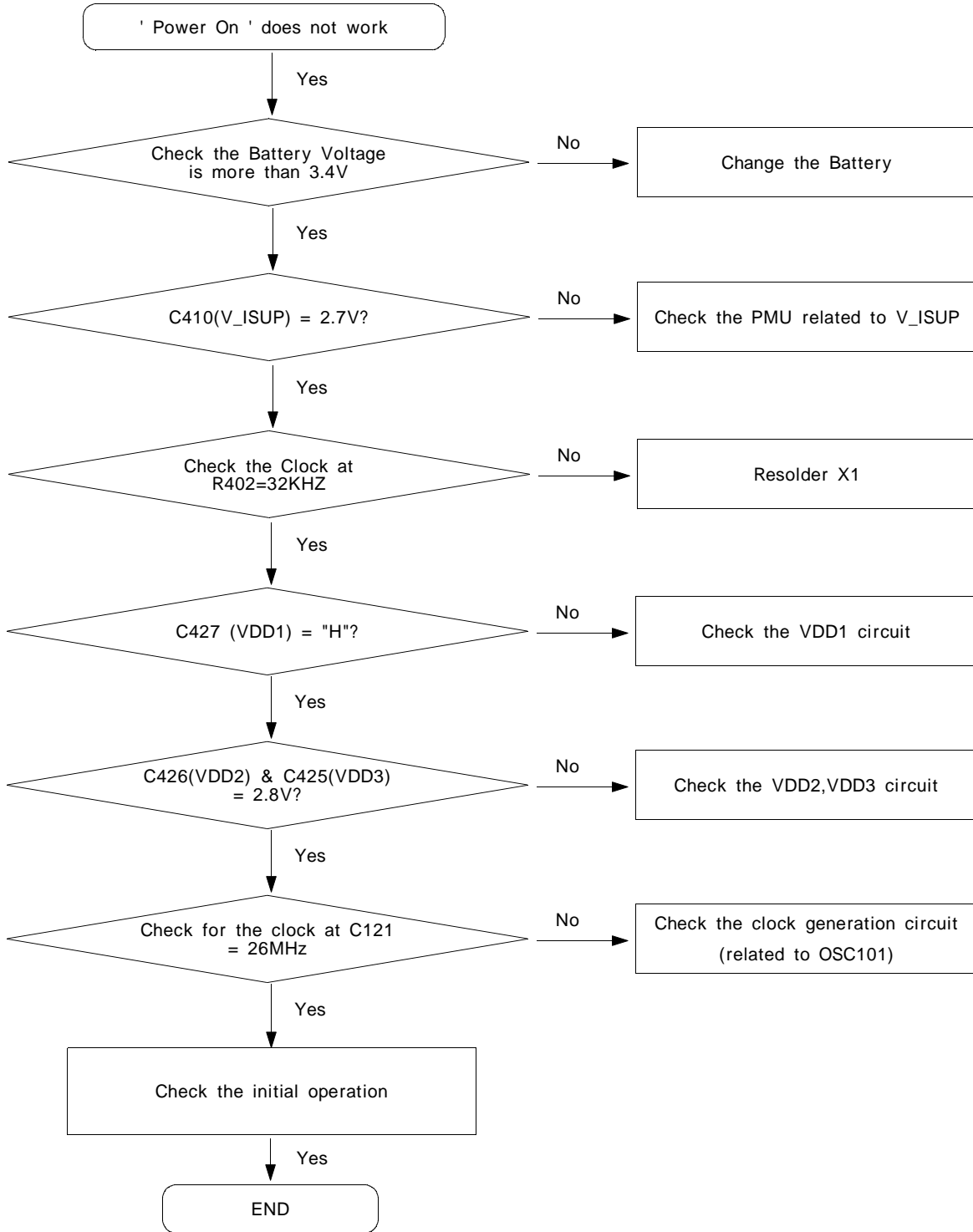

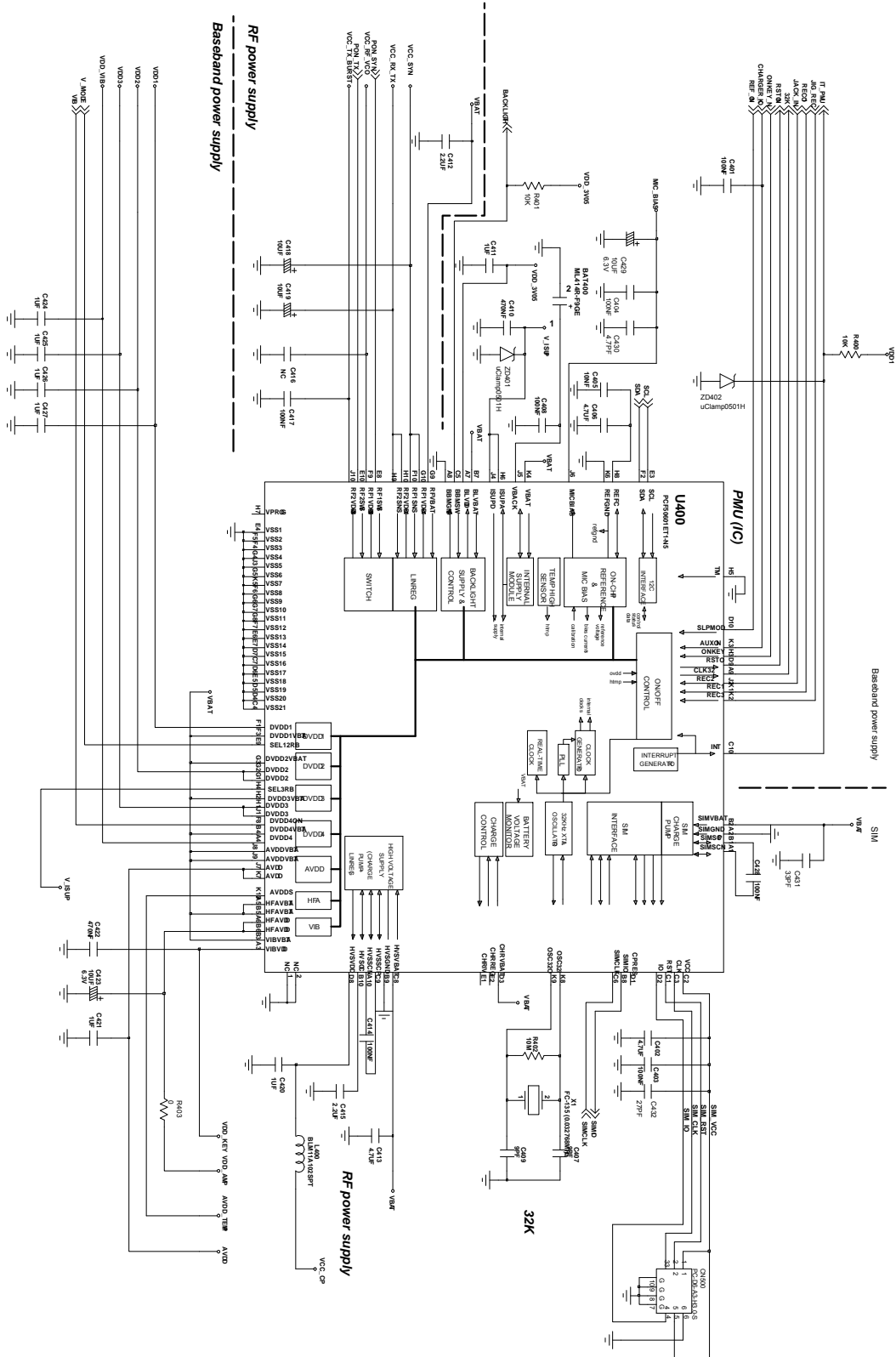

2. Initial

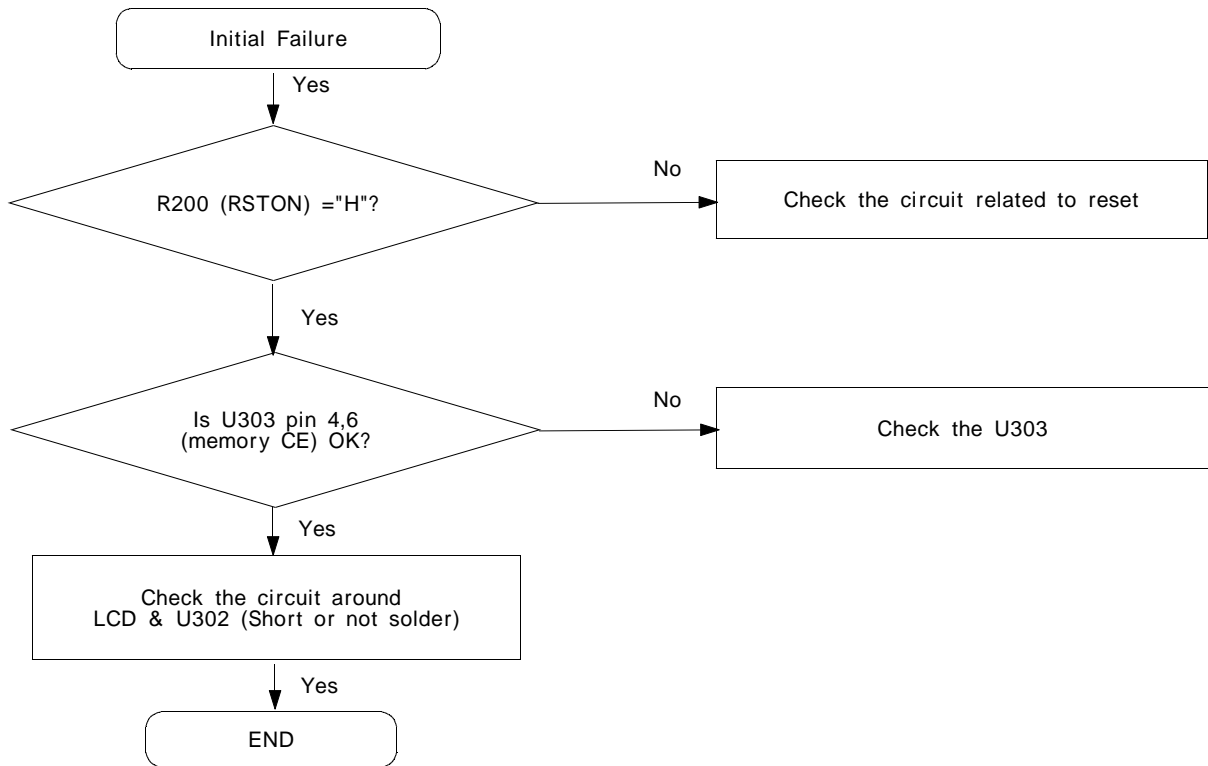

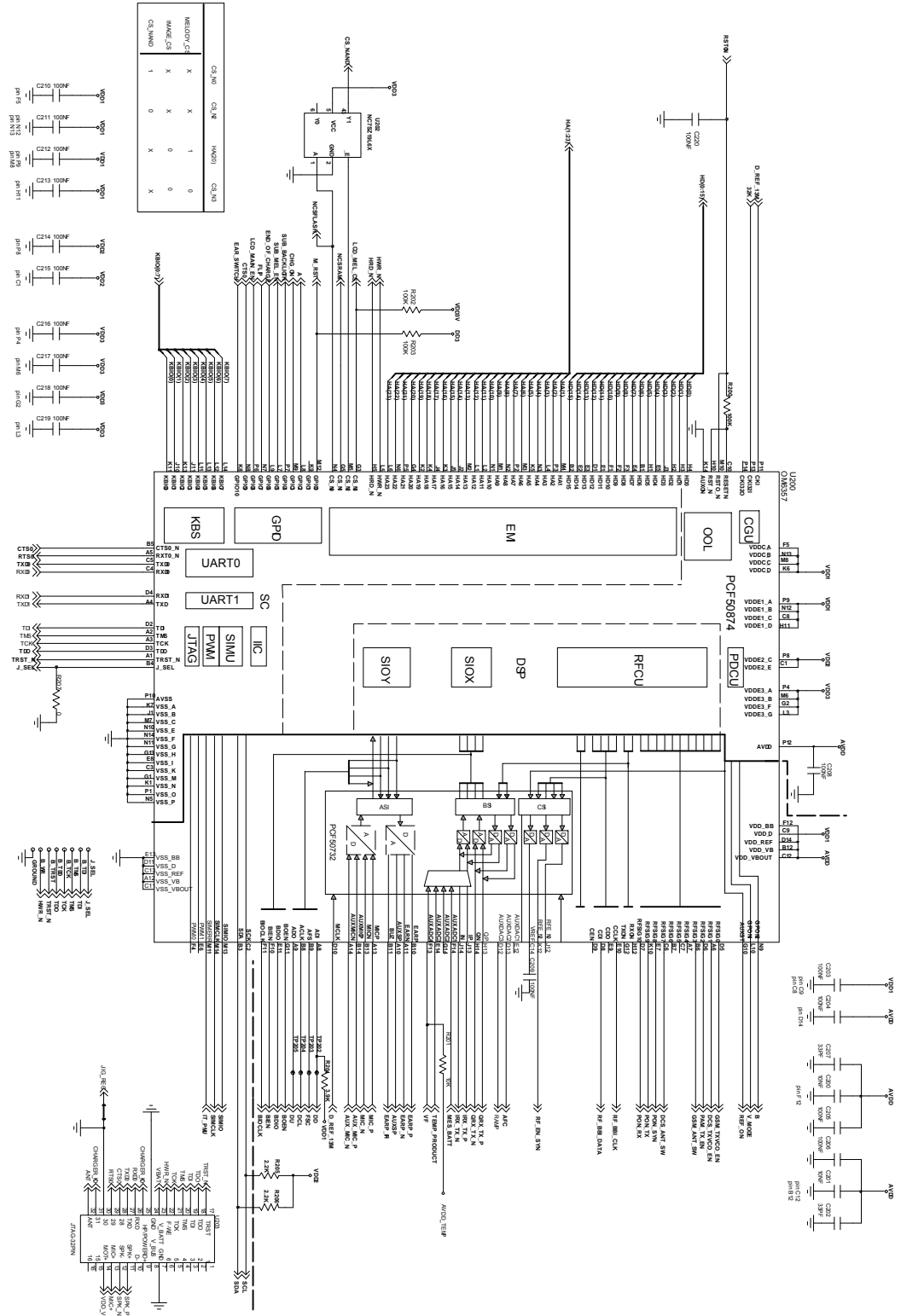

3. Charging Part

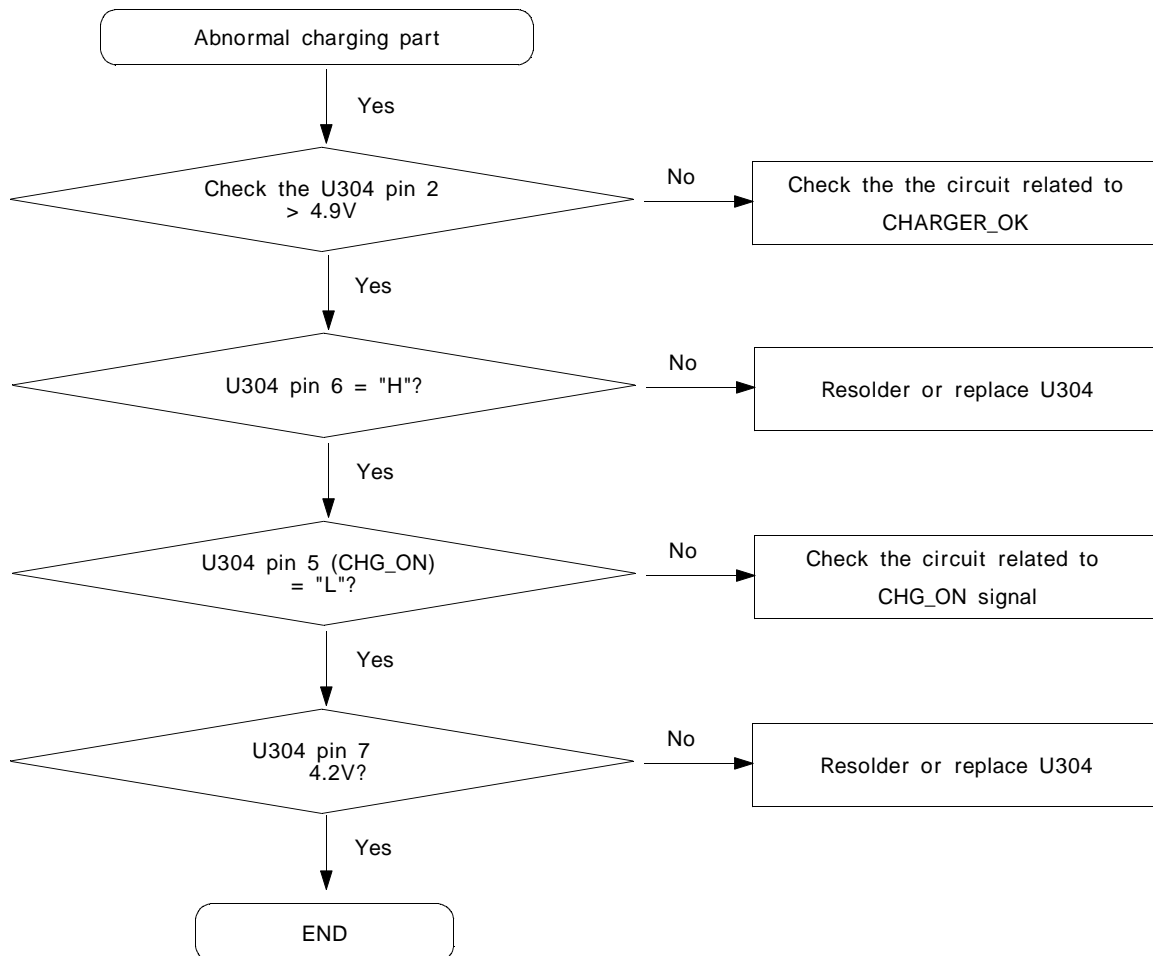

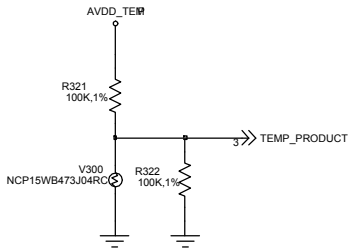
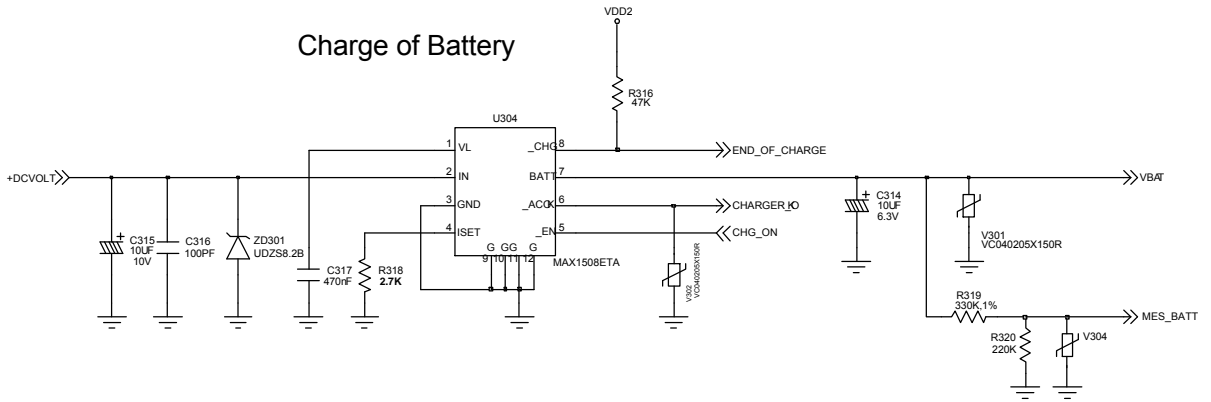

THERMISTER

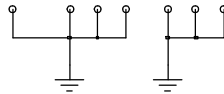

PCB_HOLE

4. Sim Part

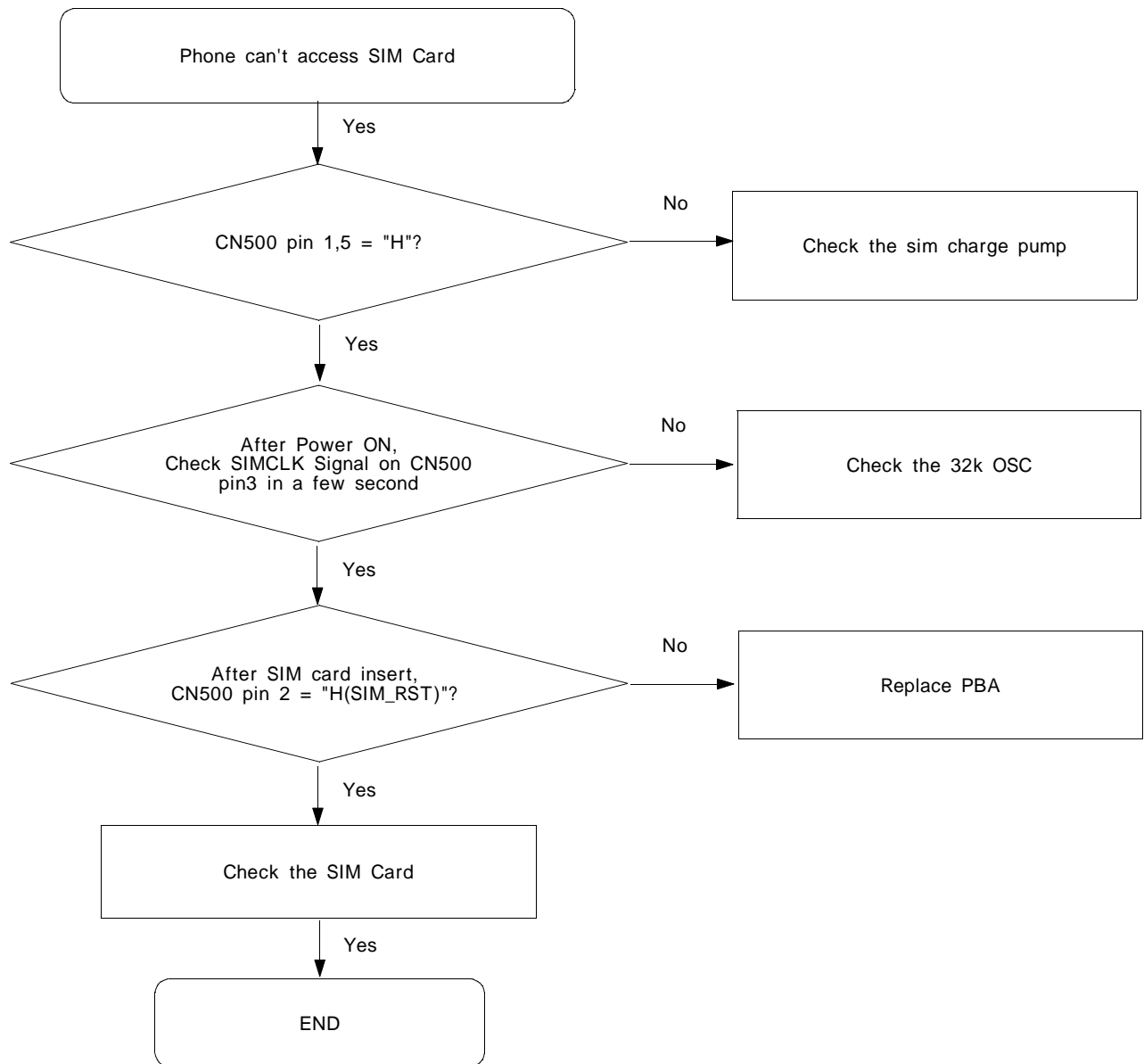

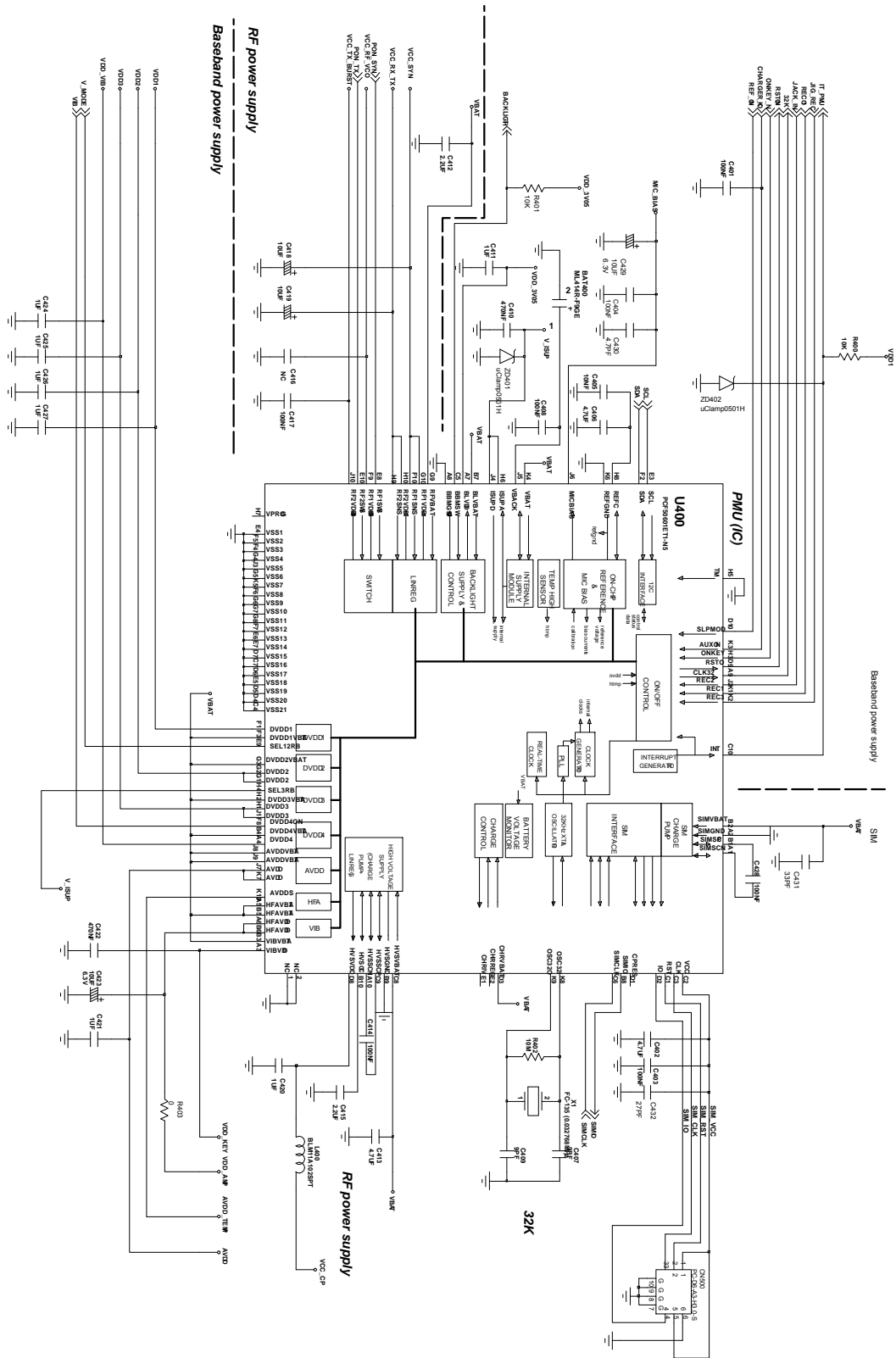

5. Microphone Part

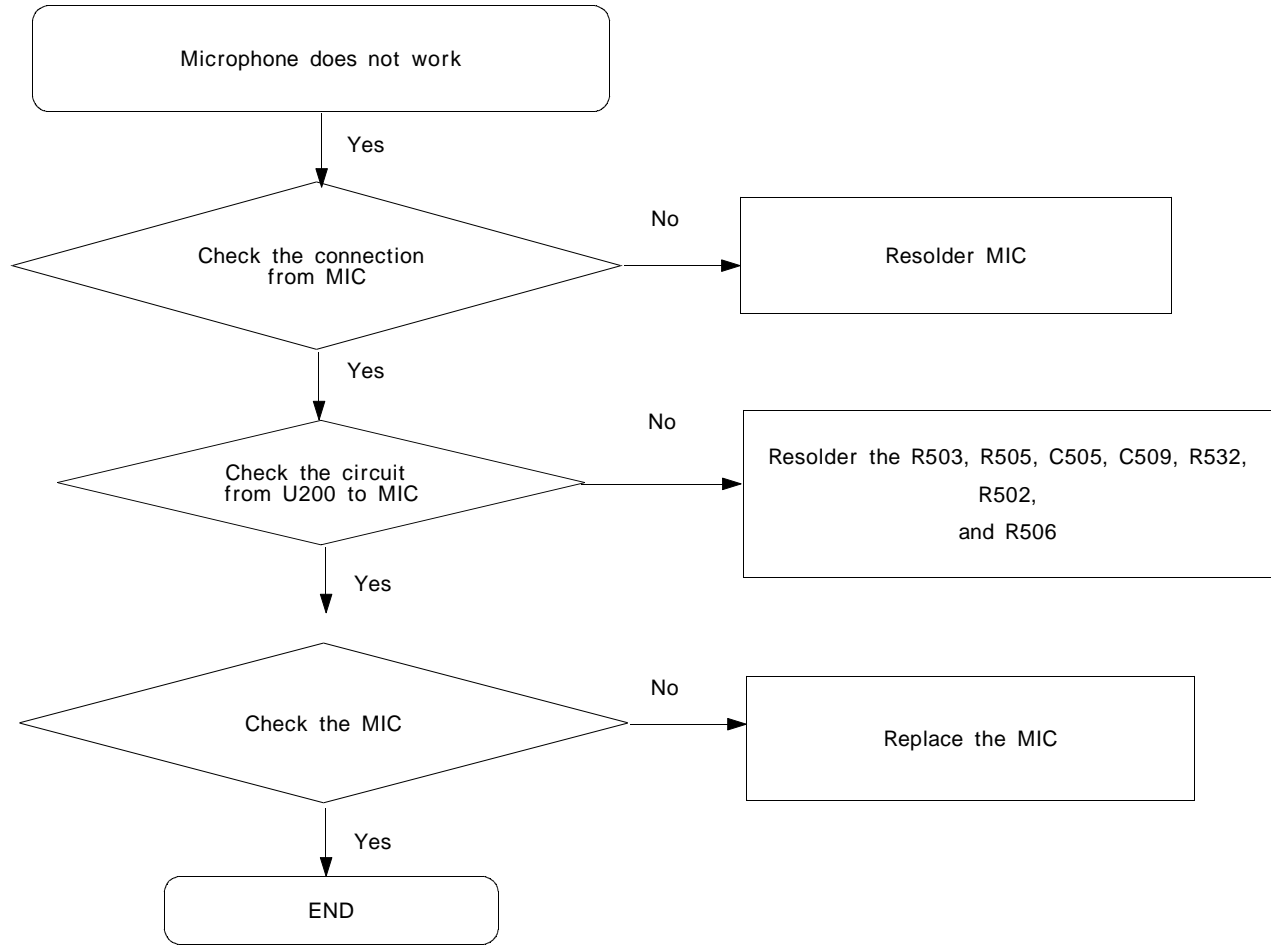

Microphone

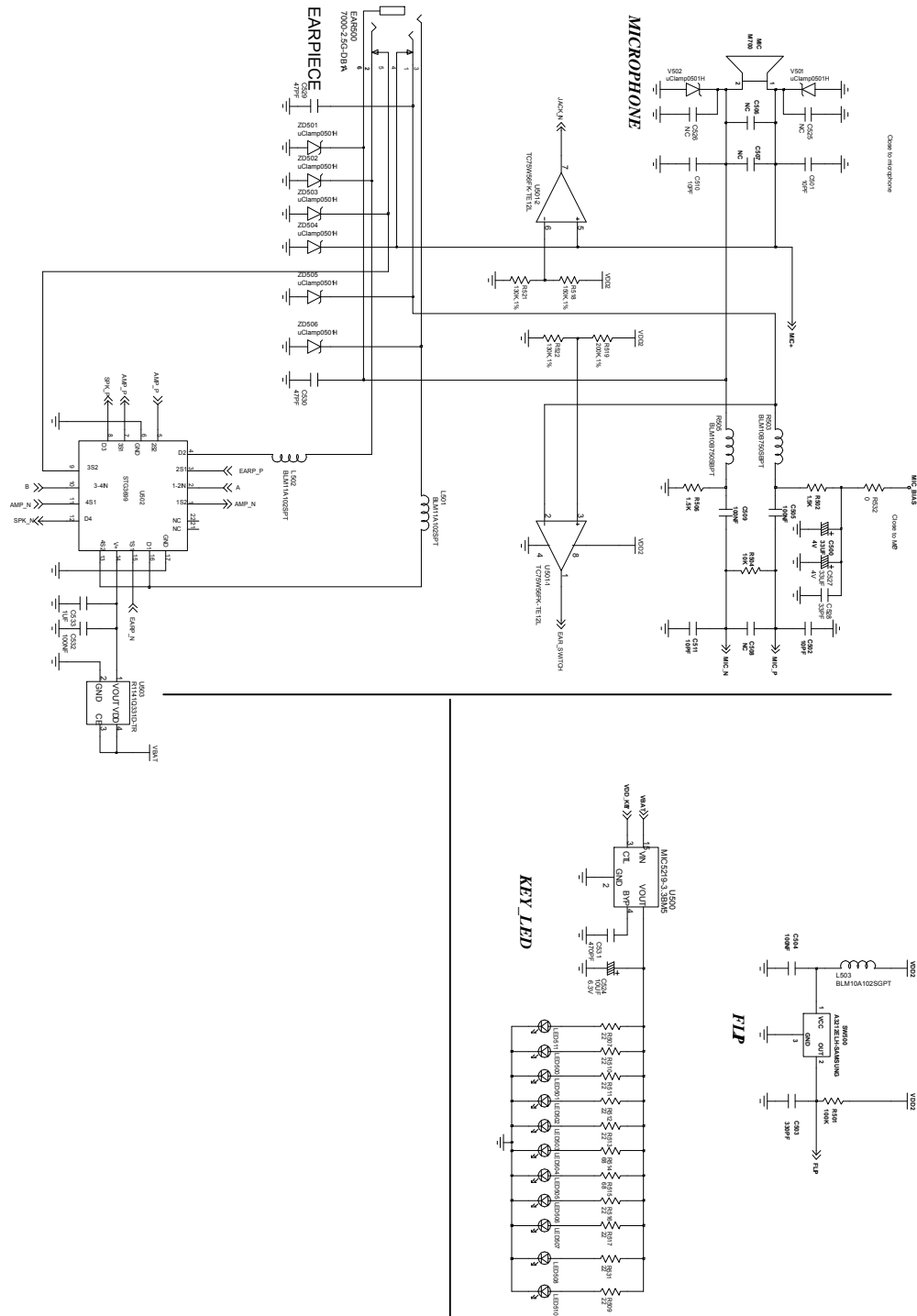

6. Speaker Part(Melody)

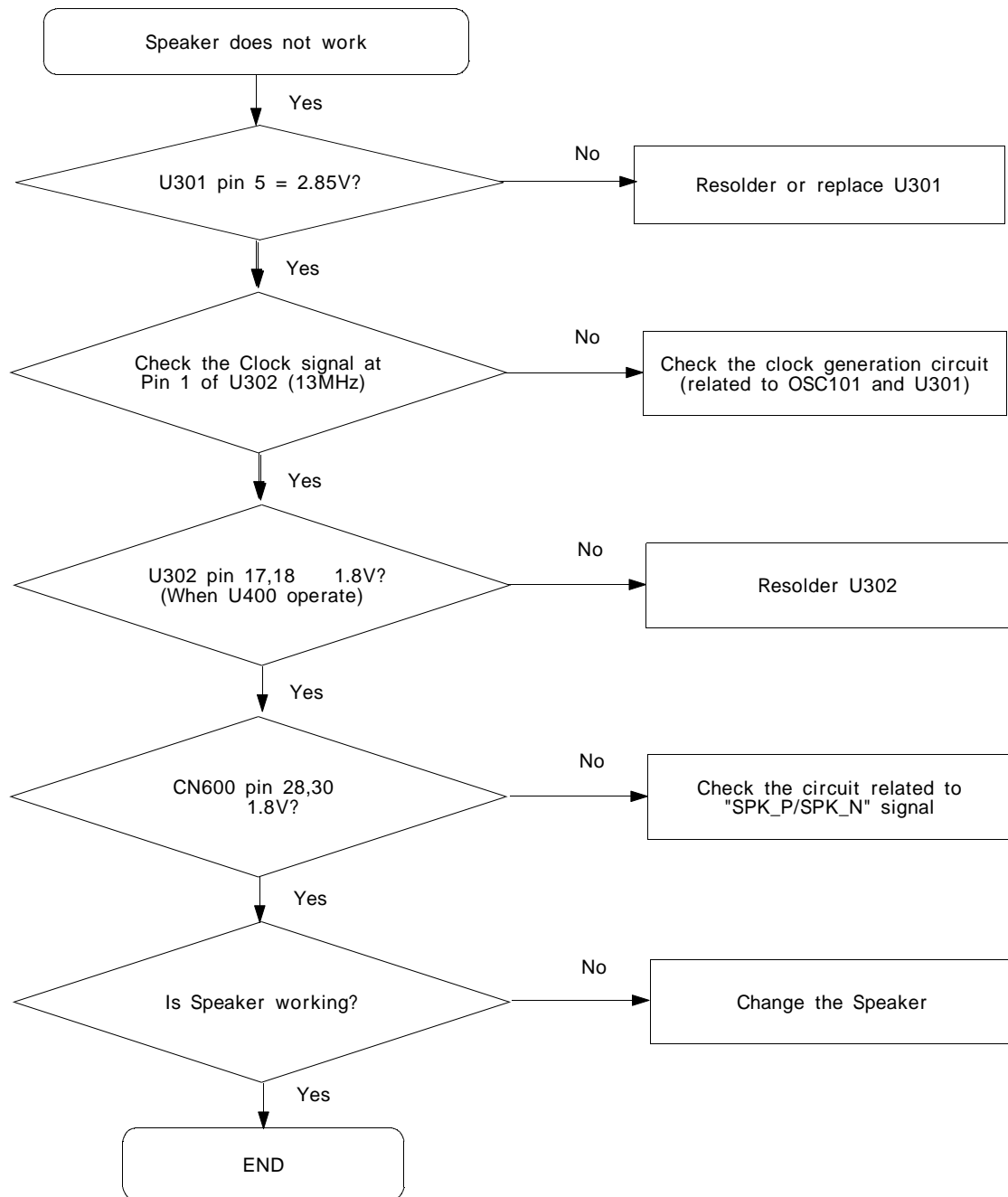

Speaker

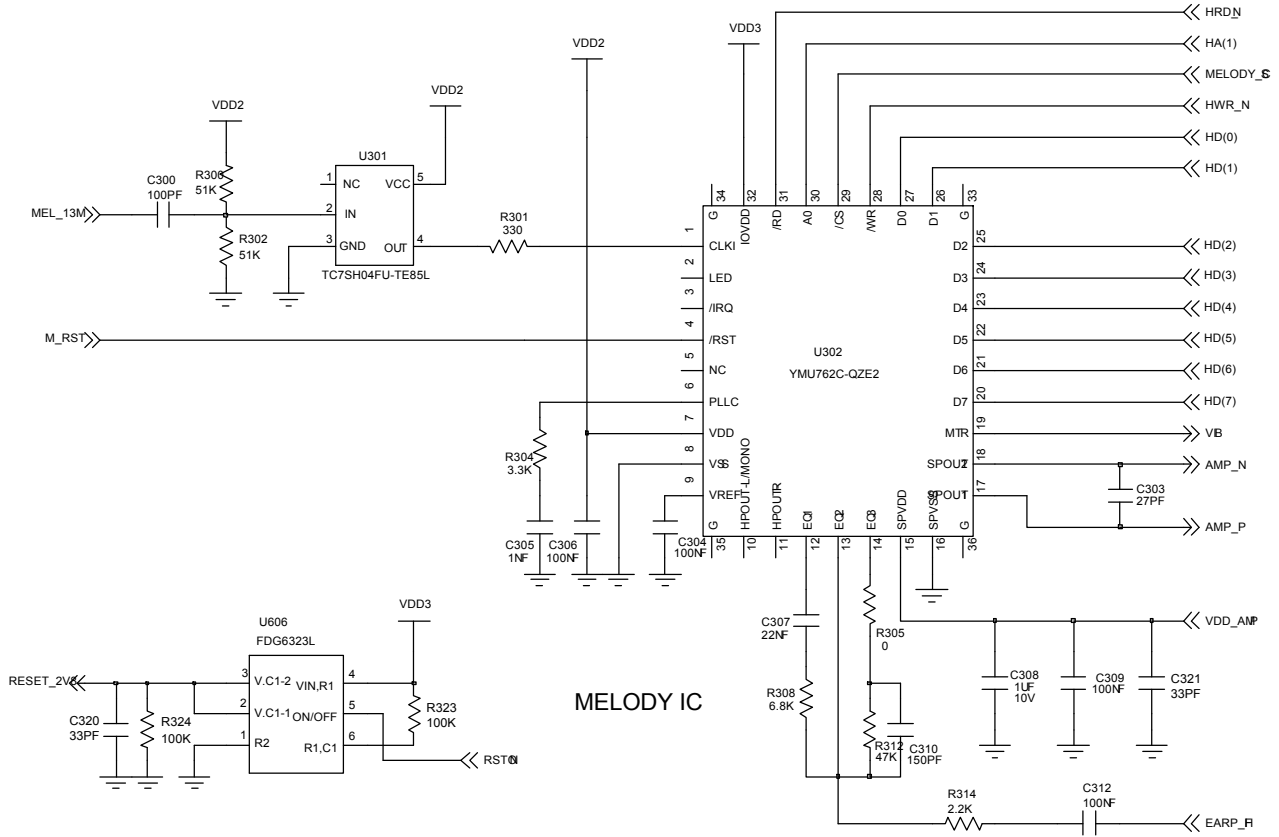

7. Key Data Input

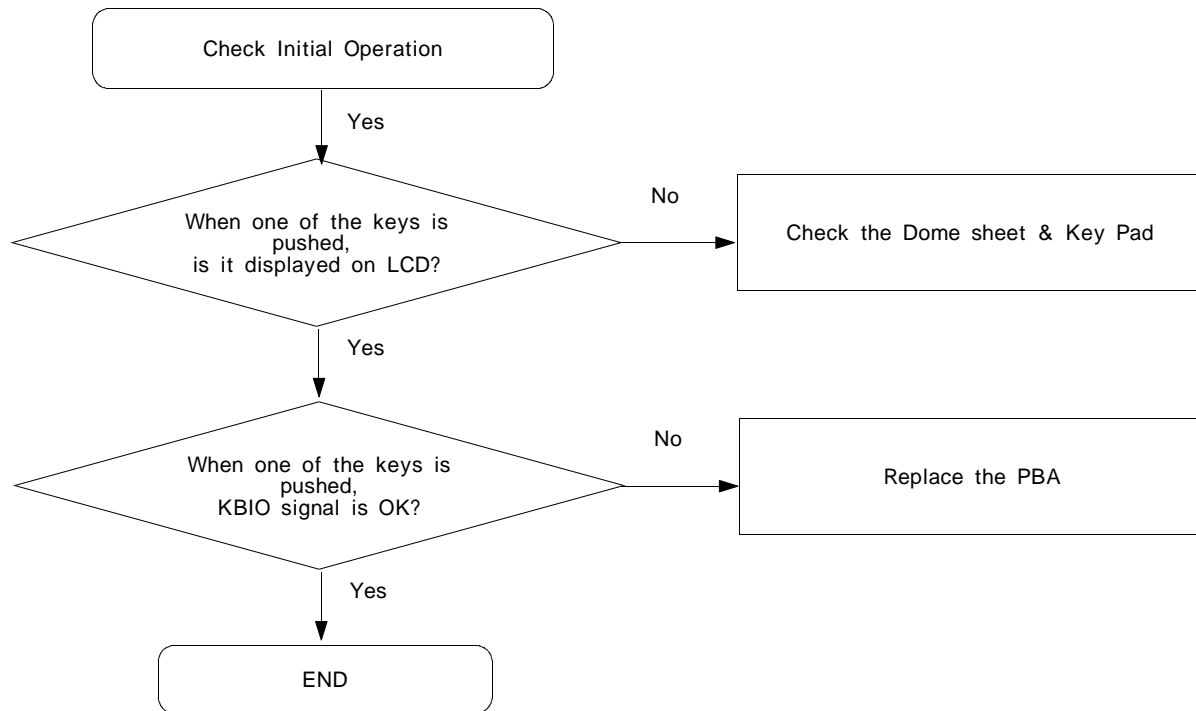

8. Receiver Part

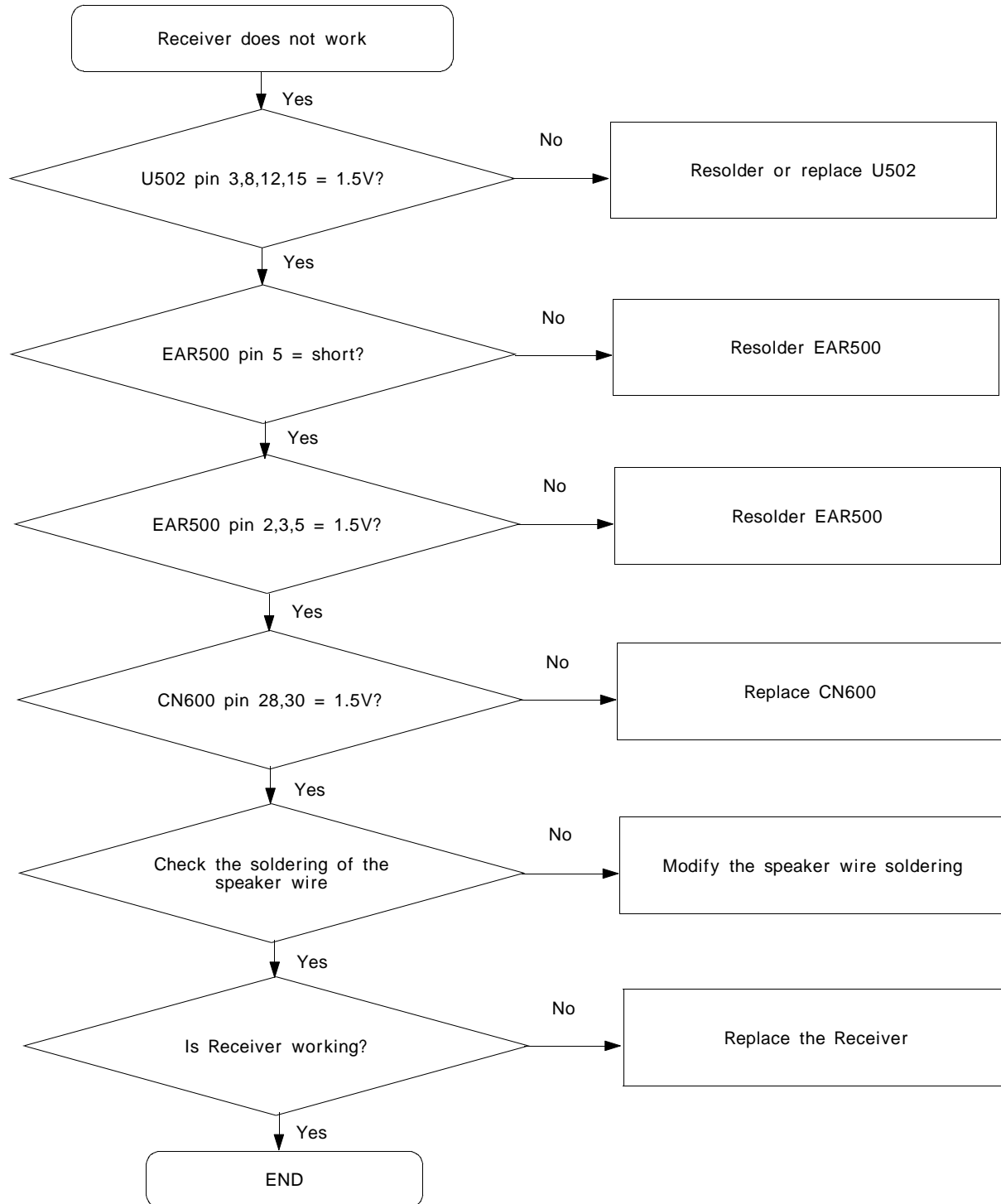

9. Back Light (for Color Main LCD)

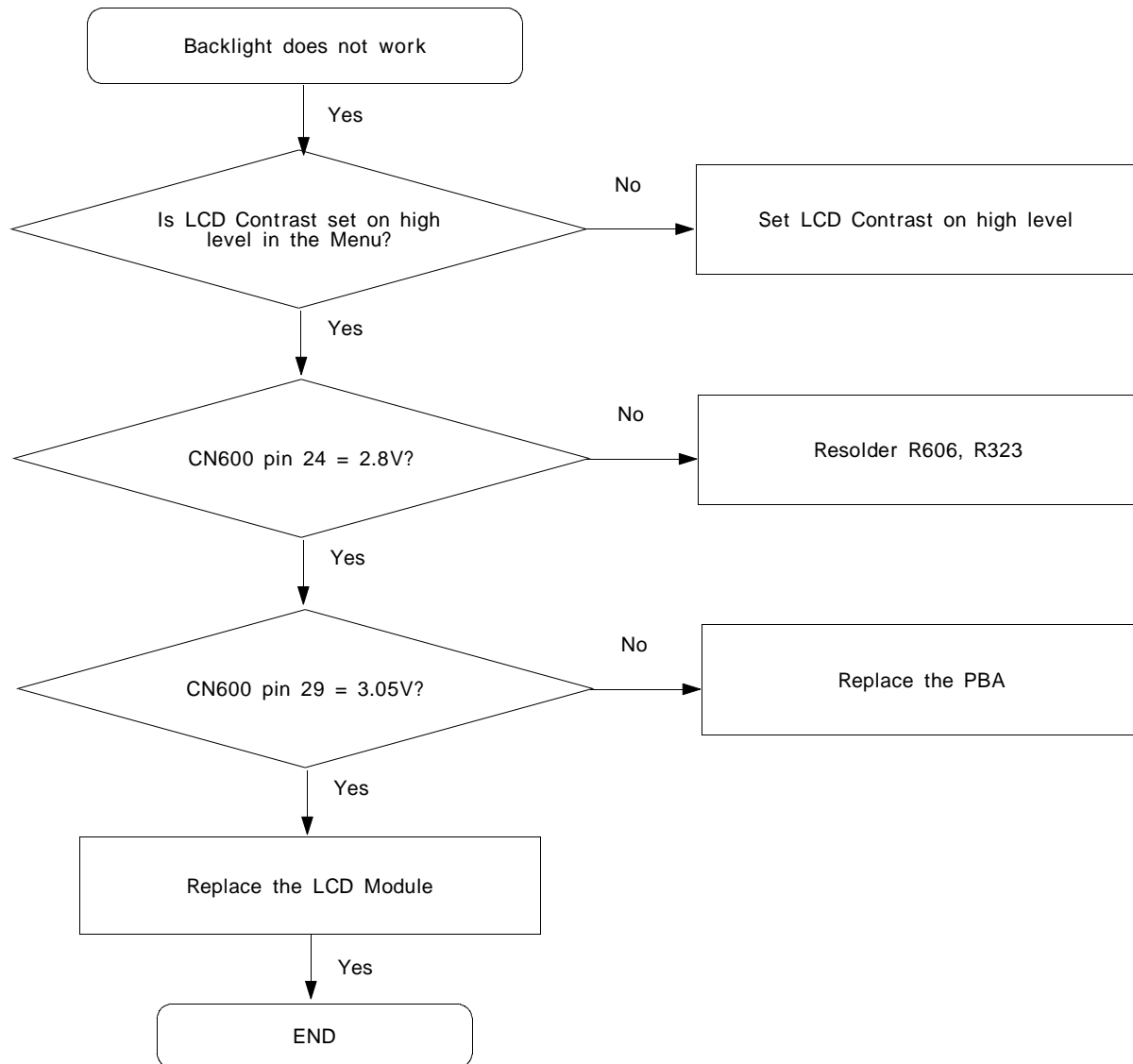

10. Key Back Light

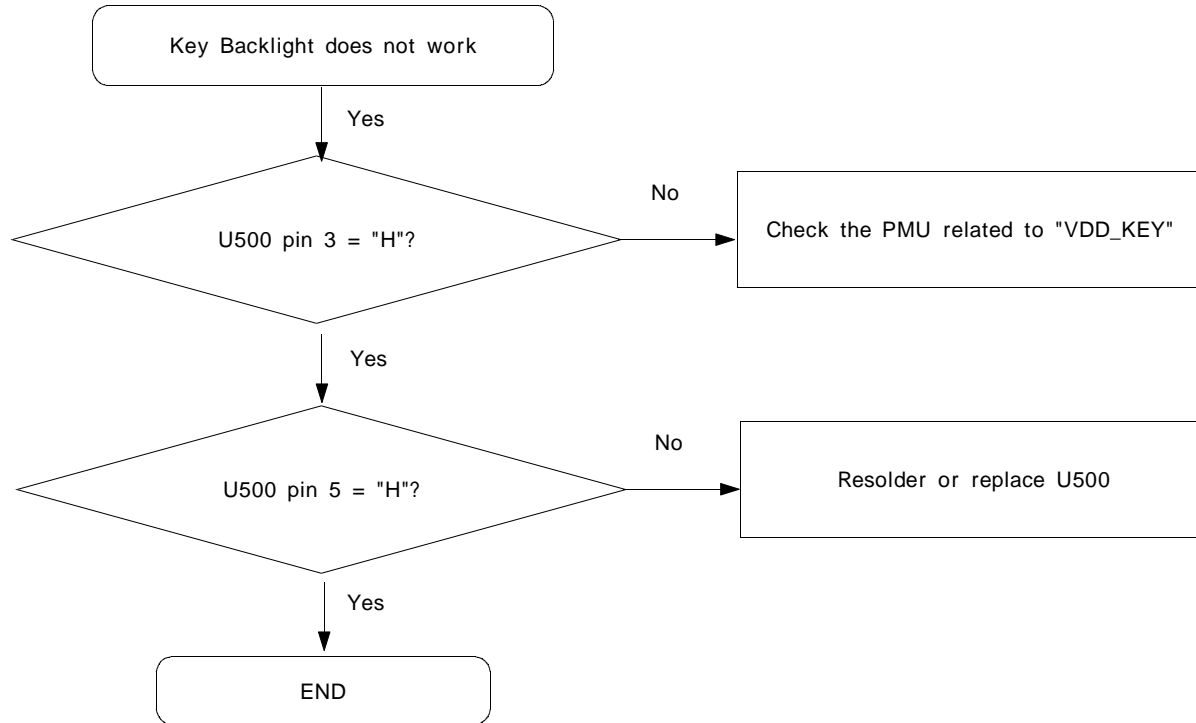

11. GSM Receiver

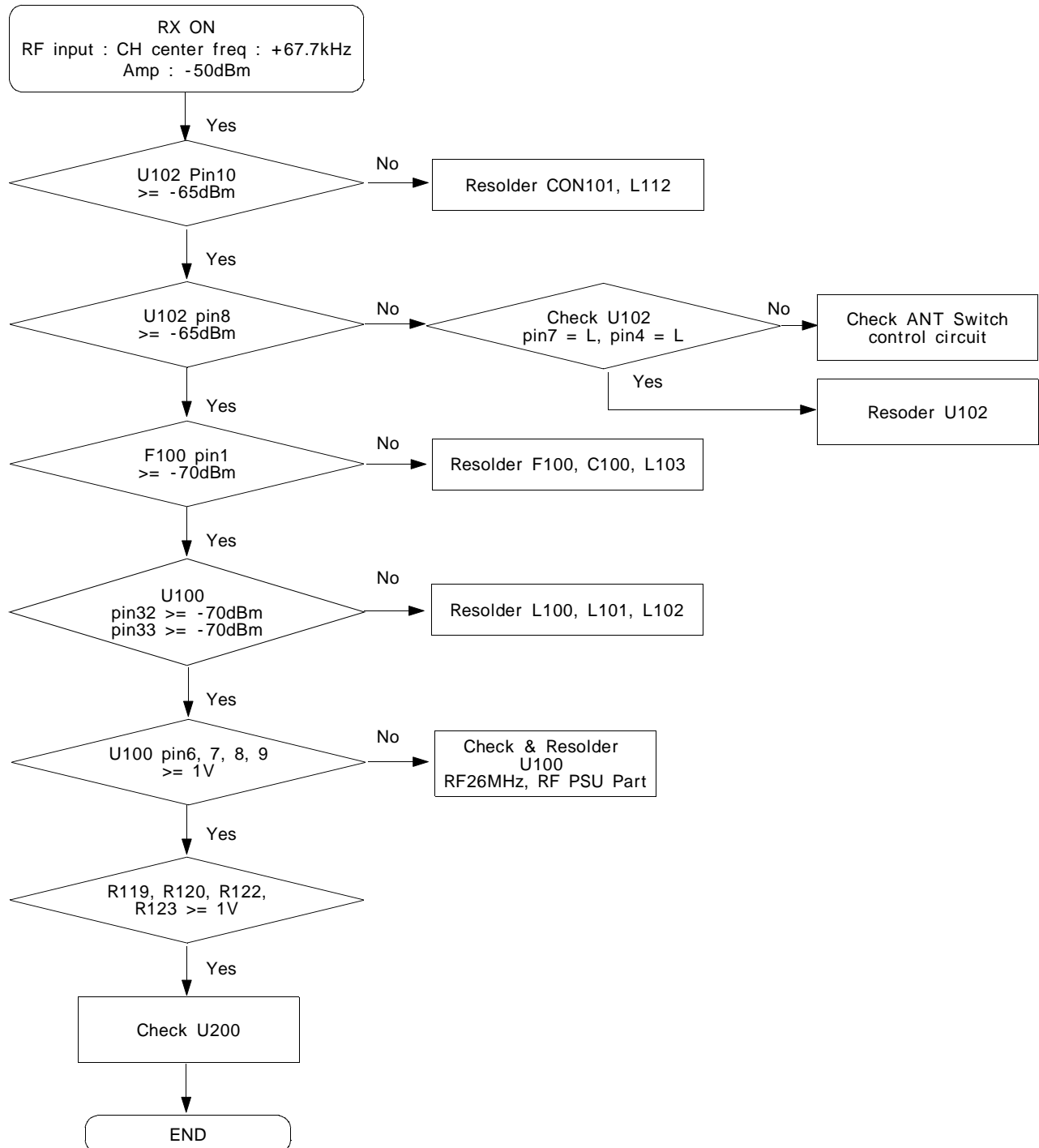

12. GSM Transmitter

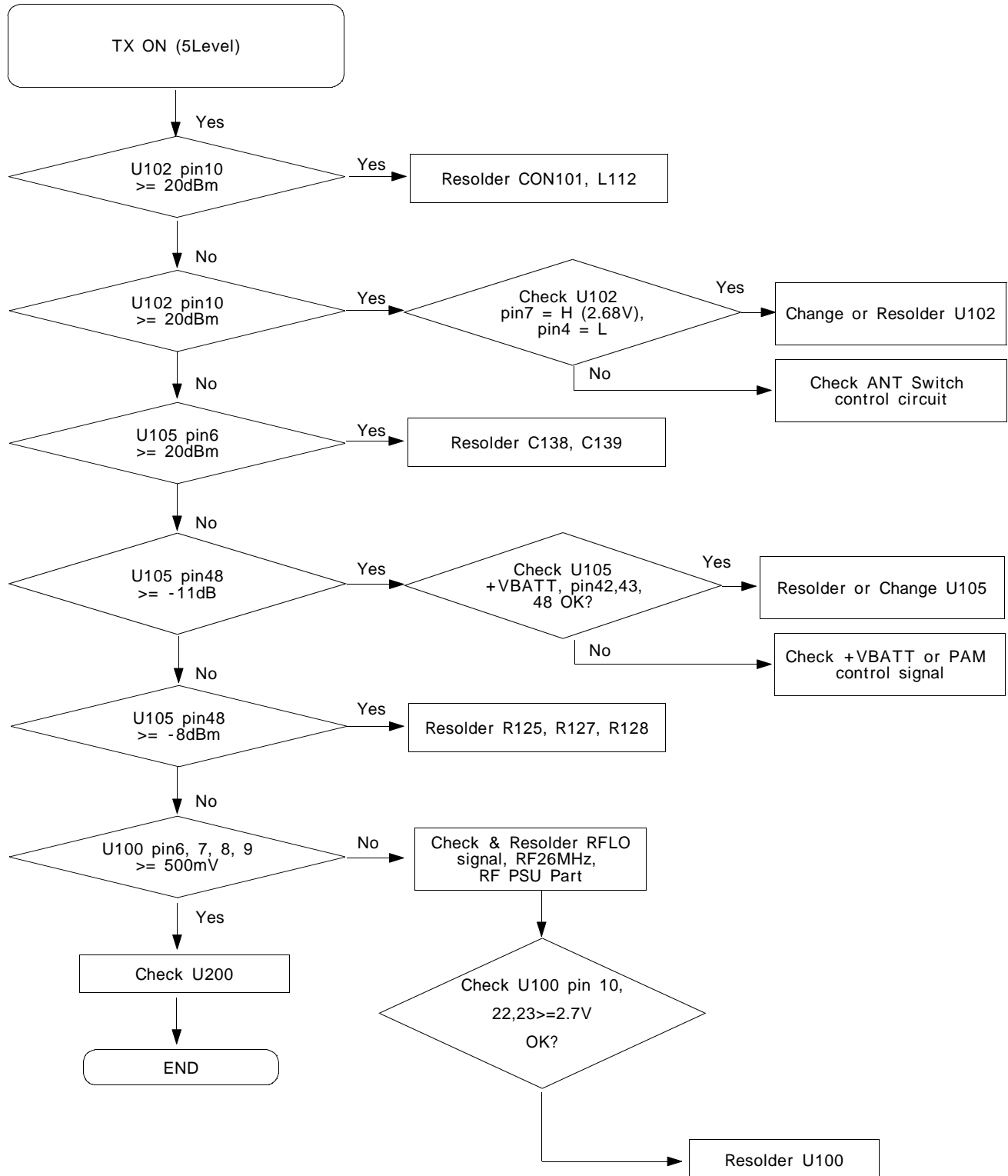

13. DCS Receiver

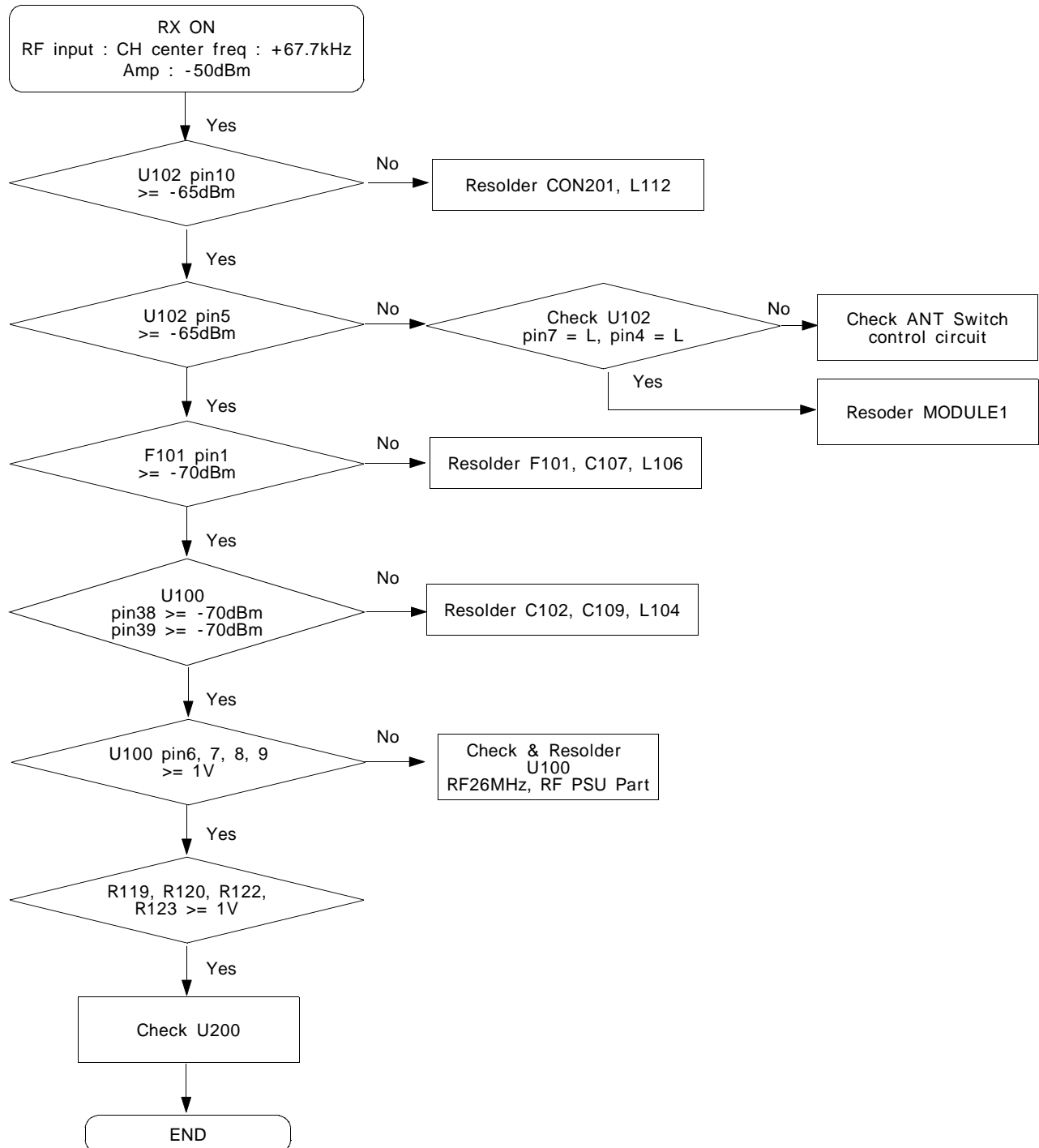

14. DCS Transmitter

