

SAMSUNG

GSM TELEPHONE

SGH-S730i

SERVICE *Manual*

GSM TELEPHONE



CONTENTS

1. Specification
2. Exploded View and Parts list
3. Chart of Troubleshooting
4. Array course control
5. Block Diagrams
6. PCB Diagrams
7. MAIN Electrical Parts List
8. Reference data
9. Safety Precautions
10. Product Function

**SAMSUNG
ELECTRONICS**



GSPN (Global Service Partner Network)

Country	Web Site
North America	service.samsungportal.com
Latin America	latin.samsungportal.com
CIS	cis.samsungportal.com
Europe	europe.samsungportal.com
China	china.samsungportal.com
Asia	asia.samsungportal.com
Mideast & Africa	mea.samsungportal.com

Contents

1. Specification

1-1. GSM General Specification	1-1
1-2. GSM TX power class	1-2

2. Exploded View and Parts list

2-1. Cellular phone Exploded View	2-1
2-2. Cellular phone Parts list	2-2
2-3. Disassembly	2-9
2-4. Assembly	2-11

3. Chart of Troubleshooting

3-1. Baseband	3-1
3-1-1. Power ON	3-1
3-1-2. System Initial	3-5
3-1-3. SIM Part	3-8
3-1-4. Charging Part	3-10
3-1-5. Microphone Part	3-12
3-1-6. Speaker Part	3-15
3-1-7. Camera Part	3-18
3-1-8. LCD	3-21
3-2. RF	3-13
3-2-1. EGSM Rx	3-23
3-2-2. DCS Rx	3-24
3-2-3. PCS Rx	3-25
3-2-4. EGSM Tx	3-27
3-2-4. DCS & PCS Tx	3-28
3-2-6. BLUETOOTH	3-30

Contents

4. Array course control

4-1. Downloading Binary Files	4-2
4-2. Pre-requisite for Downloading	4-2
4-3. S/W Downloader Program	4-3

5. Block Diagrams

6. PCB Diagrams

7. MAIN Electrical Parts List

8. Reference data

8-1. Reference Abbreviate	8-1
---------------------------------	-----

9. Safety Precautions

9-1. Repair Precaution	9-1
9-2. ESD(Electrostatically Sensitive Devices) Precaution	9-2

10. Product Function

1. Specification

1-1. GSM General Specification

	EGSM 900	DCS1800	PCS1900
Freq. Band[MHz] Uplink/Downlink	880~915 925~960	1710~1785 1805~1880	1850~1910 1930~1990
ARFCN range	0~124 & 975~1023	512~885	512~810
Tx/Rx spacing	45 MHz	95 MHz	80 MHz
Mod. Bit rate/ Bit Period	270.833 kbps 3.692 us	270.833 kbps 3.692 us	270.833 kbps 3.692 us
Time Slot Period/Frame Period	576.9 us 4.615 ms	576.9 us 4.615 ms	576.9 us 4.615 ms
Modulation	0.3 GMSK	0.3 GMSK	0.3 GMSK
MS Power	33 dBm~ 5 dBm	30 dBm~ 0 dBm	30 dBm~ 0 dBm
Power Class	4 (max +33 dBm)	1 (max +30 dBm)	1 (max +30 dBm)
Sensitivity	-102 dBm	-100 dBm	-100 dBm
TDMA Mux	8	8	8
Cell Radius	35 Km	2 Km	2 Km

1-2. GSM TX power class

TX Power control level	GSM900	TX Power control level	DCS1800	TX Power control level	PCS1900
5	33±2 dBm	0	30±3 dBm	0	30±3 dBm
6	31±2 dBm	1	28±3 dBm	1	28±3 dBm
7	29±2 dBm	2	26±3 dBm	2	26±3 dBm
8	27±2 dBm	3	24±3 dBm	3	24±3 dBm
9	25±2 dBm	4	22±3 dBm	4	22±3 dBm
10	23±2 dBm	5	20±3 dBm	5	20±3 dBm
11	21±2 dBm	6	18±3 dBm	6	18±3 dBm
12	19±2 dBm	7	16±3 dBm	7	16±3 dBm
13	17±2 dBm	8	14±3 dBm	8	14±3 dBm
14	15±2 dBm	9	12±4 dBm	9	12±4 dBm
15	13±2 dBm	10	10±4 dBm	10	10±4 dBm
16	11±3 dBm	11	8±4 dBm	11	8±4 dBm
17	9±3 dBm	12	6±4 dBm	12	6±4 dBm
18	7±3 dBm	13	4±4 dBm	13	4±4 dBm
19	5±3 dBm	14	2±5 dBm	14	2±5 dBm
		15	0±5 dBm	15	0±5 dBm

2. Exploded View and Parts List

2-1. Cellular phone Exploded View

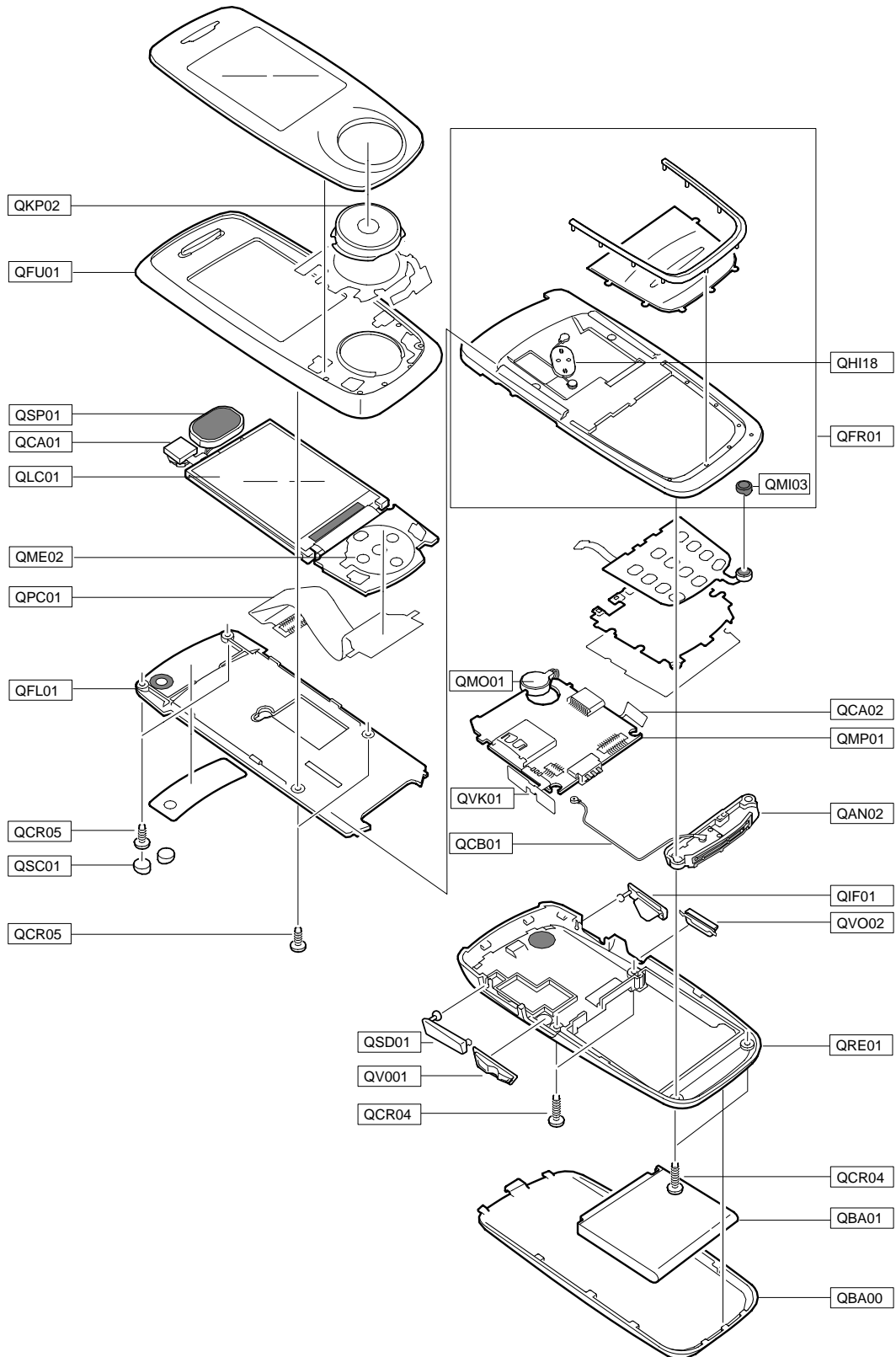

2-2. Cellular phone Parts list

Design LOC	Description	SEC CODE
QAN02	ANTENNA-SGHS730I	GH42-01227A
QBA00	PMO-COVER BATTERY	GH72-38002B
QBA01	INNER BATTERY PACK-800MAH,BLK,	GH43-02837A
QCA01	CAMERA MODULE	GH59-04240A
QCA02	KEY FPCB-SGHS730I,POWER 1 KEY	GH59-04243A
QCB01	CBF COAXIAL CABLE-SGHS730I	GH39-00794A
QCR04	SCREW-MACHINE	6001-001479
QCR05	SCREW-MACHINE	6001-001478
QFL01	ASSY CASE-SLIDE LOWER	GH98-03926B
QFR01	ASSY CASE-FRONT	GH98-03927B
QFR01	ASSY CASE-FRONT SLIDE LOWER	GH98-05323B
QFU01	ASSY CASE-SLIDE UPPER	GH98-03925B
QHI18	ASSY HINGE-LINK	GH98-05379A
QIF01	PMO-COVER IF	GH72-37999B
QKP02	ASSY KEYPAD-SUB(XEF/HBI)	GH98-03930B
QLC01	ELA ETC-LCD MODULE ASS'Y	GH96-02558A
QME02	DOME SHEET-SGHS730I,DOME SHEET	GH59-04249A
QMI03	AS-SGHS730I,MIC RUBBER	GH81-06347A
QMO01	MOTOR DC-SPHM500	GH31-00242A
QMP01	PBA MAIN-SGHS730I	GH92-03577A
QPC01	MEA-SLIDE FPCB KIT	GH97-07708A
QRE01	ASSY CASE-REAR	GH98-03928B
QSC01	RUBBER-SCREW CAP	GH73-09505B
QSD01	PMO-COVER SD	GH72-38001B
QSP01	SPEAKER	3001-002160
QVK01	KEY FPCB-SGHS730I,VOL 2 KEY FP	GH59-04242A
QVO01	PMO-VOL KEY	GH72-38004A
QVO02	PMO-POWER KEY	GH72-38003A

Description	SEC CODE
CBF INTERFACE-DLC,X830,BLK,PCB	GH39-00720A
ADAPTOR-SGHE690,BLK,EU,A_TYPE	GH44-01361A
EARPHONE-EARPHONE,SGHE790,MAIN	GH59-03884A
VINYL-BOHO MP3 D	GH74-32937A
TAPE INSU	GH74-21856A
MPR-TAPE FRONT SUS	GH74-30527A
TAPE INSU	GH74-32855A
LABEL(R)-WATER SOAK	GH68-09361A
TAPE INSU	GH74-30683A
TAPE INSU-VOL KEY	GH74-33193A
MPR-TAPE TOUCH B	GH74-30526A
MPR-INSU TAPE CON CON	GH74-31108A
MPR-REMOVE TAPE LCD	GH74-13804A
MPR-TAPE LED	GH74-17926A
MPR-INSU TAPE	GH74-27511A
MPR-VINYL BOHO WIN MAIN	GH74-21426A
TAPE-CAM	GH74-30521A
MANUAL USERS-BOG FRENCH	GH68-14591A
BAG PE	6902-000297
LABEL(P)-UNIT SEAL	GH68-00518B
LABEL(R)-MASTER_FANCE_BOG	GH68-13691B
LABEL(R)-MAIN(XEF)	GH68-14734G
CUSHION-CASE EU	GH69-05370A
BOX(P)-UNIT MAIN EU	GH69-05374A

2-3. Disassembly

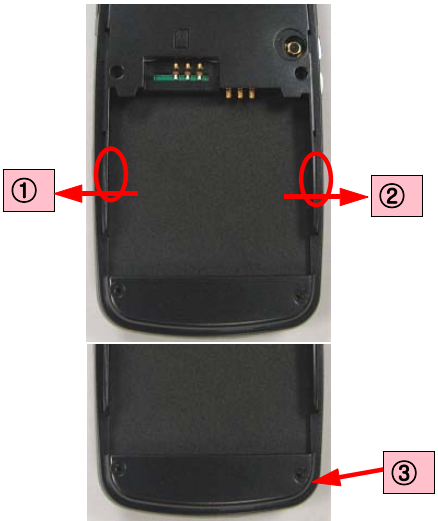
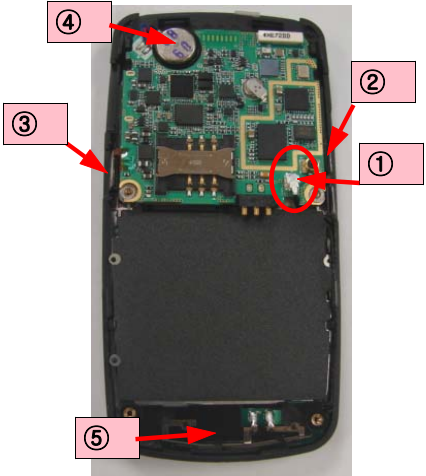
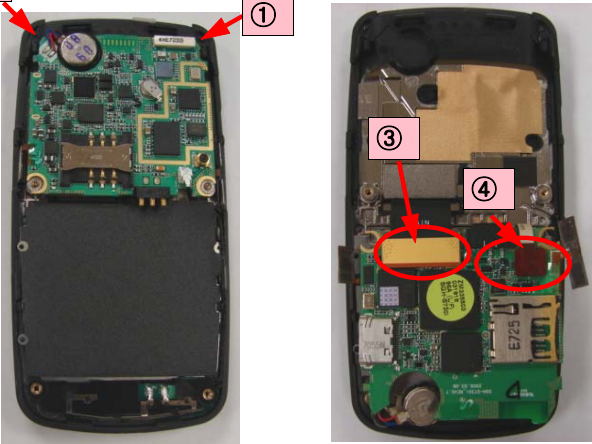
<p>1</p> 	<p>2</p> 
<p>1) Unscrew 4 point of the REAL 2) Open the IF COVER</p> <p>* Caution</p> <p>1) Be care of scratch and molding damage.</p>	<p>1) After pushing outside the REAR ①② LOCKER, disassemble them 2) Disassemble downside of REAR LOCKER</p> <p>* Caution</p> <p>1) Be care of scratch and molding damage.</p>
<p>3</p> 	<p>4</p> 
<p>1) Disassemble the Connector 2) Disassemble the volume key 3) Disassemble the power key 4) Disassemble the MOTOR 5) Disassemble the antenna</p> <p>* Caution</p> <p>1) Be care of scratch and molding damage. Especially MOTOR, VOL, POWER KEY FPCB.</p>	<p>1) Disassemble right side of MAIN B'D LOCKER 2) Disassemble the LOCKER 3) Disassemble SLIDE Connector 4) Disassemble MAIN KEY Connector</p> <p>* Caution</p> <p>1) When you detach the Connector of the main key, Be care of damaging another part</p>

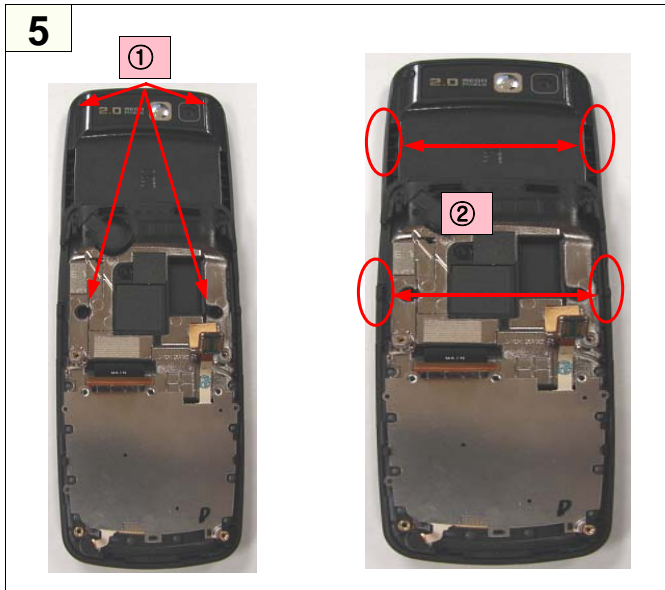

- 1) After disassembling the SCREW COVER, unscrew 4 Point of the SCREW
 - 2) Disassemble the LOCKER using tool
- ※ **Caution**
- 1) Be care of molding damage F-PCB



- 1) Disassemble the SLIDE FPCB carefully
- ※ **Caution**
- 1) Be care of scratch and molding damage.

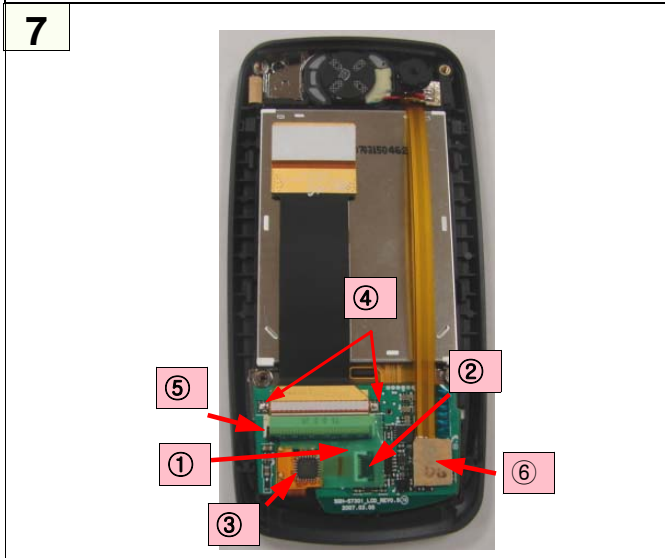

- 1) Detach the protecting sheet
 - 2) OPEN the touch key Connector
 - 3) Detach the touch key IC
 - 4) Detach the SOLDER
 - 5) Detach it, After opening the Connector of the slide FPCB
 - 6) OPEN the CAMERA Connector
- ※ **Caution**
- 1) When you OPEN touch key, Be care of damaging F-PCB

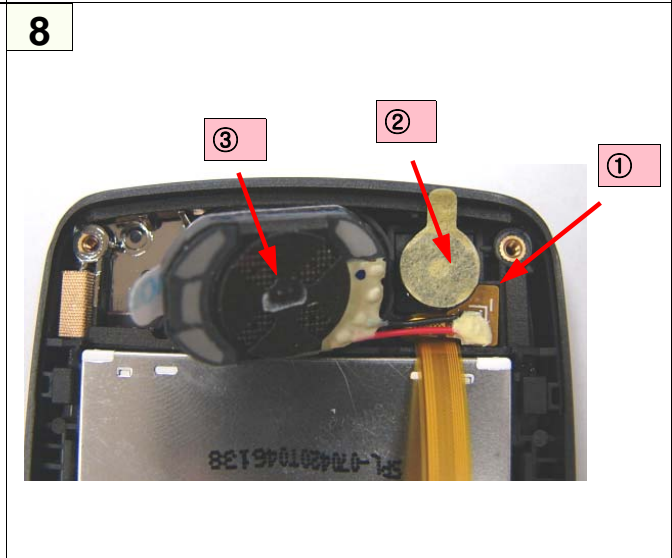

- 1) OPEN the SPK SOLDER PCB
 - 2) OPEN the CAMERA
 - 3) OPEN the SPEAKER
- ※ **Caution**
- 1) When you open CAMERA&SPK, Be care of damaging F-PCB

9

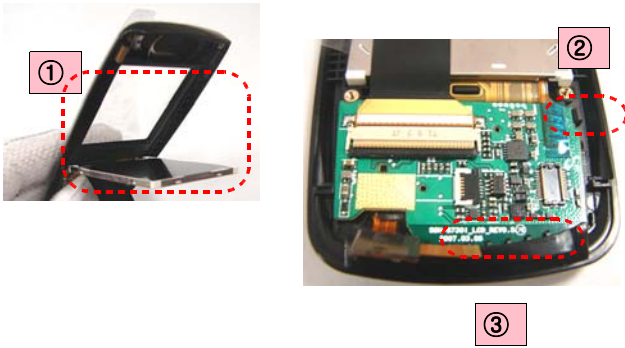

- 1) OPEN the LCD
- 2)& 3) OPEN LOCKER and OPEN the PBA

※ **Caution**

- 1) Be care of scratch and molding damage.
Especially LCD FPCB

2-4. Assembly

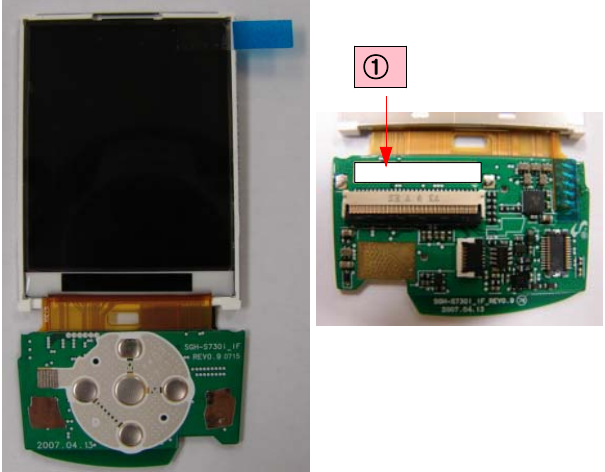
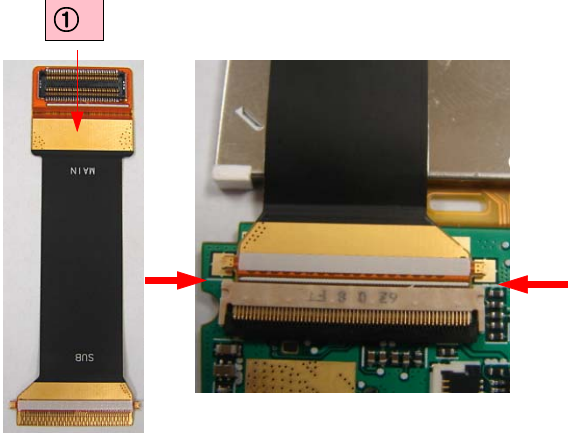
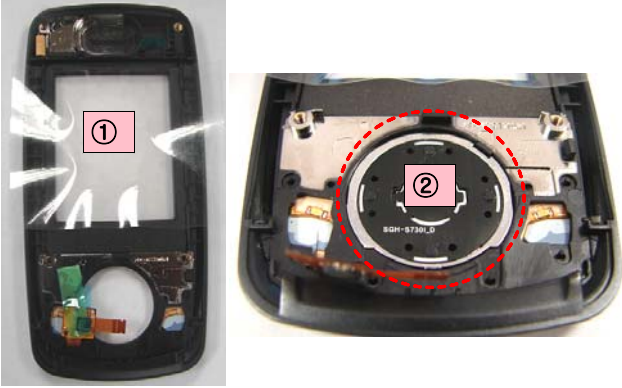
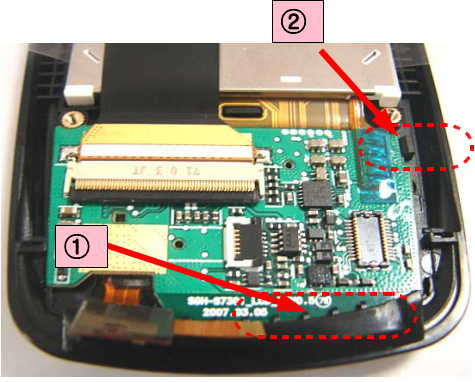
<p>1</p> 	<p>2</p> 
<p>1) Attach GASKET BASE TAPE ① Part Code: GH74-31137A</p>	<p>1) GASKET BASE TAPE and Insert SLIDE FPCB ① Part Code: GH41-01635A</p>
<p>3</p> 	<p>4</p> 
<p>1) Insert the NAVIKEY ① Part Code: GH74-31137A ② Part Code: GH98-03930A</p>	<p>1) Assemble LCD ASS'Y ① → ② (take turns) Part Code: GH96-02558A(LCD ASS'Y)</p>

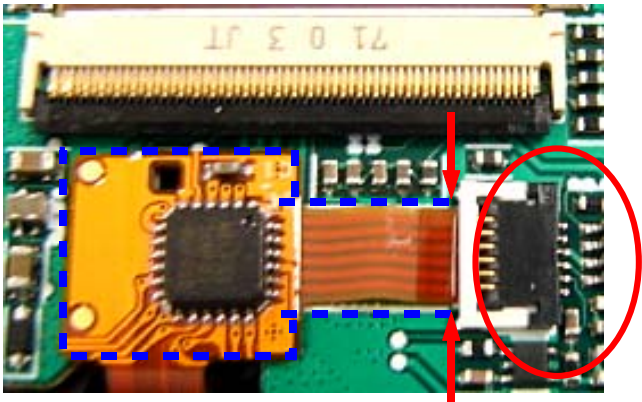
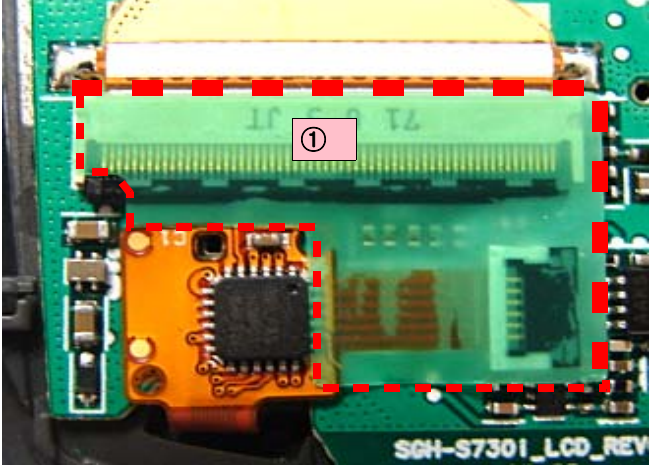
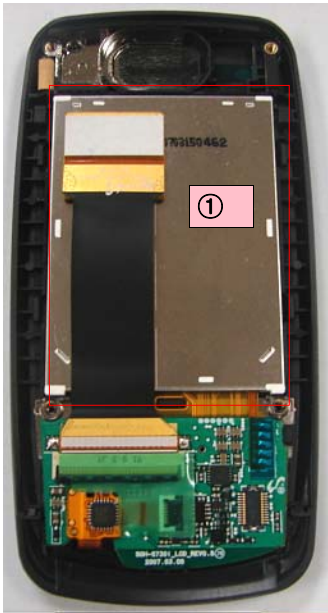
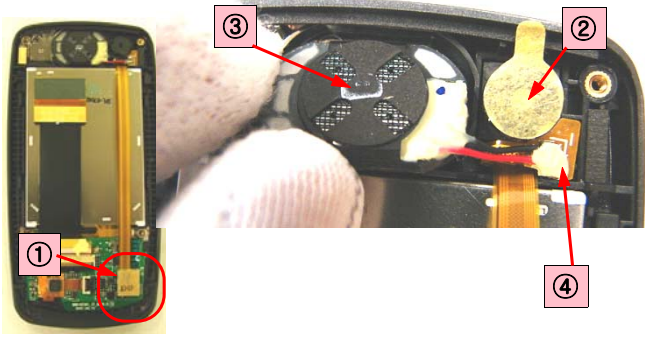
<p>5</p> 	<p>6</p> 
<p>1) Assemble IC part of touch key 2) Insert touch key Connector and LOCKING</p>	<p>1) Attach fixing protecting sheet ① Part Code: GH74-31108A</p>
<p>7</p> 	<p>8</p>  <p>1) Insert the CAMERA Connector whit "Toc" sound 2) ②③④ insert and fix ② Part Code: GH59-04240A(CAMERA) ③ Part Code: 3001-002160 (SPK)</p>
<p>1) Assemble the LCD</p>	

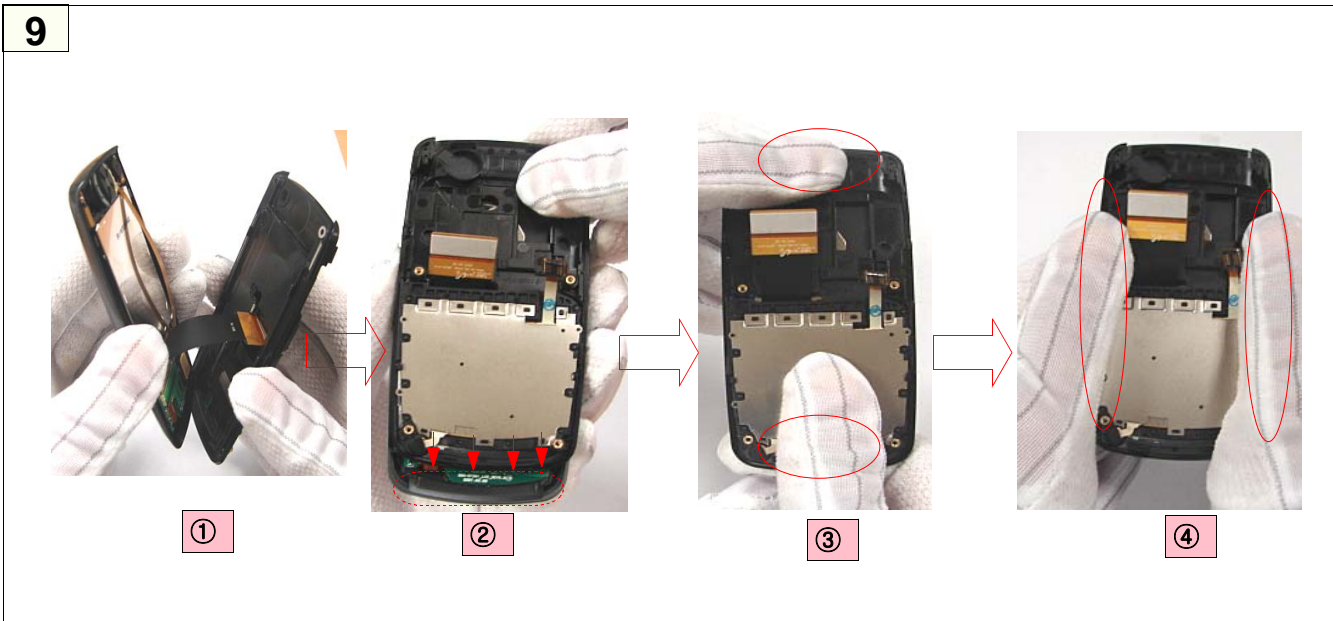

1) Assemble them in numerical order



1) Screw 4 Point of SCREWS
Part Code:6001-001478 SCREW

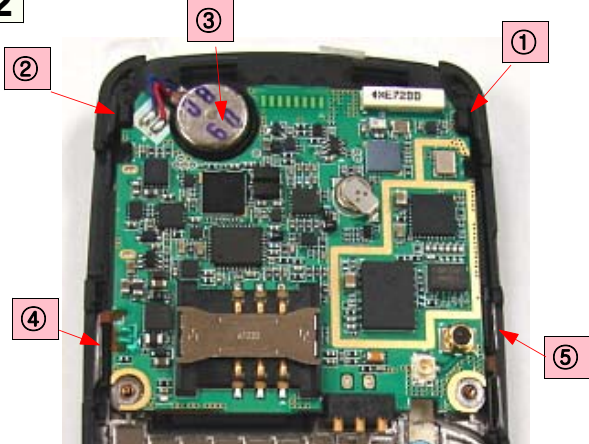
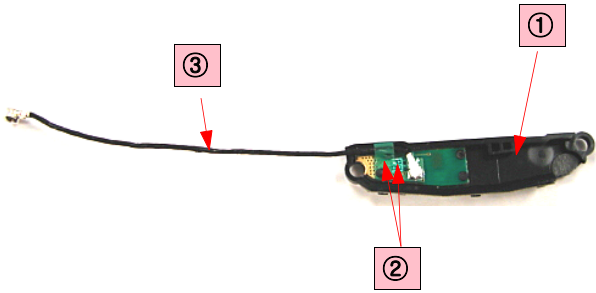
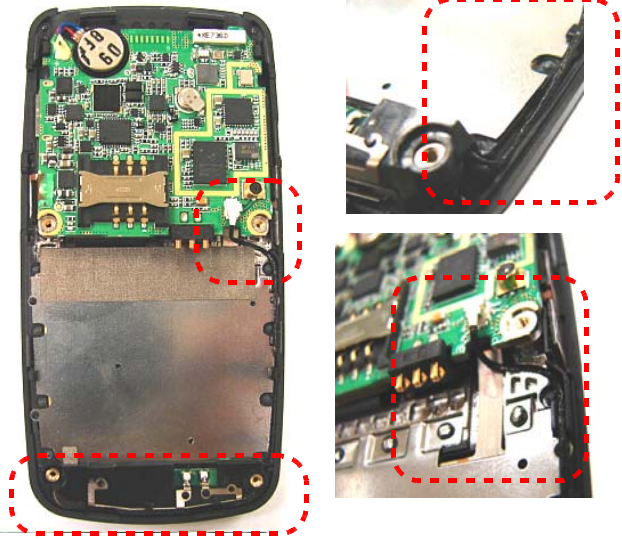
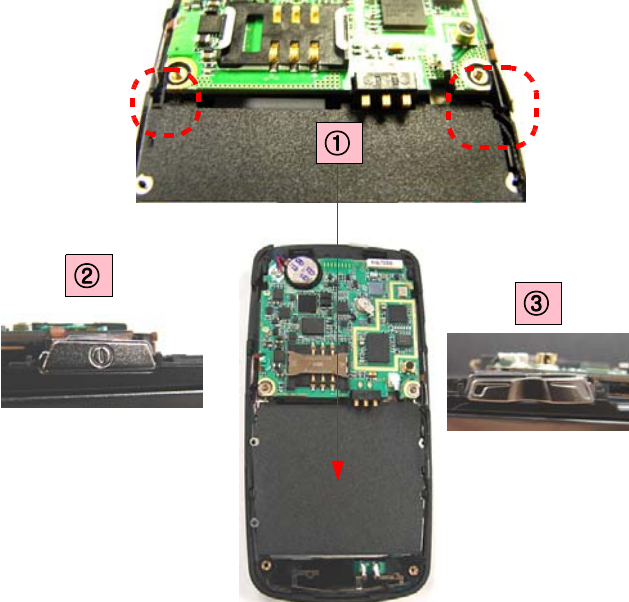

1) Put the SLIDE & 3*4KEY Connector at①②

<p>12</p> 	<p>13</p> 
<p>1) LOCK right side of the PBA 2) LOCK left side of the PBA 3) Attach the MOTOR 4)&5) Attach the POWER/VOLUME KEY</p> <p>* Caution</p> <p>1) When you slide up and down FRONT, keep the F-PCB suitably for normal operation</p>	<p>1) Put a CABLE CONNECTOR of the INTENNA 2) Attach the fixing sheet TAPE</p> <p>Part Code: GH42-01227A INTENNA Part Code: GH74-21856A,GH74-32855A Part Code: GH39-00794AINTENNA CABLE</p>
<p>14</p> 	<p>15</p> 
<p>1) Assemble the CONNECTOR of the INTENNA CABLE 2) Assemble the INTENNA</p>	<p>1) Attach the BLACK TAPE 2) Assemble the VOLUME & POWER KEY</p> <p>Part Code: GH74-30527A BLACK LABEL Part Code: GH72-38003A POWER KEY Part Code: GH72-38004A VOLUME</p>

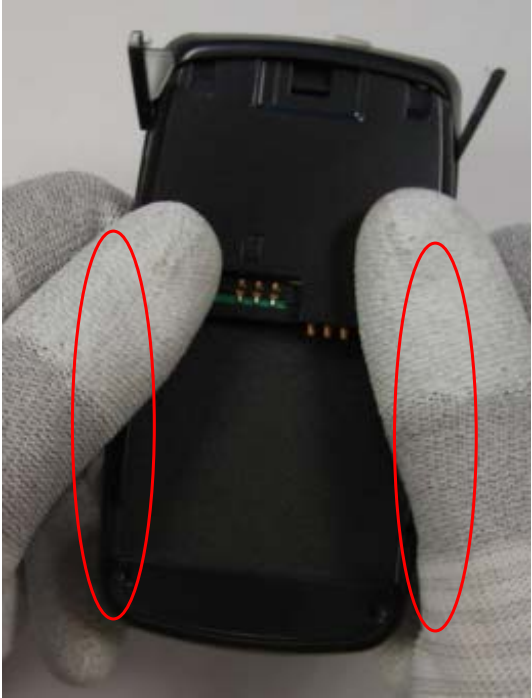
<p>16</p> 	<p>17</p> 
<p>1) LOCK upside of the REAR LOCKER and LOCK down the REAR Part Code: GH97-07139A REAR</p>	<p>1) While Pressing to inside, LOCK the REAR 2) Screw 4 Point of the SCREW Part Code: 6001-001479 SCREW</p>

<p>18</p> 	<p>19</p> 
<p>1) Location of 2.4" LCD Put 2.4" LCD MODULE on the REAR COVER. * caution Insert F-PCB into the hall of REAR COVER.</p>	<p>1) Attachment of MAIN WINDOW Attach MAIN WINDOW following the picture.</p>
<p>20</p> 	<p>21</p> 
<p>1) Attachment of Gasket Attach two gasket following the picture.</p>	<p>1) Attachment of Tape Attach two tape following the picture.</p>

<p>22</p> 	<p>23</p> 
<p>1) Assembly of INTENNA Positioning the Intenna on the REAR COVER, tighten the SCREW.</p>	<p>1) Attachment of 1.5" LCD Removing the vinyl on the back of 1.5" LCD MODULE, attach the module on the SHIELD COVER.</p>
<p>24</p> 	<p>25</p> 
<p>1) Attachment of SUB WINDOW Attach the SUB WINDOW on the front cover.</p>	<p>1) Location of NAVI KEY Locate NAVI KEY on the FRONT COVER. * caution Locating the NAVI KEY, watch the twelve of RIB.</p>

26

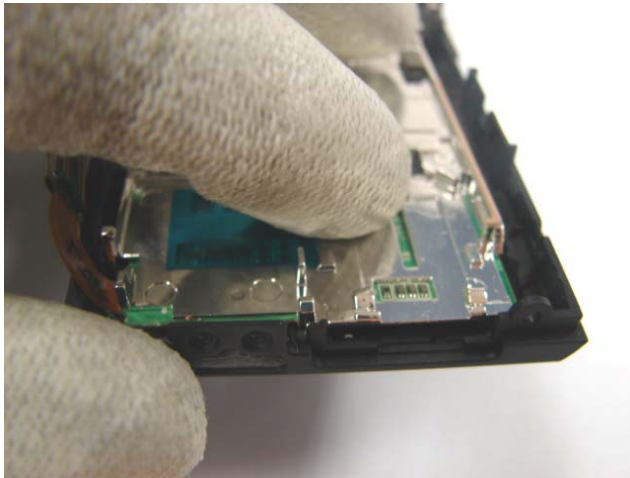

1) Location of SHIELD COVER.
Locate shield cover on the front cover from the top to the lower.

27

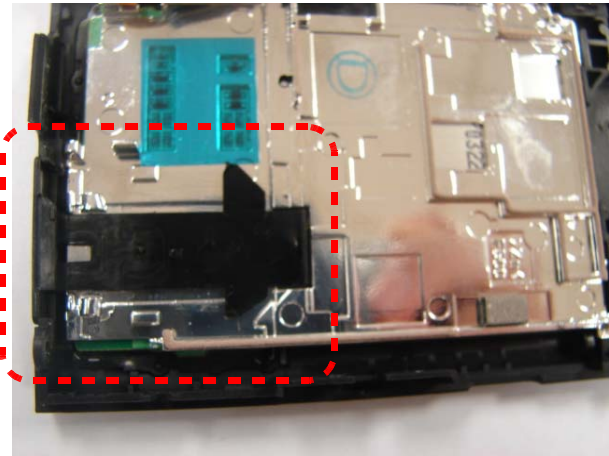

1) Location of SIM COVER
Locate the SIM COVER on the SHIELD COVER following the picture.

28



1) Rotating the HINGE
Rotate the HINGE before positioning the SWING assembly.

29

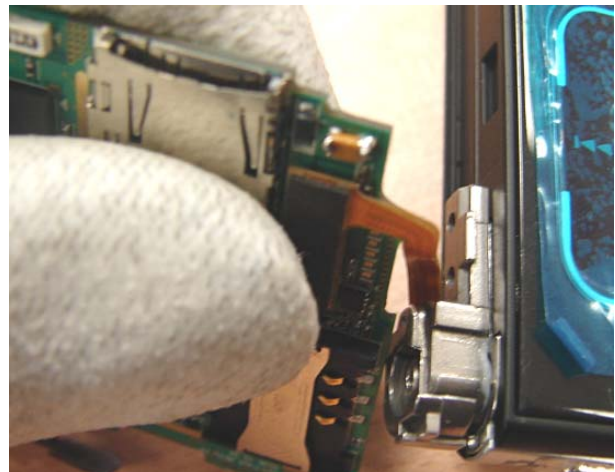

1) Assembly of CON TO CON CONNECTOR
Insert CON TO CON CONNECTOR to PBA following the picture.

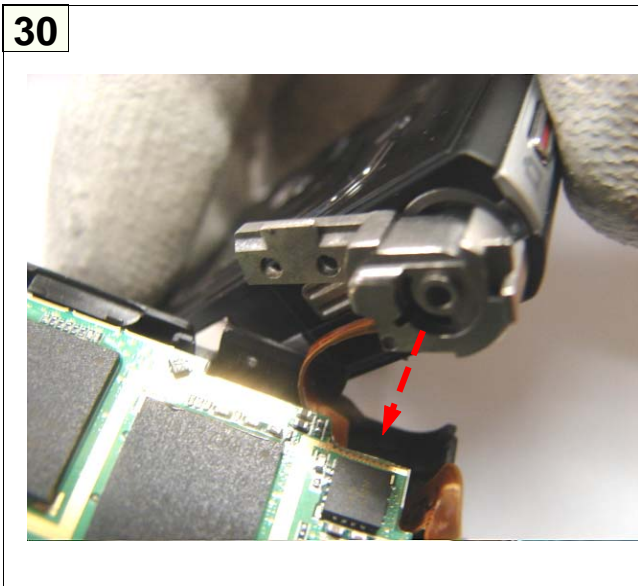

1) Assembly of HINGE
After locating the PBA, locate the SWING HINGE on the FRONT COVER.

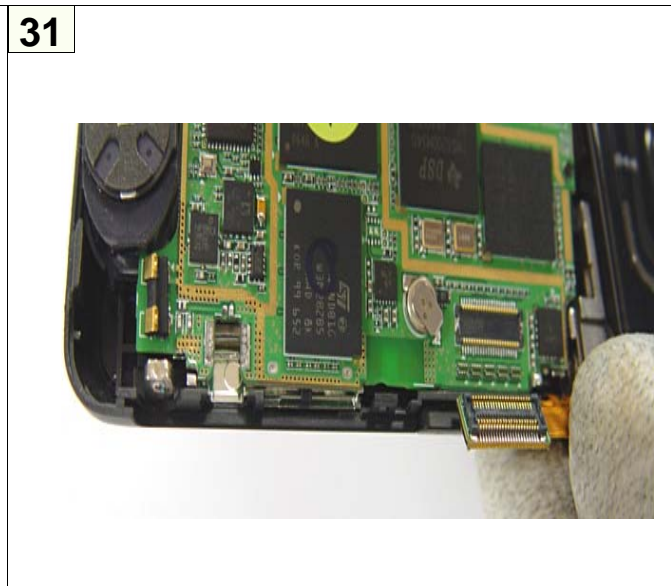

1) Location of PBA
Locate the PBA by the hook of FRONT COVER.

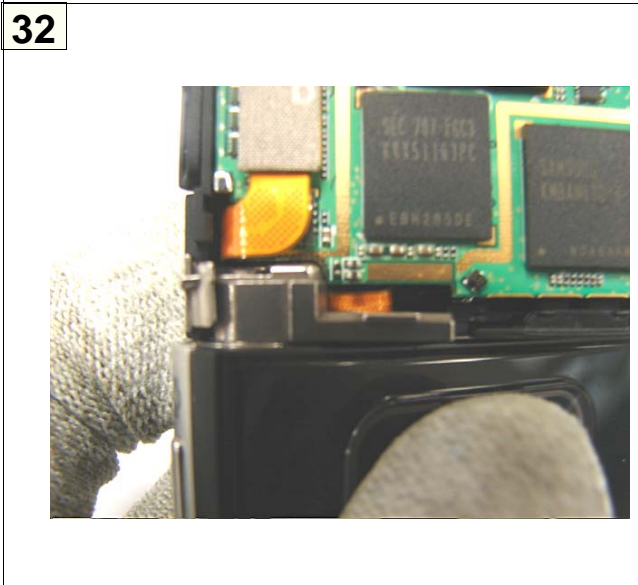

1) Arrangement of SWING on the FRONT COVER
Arrange the SWING PART on the FRONT COVER.



1) Arrangement of SWING on the FRONT COVER
Arrange PBA on the FRONT COVER.

34



1) Location of SPEAKER
Locate SPEAKER on the FRONT COVER HOLE.

35



1) Assembly of SCREW
Tighten a screw on the right upper side of PBA.

*** caution**

When tightening, Be careful of harm of surrounding chips.

36



1) Assembly of SUB LCD CONNECTOR.
Insert the SUB LCD CONNECTOR into the socket on the left side of PBA.

37

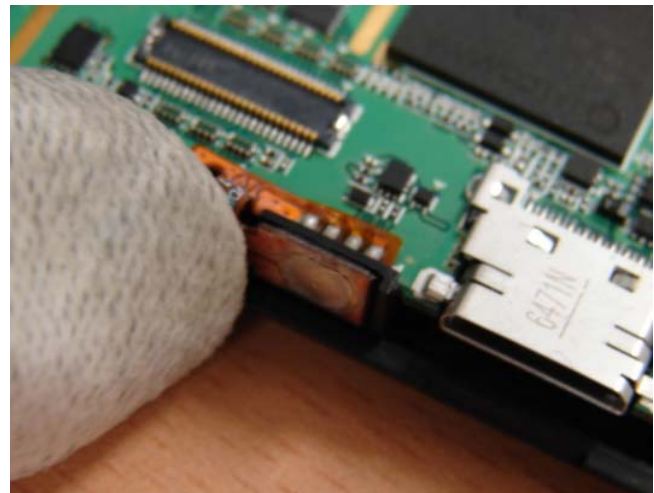

1) Attachment of VOLUME KEY
Attach the VOLUME KEY F-PCB on the front cover.

<p>38</p> 	<p>39</p> 
<p>1) Assembly of 2MEGA CAMERA Inset 2MEGA CAMERA on the socket of the right and upper side fo PBA.</p>	<p>1) Assembly of Left SIDE BELT Insert Left SIDE BELT. * caution When inserting, locate HOLD KEY on the HOLD SWITCH exactly.</p>
<p>40</p>  	
<p>1) Assembly of right SIDE BELT Insert right SIDE BELT from the top to the lower. * caution When inserting, locate exactly on each hook, easpecially the lower hook.</p>	

41

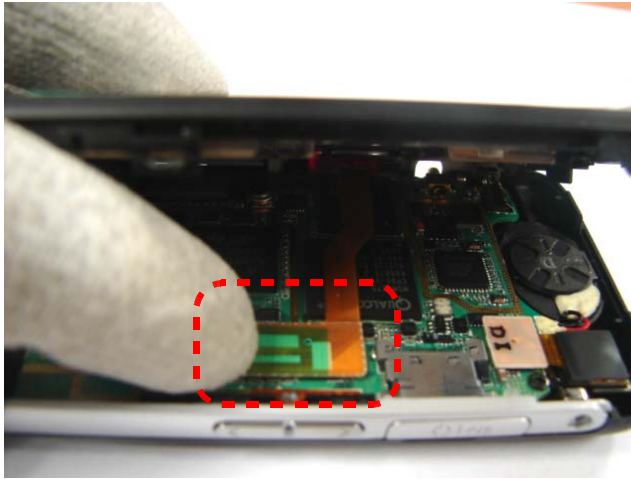

1) Insertion of 2.4" LCD CONNECTOR
Insert 2.4" CONNECTOR following the picture.

42



1) Assembly of REAR part
Assemble the rear part following the picture.

*** caution**

Assemble the locker from the upper to the lower, one by one.

43



1) Tightening the SCREW (Step 1)
Tighten the two screws following the picture.
(Notice the color of SCREW: SILVER 2EA)

44



1) Tightening the SCREW (Step 2)
Tighten the three screws following the picture.
(Notice the color of SCREW: SILVER 1, BLACK 2)

3. Flow Chart of Troubleshooting

3-1. Baseband

3-1-1. Power ON

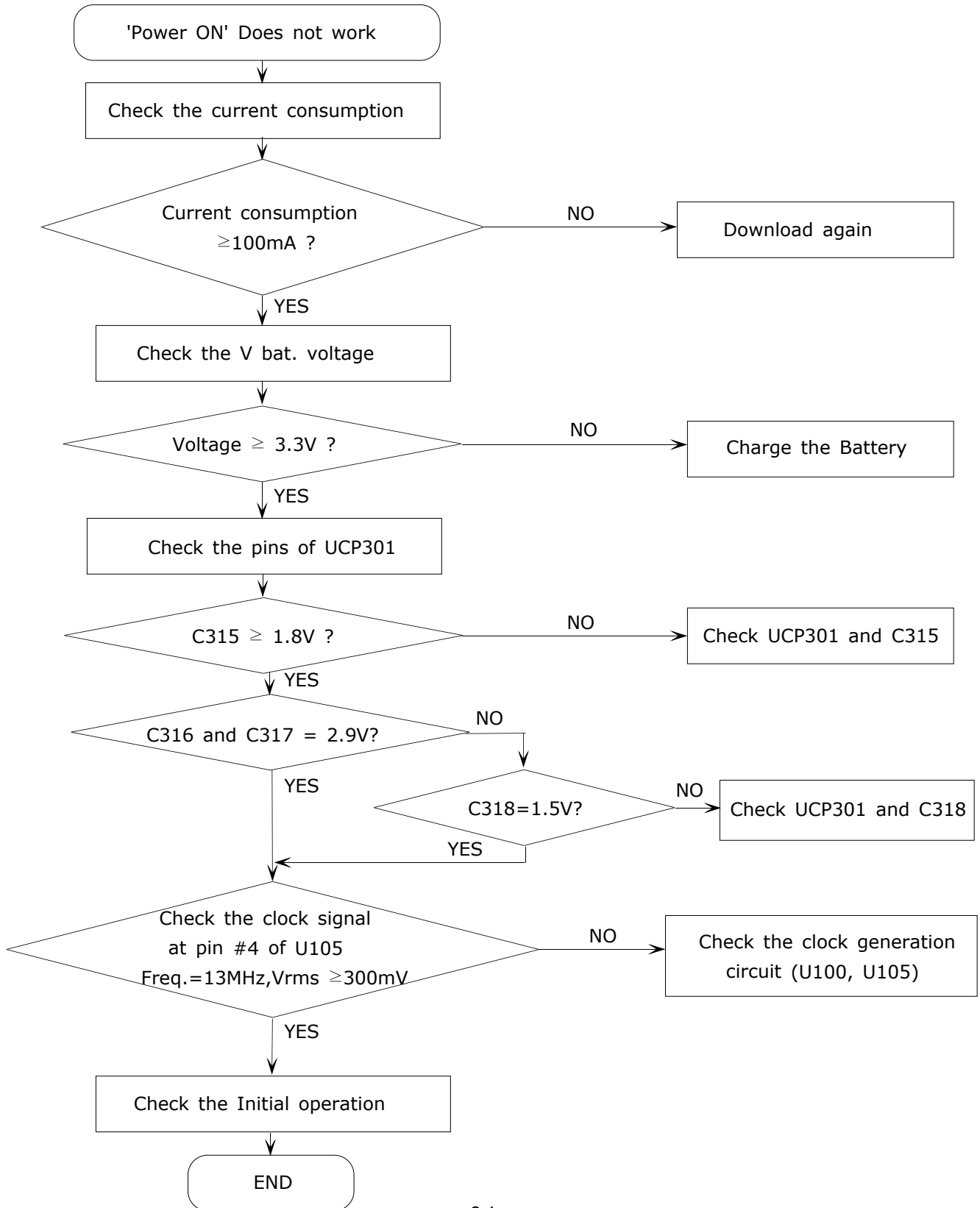

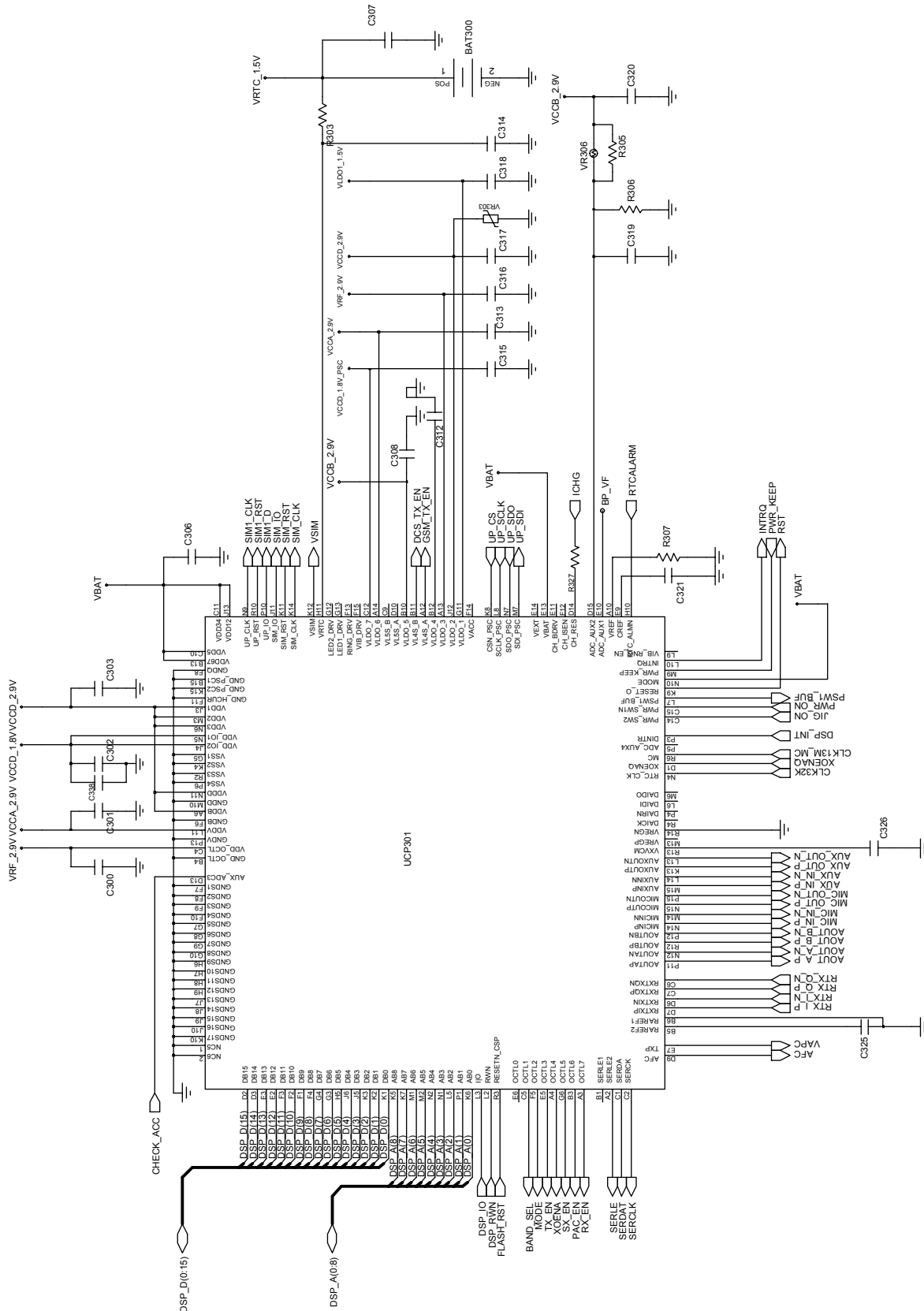

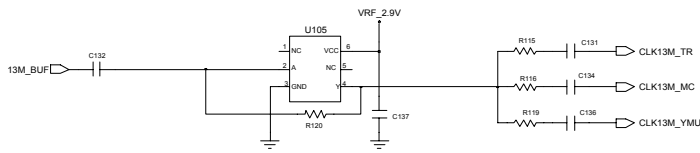
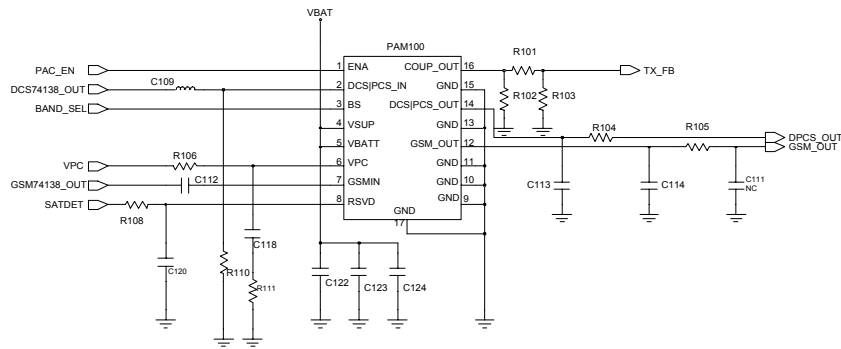

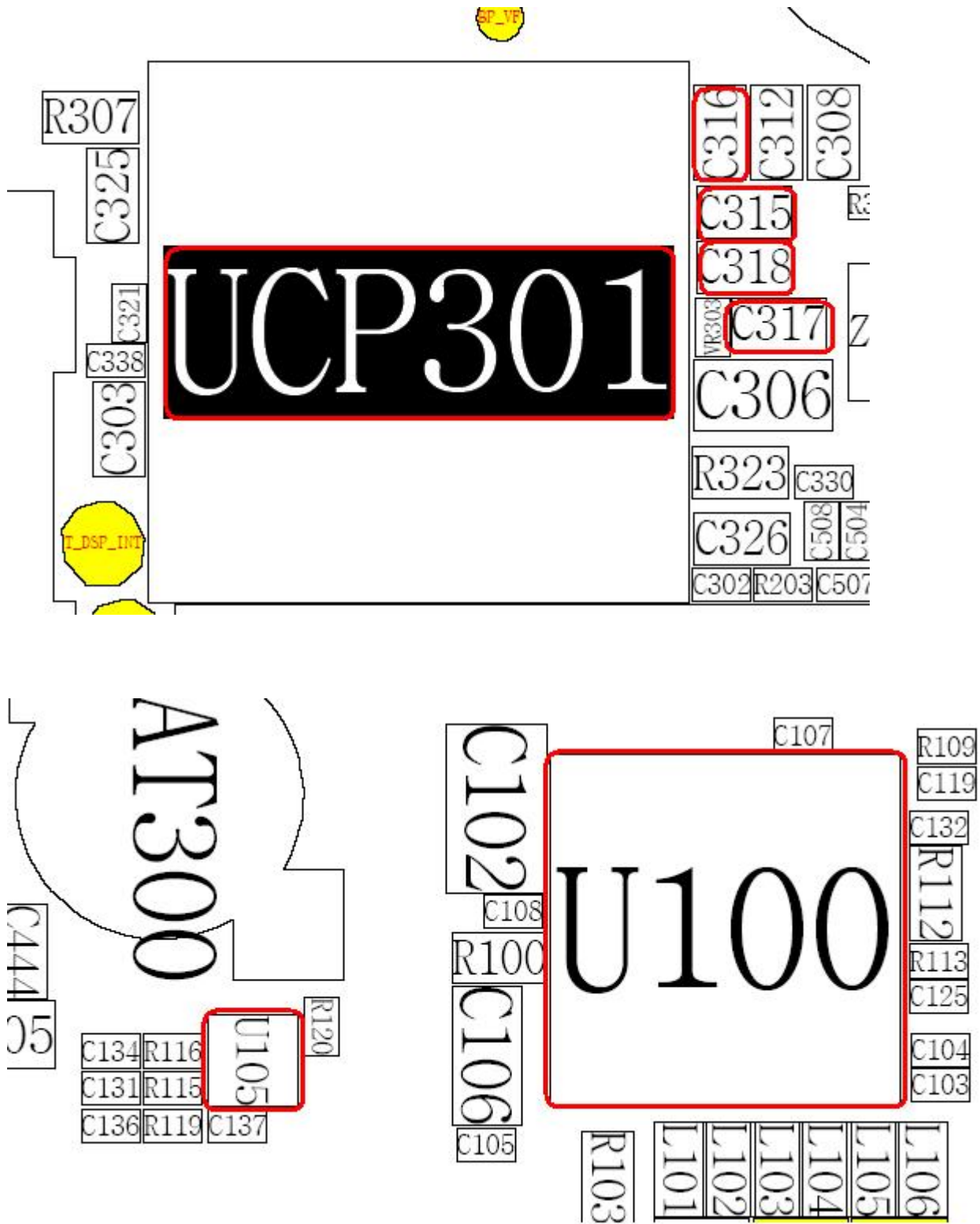

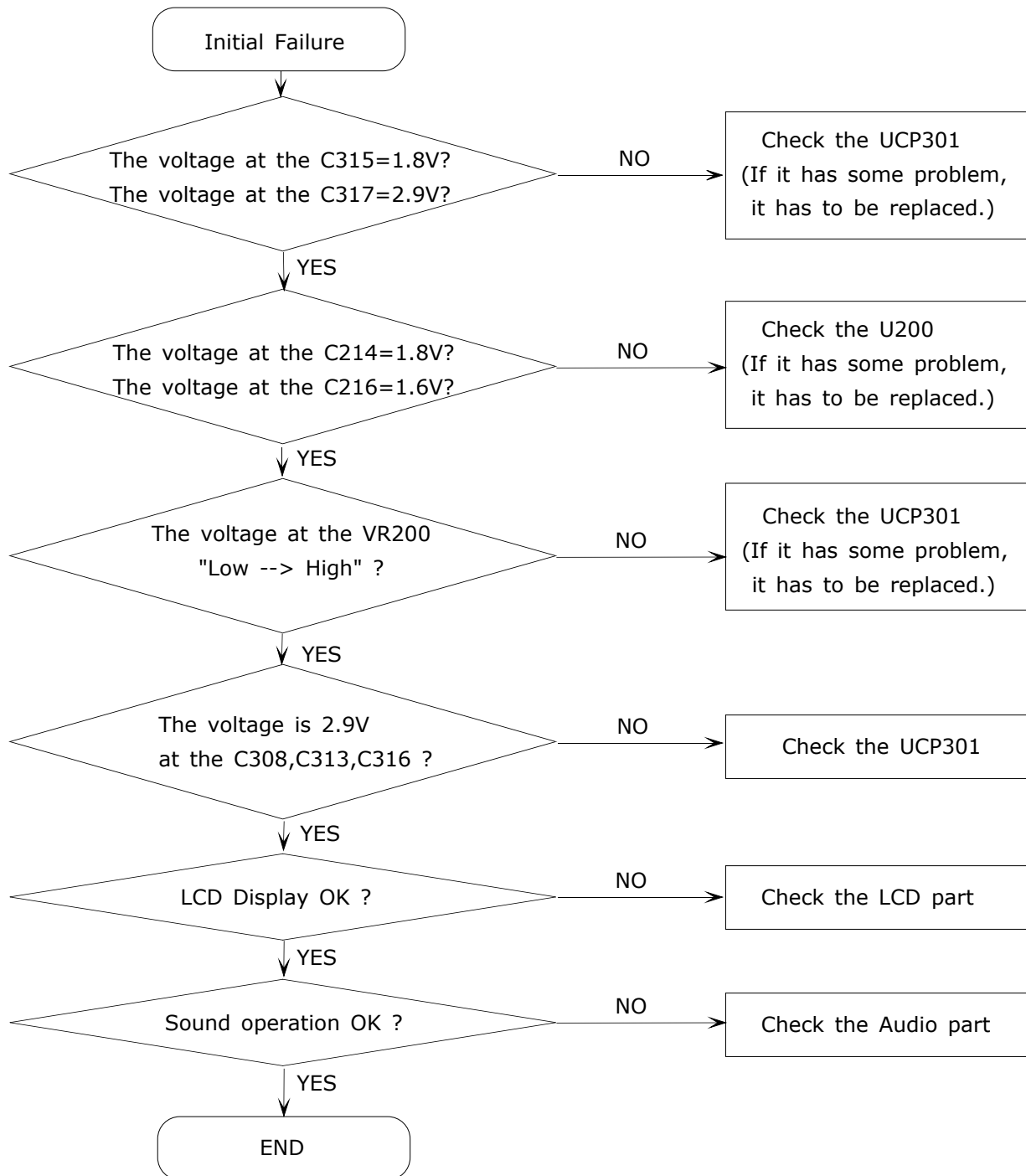
3-1-2. Initial

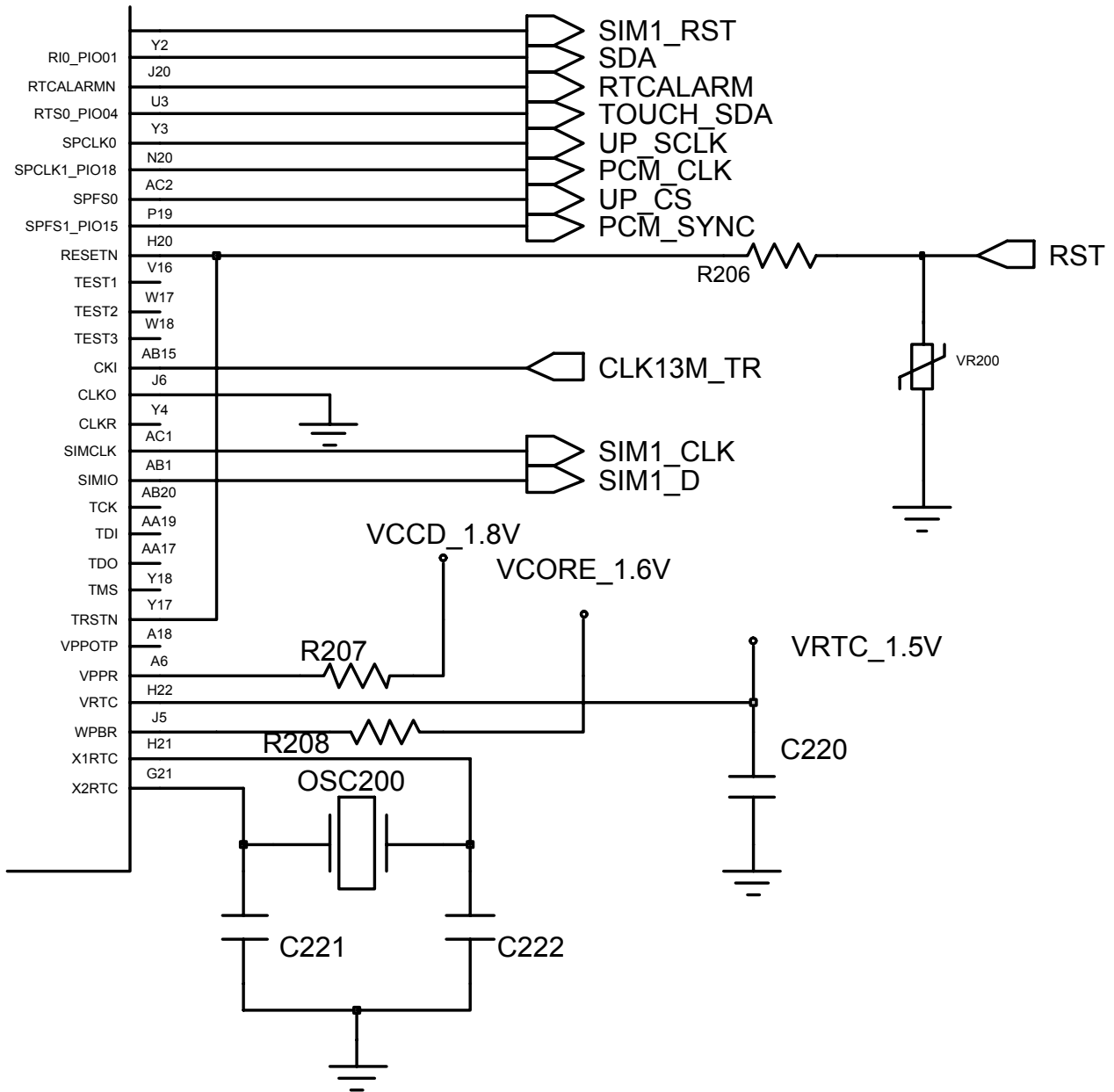

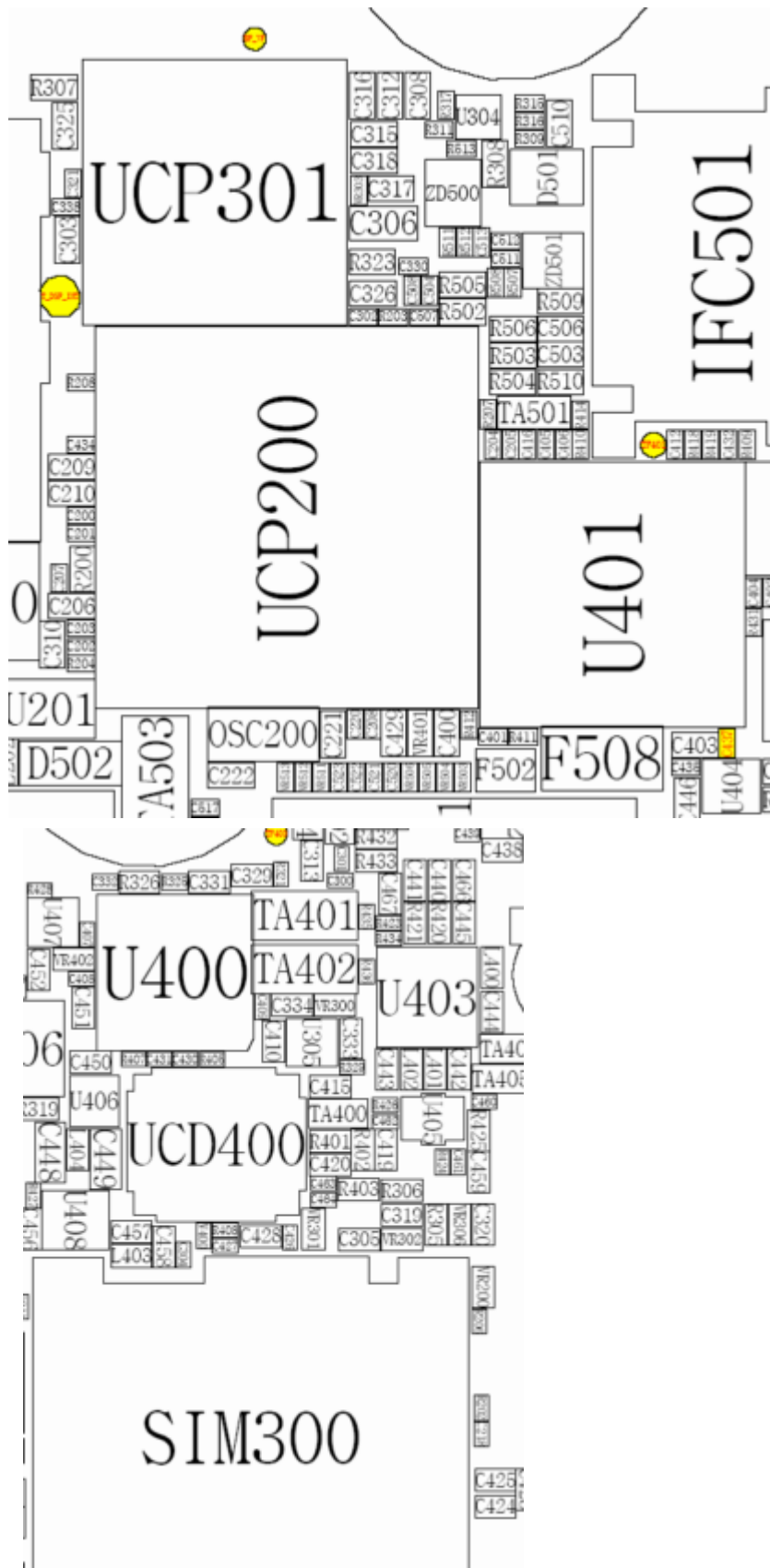

3-1-3. SIM Part

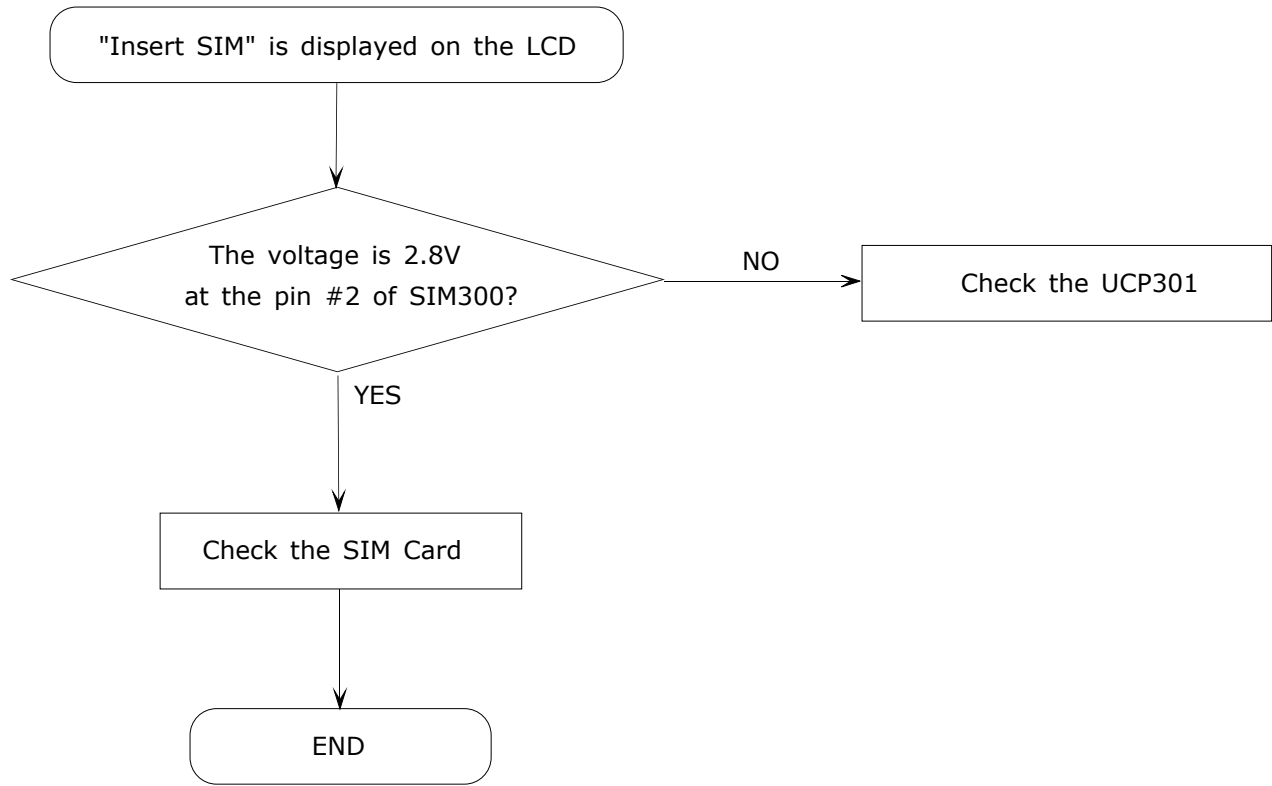

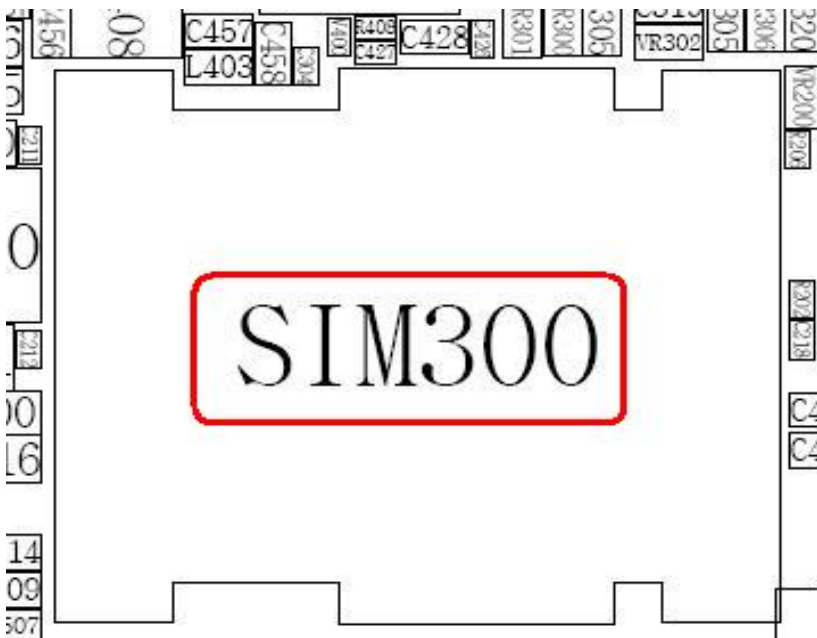
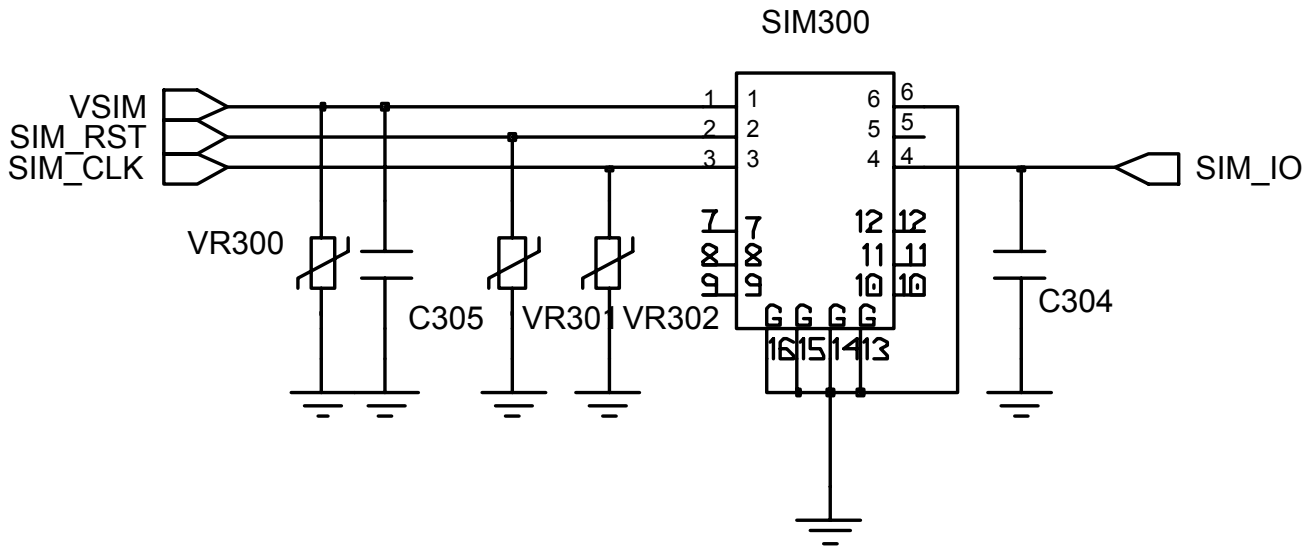

3-1-4 Charging Part

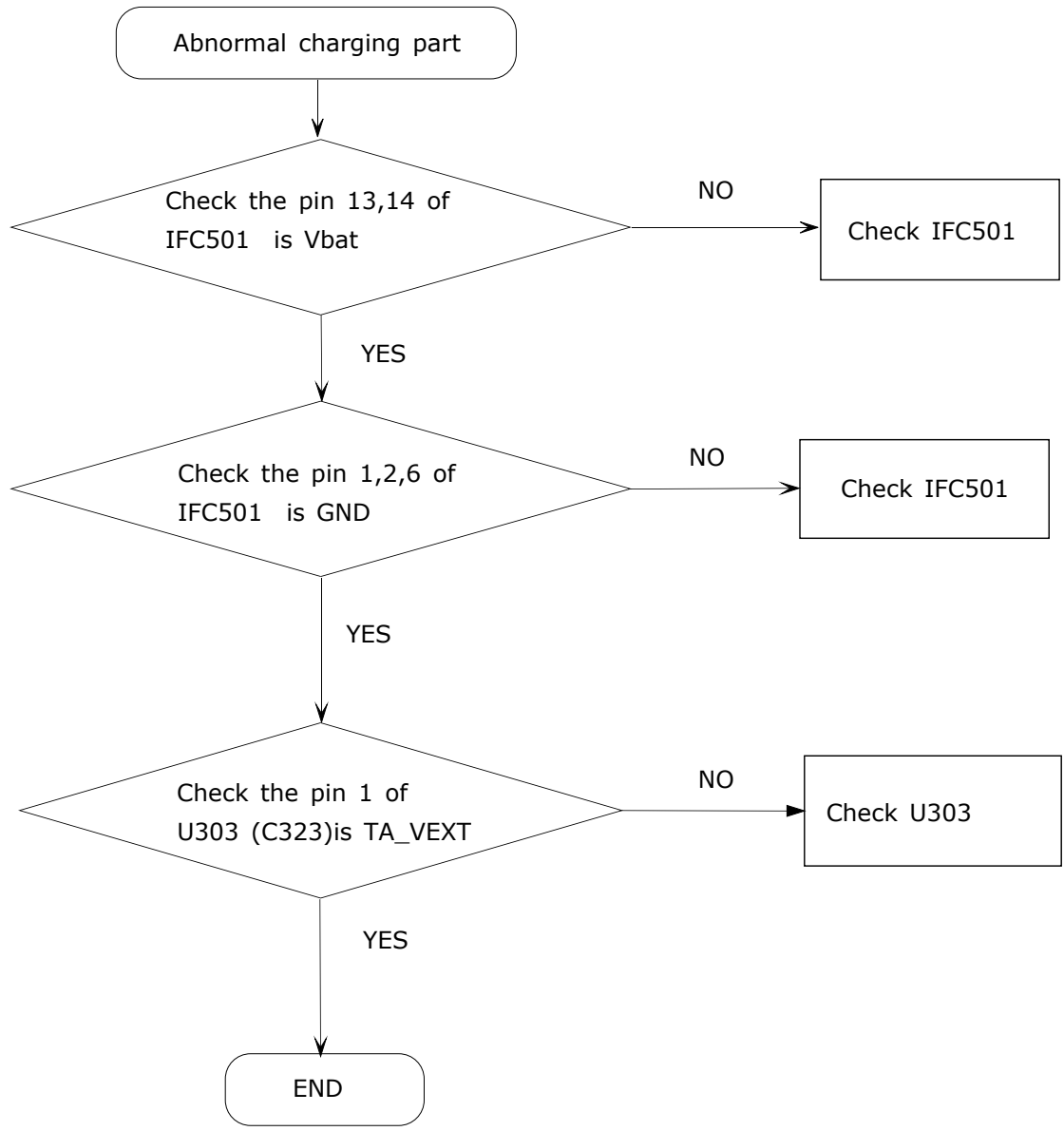

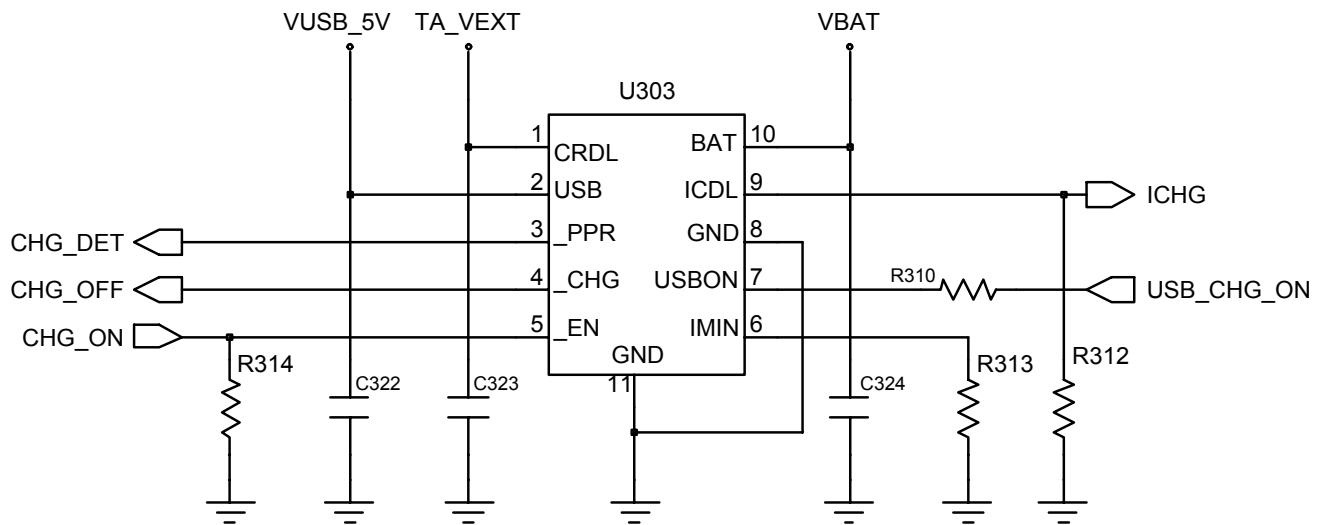
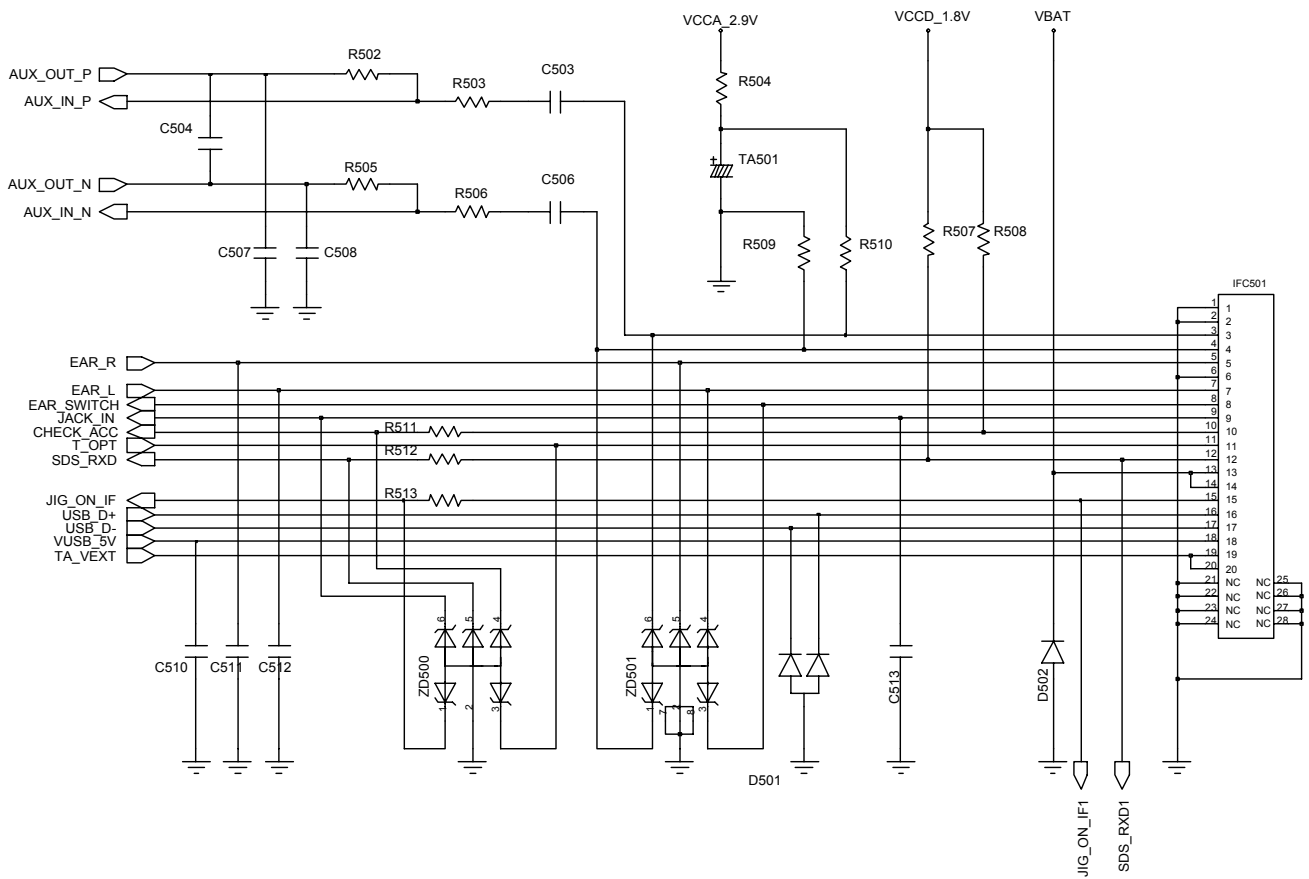

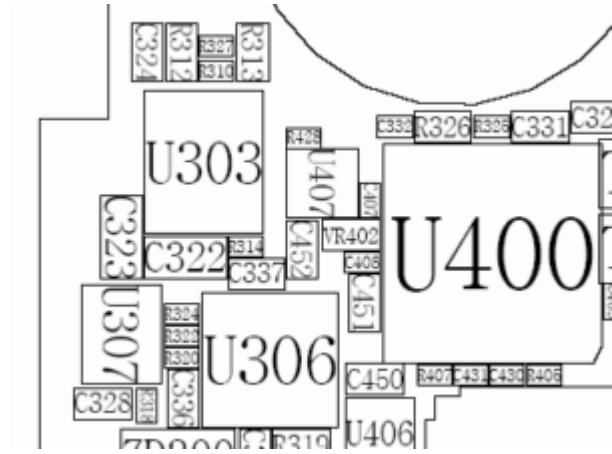
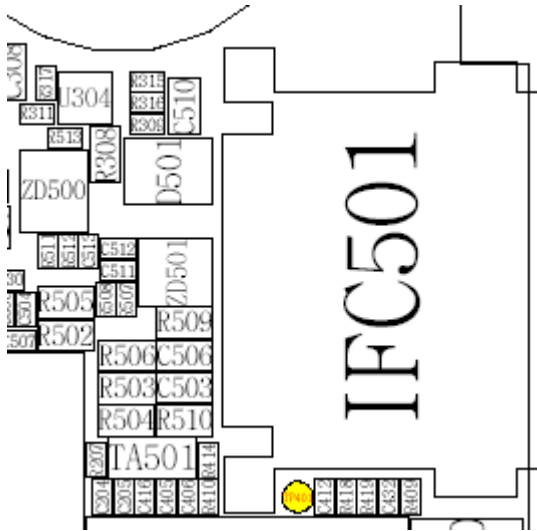

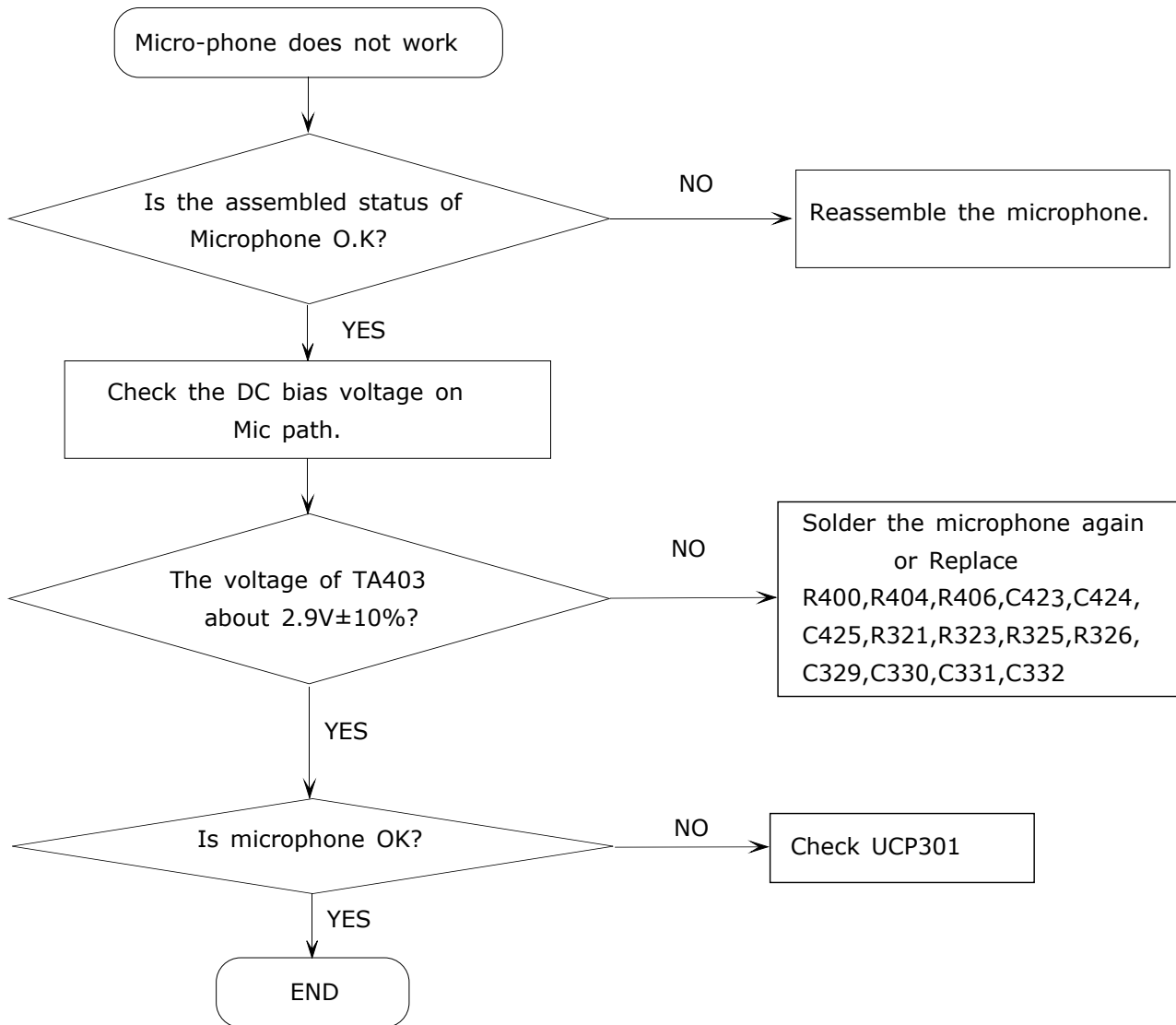
3-1-5. Microphone Part

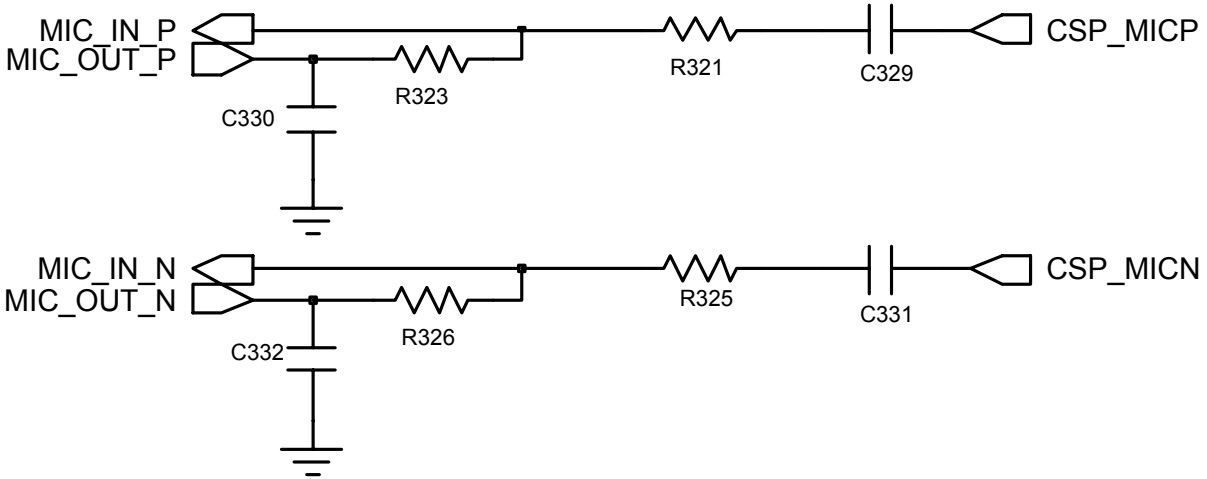
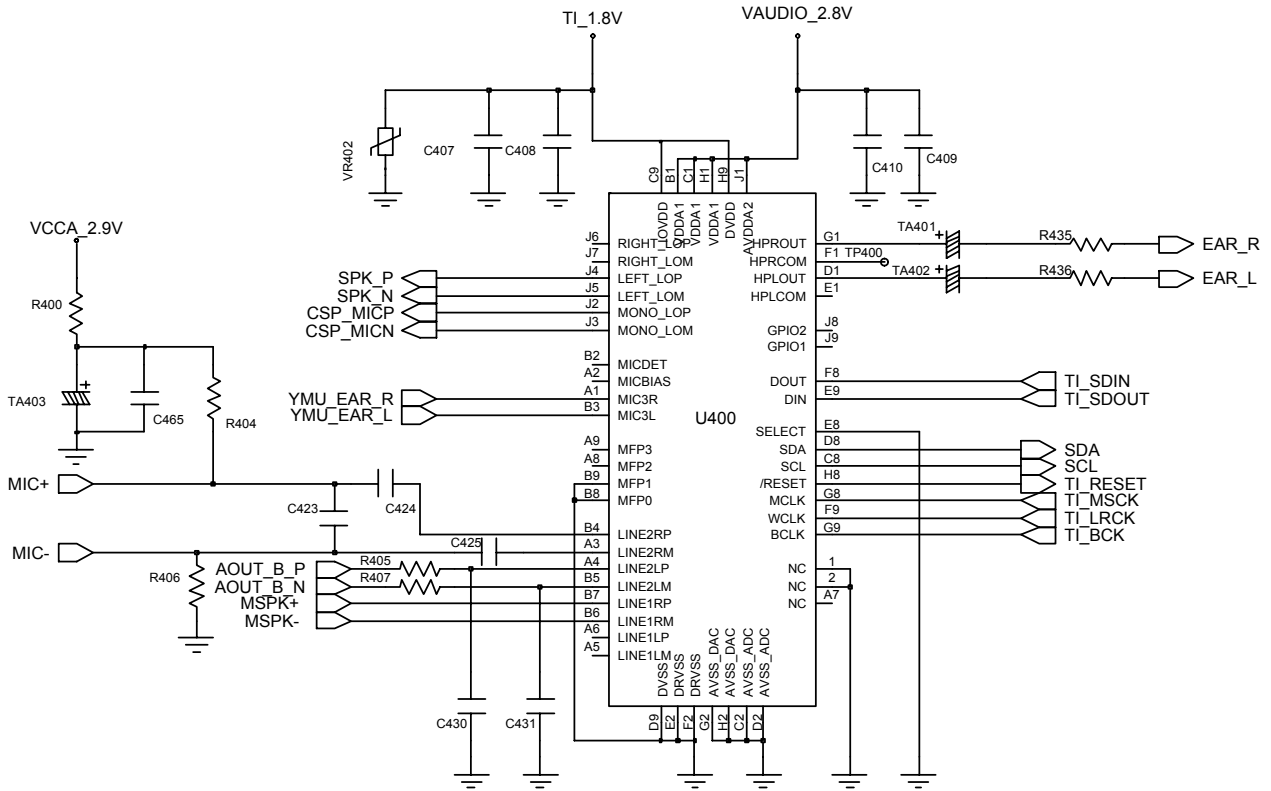

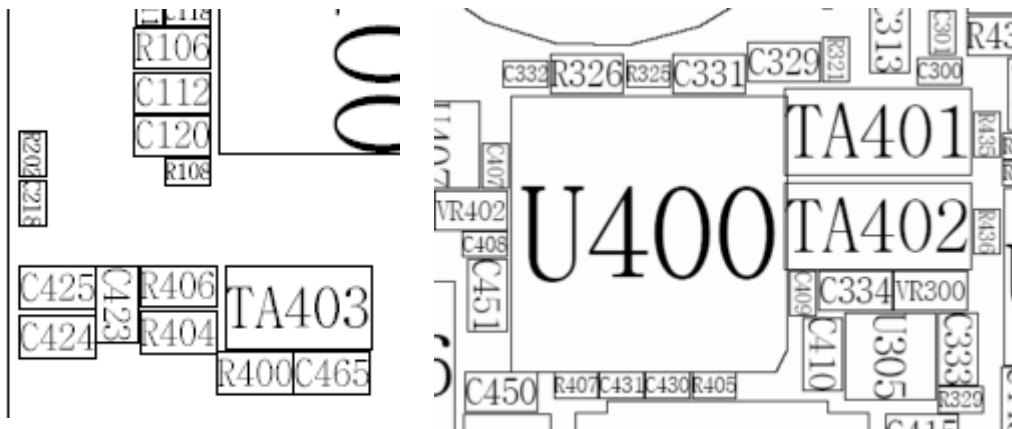

3-1-6. Audio Part

1) When you are calling

- Receiver

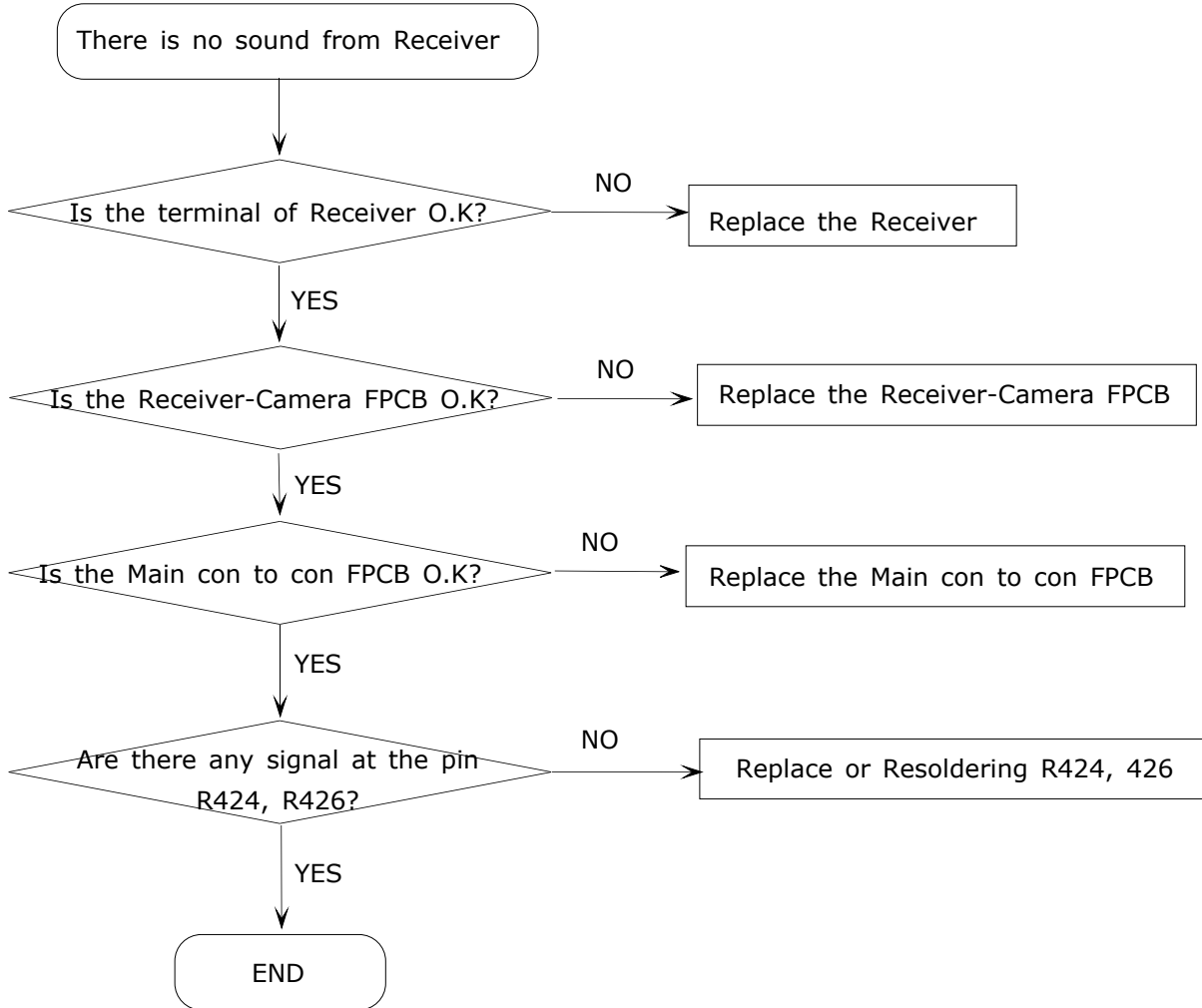

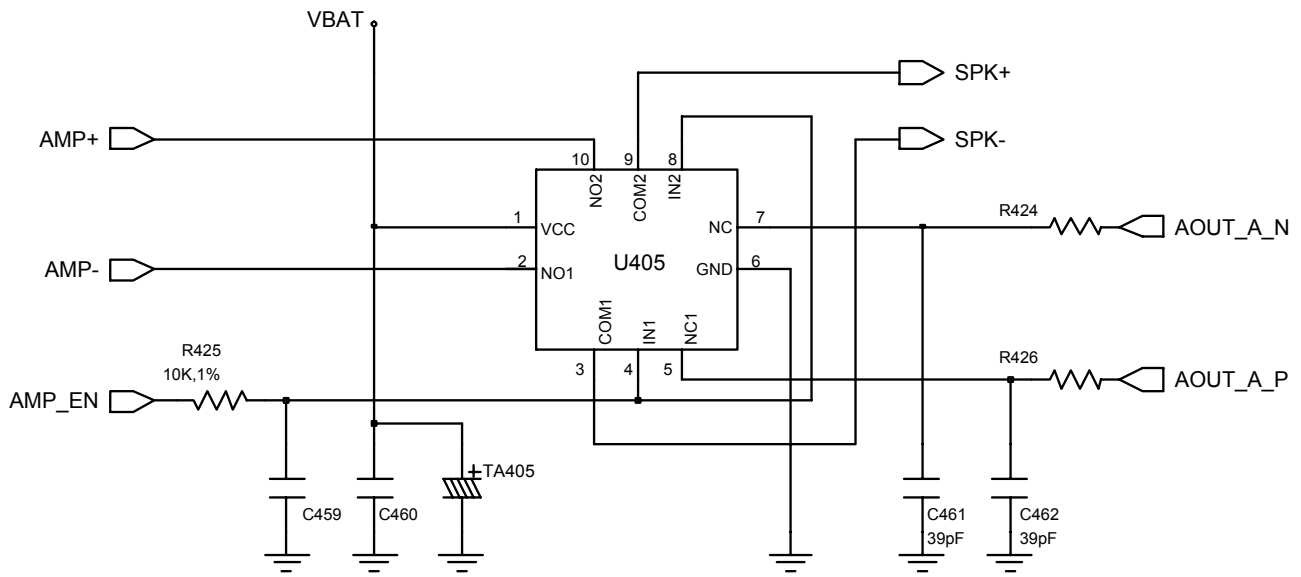

- Speaker

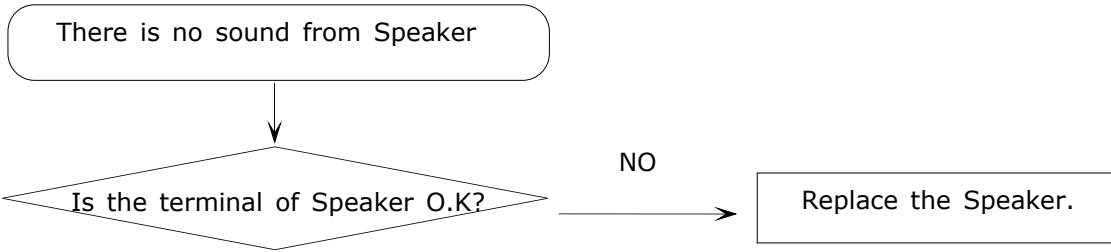

본 페이지 편집 불가능 합니다!
편집 가능하도록 해주세요.

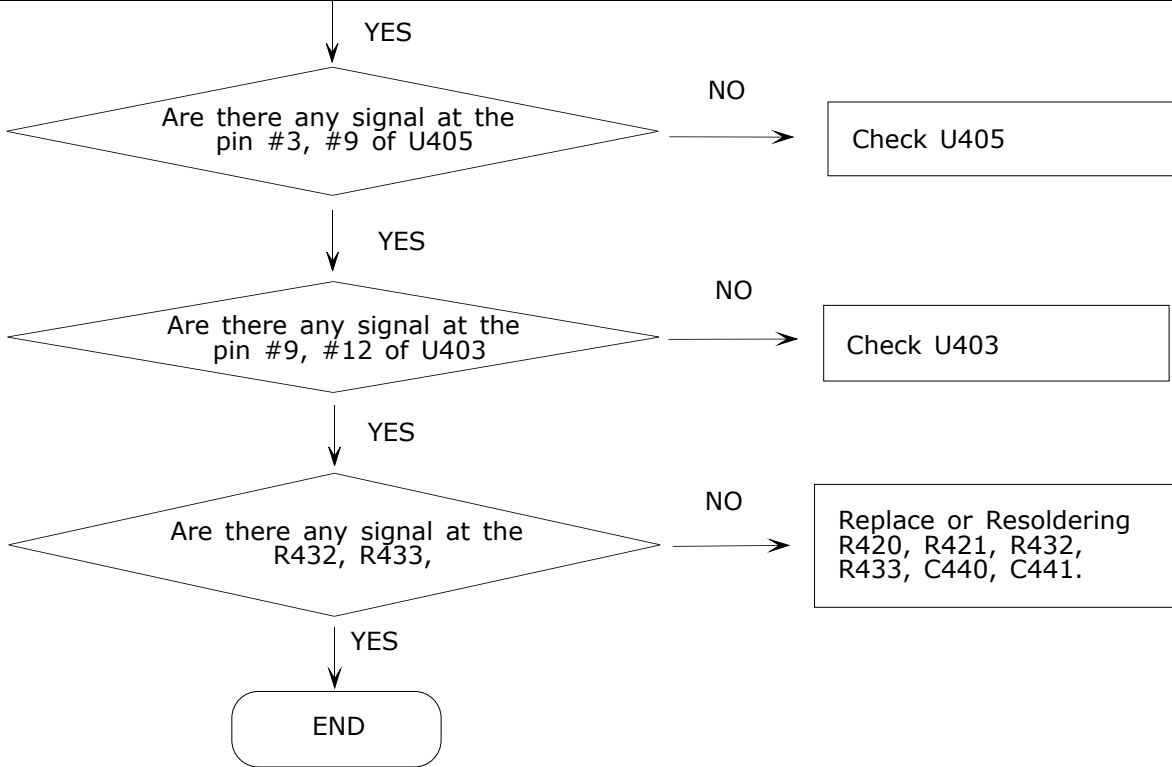

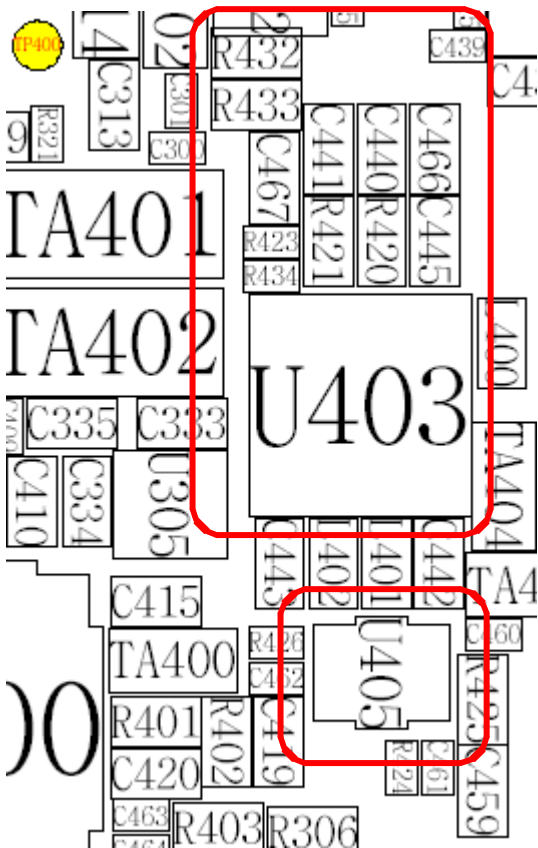
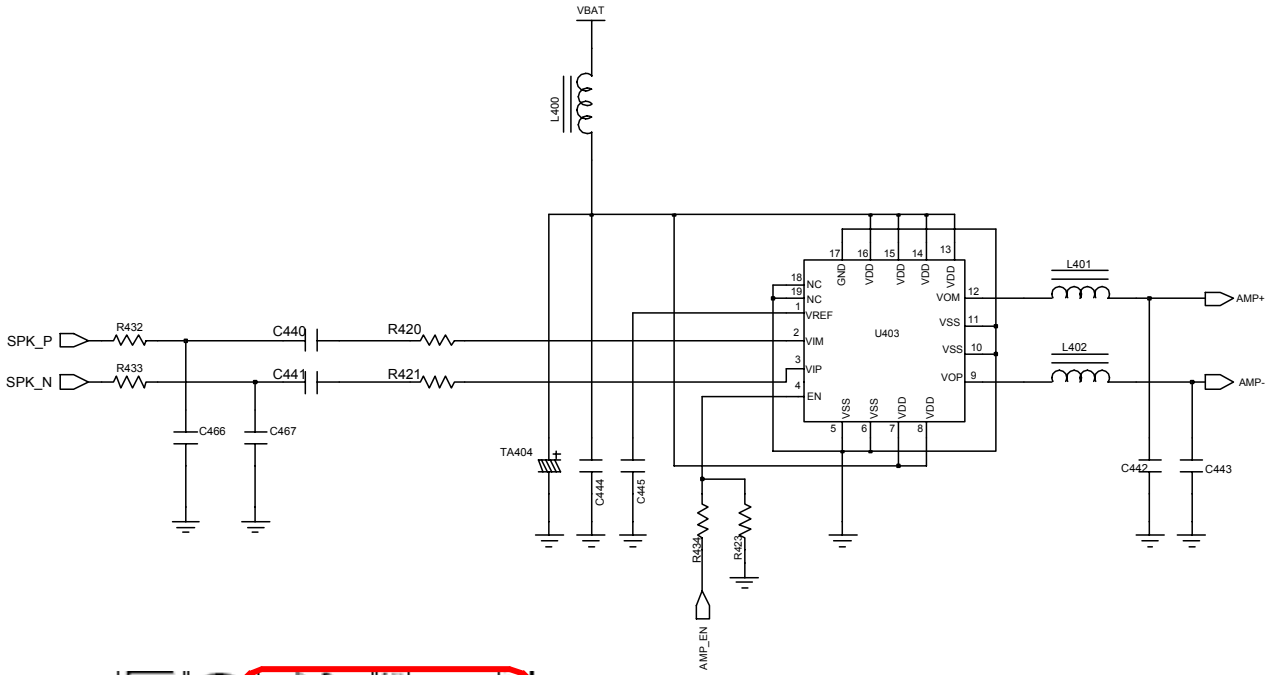

2) MP3 is not O.K.

There is no sound from Speaker

Is the terminal of Speaker O.K?

NO

Replace the Speaker

본 페이지 편집 불가능 합니다!
편집 가능하도록 해주세요.

Are there any signal at the
R432, R433, R420, R421

Check U400

YES

Are there any signal at the
pin #12, #9 of U403

NO

Check U403

YES

Are there any signal at the
L401, L402.

NO

Replace or Resoldering
L401, L402

YES

Are there any signal at the
pin #3, #9 of U405

NO

Replace or Resoldering
U405

YES

END

3) Melody is not O.K.

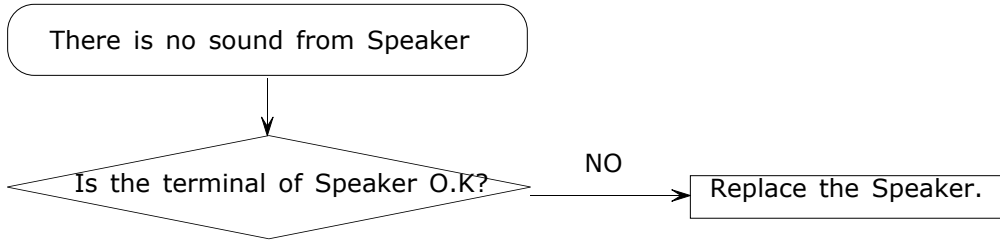

본 페이지 편집 불가능 합니다!
편집 가능하도록 해주세요.

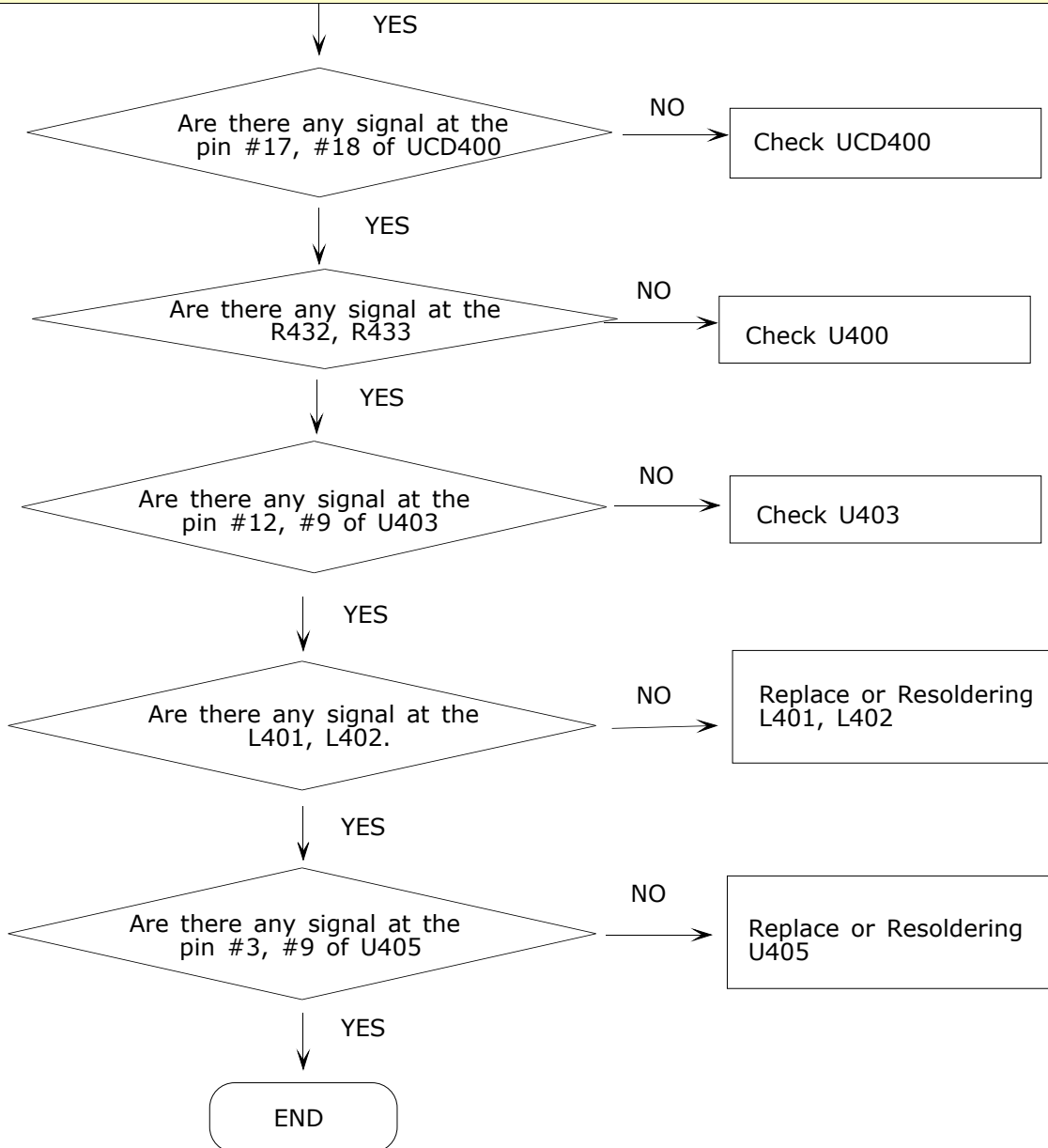

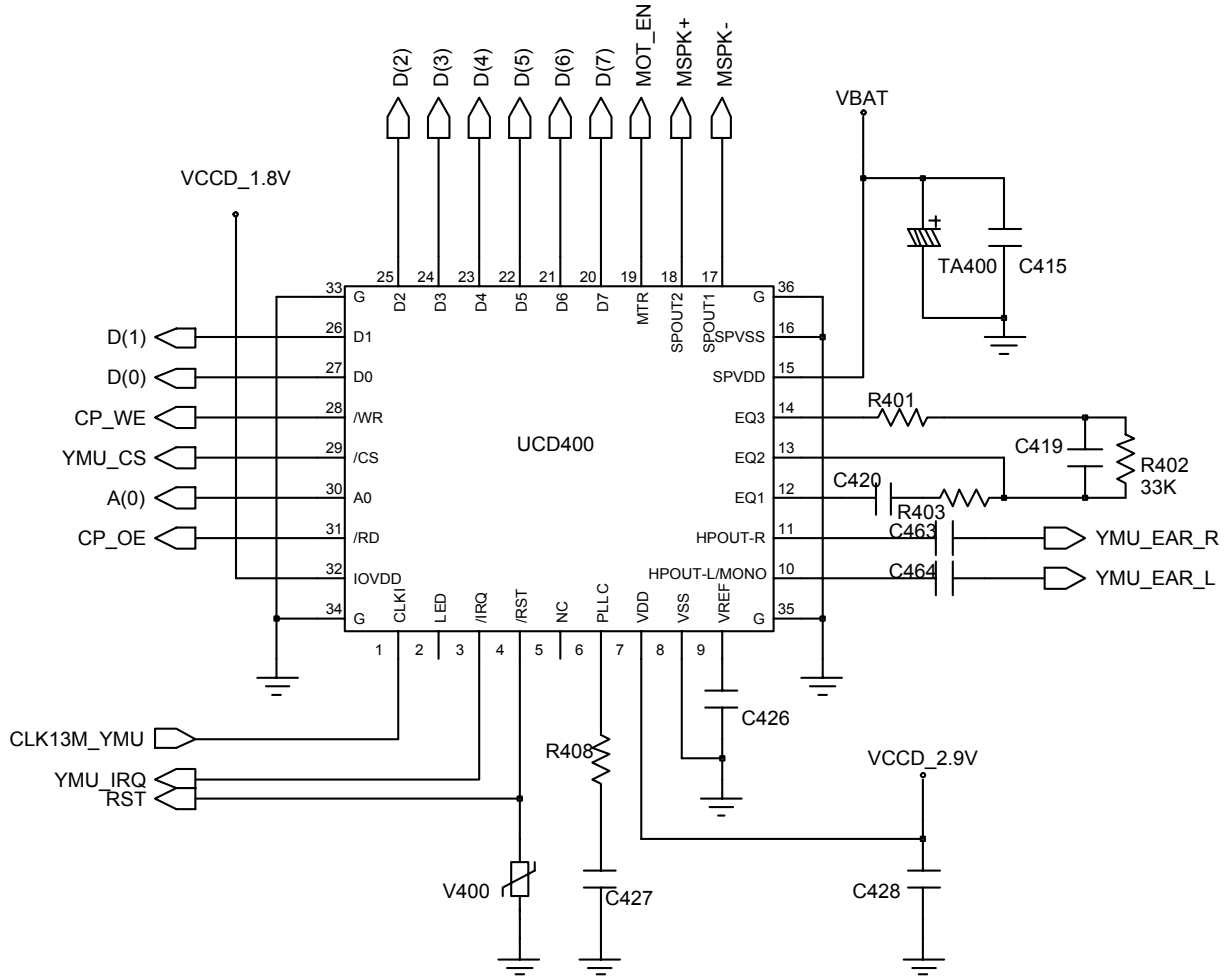

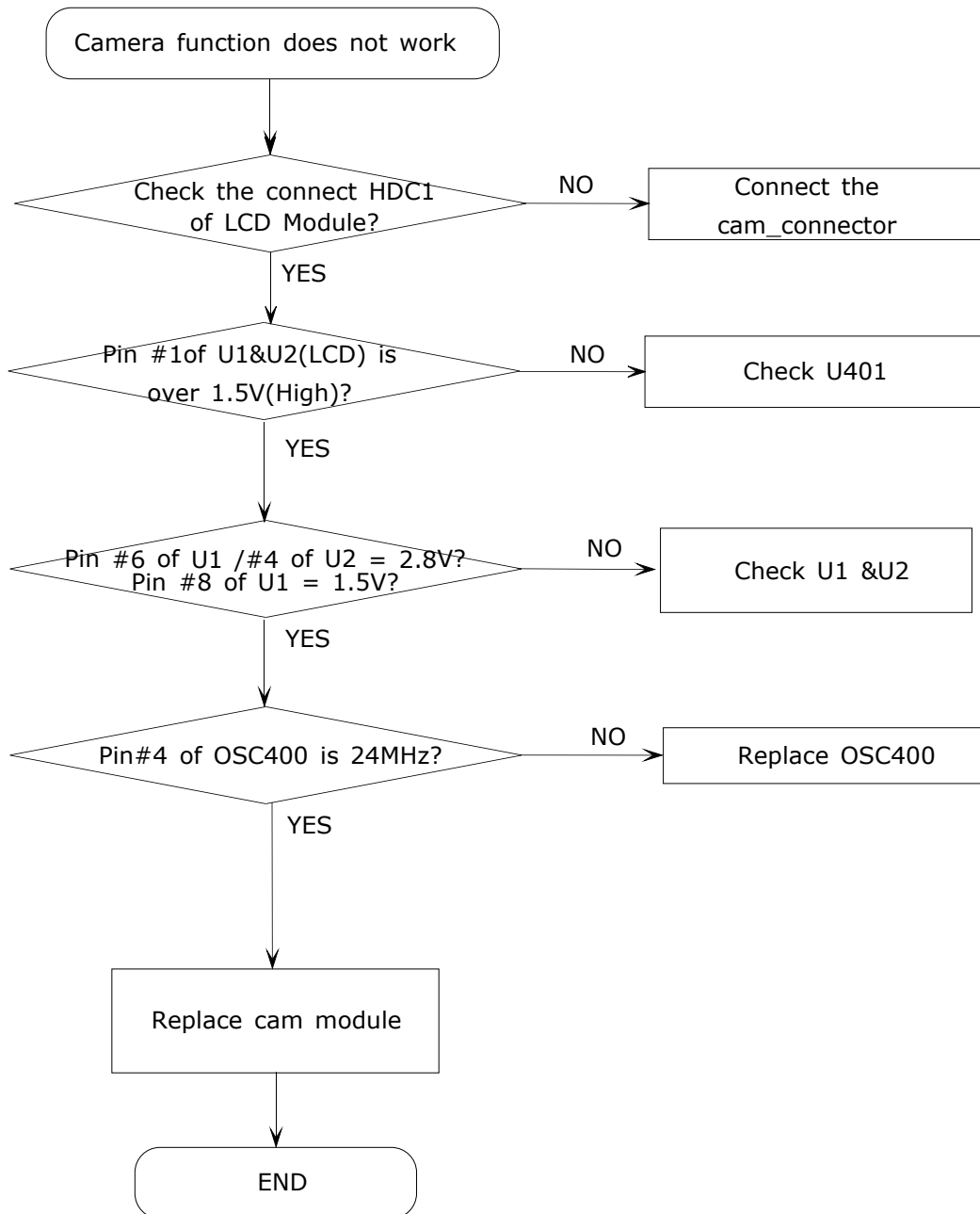
3-1-7. Camera Part

Flow Chart of Troubleshooting

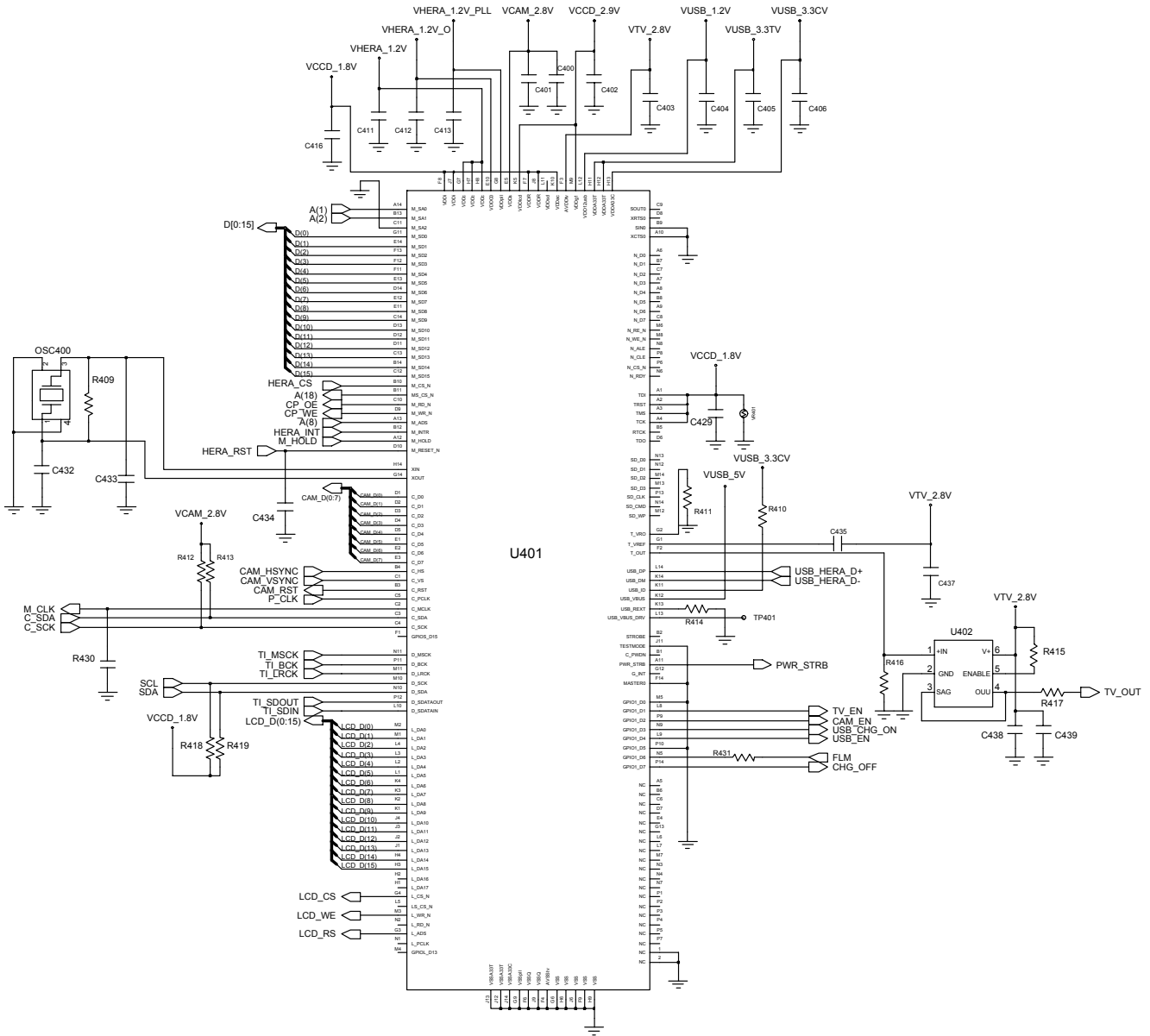

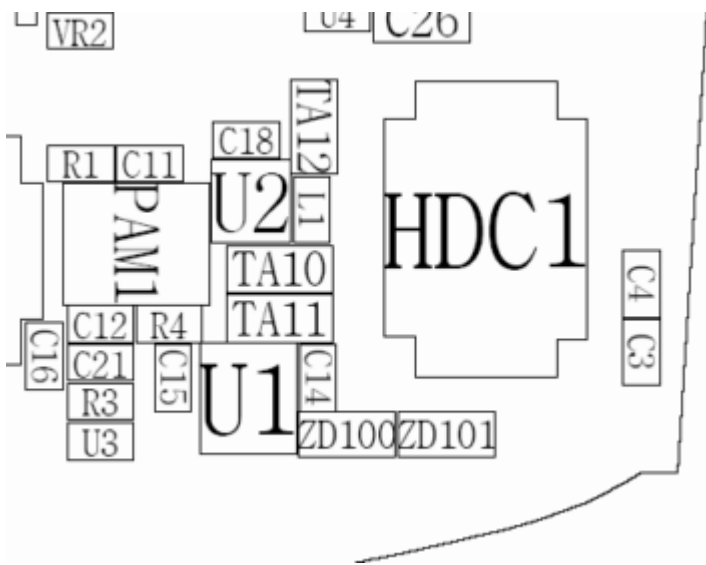
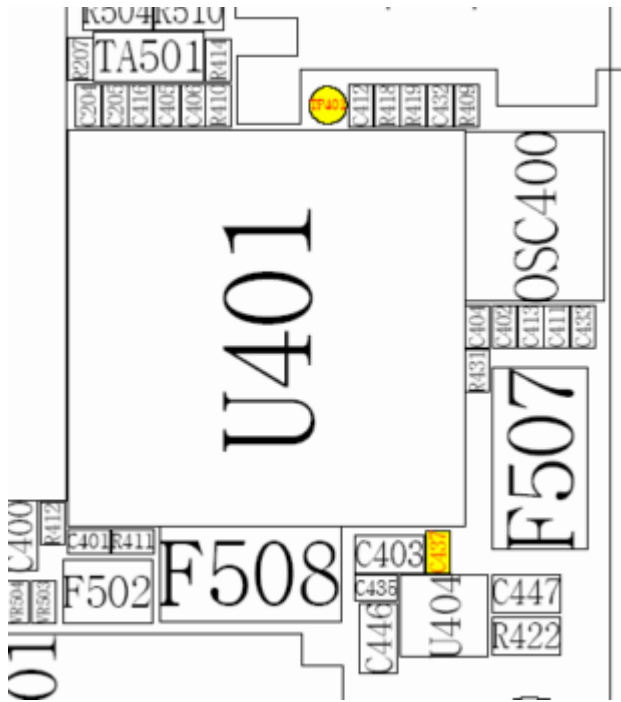

3-1-8. LCD Display

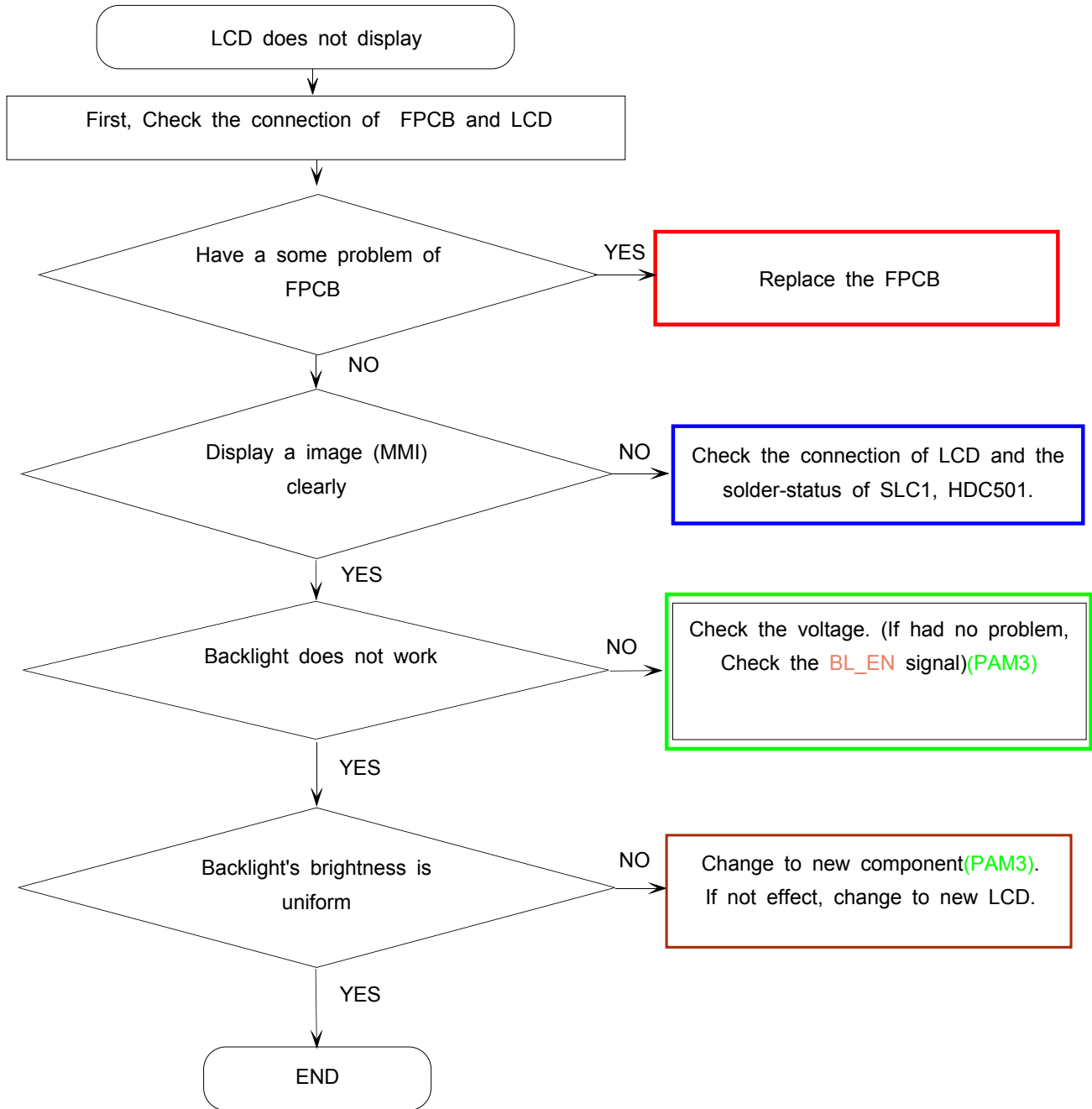

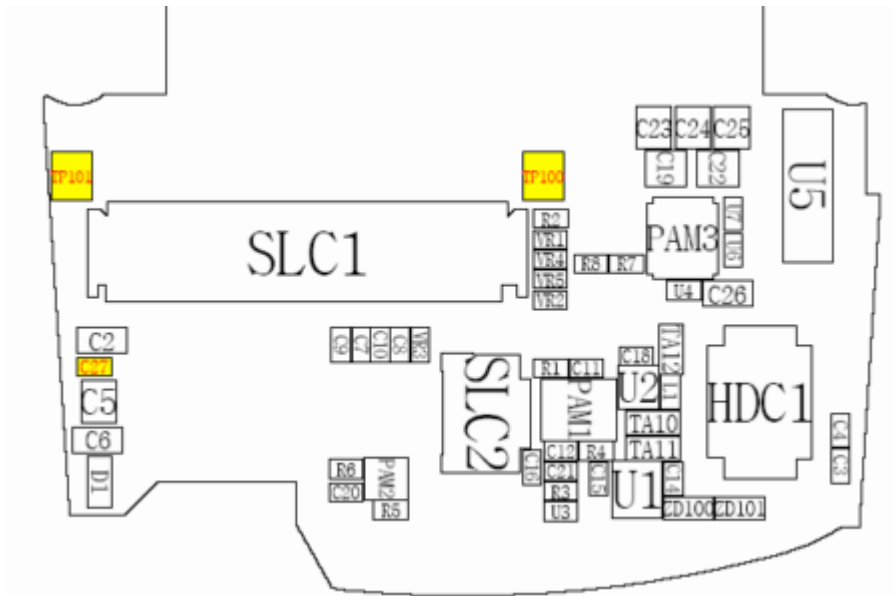
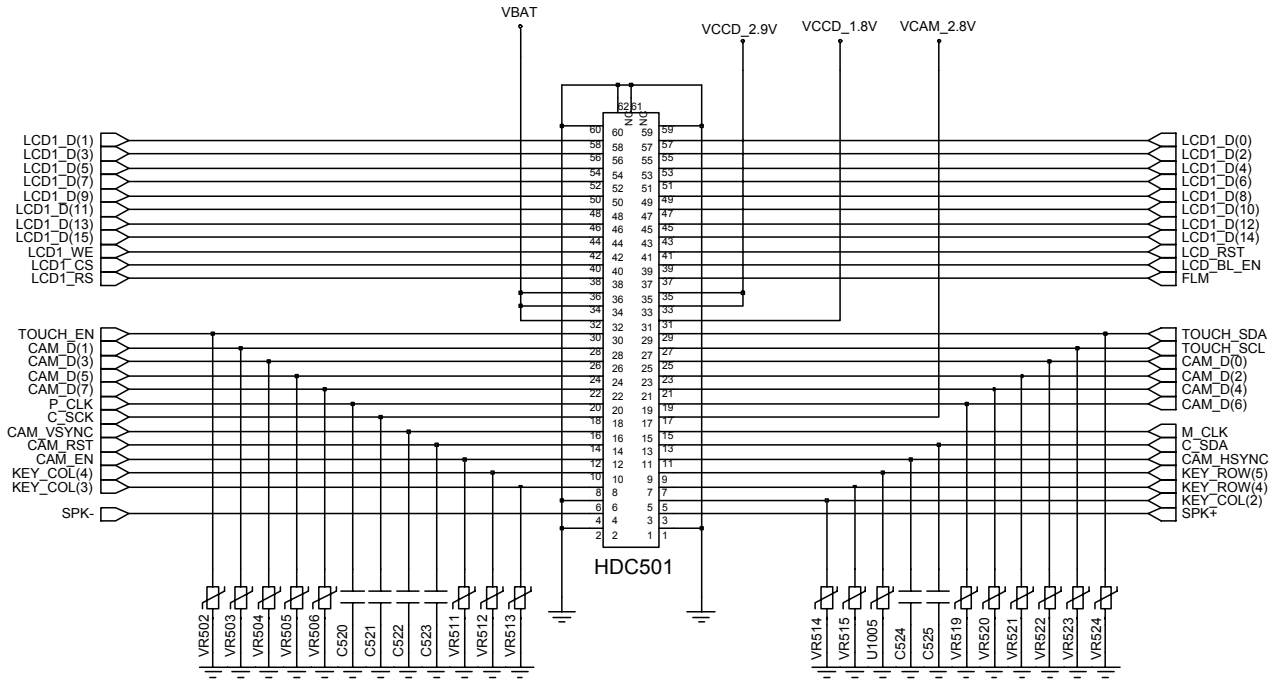

3-2.RF

3-2-1.GSM900 RX

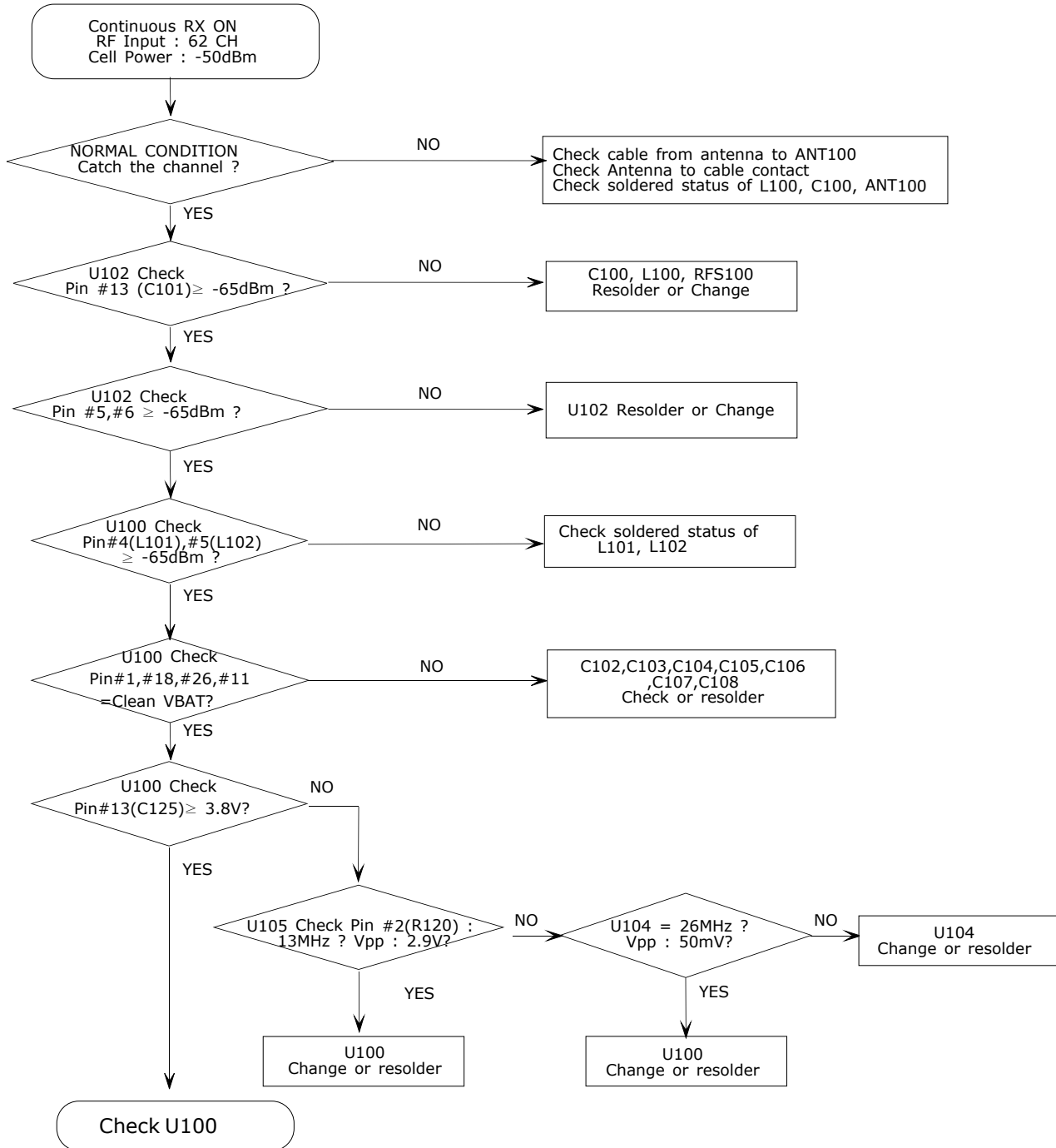

3-2-2. DCS RX

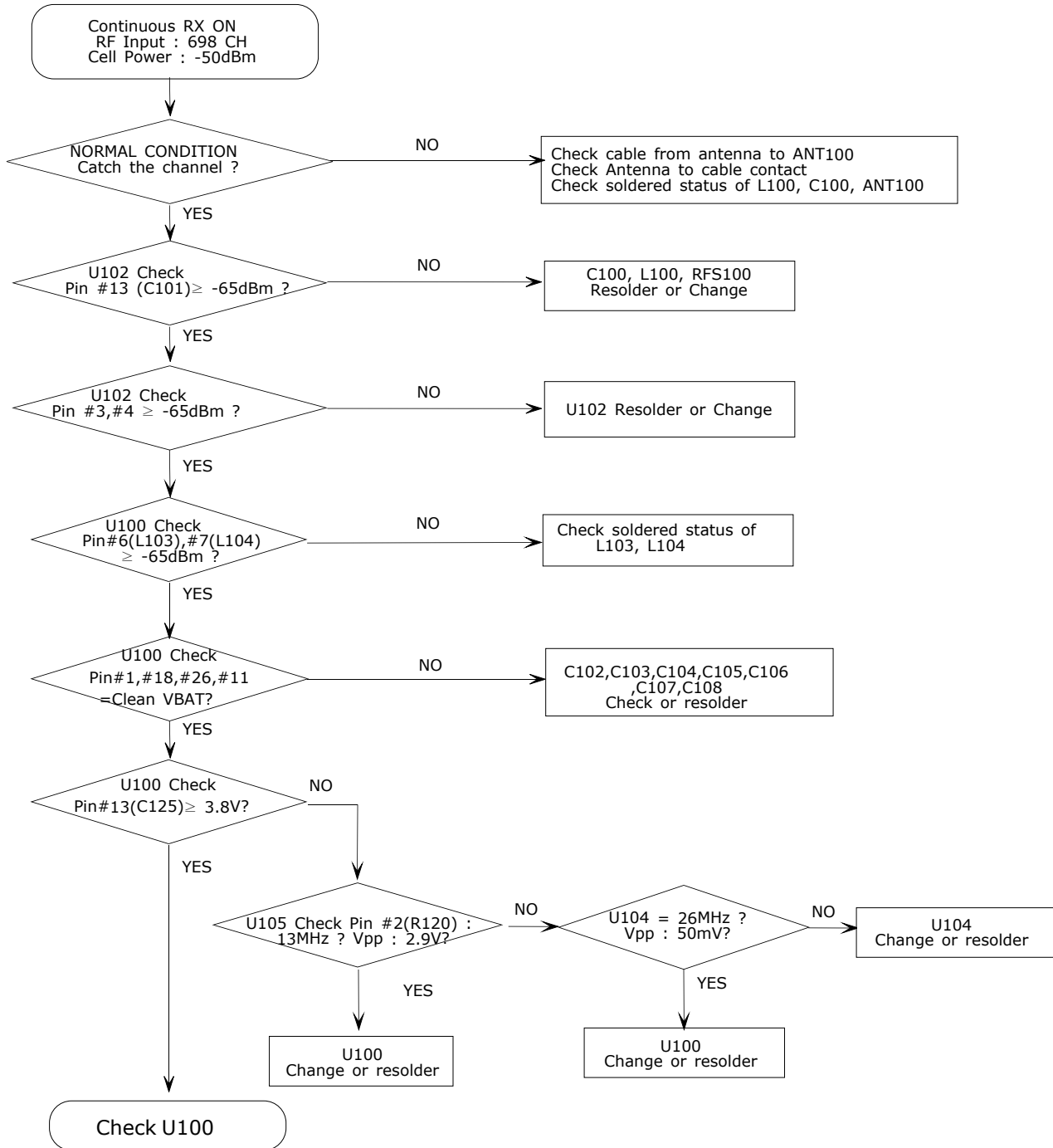

3-2-3. PCS RX

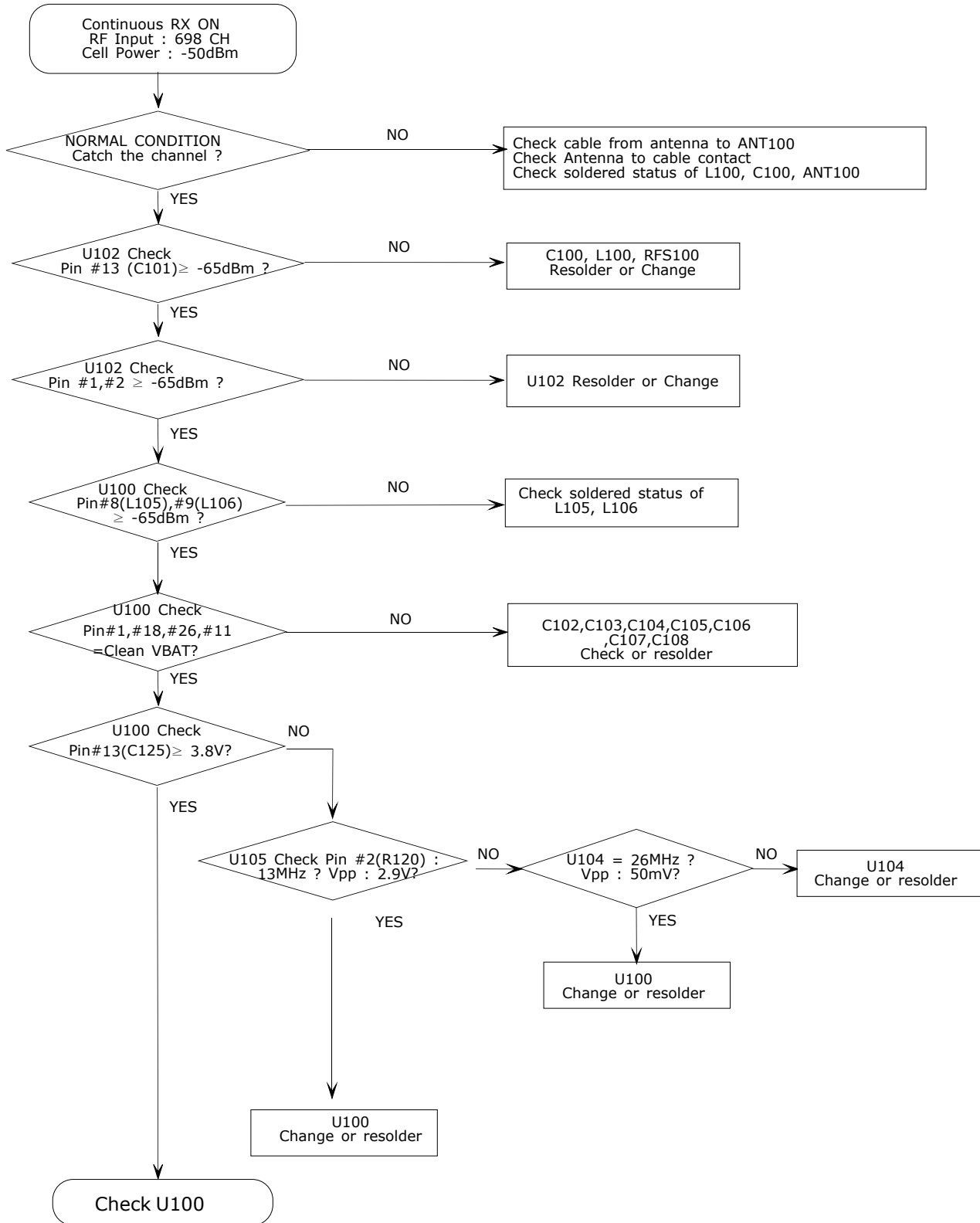

3-2-4. GSM900 TX

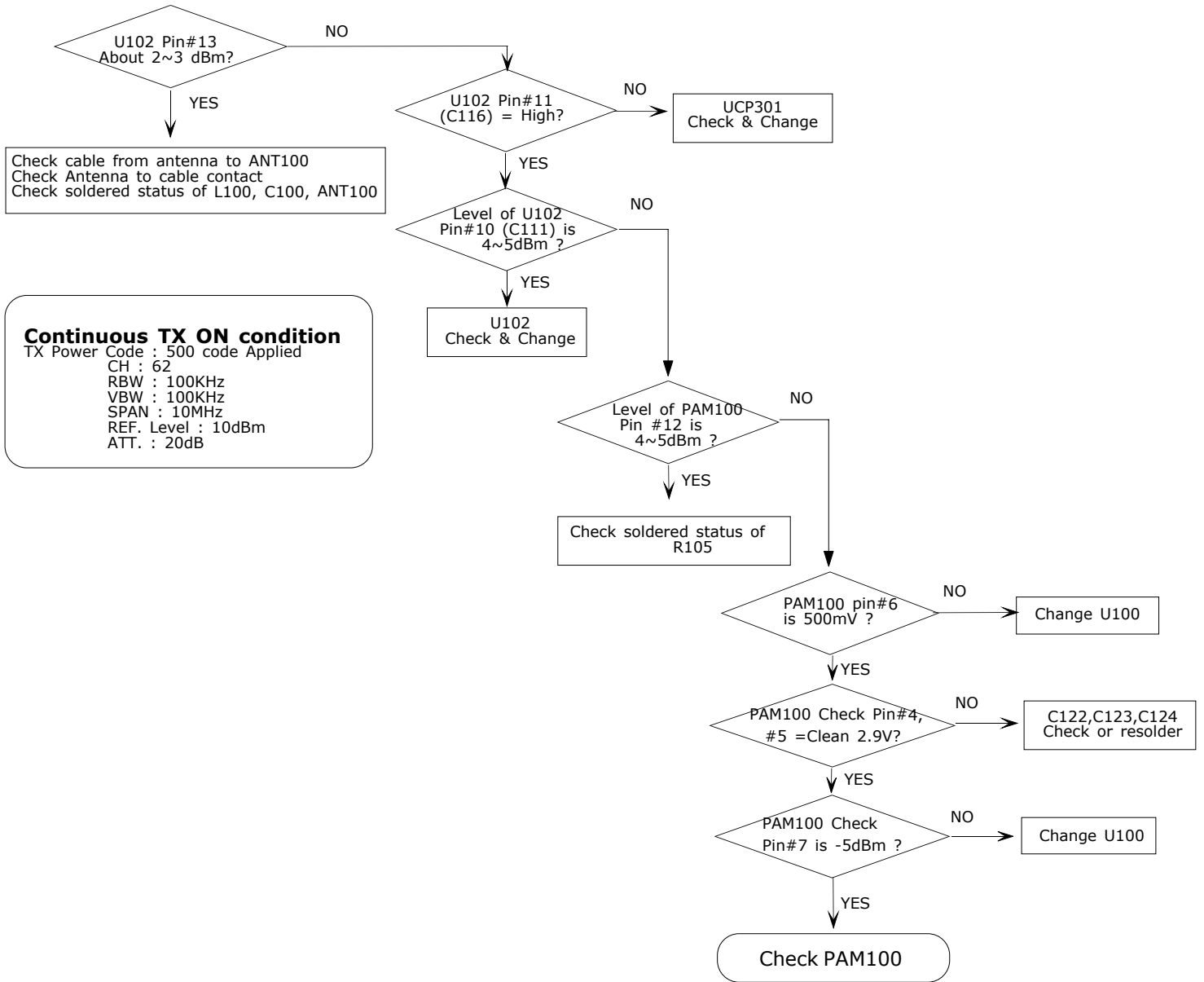

3-2-5. DCS/PCS TX

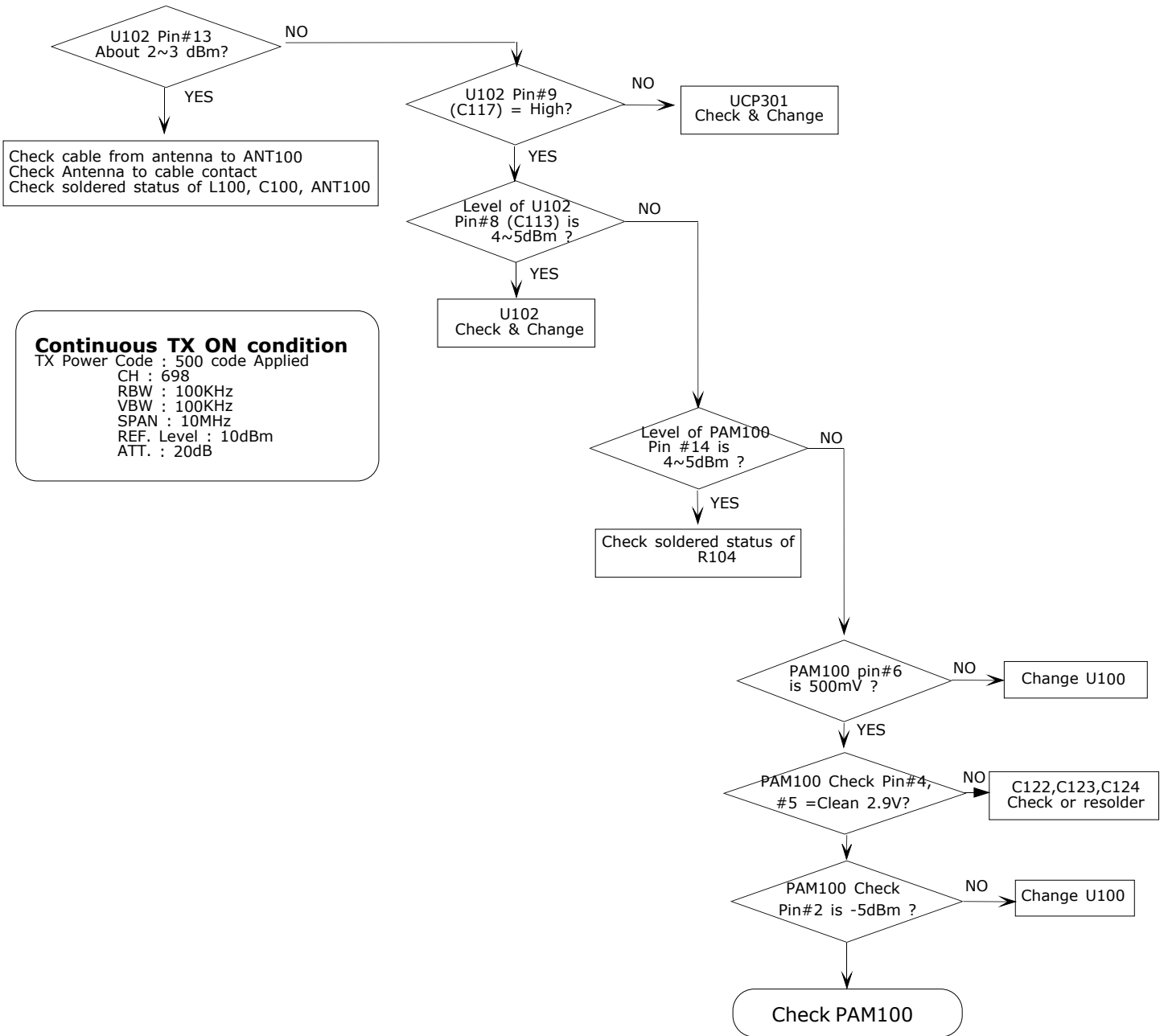

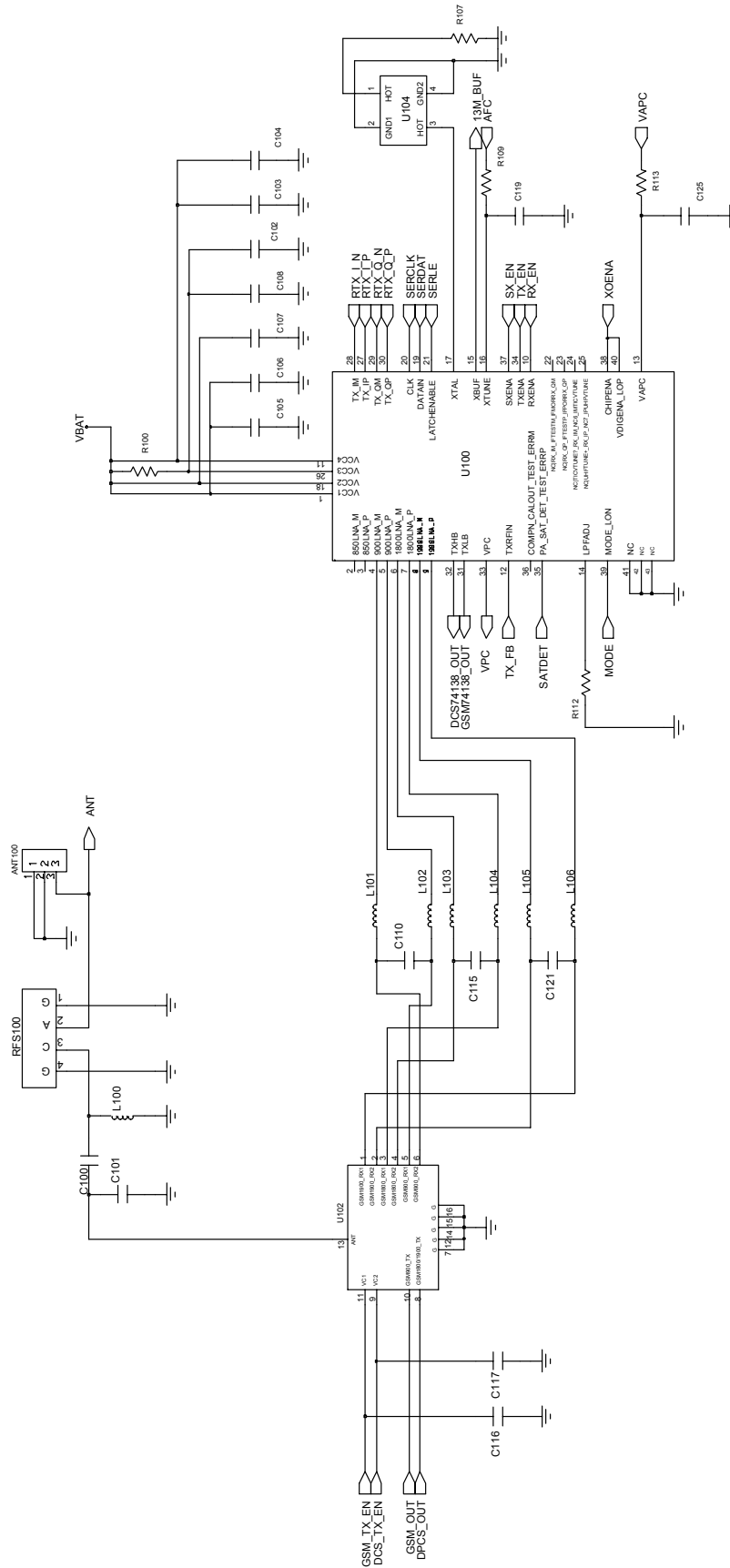

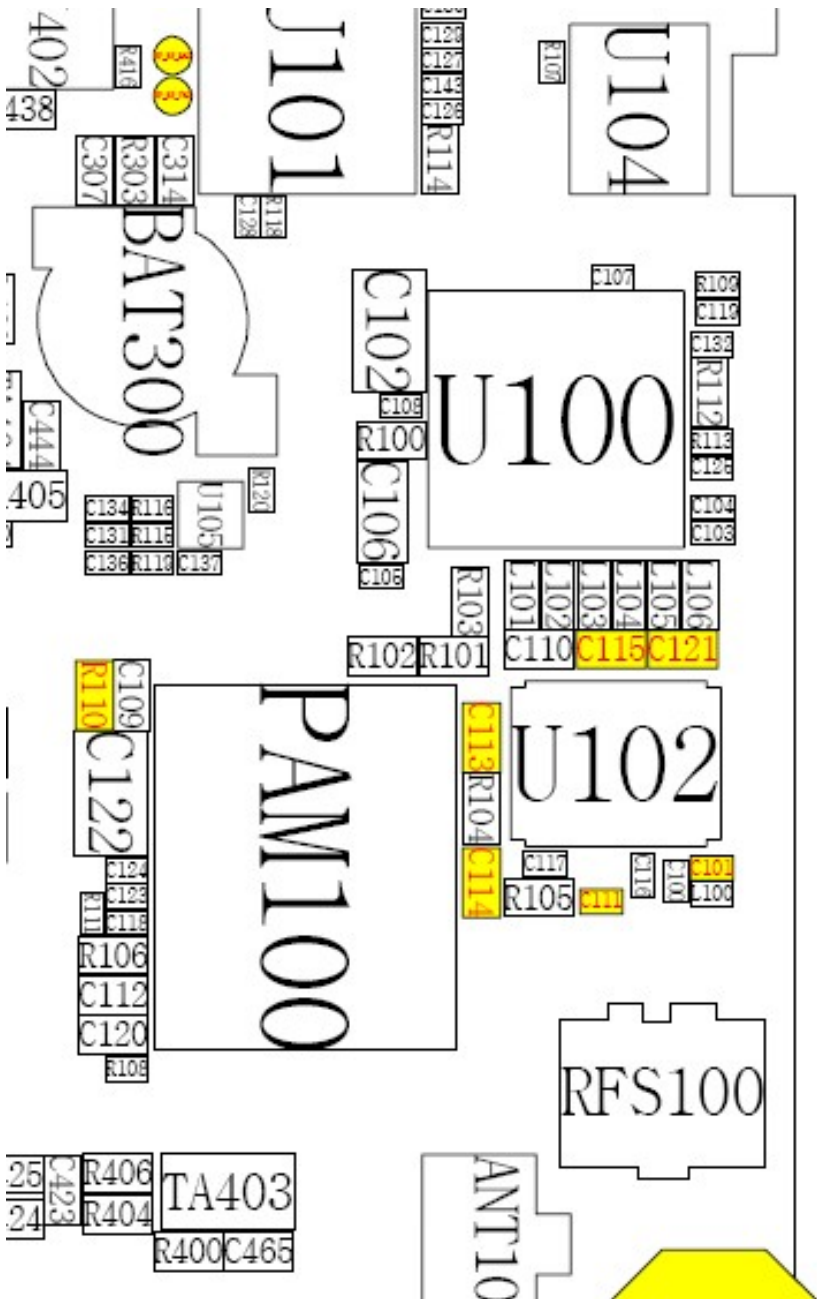

4. Array course control

4-1. Software Adjustments

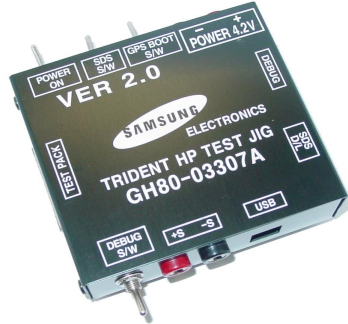

Test Jig (GH80-03307A)



Test Cable (GH39-00483A)



RF Test Cable (GH39-00397A)

4-2. Software Download

4-2-1. Pre-requisite for Download

- Downloader Program(**OptiFlash.exe**)
- SGH-S730i Mobile Phone
- USB Data Link Cable
- Binary files

4-2-2. S/W Download Process

1. Load the binary download program by executing the **“OptiFlash.exe”**

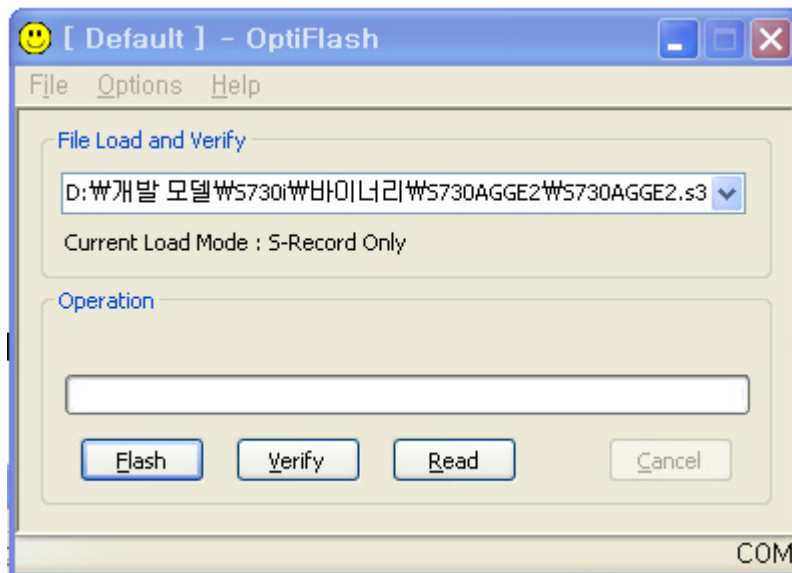

2. Select the **“Options”** -> **“Settings”** -> **“Generic”** -> **“Specify hardware platform”**.

Choose hardware platform for the downloader file setting.

Set the everything else as the default values which are shown below

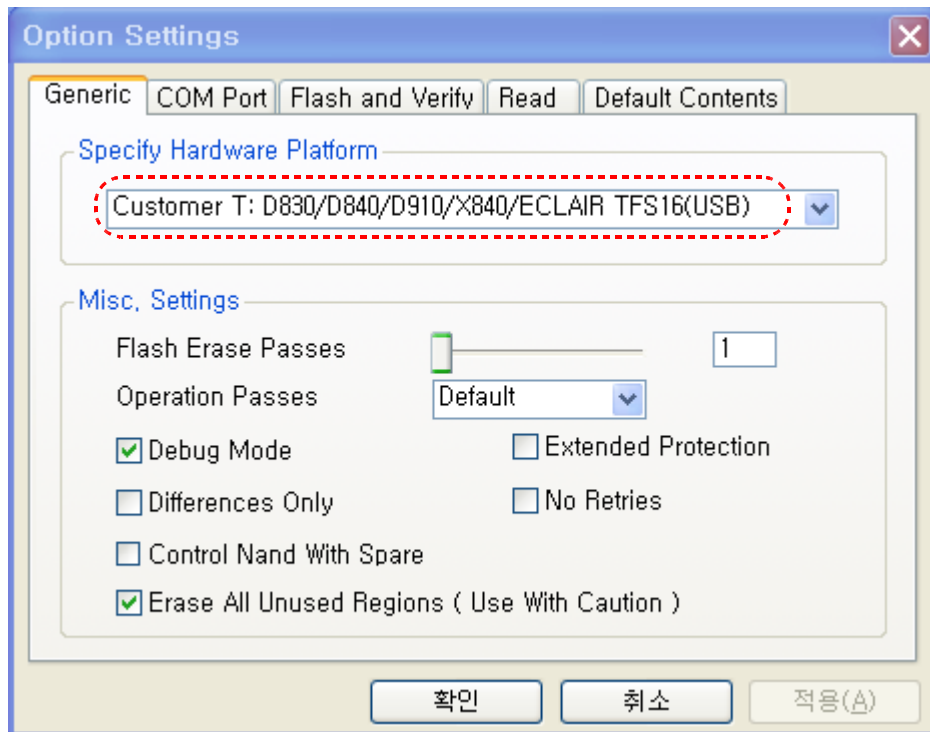

3. Select the **COM port** when the download cable is connected

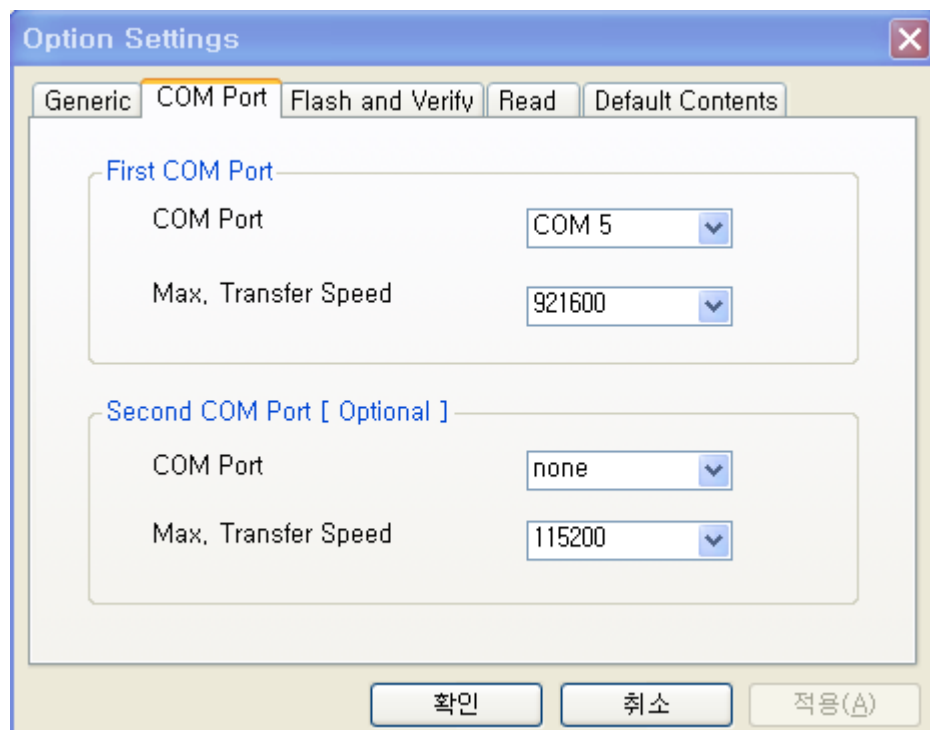

Up to 64 ports are supported. Additionally you can select the maximum transfer speed OptiFlash will use to communicate with the phone.
However, OptiFlash will use a slower speed if either the PC's or the phone's serial hardware is incapable of handling the selected speed.

4. Select the “Flash&Verify” -> “Browse”

Set the directory path and choose the latest s/w binary, for example “S730AGGE2.s3”, for the downloader binary setting.

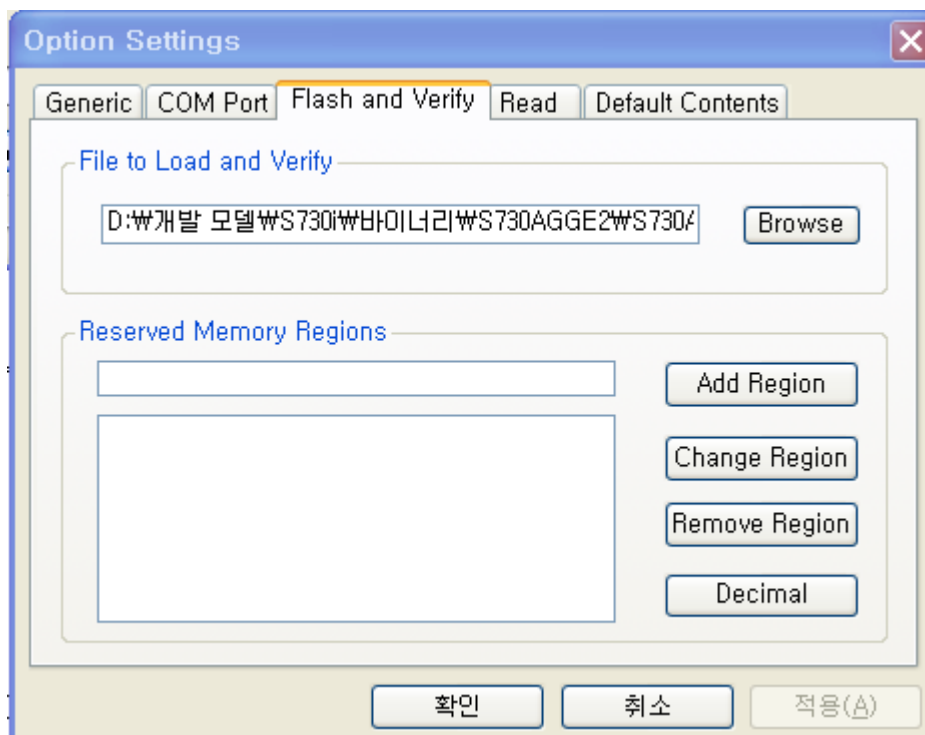

5. Click “OK” button then press “Flash”.

(Before pressing ‘Flash’ button, push the button ‘ * ’ and ‘END’ at the same time. Then press ‘Flash’.)

Downloader will upload the binary file as below for the downloading.

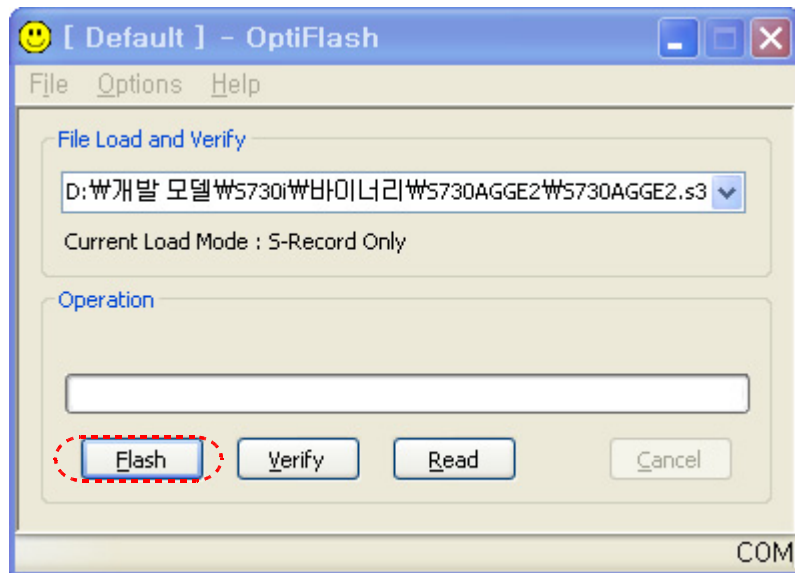

6. When downloading is finished successfully, there is a “All is well” message.
7. After finishing downloading, Certain memory resets should be done to guarantee the normal performance.
8. Confirm the downloaded version name and etc. :
***#1234#**
Full Reset :
***2767*3855#**

5. Block Diagrams

5-1. Base Band Block Diagram

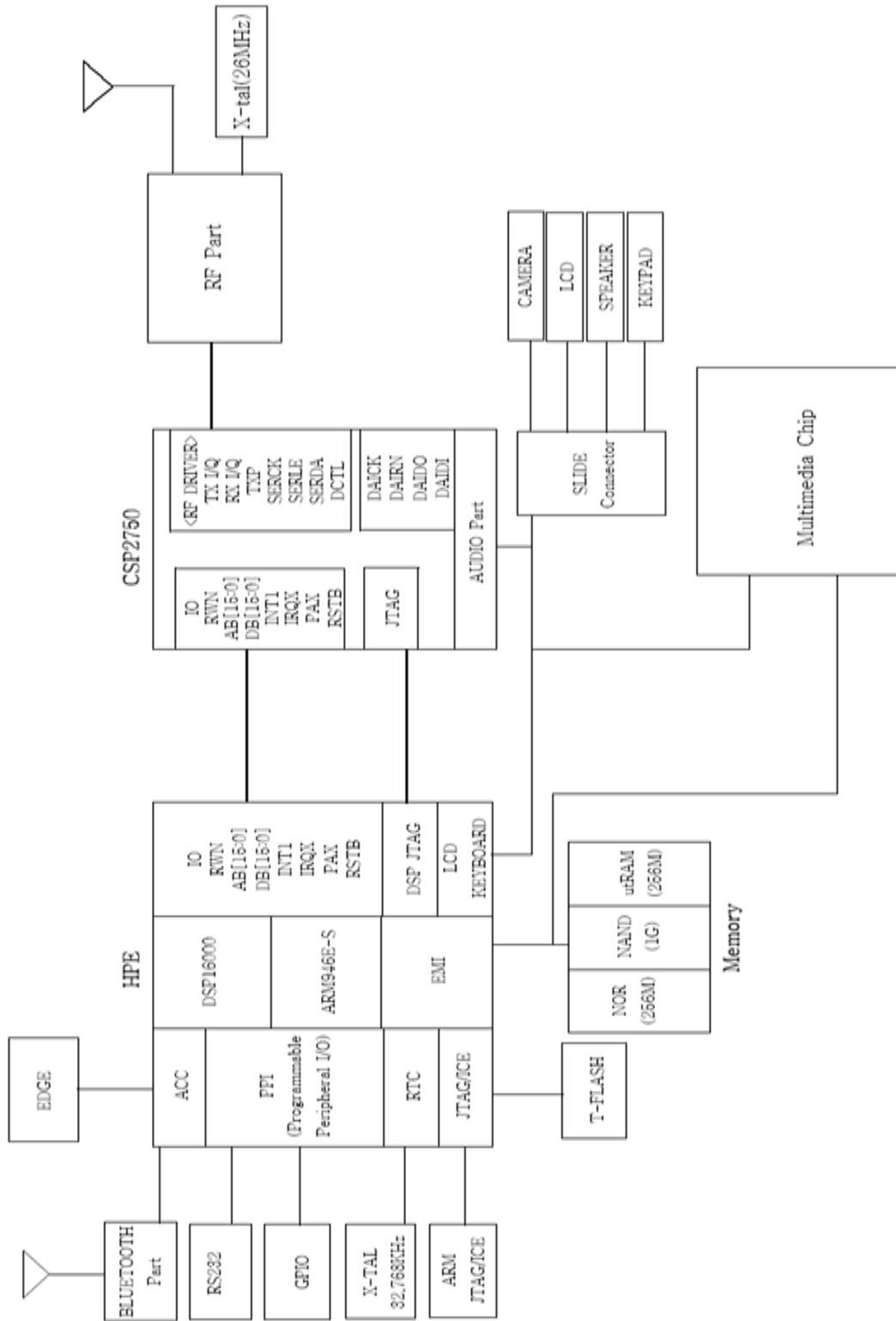

5-2. RF Block Diagram

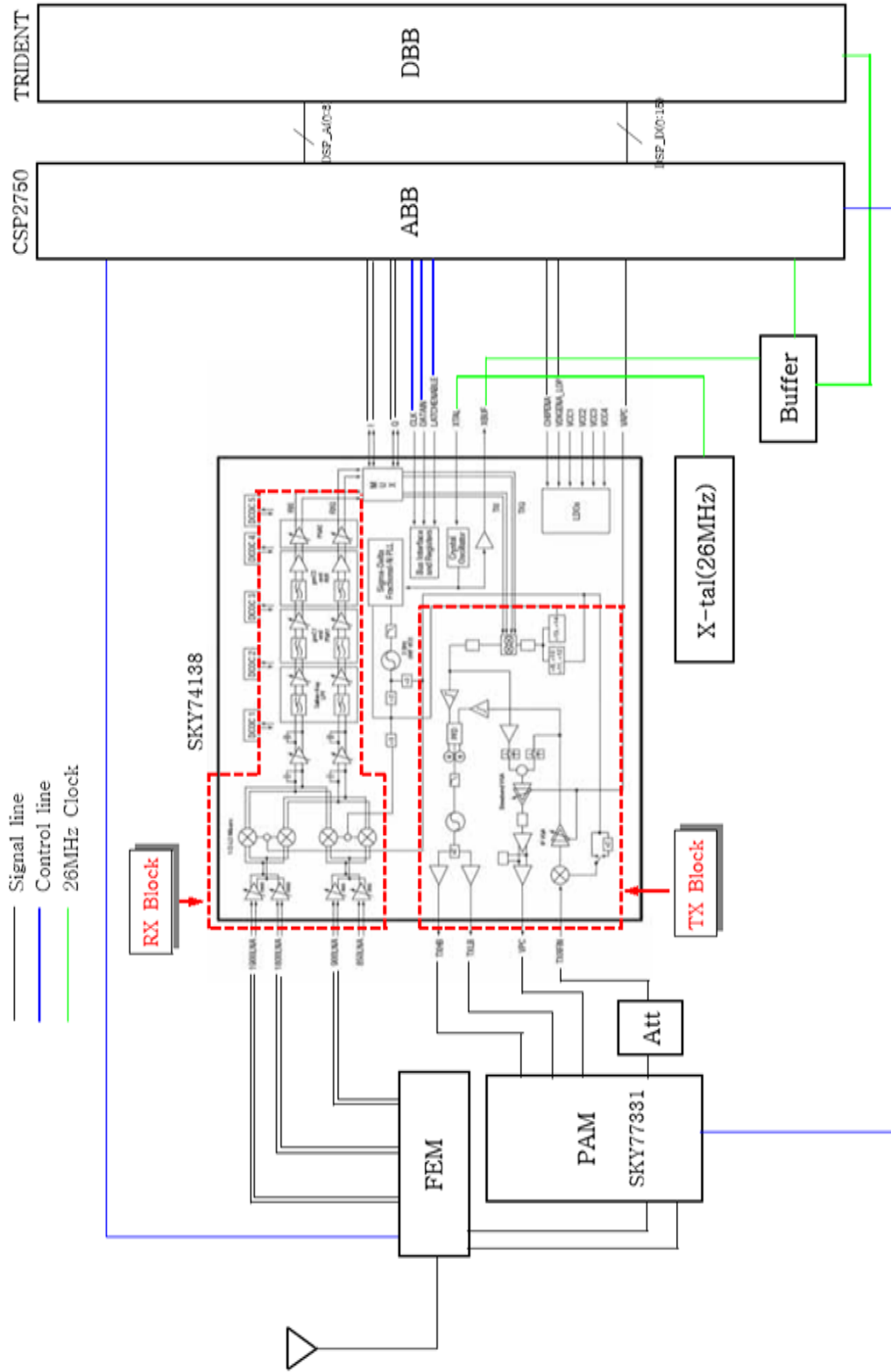

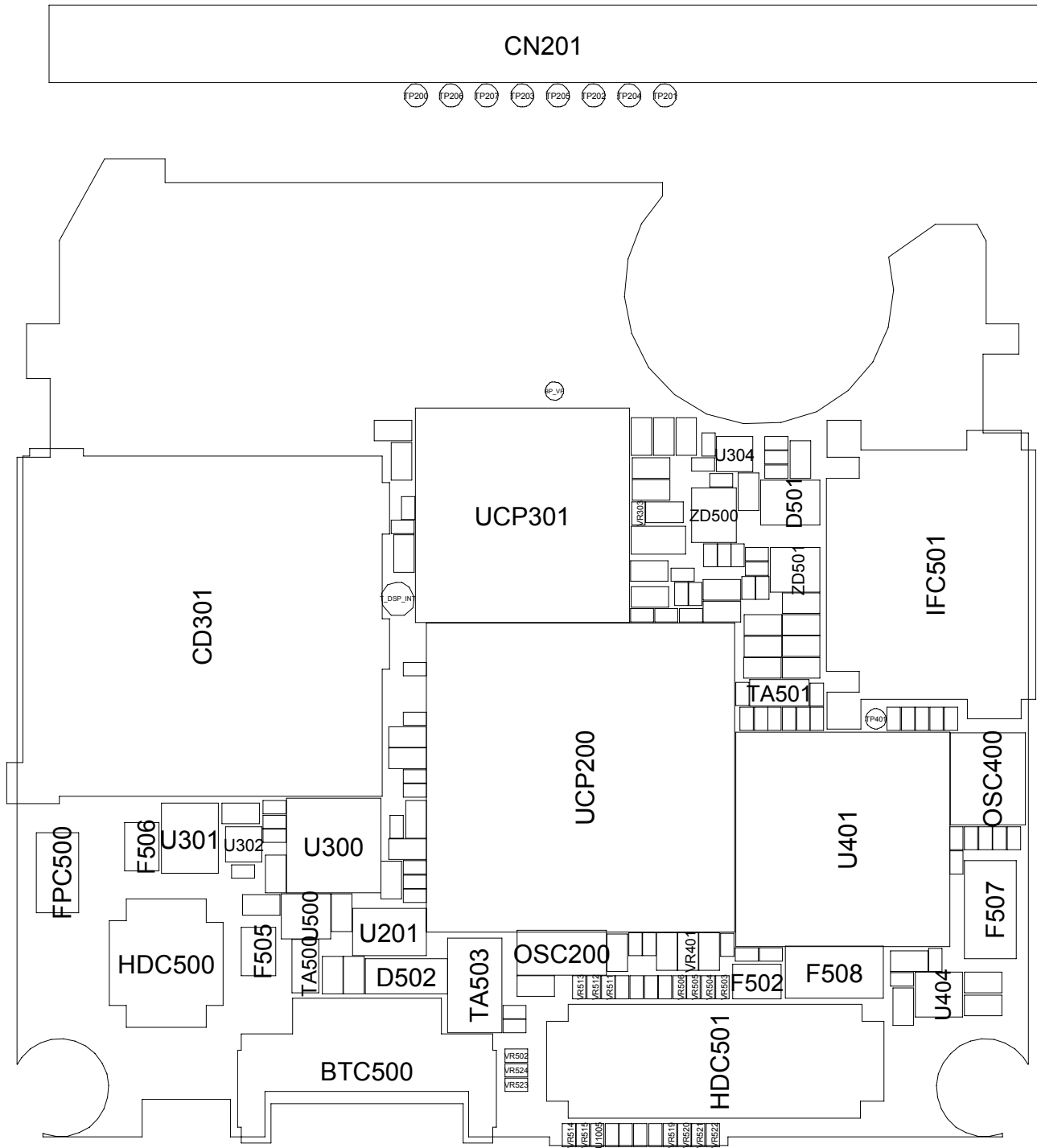

7. MAIN Electrical Parts List

SEC CODE	Design LOC	Discription	STATUS
0403-001411	ZD300	DIODE-ZENER	SA
0403-001547	D502	DIODE-ZENER	SA
0404-001172	D200	DIODE-SCHOTTKY	SA
0406-001167	ZD500	DIODE-TVS	SA
0406-001190	ZD501	DIODE-TVS	SA
0406-001200	U301	DIODE-TVS	SA
0406-001239	D501	DIODE-TVS	SA
0407-001002	D500	DIODE-ARRAY	SA
0505-002207	U408	FET-SILICON	SA
0801-002958	U105	IC-CMOS LOGIC	SA
0801-002958	U302	IC-CMOS LOGIC	SA
0801-002995	U304	IC-CMOS LOGIC	SA
1001-001231	U501	IC-ANALOG SWITCH	SA
1001-001401	U307	IC-ANALOG SWITCH	SA
1001-001410	U405	IC-ANALOG SWITCH	SA
1009-001018	U201	IC-HALL EFFECT S/W	SA
1108-000063	UCP200UP	IC-MCP	SA
1201-002147	U402	IC-VIDEO AMP	SA
1201-002240	U403	IC-AUDIO AMP	SA
1201-002368	PAM100	IC-POWER AMP	SA
1203-003432	U103	IC-POSI.FIXED REG.	SA
1203-003432	U407	IC-POSI.FIXED REG.	SA
1203-003523	U305	IC-POSI.FIXED REG.	SA
1203-003523	U404	IC-POSI.FIXED REG.	SA
1203-003737	U500	IC-POSI.FIXED REG.	SA
1203-003754	U406	IC-POSI.FIXED REG.	SA
1203-003754	U502	IC-POSI.FIXED REG.	SA
1203-003789	U300	IC-POWER SUPERVISOR	SA
1203-004119	UCP301	IC-POWER SUPERVISOR	SA
1203-004164	U200	IC-DC/DC CONVERTER	SA
1203-004518	U303	IC-BATTERY	SA

SEC CODE	Design LOC	Discription	STATUS
1203-004548	U409	IC-DC/DC CONVERTER	SA
1204-002138	UCD400	IC-MELODY	SA
1205-002272	U306	IC-TRANSCEIVER	SA
1205-002946	U400	IC-CODEC	SA
1205-003203	U100	IC-TRANSCEIVER	SA
1205-003210	U401	IC-CODEC	SA
1205-003235	U101	IC-DATA COMM./GEN.	SA
1404-001165	VR306	THERMISTOR-NTC	SA
1405-001082	VR300	VARISTOR	SA
1405-001082	VR500	VARISTOR	SA
1405-001108	VR402	VARISTOR	SA
1405-001121	VR401	VARISTOR	SA
1405-001133	VR200	VARISTOR	SA
1405-001133	VR301	VARISTOR	SA
1405-001133	VR302	VARISTOR	SA
1405-001138	VR501	VARISTOR	SA
1405-001167	VR507	VARISTOR	SA
1405-001183	U1005	VARISTOR	SA
1405-001183	V400	VARISTOR	SA
1405-001183	VR303	VARISTOR	SA
1405-001183	VR502	VARISTOR	SA
1405-001183	VR503	VARISTOR	SA
1405-001183	VR504	VARISTOR	SA
1405-001183	VR505	VARISTOR	SA
1405-001183	VR506	VARISTOR	SA
1405-001183	VR511	VARISTOR	SA
1405-001183	VR512	VARISTOR	SA
1405-001183	VR513	VARISTOR	SA
1405-001183	VR514	VARISTOR	SA
1405-001183	VR515	VARISTOR	SA
1405-001183	VR519	VARISTOR	SA

SEC CODE	Design LOC	Discription	STATUS
1405-001183	VR520	VARISTOR	SA
1405-001183	VR521	VARISTOR	SA
1405-001183	VR522	VARISTOR	SA
1405-001183	VR523	VARISTOR	SA
1405-001183	VR524	VARISTOR	SA
2007-000139	R102	R-CHIP	SA
2007-000139	R103	R-CHIP	SA
2007-000140	R500	R-CHIP	SA
2007-000141	R303	R-CHIP	SA
2007-000143	R307	R-CHIP	SA
2007-000157	R319	R-CHIP	SA
2007-000157	R422	R-CHIP	SA
2007-000157	R514	R-CHIP	SA
2007-000163	R308	R-CHIP	SA
2007-000171	R104	R-CHIP	SA
2007-000171	R105	R-CHIP	SA
2007-000775	R402	R-CHIP	SA
2007-000775	R403	R-CHIP	SA
2007-000831	R501	R-CHIP	SA
2007-000982	R313	R-CHIP	SA
2007-001119	R400	R-CHIP	SA
2007-001119	R504	R-CHIP	SA
2007-001284	R200	R-CHIP	SA
2007-001290	R101	R-CHIP	SA
2007-002965	R432	R-CHIP	SA
2007-002965	R433	R-CHIP	SA
2007-003015	R114	R-CHIP	SA
2007-007009	R417	R-CHIP	SA
2007-007015	R312	R-CHIP	SA
2007-007107	R401	R-CHIP	SA
2007-007134	R112	R-CHIP	SA

SEC CODE	Design LOC	Discription	STATUS
2007-007142	R425	R-CHIP	SA
2007-007142	R503	R-CHIP	SA
2007-007142	R506	R-CHIP	SA
2007-007156	R100	R-CHIP	SA
2007-007308	R420	R-CHIP	SA
2007-007308	R421	R-CHIP	SA
2007-007317	R106	R-CHIP	SA
2007-007317	R404	R-CHIP	SA
2007-007317	R406	R-CHIP	SA
2007-007528	R509	R-CHIP	SA
2007-007528	R510	R-CHIP	SA
2007-007529	R502	R-CHIP	SA
2007-007529	R505	R-CHIP	SA
2007-007590	R323	R-CHIP	SA
2007-007590	R326	R-CHIP	SA
2007-007741	R113	R-CHIP	SA
2007-007741	R321	R-CHIP	SA
2007-007741	R325	R-CHIP	SA
2007-008044	R111	R-CHIP	SA
2007-008045	R116	R-CHIP	SA
2007-008045	R119	R-CHIP	SA
2007-008045	R318	R-CHIP	SA
2007-008045	R516	R-CHIP	SA
2007-008051	R408	R-CHIP	SA
2007-008052	R411	R-CHIP	SA
2007-008055	R202	R-CHIP	SA
2007-008055	R204	R-CHIP	SA
2007-008055	R207	R-CHIP	SA
2007-008055	R208	R-CHIP	SA
2007-008055	R316	R-CHIP	SA
2007-008055	R410	R-CHIP	SA

SEC CODE	Design LOC	Discription	STATUS
2007-008055	R507	R-CHIP	SA
2007-008055	R508	R-CHIP	SA
2007-008057	R416	R-CHIP	SA
2007-008297	R305	R-CHIP	SA
2007-008419	R511	R-CHIP	SA
2007-008419	R512	R-CHIP	SA
2007-008419	R513	R-CHIP	SA
2007-008420	R322	R-CHIP	SA
2007-008420	R324	R-CHIP	SA
2007-008478	R320	R-CHIP	SA
2007-008483	R118	R-CHIP	SA
2007-008483	R121	R-CHIP	SA
2007-008483	R201	R-CHIP	SA
2007-008483	R203	R-CHIP	SA
2007-008483	R300	R-CHIP	SA
2007-008483	R301	R-CHIP	SA
2007-008483	R302	R-CHIP	SA
2007-008483	R311	R-CHIP	SA
2007-008483	R317	R-CHIP	SA
2007-008483	R329	R-CHIP	SA
2007-008483	R415	R-CHIP	SA
2007-008483	R423	R-CHIP	SA
2007-008483	R427	R-CHIP	SA
2007-008483	R428	R-CHIP	SA
2007-008483	R515	R-CHIP	SA
2007-008486	R304	R-CHIP	SA
2007-008516	R109	R-CHIP	SA
2007-008516	R206	R-CHIP	SA
2007-008516	R309	R-CHIP	SA
2007-008531	R435	R-CHIP	SA
2007-008531	R436	R-CHIP	SA

SEC CODE	Design LOC	Discription	STATUS
2007-008542	R107	R-CHIP	SA
2007-008542	R108	R-CHIP	SA
2007-008542	R327	R-CHIP	SA
2007-008542	R431	R-CHIP	SA
2007-008542	R434	R-CHIP	SA
2007-008587	R115	R-CHIP	SA
2007-008588	R412	R-CHIP	SA
2007-008588	R413	R-CHIP	SA
2007-008588	R418	R-CHIP	SA
2007-008588	R419	R-CHIP	SA
2007-008765	R306	R-CHIP	SNA
2007-008785	R405	R-CHIP	SNA
2007-008785	R407	R-CHIP	SNA
2007-009084	R409	R-CHIP	SA
2007-009111	R424	R-CHIP	SA
2007-009111	R426	R-CHIP	SA
2007-009169	R314	R-CHIP	SA
2007-009170	R315	R-CHIP	SA
2007-009233	R310	R-CHIP	SA
2007-009314	R120	R-CHIP	SA
2007-009354	R414	R-CHIP	SA
2203-000233	C120	C-CER,CHIP	SA
2203-000233	C307	C-CER,CHIP	SA
2203-000233	C314	C-CER,CHIP	SA
2203-000254	C209	C-CER,CHIP	SA
2203-000254	C319	C-CER,CHIP	SA
2203-000278	C221	C-CER,CHIP	SA
2203-000278	C222	C-CER,CHIP	SA
2203-000386	C423	C-CER,CHIP	SA
2203-000438	C442	C-CER,CHIP	SA
2203-000438	C443	C-CER,CHIP	SA

SEC CODE	Design LOC	Discription	STATUS
2203-000654	C419	C-CER,CHIP	SA
2203-000812	C112	C-CER,CHIP	SA
2203-000995	C210	C-CER,CHIP	SA
2203-001033	C420	C-CER,CHIP	SA
2203-001405	C320	C-CER,CHIP	SA
2203-002677	C110	C-CER,CHIP	SA
2203-002709	C424	C-CER,CHIP	SA
2203-002709	C425	C-CER,CHIP	SA
2203-005481	C329	C-CER,CHIP	SA
2203-005481	C331	C-CER,CHIP	SA
2203-005481	C415	C-CER,CHIP	SA
2203-005482	C334	C-CER,CHIP	SA
2203-005682	C124	C-CER,CHIP	SA
2203-005682	C134	C-CER,CHIP	SA
2203-005682	C136	C-CER,CHIP	SA
2203-005682	C304	C-CER,CHIP	SA
2203-005682	C330	C-CER,CHIP	SA
2203-005682	C332	C-CER,CHIP	SA
2203-005682	C507	C-CER,CHIP	SA
2203-005682	C508	C-CER,CHIP	SA
2203-005682	C511	C-CER,CHIP	SA
2203-005682	C512	C-CER,CHIP	SA
2203-005682	C518	C-CER,CHIP	SA
2203-005683	C520	C-CER,CHIP	SA
2203-005683	C521	C-CER,CHIP	SA
2203-005683	C522	C-CER,CHIP	SA
2203-005683	C523	C-CER,CHIP	SA
2203-005683	C524	C-CER,CHIP	SA
2203-005683	C525	C-CER,CHIP	SA
2203-005683	R430	C-CER,CHIP	SA
2203-005719	C430	C-CER,CHIP	SA

SEC CODE	Design LOC	Discription	STATUS
2203-005719	C431	C-CER,CHIP	SA
2203-005719	C461	C-CER,CHIP	SA
2203-005719	C462	C-CER,CHIP	SA
2203-005725	C100	C-CER,CHIP	SA
2203-005725	C108	C-CER,CHIP	SA
2203-005729	C130	C-CER,CHIP	SA
2203-005729	C504	C-CER,CHIP	SA
2203-005736	C103	C-CER,CHIP	SA
2203-005736	C117	C-CER,CHIP	SA
2203-005736	C133	C-CER,CHIP	SA
2203-005736	C407	C-CER,CHIP	SA
2203-005736	C409	C-CER,CHIP	SA
2203-005792	C138	C-CER,CHIP	SA
2203-005806	C427	C-CER,CHIP	SNA
2203-006048	C303	C-CER,CHIP	SA
2203-006048	C309	C-CER,CHIP	SA
2203-006048	C311	C-CER,CHIP	SA
2203-006048	C325	C-CER,CHIP	SA
2203-006048	C327	C-CER,CHIP	SA
2203-006048	C328	C-CER,CHIP	SA
2203-006048	C336	C-CER,CHIP	SA
2203-006048	C337	C-CER,CHIP	SA
2203-006121	C118	C-CER,CHIP	SA
2203-006194	C105	C-CER,CHIP	SA
2203-006194	C119	C-CER,CHIP	SA
2203-006194	C123	C-CER,CHIP	SA
2203-006194	C127	C-CER,CHIP	SA
2203-006194	C128	C-CER,CHIP	SA
2203-006194	C129	C-CER,CHIP	SA
2203-006194	C200	C-CER,CHIP	SA
2203-006194	C203	C-CER,CHIP	SA

SEC CODE	Design LOC	Discription	STATUS
2203-006194	C205	C-CER,CHIP	SA
2203-006194	C207	C-CER,CHIP	SA
2203-006194	C208	C-CER,CHIP	SA
2203-006194	C300	C-CER,CHIP	SA
2203-006194	C301	C-CER,CHIP	SA
2203-006194	U1006	C-CER,CHIP	SA
2203-006257	C459	C-CER,CHIP	SA
2203-006257	C465	C-CER,CHIP	SA
2203-006260	C206	C-CER,CHIP	SA
2203-006260	C503	C-CER,CHIP	SA
2203-006260	C506	C-CER,CHIP	SA
2203-006305	C116	C-CER,CHIP	SA
2203-006305	C131	C-CER,CHIP	SA
2203-006305	C132	C-CER,CHIP	SA
2203-006305	C140	C-CER,CHIP	SA
2203-006305	C432	C-CER,CHIP	SA
2203-006305	C433	C-CER,CHIP	SA
2203-006324	C106	C-CER,CHIP	SA
2203-006324	C306	C-CER,CHIP	SA
2203-006324	C448	C-CER,CHIP	SA
2203-006324	C449	C-CER,CHIP	SA
2203-006361	C102	C-CER,CHIP	SA
2203-006361	C122	C-CER,CHIP	SA
2203-006361	C223	C-CER,CHIP	SA
2203-006423	C104	C-CER,CHIP	SA
2203-006423	C107	C-CER,CHIP	SA
2203-006423	C126	C-CER,CHIP	SA
2203-006423	C137	C-CER,CHIP	SA
2203-006423	C201	C-CER,CHIP	SA
2203-006423	C202	C-CER,CHIP	SA
2203-006423	C204	C-CER,CHIP	SA

SEC CODE	Design LOC	Discription	STATUS
2203-006423	C220	C-CER,CHIP	SA
2203-006423	C302	C-CER,CHIP	SA
2203-006423	C338	C-CER,CHIP	SA
2203-006423	C401	C-CER,CHIP	SA
2203-006423	C402	C-CER,CHIP	SA
2203-006423	C404	C-CER,CHIP	SA
2203-006423	C405	C-CER,CHIP	SA
2203-006423	C406	C-CER,CHIP	SA
2203-006423	C408	C-CER,CHIP	SA
2203-006423	C411	C-CER,CHIP	SA
2203-006423	C412	C-CER,CHIP	SA
2203-006423	C413	C-CER,CHIP	SA
2203-006423	C416	C-CER,CHIP	SA
2203-006423	C426	C-CER,CHIP	SA
2203-006423	C434	C-CER,CHIP	SA
2203-006423	C435	C-CER,CHIP	SA
2203-006423	C439	C-CER,CHIP	SA
2203-006423	C460	C-CER,CHIP	SA
2203-006423	C463	C-CER,CHIP	SA
2203-006423	C464	C-CER,CHIP	SA
2203-006556	C218	C-CER,CHIP	SA
2203-006562	C141	C-CER,CHIP	SA
2203-006562	C142	C-CER,CHIP	SA
2203-006562	C217	C-CER,CHIP	SA
2203-006562	C305	C-CER,CHIP	SA
2203-006562	C308	C-CER,CHIP	SA
2203-006562	C310	C-CER,CHIP	SA
2203-006562	C312	C-CER,CHIP	SA
2203-006562	C313	C-CER,CHIP	SA
2203-006562	C315	C-CER,CHIP	SA
2203-006562	C316	C-CER,CHIP	SA

SEC CODE	Design LOC	Discription	STATUS
2203-006562	C317	C-CER,CHIP	SA
2203-006562	C318	C-CER,CHIP	SA
2203-006562	C324	C-CER,CHIP	SA
2203-006562	C326	C-CER,CHIP	SA
2203-006562	C403	C-CER,CHIP	SA
2203-006562	C428	C-CER,CHIP	SA
2203-006562	C429	C-CER,CHIP	SA
2203-006562	C438	C-CER,CHIP	SA
2203-006562	C444	C-CER,CHIP	SA
2203-006562	C445	C-CER,CHIP	SA
2203-006562	C447	C-CER,CHIP	SA
2203-006562	C450	C-CER,CHIP	SA
2203-006562	C456	C-CER,CHIP	SA
2203-006562	C457	C-CER,CHIP	SA
2203-006562	C458	C-CER,CHIP	SA
2203-006562	C500	C-CER,CHIP	SA
2203-006562	C502	C-CER,CHIP	SA
2203-006562	C510	C-CER,CHIP	SA
2203-006562	C516	C-CER,CHIP	SA
2203-006585	C440	C-CER,CHIP	SA
2203-006585	C441	C-CER,CHIP	SA
2203-006626	C333	C-CER,CHIP	SA
2203-006626	C452	C-CER,CHIP	SA
2203-006626	C466	C-CER,CHIP	SA
2203-006626	C467	C-CER,CHIP	SA
2203-006626	C509	C-CER,CHIP	SA
2203-006642	C211	C-CER,CHIP	SA
2203-006642	C212	C-CER,CHIP	SA
2203-006648	C321	C-CER,CHIP	SA
2203-006648	C513	C-CER,CHIP	SA
2203-006674	C139	C-CER,CHIP	SNA

SEC CODE	Design LOC	Discription	STATUS
2203-006708	C453	C-CER,CHIP	SA
2203-006825	C214	C-CER,CHIP	SA
2203-006825	C215	C-CER,CHIP	SA
2203-006825	C216	C-CER,CHIP	SA
2203-006825	C514	C-CER,CHIP	SA
2203-006838	C446	C-CER,CHIP	SA
2203-006838	C455	C-CER,CHIP	SA
2203-006839	C517	C-CER,CHIP	SA
2203-006872	C400	C-CER,CHIP	SA
2203-006872	C410	C-CER,CHIP	SA
2203-006872	C451	C-CER,CHIP	SA
2203-006872	C454	C-CER,CHIP	SA
2203-006896	C125	C-CER,CHIP	SA
2203-006978	C322	C-CER,CHIP	SA
2203-006978	C323	C-CER,CHIP	SA
2404-001339	TA400	C-TA,CHIP	SA
2404-001339	TA404	C-TA,CHIP	SA
2404-001339	TA405	C-TA,CHIP	SA
2404-001339	TA500	C-TA,CHIP	SA
2404-001352	TA403	C-TA,CHIP	SA
2404-001377	TA501	C-TA,CHIP	SA
2404-001381	TA502	C-TA,CHIP	SA
2404-001406	TA503	C-TA,CHIP	SA
2404-001478	TA401	C-TA,CHIP	SA
2404-001478	TA402	C-TA,CHIP	SA
2703-001734	L407	INDUCTOR-SMD	SA
2703-002198	L101	INDUCTOR-SMD	SA
2703-002198	L102	INDUCTOR-SMD	SA
2703-002204	L107	INDUCTOR-SMD	SA
2703-002267	L105	INDUCTOR-SMD	SA
2703-002267	L106	INDUCTOR-SMD	SA

SEC CODE	Design LOC	Discription	STATUS
2703-002281	L103	INDUCTOR-SMD	SA
2703-002281	L104	INDUCTOR-SMD	SA
2703-002700	C109	INDUCTOR-SMD	SA
2703-002734	L200	INDUCTOR-SMD	SA
2703-002749	L201	INDUCTOR-SMD	SA
2703-002910	L100	INDUCTOR-SMD	SA
2703-003001	L406	INDUCTOR-SMD	SA
2801-004458	OSC400	CRYSTAL-SMD	SA
2801-004466	OSC200	CRYSTAL-SMD	SA
2801-004506	OSC100	CRYSTAL-SMD	SA
2801-004552	U104	CRYSTAL-SMD	SA
2901-001348	F507	FILTER-EMI/ESD	SA
2901-001348	F508	FILTER-EMI/ESD	SA
2901-001409	F502	FILTER-EMI SMD	SA
2901-001451	F505	FILTER-EMI SMD	SA
2901-001451	F506	FILTER-EMI SMD	SA
2909-001283	F100	FILTER-LC	SA
2911-000056	U102	DUPLEXER-FEM	SA
3301-001342	L202	BEAD-SMD	SA
3301-001342	L403	BEAD-SMD	SA
3301-001342	L404	BEAD-SMD	SA
3301-001342	L405	BEAD-SMD	SA
3301-001534	L400	BEAD-SMD	SA
3301-001534	L401	BEAD-SMD	SA
3301-001534	L402	BEAD-SMD	SA
3705-001225	ANT100	CONNECTOR-COAXIAL	SA
3705-001358	RFS100	CONNECTOR-COAXIAL	SA
3709-001344	CD301	CONNECTOR-CARD EDGE	SA
3709-001447	SIM300	CONNECTOR-CARD EDGE	SA
3710-002465	IFC501	SOCKET-INTERFACE	SA
3711-005933	HDC501	HEADER-BOARD TO BOARD	SA

SEC CODE	Design LOC	Discription	STATUS
3711-005976	HDC500	HEADER-BOARD TO BOARD	SA
3711-006299	BTC500	HEADER-BATTERY	SA
4202-001314	U106	ANTENNA-CHIP	SA
4302-001158	BAT300	BATTERY-LI(2ND)	SA
GH09-00045A	UCP200	IC MICOM	SA

8. Reference data

8-1. Reference Abbreviate

AAC: Advanced Audio Coding.

AVC : Advanced Video Coding.

BER : Bit Error Rate

BPSK: Binary Phase Shift Keying

CA : Conditional Access

CDM : Code Division Multiplexing

C/I : Carrier to Interference

DMB : Digital Multimedia Broadcasting

EN : European Standard

ES : Elementary Stream

ETSI: European Telecommunications Standards Institute

MPEG: Moving Picture Experts Group

PN : Pseudo-random Noise

PS : Pilot Symbol

QPSK: Quadrature Phase Shift Keying

RS : Reed-Solomon

SI : Service Information

TDM : Time Division Multiplexing

TS : Transport Stream

9. Safety Precautions

9-1. Repair Precaution

- Repair in Shield Box, during detailed tuning.
Take specially care of tuning or test,
because specipcty of cellular phone is sensitive for surrounding interference(RF noise).
- Be careful to use a kind of magnetic object or tool,
because performance of parts is damaged by the influence of manetic force.
- Surely use a standard screwdriver when you disassemble this product,
otherwise screw will be worn away.
- Use a thicken twisted wire when you measure level.
A thicken twisted wire has low resistance, therefore error of measurement is few.
- Repair after separate Test Pack and Set because for short danger (for example an
overcurrent and furious flames of parts etc) when you repair board in condition of
connecting Test Pack and tuning on.
- Take specially care of soldering, because Land of PCB is small and weak in heat.
- Surely tune on/off while using AC power plug, because a repair of battery charger is
dangerous when tuning ON/OFF PBA and Connector after disassembling charger.
- Don't use as you pleases after change other material than replacement registered on SEC
System. Otherwise engineer in charge isn't charged with problem that you don't keep this
rules.

9-2. ESD(Electrostatically Sensitive Devices) Precaution

Several semiconductor may be damaged easily by static electricity. Such parts are called by ESD(Electrostatically Sensitive Devices), for example IC,BGA chip etc. Read Precaution below. You can prevent from ESD damage by static electricity.

- Remove static electricity remained your body before you touch semiconductor or parts with semiconductor. There are ways that you touch an earthed place or wear static electricity prevention string on wrist.
- Use earthed soldering steel when you connect or disconnect ESD.
- Use soldering removing tool to break static electricity. , otherwise ESD will be damaged by static electricity.
- Don't unpack until you set up ESD on product. Because most of ESD are packed by box and aluminum plate to have conductive power,they are prevented from static electricity.
- You must maintain electric contact between ESD and place due to be set up until ESD is connected completely to the proper place or a circuit board.

10. Product Function

Main Function

- Camera and camcorder
- Music player
- Synchronisation with Window Media Player
- Image editor
- Photo printing
- Phone to TV
- Bluetooth
- Offline mode
- File viewer
- SOS message