

SAMSUNG

GSM TELEPHONE

SGH-S410i

SERVICE *Manual*

GSM TELEPHONE

CONTENTS



1. Specification
2. Flow Chart of Troubleshooting
3. Exploded Views and Parts List
4. Electrical Parts List
5. PCB Diagrams
6. Block Diagrams

1. SGH-S410i Specification

1-1. GSM General Specification

	GSM900 Phase 1	EGSM 900 Phase 2	DCS1800 Phase 1	PCS1900
Freq. Band[MHz] Uplink/Downlink	890~915 935~960	880~915 925~960	1710~1785 1805~1880	1850~1910 1930~1990
ARFCN range	1~124	0~124 & 975~1023	512~885	512~810
Tx/Rx spacing	45MHz	45MHz	95MHz	80MHz
Mod. Bit rate/ Bit Period	270.833kbps 3.692us	270.833kbps 3.692us	270.833kbps 3.692us	270.833kbps 3.692us
Time Slot Period/Frame Period	576.9us 4.615ms	576.9us 4.615ms	576.9us 4.615ms	576.9us 4.615ms
Modulation	0.3GMSK	0.3GMSK	0.3GMSK	0.3GMSK
MS Power	33dBm~13dBm	33dBm~5dBm	30dBm~0dBm	30dBm~0dBm
Power Class	5pcl ~ 15pcl	5pcl ~ 19pcl	0pcl ~ 15pcl	0pcl ~ 15pcl
Sensitivity	-102dBm	-102dBm	-100dBm	-100dBm
TDMA Mux	8	8	8	8
Cell Radius	35Km	35Km	2Km	-

1-2. GSM TX power class

TX Power control level	GSM900	TX Power control level	DCS1800	TX Power control level	PCS1900
5	33±2 dBm	0	30±3 dBm	0	30±3 dBm
6	31±2 dBm	1	28±3 dBm	1	28±3 dBm
7	29±2 dBm	2	26±3 dBm	2	26±3 dBm
8	27±2 dBm	3	24±3 dBm	3	24±3 dBm
9	25±2 dBm	4	22±3 dBm	4	22±3 dBm
10	23±2 dBm	5	20±3 dBm	5	20±3 dBm
11	21±2 dBm	6	18±3 dBm	6	18±3 dBm
12	19±2 dBm	7	16±3 dBm	7	16±3 dBm
13	17±2 dBm	8	14±3 dBm	8	14±3 dBm
14	15±2 dBm	9	12±4 dBm	9	12±4 dBm
15	13±2 dBm	10	10±4 dBm	10	10±4 dBm
16	11±3 dBm	11	8±4 dBm	11	8±4 dBm
17	9± 3dBm	12	6±4 dBm	12	6±4 dBm
18	7±3 dBm	13	4±4 dBm	13	4±4 dBm
19	5±3 dBm	14	2±5 dBm	14	2±5 dBm
		15	0±5 dBm	15	0±5 dBm

2. SGH-S410i Flow Chart of Troubleshooting

2-1.Baseband

2-1-1. Power ON

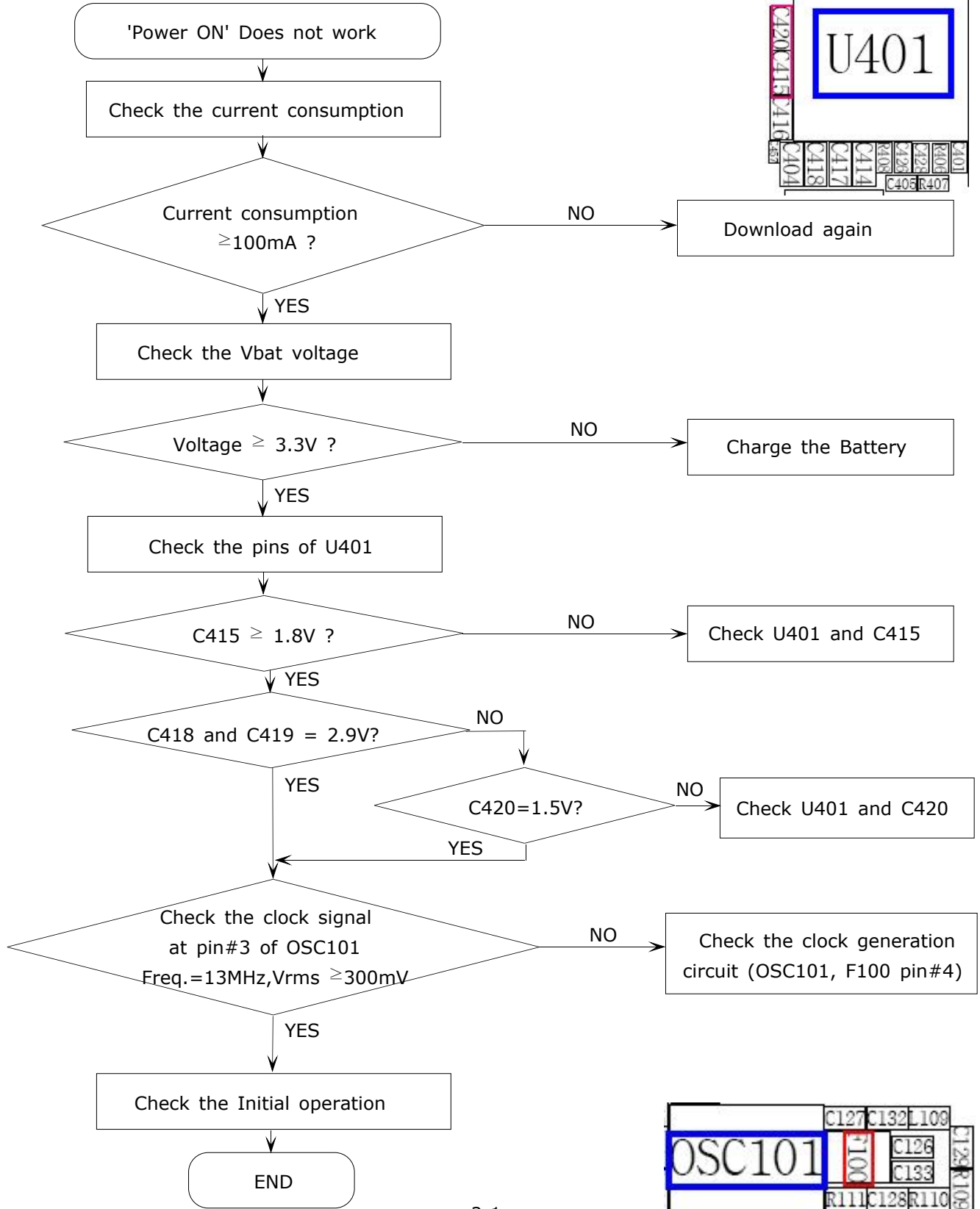

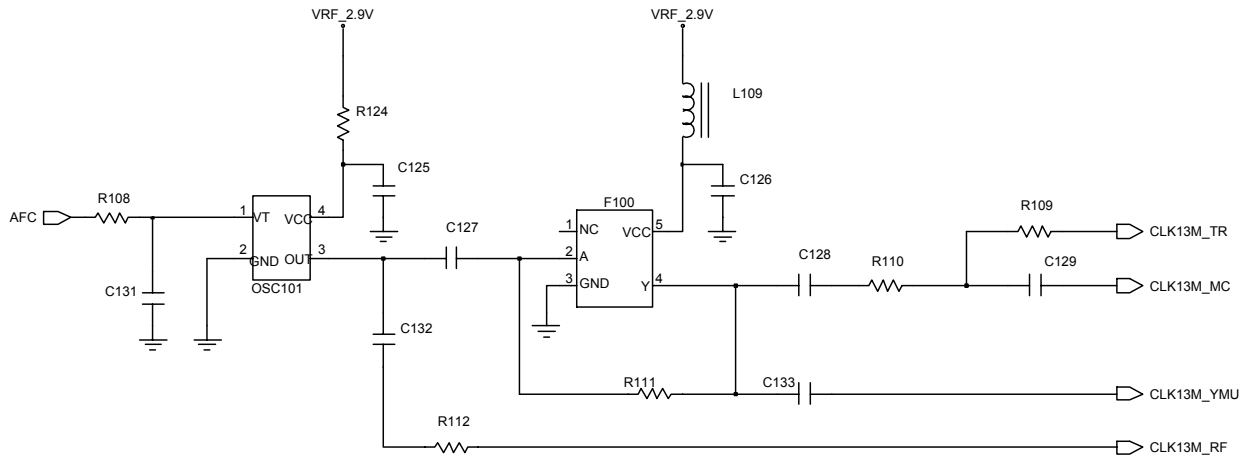
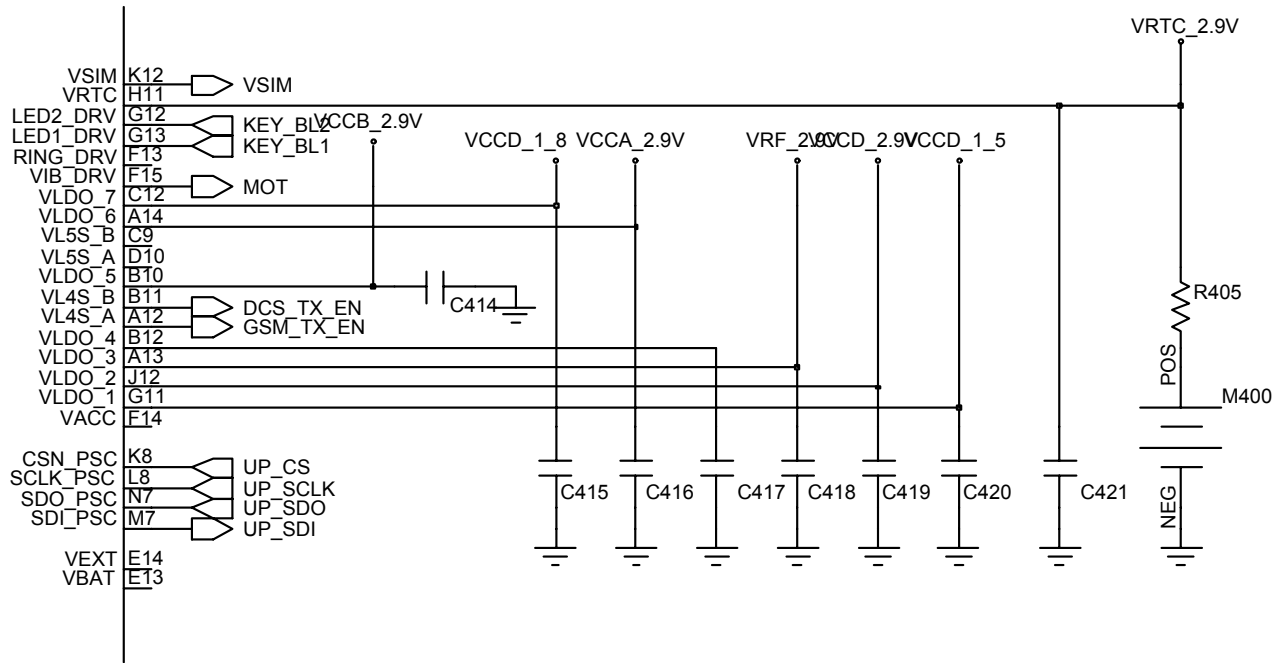

2-1-2. Initial

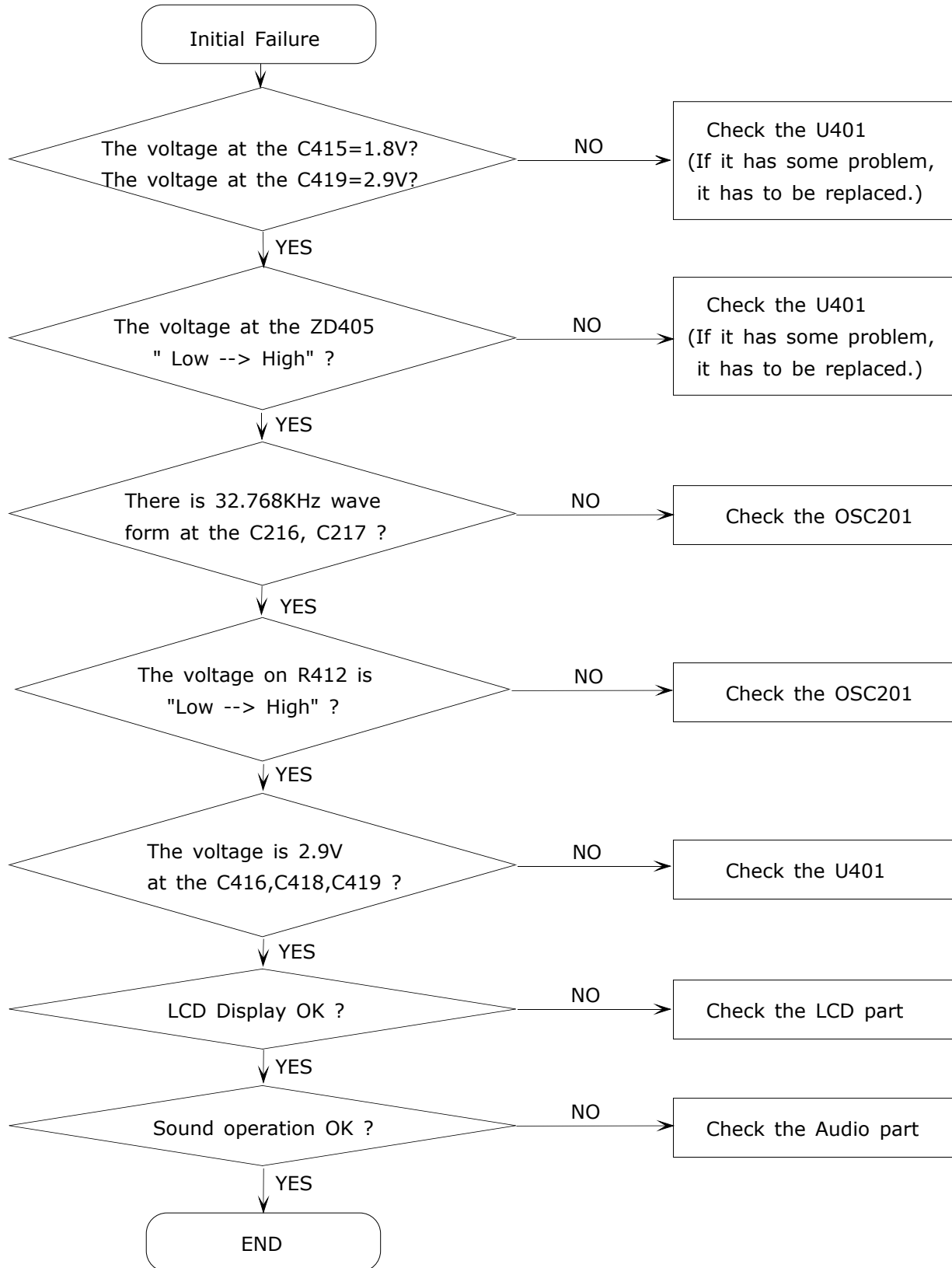

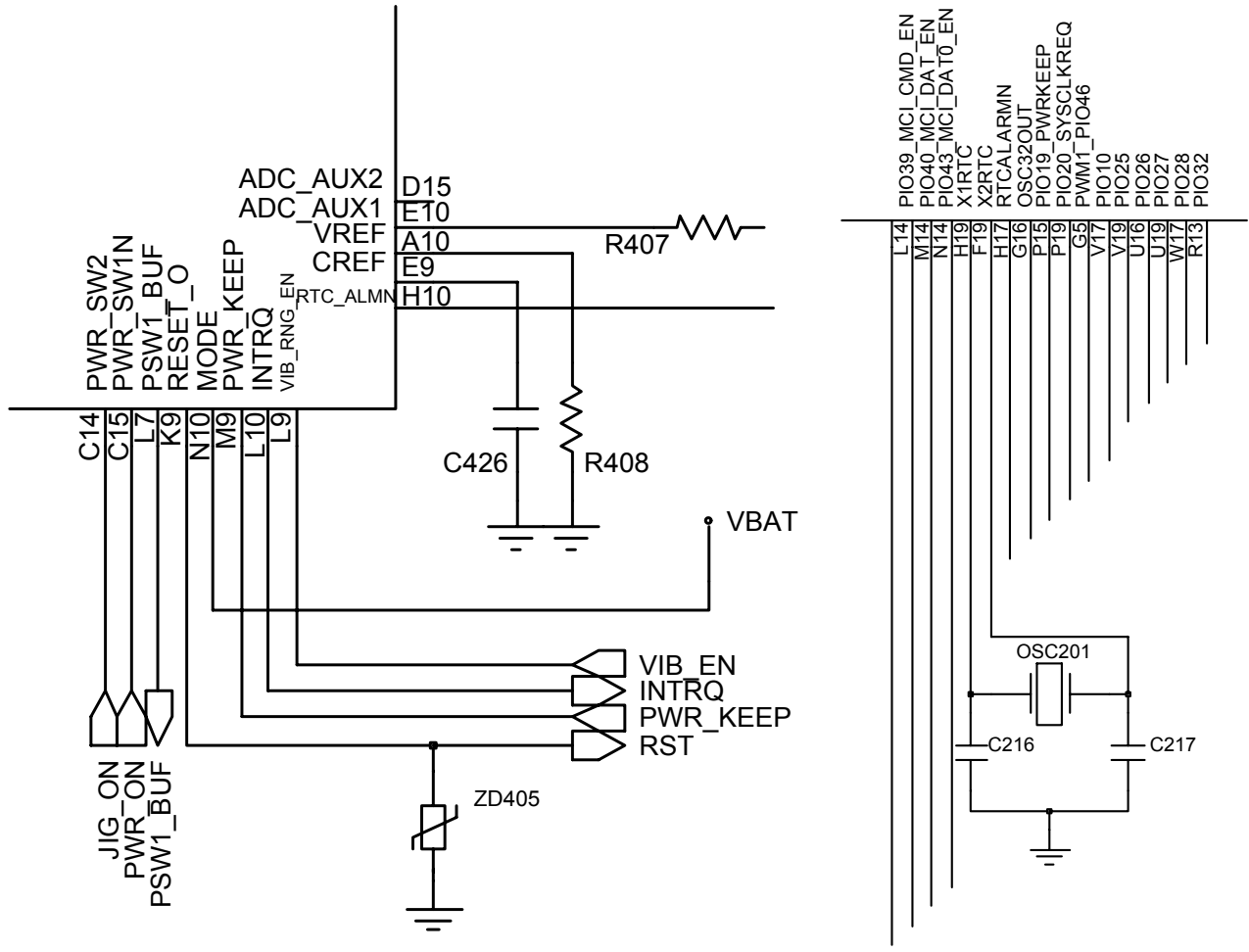
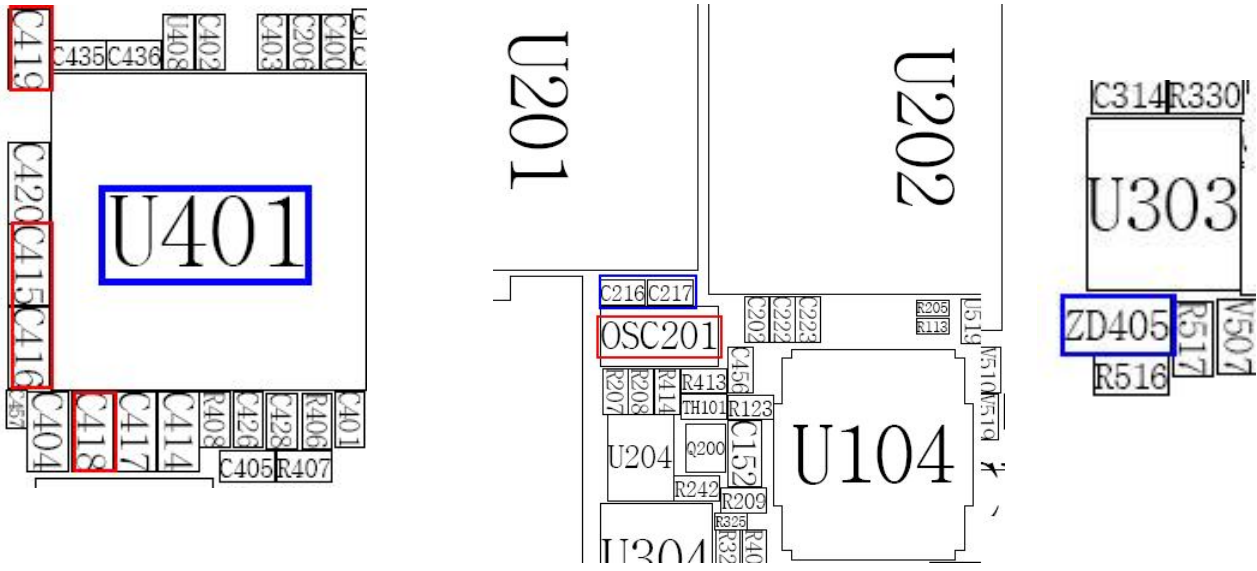

2-1-3. Sim Part

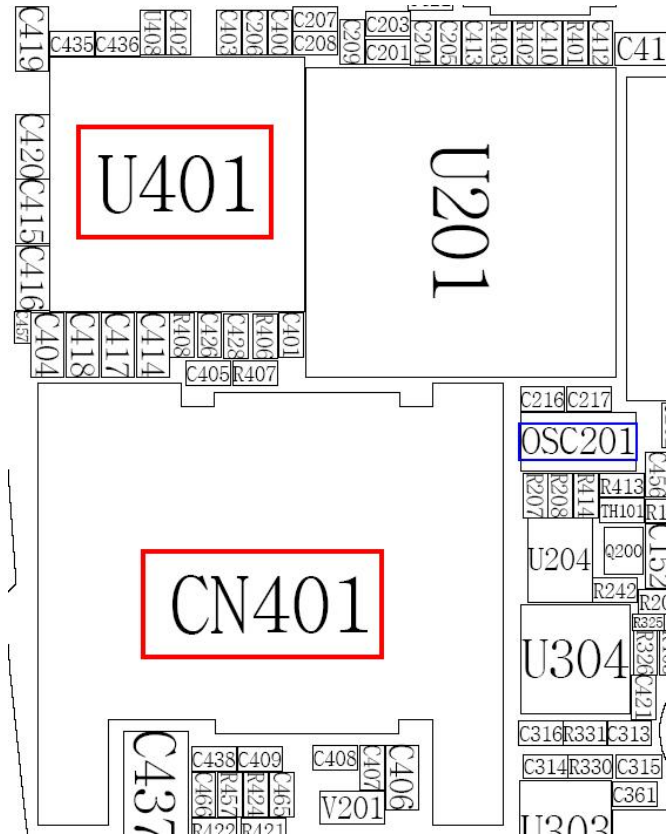
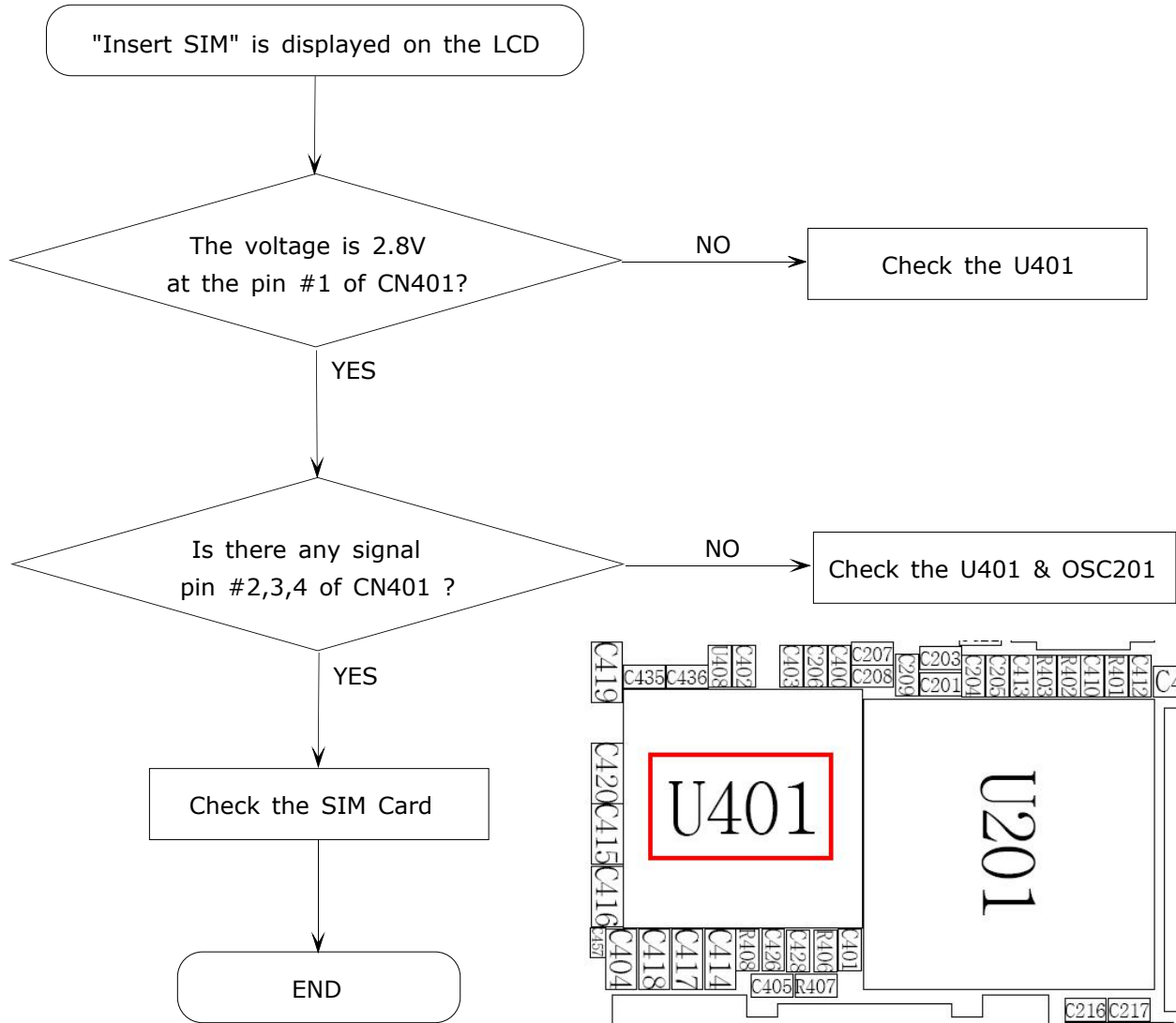

2-1-4. Microphone Part

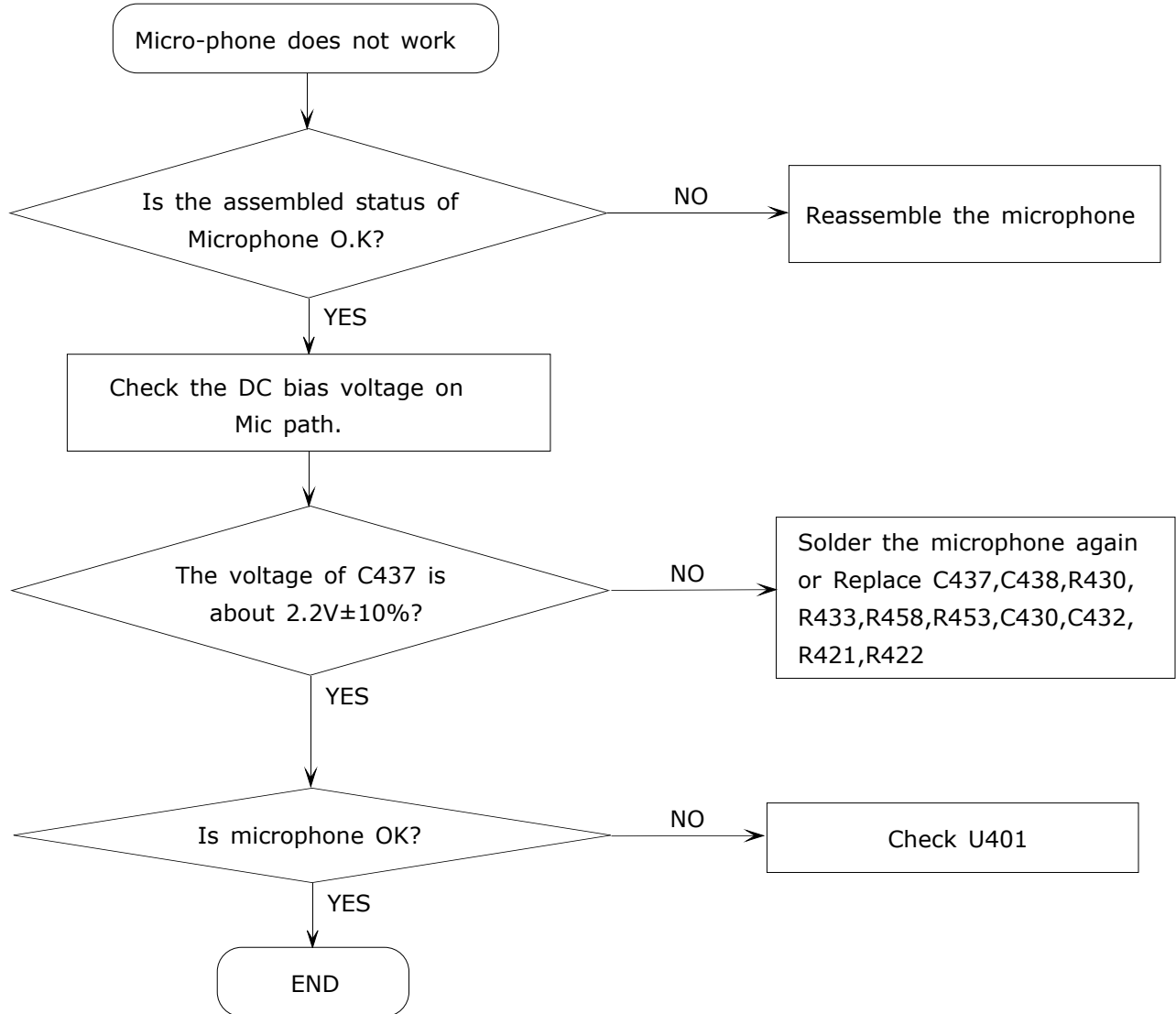

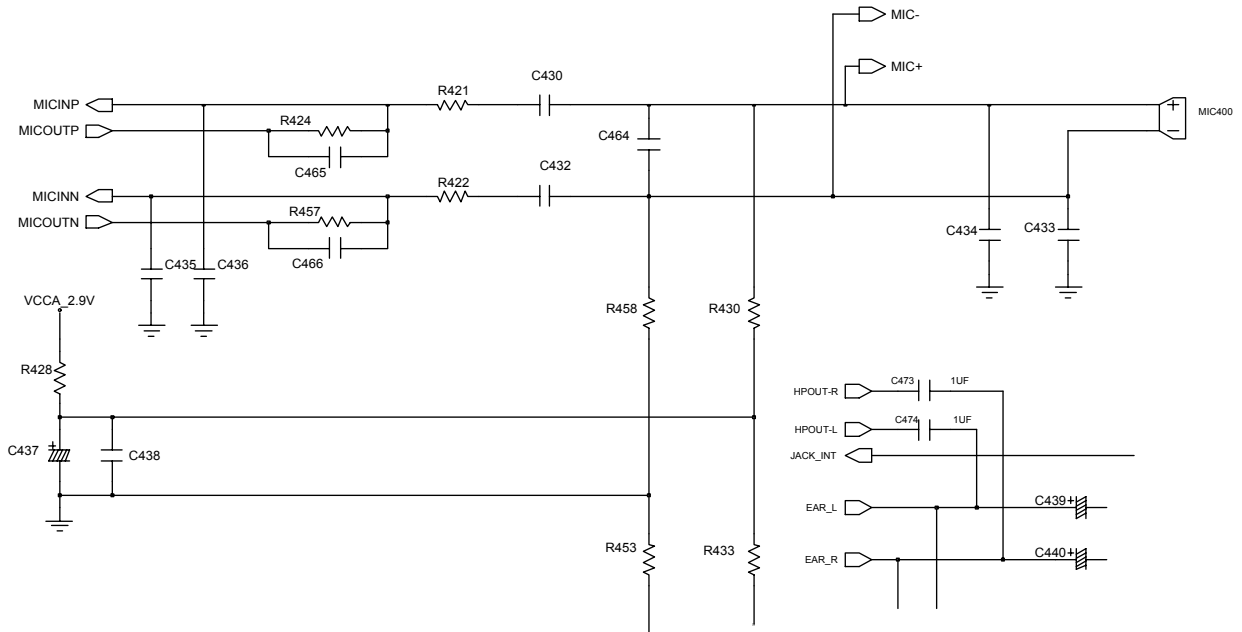
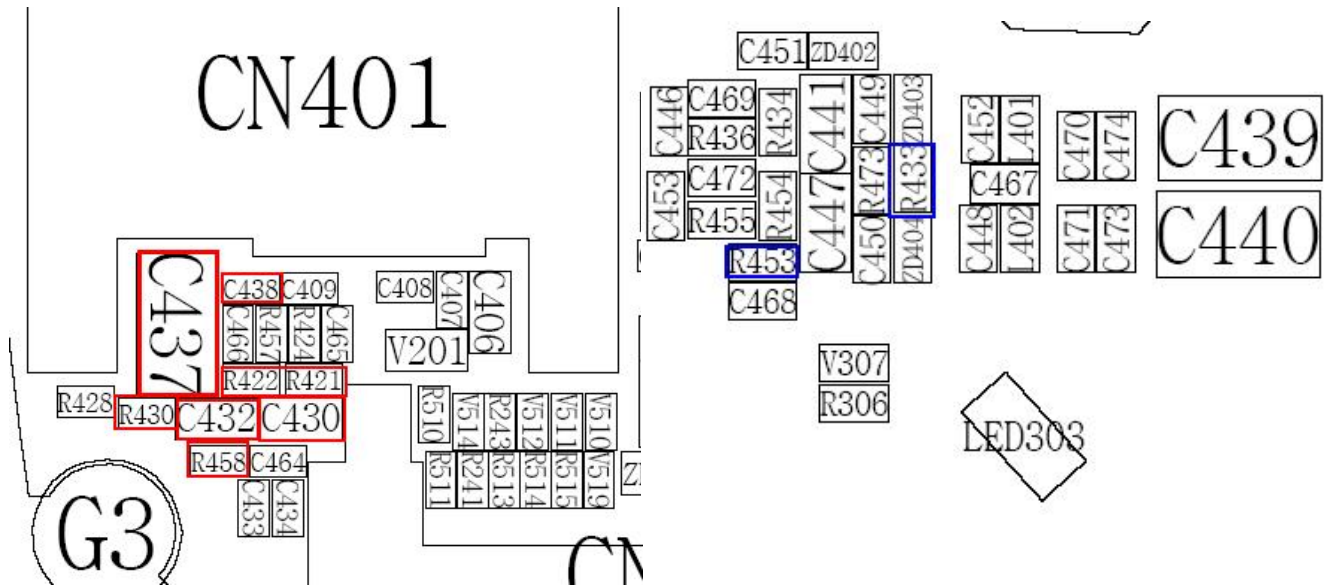

2-1-5. Speaker Part

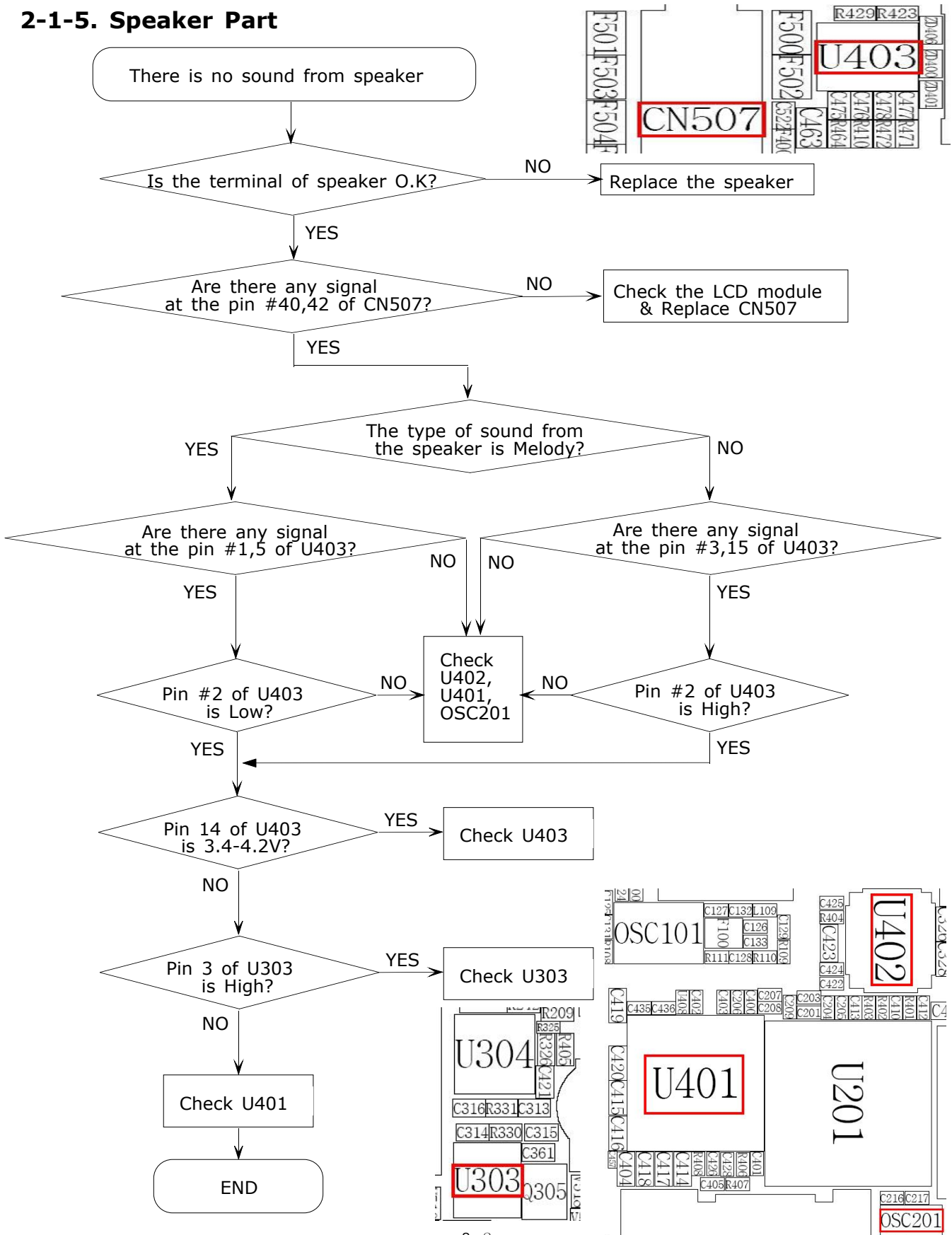

2-1-6. Camera Part

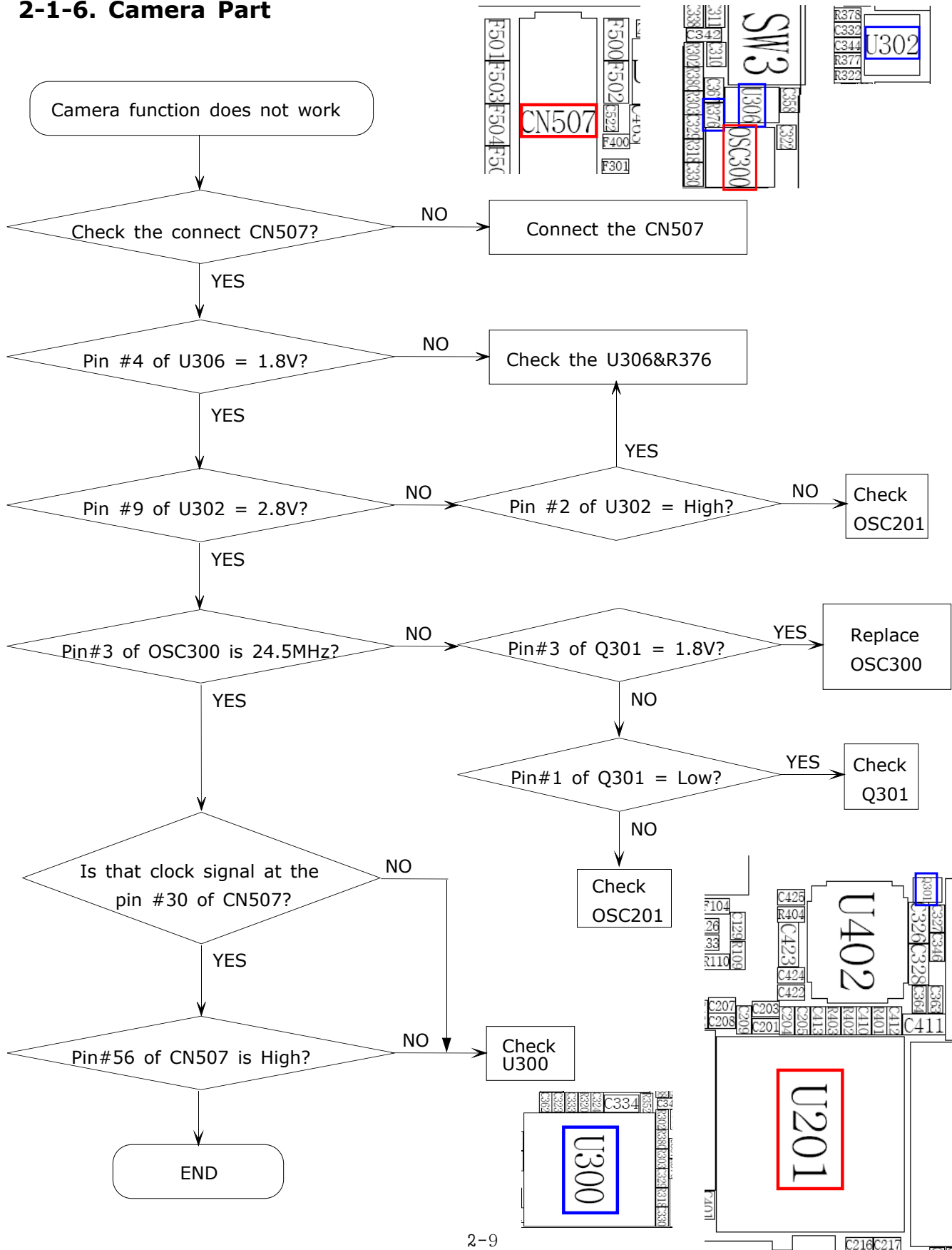

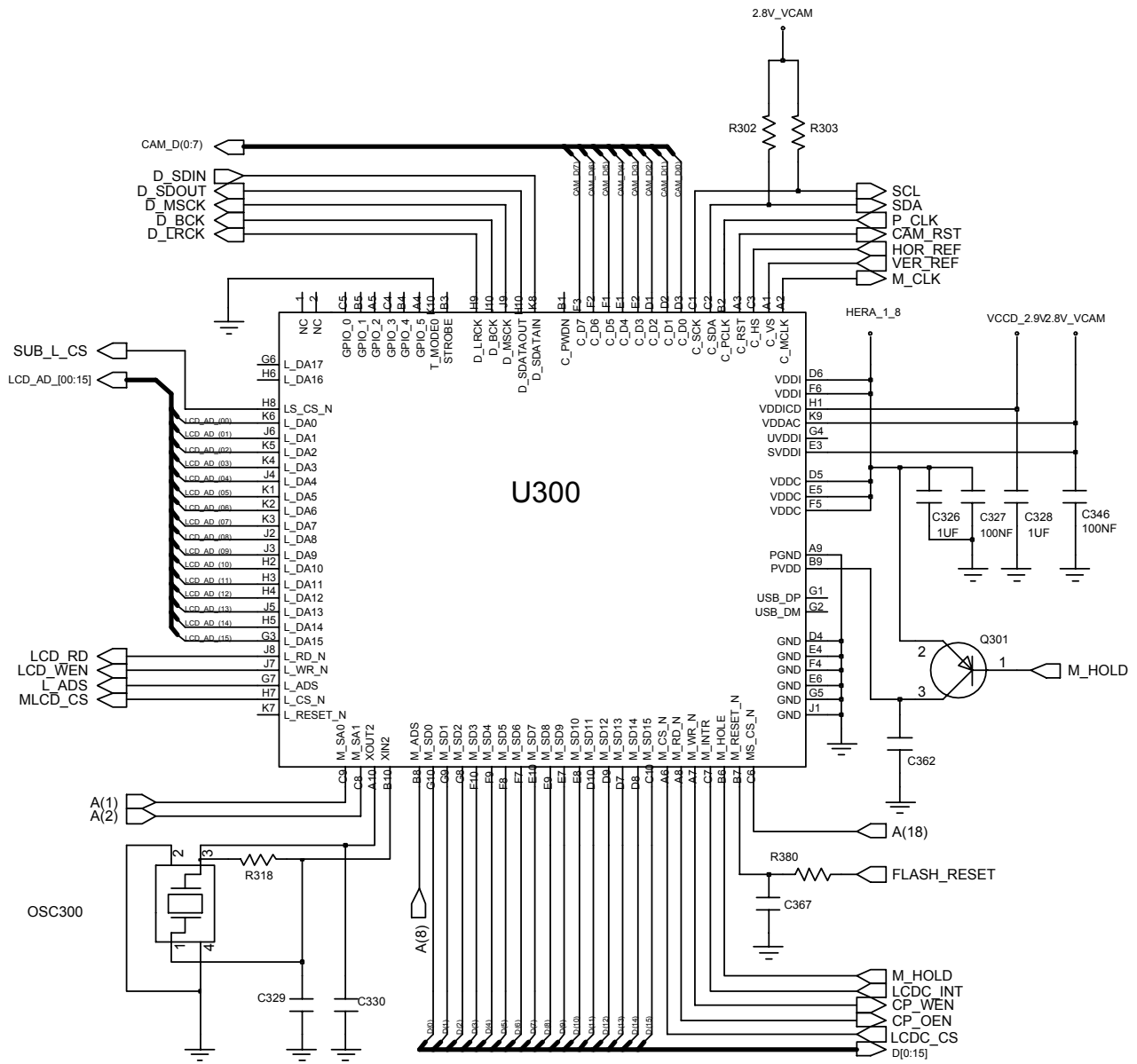

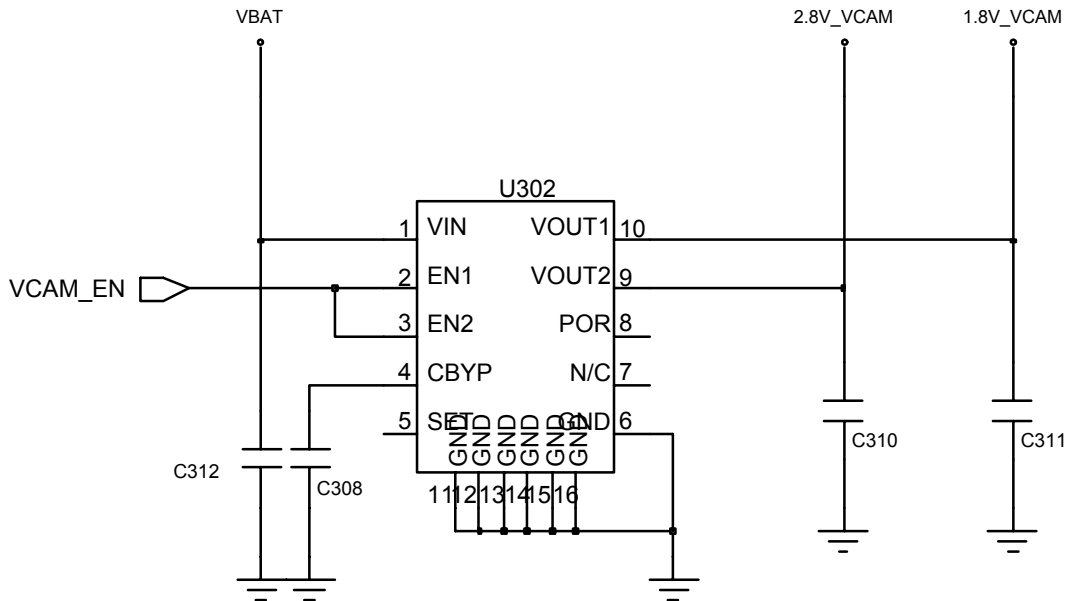
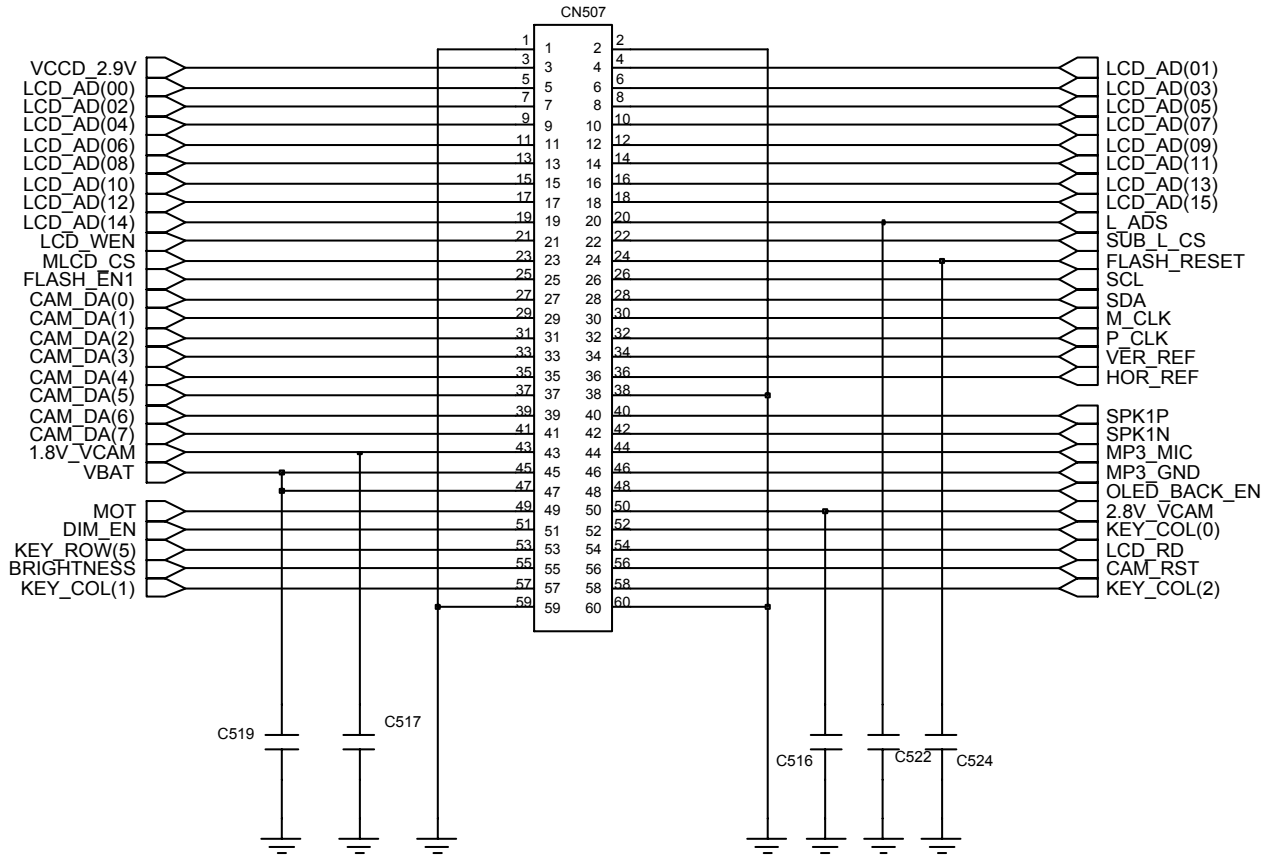

2-1-7. Mp3 Display Part

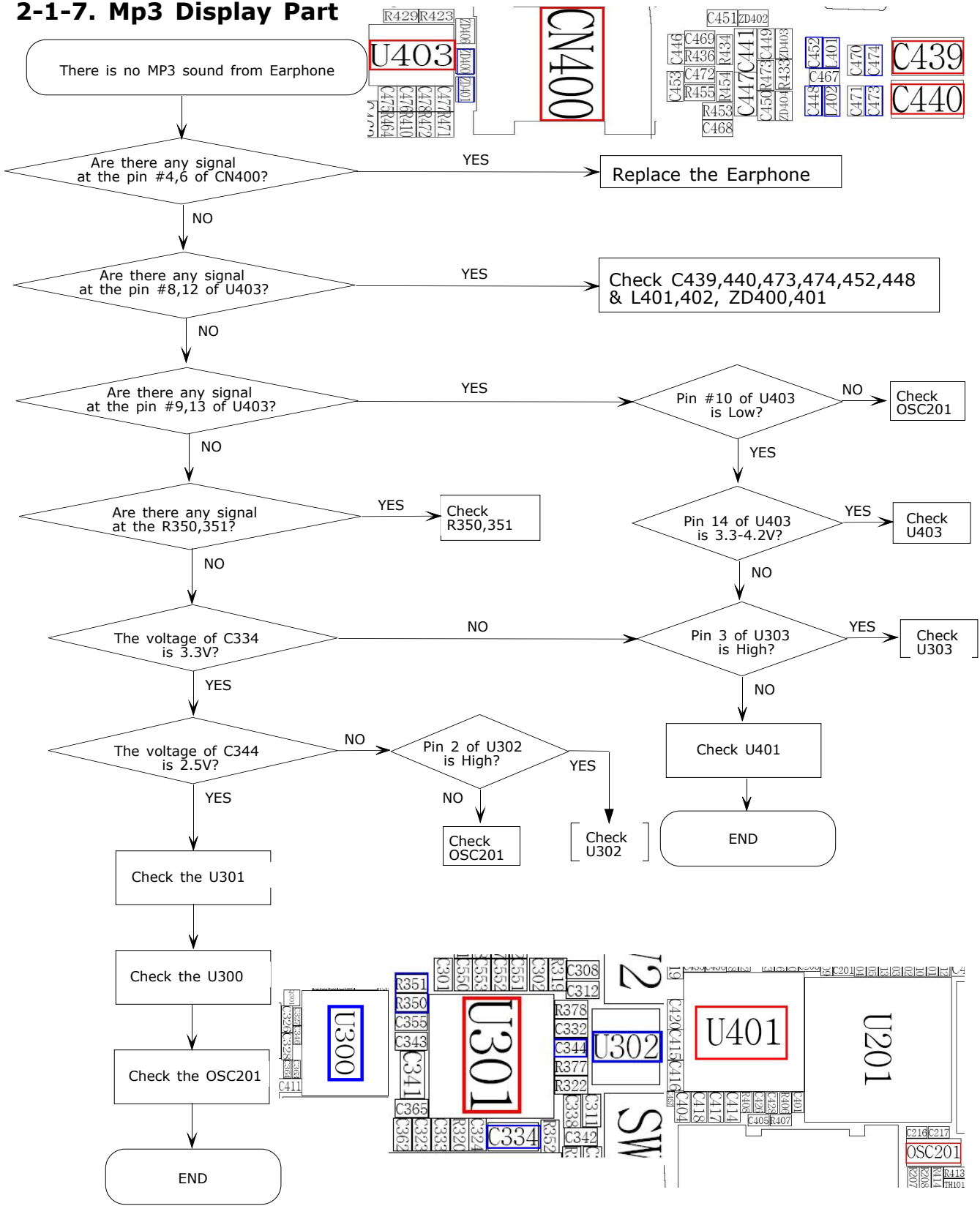

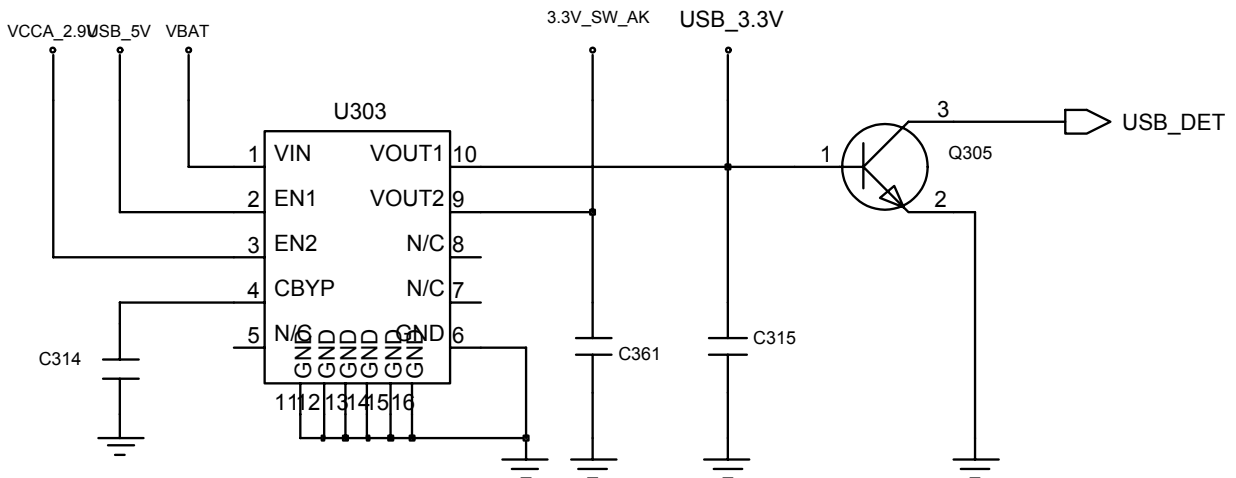
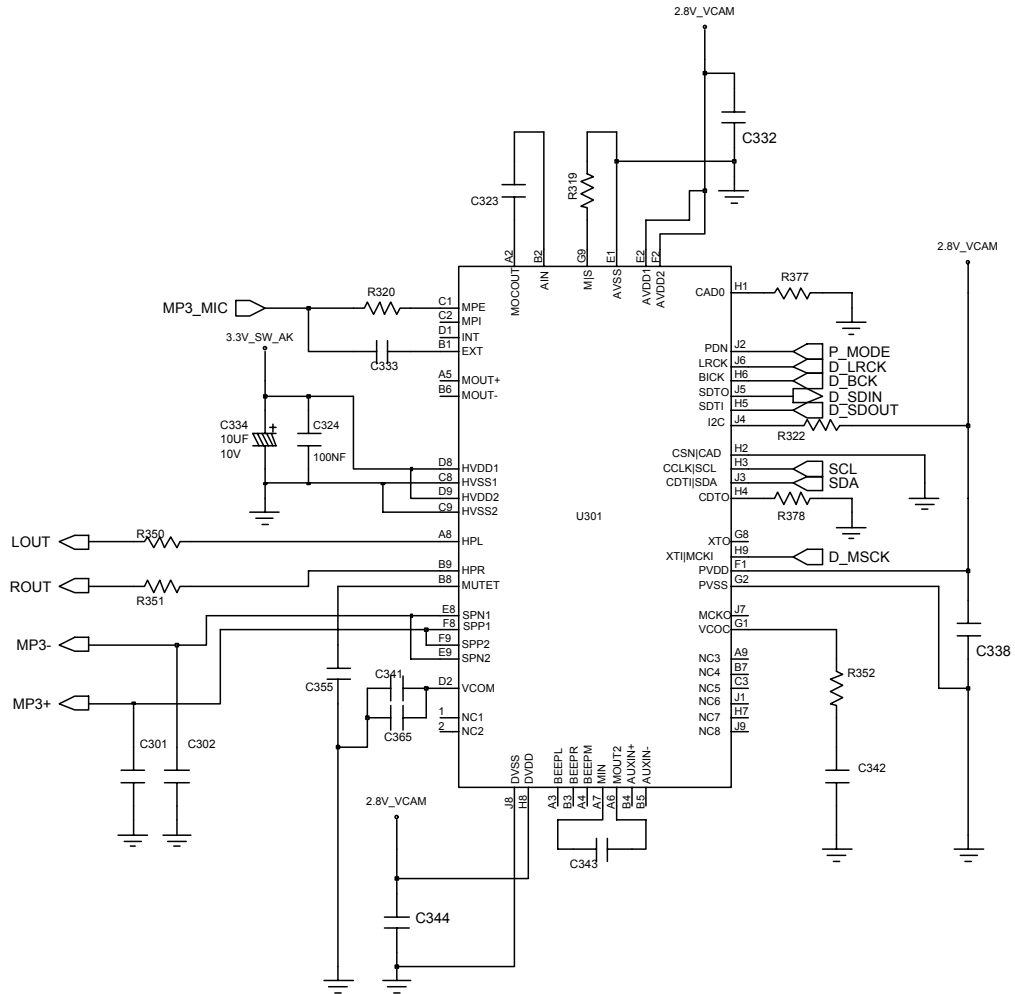

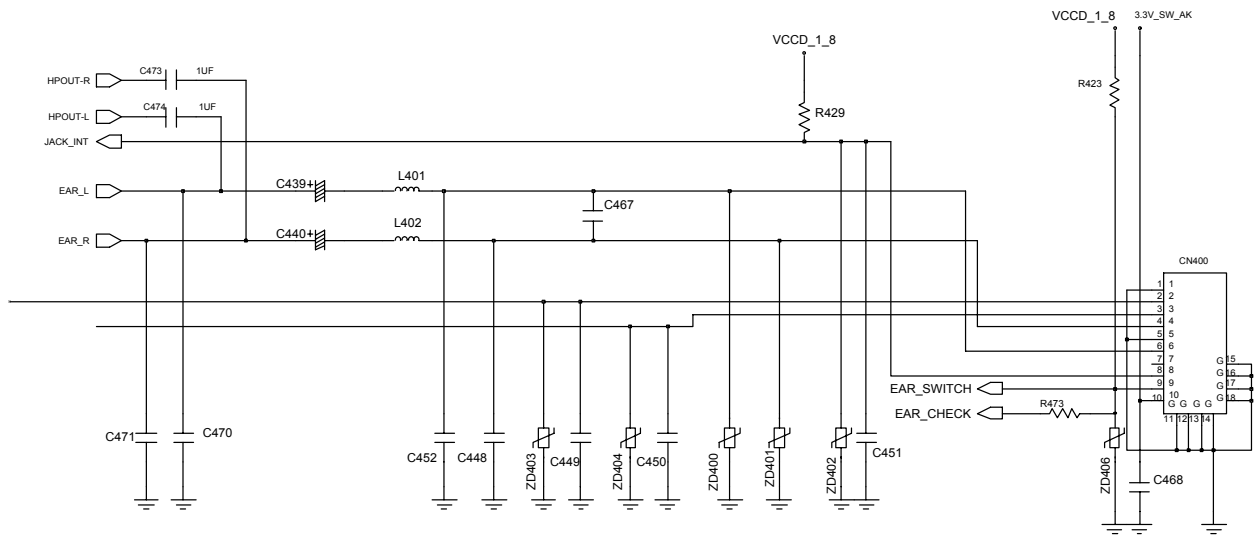
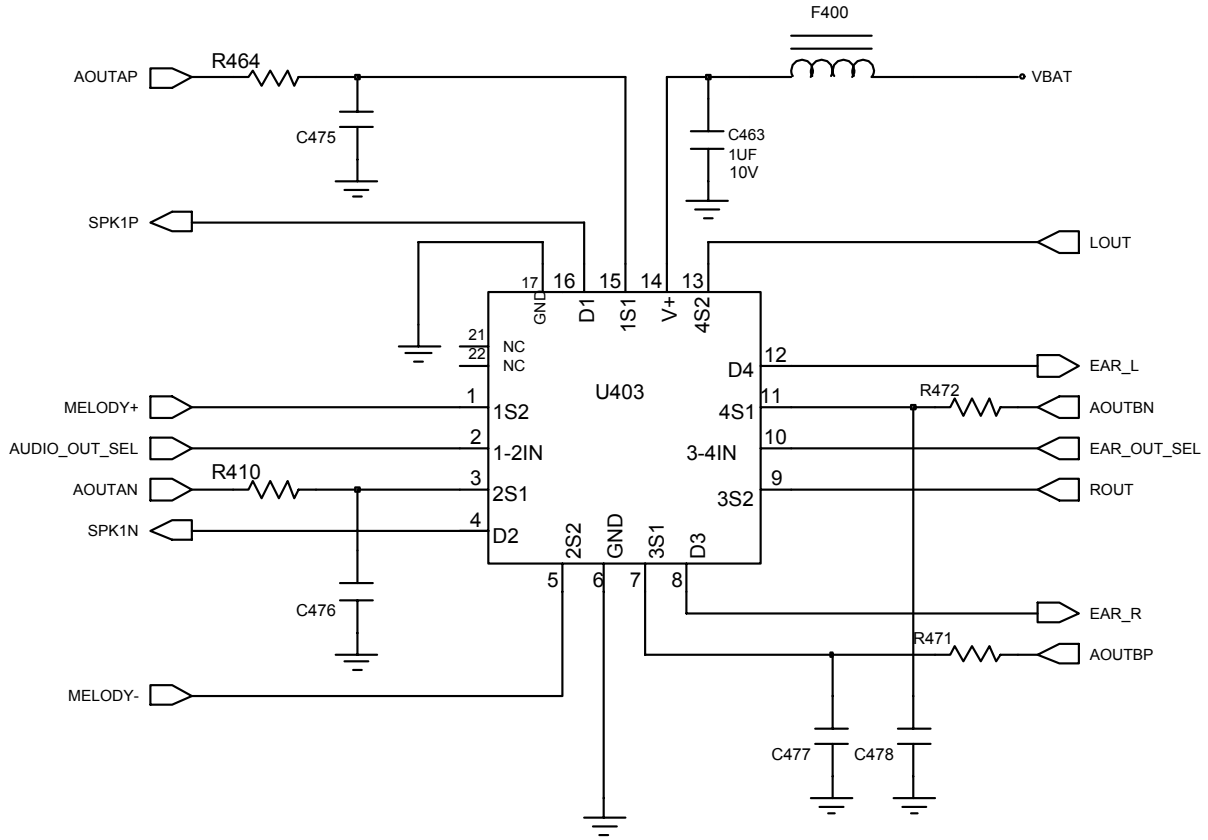

2-2.RF

2-2-1. EGSM RX

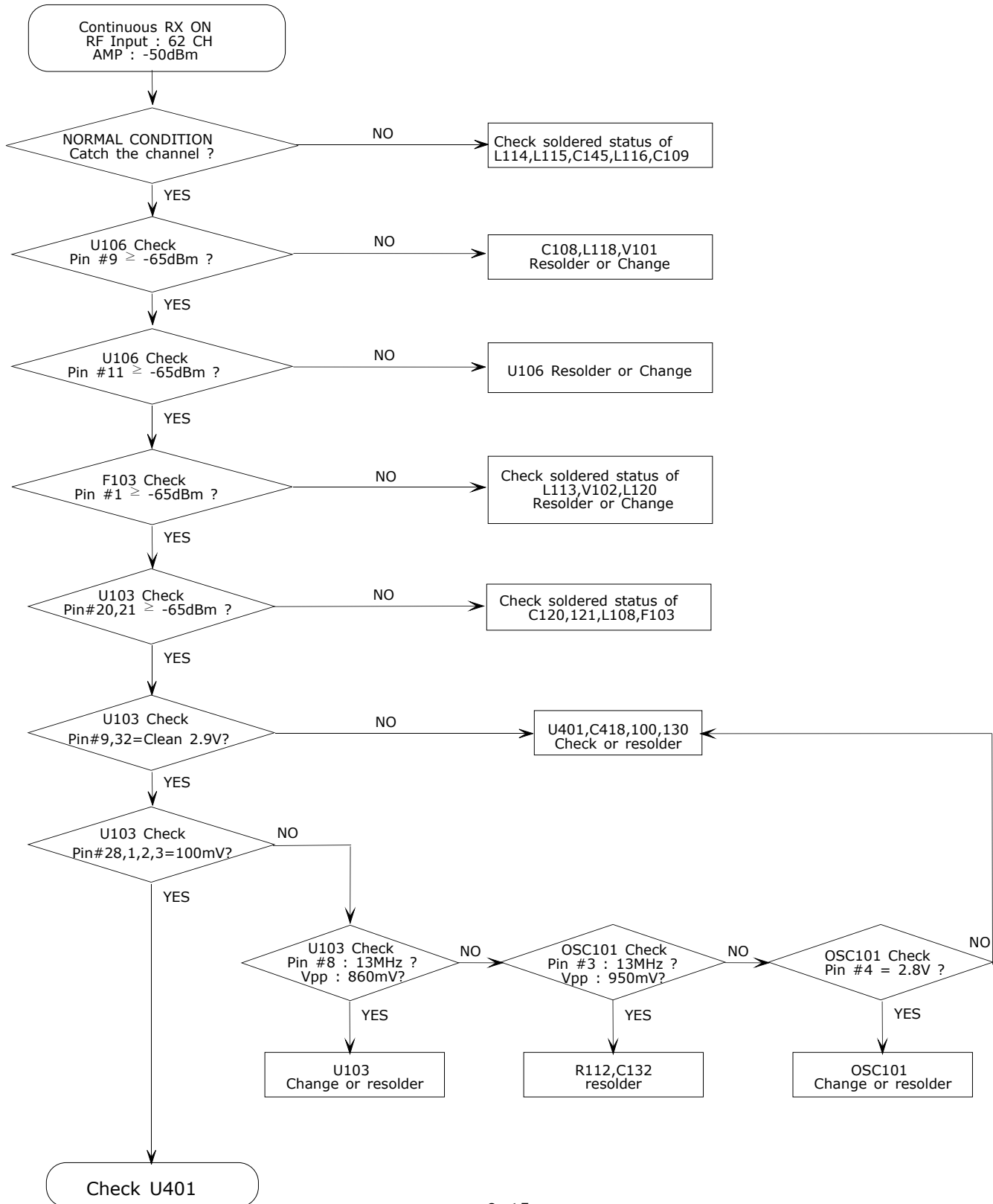

2-2-2. DCS RX

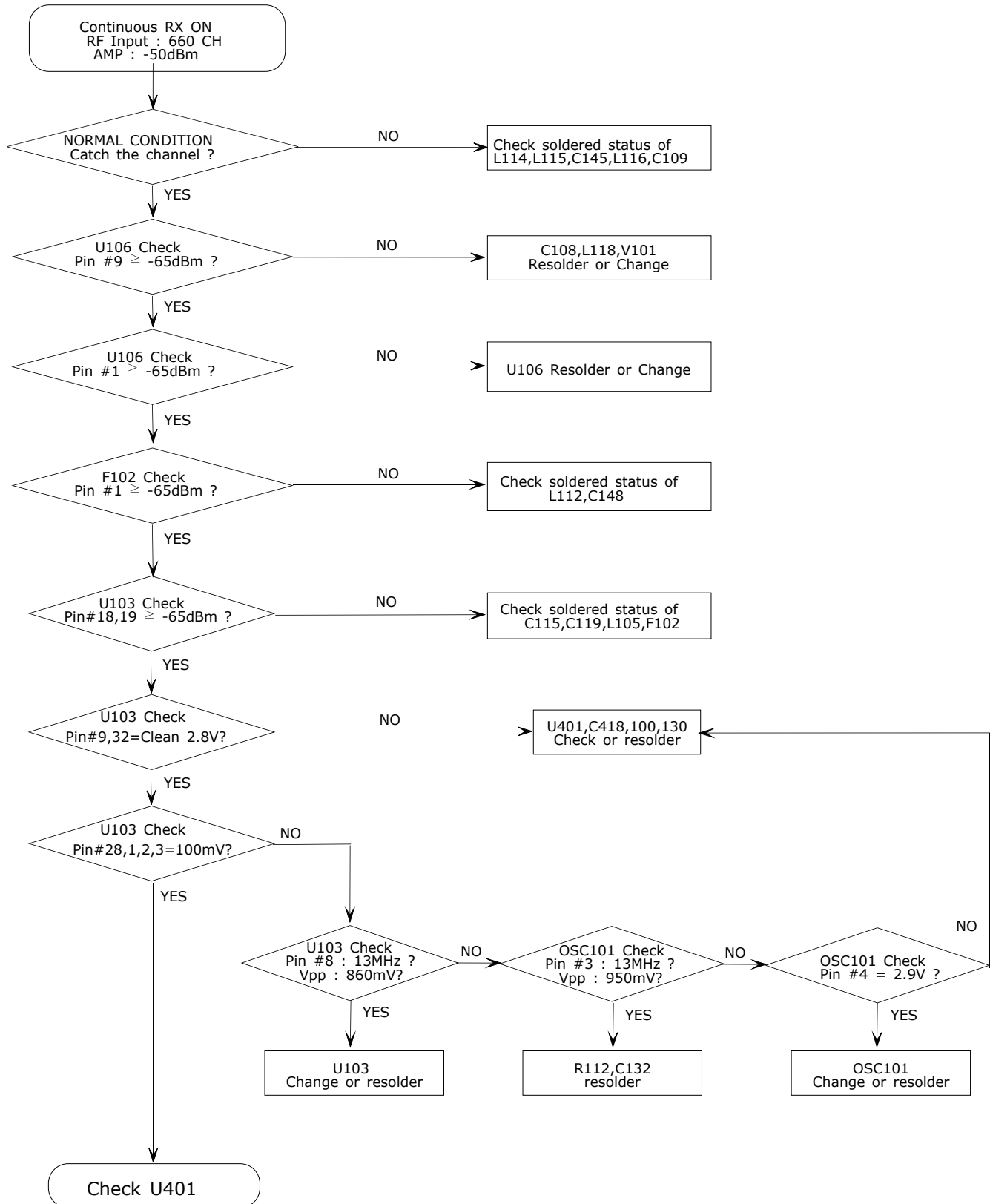

2-2-3. PCS RX

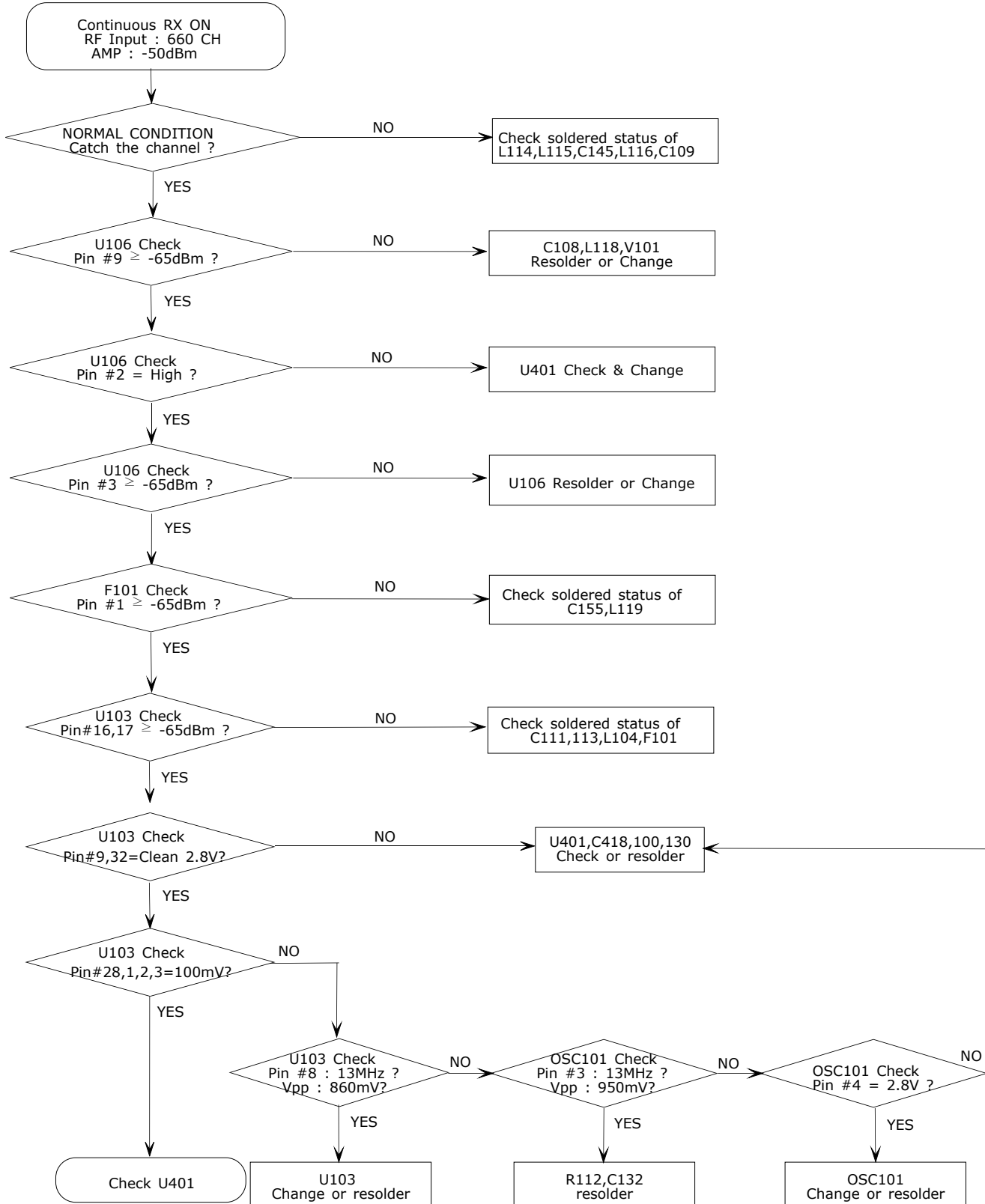

2-2-4. EGSM TX

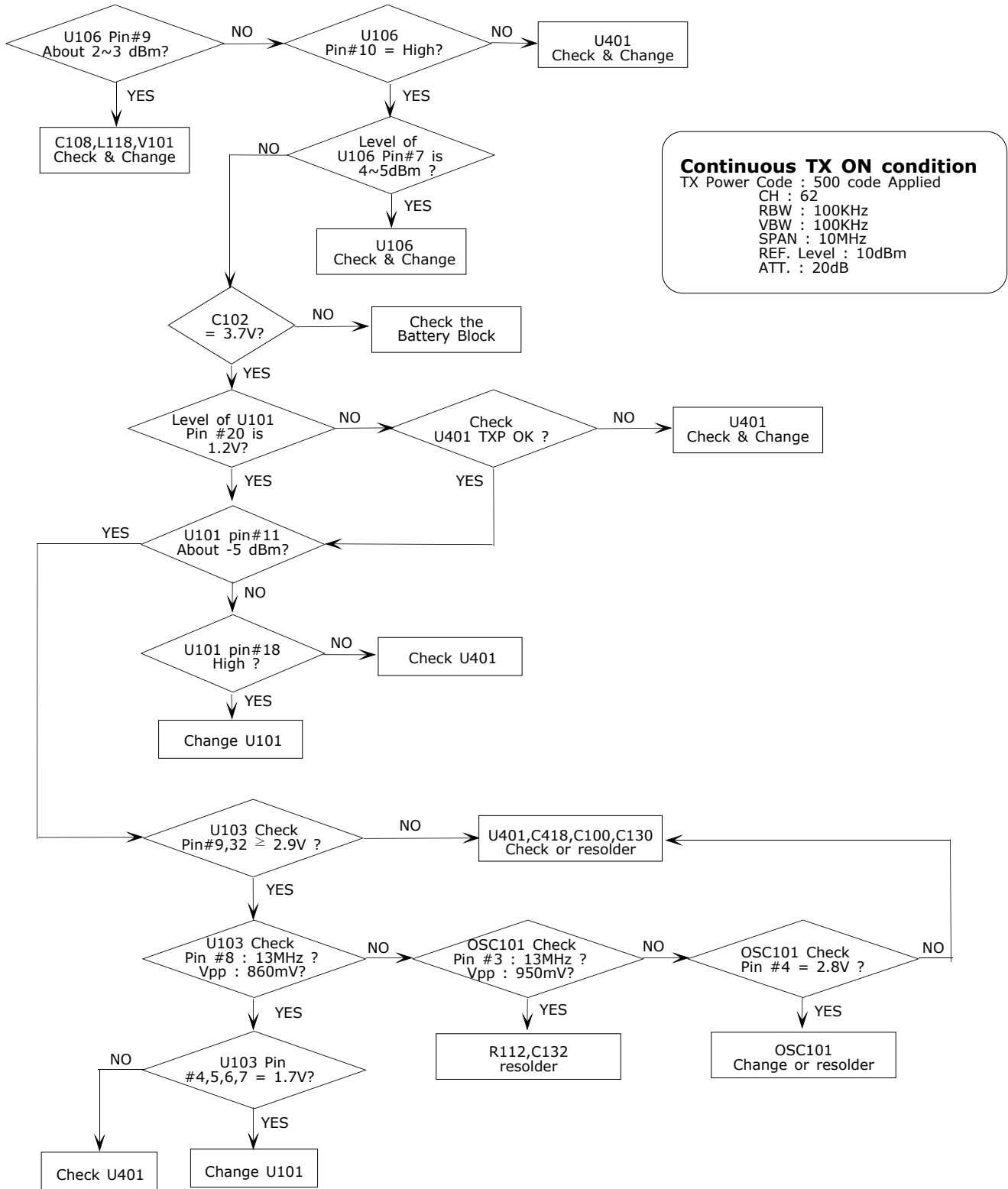

Continuous TX ON condition
 TX Power Code : 500 code Applied
 CH : 62
 RBW : 100KHz
 VBW : 100KHz
 SPAN : 10MHz
 REF. Level : 10dBm
 ATT. : 20dB

2-2-5. DCS & PCS TX

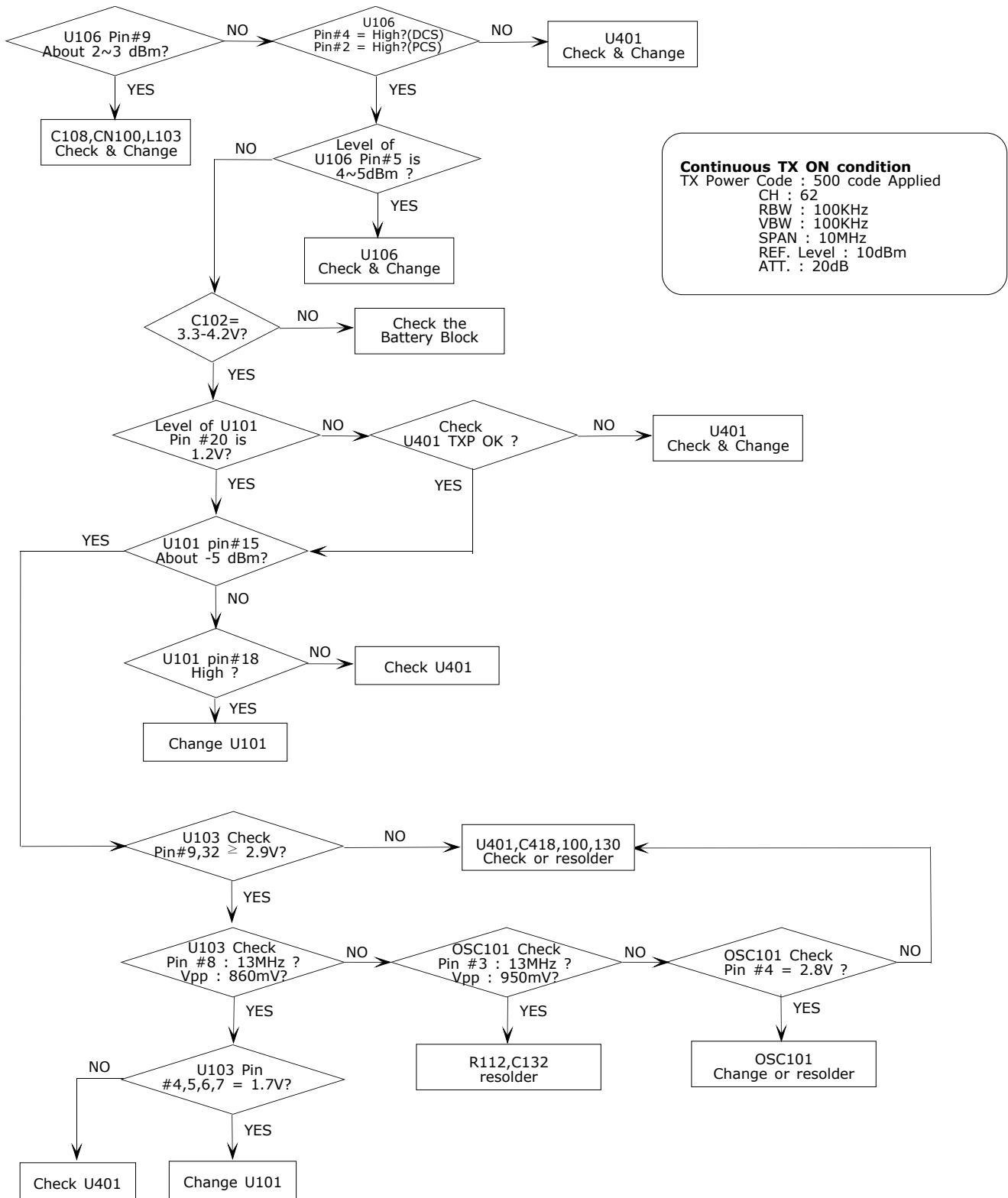

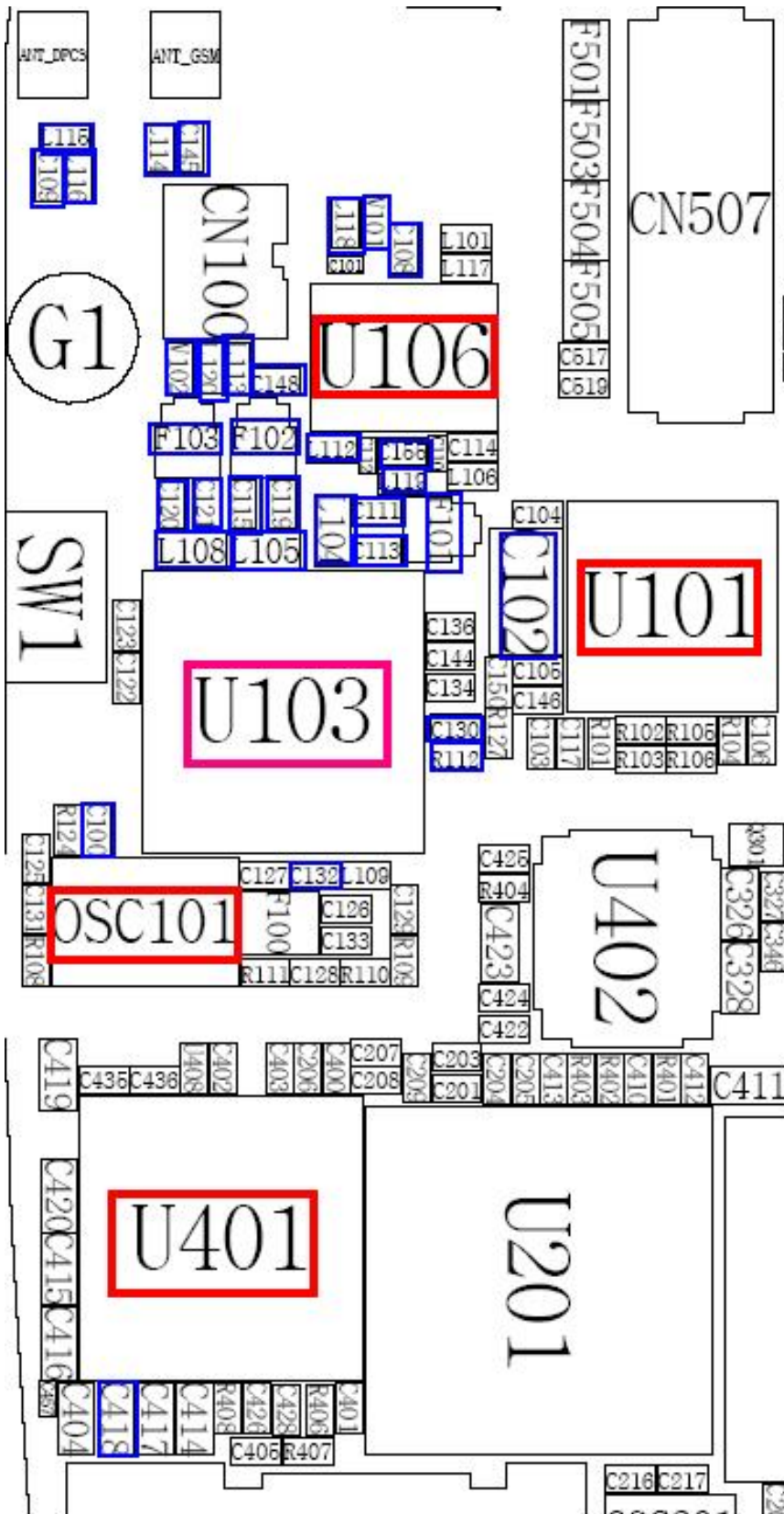

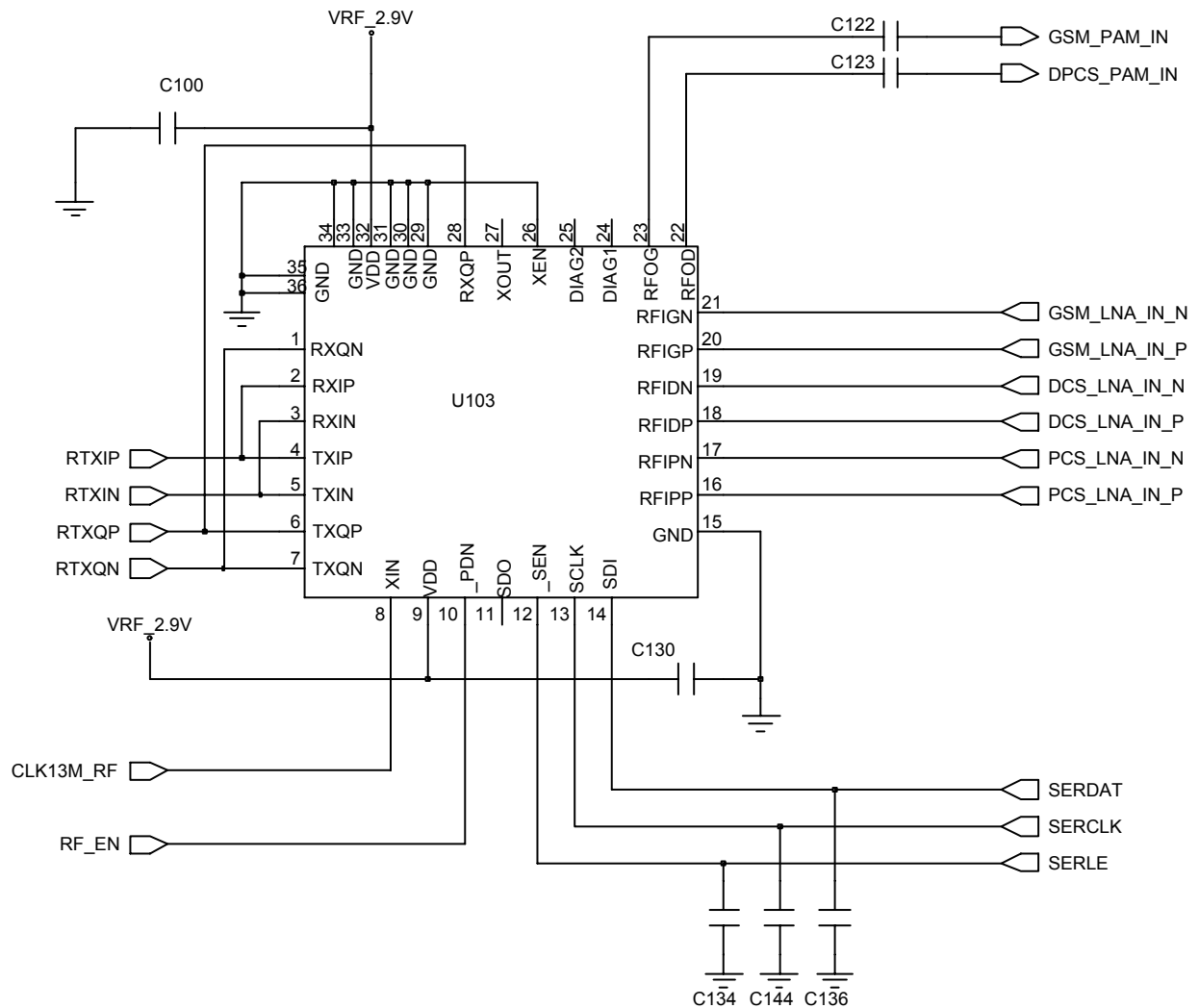
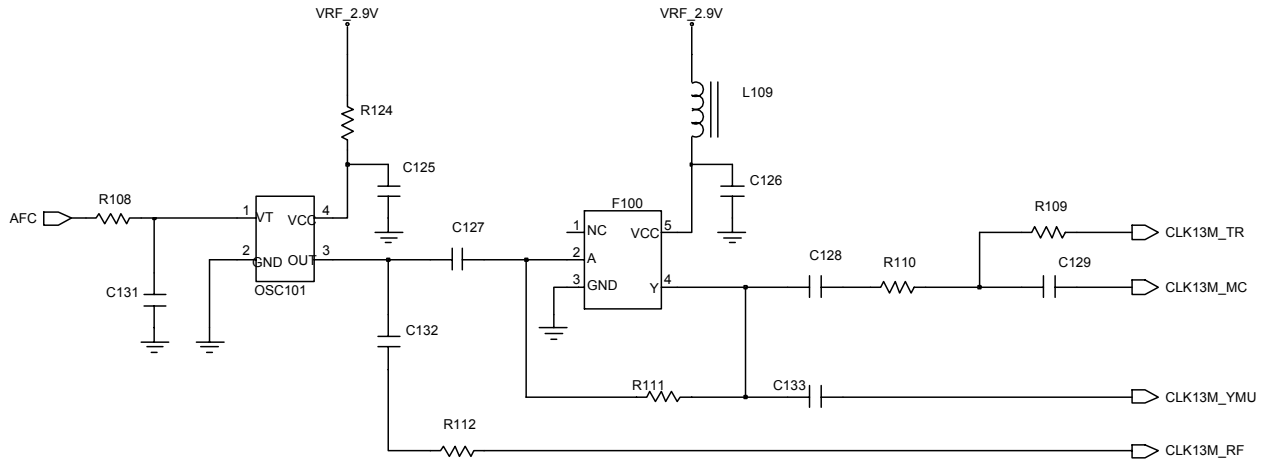

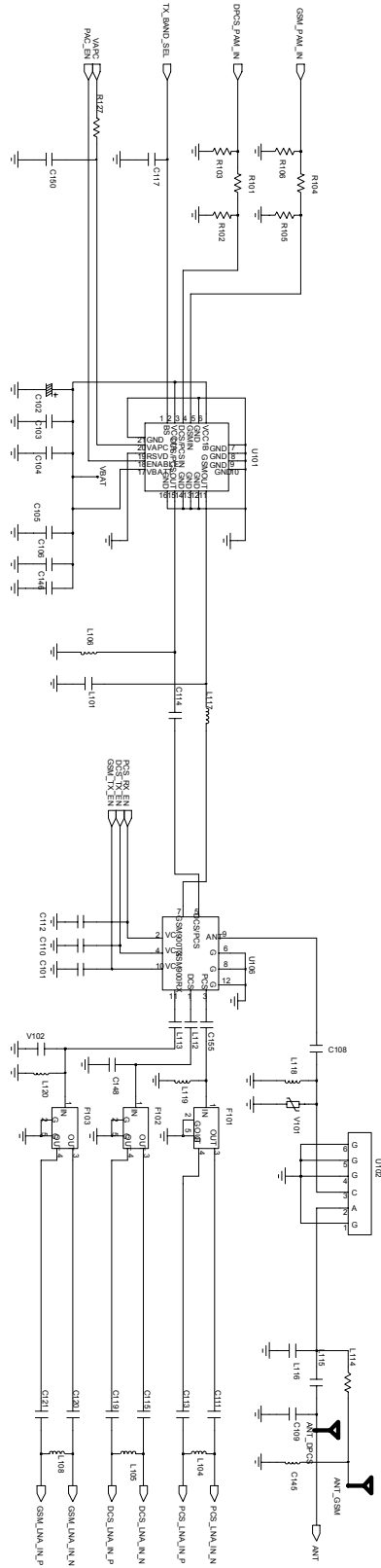

3. SGH-S410i Exploded View and Parts List

3-1. Cellular phone Exploded View

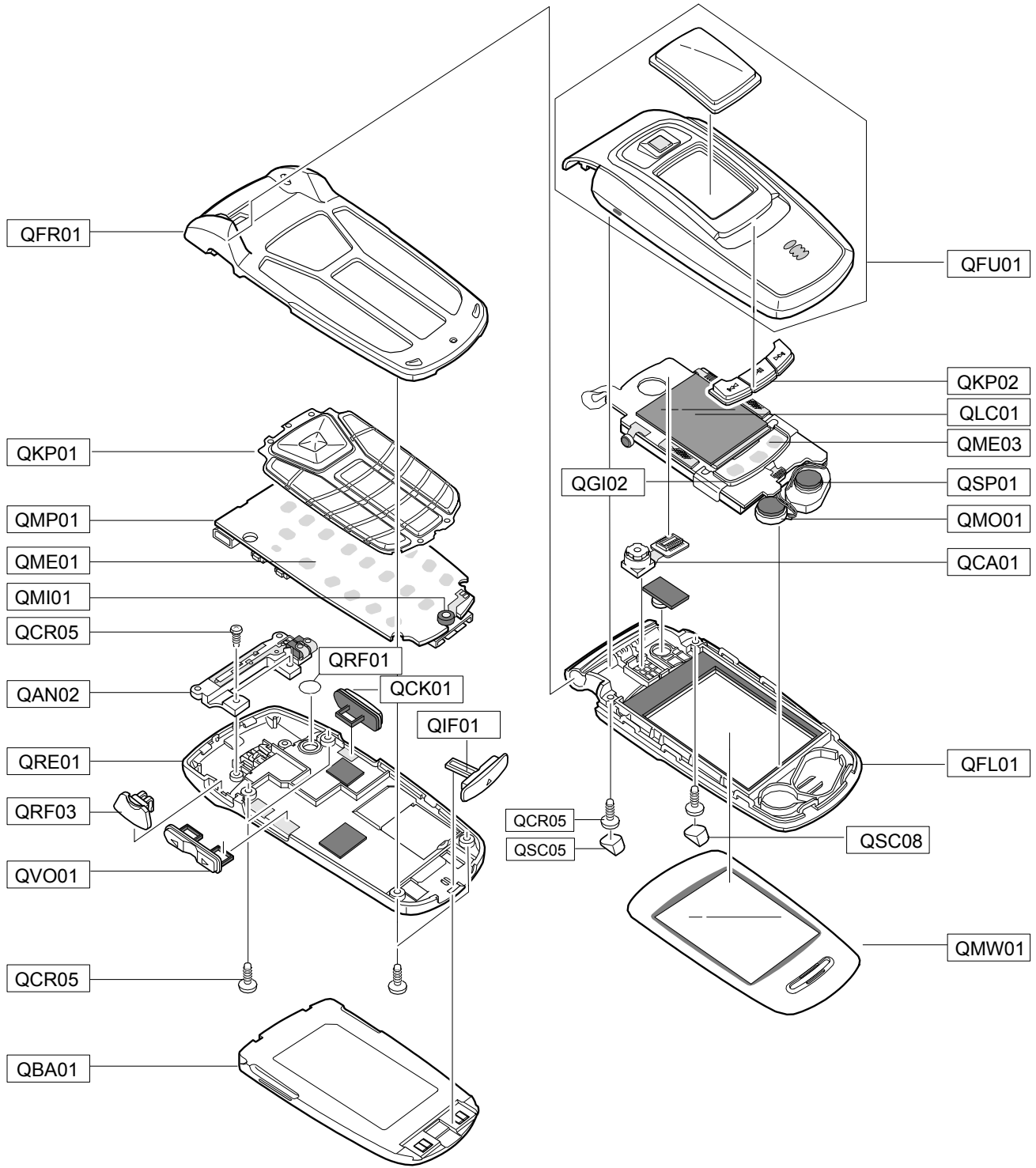

3-2. Cellular phone Parts list

Location No		Description	Sec code
QAN02		INTENNA-SGHE720;EWPADF003A,SGH-E720,	GH42-00499A
QAN05		RMO-RUBBER INTENNA;SGH-E720,CR RUBBE	GH73-04456A
QBA01		BATTERY-800MAH,SIL,ENG,M;BST3408SV,S	GH43-01794A
QCA01		UNIT-CAMERA;SGH-S410i,MOMFH330G1A,-,	GH59-02052A
QCK01		MEC-KEY CAMERA;SGH-E720,SEC,-,-,SIL,	GH75-05918A
QCR05		SCREW-MACHINE;PH,+ ,M1.4,L3,ZPC(BLK),	6001-001478
QFL01		MEC-FOLDER LOWER;SGH-S410i,EU,-,-,SI	GH75-06556A
QFR01		MEC-FRONT COVER;SGH-S410i,EU,-,-,SIL	GH75-05913E
QFU01		MEC-SUA FOLDER UPPER;SGH-S410i,WIND,	GH75-07027A
QGI02		PMO-MP3 KEY BRACKET;SGH-E720,PC,GRY,	GH72-20060A
QIF01		PMO-IF COVER;SGH-S410i,PC+URETHAN,SI	GH72-17956E
QKP01		MEC-KEYPAD MAIN;SGH-S410i,EU,-,-,SIL	GH75-06558A
QKP02		MEC-KEY FOLD(MP3);SGH-S410i,EU,-,-,S	GH75-06564A
QLC01		LCD-MODULE SGHS410I;UF-17E103-A,SGH-	GH07-00693A
QME01		UNIT-METAL DOME;SGH-S410i,9KW9589-01	GH59-02062A
QME03		UNIT-MP3 KEY;SGH-S410i,9MK9589-01001	GH59-02068A
QMI01		MICROPHONE-ASSY;2.0,130~500uA,-44dB,	GH30-00185A
QMO01		MOTOR DC-SGHE720;DMJBRK20F,SGH-E720,	GH31-00136A
QMP01		PBA MAIN-SGHS410I;SGH-S410i,BOG,EU,P	GH92-02024A
QMW01		MEC-MAIN WINDOW;SGH-S410i,EU,-,-,SIL	GH75-06559A
QRE01		MEC-REAR COVER;SGH-S410i,EU,-,-,SIL,	GH75-05919E
	QRF03	PMO-EAR JACK COVER;SGH-S410i,PC+URET	GH72-17957E
QRF01		MPR-RF SHEET;SGH-S410i,PC SHEET,PI5.	GH74-11931E
QSC05		RMO-F/LOWER SCREW CAP L;SGH-E720,NR	GH73-03810B
QSC08		RMO-F/LOWER SCREW CAP R;SGH-E720,NR	GH73-03811B
QVO01		MEC-KEY VOLUME;SGH-E720,SEC,-,-,SIL,	GH75-05917A
QSP01		SPEAKER;0.5W,8ohm,89dB,800Hz,17.3X13	3001-001755

Description	Sec code
BAG PE;LDPE,T0.05,W80,L180,TRP,-,-	6902-000634
CHARGER-TCH;TCH137ESE,SGH-X910,AC/DC	GH44-00701A
UNIT-EARPHONE;SGH-X910,AEP277SSE,-,E	GH59-01392A
SPRING ETC-SPRING BATT LOCKER;SGHE70	GH61-00047A
LABEL(P)-WATER SOAK;SCH-X110,NORGE,1	GH68-02026A
MANUAL-GAME;SGH-S341I,COS,GREEK,GREE	GH68-05658A
MANUAL-USE;SGH-S410i,WIN,ITALIAN,ITA	GH68-06987A
MANUAL-WEEE CARD;SGH-E720,SEC,ENGLIS	GH68-07013A
LABEL(R)-MAIN WIND;SGH-S410i,-,MAT,T	GH68-07027B
CUSHION-CASE;SGH-E720,PULP,T1.0,133,	GH69-02712A
BOX(P)-UNIT MAIN;SGH-S410i,SC300+F(K	GH69-02932A
MPR-EMI MASKING SHEET;SCH-X720,TAPE,	GH74-03317A
MPR-CUSHION MOTOR;SGH-E720,PORON,PI9	GH74-11916A
MPR-BOHO VINYL SUB WIN;SGH-E700,STA	GH74-12175A
MPR-MIC SHEET;SGH-E720,INSULATION,4.	GH74-12505A
MPR-SHEET PBA;SGH-E720,INSULATION,10	GH74-13227A
MPR-TAPE FPCB HOLE;SGH-S410i,PET-N17	GH74-13495A
MPR-BOHO VINYL F/U;SGH-S410i,SP-600,	GH74-13536A
MPR-BOHO VINYL IF;SGH-E720,#950,85X1	GH74-13606A
MPR-BOHO VINYL REAR;SGH-E720,SP-600,	GH74-14335A
MPR-SHEET ANT CONTACT;SGH-E720,INSUL	GH74-14456A
MPR-LCD FRA SHIELD TAPE;SGH-S410i,SH	GH74-14688A
MPR-SUB LCD GASKET;SGH-S410i,SHIELD,	GH74-14691A
MPR-CONN GASKET;SGH-S410i,SHIELD,7.5	GH74-14692A
MPR-BOHO VINYL MAIN LCD;SGH-S410i,SP	GH74-14693A
MPR-KEY GROUND SHEET;SGH-S410i,SHIEL	GH74-14694A
MPR-MPR SHEET B;SGH-S410I,SP-65,2X9X	GH74-15278A
MPR-BOHO VINYL LCD B;SGH-S410I,3M-41	GH74-15295A
MPR-PBA MSK PORON;SGH-S410i,SRS PORO	GH74-15942A
MEC-EPOXY FINGER RING;SGH-E800,EU,ZN	GH75-04766A
MEC-FOLDER DUMMY;SGH-S410i,WIND,-,-,	GH75-07026A

3-3. Test Jig (GH80-03307A)



3-3-1. RF Test Cable
(GH39-00283A)



3-3-2. Test Cable
(GH39-00304A)



3-3-3. Serial Cable



3-3-4. Power Supply Cable

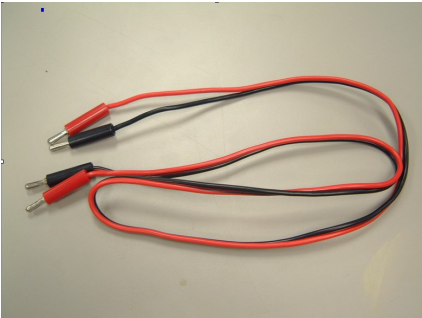

3-3-5. Data Cable
(GH39-00279A)

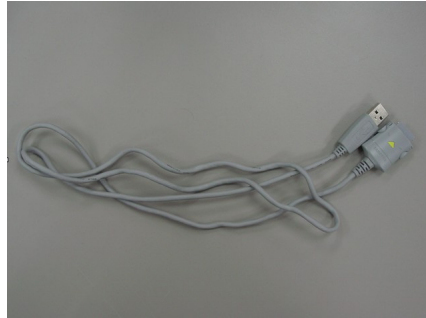

3-3-6. TC (GH44-00701A)



4. SGH-S410i MAIN Electrical Parts List

SEC CODE	Design LOC	Discription	SEC CODE	Design LOC	Discription
GH92-02024A	PBA	PBA MAIN-SGHS410I	2203-000278	C125	C-CER,CHIP
0403-001547	ZD500	DIODE-ZENER	2203-000278	C329	C-CER,CHIP
0504-000168	Q305	TR-DIGITAL	2203-000278	C330	C-CER,CHIP
0504-001140	Q200	TR-DIGITAL	2203-000278	V102	C-CER,CHIP
0504-001140	Q301	TR-DIGITAL	2203-000311	C150	C-CER,CHIP
0601-001819	LED301	LED	2203-000330	C477	C-CER,CHIP
0601-001819	LED302	LED	2203-000330	C478	C-CER,CHIP
0601-001819	LED303	LED	2203-000386	C114	C-CER,CHIP
0601-001819	LED304	LED	2203-000425	C216	C-CER,CHIP
0601-001819	LED308	LED	2203-000425	C217	C-CER,CHIP
0601-001819	LED309	LED	2203-000438	C126	C-CER,CHIP
0601-001819	LED310	LED	2203-000438	C127	C-CER,CHIP
0601-001819	LED311	LED	2203-000438	C425	C-CER,CHIP
0601-001819	LED312	LED	2203-000438	C545	C-CER,CHIP
0601-001819	LED313	LED	2203-000438	C546	C-CER,CHIP
0601-001819	LED314	LED	2203-000628	L112	C-CER,CHIP
0601-001819	LED315	LED	2203-000643	C155	C-CER,CHIP
0601-001819	LED316	LED	2203-000654	C410	C-CER,CHIP
0601-001819	LED317	LED	2203-000812	C117	C-CER,CHIP
0801-000306	F100	IC-CMOS LOGIC	2203-000812	C123	C-CER,CHIP
0801-002529	U204	IC-CMOS LOGIC	2203-000812	C405	C-CER,CHIP
0801-002975	U308	IC-CMOS LOGIC	2203-000812	C408	C-CER,CHIP
1001-001306	U403	IC-ANALOG MULTIPLEX	2203-000812	C409	C-CER,CHIP
1006-001313	U304	IC-BUS TRANSCEIVER	2203-000812	C433	C-CER,CHIP
1009-001010	U203	IC-HALL EFFECT S/W	2203-000812	C434	C-CER,CHIP
1108-000003	U202	IC-MCP	2203-000812	C470	C-CER,CHIP
1201-002218	U101	IC-POWER AMP	2203-000812	C471	C-CER,CHIP
1201-002233	U307	IC-AUDIO AMP	2203-000812	C522	C-CER,CHIP
1203-002965	U303	IC-MULTI REG.	2203-000836	C448	C-CER,CHIP
1203-002969	U302	IC-MULTI REG.	2203-000836	C452	C-CER,CHIP
1203-003208	U107	IC-POSI.FIXED REG.	2203-000836	C465	C-CER,CHIP
1203-003472	U401	IC-POWER SUPERVISOR	2203-000836	C466	C-CER,CHIP
1203-003611	U306	IC-POSI.FIXED REG.	2203-000836	C469	C-CER,CHIP
1204-002138	U402	IC-MELODY	2203-000836	C472	C-CER,CHIP
1205-002433	U103	IC-TRANSCEIVER	2203-000854	C435	C-CER,CHIP

SGH-S410i Main Electrical Parts List

SEC CODE	Design LOC	Discription
1205-002612	U300	IC-CODEC
1205-002613	U301	IC-CODEC
1404-001165	TH101	THERMISTOR-NTC
1405-001018	V201	VARISTOR
1405-001018	ZD405	VARISTOR
1405-001082	V301	VARISTOR
1405-001082	V302	VARISTOR
1405-001082	V303	VARISTOR
1405-001082	V304	VARISTOR
1405-001082	V305	VARISTOR
1405-001082	V306	VARISTOR
1405-001082	V307	VARISTOR
1405-001082	V308	VARISTOR
1405-001082	V309	VARISTOR
1405-001082	V310	VARISTOR
1405-001082	V311	VARISTOR
1405-001082	V502	VARISTOR
1405-001082	V503	VARISTOR
1405-001082	V504	VARISTOR
1405-001082	V505	VARISTOR
1405-001082	V506	VARISTOR
1405-001082	V507	VARISTOR
1405-001082	V510	VARISTOR
1405-001082	V511	VARISTOR
1405-001082	V512	VARISTOR
1405-001082	V514	VARISTOR
1405-001082	V518	VARISTOR
1405-001082	V519	VARISTOR
1405-001082	ZD400	VARISTOR
1405-001082	ZD401	VARISTOR
1405-001082	ZD402	VARISTOR
1405-001082	ZD403	VARISTOR
1405-001082	ZD404	VARISTOR
1405-001082	ZD406	VARISTOR
1405-001132	V101	VARISTOR

SEC CODE	Design LOC	Discription
2203-000854	C436	C-CER,CHIP
2203-000854	C446	C-CER,CHIP
2203-000854	C453	C-CER,CHIP
2203-000854	C475	C-CER,CHIP
2203-000854	C476	C-CER,CHIP
2203-000885	C342	C-CER,CHIP
2203-000995	C122	C-CER,CHIP
2203-000995	C211	C-CER,CHIP
2203-000995	L113	C-CER,CHIP
2203-001239	C449	C-CER,CHIP
2203-001239	C450	C-CER,CHIP
2203-001405	C130	C-CER,CHIP
2203-001405	C413	C-CER,CHIP
2203-001405	C456	C-CER,CHIP
2203-002668	L101	C-CER,CHIP
2203-002759	C550	C-CER,CHIP
2203-002759	C551	C-CER,CHIP
2203-002987	C108	C-CER,CHIP
2203-005061	C100	C-CER,CHIP
2203-005061	C220	C-CER,CHIP
2203-005061	C221	C-CER,CHIP
2203-005061	C313	C-CER,CHIP
2203-005061	C316	C-CER,CHIP
2203-005061	C367	C-CER,CHIP
2203-005061	C407	C-CER,CHIP
2203-005061	C412	C-CER,CHIP
2203-005061	C422	C-CER,CHIP
2203-005061	C424	C-CER,CHIP
2203-005061	C428	C-CER,CHIP
2203-005288	C120	C-CER,CHIP
2203-005288	C121	C-CER,CHIP
2203-005444	L115	C-CER,CHIP
2203-005482	C146	C-CER,CHIP
2203-005482	C201	C-CER,CHIP
2203-005482	C204	C-CER,CHIP

SEC CODE	Design LOC	Discription
2007-000138	R112	R-CHIP
2007-000138	R322	R-CHIP
2007-000138	R407	R-CHIP
2007-000139	R102	R-CHIP
2007-000139	R103	R-CHIP
2007-000140	R511	R-CHIP
2007-000140	R513	R-CHIP
2007-000140	R514	R-CHIP
2007-000140	R515	R-CHIP
2007-000141	R320	R-CHIP
2007-000141	R516	R-CHIP
2007-000142	R453	R-CHIP
2007-000143	R302	R-CHIP
2007-000143	R303	R-CHIP
2007-000143	R517	R-CHIP
2007-000144	R127	R-CHIP
2007-000148	R108	R-CHIP
2007-000148	R111	R-CHIP
2007-000148	R243	R-CHIP
2007-000148	R380	R-CHIP
2007-000151	R241	R-CHIP
2007-000155	R208	R-CHIP
2007-000156	R521	R-CHIP
2007-000156	R522	R-CHIP
2007-000157	R114	R-CHIP
2007-000157	R203	R-CHIP
2007-000159	R207	R-CHIP
2007-000159	R209	R-CHIP
2007-000159	R424	R-CHIP
2007-000159	R457	R-CHIP
2007-000159	R527	R-CHIP
2007-000159	R528	R-CHIP
2007-000162	R201	R-CHIP
2007-000162	R202	R-CHIP
2007-000162	R242	R-CHIP

SEC CODE	Design LOC	Discription
2203-005482	C205	C-CER,CHIP
2203-005482	C208	C-CER,CHIP
2203-005482	C210	C-CER,CHIP
2203-005482	C308	C-CER,CHIP
2203-005482	C310	C-CER,CHIP
2203-005482	C311	C-CER,CHIP
2203-005482	C314	C-CER,CHIP
2203-005482	C324	C-CER,CHIP
2203-005482	C327	C-CER,CHIP
2203-005482	C338	C-CER,CHIP
2203-005482	C344	C-CER,CHIP
2203-005482	C346	C-CER,CHIP
2203-005482	C361	C-CER,CHIP
2203-005482	C362	C-CER,CHIP
2203-005482	C365	C-CER,CHIP
2203-005482	C368	C-CER,CHIP
2203-005482	C400	C-CER,CHIP
2203-005482	C403	C-CER,CHIP
2203-005482	C516	C-CER,CHIP
2203-005482	C517	C-CER,CHIP
2203-005482	C524	C-CER,CHIP
2203-005482	C544	C-CER,CHIP
2203-005496	C468	C-CER,CHIP
2203-005496	C552	C-CER,CHIP
2203-005496	C553	C-CER,CHIP
2203-005503	C451	C-CER,CHIP
2203-005509	C519	C-CER,CHIP
2203-005552	C111	C-CER,CHIP
2203-005552	C113	C-CER,CHIP
2203-005552	C115	C-CER,CHIP
2203-005552	C119	C-CER,CHIP
2203-005736	C101	C-CER,CHIP
2203-005736	C110	C-CER,CHIP
2203-005736	C112	C-CER,CHIP
2203-006053	C326	C-CER,CHIP

SGH-S410i Main Electrical Parts List

SEC CODE	Design LOC	Discription
2007-000162	R319	R-CHIP
2007-000162	R423	R-CHIP
2007-000162	U518	R-CHIP
2007-000162	U519	R-CHIP
2007-000170	R318	R-CHIP
2007-000170	R377	R-CHIP
2007-000170	R378	R-CHIP
2007-000171	L114	R-CHIP
2007-000171	R128	R-CHIP
2007-000171	R376	R-CHIP
2007-000171	R473	R-CHIP
2007-000171	R529	R-CHIP
2007-000172	R124	R-CHIP
2007-000242	R109	R-CHIP
2007-000242	R326	R-CHIP
2007-000775	R402	R-CHIP
2007-000775	R403	R-CHIP
2007-000982	R381	R-CHIP
2007-001119	R428	R-CHIP
2007-001217	R471	R-CHIP
2007-001217	R472	R-CHIP
2007-001290	R101	R-CHIP
2007-001290	R330	R-CHIP
2007-001290	R331	R-CHIP
2007-001290	R410	R-CHIP
2007-001290	R464	R-CHIP
2007-001291	R104	R-CHIP
2007-001307	R105	R-CHIP
2007-001307	R106	R-CHIP
2007-001307	R304	R-CHIP
2007-001307	R305	R-CHIP
2007-001307	R306	R-CHIP
2007-001307	R307	R-CHIP
2007-001307	R308	R-CHIP
2007-001307	R309	R-CHIP

SEC CODE	Design LOC	Discription
2203-006053	C328	C-CER,CHIP
2203-006053	C406	C-CER,CHIP
2203-006053	C414	C-CER,CHIP
2203-006053	C415	C-CER,CHIP
2203-006053	C416	C-CER,CHIP
2203-006053	C417	C-CER,CHIP
2203-006053	C418	C-CER,CHIP
2203-006053	C419	C-CER,CHIP
2203-006053	C420	C-CER,CHIP
2203-006053	C430	C-CER,CHIP
2203-006053	C432	C-CER,CHIP
2203-006053	C441	C-CER,CHIP
2203-006053	C447	C-CER,CHIP
2203-006053	C463	C-CER,CHIP
2203-006093	C154	C-CER,CHIP
2203-006093	C312	C-CER,CHIP
2203-006093	C315	C-CER,CHIP
2203-006093	C322	C-CER,CHIP
2203-006093	C323	C-CER,CHIP
2203-006093	C332	C-CER,CHIP
2203-006093	C333	C-CER,CHIP
2203-006093	C343	C-CER,CHIP
2203-006093	C355	C-CER,CHIP
2203-006093	C473	C-CER,CHIP
2203-006093	C474	C-CER,CHIP
2203-006093	U408	C-CER,CHIP
2203-006137	C206	C-CER,CHIP
2203-006190	C301	C-CER,CHIP
2203-006190	C302	C-CER,CHIP
2203-006194	C457	C-CER,CHIP
2203-006201	C404	C-CER,CHIP
2203-006257	C438	C-CER,CHIP
2203-006324	C151	C-CER,CHIP
2203-006324	C152	C-CER,CHIP
2203-006324	C341	C-CER,CHIP

SEC CODE	Design LOC	Discription
2007-001307	R310	R-CHIP
2007-001307	R311	R-CHIP
2007-001307	R312	R-CHIP
2007-001307	R313	R-CHIP
2007-001307	R314	R-CHIP
2007-001307	R316	R-CHIP
2007-001307	R356	R-CHIP
2007-001307	R357	R-CHIP
2007-001319	R405	R-CHIP
2007-001323	R123	R-CHIP
2007-001325	R404	R-CHIP
2007-001339	R429	R-CHIP
2007-002797	R110	R-CHIP
2007-003025	R350	R-CHIP
2007-003025	R351	R-CHIP
2007-007142	R352	R-CHIP
2007-007142	R406	R-CHIP
2007-007142	R421	R-CHIP
2007-007142	R422	R-CHIP
2007-007142	R434	R-CHIP
2007-007142	R454	R-CHIP
2007-007308	R413	R-CHIP
2007-007314	R414	R-CHIP
2007-007334	R401	R-CHIP
2007-007488	R436	R-CHIP
2007-007488	R455	R-CHIP
2007-008117	R458	R-CHIP
2007-008263	R430	R-CHIP
2007-008263	R433	R-CHIP
2007-008483	R325	R-CHIP
2007-008542	R205	R-CHIP
2203-000233	C105	C-CER,CHIP
2203-000233	C128	C-CER,CHIP
2203-000233	C129	C-CER,CHIP
2203-000233	C134	C-CER,CHIP

SEC CODE	Design LOC	Discription
2404-001151	C437	C-TA,CHIP
2404-001274	C102	C-TA,CHIP
2404-001306	C520	C-TA,CHIP
2404-001339	C411	C-TA,CHIP
2404-001339	C423	C-TA,CHIP
2404-001348	C439	C-TA,CHIP
2404-001348	C440	C-TA,CHIP
2404-001394	C334	C-TA,CHIP
2404-001394	C549	C-TA,CHIP
2703-001512	L108	INDUCTOR-SMD
2703-001737	L120	INDUCTOR-SMD
2703-001750	L117	INDUCTOR-SMD
2703-001752	L118	INDUCTOR-SMD
2703-001786	L119	INDUCTOR-SMD
2703-002199	C145	INDUCTOR-SMD
2703-002308	L106	INDUCTOR-SMD
2703-002313	L401	INDUCTOR-SMD
2703-002313	L402	INDUCTOR-SMD
2703-002547	L105	INDUCTOR-SMD
2703-002665	L104	INDUCTOR-SMD
2801-004225	OSC300	CRYSTAL-SMD
2801-004373	OSC201	CRYSTAL-SMD
2809-001264	OSC101	OSCILLATOR-VCTCXO
2901-001296	F500	FILTER-EMI SMD
2901-001296	F501	FILTER-EMI SMD
2901-001296	F502	FILTER-EMI SMD
2901-001296	F503	FILTER-EMI SMD
2901-001296	F504	FILTER-EMI SMD
2901-001296	F505	FILTER-EMI SMD
2904-001417	F103	FILTER-SAW
2904-001419	F102	FILTER-SAW
2904-001450	F101	FILTER-SAW
2909-001213	U106	DUPLEXER-ASM
3301-001158	L504	BEAD-SMD
3301-001158	L505	BEAD-SMD

SGH-S410i Main Electrical Parts List

SEC CODE	Design LOC	Discription
2203-000233	C136	C-CER,CHIP
2203-000233	C144	C-CER,CHIP
2203-000233	C421	C-CER,CHIP
2203-000254	C103	C-CER,CHIP
2203-000254	C104	C-CER,CHIP
2203-000254	C106	C-CER,CHIP
2203-000254	C131	C-CER,CHIP
2203-000254	C132	C-CER,CHIP
2203-000254	C133	C-CER,CHIP
2203-000254	C202	C-CER,CHIP
2203-000254	C203	C-CER,CHIP
2203-000254	C207	C-CER,CHIP
2203-000254	C209	C-CER,CHIP
2203-000254	C222	C-CER,CHIP
2203-000254	C223	C-CER,CHIP
2203-000254	C358	C-CER,CHIP
2203-000254	C401	C-CER,CHIP
2203-000254	C402	C-CER,CHIP
2203-000254	C426	C-CER,CHIP

SEC CODE	Design LOC	Discription
3301-001342	F400	BEAD-SMD
3301-001342	L109	BEAD-SMD
3301-001342	U404	BEAD-SMD
3301-001729	L301	BEAD-SMD
3404-001152	SW1	SWITCH-TACT
3404-001152	SW2	SWITCH-TACT
3404-001152	SW3	SWITCH-TACT
3705-001347	CN100	CONNECTOR-COAXIAL
3709-001298	CN401	CONNECTOR-CARD EDGE
3710-002194	CN504	CONNECTOR-SOCKET
3711-005817	CN507	CONNECTOR-HEADER
3722-002082	CN400	JACK-PHONE
4202-001037	ANT101	ANTENNA-CHIP
4302-001184	M400	BATTERY-LI(2ND)
4709-001372	U104	BLUETOOTH MODULE
GH09-00033A	U201	IC MICOM-SGHE720
GH30-00185A	MICROPHONE -ASSY	MICROPHONE-ASSY
GH59-02062A	UNIT-METAL DOME	UNIT-METAL DOME

5. SGH-S410i PCB Diagrams

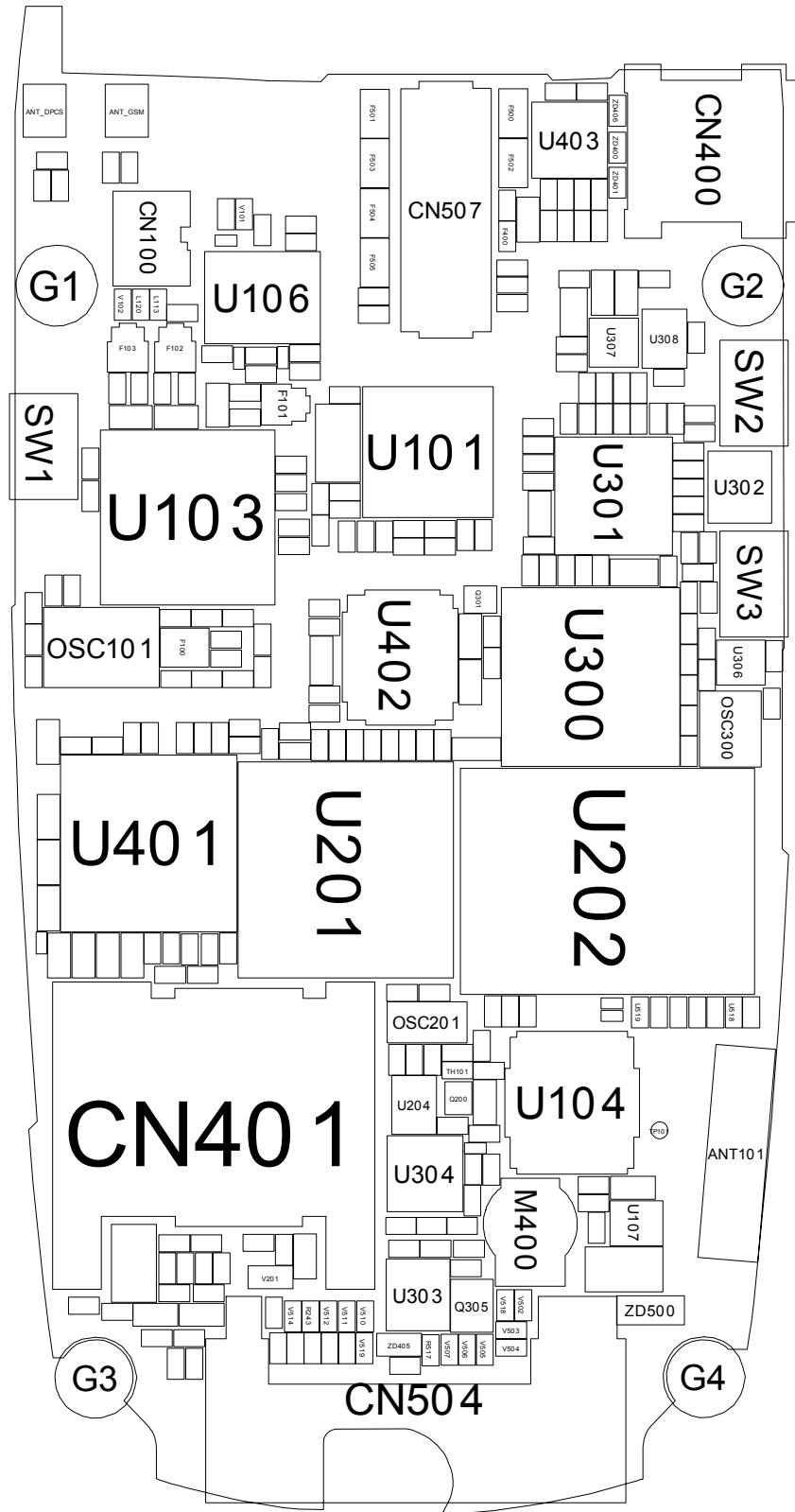

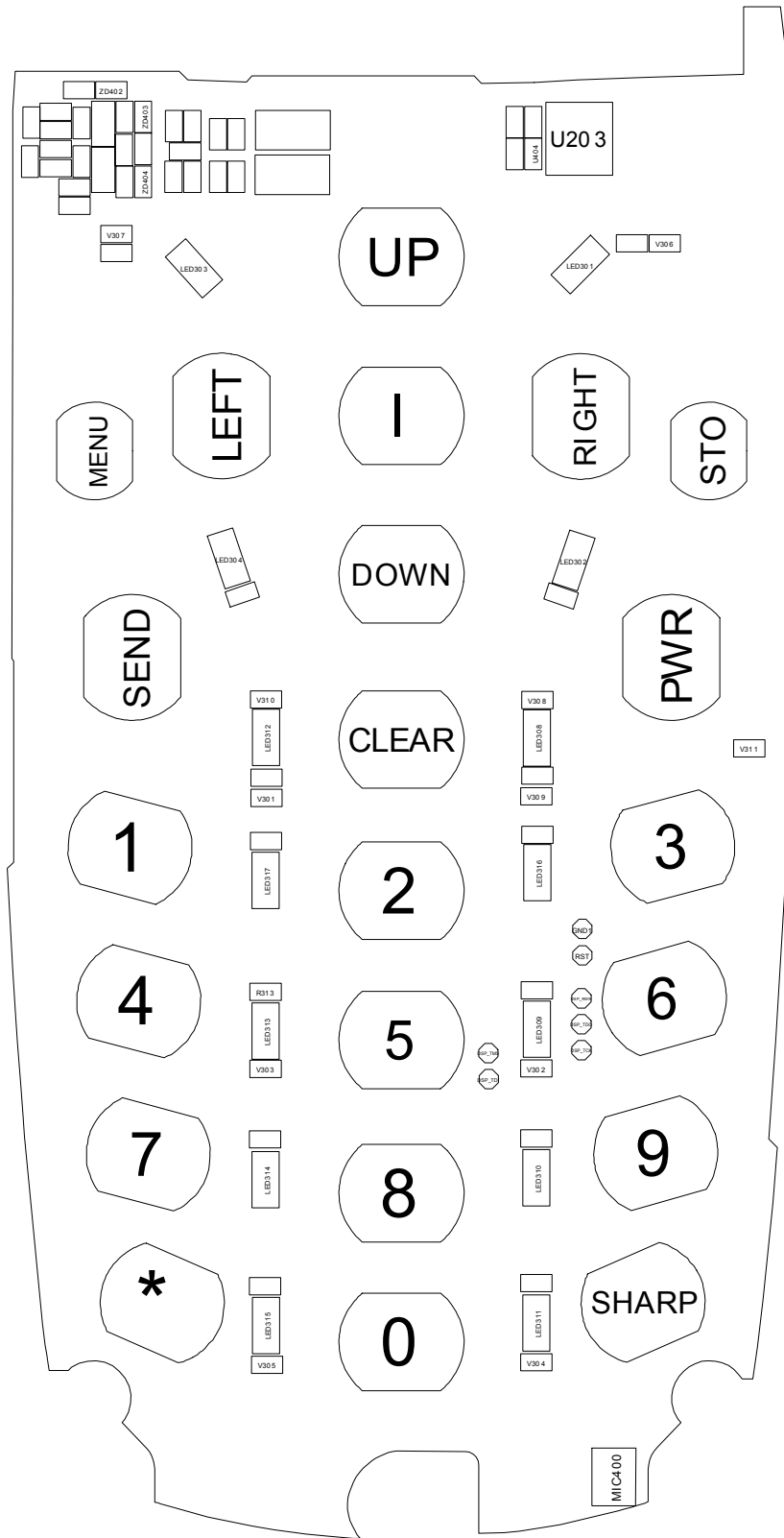

**SAMSUNG
ELECTRONICS**

