

SAMSUNG

GSM TELEPHONE

SGH-S342i

SERVICE *Manual*

GSM TELEPHONE



CONTENTS

1. Specification
2. Flow Chart of Troubleshooting
3. Exploded Views and Parts List
4. Electrical Parts List
5. PCB Diagrams
6. Block Diagrams

1. SGH-S342i Specification

1. GSM General Specification

	GSM900 Phase 1	EGSM 900 Phase 2	DCS1800 Phase 1	PCS1900
Freq. Band[MHz] Uplink/Downlink	890~915 935~960	880~915 925~960	1710~1785 1805~1880	1850~1910 1930~1990
ARFCN range	1~124	0~124 & 975~1023	512~885	512~810
Tx/Rx spacing	45MHz	45MHz	95MHz	80MHz
Mod. Bit rate/ Bit Period	270.833kbps 3.692us	270.833kbps 3.692us	270.833kbps 3.692us	270.833kbps 3.692us
Time Slot Period/Frame Period	576.9us 4.615ms	576.9us 4.615ms	576.9us 4.615ms	576.9us 4.615ms
Modulation	0.3GMSK	0.3GMSK	0.3GMSK	0.3GMSK
MS Power	33dBm~13dBm	33dBm~5dBm	30dBm~0dBm	30dBm~0dBm
Power Class	5pcl ~ 15pcl	5pcl ~ 19pcl	0pcl ~ 15pcl	0pcl ~ 15pcl
Sensitivity	-102dBm	-102dBm	-100dBm	-100dBm
TDMA Mux	8	8	8	8
Cell Radius	35Km	35Km	2Km	-

2. GSM TX power class

TX Power control level	GSM900	TX Power control level	DCS1800	TX Power control level	PCS1900
5	33±2 dBm	0	30±3 dBm	0	30±3 dBm
6	31±2 dBm	1	28±3 dBm	1	28±3 dBm
7	29±2 dBm	2	26±3 dBm	2	26±3 dBm
8	27±2 dBm	3	24±3 dBm	3	24±3 dBm
9	25±2 dBm	4	22±3 dBm	4	22±3 dBm
10	23±2 dBm	5	20±3 dBm	5	20±3 dBm
11	21±2 dBm	6	18±3 dBm	6	18±3 dBm
12	19±2 dBm	7	16±3 dBm	7	16±3 dBm
13	17±2 dBm	8	14±3 dBm	8	14±3 dBm
14	15±2 dBm	9	12±4 dBm	9	12±4 dBm
15	13±2 dBm	10	10±4 dBm	10	10±4 dBm
16	11±3 dBm	11	8±4 dBm	11	8±4 dBm
17	9± 3dBm	12	6±4 dBm	12	6±4 dBm
18	7±3 dBm	13	4±4 dBm	13	4±4 dBm
19	5±3 dBm	14	2±5 dBm	14	2±5 dBm
		15	0±5 dBm	15	0±5 dBm

2. SGH-S342i Flow Chart of Troubleshooting

1. Baseband

1. Power ON

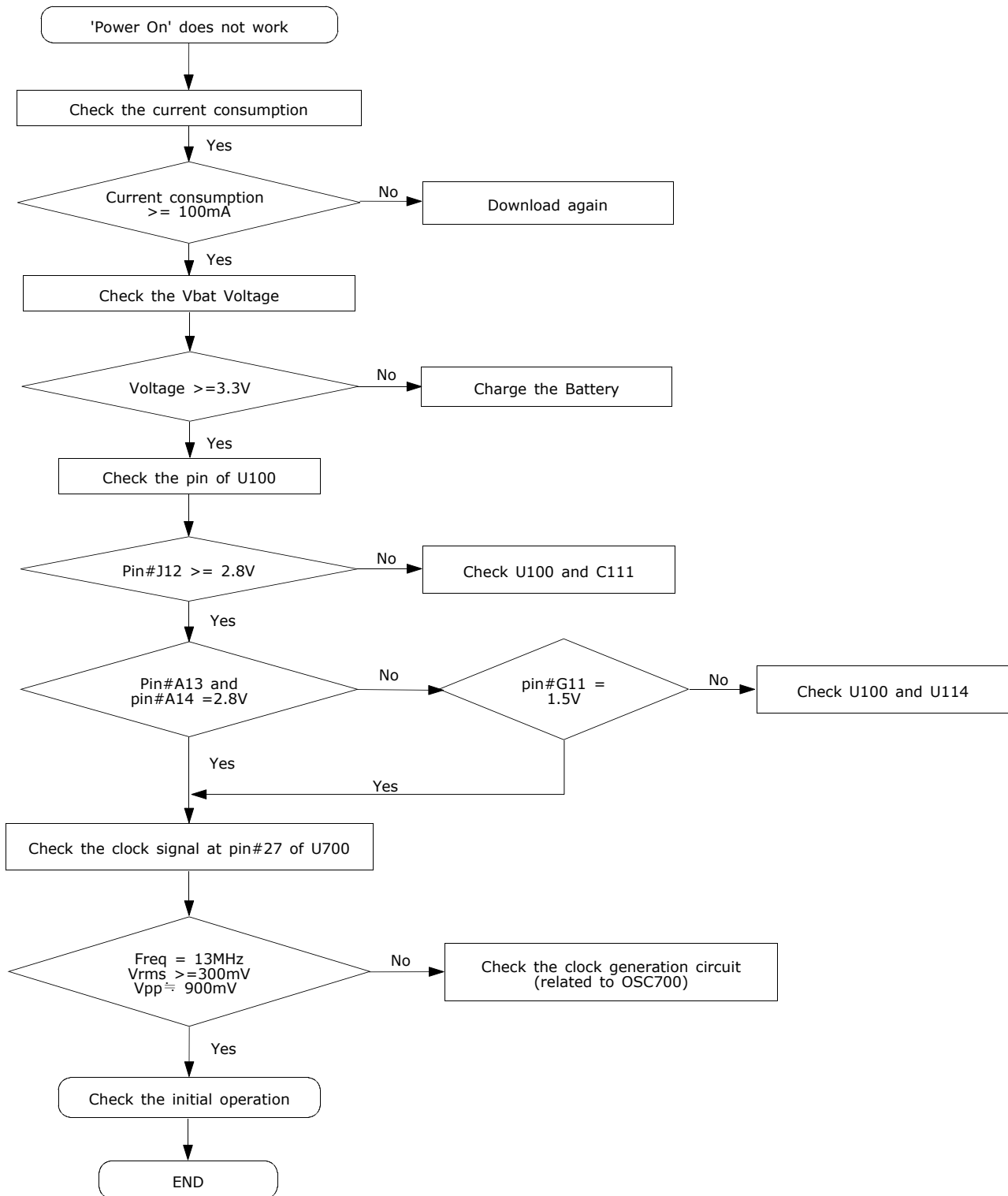

Yes
Is the pin #K9 of U100
"Low → High" ?

No

Check the U100
(if it has some problem, it is to be replaced.)

Yes

There is 32.768kHz wave
forms at the C214 and
C215

No

Check the U200

Yes

Is the pin #A4 of U100
is "High"

No

Check the U700

Yes

The voltage is "High" at
the C113,C110,C119

No

Check the U100

Yes

LCD display is O.K

No

Check the LCD part

Yes

Sound is O.K

No

Check the Audio part

Yes

END

2-2

This Document can not be used without Samsung's authorization

3. Sim Part

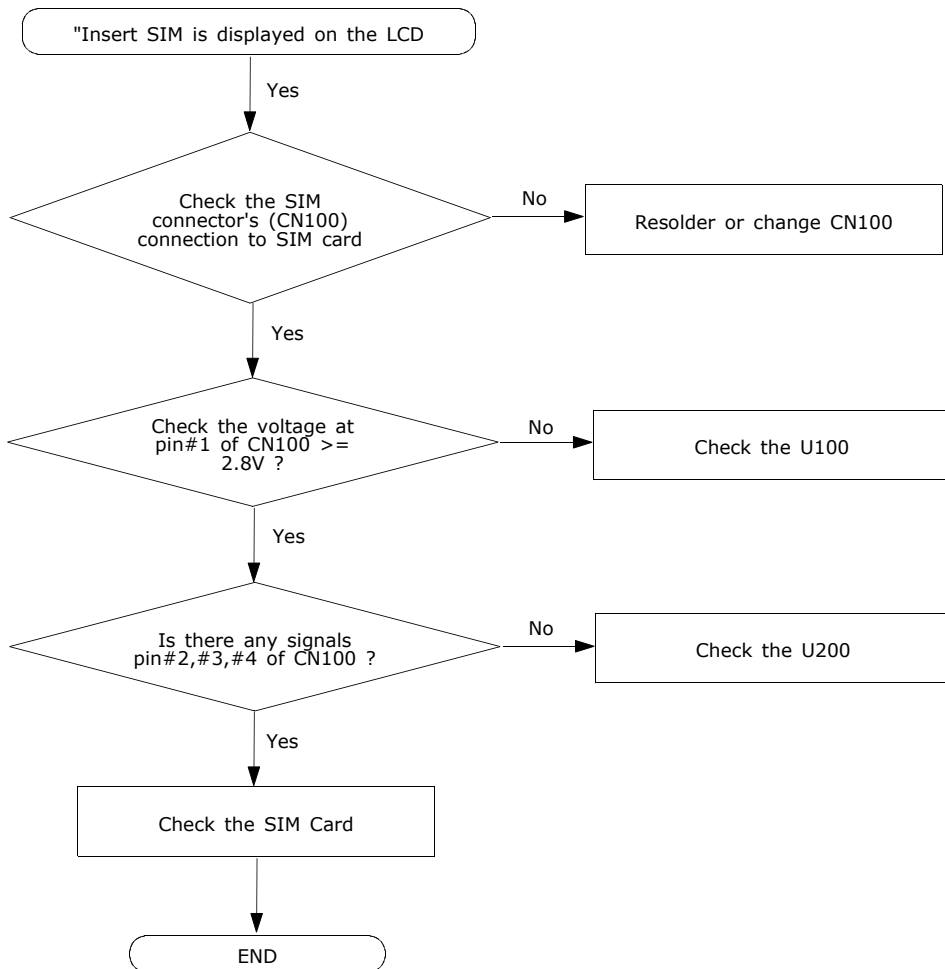

4. Microphone Part

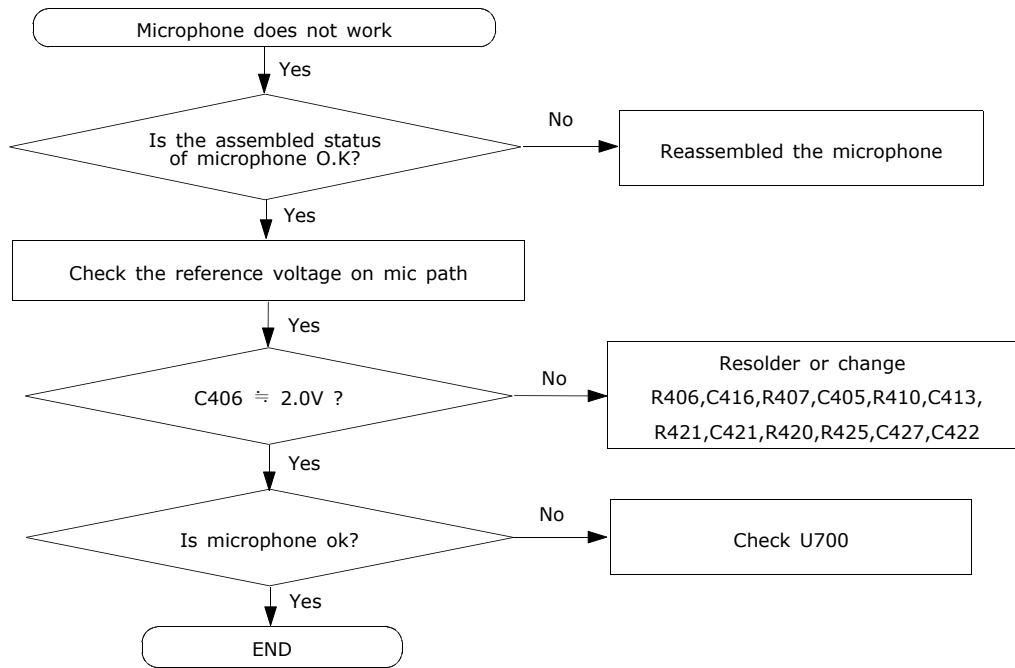

5. Speaker Part

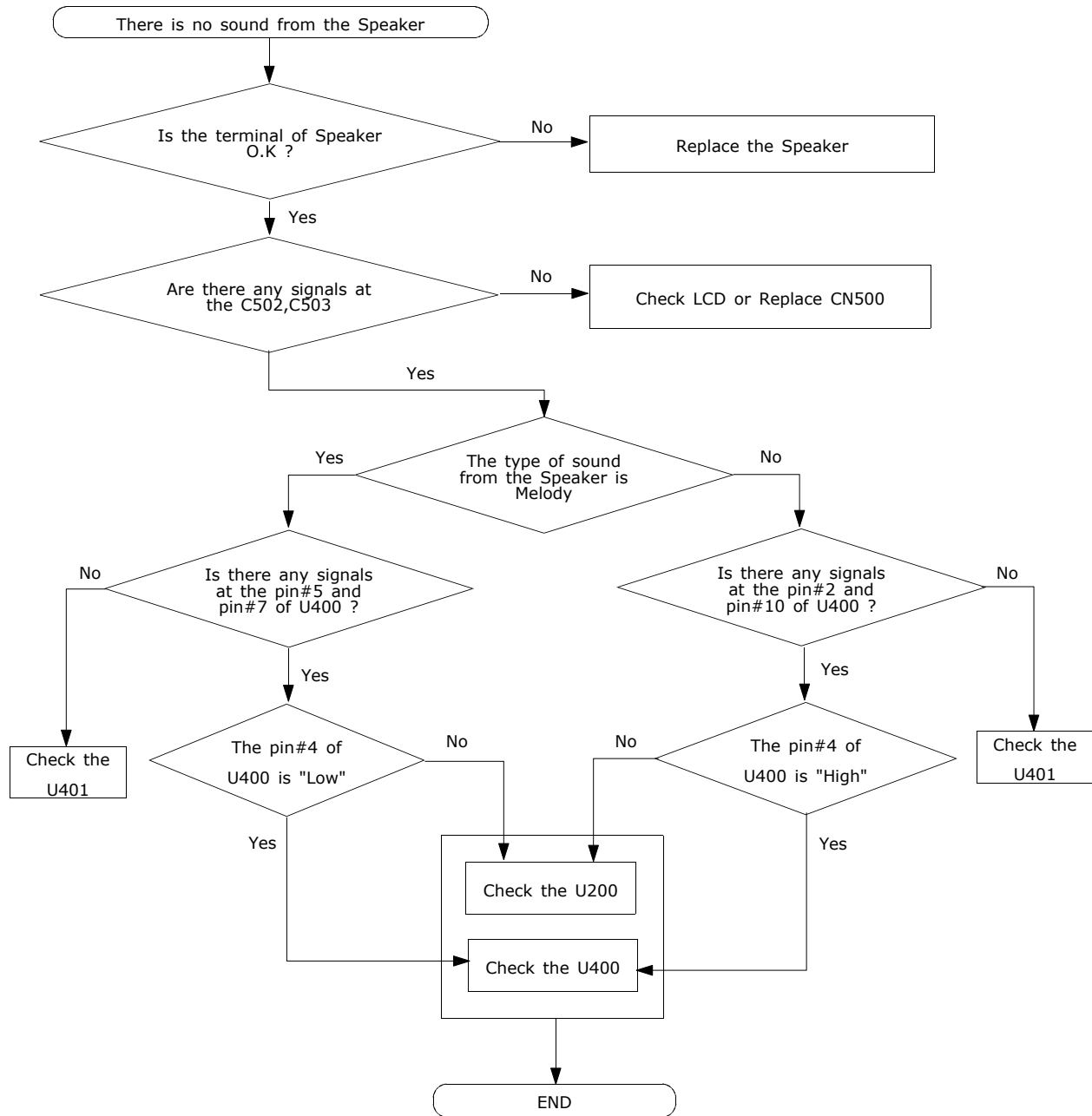

6. Camera Part

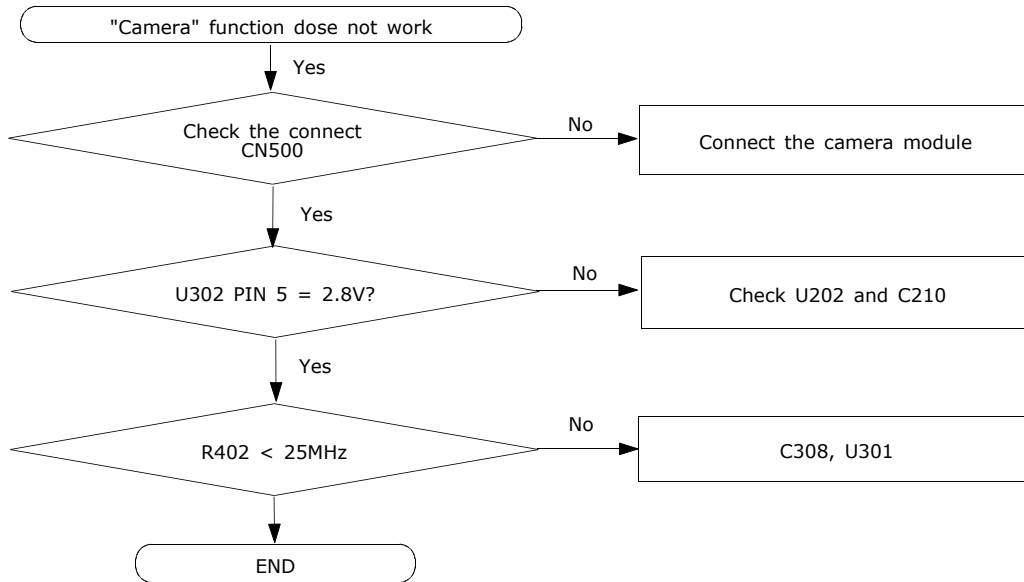

2.RF

1. EGSM RX

CONTINUOUS RX ON
RF INPUT : 62CH
AMP : -50dBm

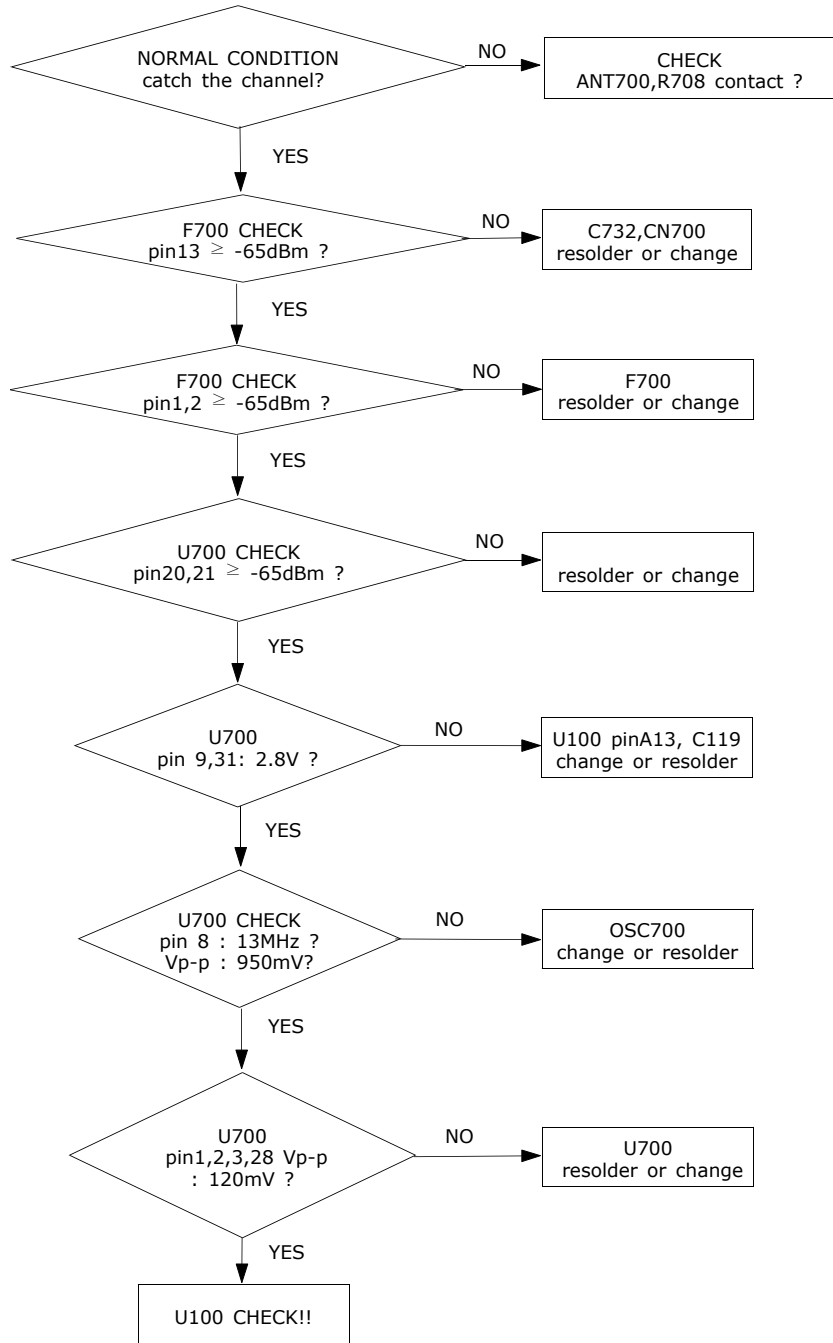

2. DCS RX

CONTINUOUS RX ON
 RF INPUT : 698CH
 AMP : -50dBm

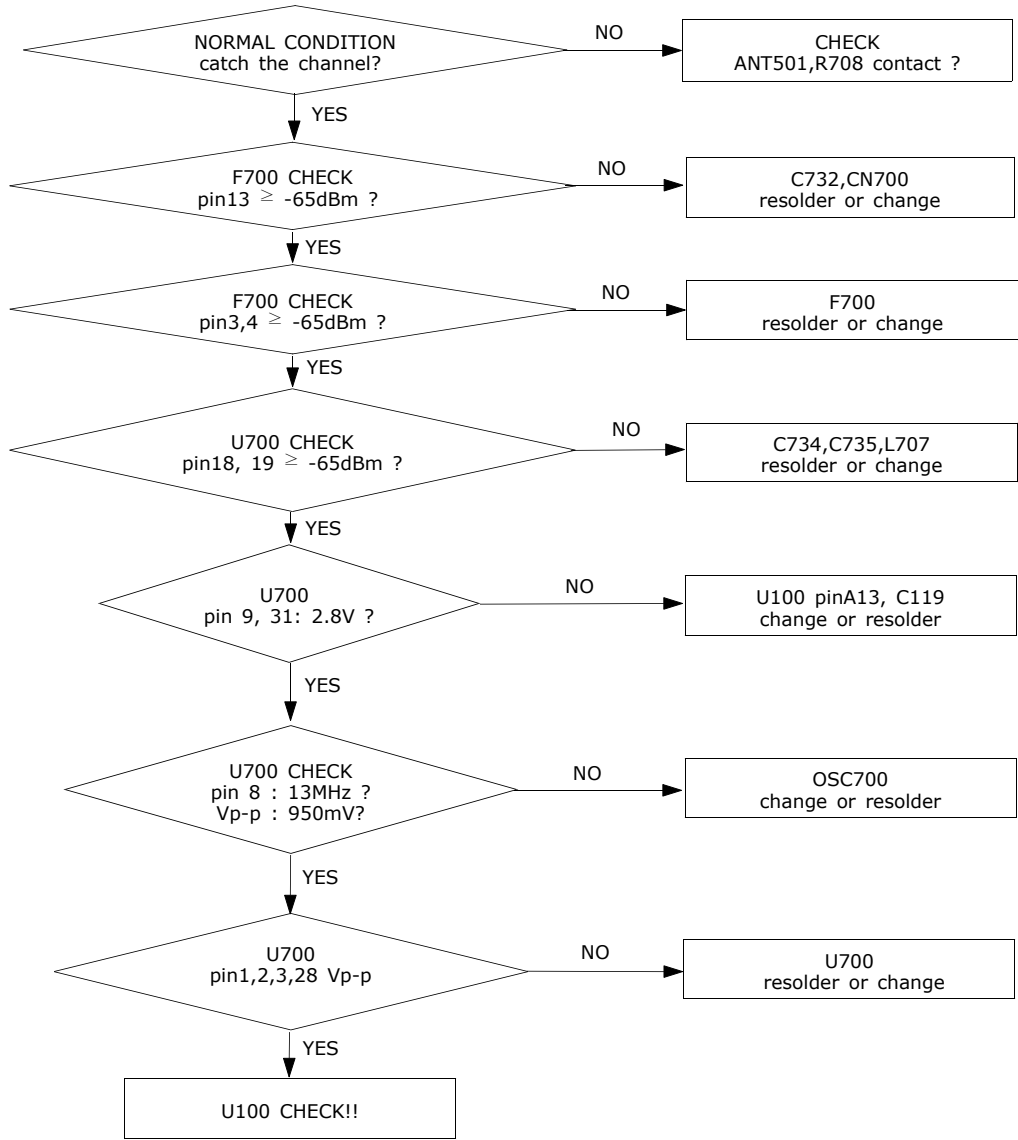

3. PCS RX

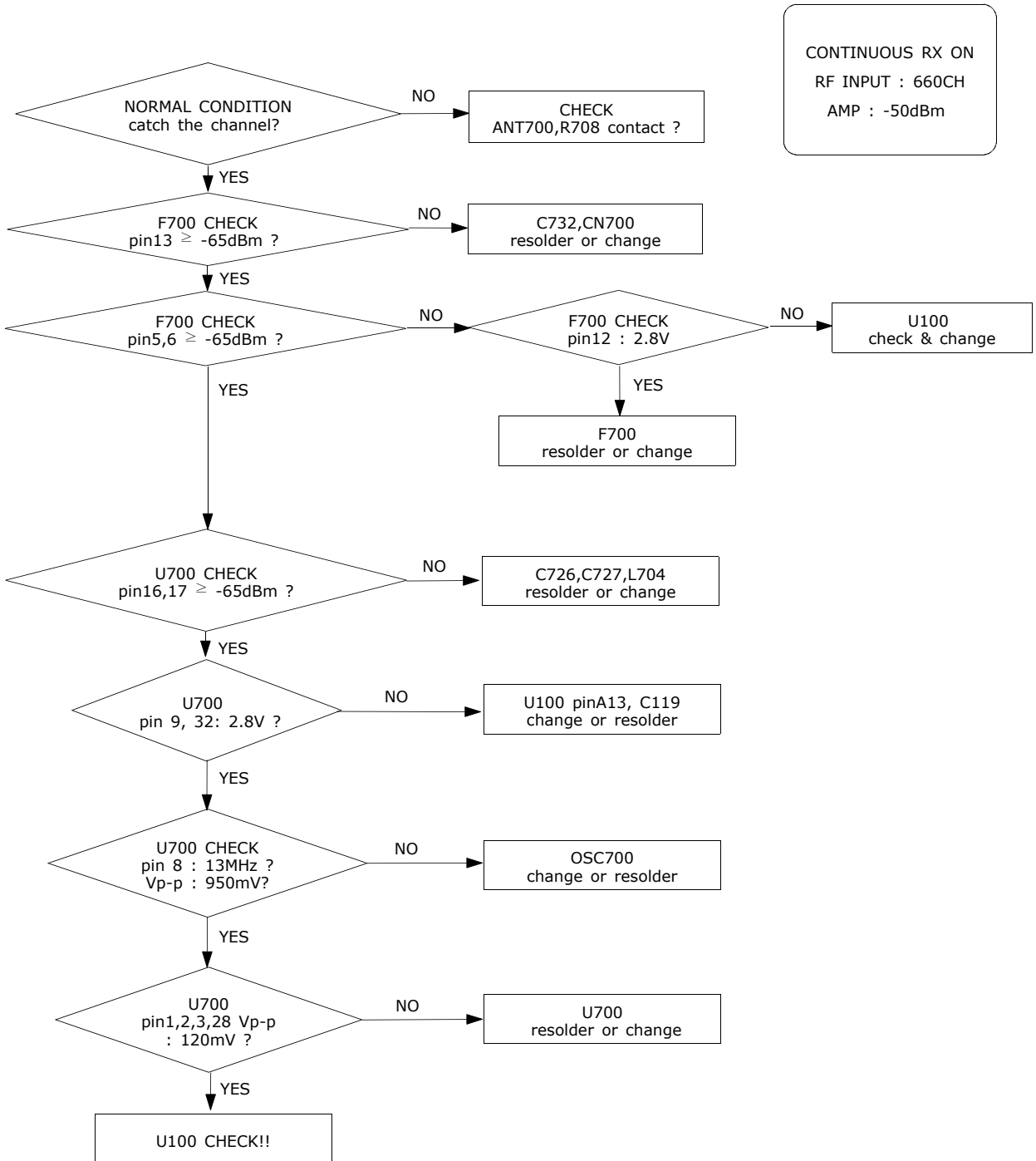

4. EGSM TX

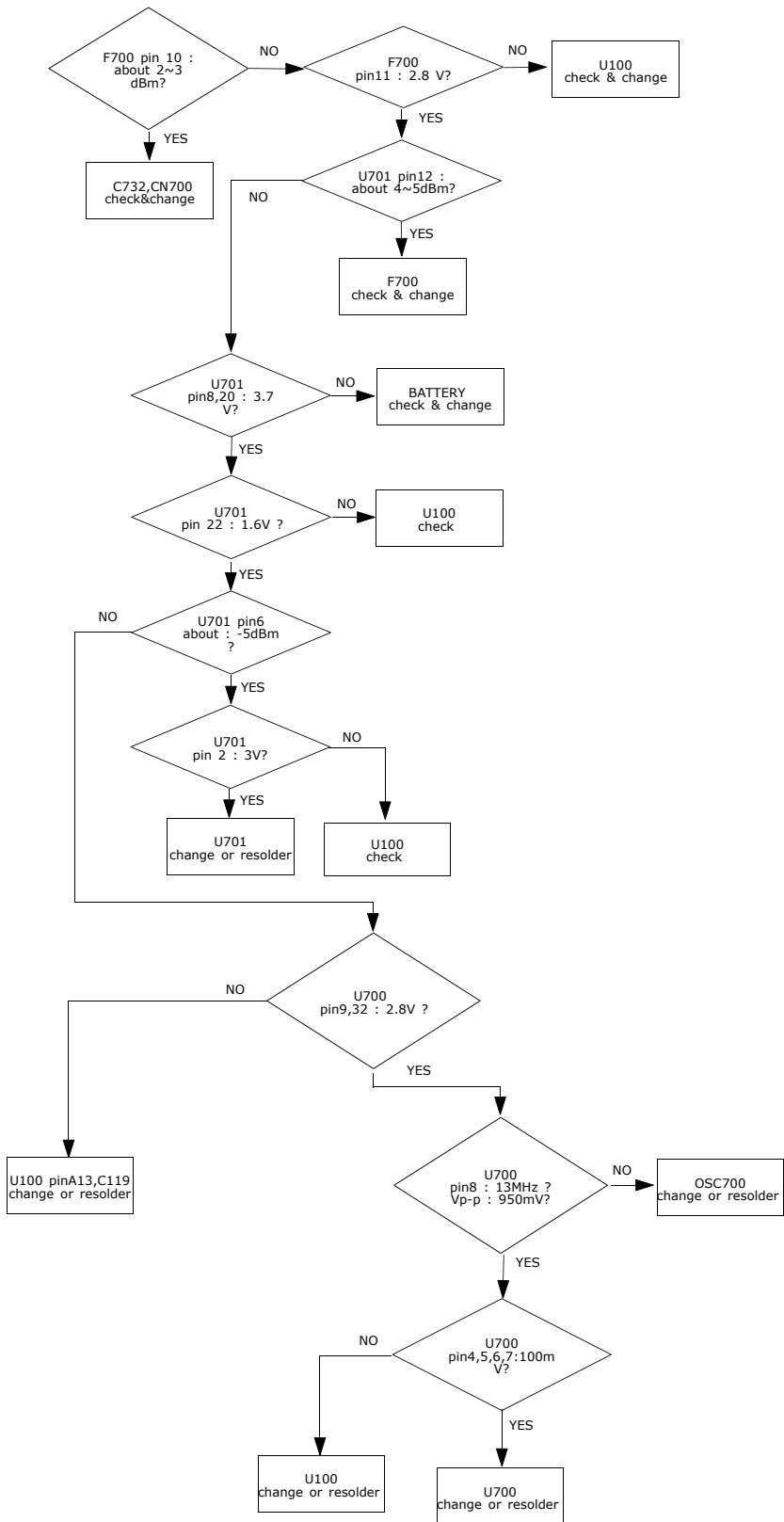

CONTINUOUS TX ON CONDITION
 TX POWER DAC: 600 CODE APPLIED
 CH : 62
 RBW : 100KHz
 VBW : 100KHz
 SPAN : 10MHz
 REF LEV. : 10dBm
 ATT. : 20dB

5. DCS TX

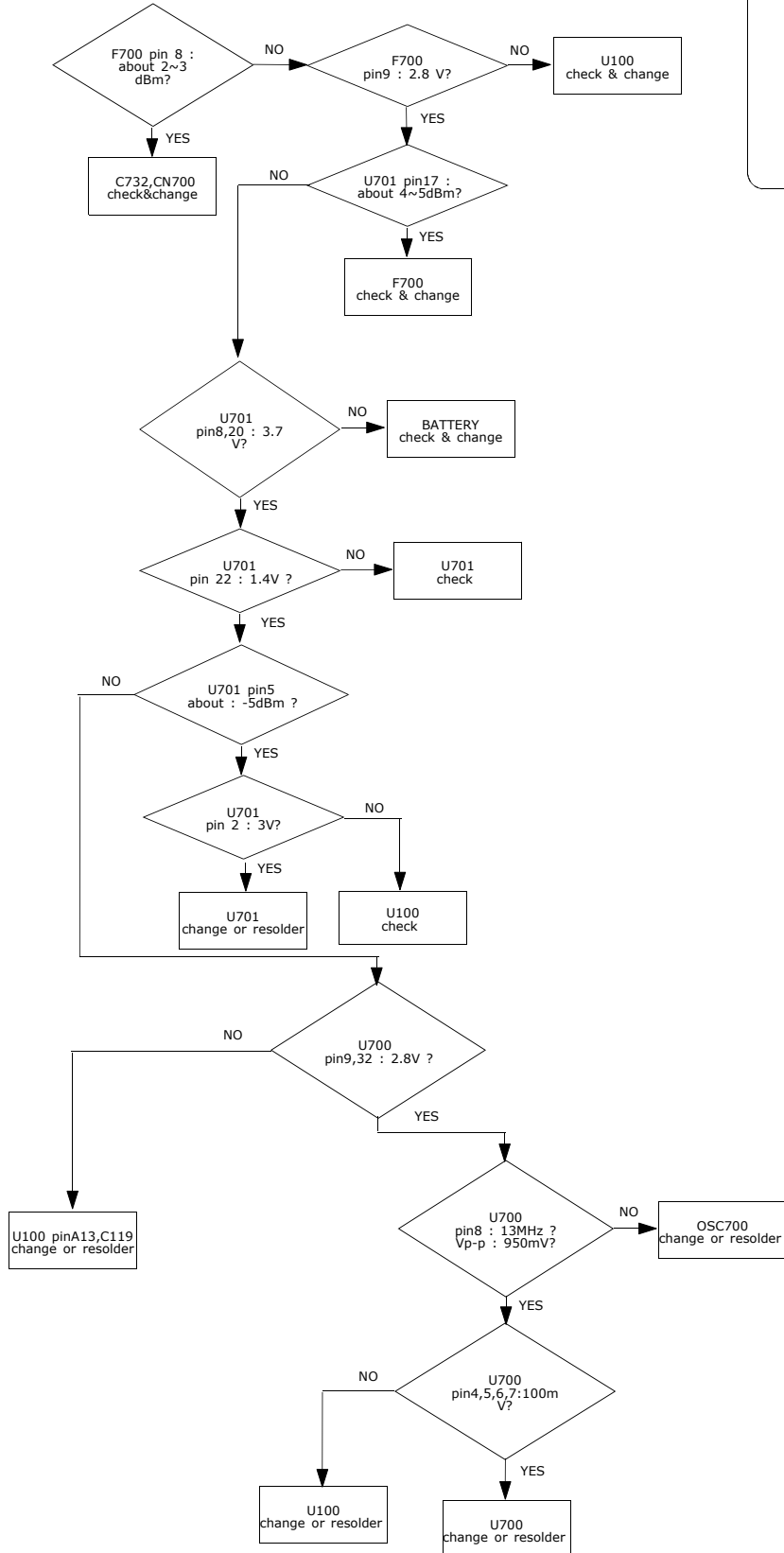

CONTINUOUS TX ON CONDITION
 CH : 698CH(DCS)
 TX POWER CODE: 520 CODE Applied
 RBW : 100KHz
 VBW : 100KHz
 SPAN : 10MHz
 REF LEV. : 10dBm
 ATT. : 20dB

6. PCS TX

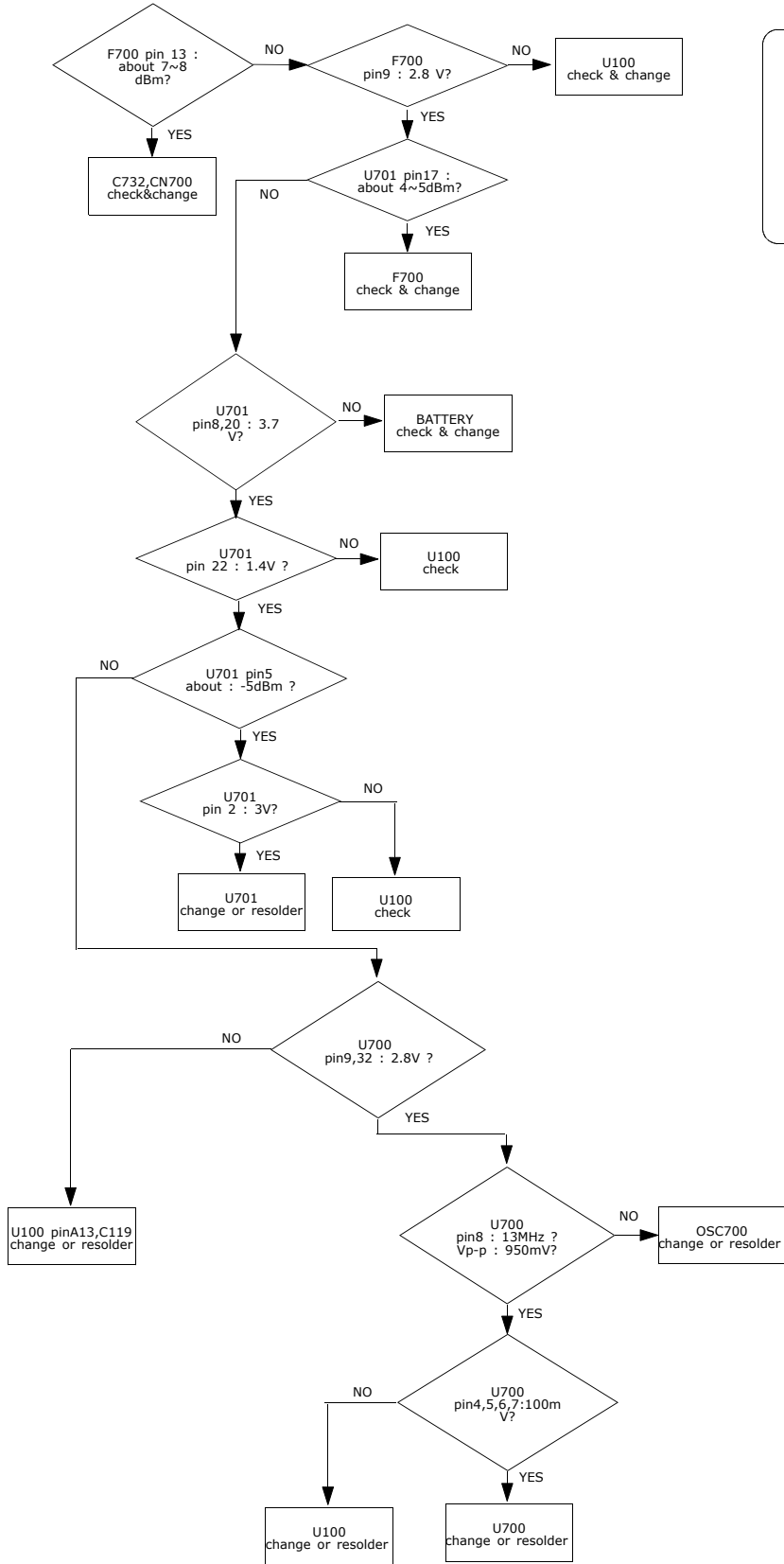

CONTINUOUS TX ON CONDITION
 CH : 660CH(PCS)
 TX POWER CODE: 520 CODE Applied
 RBW : 100KHz
 VBW : 100KHz
 SPAN : 10MHz
 REF LEV. : 10dBm
 ATT. : 20dB

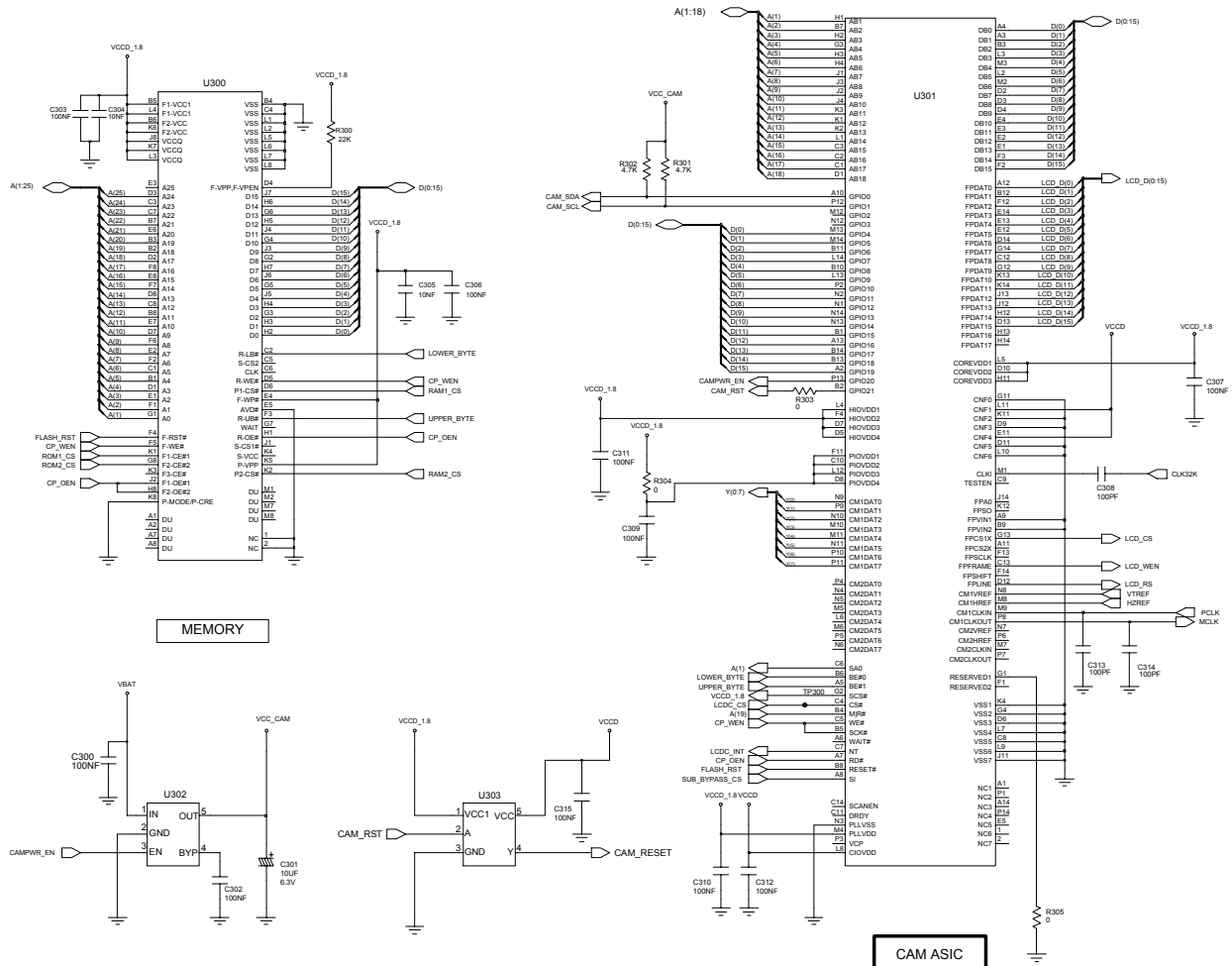

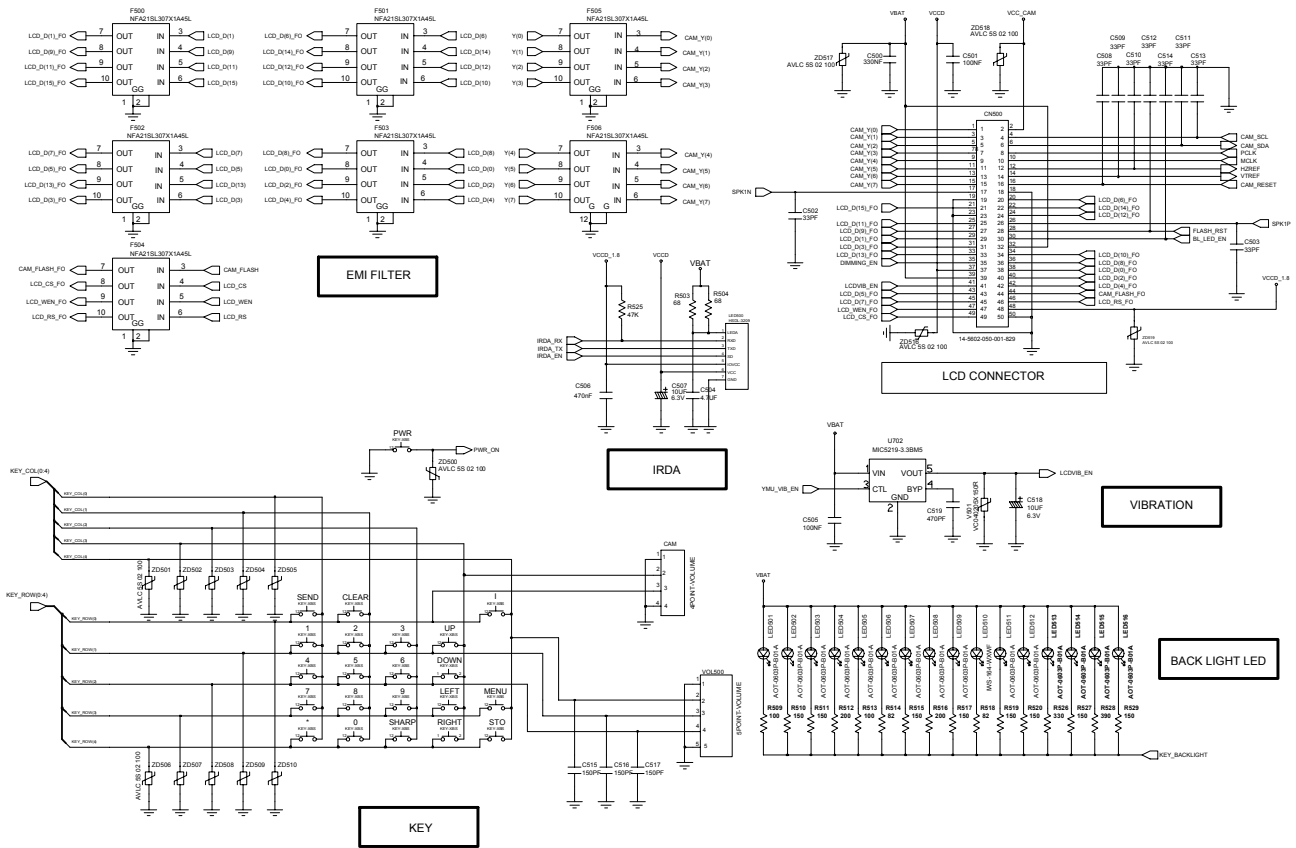

SGH-S342i Flow Chart of Troubleshooting

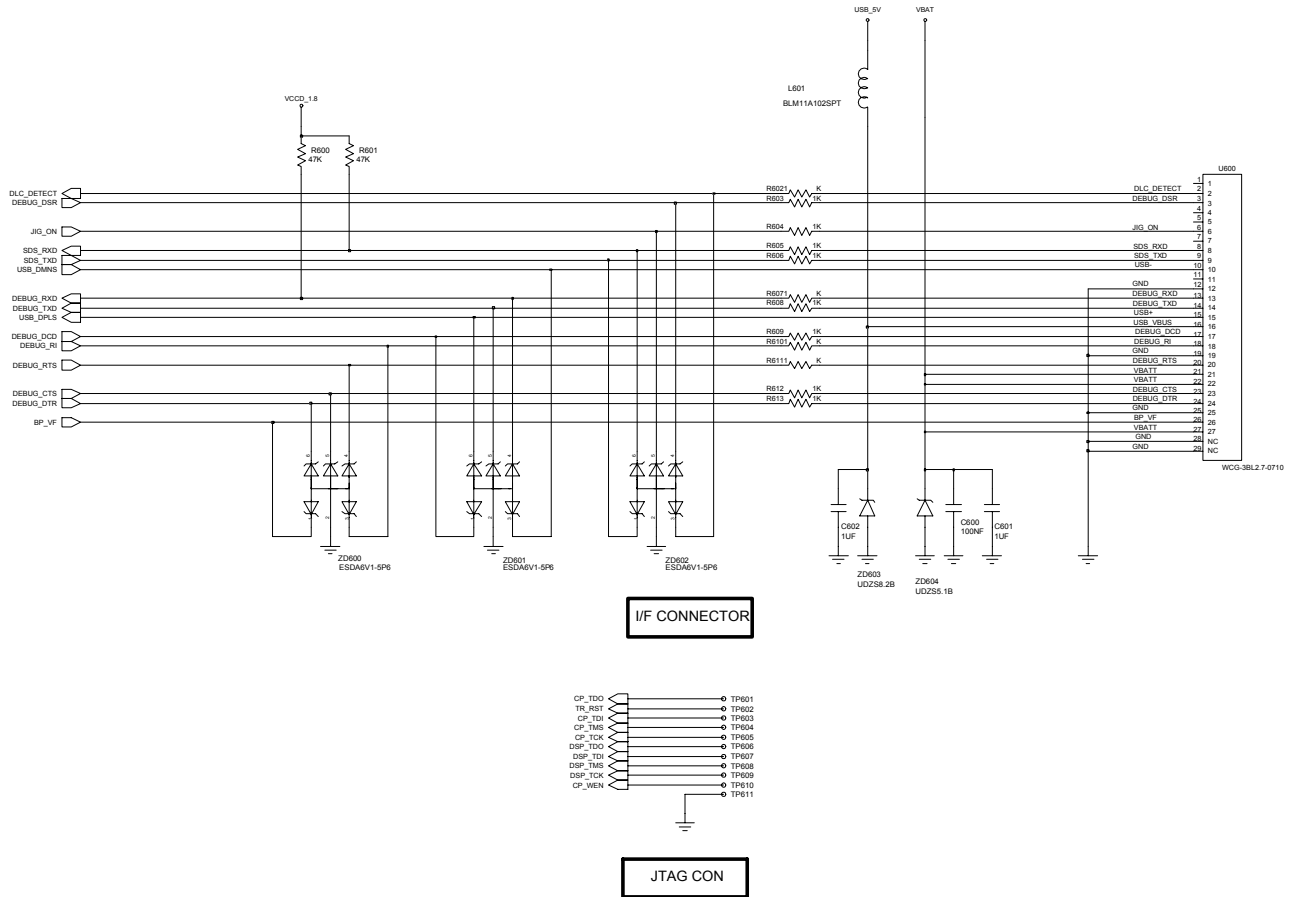

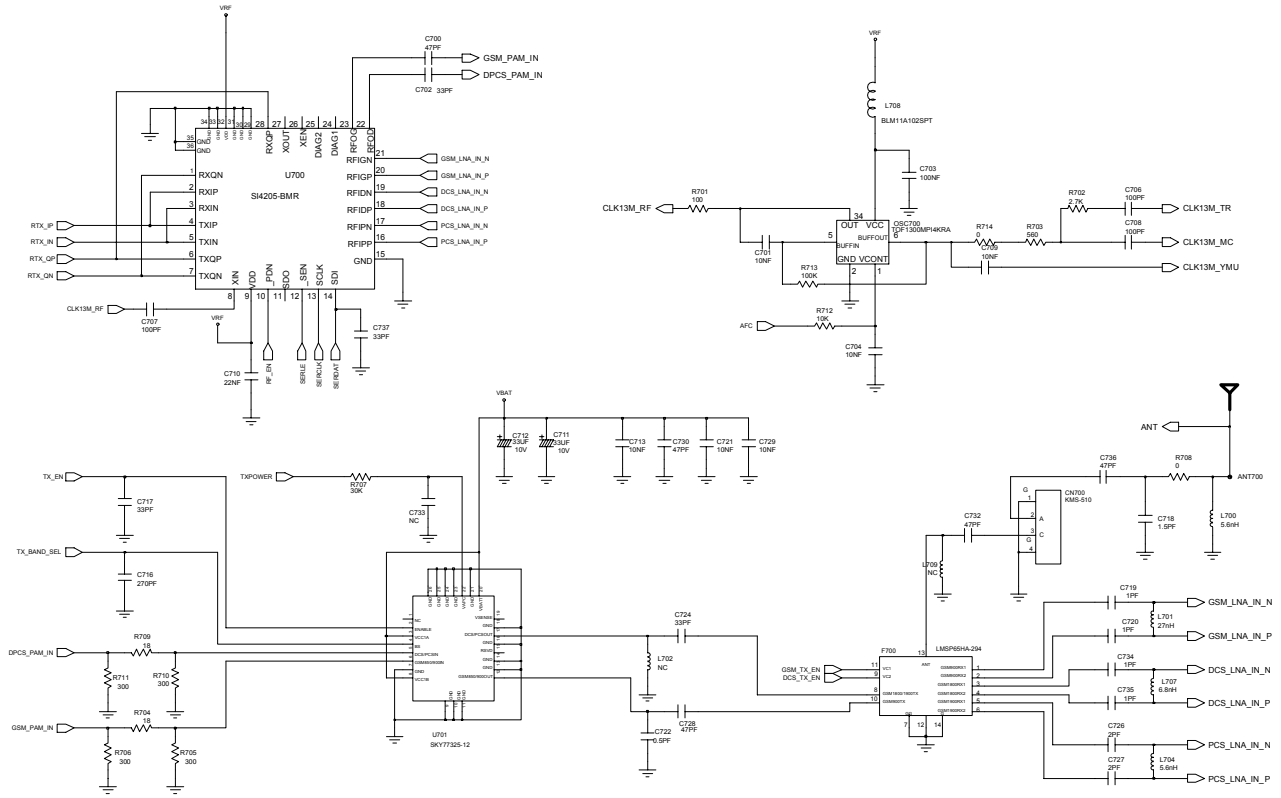

RF PART

3. SGH-S342i Exploded View and Parts List

1. Cellular phone Exploded View

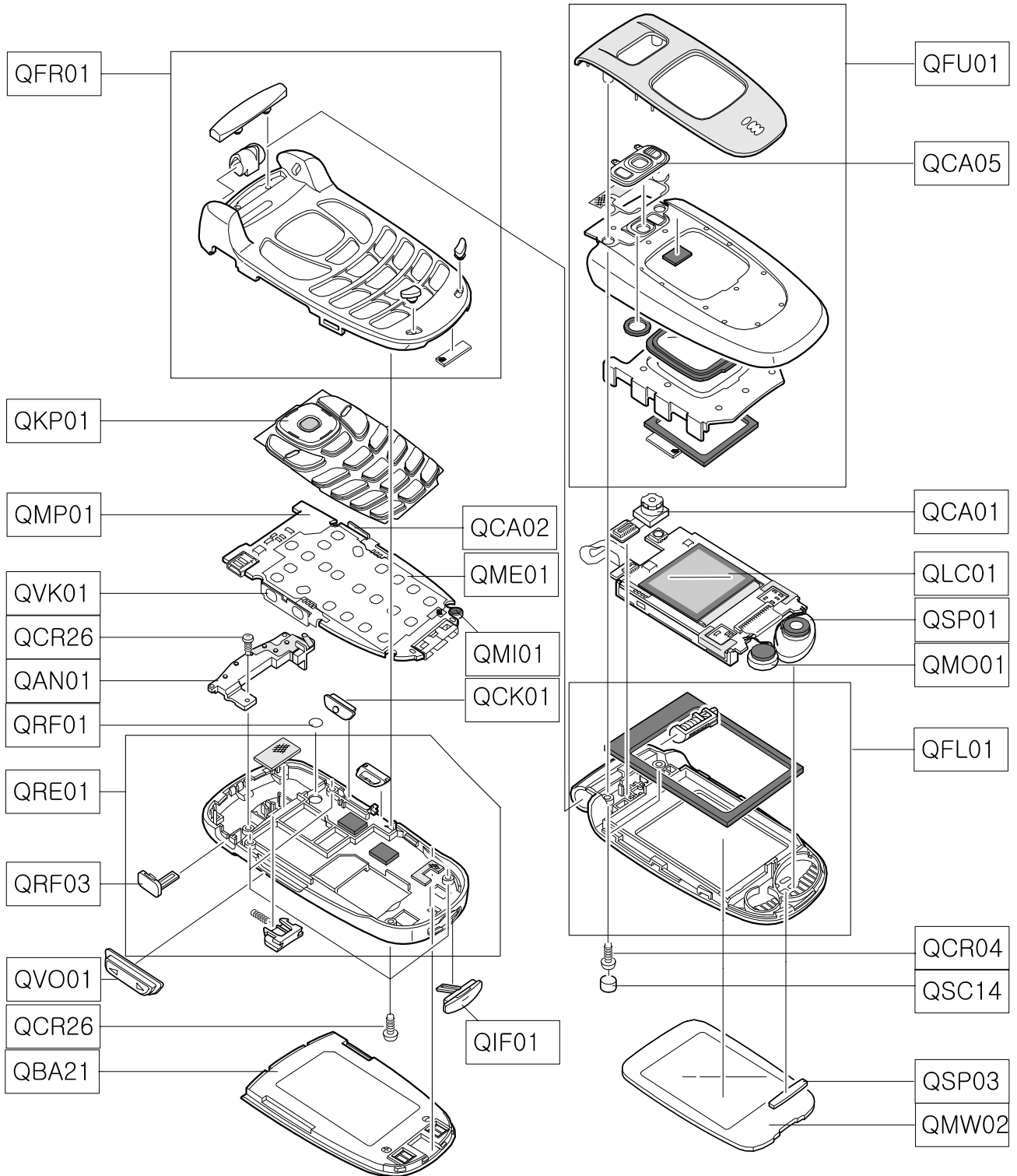

2. Cellular phone Parts list

Location NO.		Description	SEC CODE	Remark
QFU01		MEC-F/UPPER	GH75-05597A	
	QCA05	MEC-CAMERA DECO	GH75-05606A	
QCA01		UNIT-CAMERA	GH59-01722A	
QLC01		LCD-SGHS342I	GH07-00620A	
QSP01		MICRO SPEAKER	3001-001644	
QMO01		MOTOR DC	GH31-00119A	
QFL01		MEC-F/LOWER	GH75-05599A	
QCR04		SCREW-MACHINE	6001-001479	
QSC14		PMO-FOLDER SCREW CAP	GH72-17045A	
QSP03		PMO-SPK DUMMY	GH72-16842A	
QMW02		PMO-MAIN WINDOW	GH72-16844A	
QFR01		MEC-FRONT COVER	GH75-05600A	
QKP01		MEC-KEY PAD	GH75-05602A	
QCA02		UNIT-CAMERA KEY	GH59-01730A	
QMP01		PBA MAIN	GH92-01913A	
QMI01		MICROPHONE-ASSY	GH30-00154A	
QVK01		UNIT-VOLUME KEY	GH59-01729A	
QRF01		MPR-RF SHEET	GH74-11166A	
QME01		UNIT-METAL DOM	GH59-01728A	
QCR26		SCREW-MACHINE	6001-001850	
QAN01		ANTENNA	GH42-00481A	
QCK01		MEC-KEY CAMERA	GH75-05709A	
QRE01		MEC-REAR COVER	GH75-05601A	
	QRF03	PMO-EAR COVER	GH72-16841A	
QVO01		MEC-KEY VOLUME	GH75-05708A	
QIF01		PMO-IF COVER	GH72-17092A	
QBA21		BATTERY-820MAH	GH43-01549A	

3. Test Jig (GH80-03307A)



3-1. RF Test Cable
(GH39-00283A)



3-2. Test Cable
(GH39-00304A)



3-3. Serial Cable

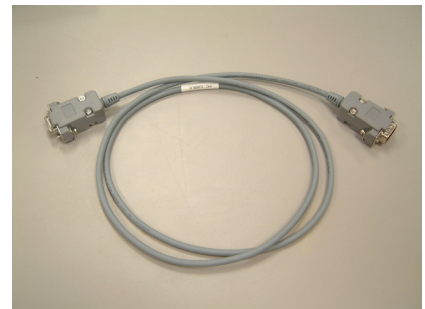

3-4. Power Supply Cable

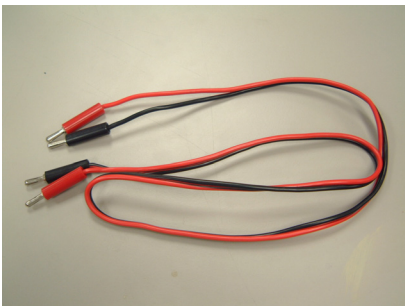

3-5. DATA CABLE
(GH39-00305A)



3-6. TC
(GH44-00701A)

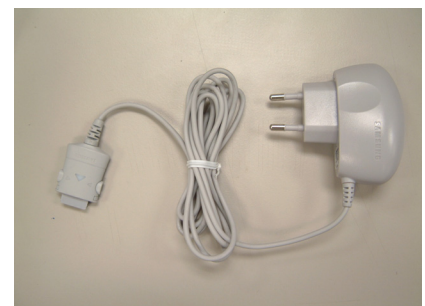

4. SGH-S342i MAIN Electrical Parts List

SEC Code	Design LOC
GH92-01913A	PBA
0403-001387	ZD604
0403-001427	ZD603
0406-001167	ZD400
0406-001167	ZD600
0406-001167	ZD601
0406-001167	ZD602
0504-001140	Q201
0504-001141	Q200
0601-001790	LED501
0601-001790	LED502
0601-001790	LED503
0601-001790	LED504
0601-001790	LED505
0601-001790	LED506
0601-001790	LED507
0601-001790	LED508
0601-001790	LED509
0601-001790	LED511
0601-001790	LED512
0601-001790	LED513
0601-001790	LED514
0601-001790	LED515
0601-001790	LED516
0601-001919	LED510
0604-001291	LED500
0801-002529	U204
0801-002975	U303
0904-001849	U301
1001-001261	U400
1006-001313	U203
1009-001010	U201
1109-001310	U300
1201-002171	U701
1203-001256	U202

SEC Code	Design LOC
2203-000233	C313
2203-000233	C314
2203-000233	C706
2203-000233	C707
2203-000233	C708
2203-000254	C100
2203-000254	C103
2203-000254	C203
2203-000254	C204
2203-000254	C206
2203-000254	C207
2203-000254	C304
2203-000254	C305
2203-000254	C701
2203-000254	C704
2203-000254	C709
2203-000254	C713
2203-000254	C721
2203-000254	C729
2203-000278	C214
2203-000278	C215
2203-000278	C408
2203-000278	C414
2203-000359	C515
2203-000359	C516
2203-000359	C517
2203-000438	C417
2203-000466	C734
2203-000466	C735
2203-000585	C401
2203-000585	C409
2203-000654	C716
2203-000696	C726
2203-000696	C727
2203-000812	C104

SEC Code	Design LOC
1203-001518	U702
1203-002099	U302
1203-003472	U100
1204-002138	U401
1205-002433	U700
1209-001219	U101
1405-001082	V201
1405-001082	V401
1405-001082	V402
1405-001082	V501
1405-001082	ZD401
1405-001108	ZD500
1405-001108	ZD501
1405-001108	ZD502
1405-001108	ZD503
1405-001108	ZD504
1405-001108	ZD505
1405-001108	ZD506
1405-001108	ZD507
1405-001108	ZD508
1405-001108	ZD509
1405-001108	ZD510
1405-001108	ZD516
1405-001108	ZD517
1405-001108	ZD518
1405-001108	ZD519
2007-000138	R103
2007-000138	R509
2007-000138	R513
2007-000138	R701
2007-000139	R419
2007-000140	R216
2007-000140	R602
2007-000140	R603
2007-000140	R604

SEC Code	Design LOC
2203-000812	C107
2203-000812	C108
2203-000812	C406
2203-000812	C425
2203-000812	C502
2203-000812	C503
2203-000812	C702
2203-000812	C717
2203-000812	C724
2203-000812	C737
2203-000836	C416
2203-000836	C419
2203-000940	C421
2203-000940	C423
2203-000940	C519
2203-000995	C211
2203-000995	C700
2203-000995	C728
2203-000995	C730
2203-000995	C732
2203-000995	C736
2203-001101	C212
2203-001383	C722
2203-001385	C718
2203-001405	C208
2203-001405	C403
2203-001405	C429
2203-001598	C106
2203-005061	C101
2203-005061	C102
2203-005061	C105
2203-005061	C115
2203-005061	C117
2203-005061	C300
2203-005061	C302

SEC Code	Design LOC
2007-000140	R605
2007-000140	R606
2007-000140	R607
2007-000140	R608
2007-000140	R609
2007-000140	R610
2007-000140	R611
2007-000140	R612
2007-000140	R613
2007-000142	R702
2007-000143	R301
2007-000143	R302
2007-000148	R203
2007-000148	R204
2007-000148	R205
2007-000148	R712
2007-000153	R300
2007-000156	R707
2007-000157	R202
2007-000157	R208
2007-000157	R211
2007-000157	R525
2007-000157	R600
2007-000157	R601
2007-000162	R100
2007-000162	R201
2007-000162	R206
2007-000162	R207
2007-000162	R213
2007-000162	R215
2007-000162	R422
2007-000162	R713
2007-000164	R402
2007-000170	R104
2007-000171	R217

SEC Code	Design LOC
2203-005061	C309
2203-005061	C311
2203-005061	C400
2203-005061	C402
2203-005061	C410
2203-005061	C418
2203-005061	C435
2203-005061	C703
2203-005288	C719
2203-005288	C720
2203-005482	C200
2203-005482	C201
2203-005482	C202
2203-005482	C205
2203-005482	C209
2203-005482	C213
2203-005482	C216
2203-005482	C303
2203-005482	C306
2203-005482	C307
2203-005482	C310
2203-005482	C312
2203-005482	C315
2203-005482	C501
2203-005482	C505
2203-005482	C600
2203-005503	C428
2203-005509	C500
2203-005682	C508
2203-005682	C509
2203-005682	C510
2203-005682	C511
2203-005682	C512
2203-005682	C513
2203-005682	C514

SEC Code	Design LOC
2007-000171	R220
2007-000171	R222
2007-000171	R303
2007-000171	R304
2007-000171	R305
2007-000171	R411
2007-000171	R412
2007-000171	R708
2007-000171	R714
2007-000242	R210
2007-001217	R514
2007-001217	R518
2007-001288	R704
2007-001288	R709
2007-001290	R212
2007-001290	R214
2007-001295	R400
2007-001295	R401
2007-001295	R440
2007-001295	R441
2007-001301	R503
2007-001301	R504
2007-001306	R510
2007-001306	R511
2007-001306	R515
2007-001306	R517
2007-001306	R519
2007-001306	R520
2007-001306	R527
2007-001306	R529
2007-001308	R512
2007-001308	R516
2007-001313	R526
2007-001319	R101
2007-001325	R413

SEC Code	Design LOC
2203-006093	C118
2203-006093	C405
2203-006093	C413
2203-006093	C422
2203-006093	C427
2203-006093	C601
2203-006093	C602
2203-006108	C111
2203-006108	C112
2203-006108	C113
2203-006108	C114
2203-006108	C119
2203-006137	C710
2203-006208	C504
2203-006257	C506
2404-001225	C110
2404-001225	C120
2404-001225	C210
2404-001225	C301
2404-001225	C404
2404-001225	C415
2404-001225	C507
2404-001225	C518
2404-001268	C411
2404-001268	C412
2404-001274	C711
2404-001274	C712
2404-001305	C420
2703-001907	L701
2703-002547	L707
2703-002586	L700
2703-002665	L704
2801-003747	OSC200
2809-001284	OSC700
2901-001286	F500

SEC Code	Design LOC
2007-001333	R404
2007-001339	R423
2007-002797	R703
2007-007008	R705
2007-007008	R706
2007-007008	R710
2007-007008	R711
2007-007021	R406
2007-007021	R414
2007-007095	R528
2007-007101	R403
2007-007134	R421
2007-007134	R427
2007-007142	R407
2007-007142	R410
2007-007142	R420
2007-007142	R425
2007-007317	R405
2007-007317	R417
2007-007317	R418
2007-007317	R424
2007-007491	R102
2203-000233	C109
2203-000233	C308

SEC Code	Design LOC
2901-001286	F501
2901-001286	F502
2901-001286	F503
2901-001286	F504
2901-001286	F505
2901-001286	F506
2909-001249	F700
3301-001105	L601
3301-001105	L708
3301-001362	L200
3301-001438	L400
3301-001438	L401
3705-001355	CN700
3709-001298	CN100
3710-002189	U600
3711-005159	CN500
3722-002181	CN400
4302-001158	BAT1
GH09-00031A	U200
GH30-00154A	MICROPHONE ASSY
GH59-01728A	METAL DOME
GH59-01729A	VOLUME KEY
GH59-01730A	CAMERA KEY

5. SGH-S342i PCB Diagrams

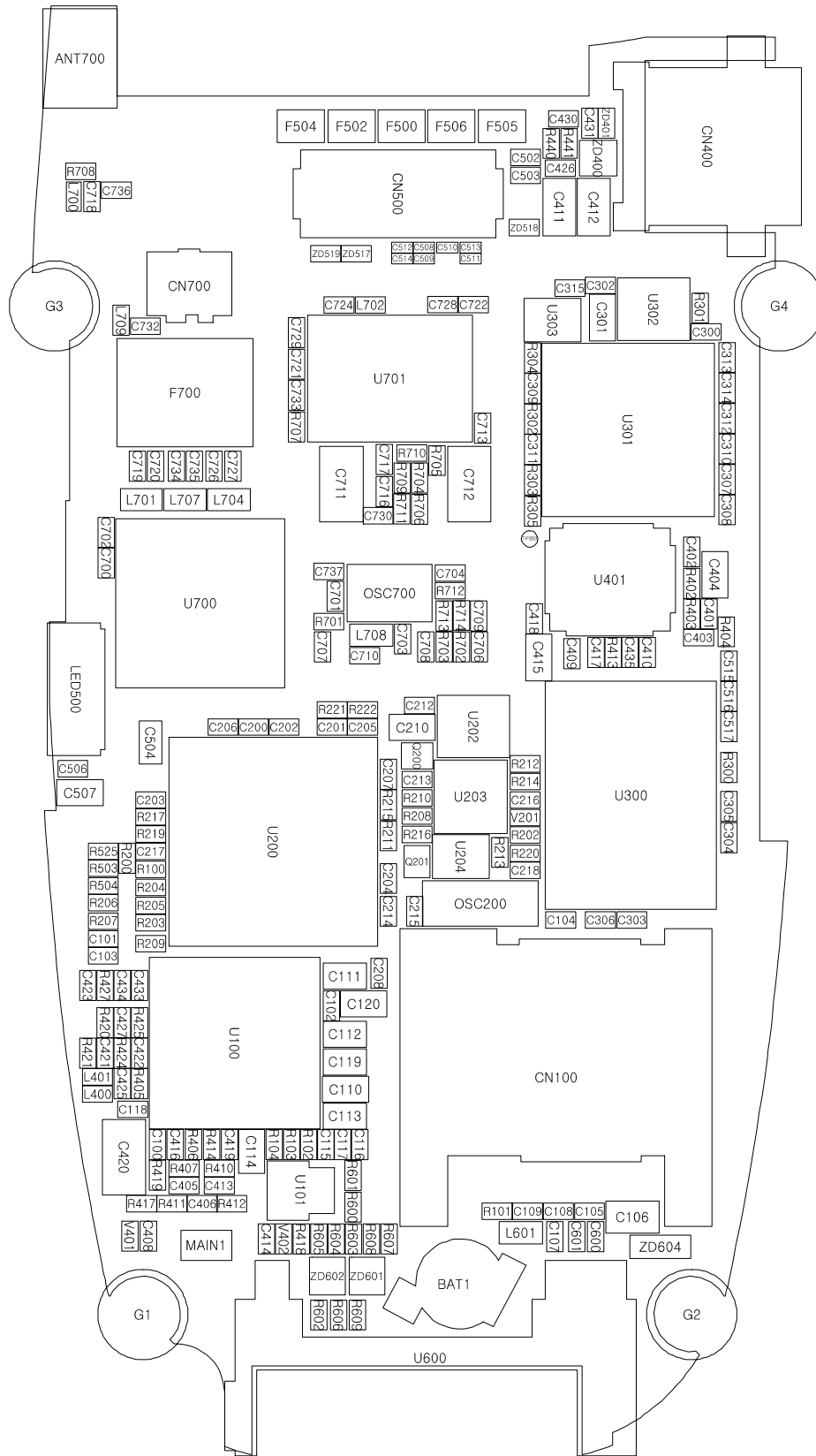

6. SGH-S342i Block Diagrams

1. RF Solution Block Diagram

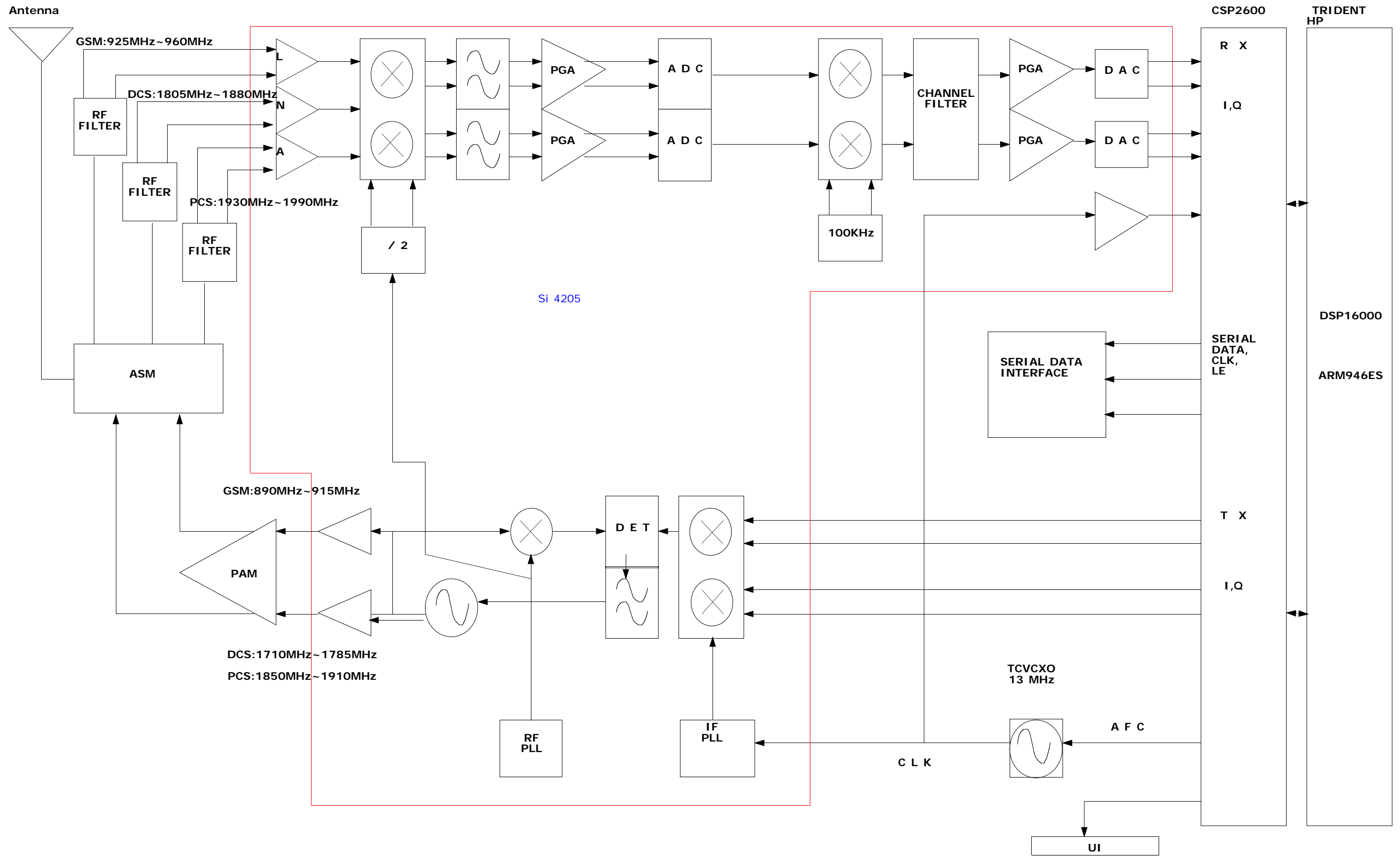

2. Base Band Solution Block Diagram

