

10. Flow Chart of Troubleshooting

10-1. Power On

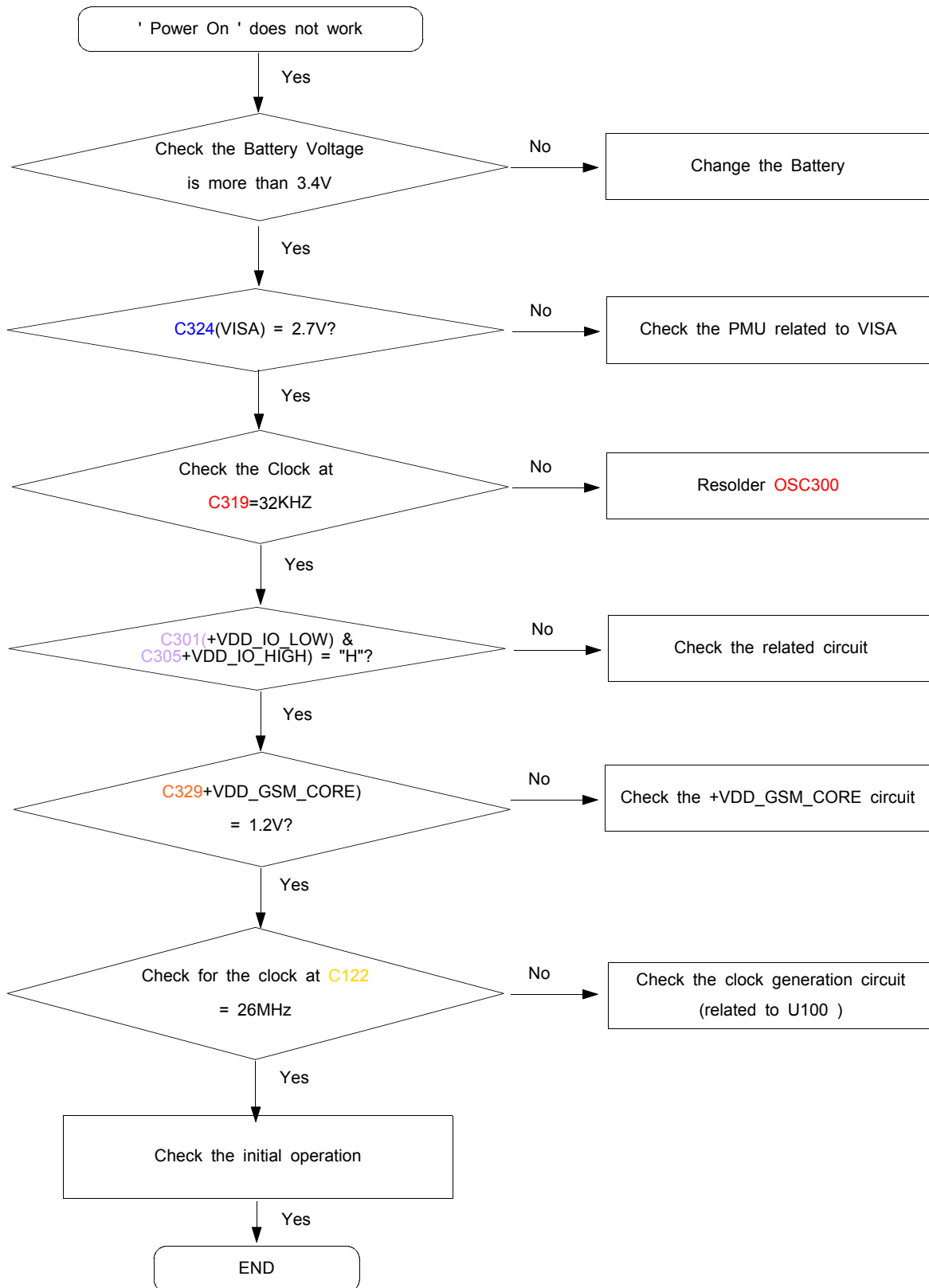

Flow Chart of Troubleshooting

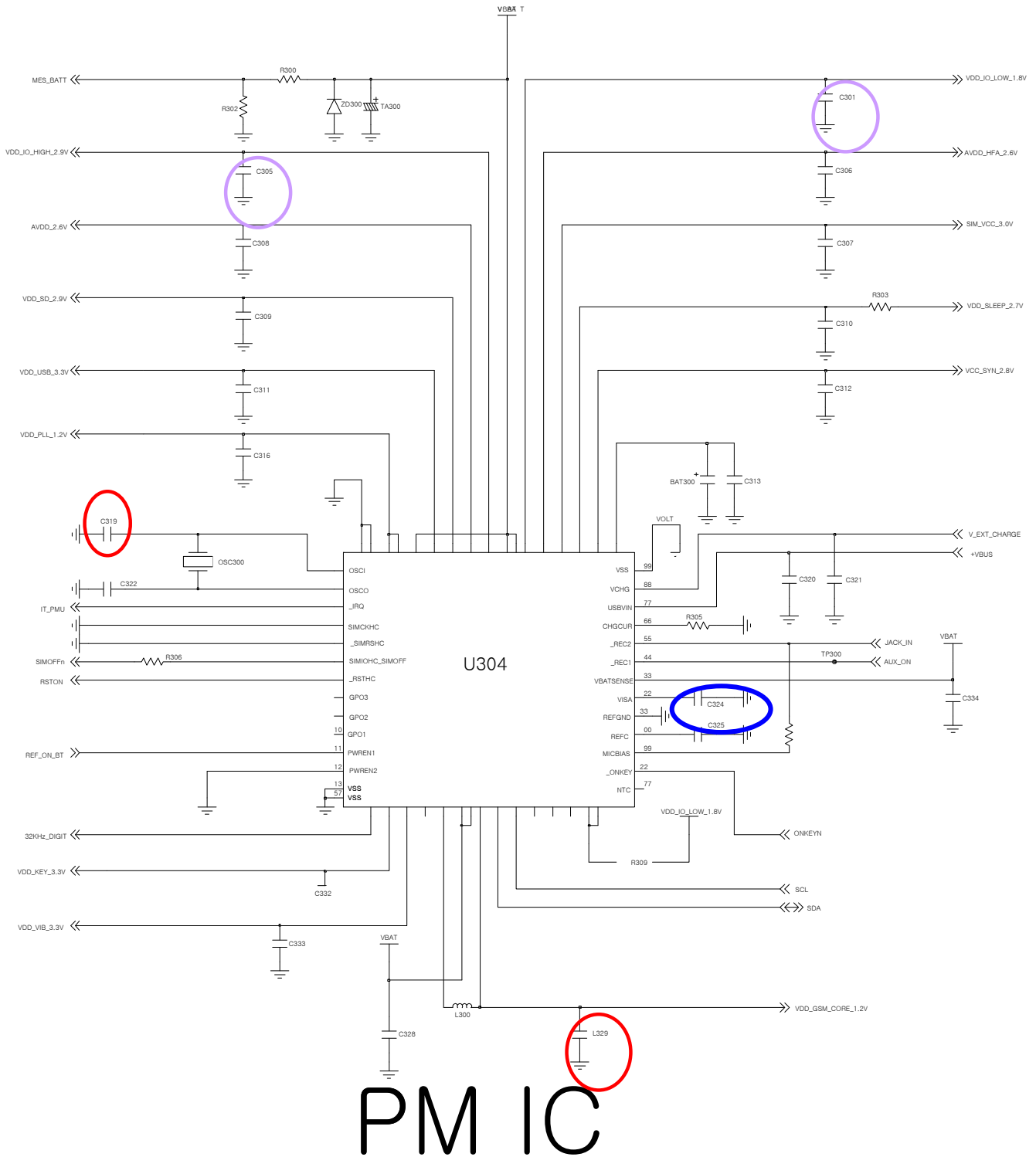

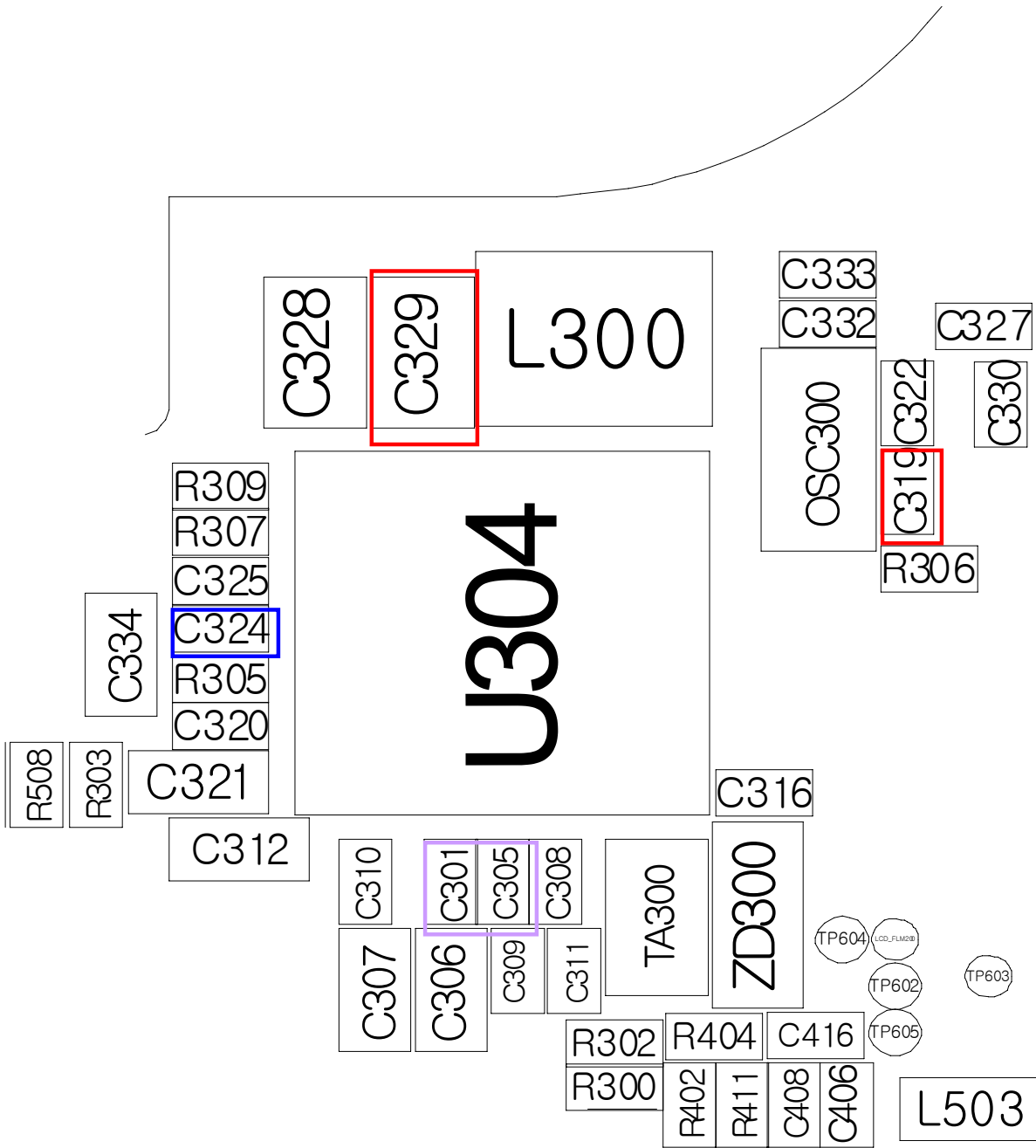

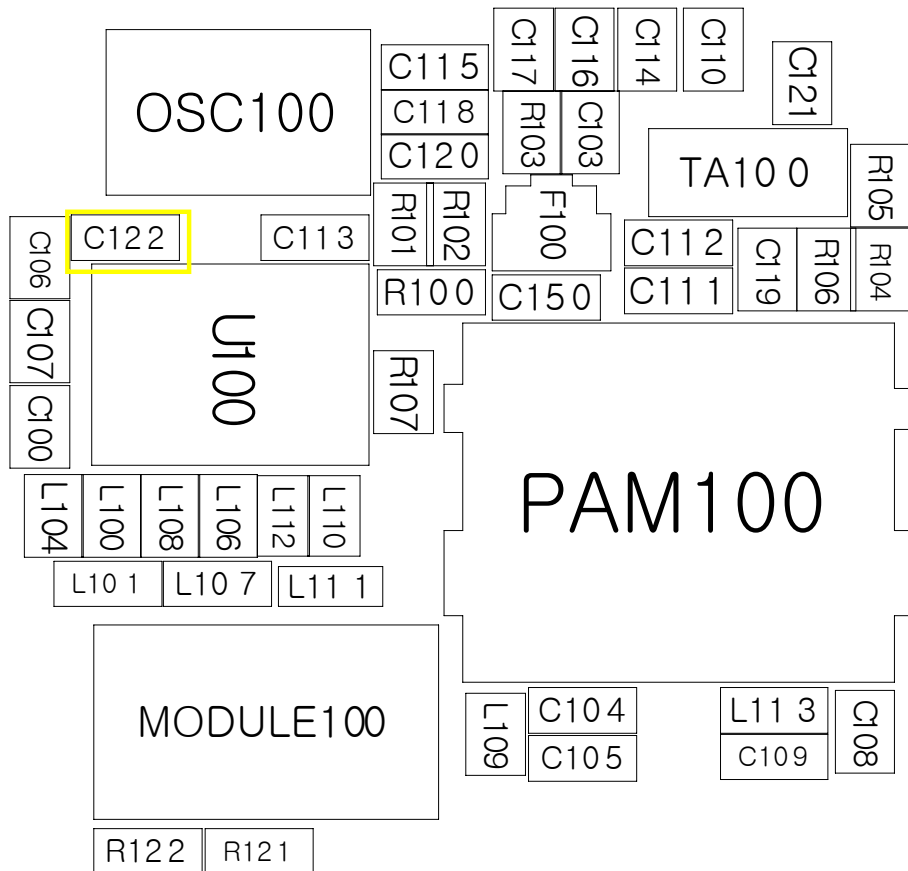
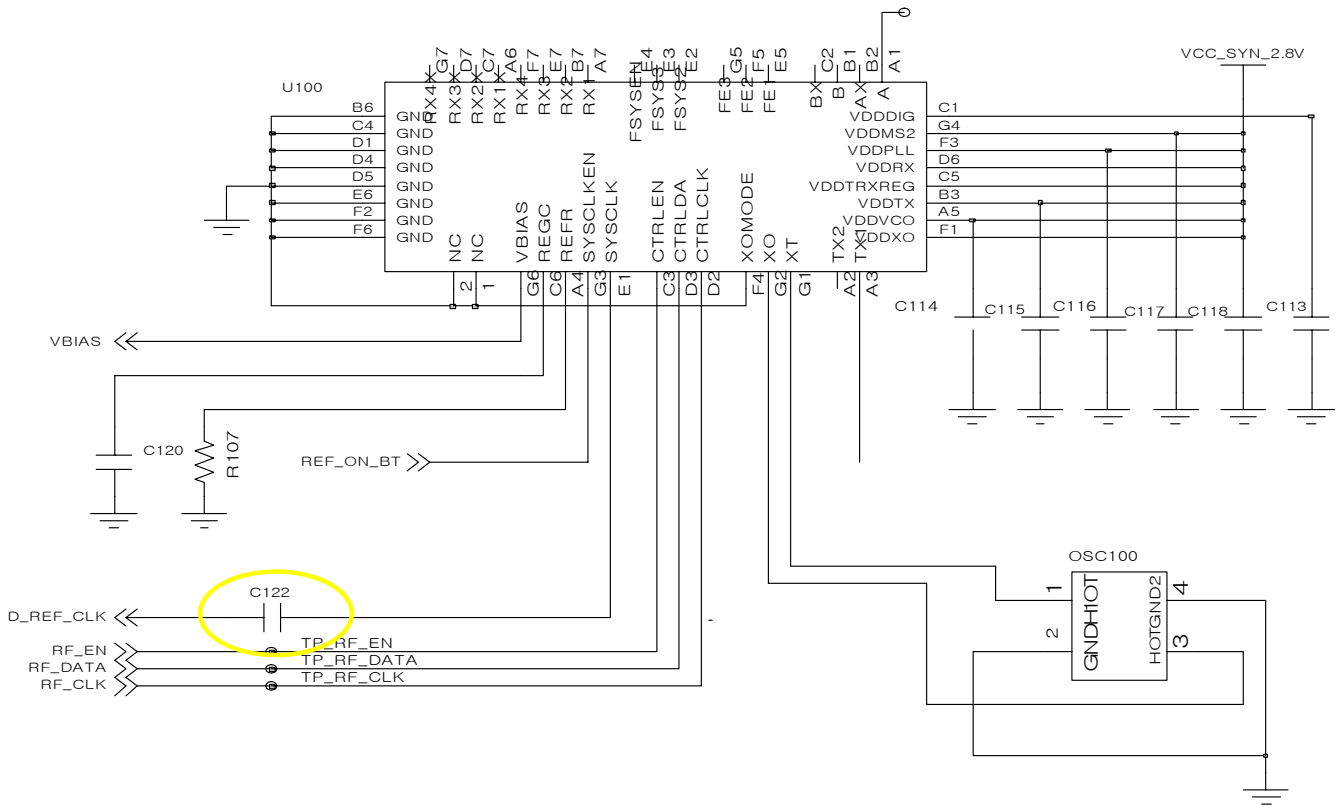

10-2. Initial

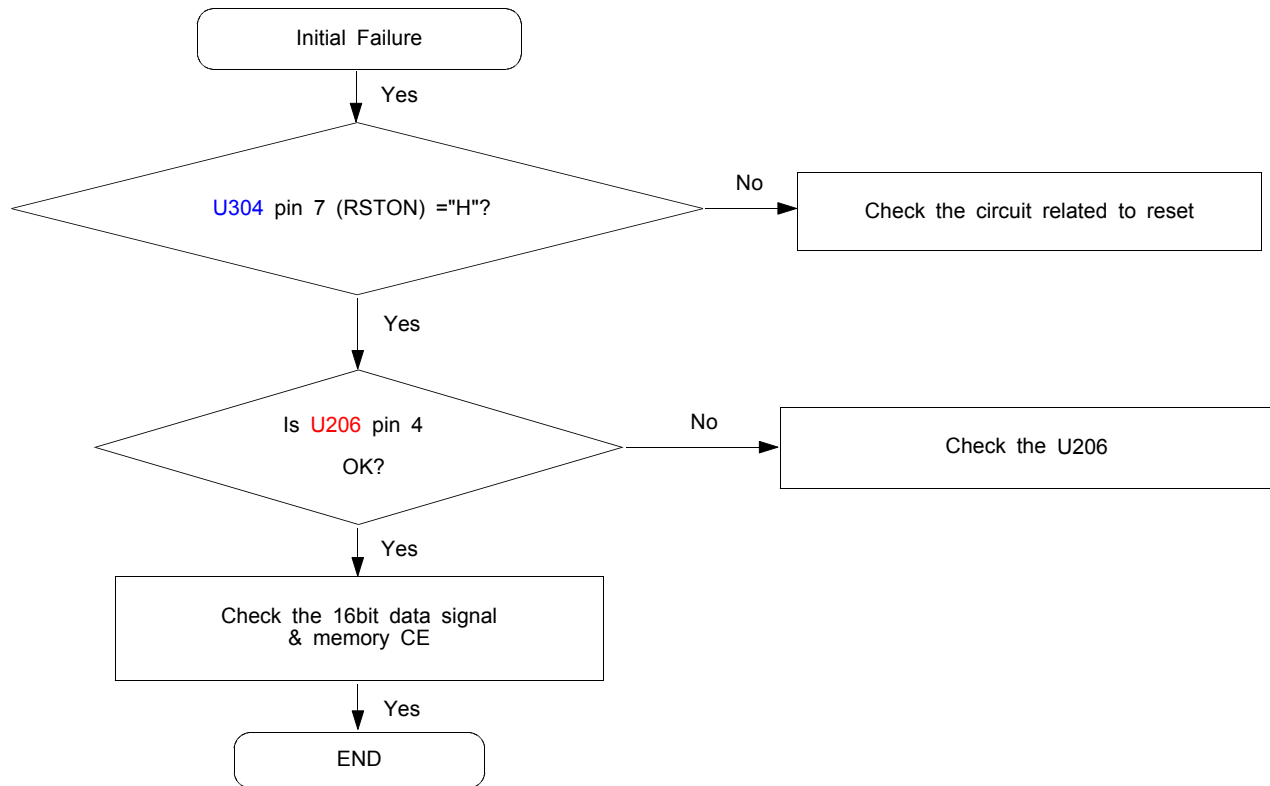

10-3. Charging Part

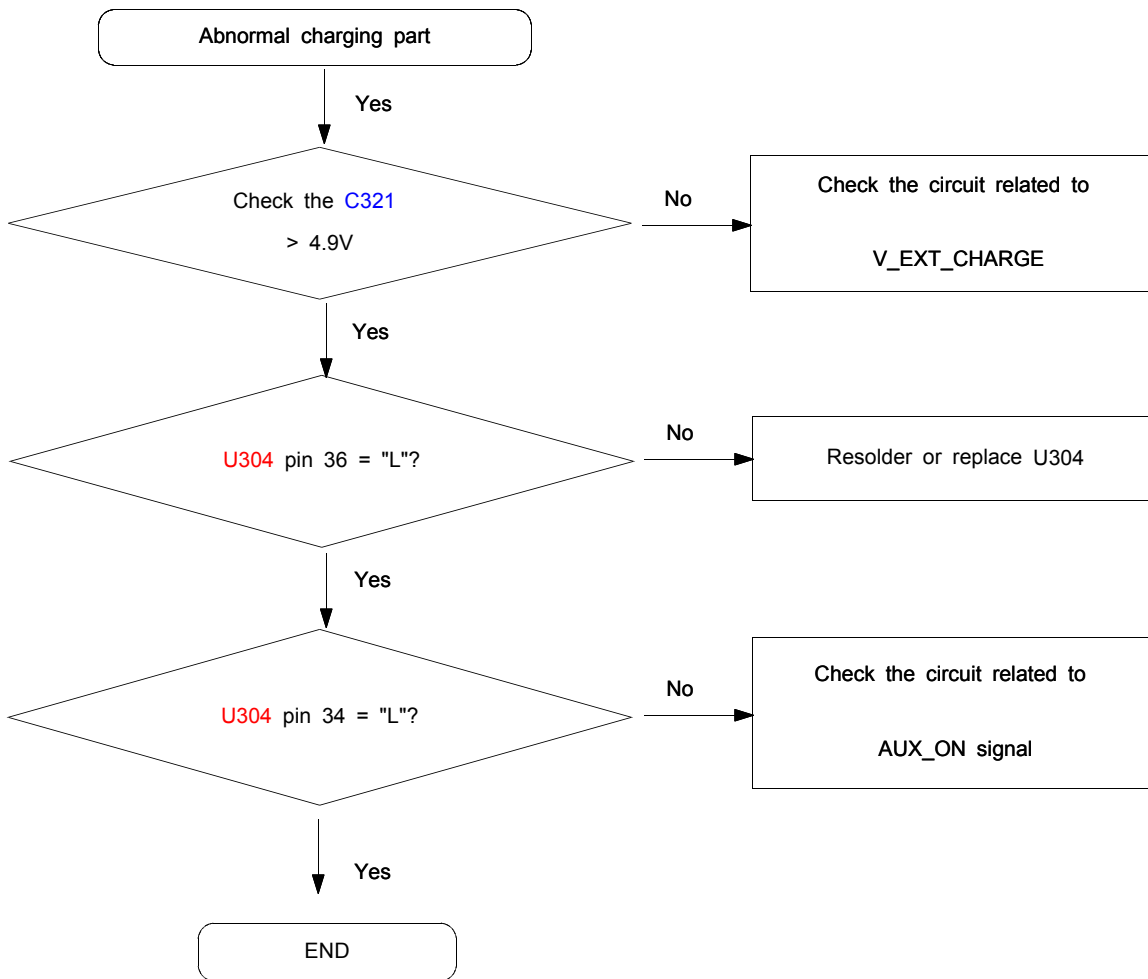

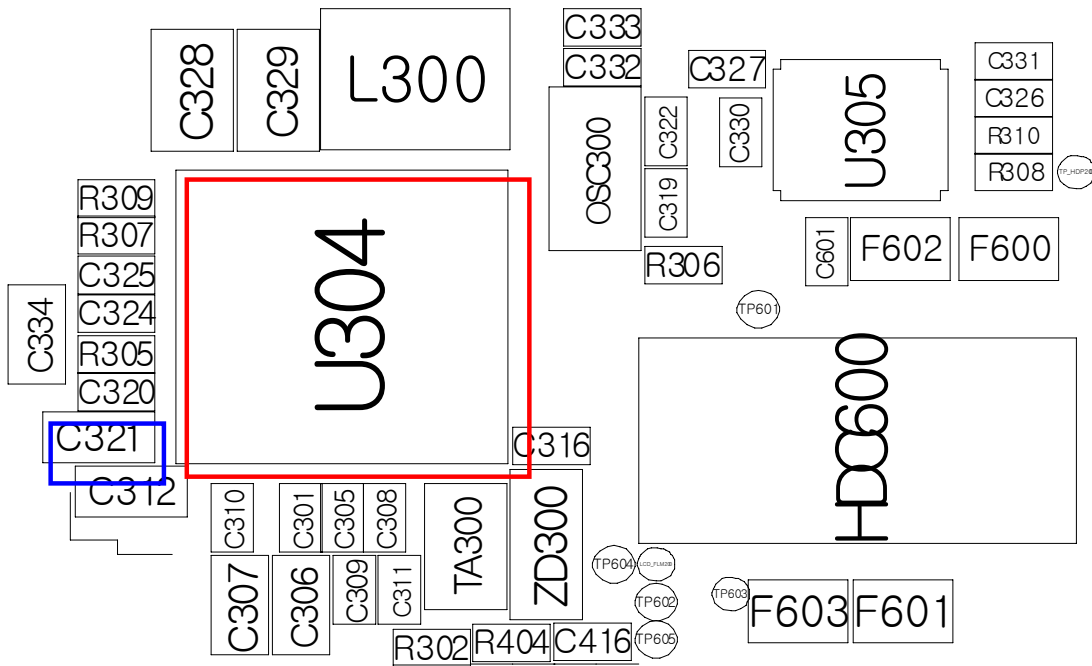
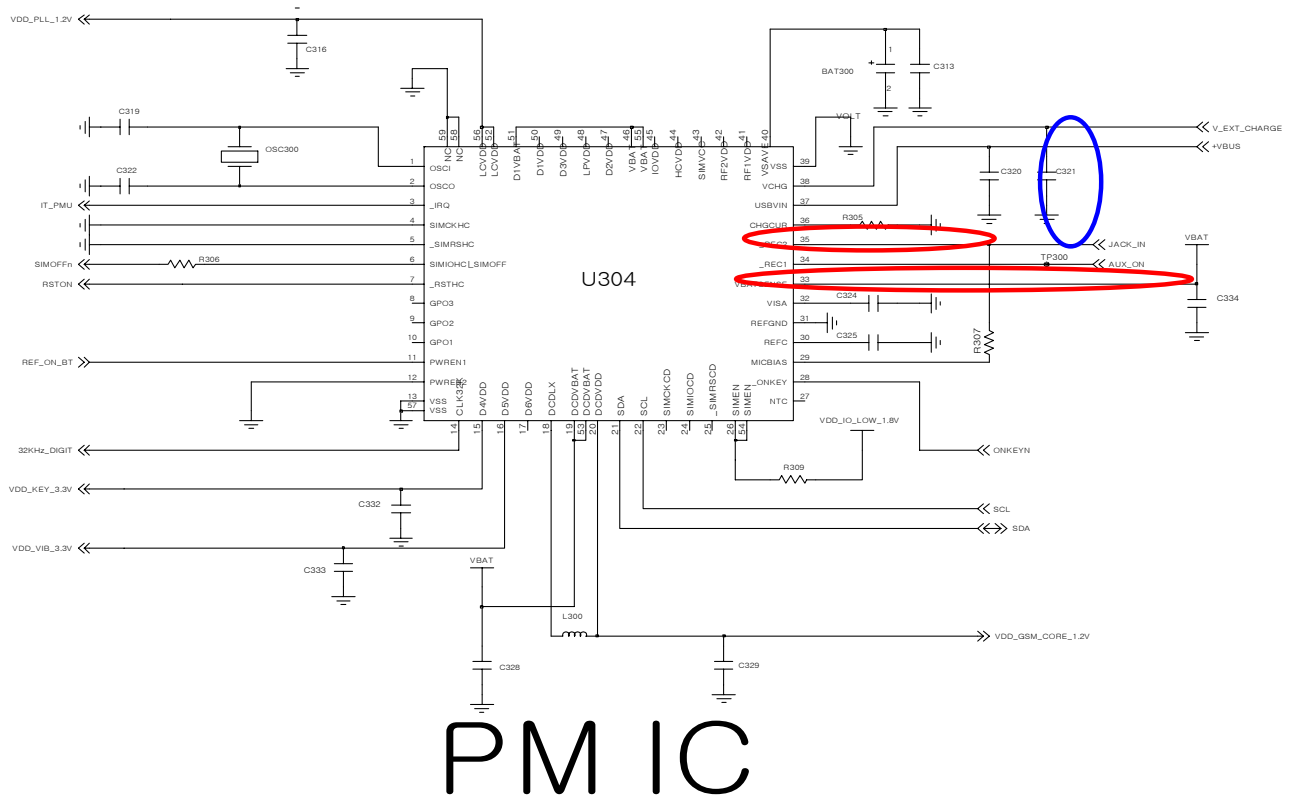

10-4. Sim Part

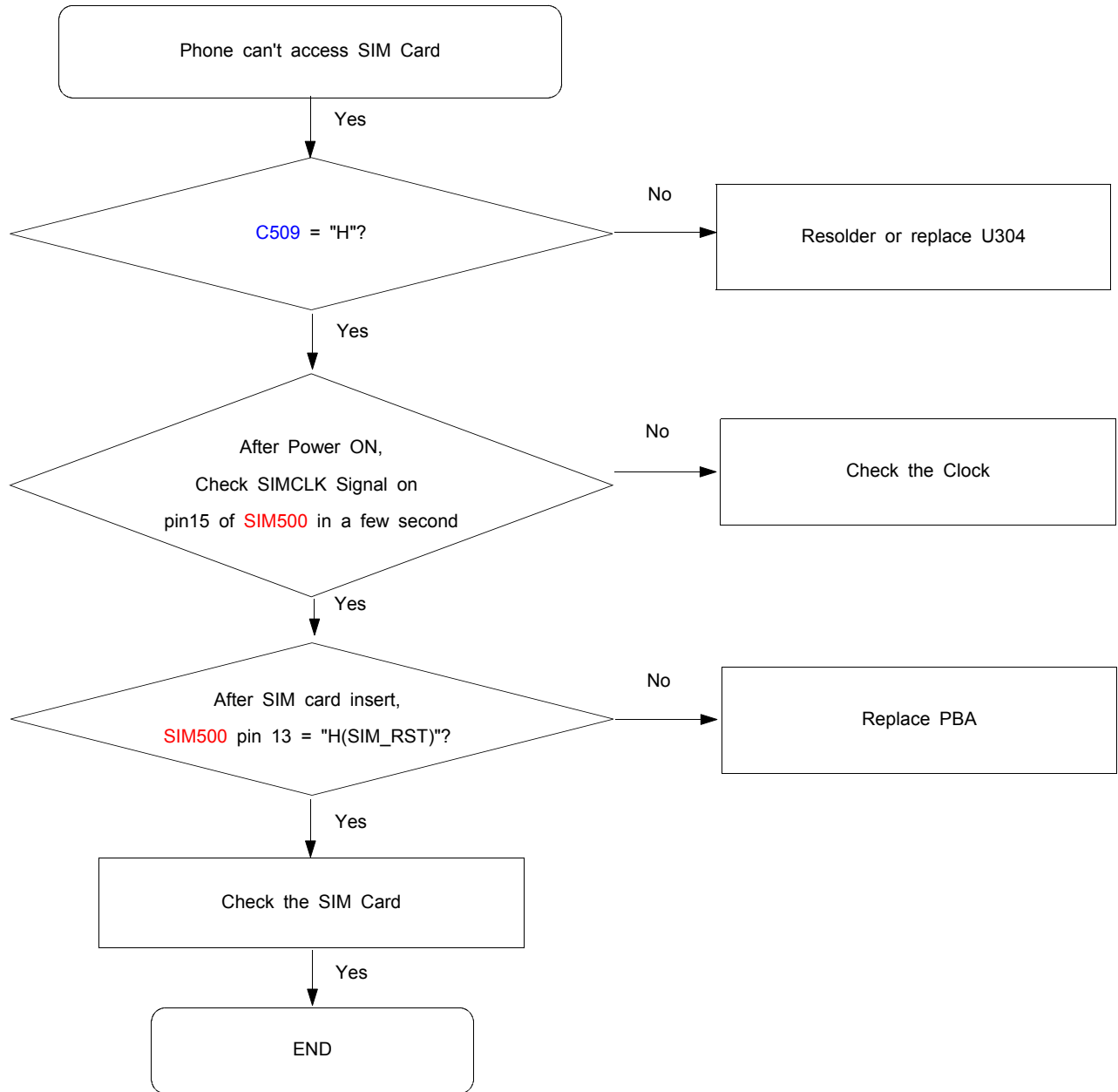

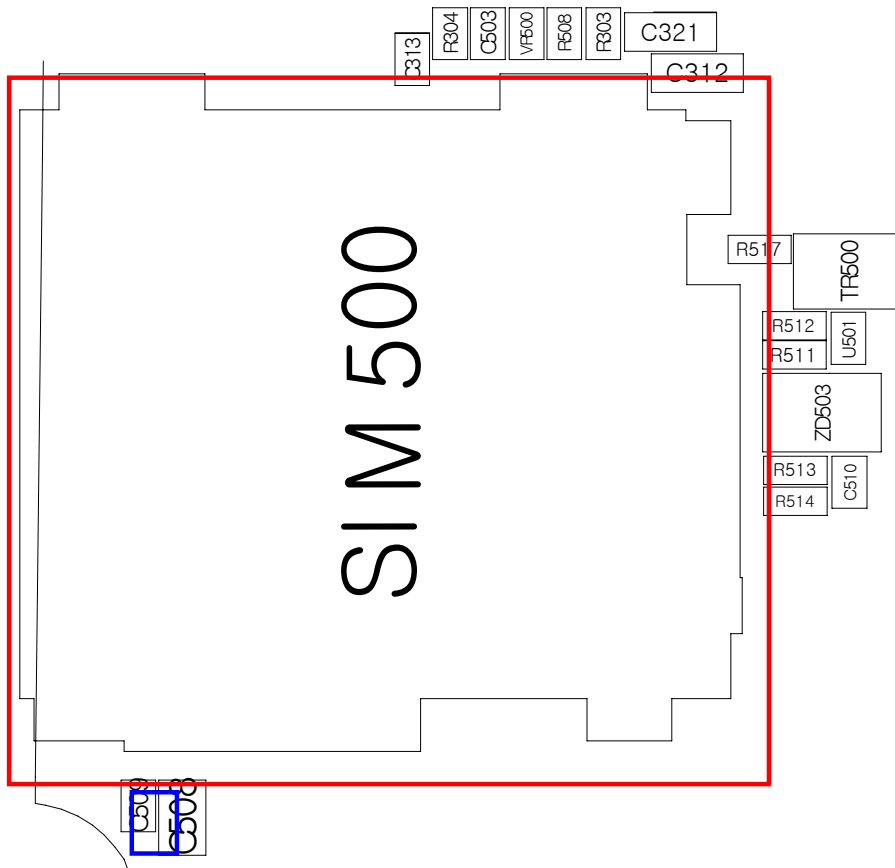
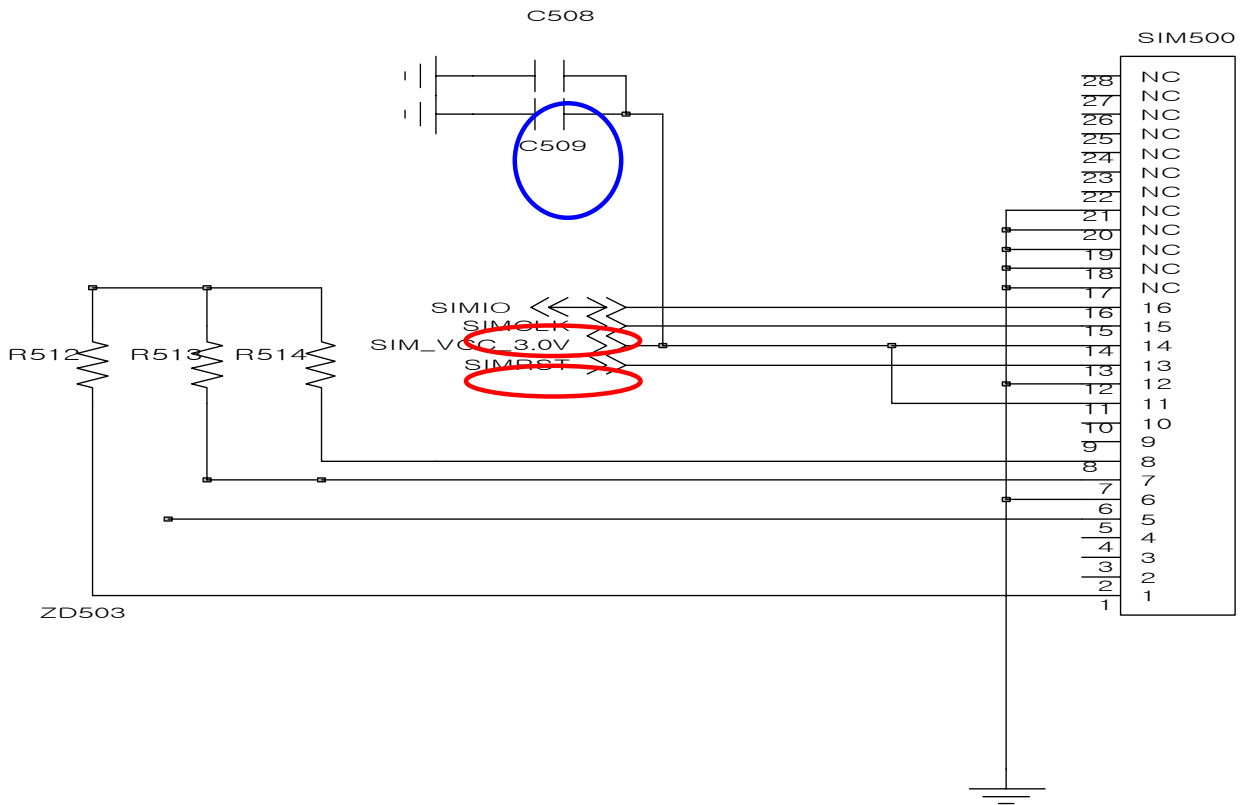

10-5. Microphone Part

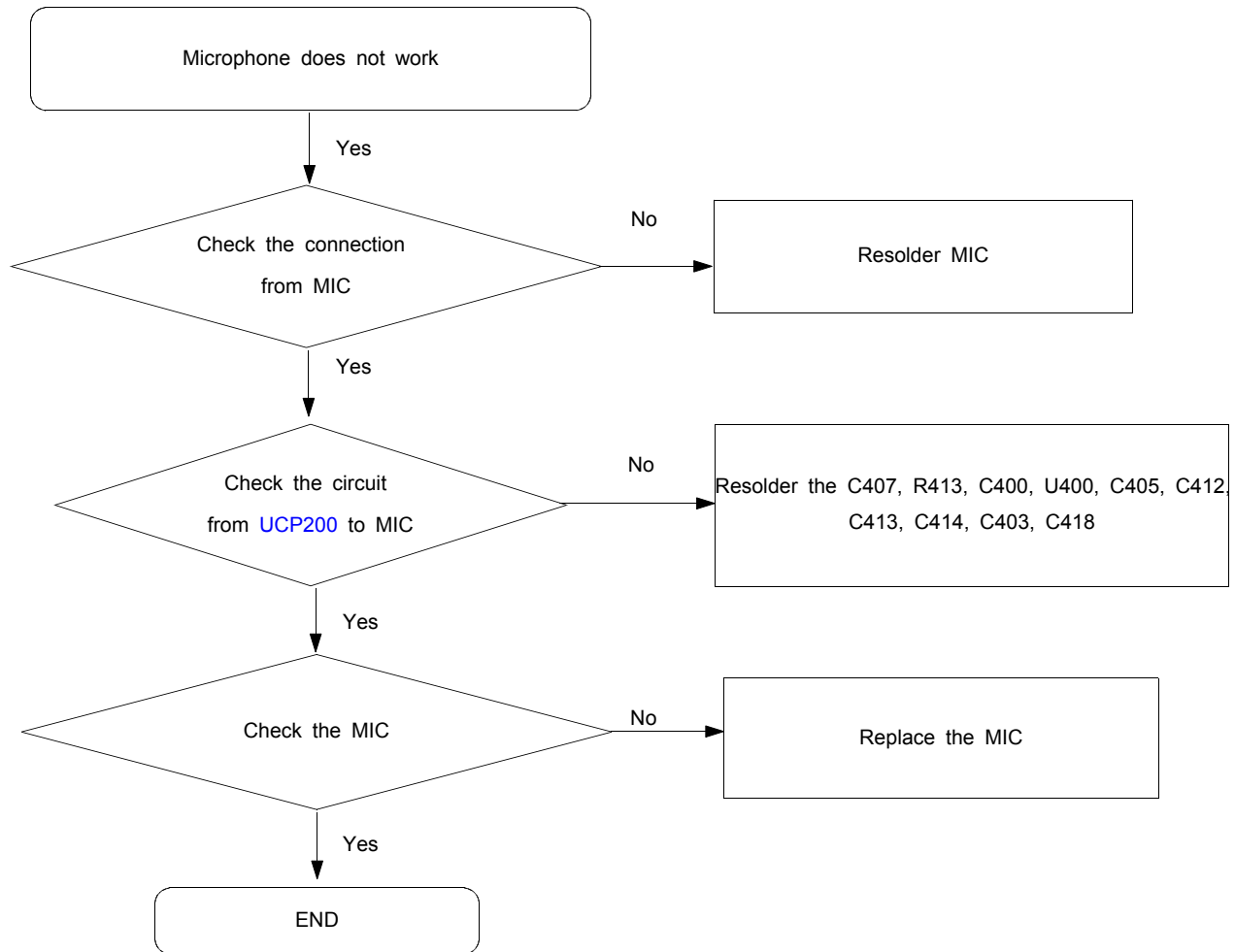

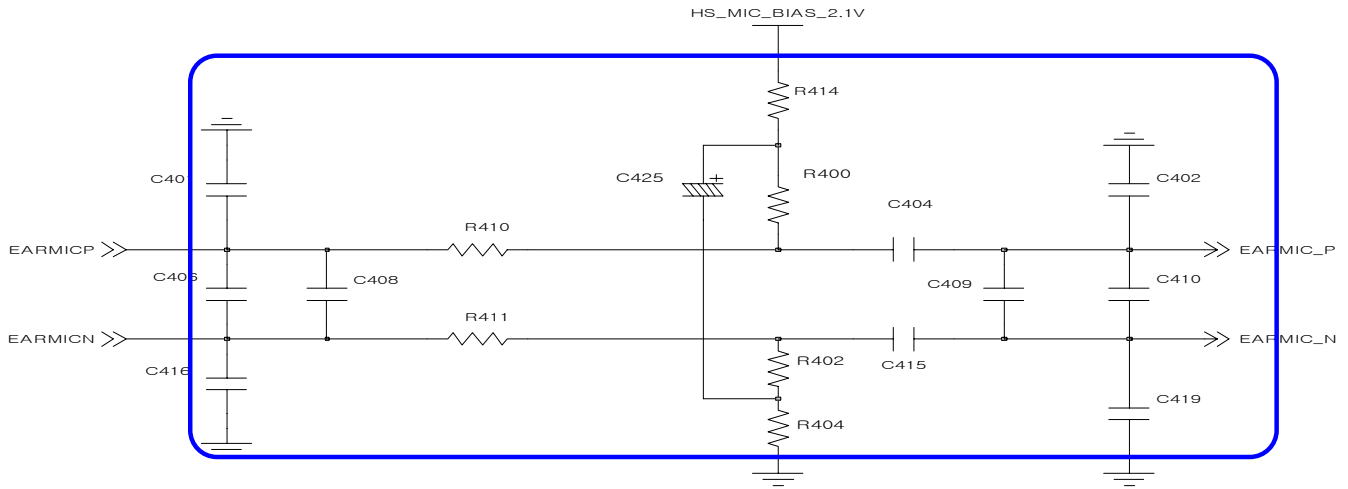

EAR MIC PATH

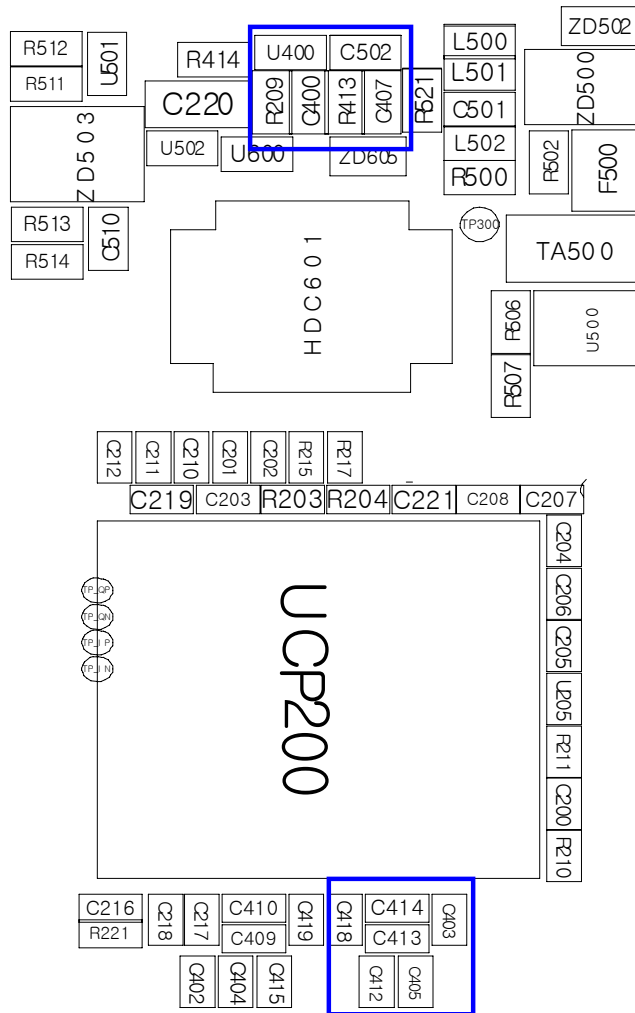

10-6. Speaker Part(Melody)

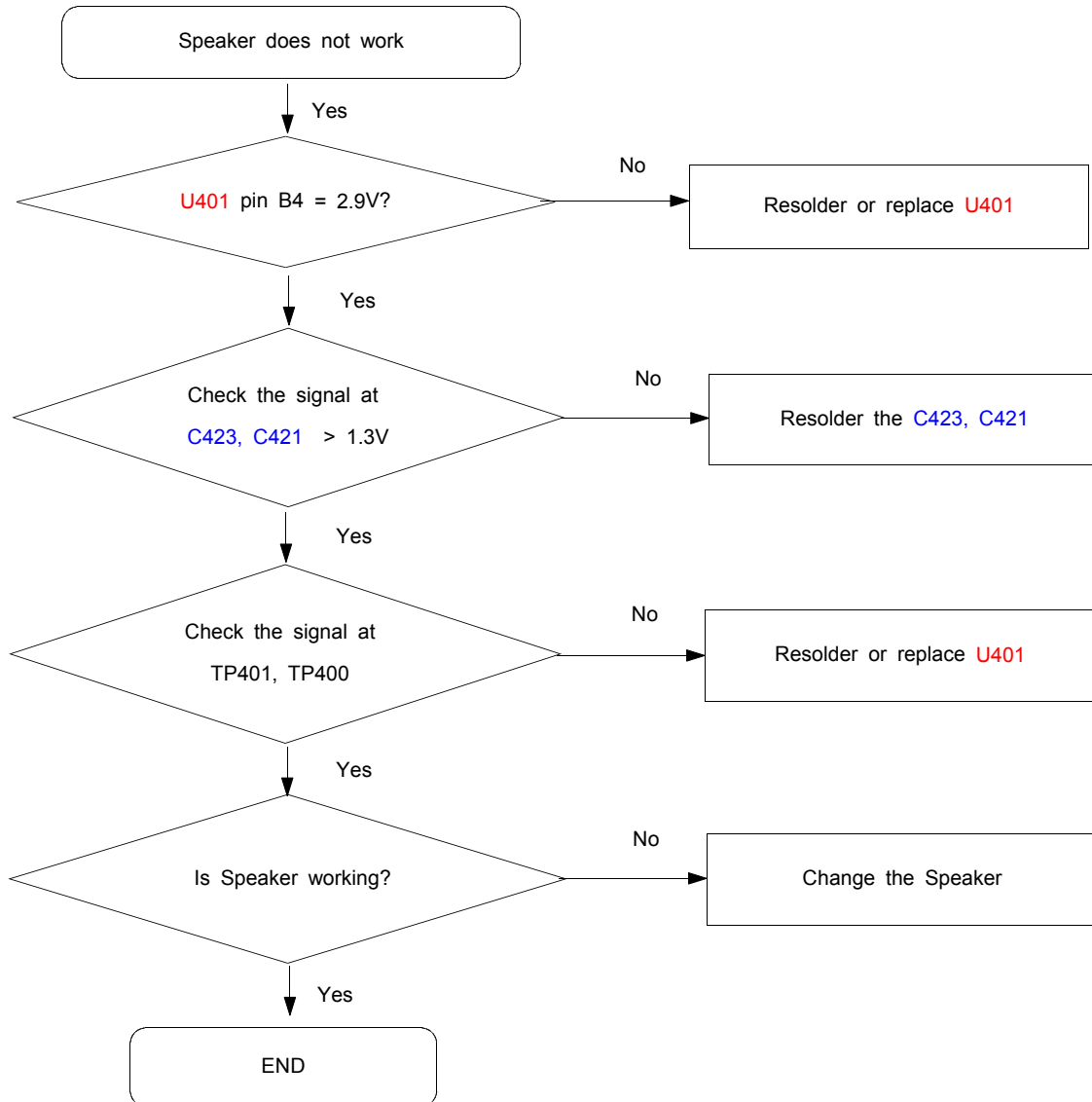

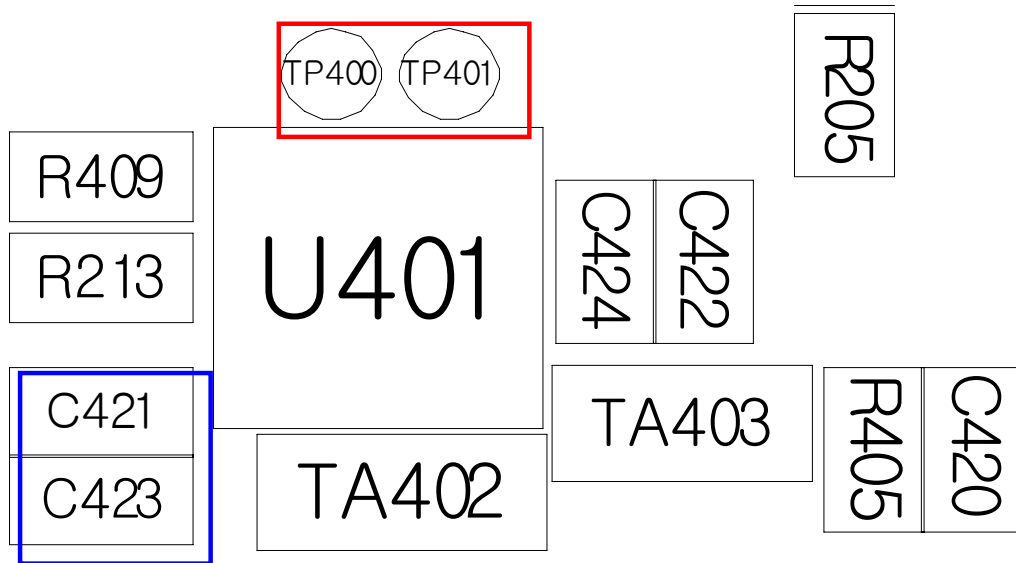
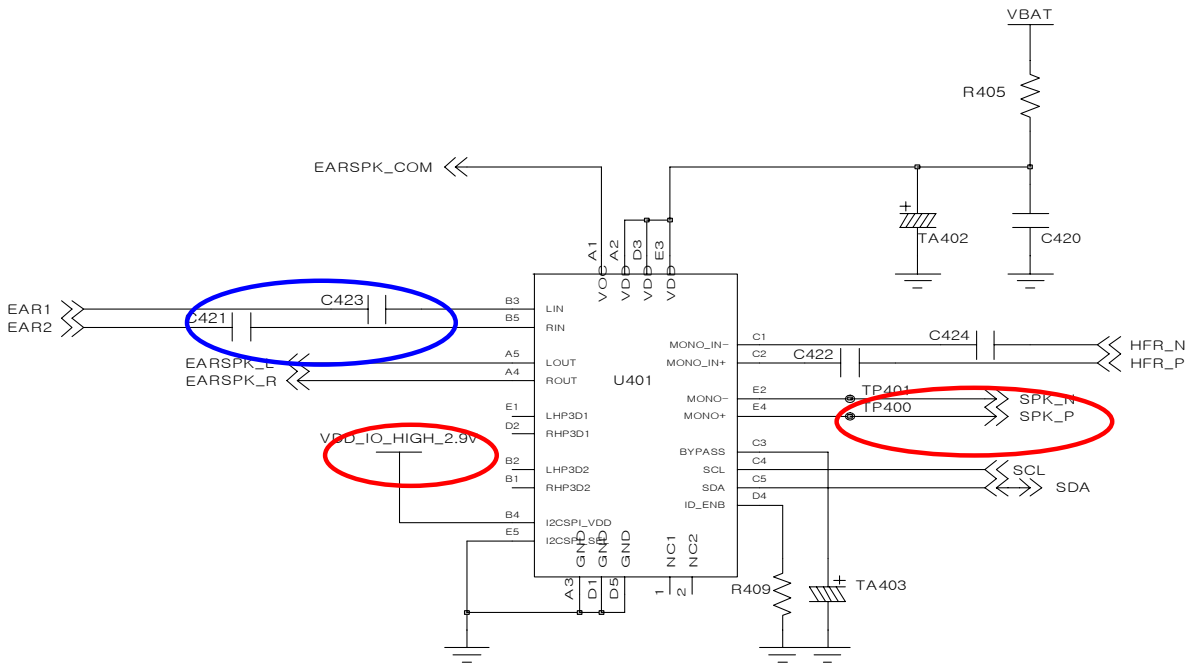

10-7. Key Data Input

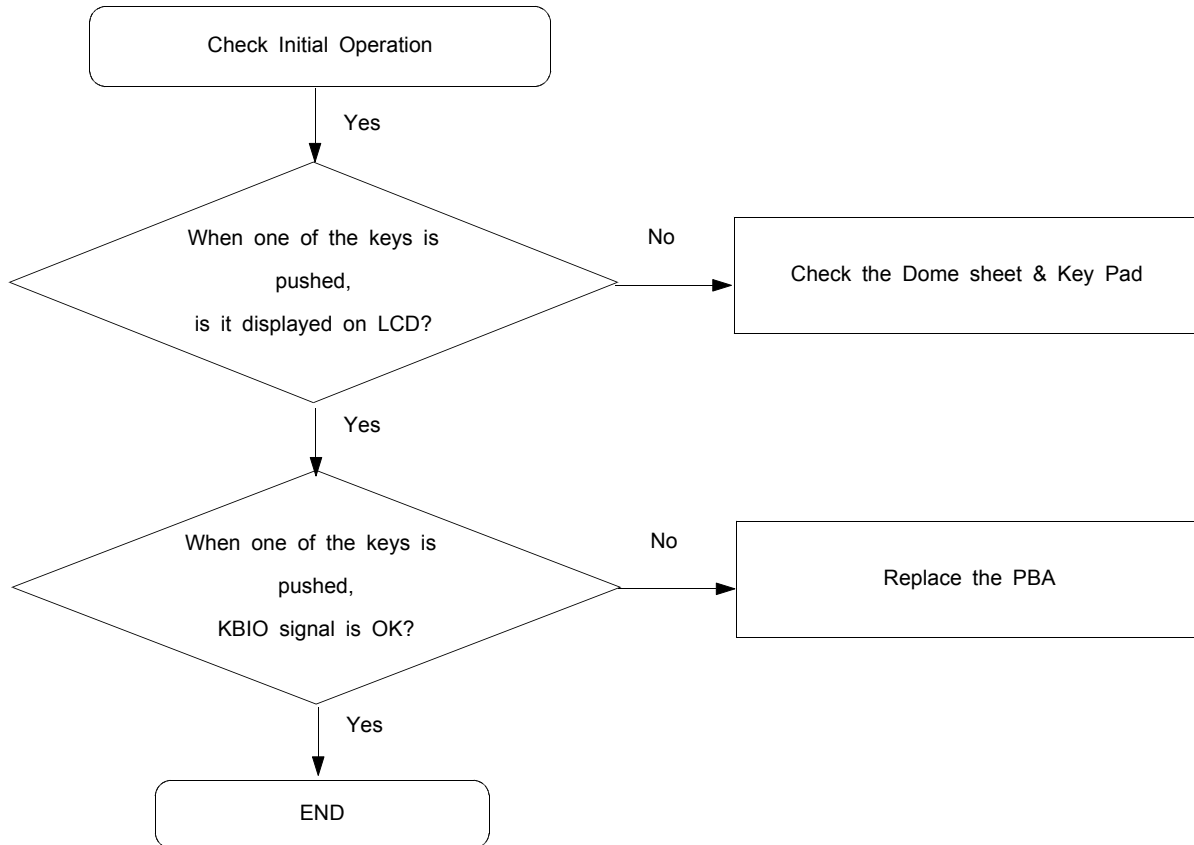

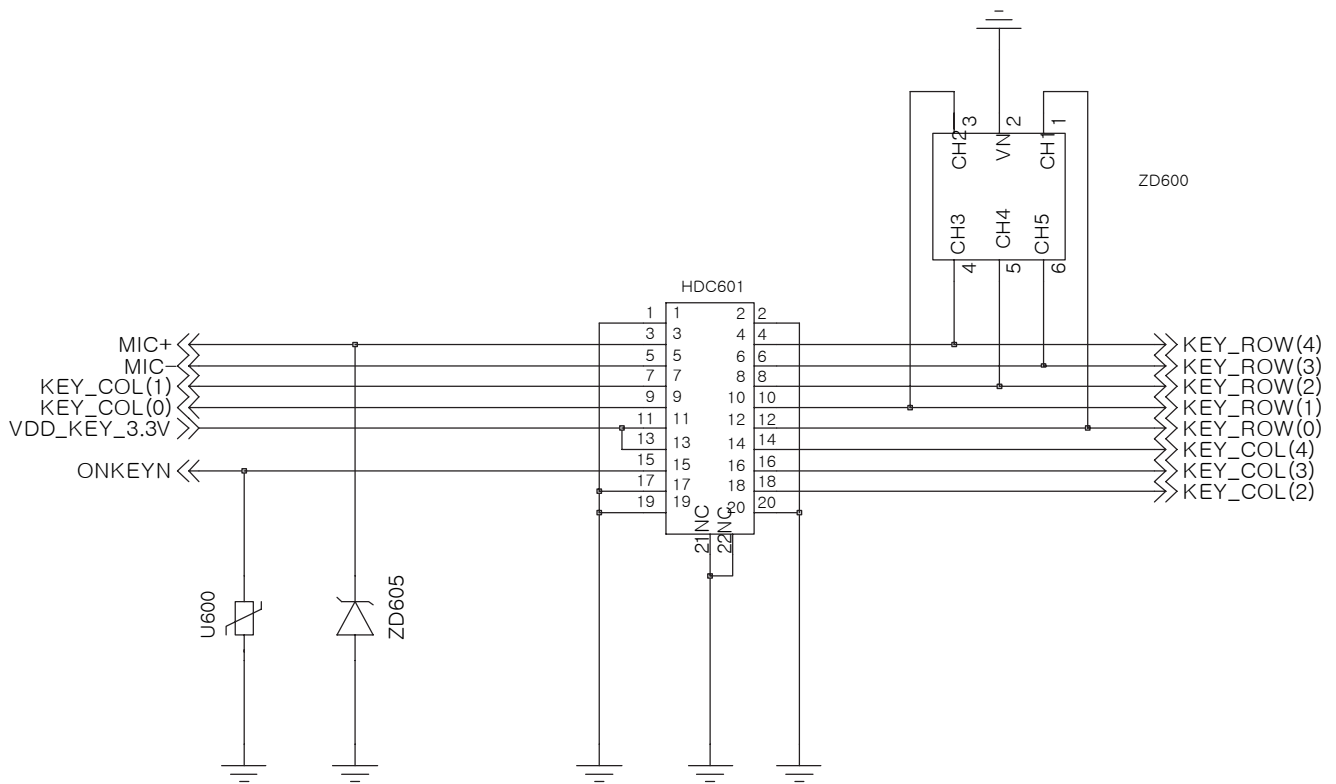

10-8. Receiver Part

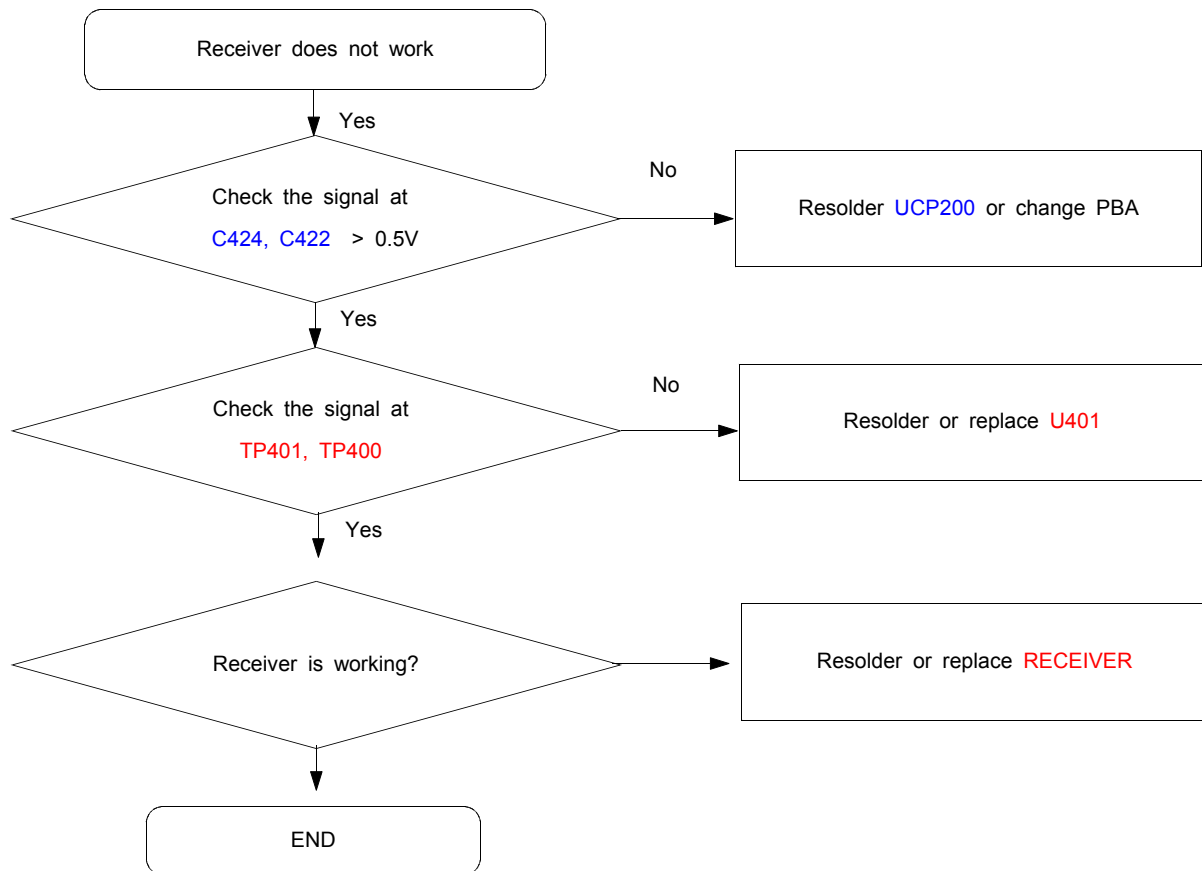

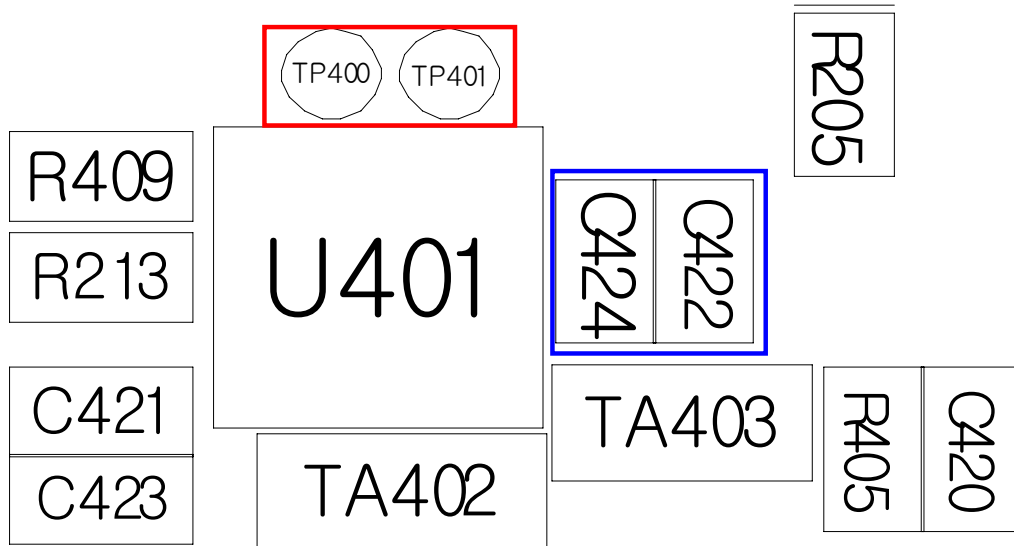
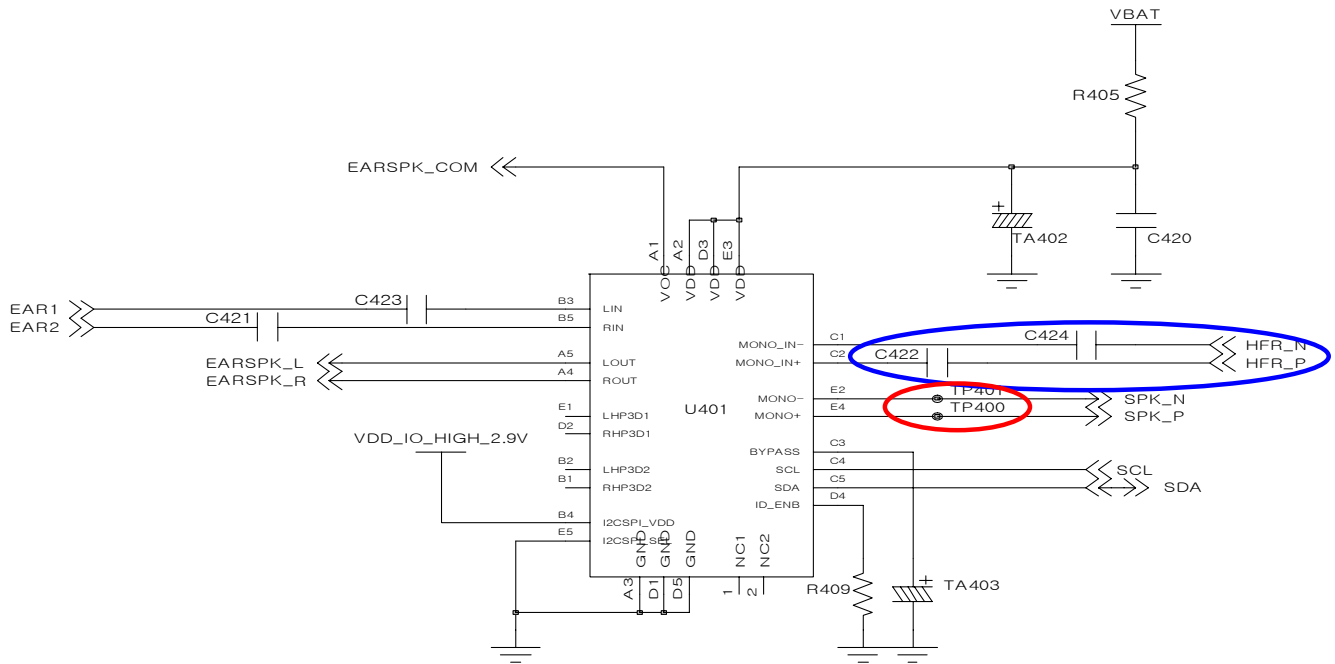

10-9. Back Light (for Color Main LCD)

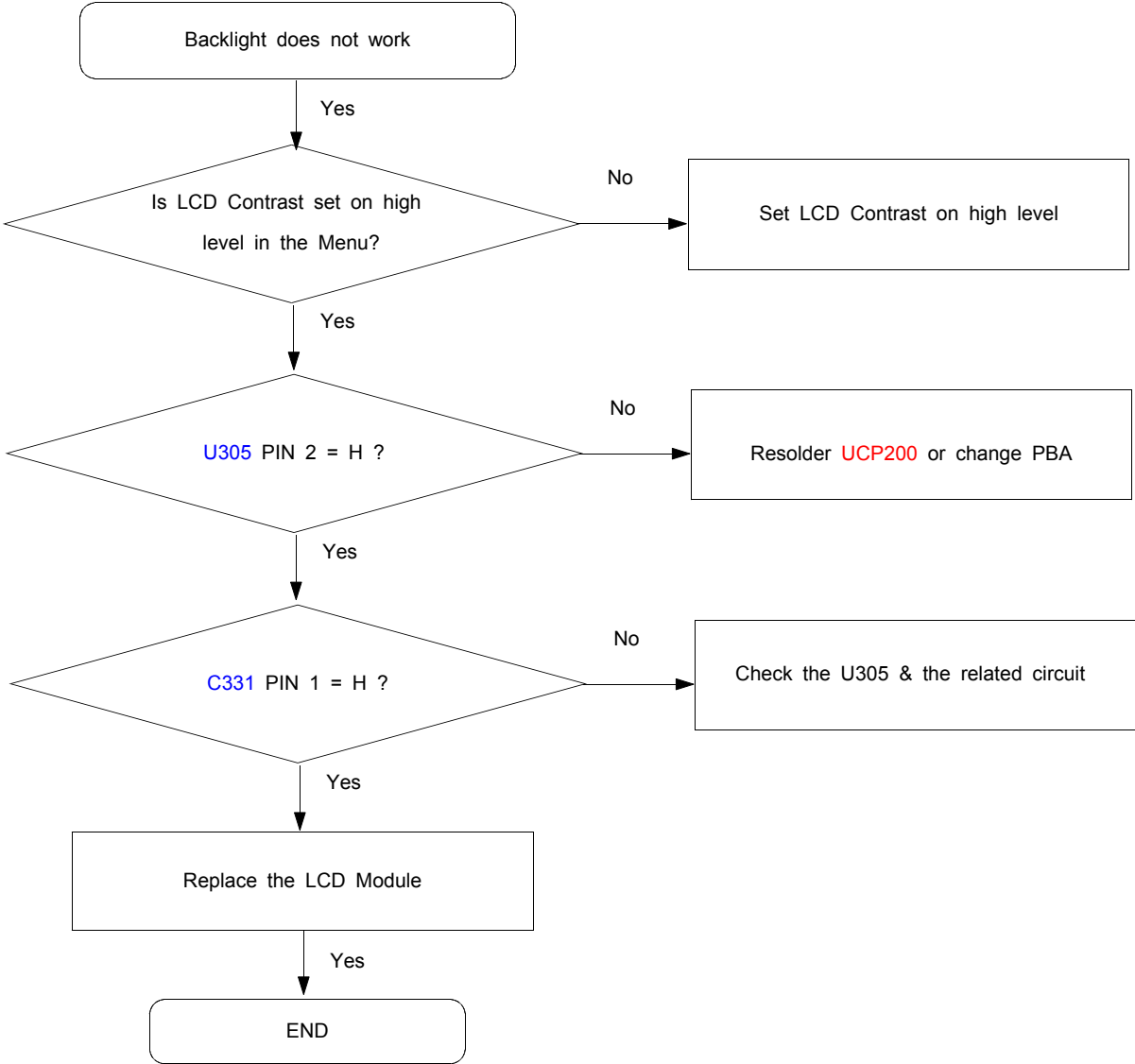

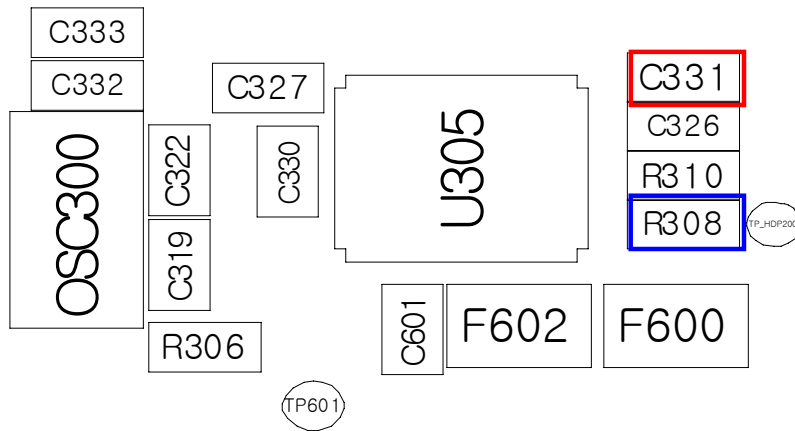
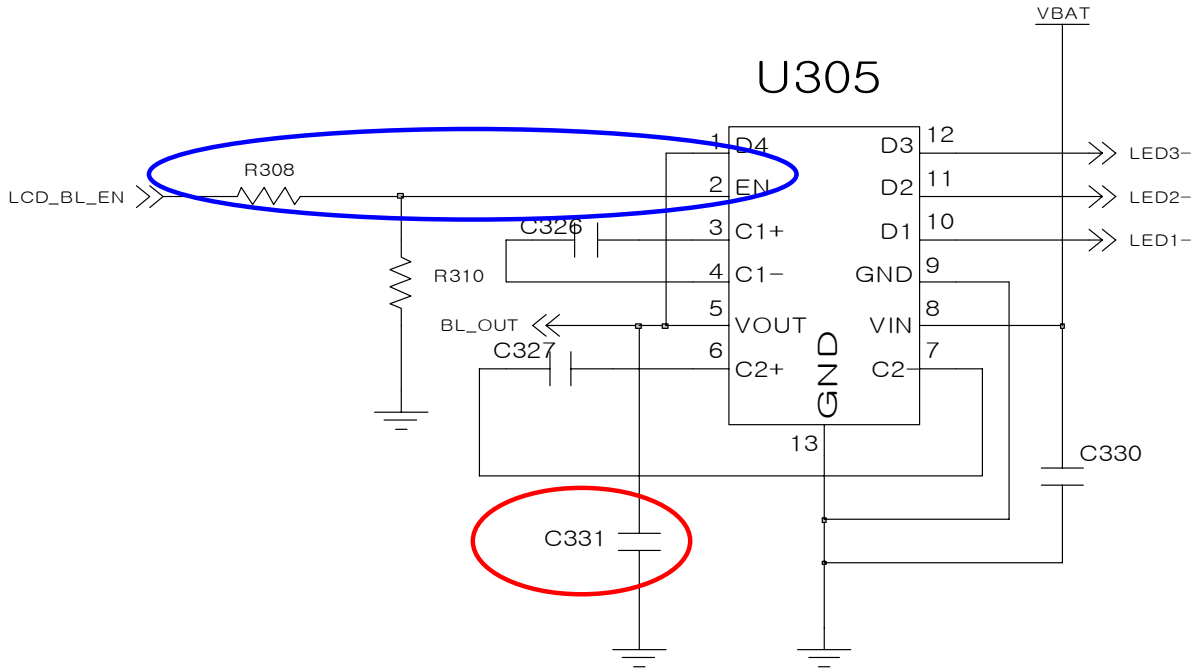

10-10. Key Back Light

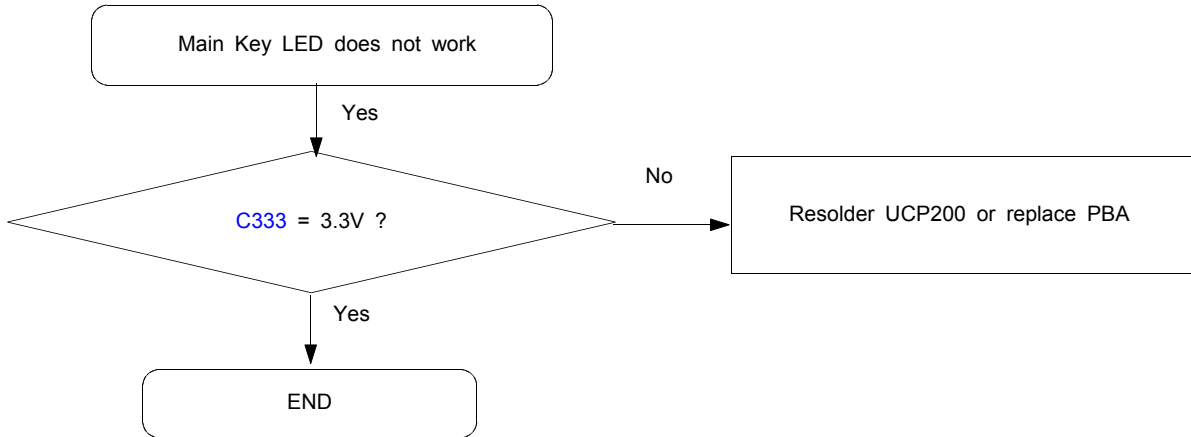

Flow Chart of Troubleshooting

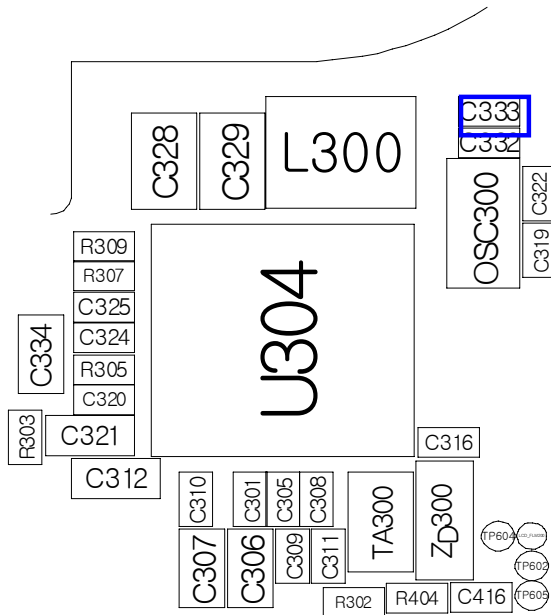
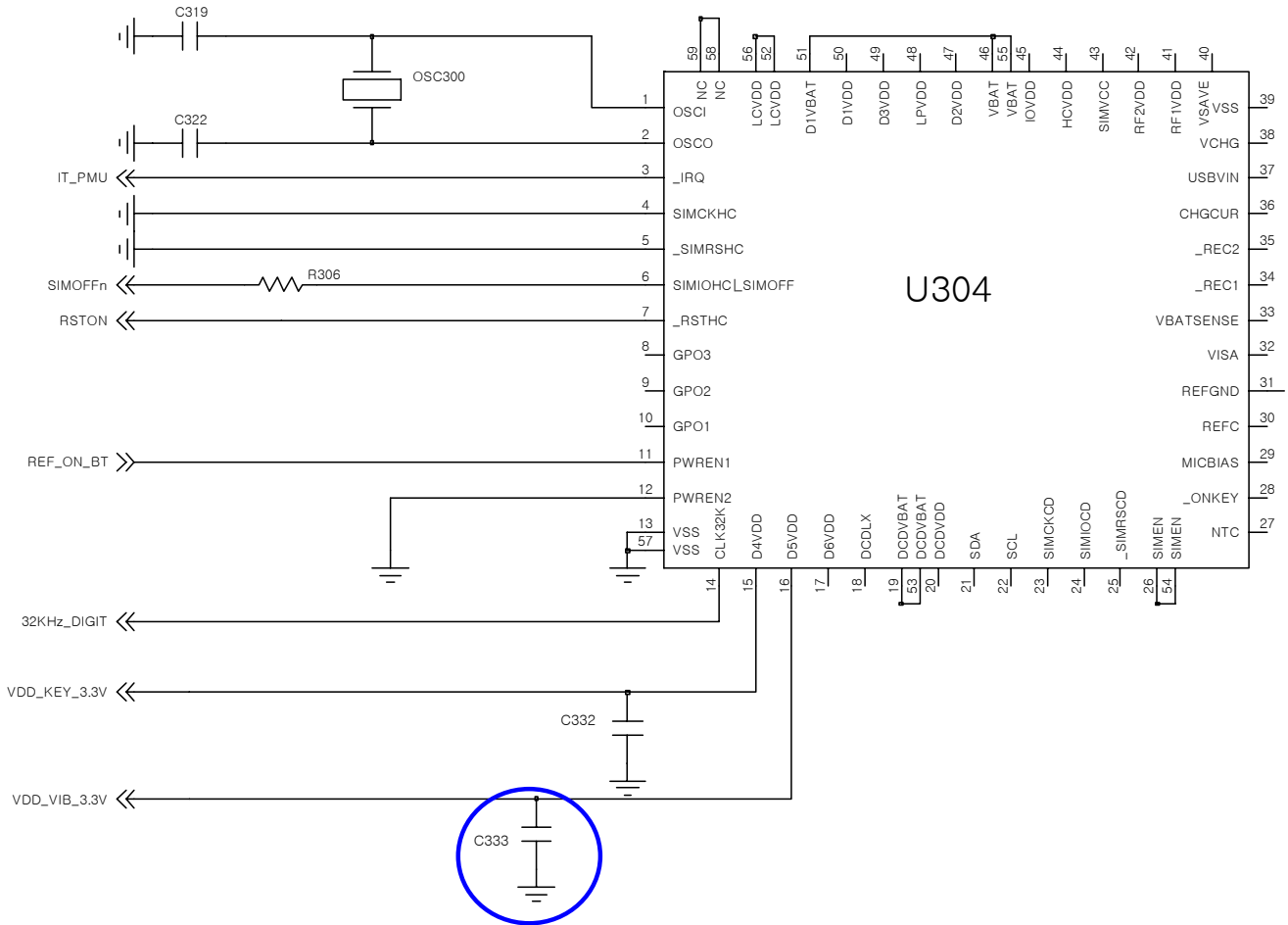

10-11. Camera part

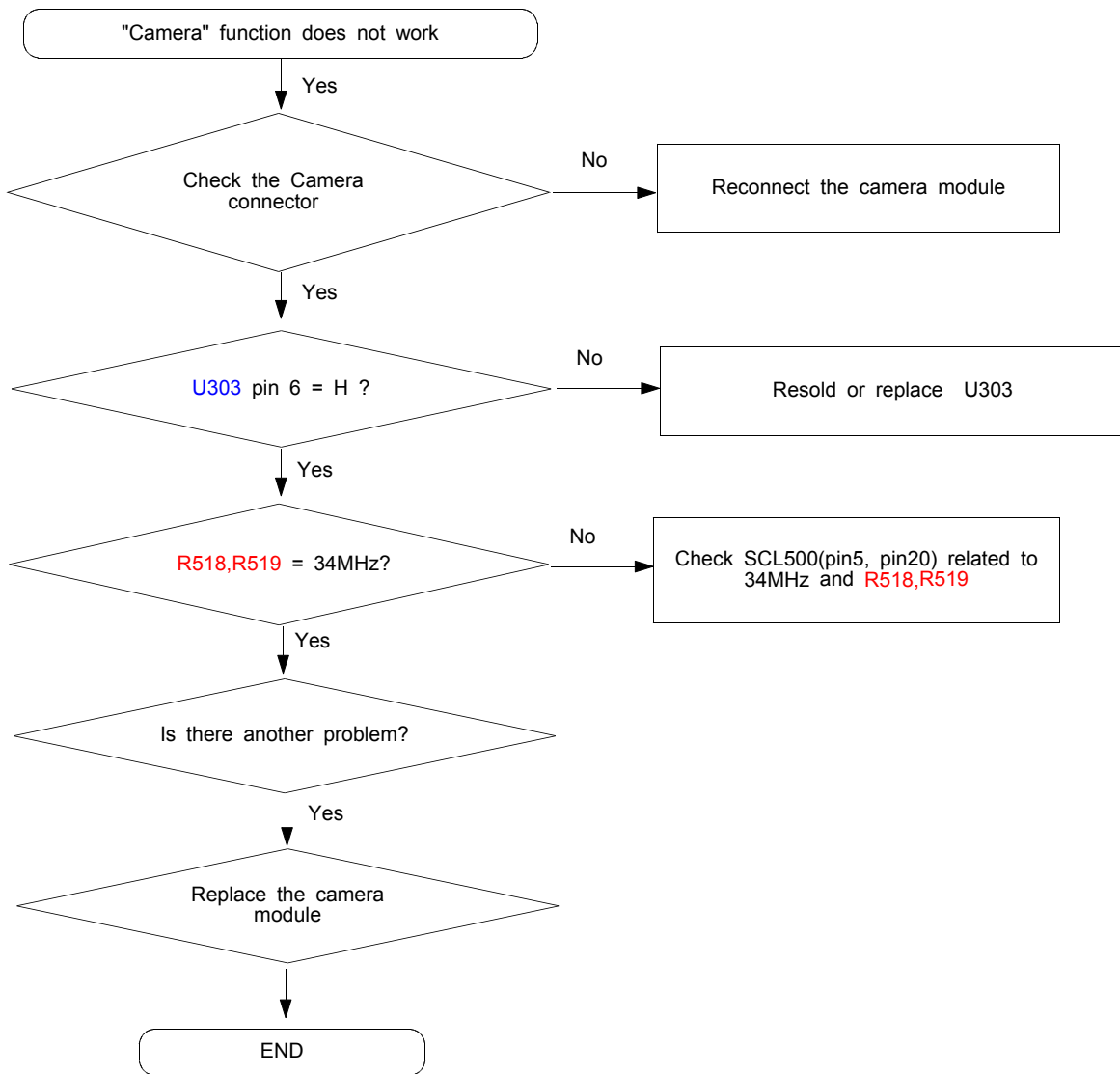

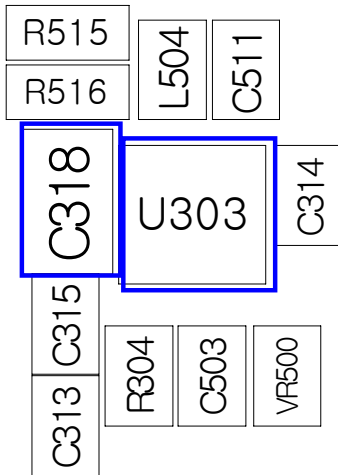
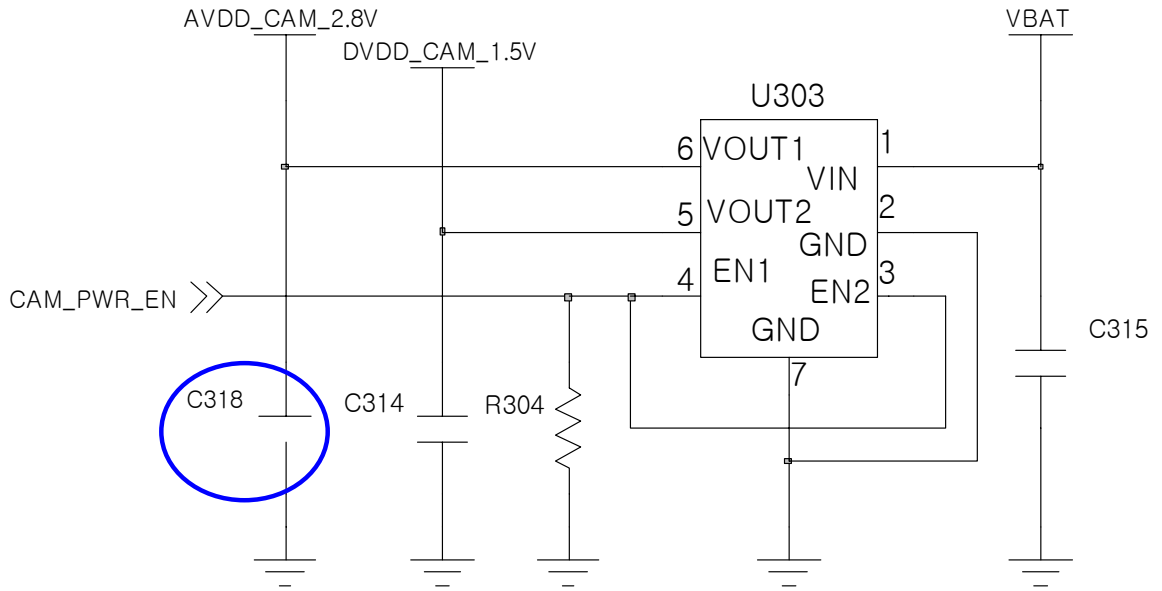

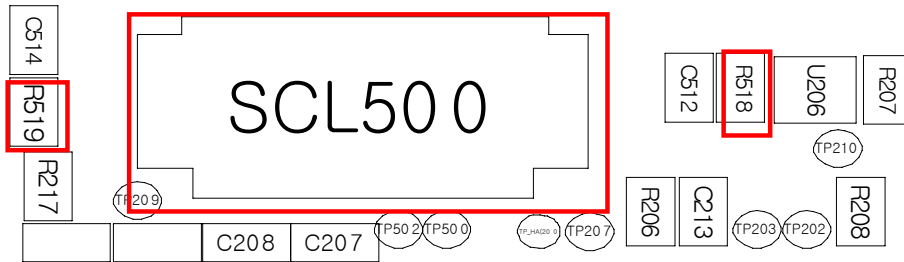
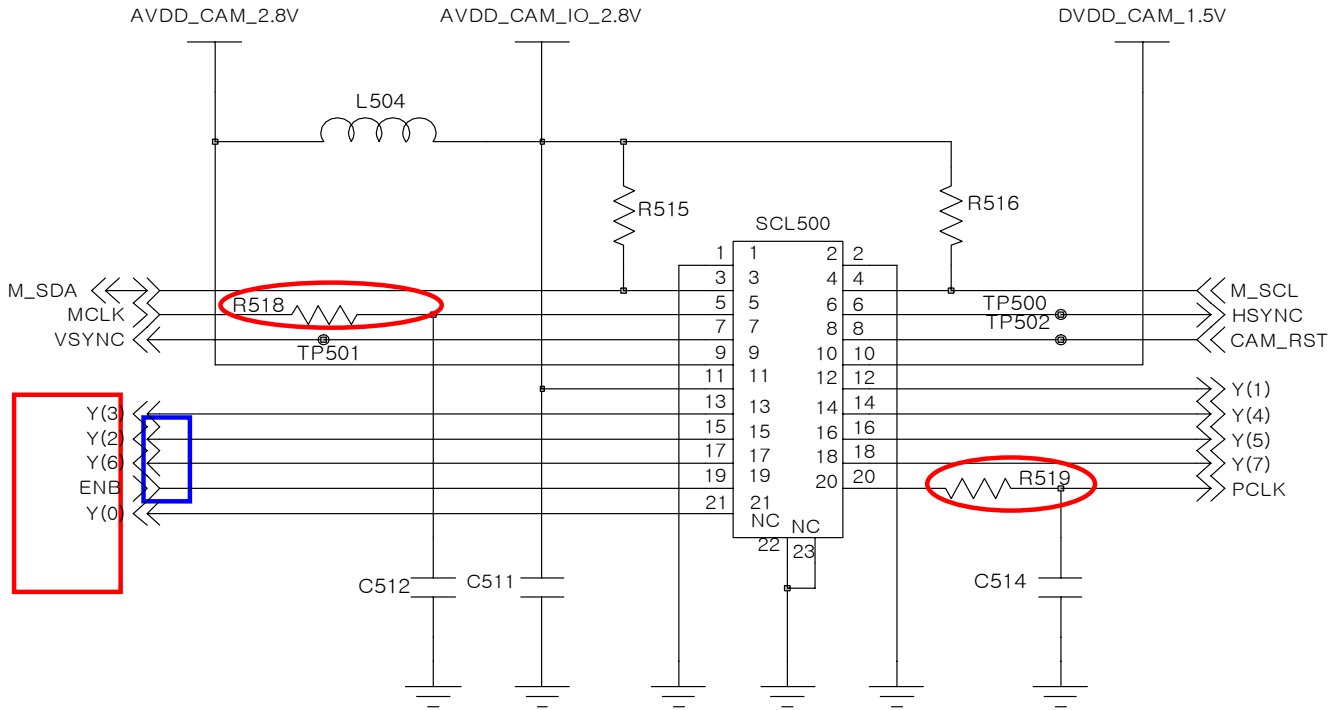

10-12. GSM Receiver

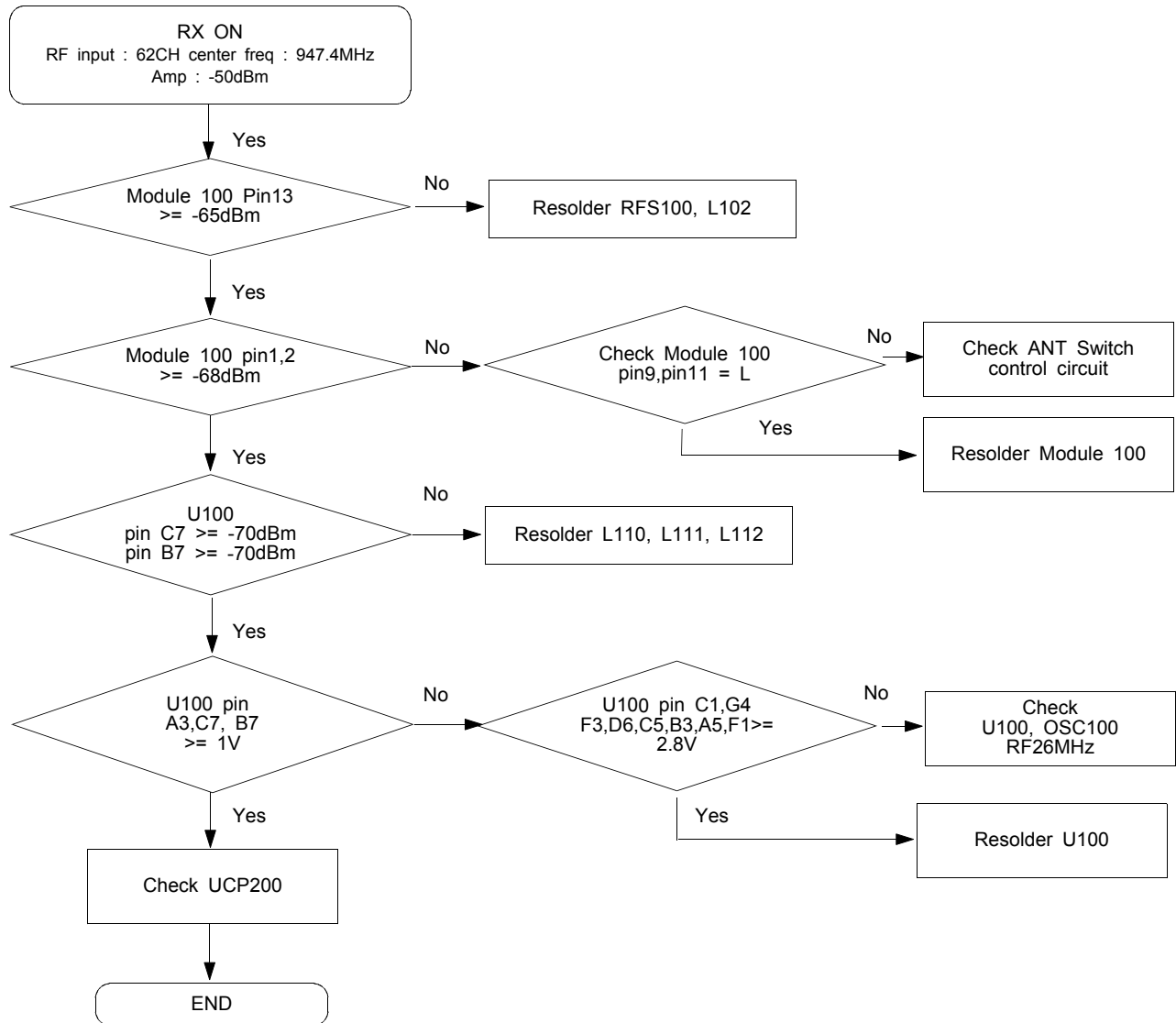

10-13. GSM Transmitter

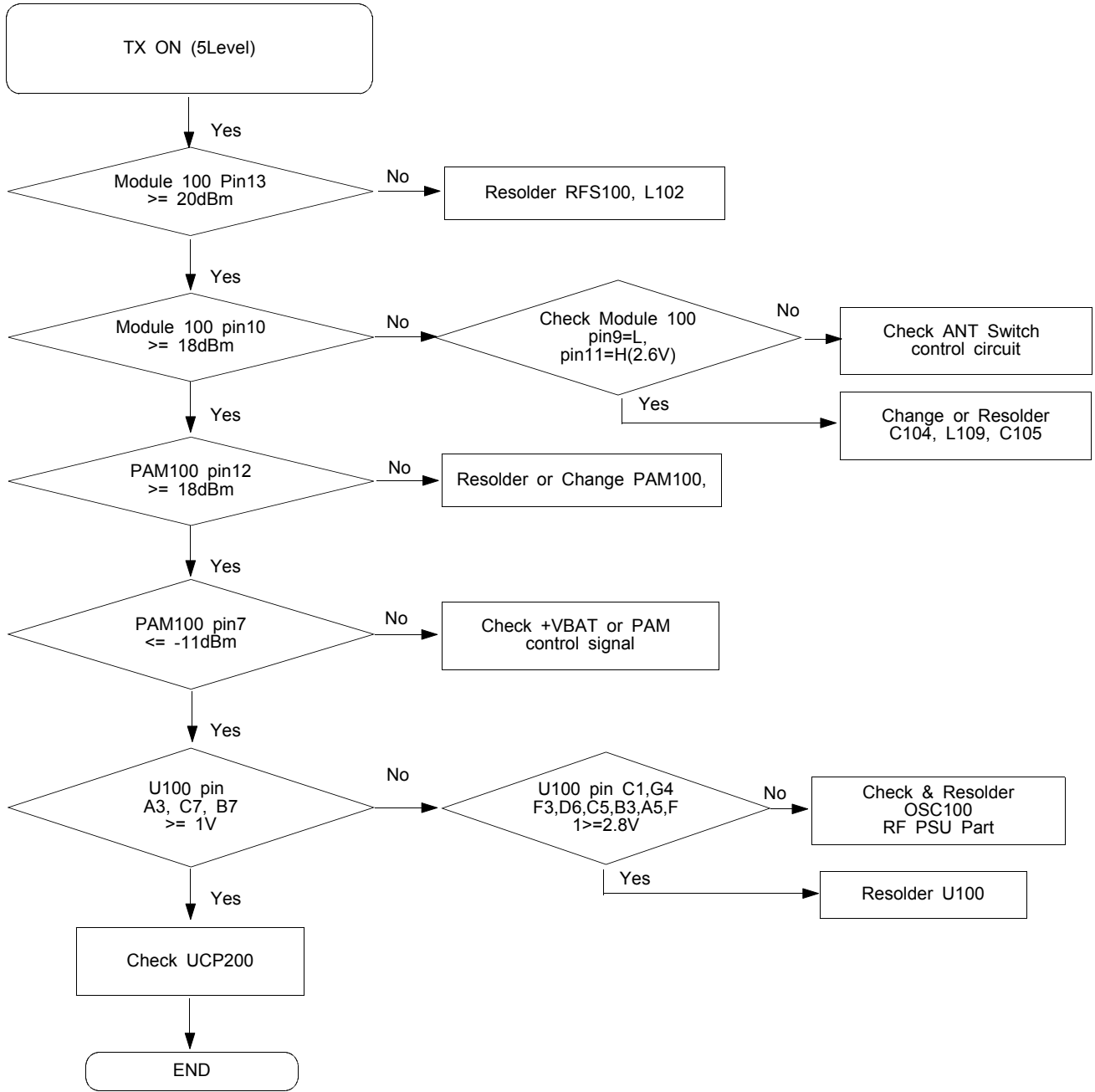

10-14. DCS Receiver

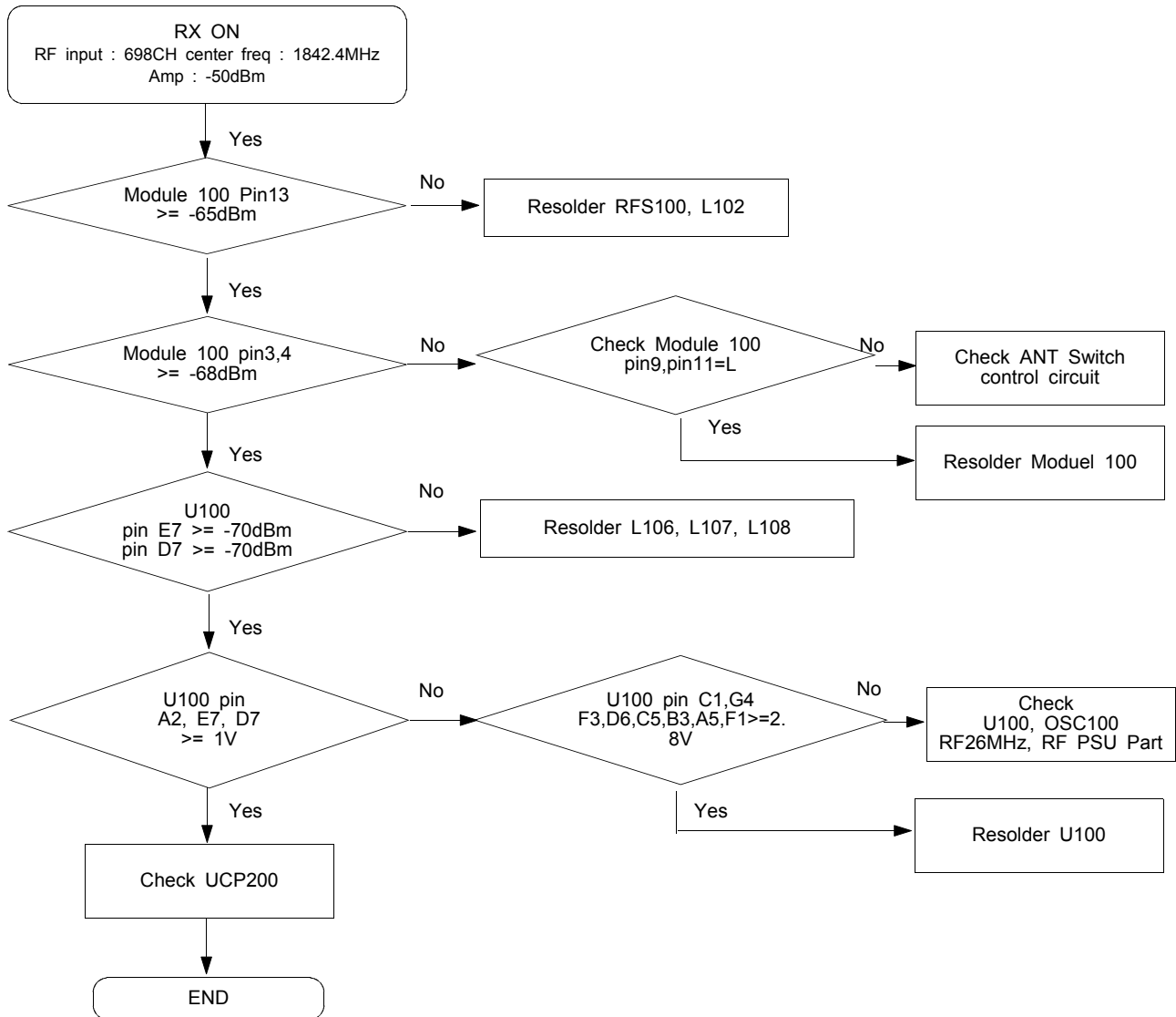

10-15. DCS Transmitter

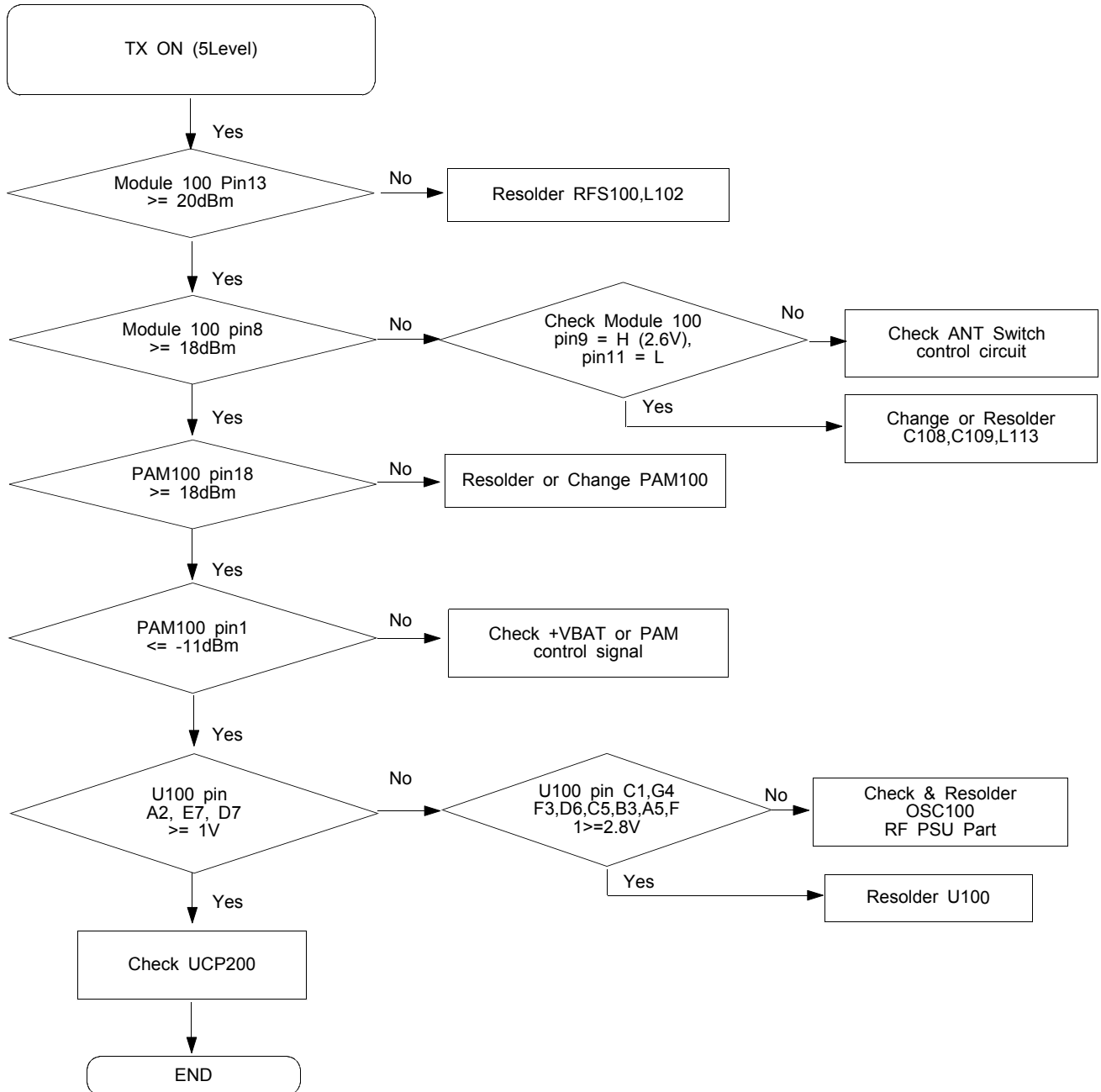

10-16. PCS Receiver

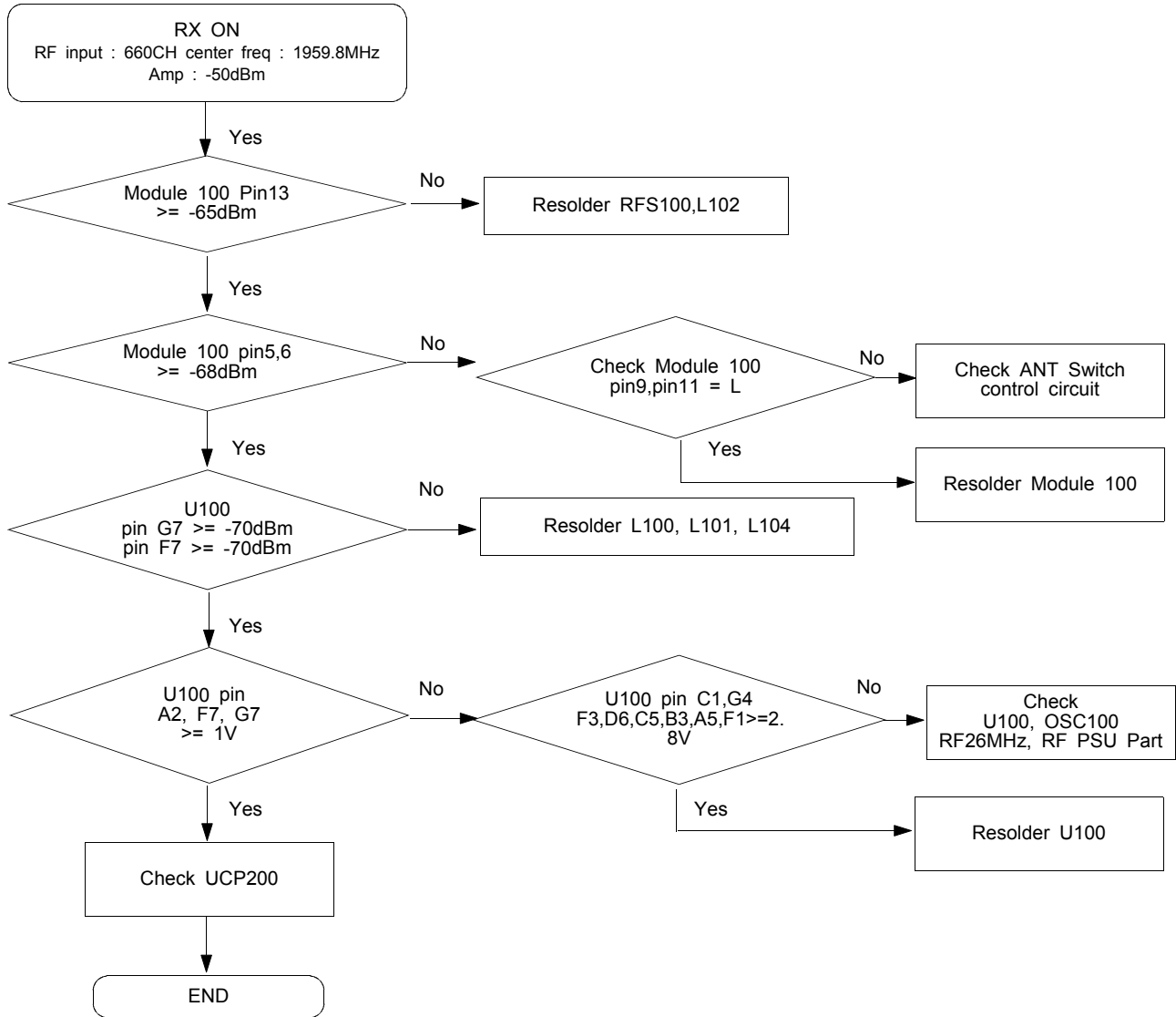

10-17. PCS Transmitter

