

**SAMSUNG**

# GSM TELEPHONE

## SGH-E880

# **SERVICE** *Manual*

**GSM TELEPHONE**



**CONTENTS**

1. Specification
2. Flow Chart of Troubleshooting
3. Exploded Views and Parts List
4. Electrical Parts List
5. PCB Diagrams
6. Block Diagrams

---

# 1. SGH-E880 Specification

---

## 1-1. GSM General Specification

	<b>GSM900 Phase 1</b>	<b>EGSM 900 Phase 2</b>	<b>DCS1800 Phase 1</b>	<b>PCS1900</b>
Freq. Band[MHz] Uplink/Downlink	890~915 935~960	880~915 925~960	1710~1785 1805~1880	1850~1910 1930~1990
ARFCN range	1~124	0~124 & 975~1023	512~885	512~810
Tx/Rx spacing	45MHz	45MHz	95MHz	80MHz
Mod. Bit rate/ Bit Period	270.833kbps 3.692us	270.833kbps 3.692us	270.833kbps 3.692us	270.833kbps 3.692us
Time Slot Period/Frame Period	576.9us 4.615ms	576.9us 4.615ms	576.9us 4.615ms	576.9us 4.615ms
Modulation	0.3GMSK	0.3GMSK	0.3GMSK	0.3GMSK
MS Power	33dBm~13dBm	33dBm~5dBm	30dBm~0dBm	30dBm~0dBm
Power Class	5pcl ~ 15pcl	5pcl ~ 19pcl	0pcl ~ 15pcl	0pcl ~ 15pcl
Sensitivity	-102dBm	-102dBm	-100dBm	-100dBm
TDMA Mux	8	8	8	8
Cell Radius	35Km	35Km	2Km	-

**1-2. GSM TX power class**

<b>TX Power control level</b>	<b>GSM900</b>	<b>TX Power control level</b>	<b>DCS1800</b>	<b>TX Power control level</b>	<b>PCS1900</b>
5	33±2 dBm	0	30±3 dBm	0	30±3 dBm
6	31±2 dBm	1	28±3 dBm	1	28±3 dBm
7	29±2 dBm	2	26±3 dBm	2	26±3 dBm
8	27±2 dBm	3	24±3 dBm	3	24±3 dBm
9	25±2 dBm	4	22±3 dBm	4	22±3 dBm
10	23±2 dBm	5	20±3 dBm	5	20±3 dBm
11	21±2 dBm	6	18±3 dBm	6	18±3 dBm
12	19±2 dBm	7	16±3 dBm	7	16±3 dBm
13	17±2 dBm	8	14±3 dBm	8	14±3 dBm
14	15±2 dBm	9	12±4 dBm	9	12±4 dBm
15	13±2 dBm	10	10±4 dBm	10	10±4 dBm
16	11±3 dBm	11	8±4 dBm	11	8±4 dBm
17	9± 3dBm	12	6±4 dBm	12	6±4 dBm
18	7±3 dBm	13	4±4 dBm	13	4±4 dBm
19	5±3 dBm	14	2±5 dBm	14	2±5 dBm
		15	0±5 dBm	15	0±5 dBm

## 2. SGH-E880 Flow Chart of Troubleshooting

### 2-1.Baseband

#### 2-1-1. Power ON

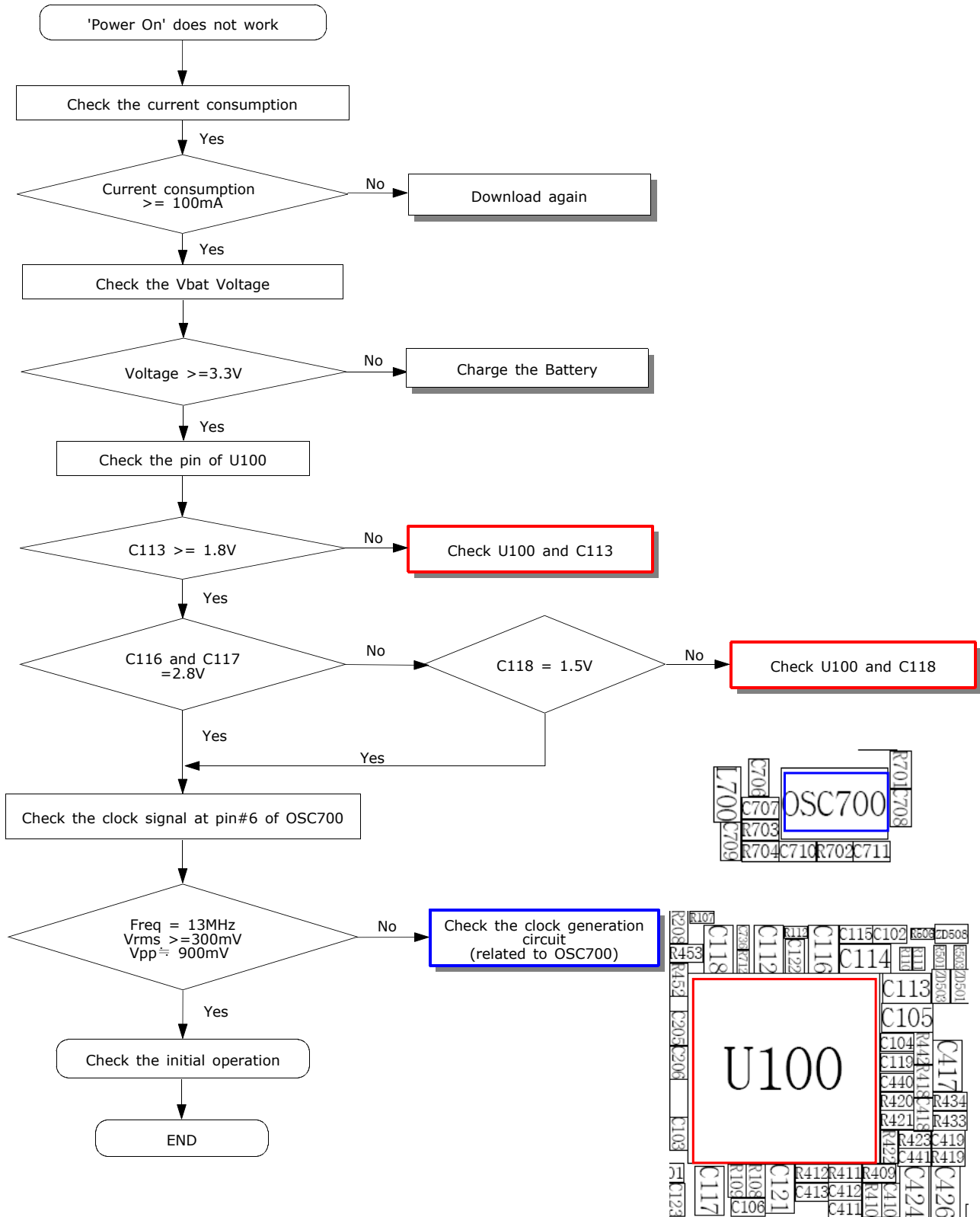

CSP2600

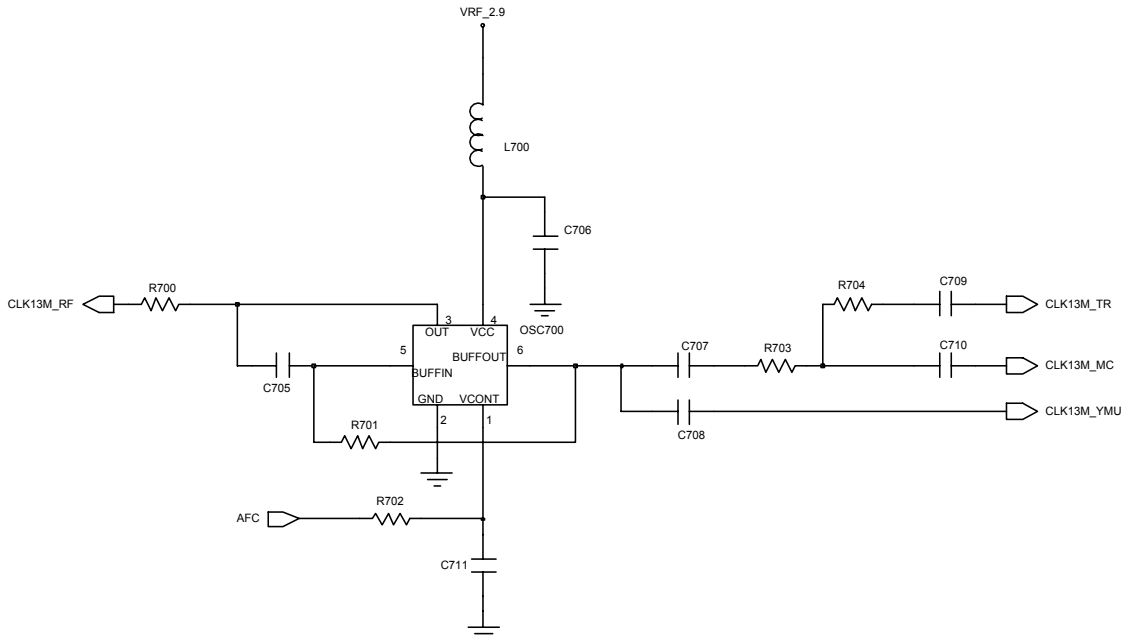
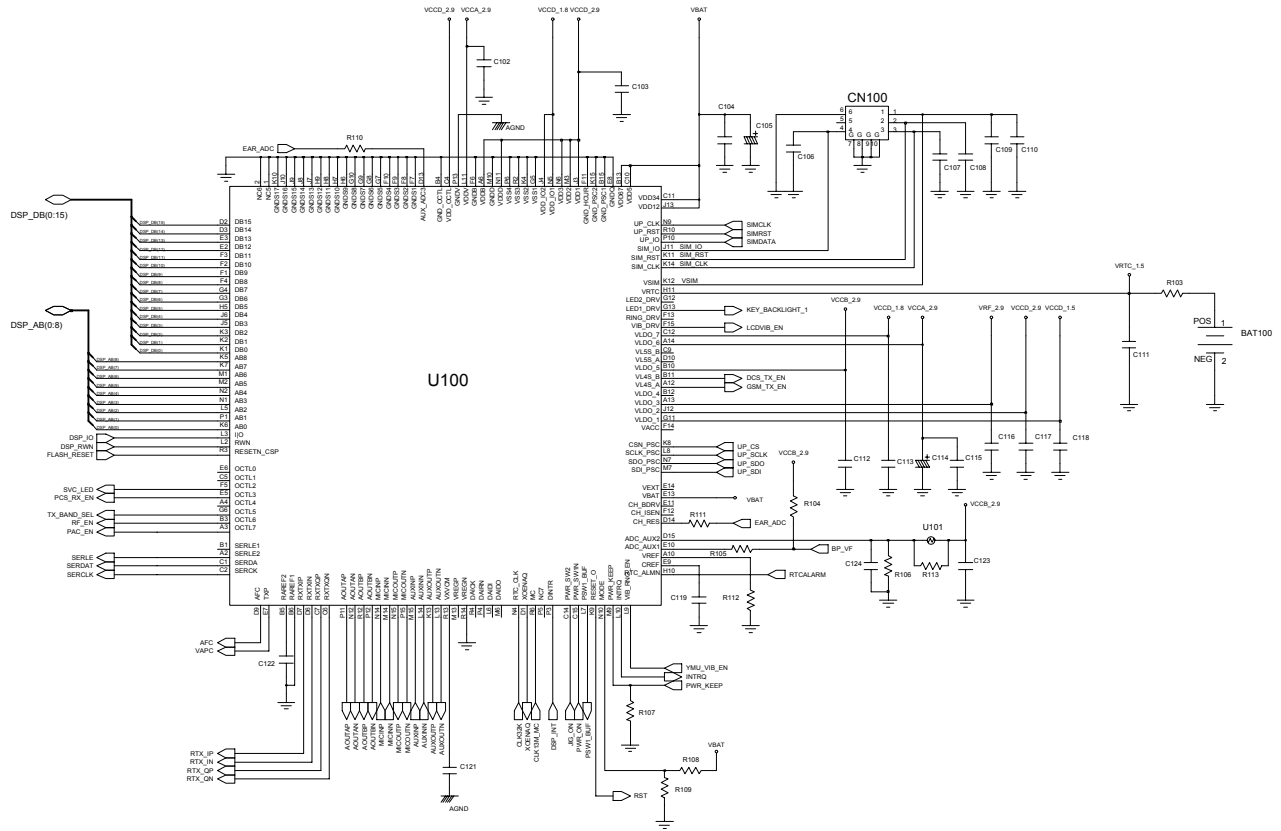

## 2-1-2. Initial

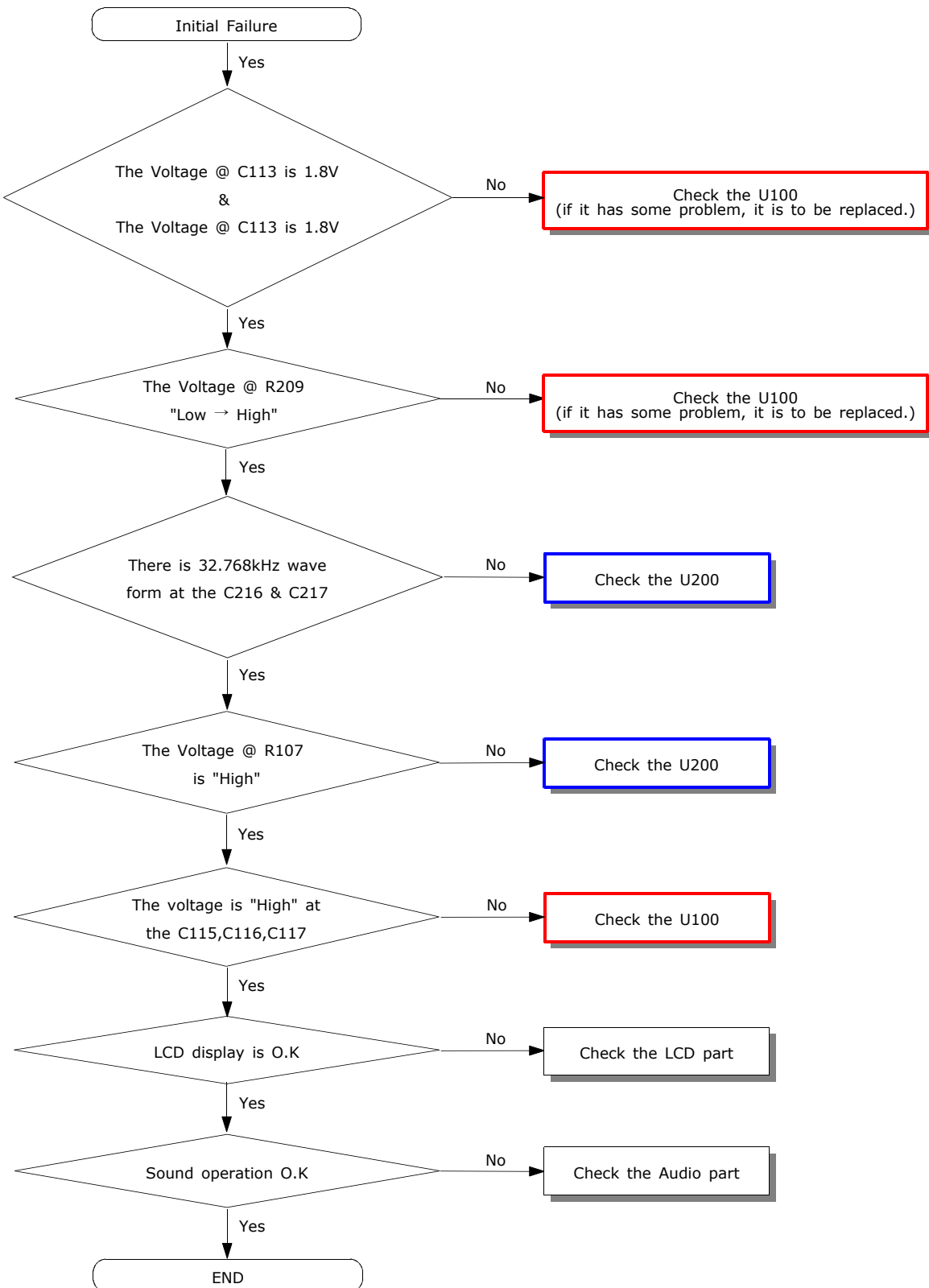

# SGH-E880 Flow Chart of Troubleshooting

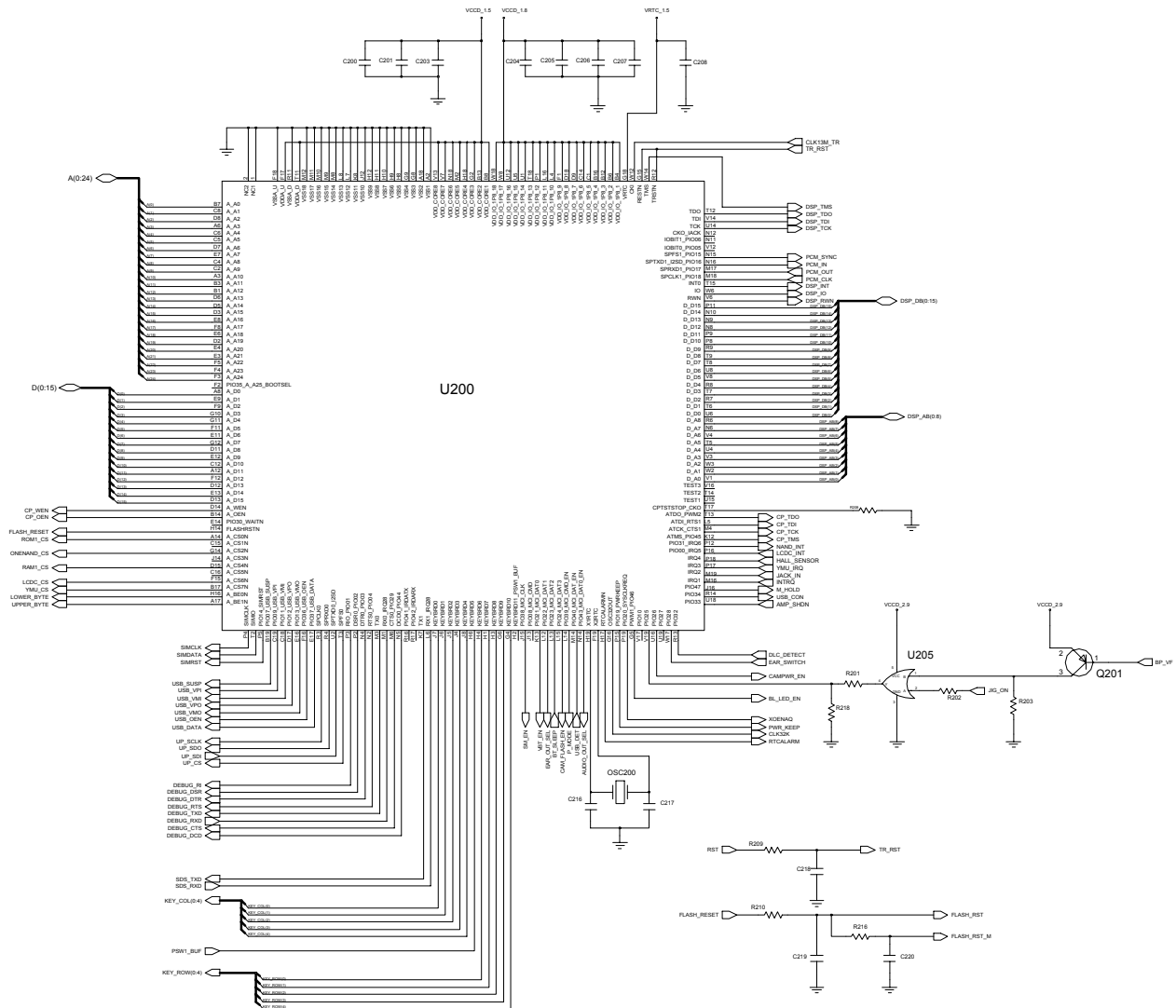
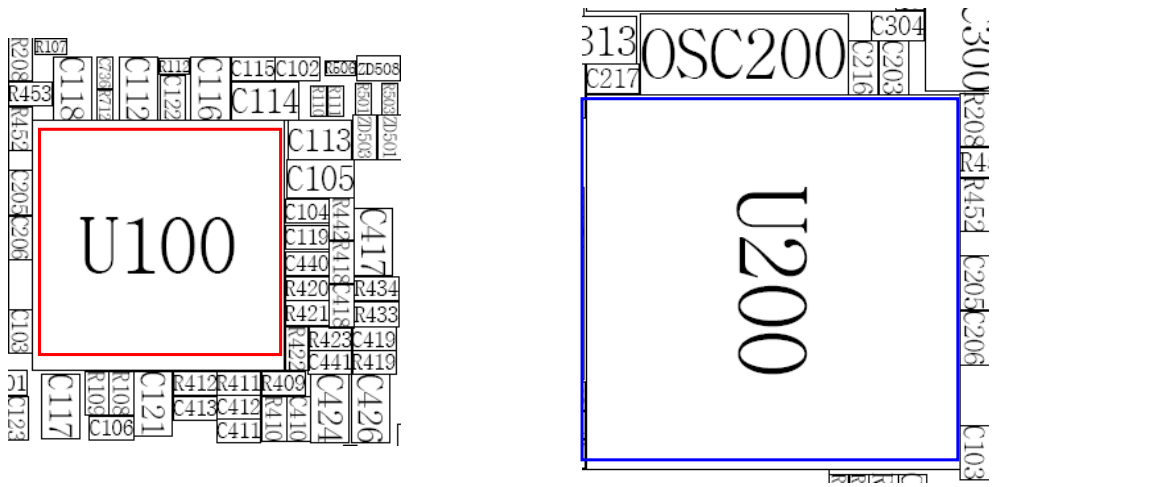

### 2-1-3. Sim Part

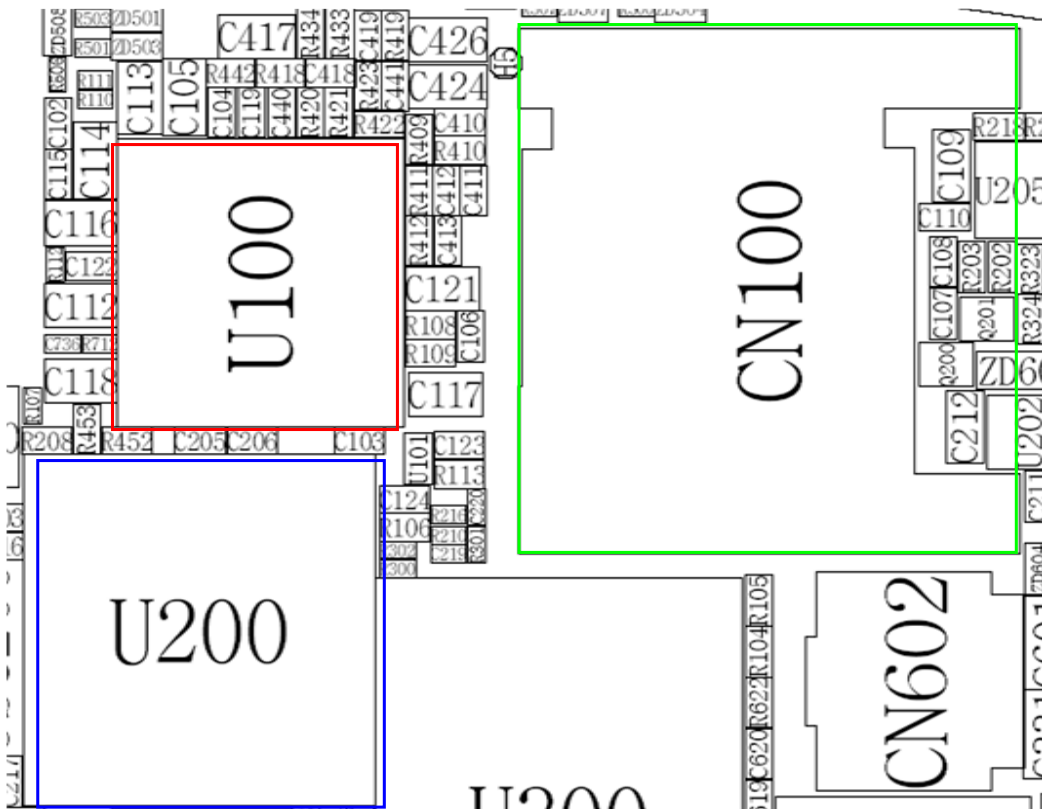
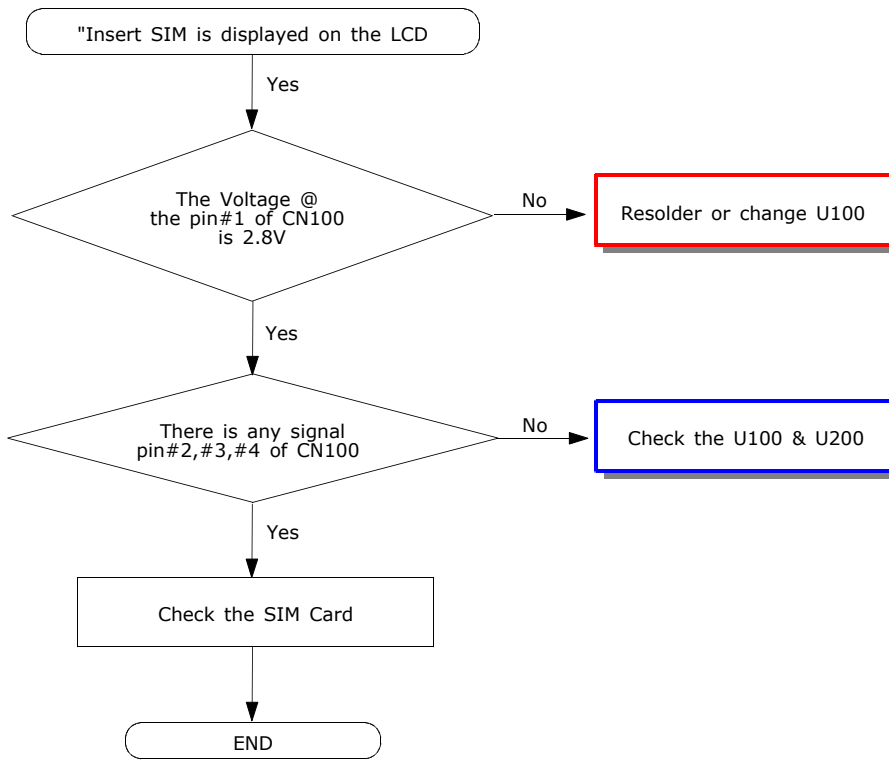



CSP2600 SIM PART

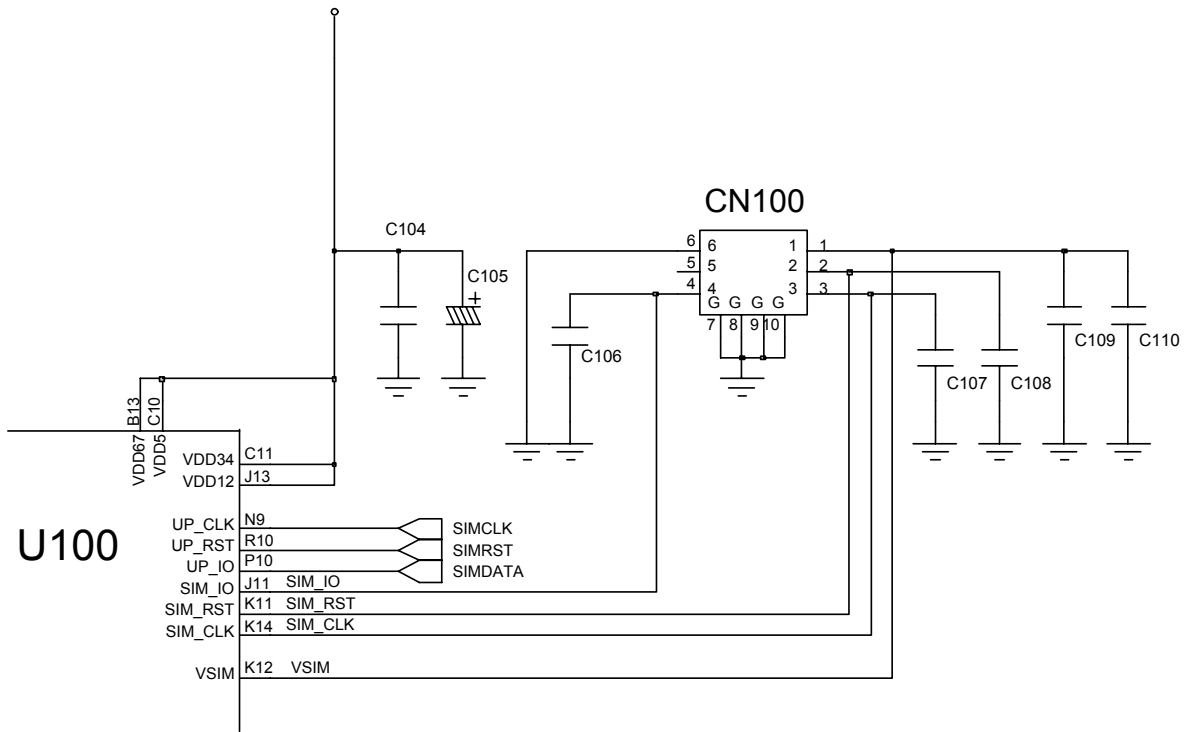

### 2-1-4. Microphone Part

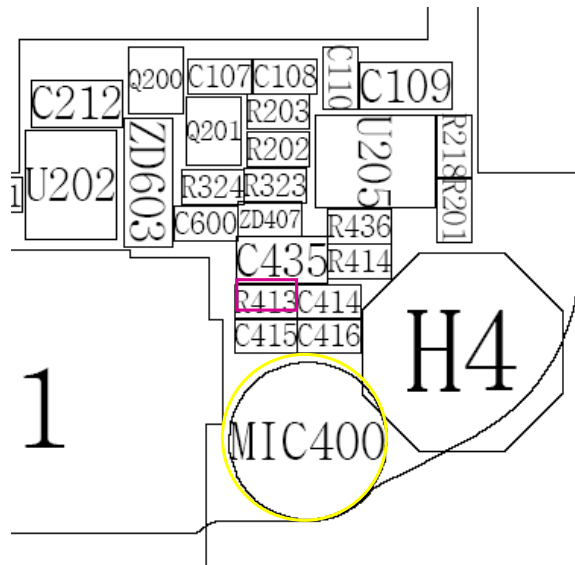
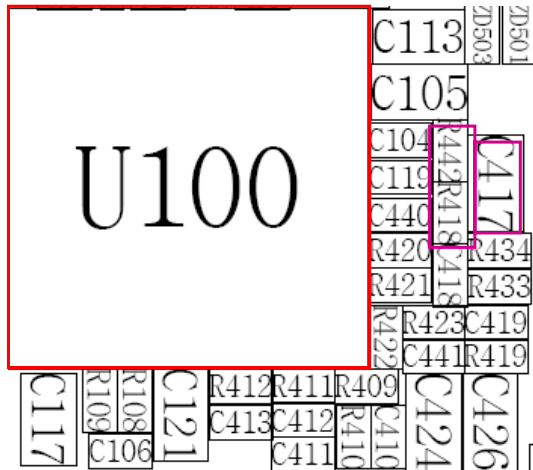
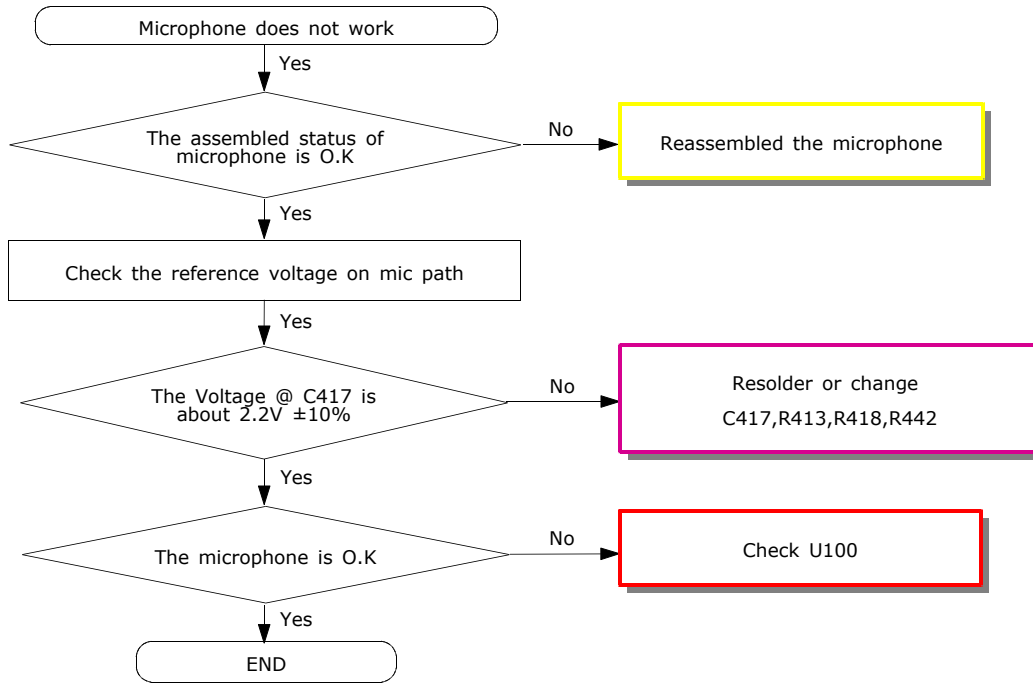

# MICROPHONE PART

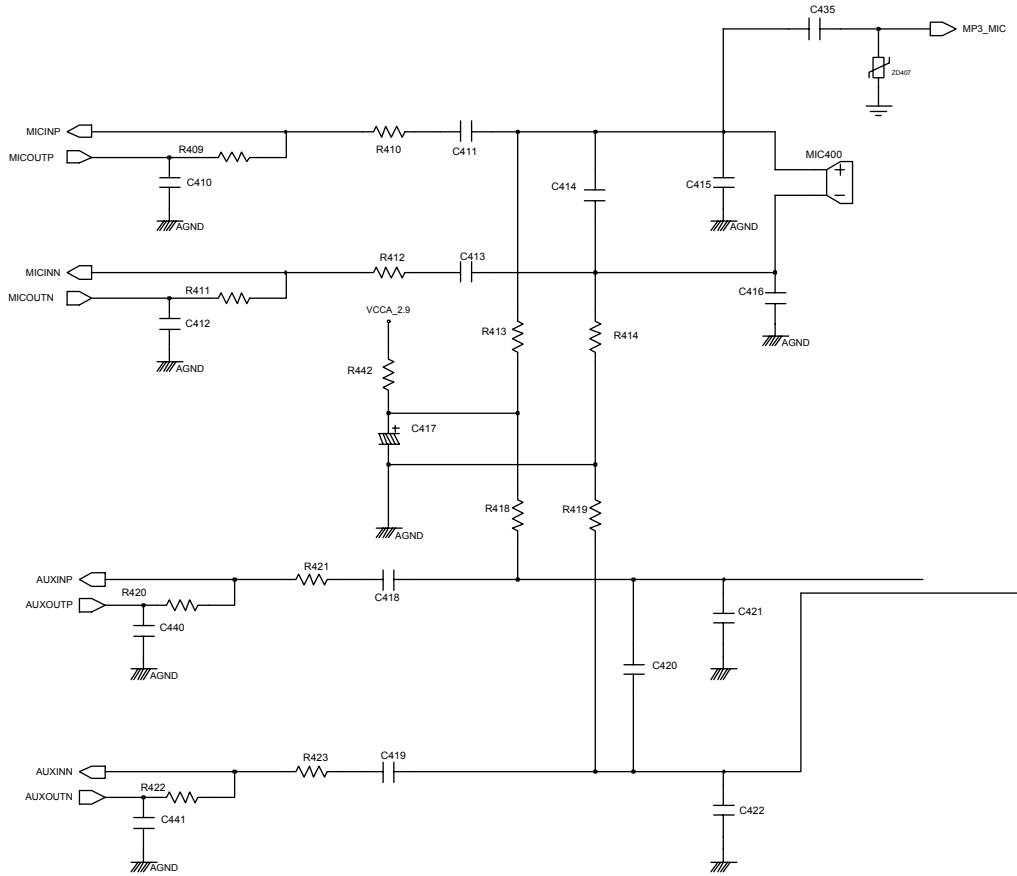

## U100

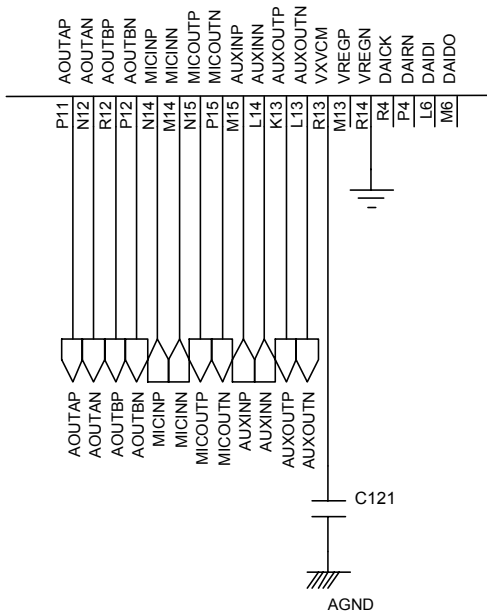

## CSP2600 AUDIO PART

### 2-1-5. Speaker Part

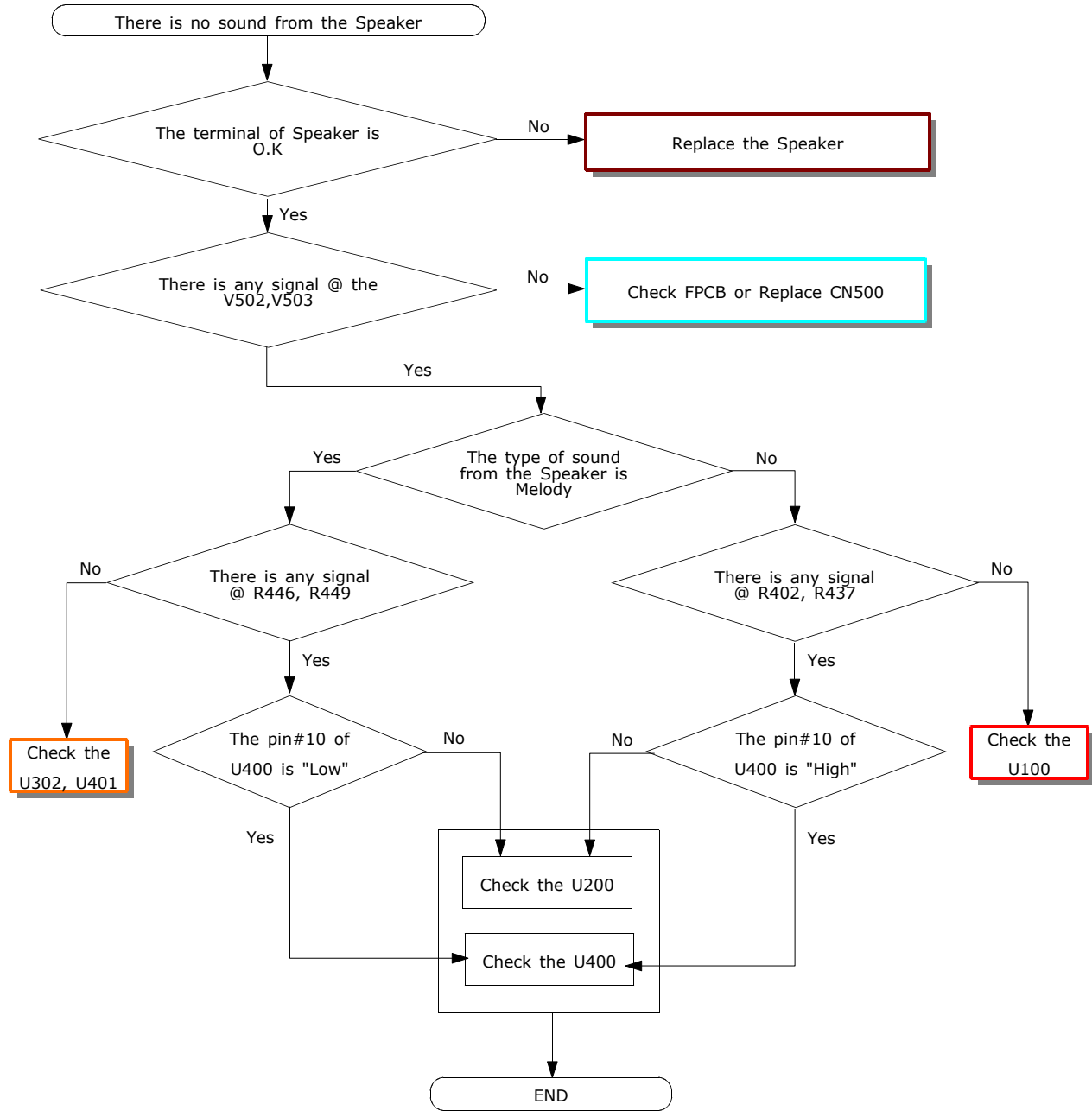

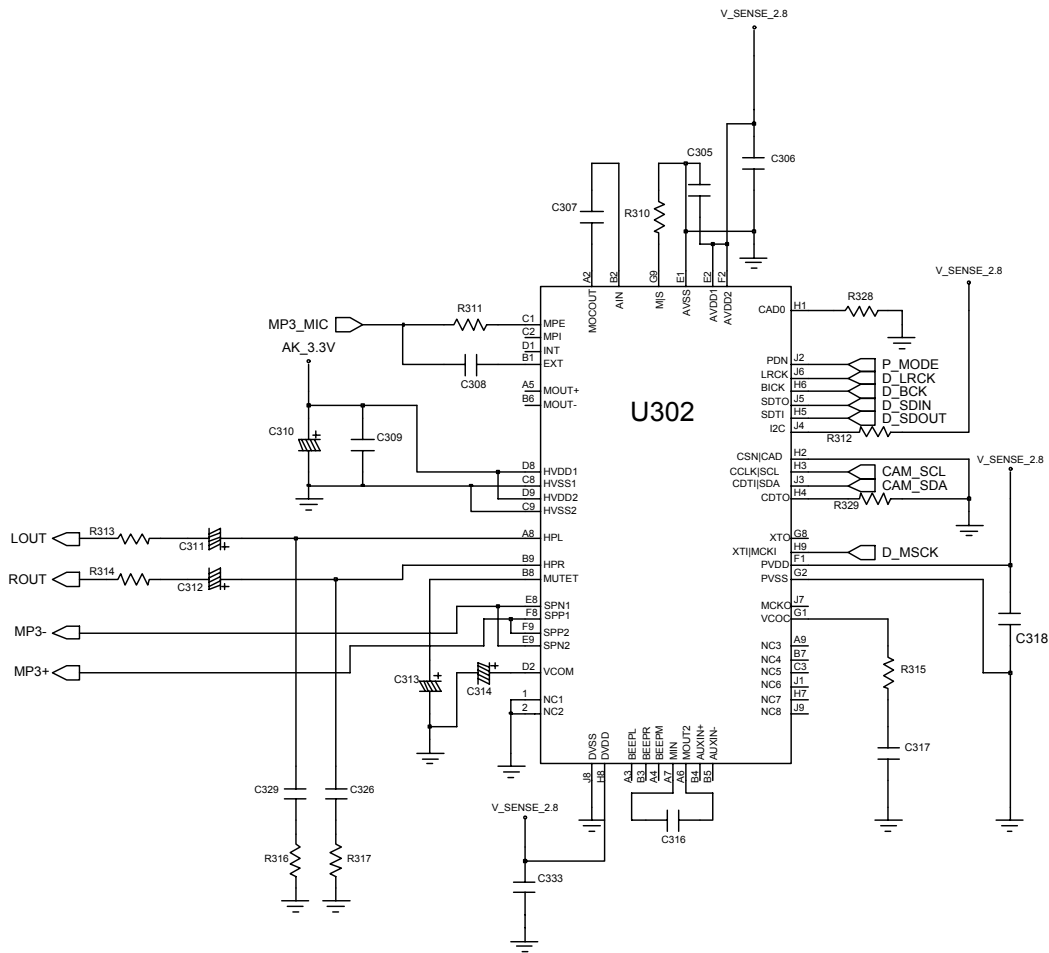
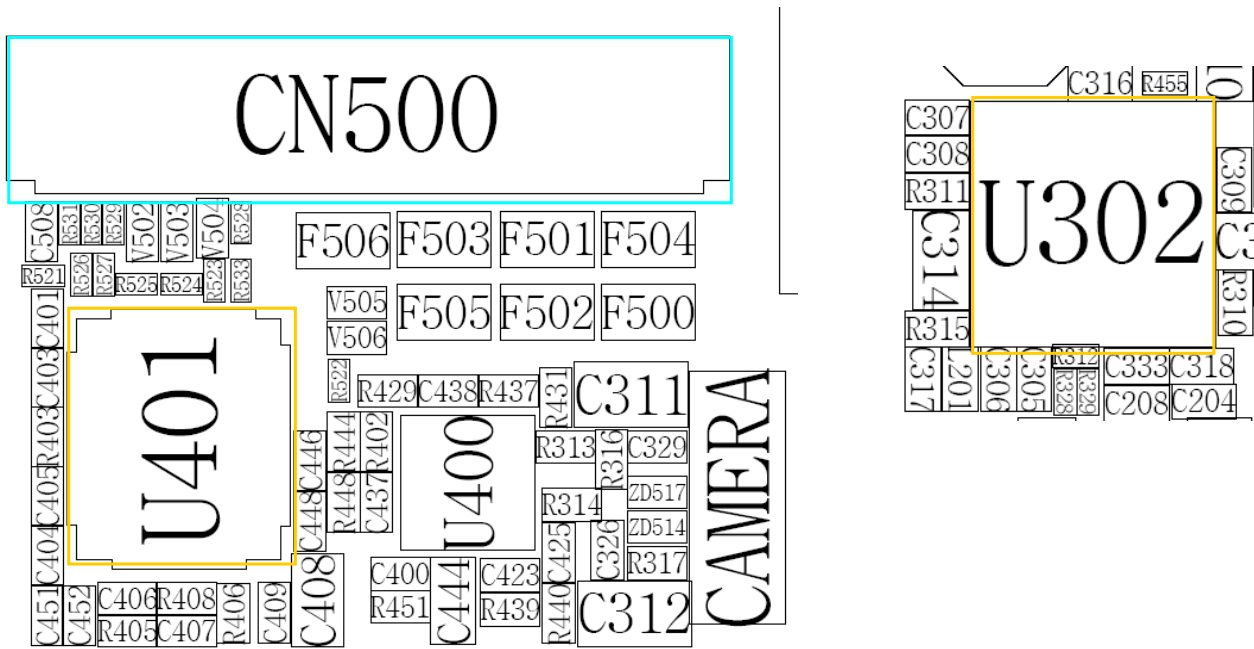

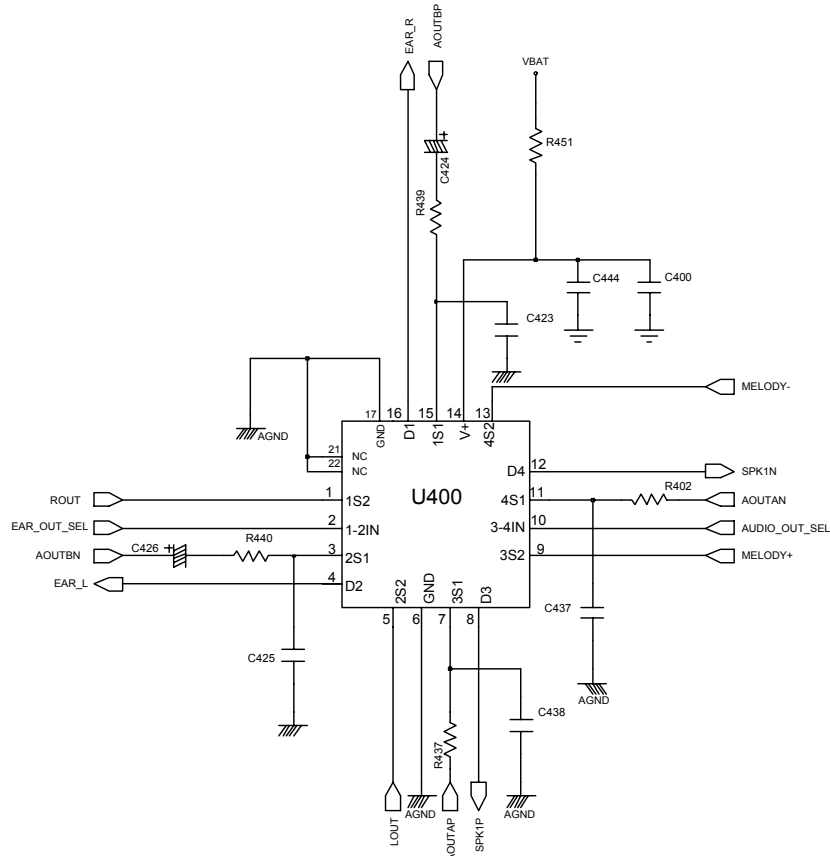

melody generator

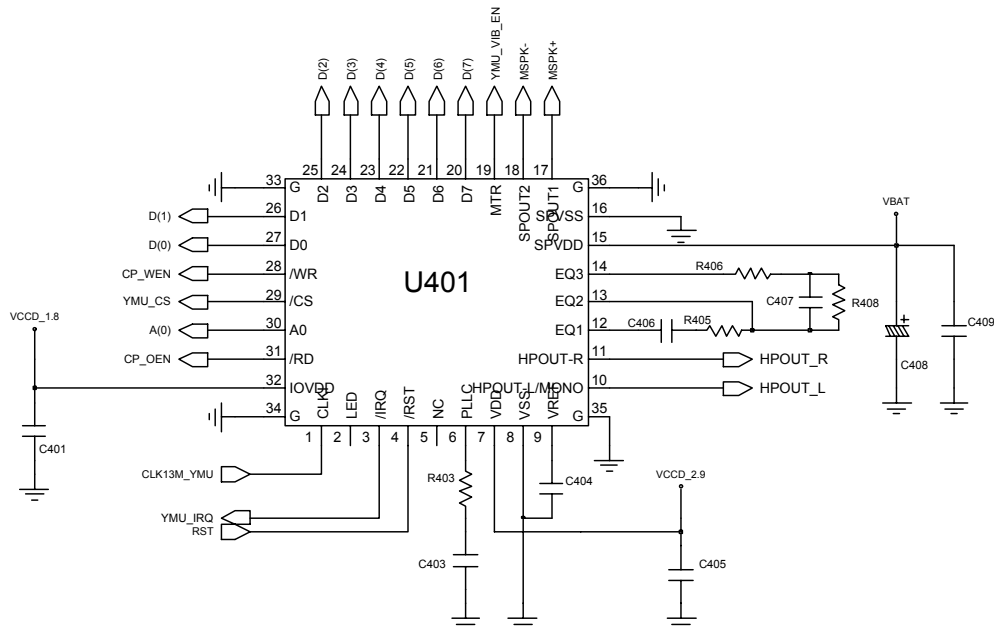

### 2-1-6. Camera Part

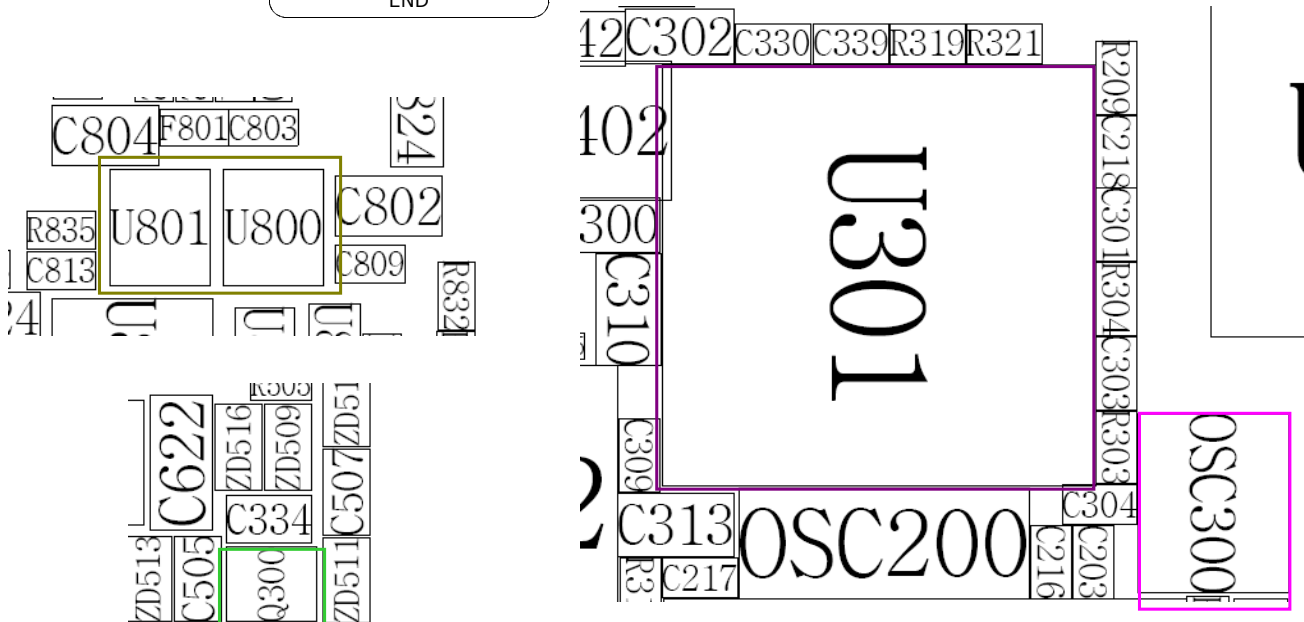
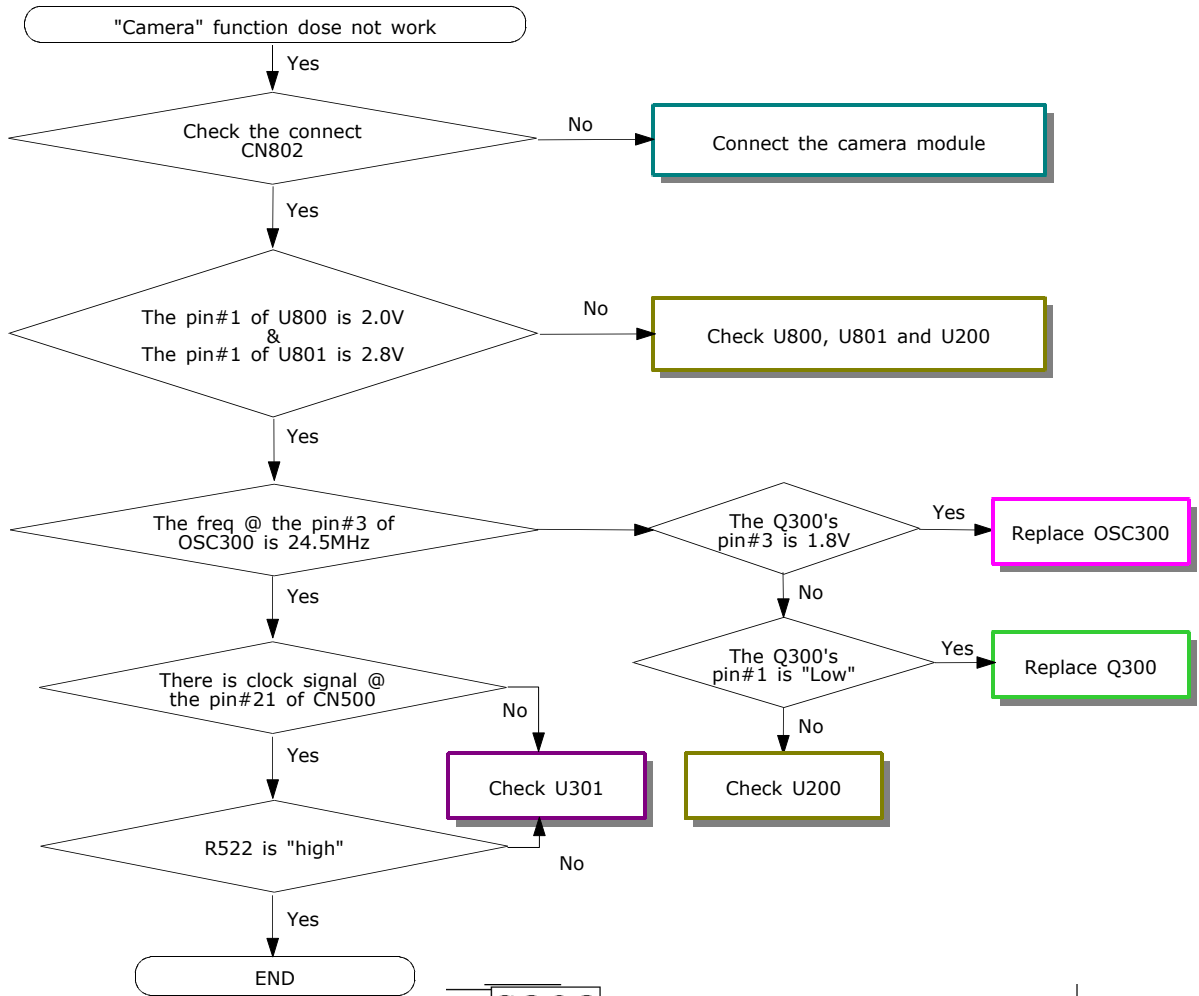

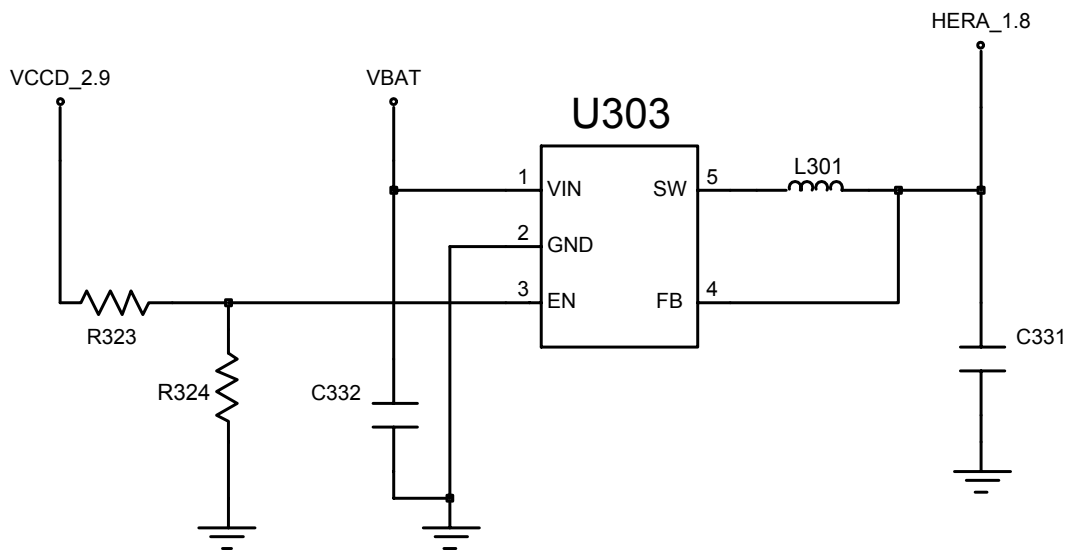
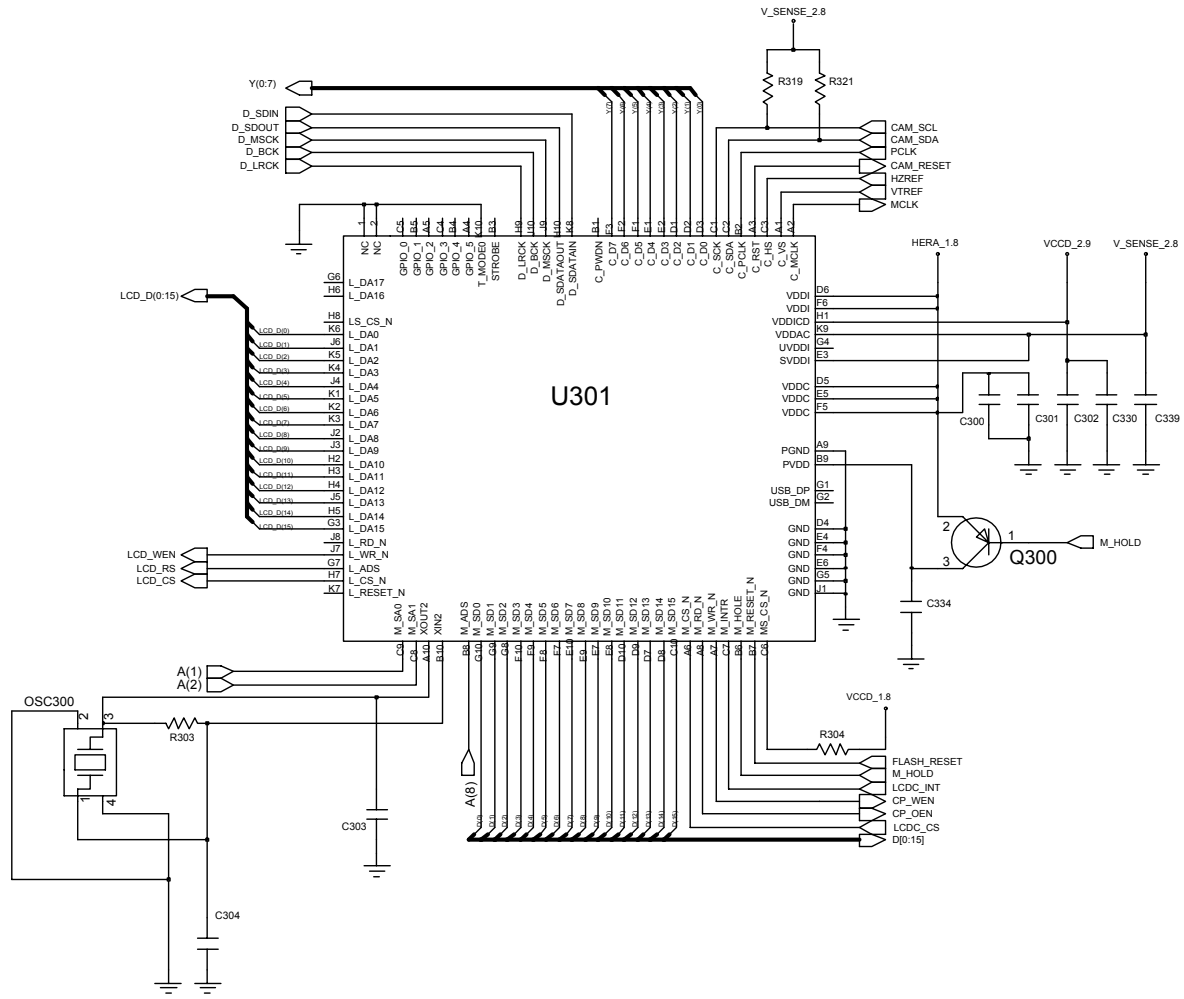





## 2-2.RF

### 2-2-1. EGSM RX

CONTINUOUS RX ON  
RF INPUT : 62CH  
AMP : -50dBm

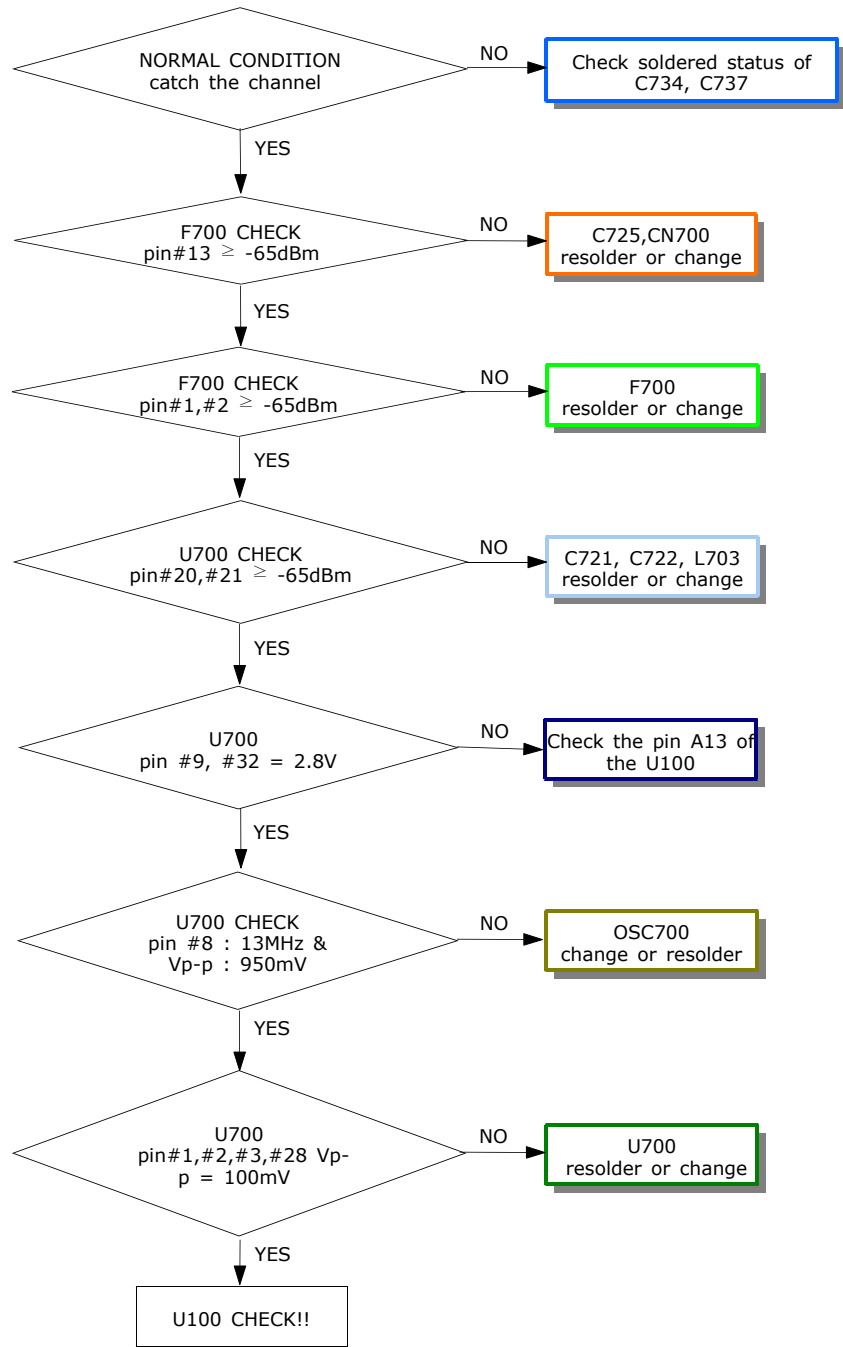

2-2-2. DCS RX

CONTINUOUS RX ON  
 RF INPUT : 660CH  
 AMP : -50dBm

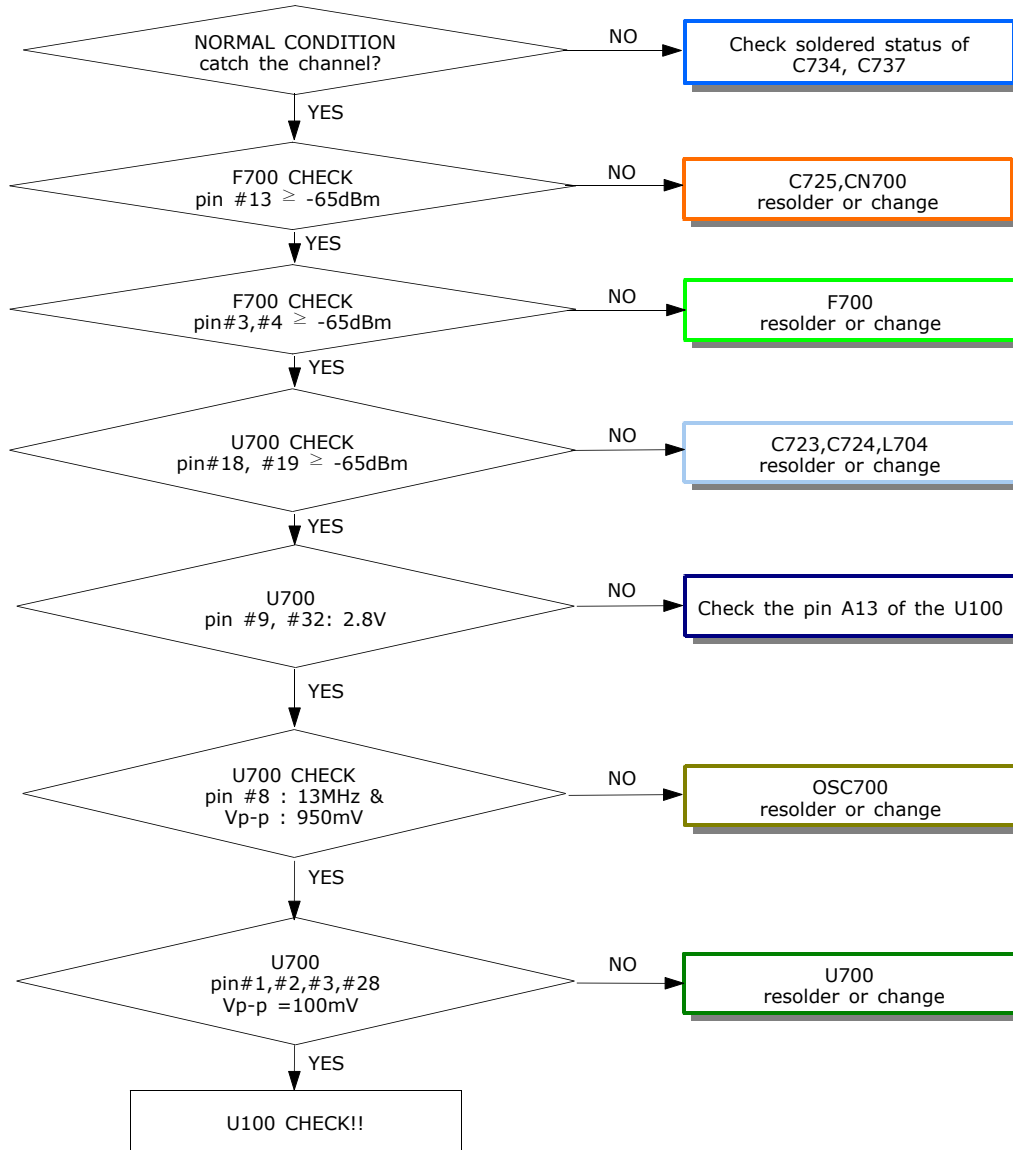

2-2-3. PCS RX

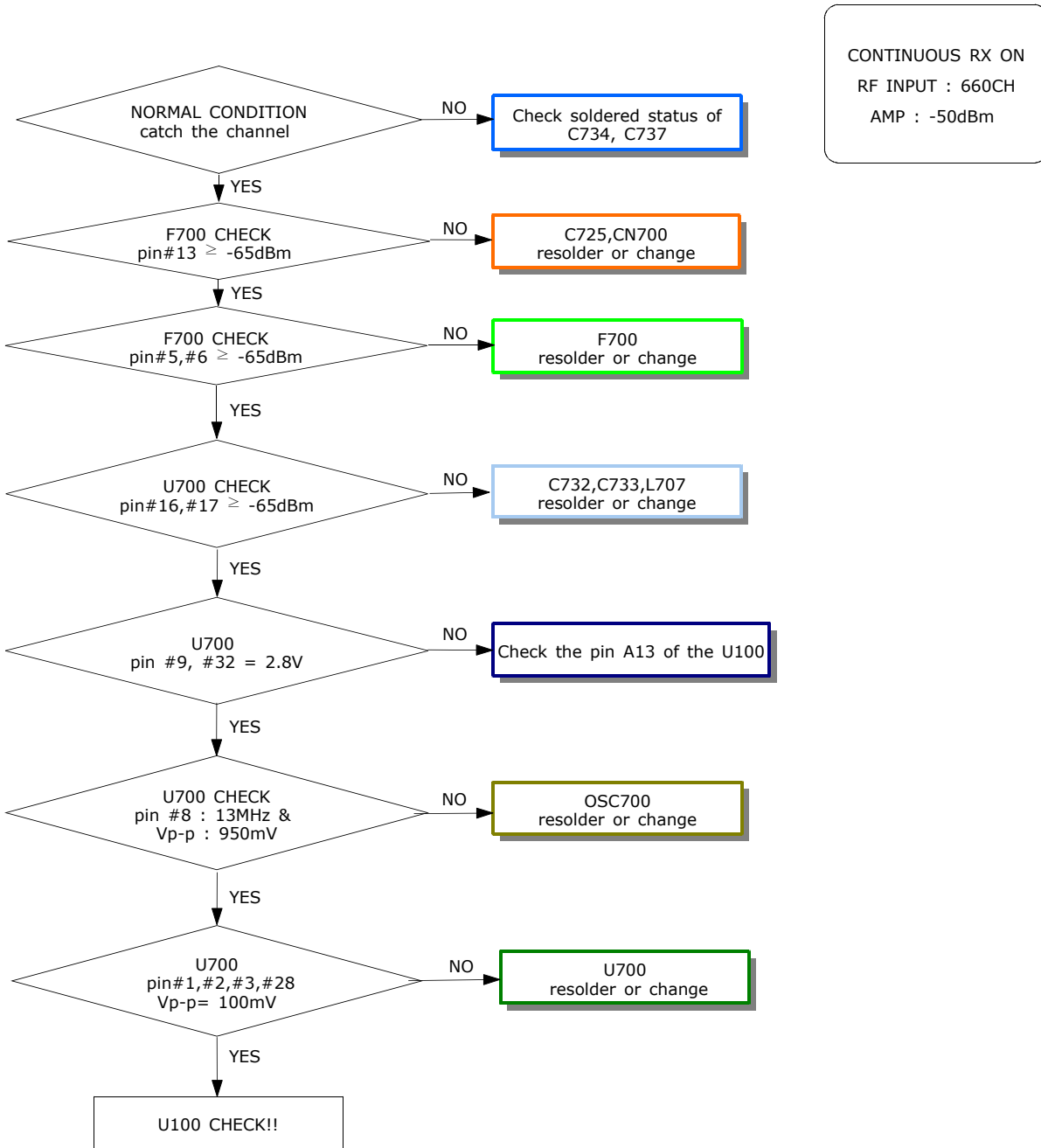

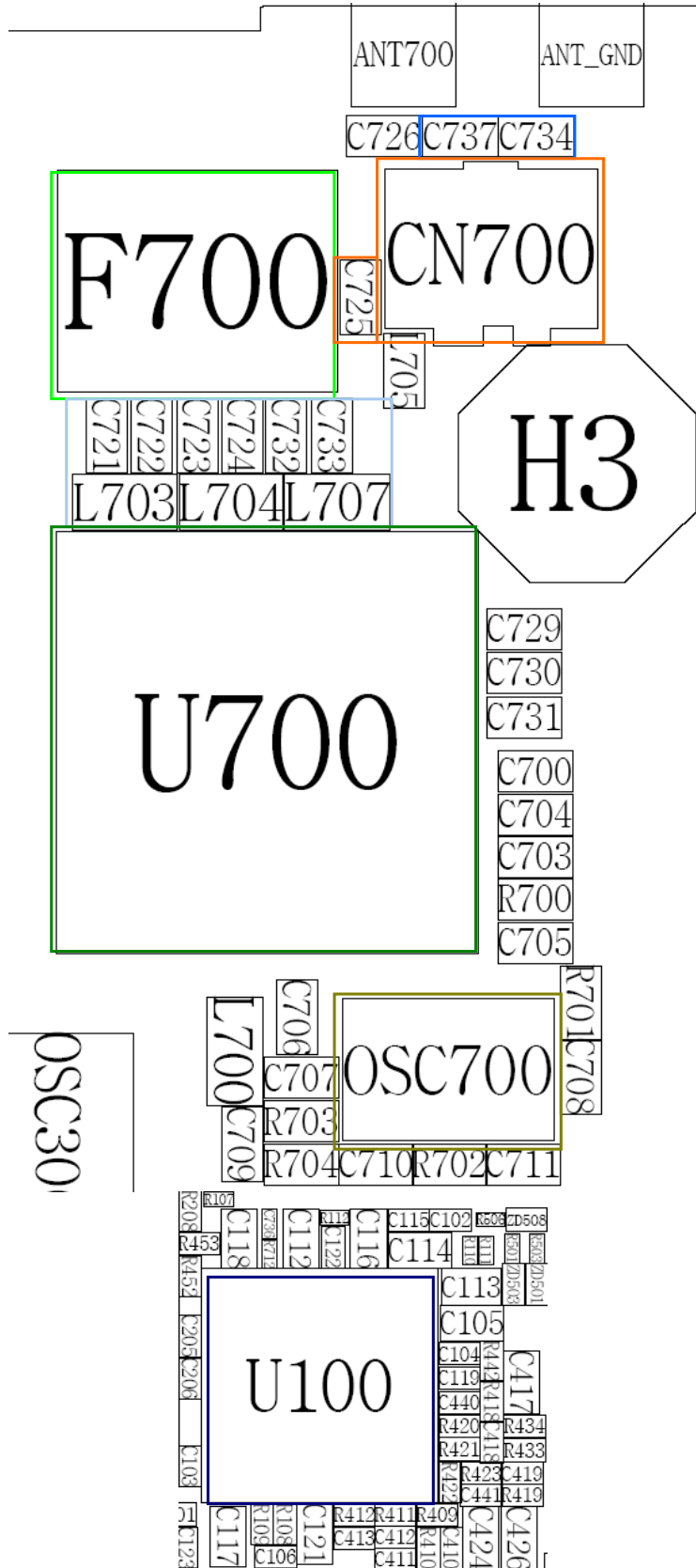

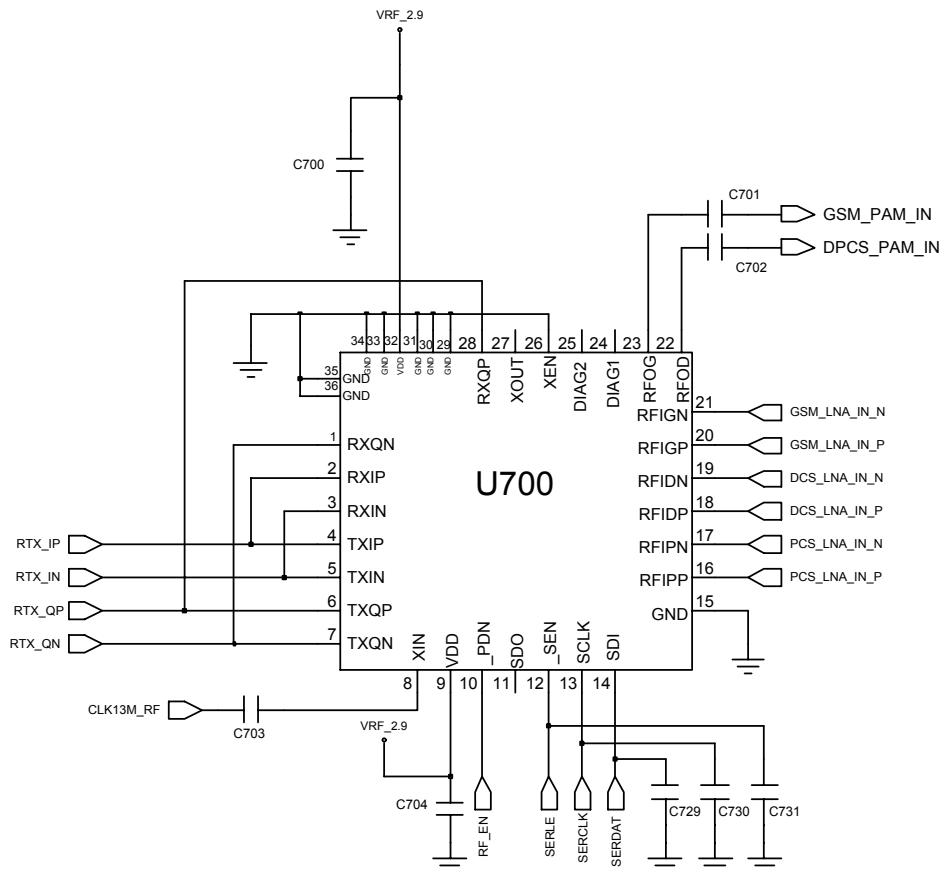
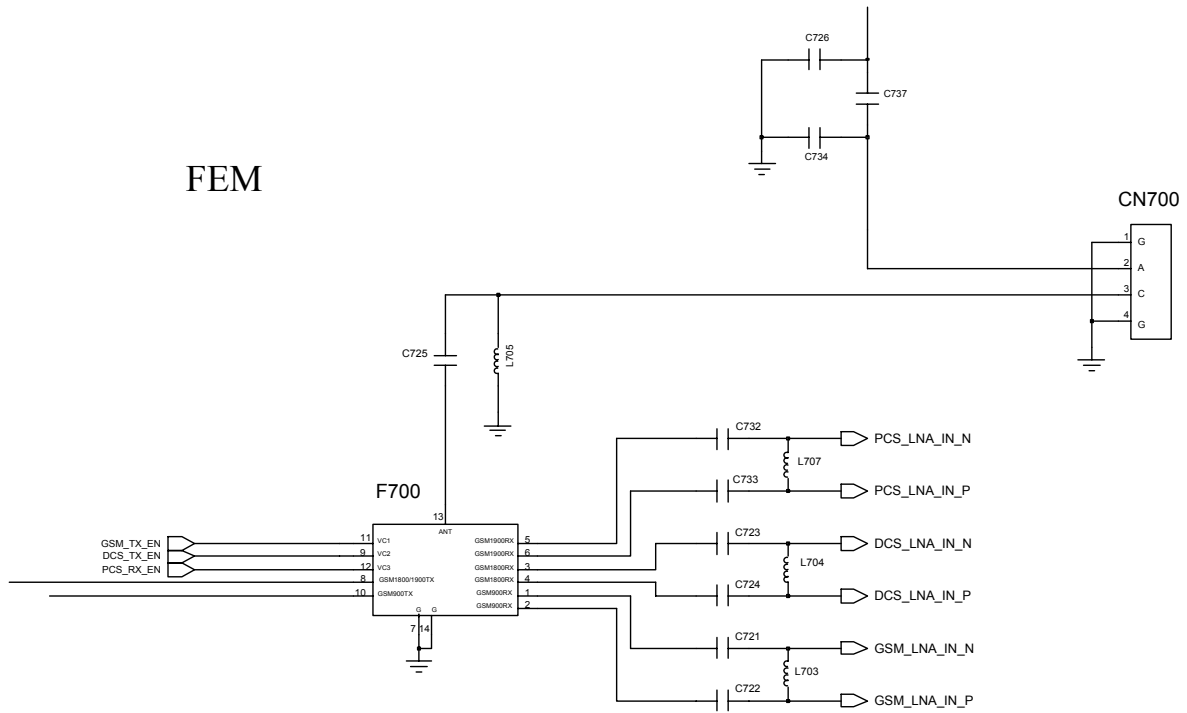

2-2-4. EGSM TX

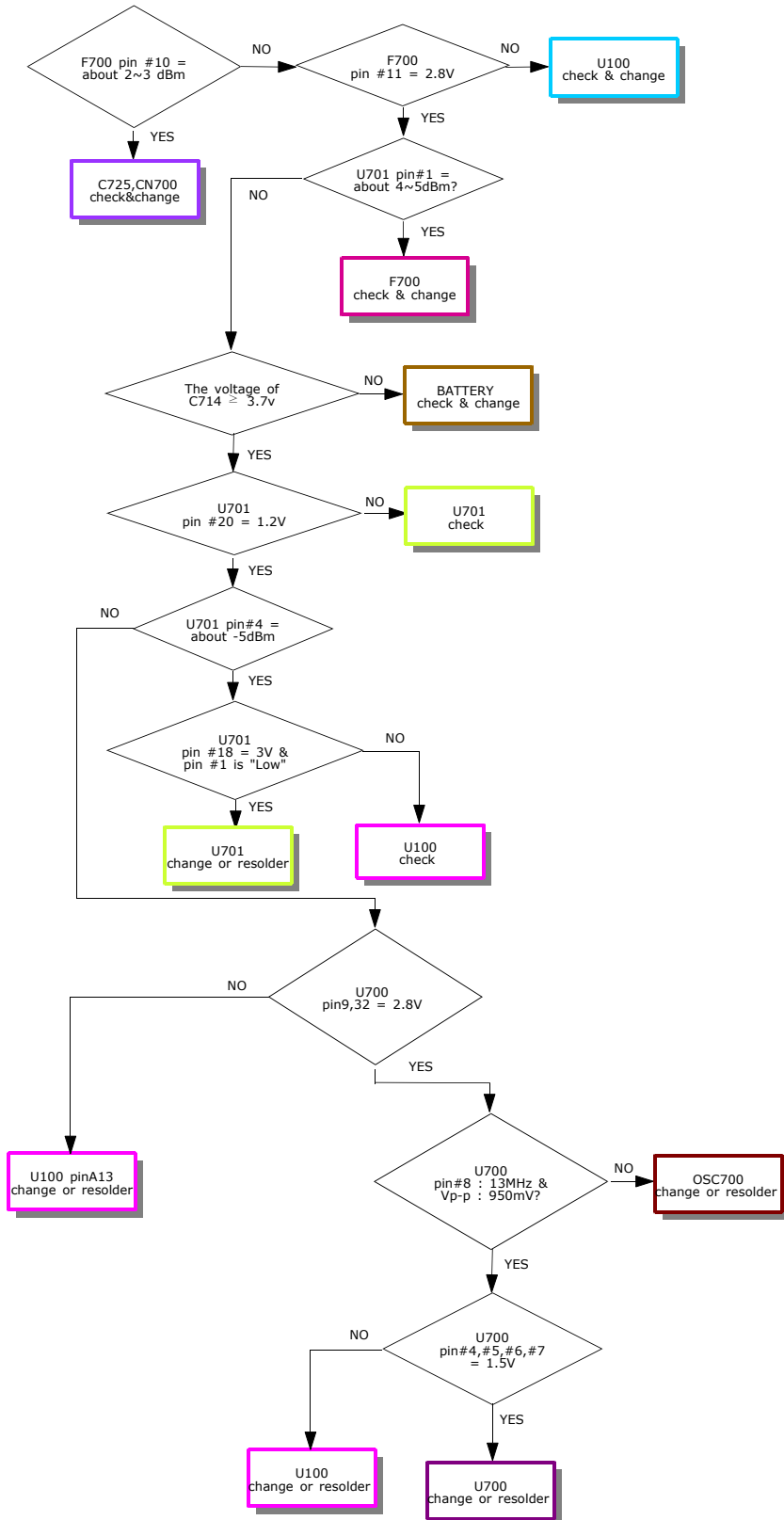

CONTINUOUS TX ON CONDITION  
 TX POWER DAC: 500 CODE APPLIED  
 CH : 30  
 RBW : 100KHz  
 VBW : 100KHz  
 SPAN : 10MHz  
 REF LEV. : 10dBm  
 ATT. : 20dB

2-2-5. DCS TX

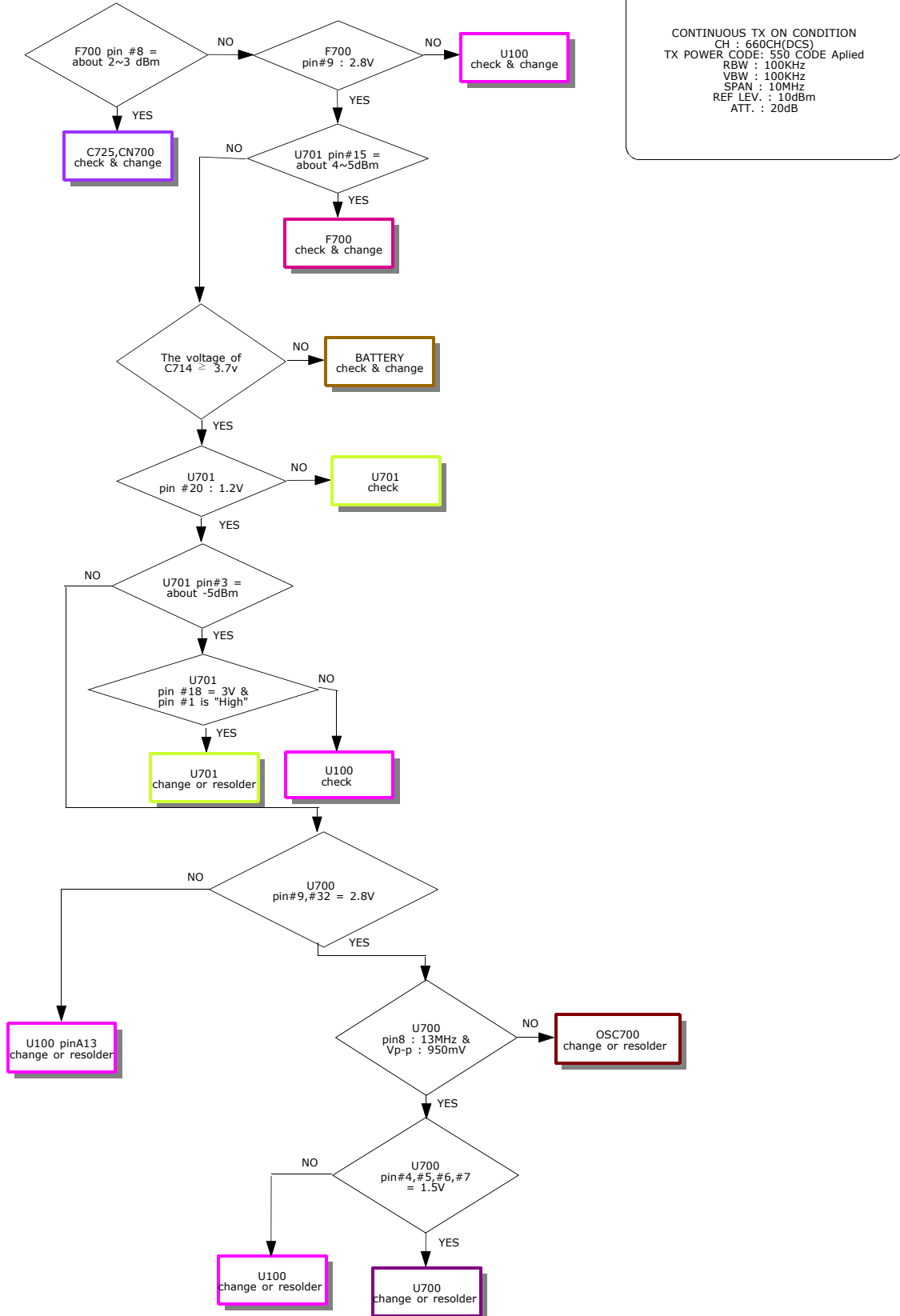

CONTINUOUS TX ON CONDITION  
 CH : 660CH(DCS)  
 TX POWER CODE: 550 CODE Applied  
 RBW : 100KHz  
 VBW : 100KHz  
 SPAN : 10MHz  
 REF LEV. : 10dBm  
 ATT. : 20dB



2-2-6. PCS TX

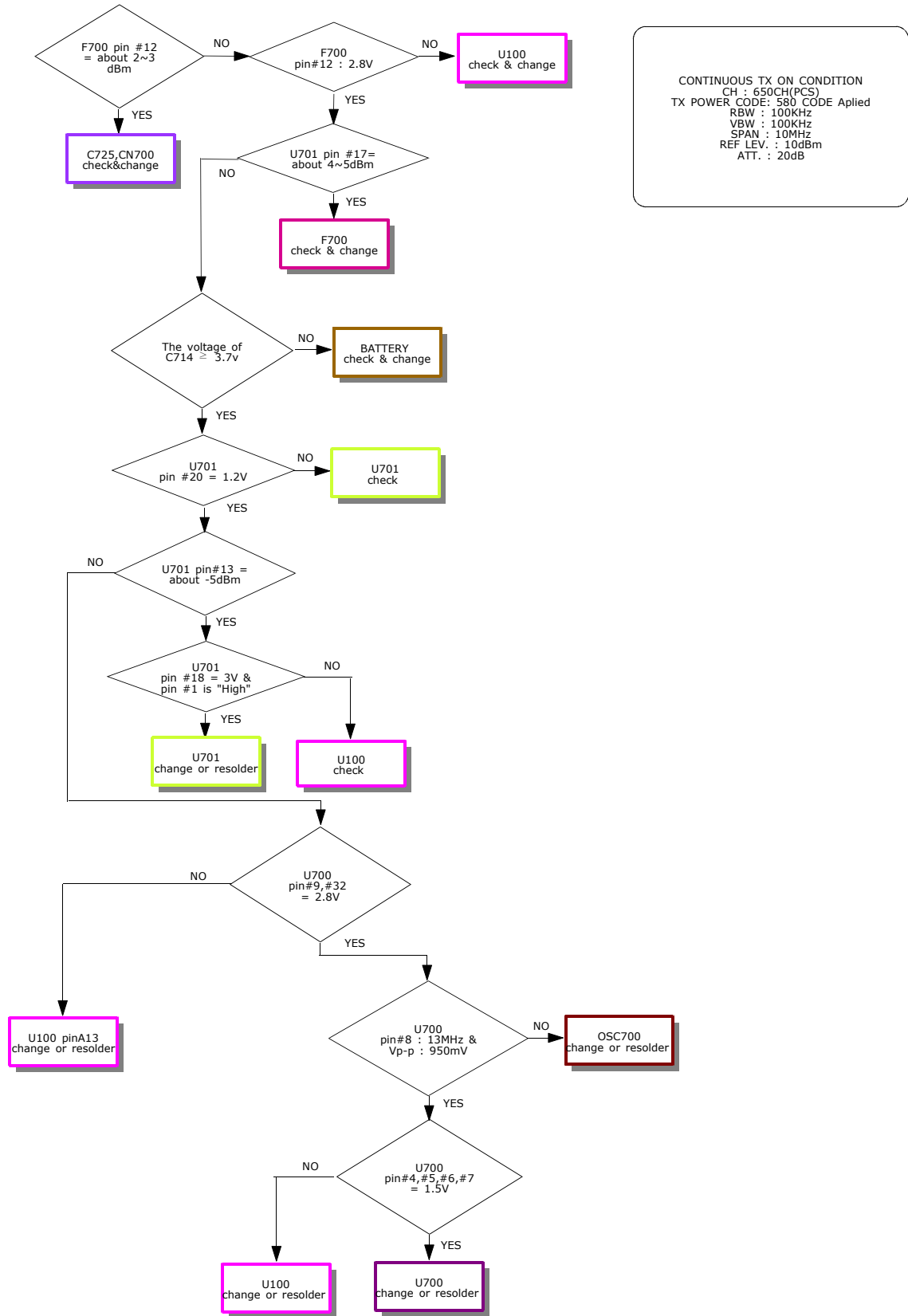

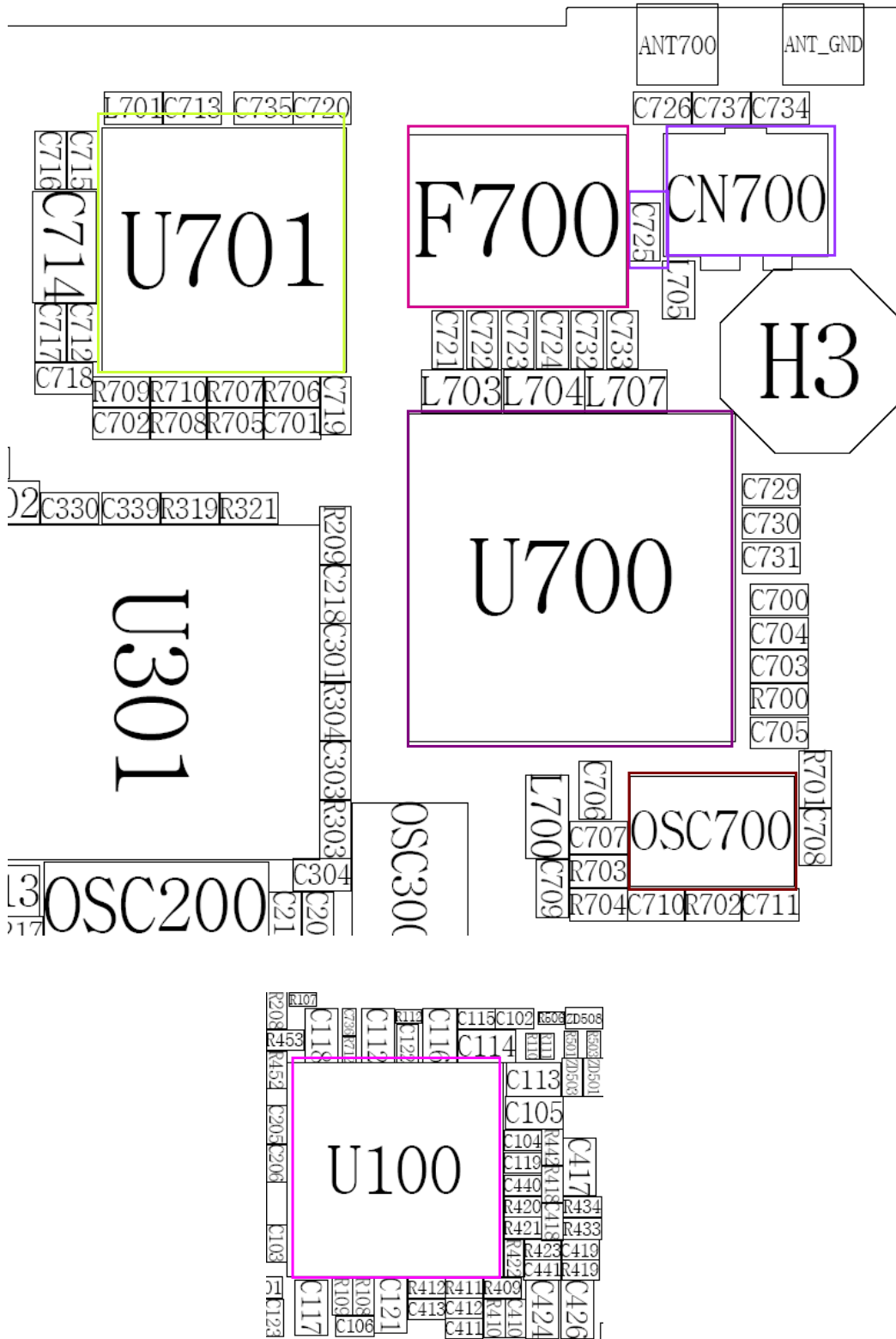

### PAM

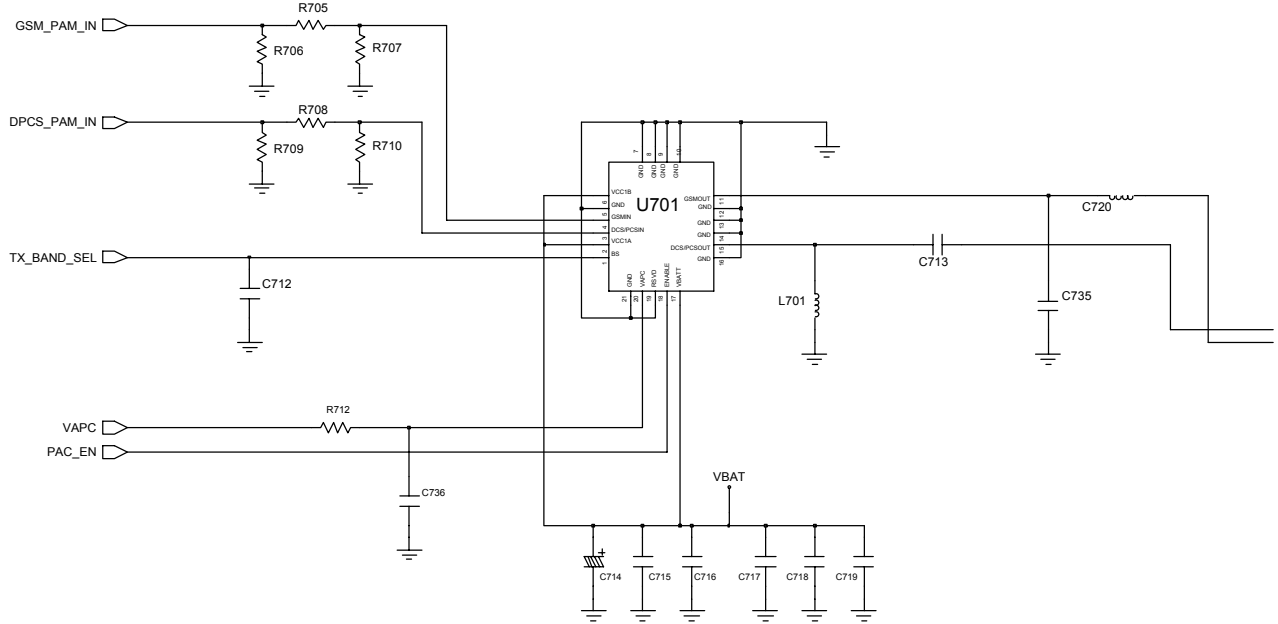

### FEM(Front-End Module)

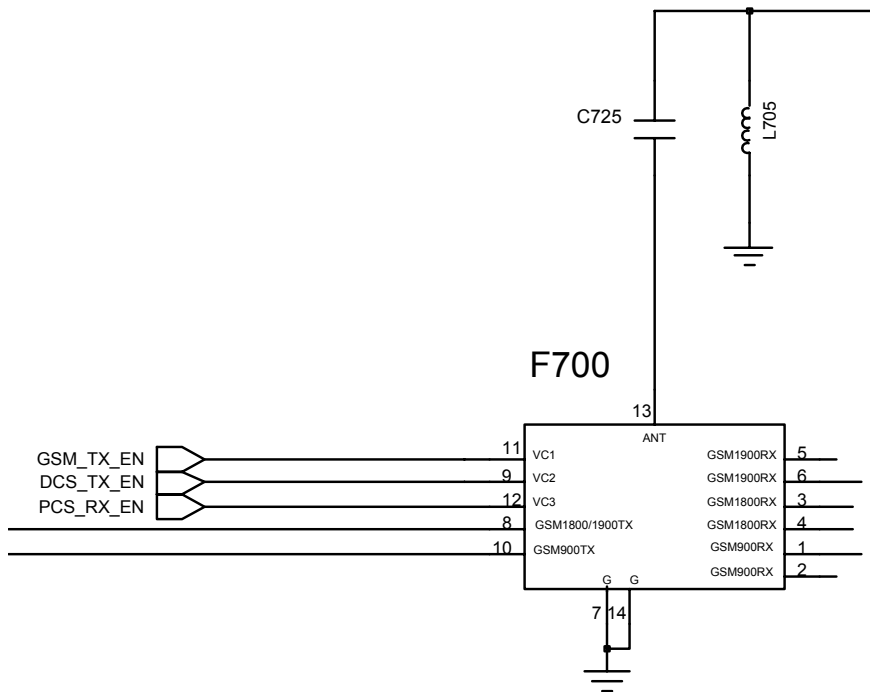

# 3. SGH-E880 Exploded View and Parts List

## 3-1. Cellular phone Exploded View

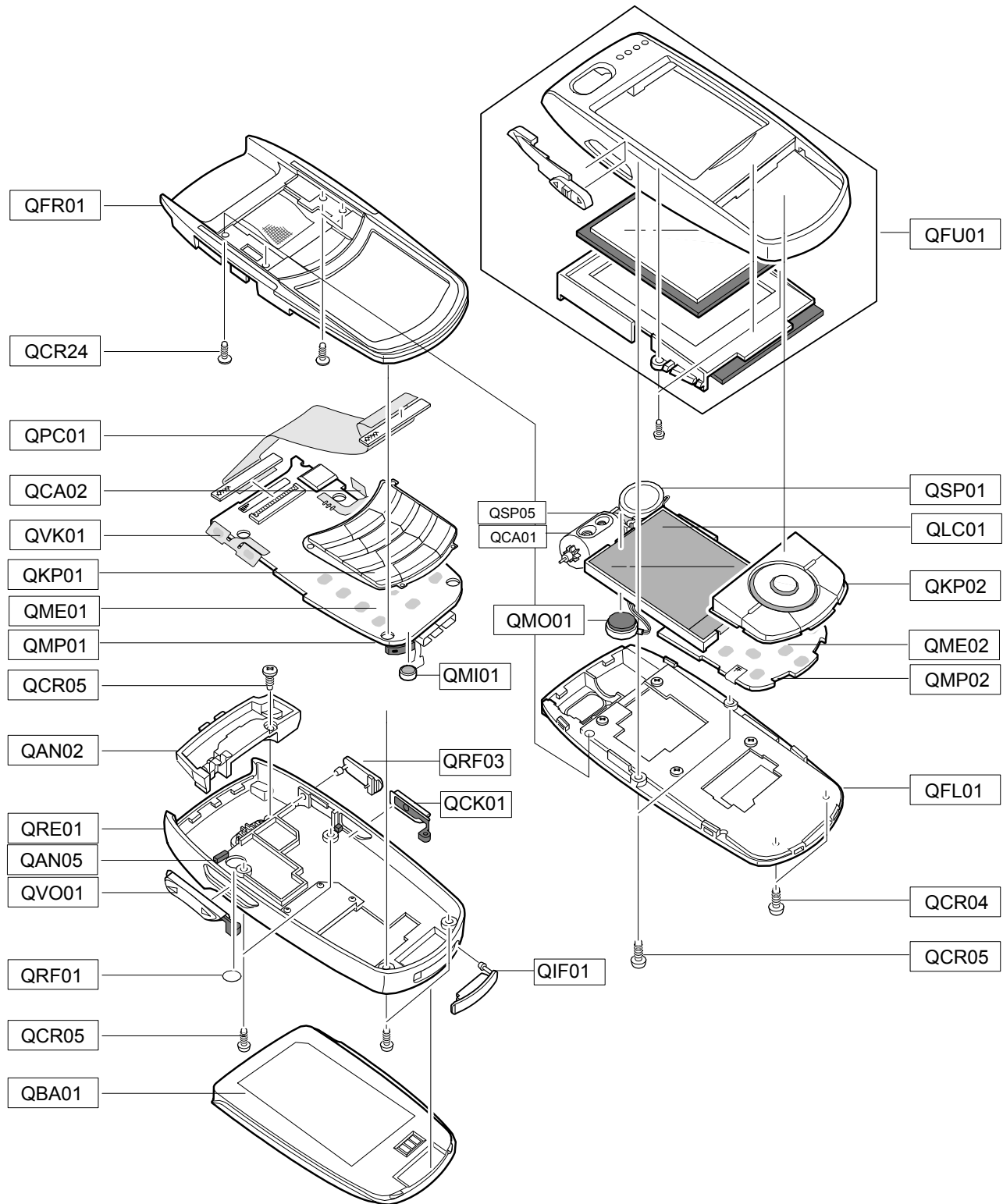

### 3-2. Cellular phone Parts list

Location NO.	Description	SEC CODE
QCR05	SCREW-MACHINE;PH,+,M1.4,L3,ZPC(BLK),	6001-001478
QBA01	BATTERY-800MAH,M/BLACK,ENG,M;BST4478	GH43-01742A
QRF01	MPR-TAPE RF HOLE CAP;SGH-E880,PC SHE	GH74-13316A
QMP01	PBA MAIN-SGHE880;SGH-E880,XET,ITAY,-	GH92-01992A
QMI01	MICROPHONE-ASSY;2,130~500uA,-42dB,2.	GH30-00180A
QME01	UNIT-METAL DOME;SGH-E880,SGH-E880 F/	GH59-01888A
QVK01	UNIT-VOLUME KEY;SGH-E880,SPH-E880 V/	GH59-01894A
QCA02	UNIT-CAM KEY;SGH-E880,SPH-E880 C/K,-	GH59-01895A
QSP01	SPEAKER;0.7W,8ohm,88dB±2dB,850Hz,13	3001-001775
QCR05	SCREW-MACHINE;PH,+,M1.4,L3,ZPC(BLK),	6001-001478
QCR04	SCREW-MACHINE;PH,+,M1.4,L4,NYLOK,SWR	6001-001479
QCR24	SCREW-MACHINE;CH,+,-,M1.4,L2,ZPC(BLK	6001-001892
QLC01	LCD-SCHS140 LCD;LTS170QC-F01,SCH-S14	GH07-00559A
QMO01	MOTOR DC;DMJBRK20NT,SGH-E880,90mA,-,	GH31-00138A
QPC01	PCB-SGHE880,FPCB;SGH-E880,POLYIMIDE,	GH41-00752A
QCA01	UNIT-CAMERA;SGH-E880,IC03035AA,-,GER	GH59-01902A
QSP05	MEC-SPK-MOT-HOLDER-ASSY;SGH-E880,ITA	GH75-06862A
QFR01	MEC-FRONT COVER SUB;SGH-E880,ITALY,-	GH75-06873A
QFL01	MEC-SLIDE LOWER SUB;SGH-E880,ITALY,-	GH75-06874A
QCR24	SCREW-MACHINE;CH,+,-,M1.4,L2,ZPC(BLK	6001-001892
QFU01	MEC-SLIDE UPPER SUB;SGH-E880,ITALY,-	GH75-06875A
QKP01	MEC-KEYPAD MAIN;SGH-E880,ITALY,-,-,B	GH75-06880A
QKP02	MEC-KEYPAD SUB;SGH-E880,ITAY,ABS,-,B	GH75-06892A
QMP02	PBA MAIN-SGHE880 LCD;SGH-E880,XET,IT	GH92-01998A
QME02	UNIT-NAVIGATION KEY;SGH-E880,SPH-E88	GH59-01893A
QCR05	SCREW-MACHINE;PH,+,M1.4,L3,ZPC(BLK),	6001-001478
QAN02	ANTENNA-SGHE880;SGH-E880,SGH-E880,88	GH42-00518A
QAN05	RMO-ANTENNA RUBBER;SGH-E880,CR RUBBE	GH73-04794A
QRE01	MEC-REAR COVER SUB;SGH-E880,ITALY,-,	GH75-06872A
	QRF03 PMO-EAR JACK COVER;SGH-E880,ABS+ELAS	GH72-20075A
	QIF01 PMO-IF COVER;SGH-E880,PC+ELASTOMER,S	GH72-20076A
	QVO01 MEC-VOLUME KEY;SGH-E880,ITALY,-,-,SI	GH75-06870A
	QCK01 MEC-CAMERA KEY;SGH-E880,ITALY,-,-,SI	GH75-06871A

Description	SEC CODE
ANTENNA-CHIP;2400-2484MHz,-,-,50oh	4202-001034
BAG PE;LDPE,T0.05,W80,L180,TRP,-,-	6902-000634
CHARGER-SGHE880 TC,EU,BLACK;TCH237EB	GH44-00998A
UNIT-EARPHONE;SGH-C230,EM-SS550E-STB	GH59-02166A
LABEL(P)-WATER SOAK;SCH-X110,NORGE,1	GH68-02026A
LABEL(R)-MAIN;SGH-E880,-,MAT,T0.1,30	GH68-06741A
MANUAL-WEEE CARD;SGH-E720,SEC,ENGLIS	GH68-07013A
MANUAL-USER;SGH-E880,XEF,FRENCH,FRAN	GH68-07309A
CUSHION-CASE;SGH-E880,PULP,T1.0,179,	GH69-02815A
BOX(P)-UNIT MAIN;SGH-E880,SC300+F(KO	GH69-02892A
MPR-HAND STRAP;SCH-A690,LEATHER,-,BL	GH74-05907A
MPR-BOHO VINYL FPCB CON;SGH-E880,BLU	GH74-13315A
MPR-GASKET LCD DOME;SGH-E880,GASKET,	GH74-13811A
MPR-GASKET LCD FPCB PBA;SGH-E880,GAS	GH74-13812A
MPR-GASKET EAR JACK;SGH-E880,GASKET,	GH74-13814A
MPR-GASKET MAIN LCD FPCB;SGH-E880,GA	GH74-13817A
MPR-GASKET DOME SHEET;SGH-E880,GASKE	GH74-13818A
MPR-TAPE SCR HOL CAP;SGH-E880,PC SHE	GH74-13820A
MPR-BOHO VINYL CAM BLUE;SGH-E880,INS	GH74-14397A
MPR-BOHO VINYL LCD CON;SGH-E880,INSU	GH74-14439A
MPR-BOHO VINYL BLUETOOTH;SGH-E880,HO	GH74-15013A
MPR-TAPE LCD SIDE BLACK;SGH-E880,3M	GH74-15014A
MPR-BOHO VINYL KEYPAD;SGH-E880,3M 41	GH74-15016A
MPR-CON GUIDE SHEET;SGH-E880,PC SHEE	GH74-15498A
MPR-BOHO VINYL PIECE;SGH-E880,3M4187	GH74-16153A
MEC-CAMERA LEVER;SGH-E880,ITALY,-,-,	GH75-06868A
MEC-MIC HOLDER;SGH-E880,ITALY,-,-,SI	GH75-06869A
MEC-HINGE;SGH-E880,ITALY,-,-,SIL,-,-	GH75-06881A

### 3-3. Test Jig (GH80-03307A)



3-3-1. RF Test Cable  
(GH39-00283A)



3-3-2. Logic Test Cable  
(GH39-00388A)



3-3-3. Serial Cable

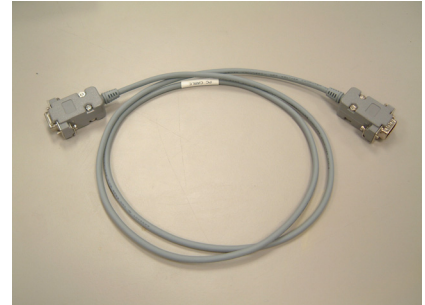

3-3-4. Power Supply  
Cable

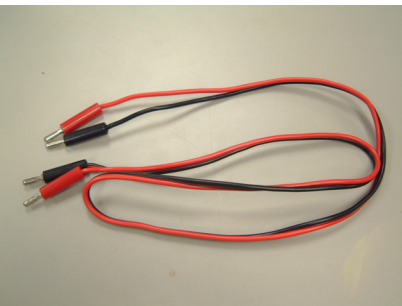

3-3-5. DATA Link CABLE  
(GH39-00404A)



3-3-6. Travel Charger  
(GH44-00861A)

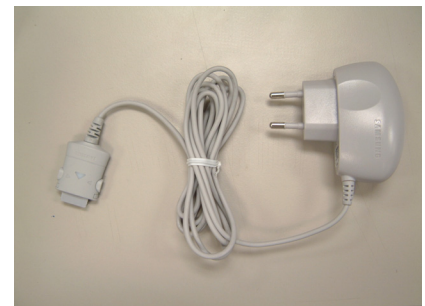

## 4. SGH-E880 MAIN Electrical Parts List

Design LOC	SEC Code	Discription
GH92-01992A		PBA MAIN-SGHE880
0403-001387	ZD603	DIODE-ZENER
0406-001167	ZD600	DIODE-TVS
0406-001167	ZD601	DIODE-TVS
0504-001140	Q201	TR-DIGITAL
0504-001140	Q300	TR-DIGITAL
0504-001141	Q200	TR-DIGITAL
0601-002053	LED500	LED
0601-002053	LED501	LED
0601-002053	LED502	LED
0601-002053	LED503	LED
0601-002053	LED504	LED
0601-002053	LED505	LED
0601-002053	LED506	LED
0601-002053	LED507	LED
0801-002529	U205	IC-CMOS LOGIC
1001-001306	U400	IC-ANALOG MULTIPLEX
1006-001313	U203	IC-BUS TRANSCEIVER
1009-001018	U201	IC-HALL EFFECT S/W
1108-000003	U300	IC-MCP
1201-002007	U402	IC-AUDIO AMP
1201-002218	U701	IC-POWER AMP
1203-002625	U600	IC-POSI.FIXED REG
1203-003105	U202	IC-POSI.FIXED REG
1203-003169	U304	IC-MULTI REG
1203-003428	U303	IC-DC/DC CONVERTER
1203-003472	U100	IC-POWER SUPERVISOR
1204-001915	U204	IC-FILTER
1204-002138	U401	IC-MELODY
1205-002433	U700	IC-TRANSCEIVER
1205-002612	U301	IC-CODEC
1205-002613	U302	IC-CODEC
1404-001165	U101	THERMISTOR-NTC
1405-001082	V502	VARISTOR
1405-001082	V503	VARISTOR
1405-001082	V504	VARISTOR
1405-001082	V505	VARISTOR
1405-001082	V506	VARISTOR
1405-001082	ZD400	VARISTOR
1405-001082	ZD401	VARISTOR
1405-001082	ZD402	VARISTOR
1405-001082	ZD403	VARISTOR
1405-001082	ZD404	VARISTOR

Design LOC	SEC Code	Discription
1405-001082	ZD405	VARISTOR
1405-001082	ZD406	VARISTOR
1405-001082	ZD407	VARISTOR
1405-001108	ZD408	VARISTOR
1405-001108	ZD409	VARISTOR
1405-001108	ZD500	VARISTOR
1405-001108	ZD501	VARISTOR
1405-001108	ZD502	VARISTOR
1405-001108	ZD503	VARISTOR
1405-001108	ZD504	VARISTOR
1405-001108	ZD505	VARISTOR
1405-001108	ZD506	VARISTOR
1405-001108	ZD507	VARISTOR
1405-001108	ZD508	VARISTOR
1405-001108	ZD509	VARISTOR
1405-001108	ZD511	VARISTOR
1405-001108	ZD513	VARISTOR
1405-001108	ZD514	VARISTOR
1405-001108	ZD515	VARISTOR
1405-001108	ZD516	VARISTOR
1405-001108	ZD517	VARISTOR
1405-001108	ZD604	VARISTOR
2007-000138	R700	R-CHIP
2007-000140	R202	R-CHIP
2007-000141	R311	R-CHIP
2007-000141	R704	R-CHIP
2007-000142	R414	R-CHIP
2007-000142	R419	R-CHIP
2007-000143	R319	R-CHIP
2007-000143	R321	R-CHIP
2007-000148	R452	R-CHIP
2007-000148	R702	R-CHIP
2007-000155	R201	R-CHIP
2007-000157	R212	R-CHIP
2007-000157	R304	R-CHIP
2007-000159	R218	R-CHIP
2007-000160	R324	R-CHIP
2007-000162	R203	R-CHIP
2007-000162	R208	R-CHIP
2007-000162	R310	R-CHIP
2007-000162	R323	R-CHIP
2007-000162	R420	R-CHIP
2007-000162	R422	R-CHIP



SGH-E880 Main Electrical Parts List

Design LOC	SEC Code	Discription
2007-000162	R701	R-CHIP
2007-000170	R303	R-CHIP
2007-000171	R108	R-CHIP
2007-000171	R313	R-CHIP
2007-000171	R314	R-CHIP
2007-000171	R429	R-CHIP
2007-000171	R431	R-CHIP
2007-000171	R433	R-CHIP
2007-000171	R434	R-CHIP
2007-000171	R436	R-CHIP
2007-000171	R451	R-CHIP
2007-000171	R617	R-CHIP
2007-000172	R209	R-CHIP
2007-000172	R316	R-CHIP
2007-000172	R317	R-CHIP
2007-001119	R442	R-CHIP
2007-001290	R402	R-CHIP
2007-001290	R437	R-CHIP
2007-001291	R705	R-CHIP
2007-001291	R708	R-CHIP
2007-001292	R439	R-CHIP
2007-001292	R440	R-CHIP
2007-001301	R515	R-CHIP
2007-001301	R516	R-CHIP
2007-001301	R517	R-CHIP
2007-001301	R518	R-CHIP
2007-001301	R519	R-CHIP
2007-001301	R520	R-CHIP
2007-001301	R534	R-CHIP
2007-001301	R535	R-CHIP
2007-001307	R706	R-CHIP
2007-001307	R707	R-CHIP
2007-001307	R709	R-CHIP
2007-001307	R710	R-CHIP
2007-001319	R103	R-CHIP
2007-001323	R413	R-CHIP
2007-001323	R418	R-CHIP
2007-001323	R618	R-CHIP
2007-001325	R403	R-CHIP
2007-002797	R703	R-CHIP
2007-007107	R406	R-CHIP
2007-007107	R409	R-CHIP
2007-007107	R411	R-CHIP

Design LOC	SEC Code	Discription
2007-007107	R446	R-CHIP
2007-007107	R449	R-CHIP
2007-007138	R444	R-CHIP
2007-007138	R445	R-CHIP
2007-007138	R447	R-CHIP
2007-007138	R448	R-CHIP
2007-007142	R104	R-CHIP
2007-007142	R315	R-CHIP
2007-007142	R410	R-CHIP
2007-007142	R412	R-CHIP
2007-007142	R421	R-CHIP
2007-007142	R423	R-CHIP
2007-007306	R105	R-CHIP
2007-007308	R113	R-CHIP
2007-007308	R405	R-CHIP
2007-007308	R408	R-CHIP
2007-007314	R106	R-CHIP
2007-008045	R312	R-CHIP
2007-008052	R112	R-CHIP
2007-008052	R712	R-CHIP
2007-008055	R107	R-CHIP
2007-008055	R204	R-CHIP
2007-008055	R300	R-CHIP
2007-008055	R302	R-CHIP
2007-008055	R325	R-CHIP
2007-008055	R427	R-CHIP
2007-008055	R428	R-CHIP
2007-008419	R425	R-CHIP
2007-008419	R426	R-CHIP
2007-008419	R521	R-CHIP
2007-008419	R604	R-CHIP
2007-008419	R613	R-CHIP
2007-008419	R614	R-CHIP
2007-008419	R615	R-CHIP
2007-008483	R301	R-CHIP
2007-008483	R533	R-CHIP
2007-008483	R603	R-CHIP
2007-008483	R621	R-CHIP
2007-008531	R210	R-CHIP
2007-008542	R110	R-CHIP
2007-008542	R327	R-CHIP
2007-008542	R455	R-CHIP
2007-008542	R608	R-CHIP

Design LOC	SEC Code	Discription
2007-008542	R609	R-CHIP
2007-008542	R610	R-CHIP
2007-008542	R611	R-CHIP
2007-008542	R612	R-CHIP
2007-008542	R620	R-CHIP
2007-008549	R616	R-CHIP
2007-008806	R216	R-CHIP
2007-008806	R500	R-CHIP
2007-008806	R501	R-CHIP
2007-008806	R502	R-CHIP
2007-008806	R503	R-CHIP
2007-008806	R504	R-CHIP
2007-008806	R505	R-CHIP
2007-008806	R506	R-CHIP
2007-008806	R507	R-CHIP
2007-008806	R508	R-CHIP
2007-008806	R509	R-CHIP
2007-008806	R522	R-CHIP
2007-008806	R523	R-CHIP
2007-008806	R524	R-CHIP
2007-008806	R525	R-CHIP
2007-008806	R526	R-CHIP
2007-008806	R527	R-CHIP
2007-008806	R528	R-CHIP
2007-008806	R529	R-CHIP
2007-008806	R530	R-CHIP
2007-008806	R531	R-CHIP
2007-009084	R328	R-CHIP
2007-009084	R329	R-CHIP
2203-000233	C111	C-CER,CHIP
2203-000233	C437	C-CER,CHIP
2203-000233	C438	C-CER,CHIP
2203-000233	C703	C-CER,CHIP
2203-000233	C710	C-CER,CHIP
2203-000233	C717	C-CER,CHIP
2203-000233	C729	C-CER,CHIP
2203-000233	C730	C-CER,CHIP
2203-000233	C731	C-CER,CHIP
2203-000254	C102	C-CER,CHIP
2203-000254	C124	C-CER,CHIP
2203-000254	C203	C-CER,CHIP
2203-000254	C206	C-CER,CHIP
2203-000254	C207	C-CER,CHIP

Design LOC	SEC Code	Discription
2203-000254	C215	C-CER,CHIP
2203-000254	C218	C-CER,CHIP
2203-000254	C508	C-CER,CHIP
2203-000254	C621	C-CER,CHIP
2203-000254	C705	C-CER,CHIP
2203-000254	C707	C-CER,CHIP
2203-000254	C708	C-CER,CHIP
2203-000254	C711	C-CER,CHIP
2203-000254	C715	C-CER,CHIP
2203-000254	C716	C-CER,CHIP
2203-000254	C718	C-CER,CHIP
2203-000278	C303	C-CER,CHIP
2203-000278	C304	C-CER,CHIP
2203-000330	C216	C-CER,CHIP
2203-000330	C217	C-CER,CHIP
2203-000359	C421	C-CER,CHIP
2203-000386	C431	C-CER,CHIP
2203-000386	C432	C-CER,CHIP
2203-000386	C433	C-CER,CHIP
2203-000386	C434	C-CER,CHIP
2203-000425	C709	C-CER,CHIP
2203-000438	C403	C-CER,CHIP
2203-000654	C407	C-CER,CHIP
2203-000654	C422	C-CER,CHIP
2203-000812	C106	C-CER,CHIP
2203-000812	C107	C-CER,CHIP
2203-000812	C108	C-CER,CHIP
2203-000812	C414	C-CER,CHIP
2203-000812	C415	C-CER,CHIP
2203-000812	C416	C-CER,CHIP
2203-000812	C420	C-CER,CHIP
2203-000812	C702	C-CER,CHIP
2203-000812	C712	C-CER,CHIP
2203-000854	C410	C-CER,CHIP
2203-000854	C412	C-CER,CHIP
2203-000854	C423	C-CER,CHIP
2203-000854	C425	C-CER,CHIP
2203-000854	C440	C-CER,CHIP
2203-000854	C441	C-CER,CHIP
2203-000885	C317	C-CER,CHIP
2203-000995	C701	C-CER,CHIP
2203-000995	C713	C-CER,CHIP
2203-000995	C725	C-CER,CHIP

SGH-E880 Main Electrical Parts List

Design LOC	SEC Code	Discription
2203-001201	C737	C-CER,CHIP
2203-001405	C208	C-CER,CHIP
2203-001405	C406	C-CER,CHIP
2203-002677	C723	C-CER,CHIP
2203-002677	C724	C-CER,CHIP
2203-002677	C732	C-CER,CHIP
2203-002759	C446	C-CER,CHIP
2203-002759	C448	C-CER,CHIP
2203-005061	C103	C-CER,CHIP
2203-005061	C104	C-CER,CHIP
2203-005061	C110	C-CER,CHIP
2203-005061	C115	C-CER,CHIP
2203-005061	C122	C-CER,CHIP
2203-005061	C400	C-CER,CHIP
2203-005061	C401	C-CER,CHIP
2203-005061	C404	C-CER,CHIP
2203-005061	C405	C-CER,CHIP
2203-005061	C409	C-CER,CHIP
2203-005061	C620	C-CER,CHIP
2203-005061	C706	C-CER,CHIP
2203-005234	C735	C-CER,CHIP
2203-005288	C721	C-CER,CHIP
2203-005288	C722	C-CER,CHIP
2203-005288	C733	C-CER,CHIP
2203-005482	C200	C-CER,CHIP
2203-005482	C201	C-CER,CHIP
2203-005482	C204	C-CER,CHIP
2203-005482	C205	C-CER,CHIP
2203-005482	C209	C-CER,CHIP
2203-005482	C210	C-CER,CHIP
2203-005482	C213	C-CER,CHIP
2203-005482	C214	C-CER,CHIP
2203-005482	C301	C-CER,CHIP
2203-005482	C305	C-CER,CHIP
2203-005482	C309	C-CER,CHIP
2203-005482	C318	C-CER,CHIP
2203-005482	C330	C-CER,CHIP
2203-005482	C334	C-CER,CHIP
2203-005482	C338	C-CER,CHIP
2203-005482	C339	C-CER,CHIP
2203-005482	C505	C-CER,CHIP
2203-005482	C600	C-CER,CHIP
2203-005482	C700	C-CER,CHIP

Design LOC	SEC Code	Discription
2203-005482	C719	C-CER,CHIP
2203-005736	C736	C-CER,CHIP
2203-005806	C219	C-CER,CHIP
2203-005806	C220	C-CER,CHIP
2203-005806	C429	C-CER,CHIP
2203-005806	C430	C-CER,CHIP
2203-006053	C300	C-CER,CHIP
2203-006053	C302	C-CER,CHIP
2203-006053	C444	C-CER,CHIP
2203-006090	C331	C-CER,CHIP
2203-006093	C211	C-CER,CHIP
2203-006093	C306	C-CER,CHIP
2203-006093	C307	C-CER,CHIP
2203-006093	C308	C-CER,CHIP
2203-006093	C316	C-CER,CHIP
2203-006093	C333	C-CER,CHIP
2203-006093	C616	C-CER,CHIP
2203-006093	C619	C-CER,CHIP
2203-006108	C112	C-CER,CHIP
2203-006108	C113	C-CER,CHIP
2203-006108	C116	C-CER,CHIP
2203-006108	C117	C-CER,CHIP
2203-006108	C118	C-CER,CHIP
2203-006108	C121	C-CER,CHIP
2203-006137	C119	C-CER,CHIP
2203-006137	C123	C-CER,CHIP
2203-006137	C447	C-CER,CHIP
2203-006137	C449	C-CER,CHIP
2203-006137	C704	C-CER,CHIP
2203-006141	C435	C-CER,CHIP
2203-006190	C411	C-CER,CHIP
2203-006190	C413	C-CER,CHIP
2203-006190	C418	C-CER,CHIP
2203-006190	C419	C-CER,CHIP
2203-006194	C623	C-CER,CHIP
2203-006208	C332	C-CER,CHIP
2203-006260	C326	C-CER,CHIP
2203-006260	C329	C-CER,CHIP
2203-006260	C450	C-CER,CHIP
2203-006324	C109	C-CER,CHIP
2203-006324	C212	C-CER,CHIP
2203-006324	C442	C-CER,CHIP
2203-006438	C451	C-CER,CHIP

Design LOC	SEC Code	Discription
2203-006438	C452	C-CER,CHIP
2203-006626	C507	C-CER,CHIP
2404-001225	C105	C-TA,CHIP
2404-001225	C114	C-TA,CHIP
2404-001225	C310	C-TA,CHIP
2404-001225	C314	C-TA,CHIP
2404-001225	C408	C-TA,CHIP
2404-001225	C417	C-TA,CHIP
2404-001225	C424	C-TA,CHIP
2404-001225	C426	C-TA,CHIP
2404-001240	C313	C-TA,CHIP
2404-001339	C335	C-TA,CHIP
2404-001339	C336	C-TA,CHIP
2404-001339	C337	C-TA,CHIP
2404-001339	C622	C-TA,CHIP
2404-001352	C714	C-TA,CHIP
2404-001380	C311	C-TA,CHIP
2404-001380	C312	C-TA,CHIP
2404-001392	C601	C-TA,CHIP
2703-001178	C720	INDUCTOR-SMD
2703-001180	L701	INDUCTOR-SMD
2703-001876	L705	INDUCTOR-SMD
2703-001907	L703	INDUCTOR-SMD
2703-002165	L704	INDUCTOR-SMD
2703-002547	L707	INDUCTOR-SMD
2703-002775	L301	INDUCTOR-SMD
2801-003747	OSC200	CRYSTAL-SMD
2801-004225	OSC300	CRYSTAL-SMD
2809-001284	OSC700	OSCILLATOR-VCTCXO
2901-001296	F500	FILTER-LC
2901-001296	F501	FILTER-LC
2901-001296	F502	FILTER-LC
2901-001296	F503	FILTER-LC
2901-001296	F504	FILTER-LC
2901-001296	F505	FILTER-LC
2901-001296	F506	FILTER-LC
2911-000003	F700	DUPLEXER-FEM
3301-001105	L700	CORE-FERRITE
3301-001438	L201	BEAD-SMD
3705-001358	CN700	CONNECTOR-COAXIAL
3708-001982	CN500	CONNECTOR-FPC/FFC /PIC
3711-005897	CN602	CONNECTOR-HEADER

Design LOC	SEC Code	Discription
3709-001229	CN100	CONNECTOR- CARD EDGE
3710-002225	CN601	CONNECTOR- INTERFACE
3722-002181	CN400	JACK-EAR PHONE
4302-001158	BAT100	BATTERY-LI(2ND)
4709-001350	U601	BLUETOOTH MODULE
GH09-00033A	U200	IC MICOM-SGHE720
GH41-00745A		PCB-SGHE880 MAIN
GH96-01773A		ELA UNIT-SGHE880
4202-001034		ANTENNA-CHIP
GH30-00180A		MICROPHONE-ASSY
GH59-01888A		UNIT-METAL DOME
GH59-01894A		UNIT-VOLUME KEY
GH59-01895A		UNIT-CAM KEY
GH74-13814A		MPR-GASKET EAR JACK
GH74-13818A		MPR-GASKET DOME SHEET

# 5. SGH-E880 PCB Diagrams

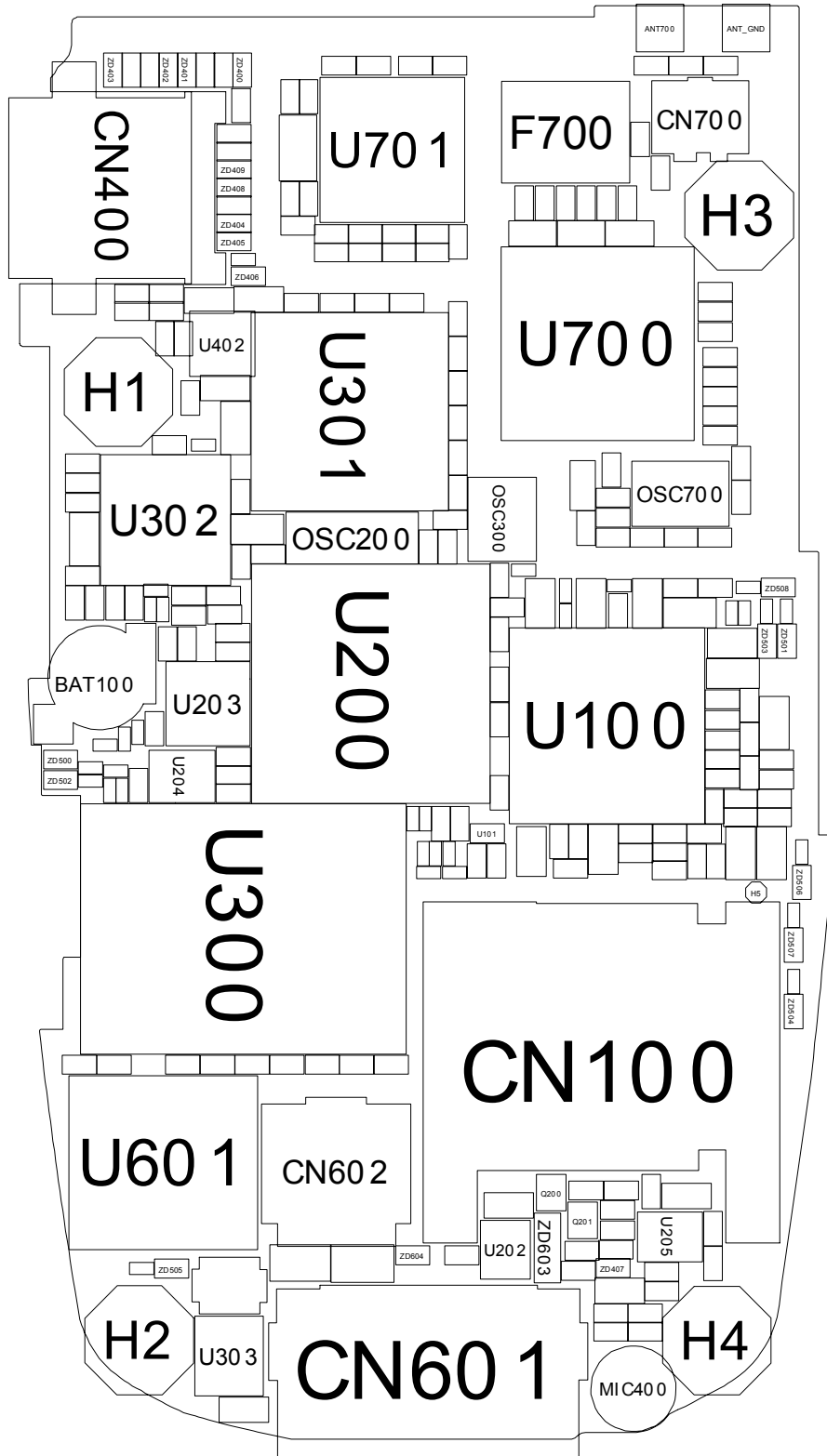

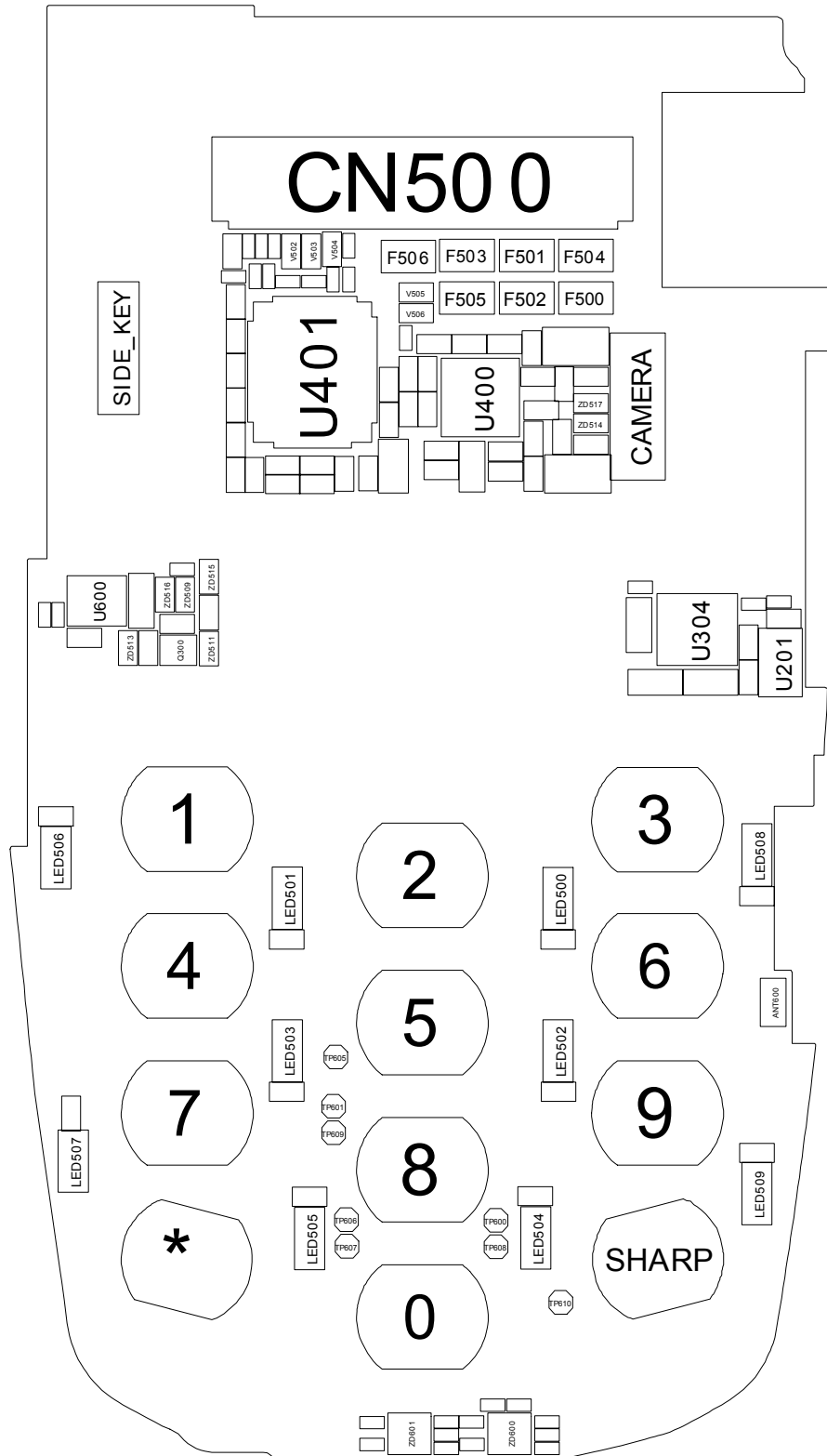

# 6. SGH-E880 Block Diagrams

## 6-1. Block Diagram

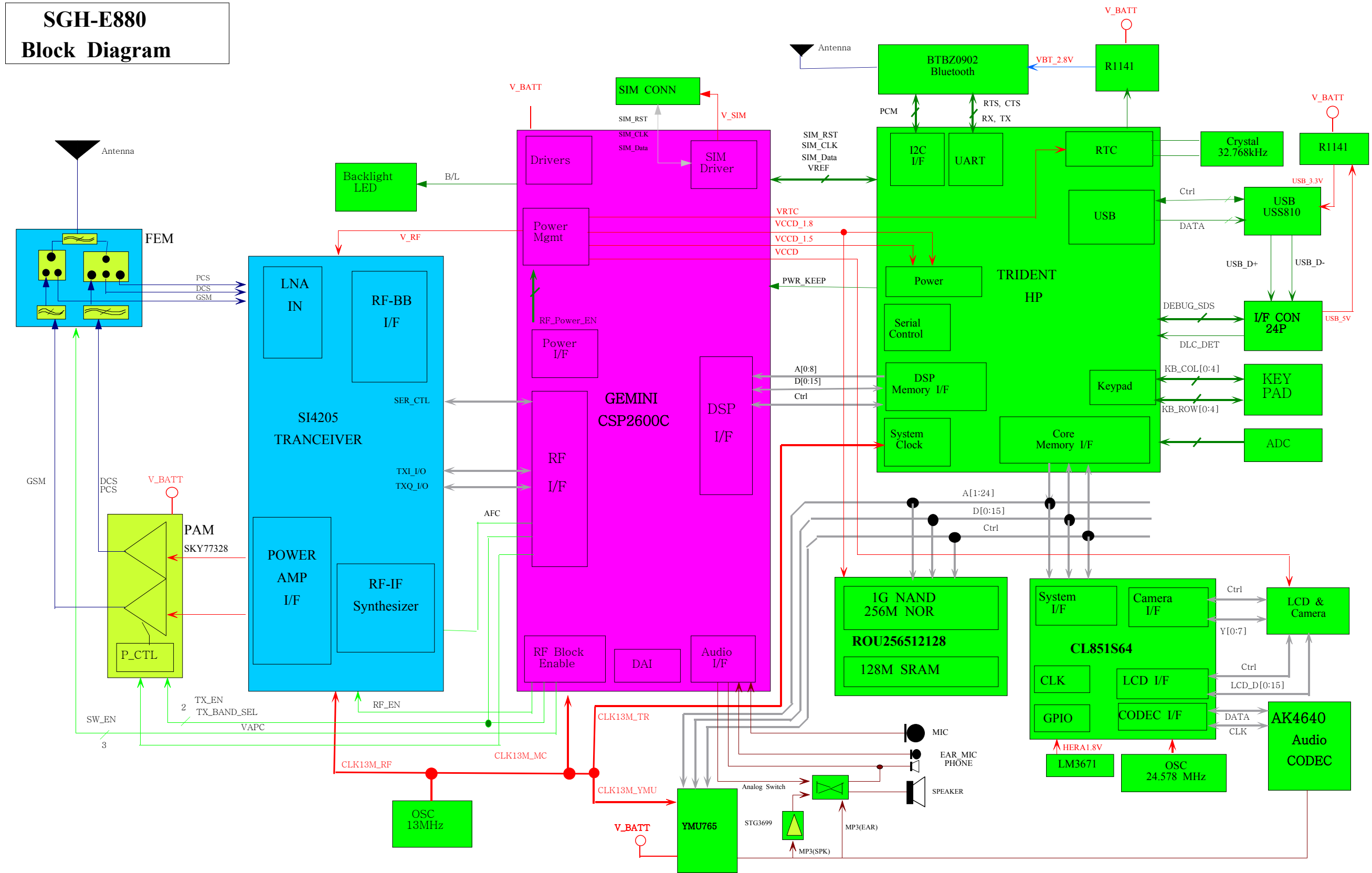

**SAMSUNG  
ELECTRONICS**

