

SAMSUNG

GSM TELEPHONE

SGH-E860V

SERVICE *Manual*

GSM TELEPHONE



CONTENTS

1. Specification
2. Flow Chart of Troubleshooting
3. Exploded Views and Parts List
4. Electrical Parts List
5. PCB Diagrams
6. Block Diagrams

1. SGH-E860V Specification

1-1. GSM General Specification

	GSM900 Phase 1	EGSM 900 Phase 2	DCS1800 Phase 1	PCS1900
Freq. Band[MHz] Uplink/Downlink	890~915 935~960	880~915 925~960	1710~1785 1805~1880	1850~1910 1930~1990
ARFCN range	1~124	0~124 & 975~1023	512~885	512~810
Tx/Rx spacing	45MHz	45MHz	95MHz	80MHz
Mod. Bit rate/ Bit Period	270.833kbps 3.692us	270.833kbps 3.692us	270.833kbps 3.692us	270.833kbps 3.692us
Time Slot Period/Frame Period	576.9us 4.615ms	576.9us 4.615ms	576.9us 4.615ms	576.9us 4.615ms
Modulation	0.3GMSK	0.3GMSK	0.3GMSK	0.3GMSK
MS Power	33dBm~13dBm	33dBm~5dBm	30dBm~0dBm	30dBm~0dBm
Power Class	5pcl ~ 15pcl	5pcl ~ 19pcl	0pcl ~ 15pcl	0pcl ~ 15pcl
Sensitivity	-102dBm	-102dBm	-100dBm	-100dBm
TDMA Mux	8	8	8	8
Cell Radius	35Km	35Km	2Km	-

1-2. GSM Tx Power Class

TX Power control level	GSM900	TX Power control level	DCS1800	TX Power control level	PCS1900
5	33±2 dBm	0	30±3 dBm	0	30±3 dBm
6	31±2 dBm	1	28±3 dBm	1	28±3 dBm
7	29±2 dBm	2	26±3 dBm	2	26±3 dBm
8	27±2 dBm	3	24±3 dBm	3	24±3 dBm
9	25±2 dBm	4	22±3 dBm	4	22±3 dBm
10	23±2 dBm	5	20±3 dBm	5	20±3 dBm
11	21±2 dBm	6	18±3 dBm	6	18±3 dBm
12	19±2 dBm	7	16±3 dBm	7	16±3 dBm
13	17±2 dBm	8	14±3 dBm	8	14±3 dBm
14	15±2 dBm	9	12±4 dBm	9	12±4 dBm
15	13±2 dBm	10	10±4 dBm	10	10±4 dBm
16	11±3 dBm	11	8±4dBm	11	8±4dBm
17	9±3dBm	12	6±4 dBm	12	6±4 dBm
18	7±3 dBm	13	4±4 dBm	13	4±4 dBm
19	5±3 dBm	14	2±5 dBm	14	2±5 dBm
		15	0±5 dBm	15	0±5 dBm

2. SGH-E860V Flow Chart of Troubleshooting

2-1 BASEBAND

2-1-1. Power ON

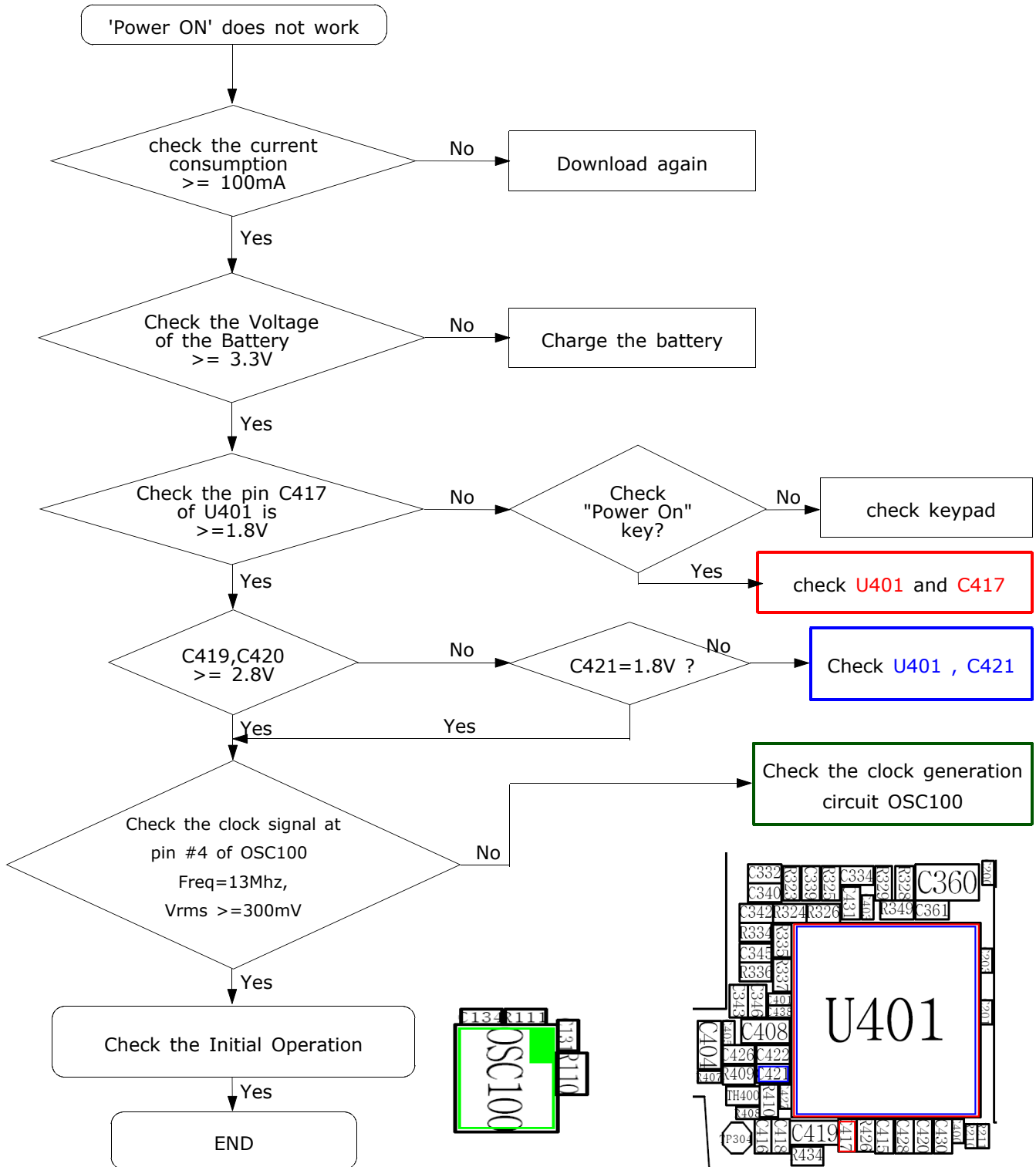

SGH-E860V Flow Chart of Troubleshooting

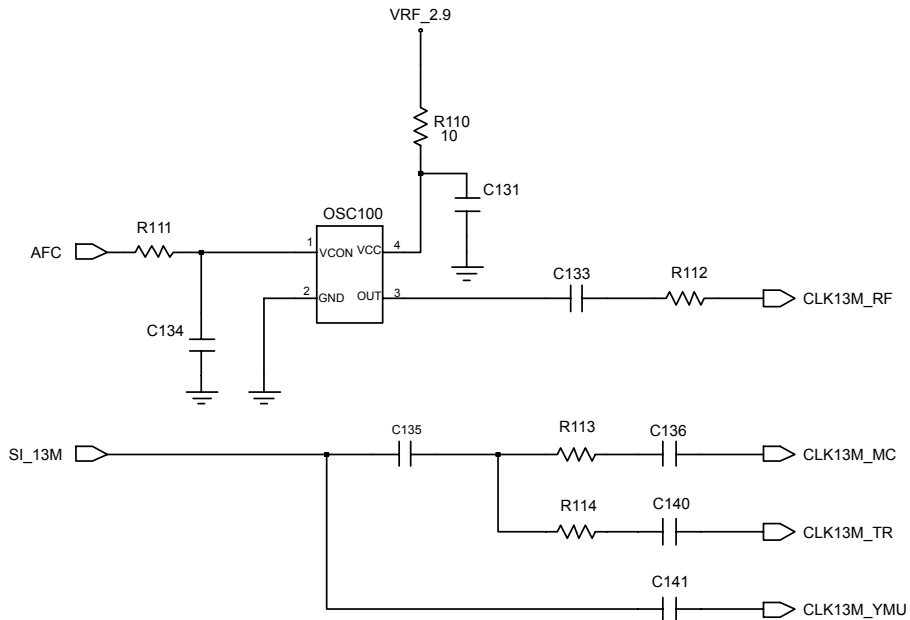
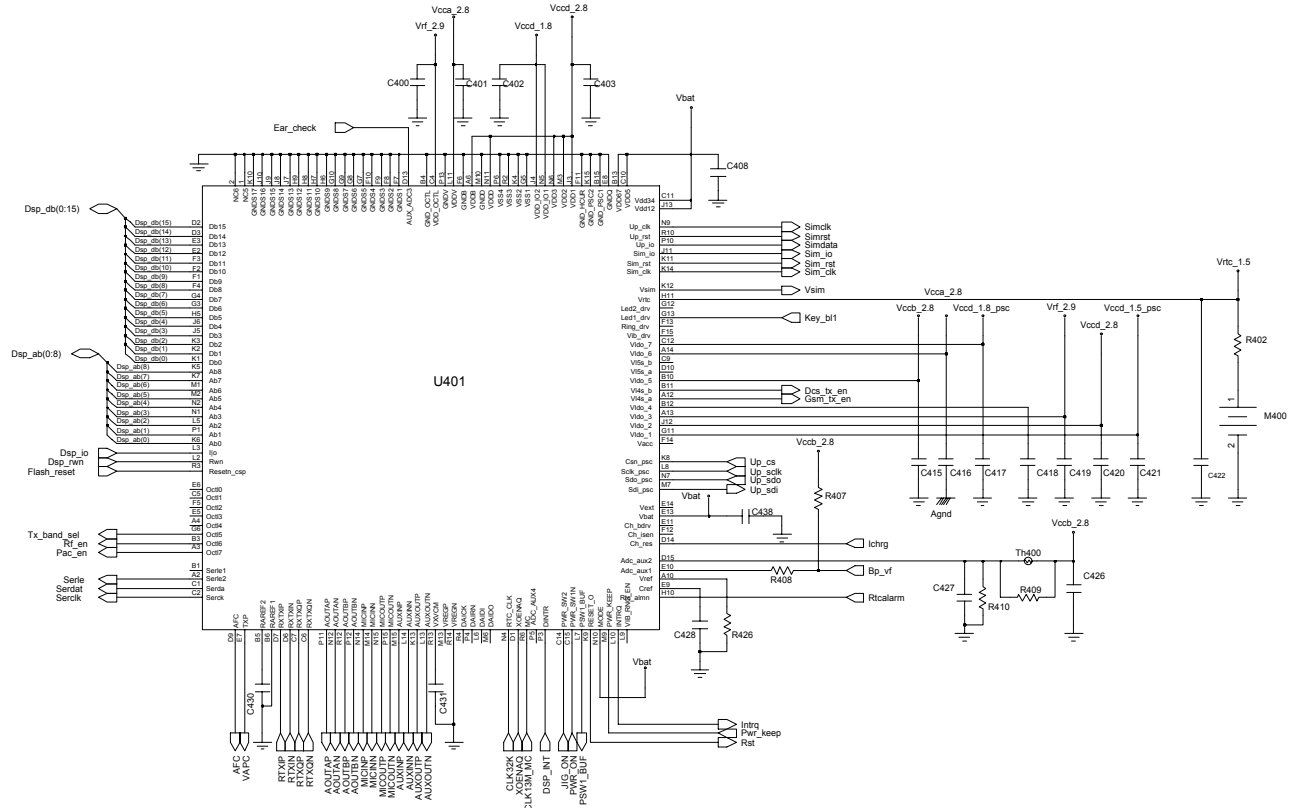

2-1-2. Initial

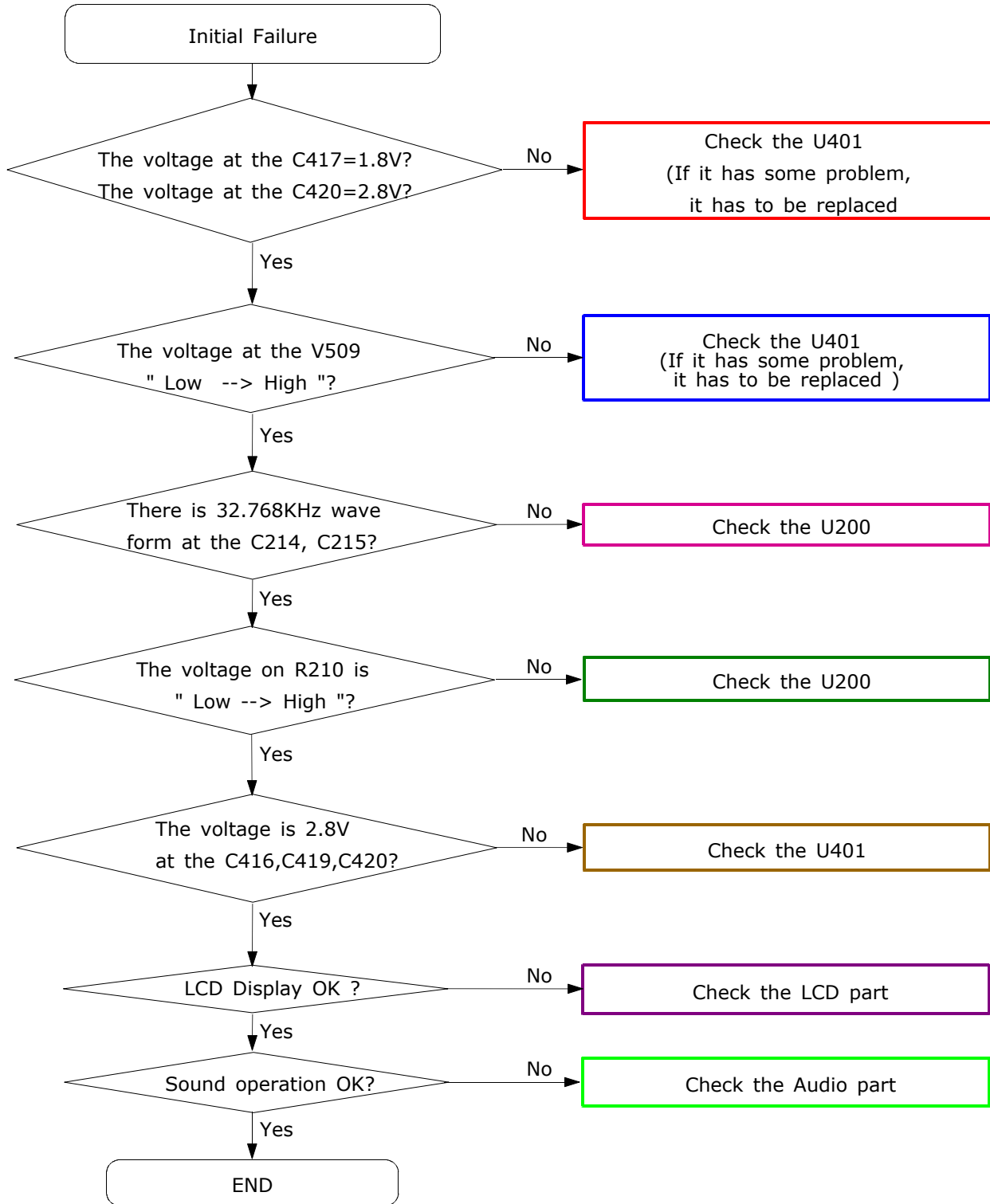

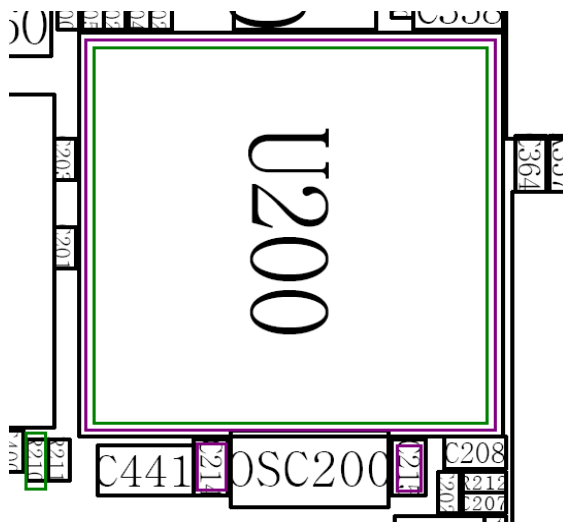
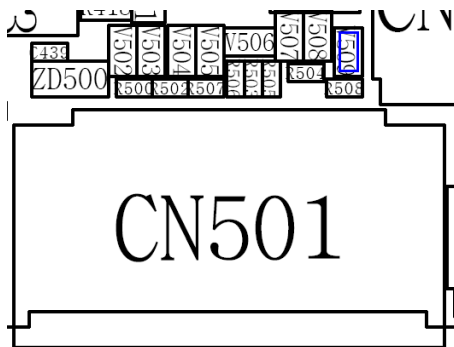
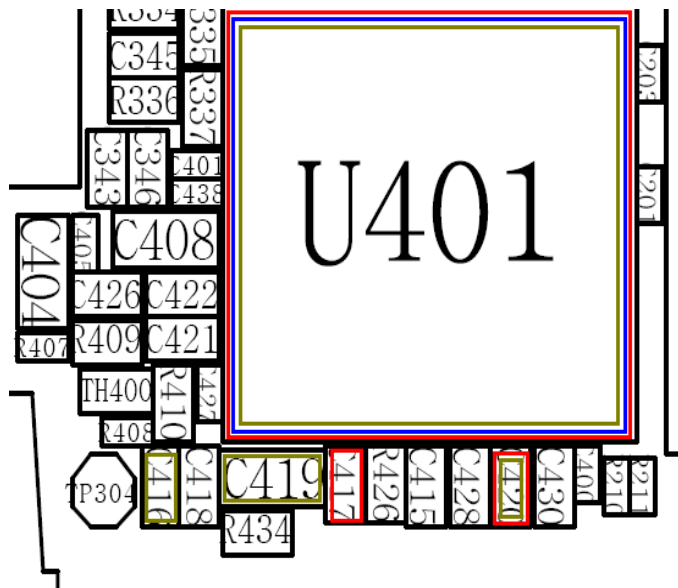

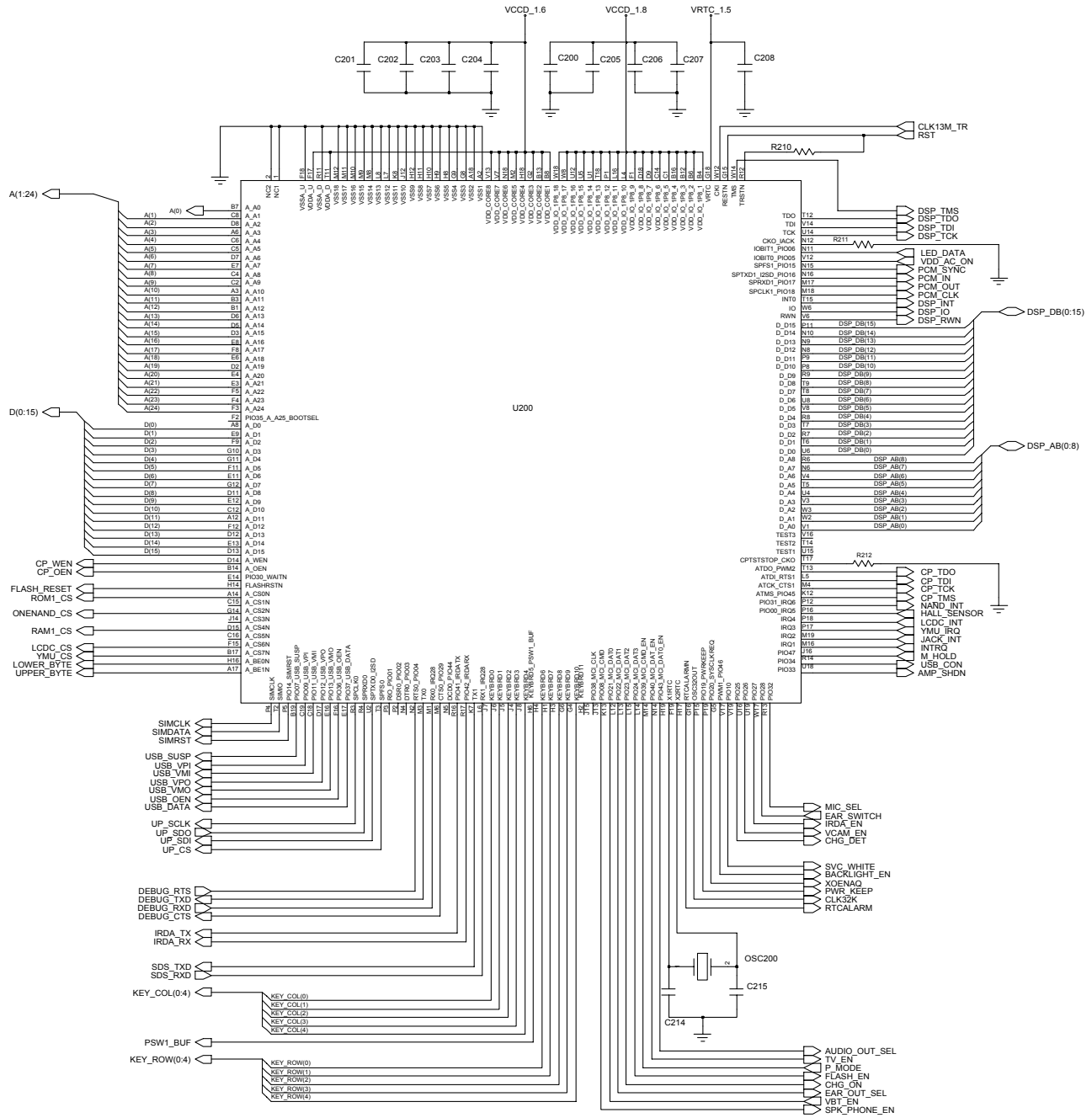

2-1-3. Sim Part

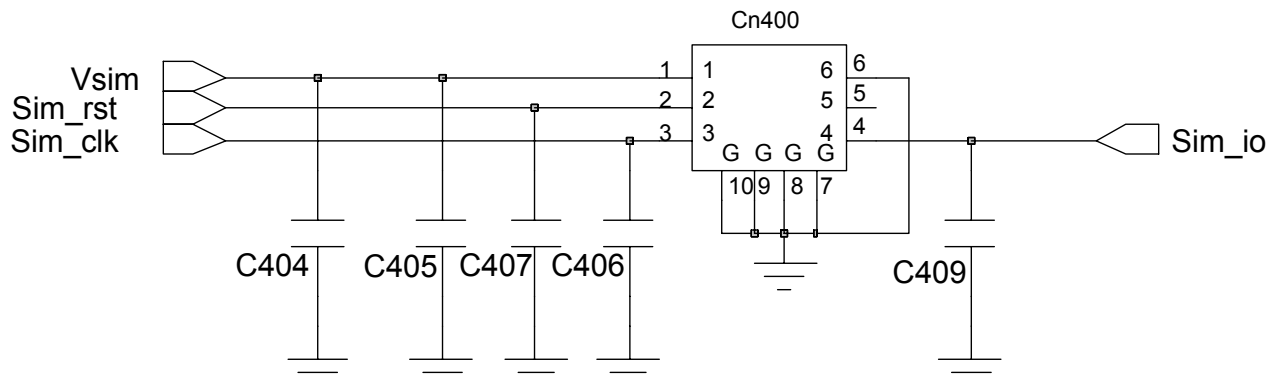
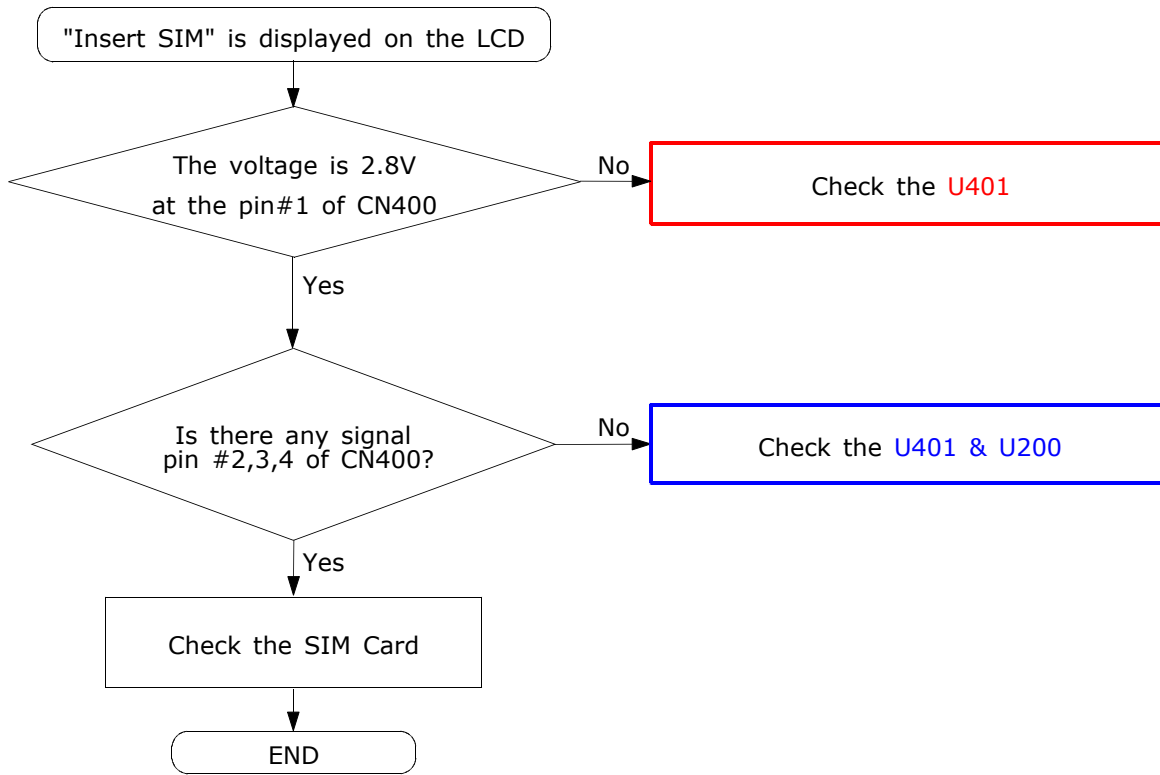

2-1-4. Microphone Part

* Call with Sim before testing.

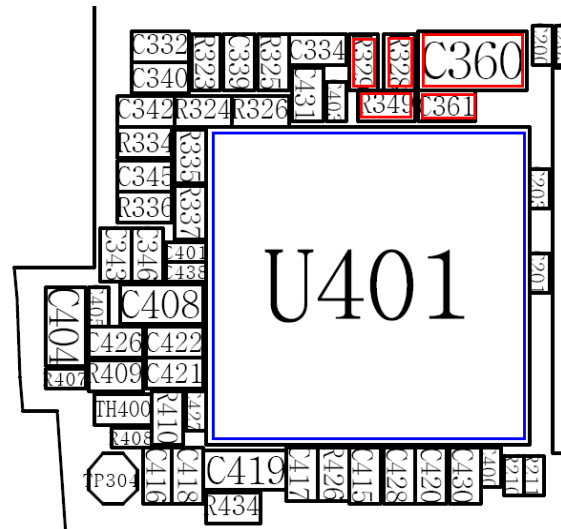
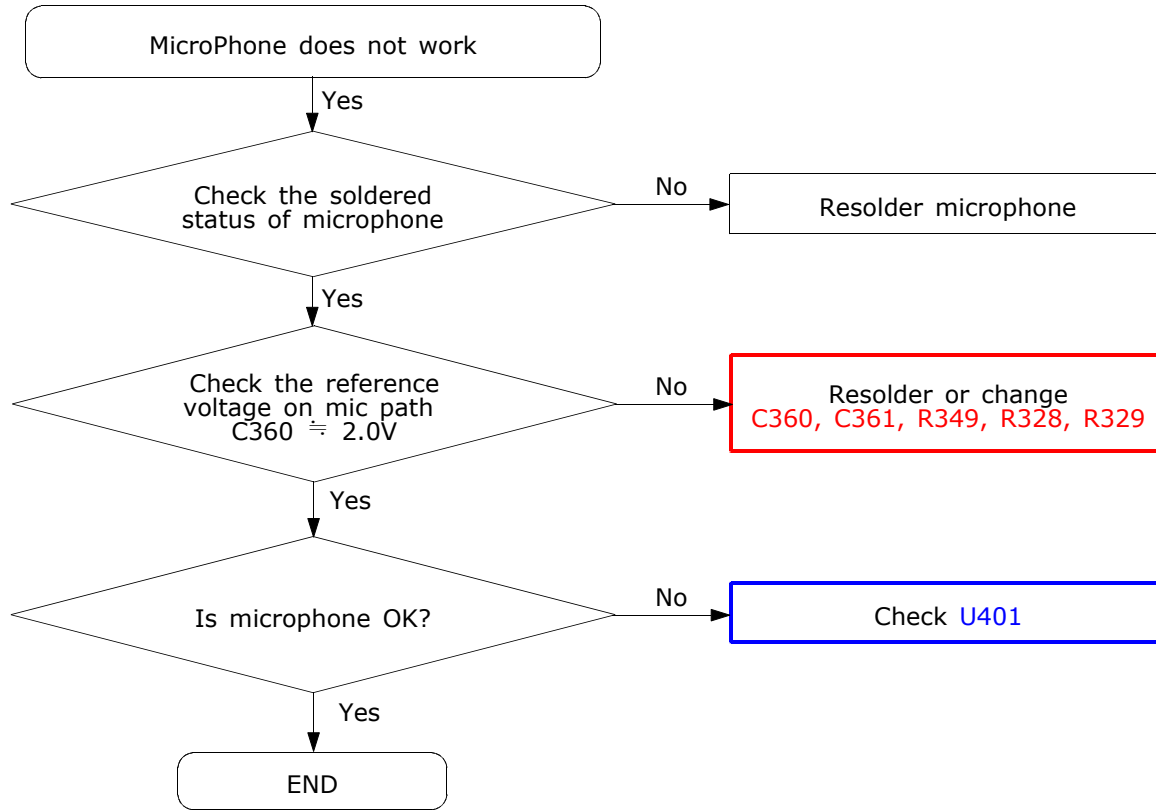

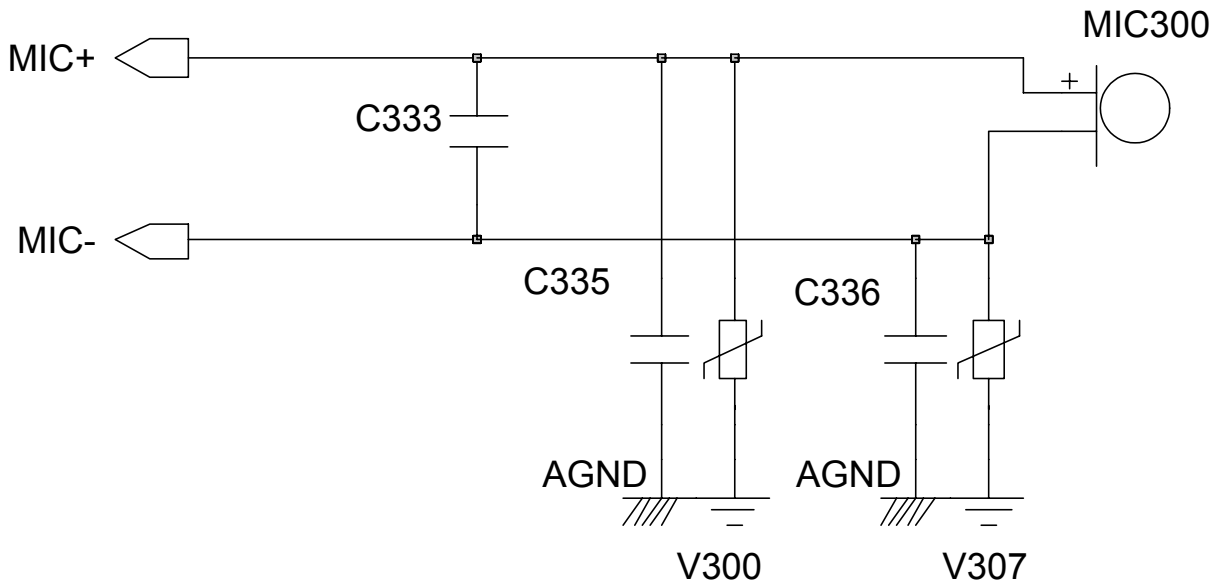
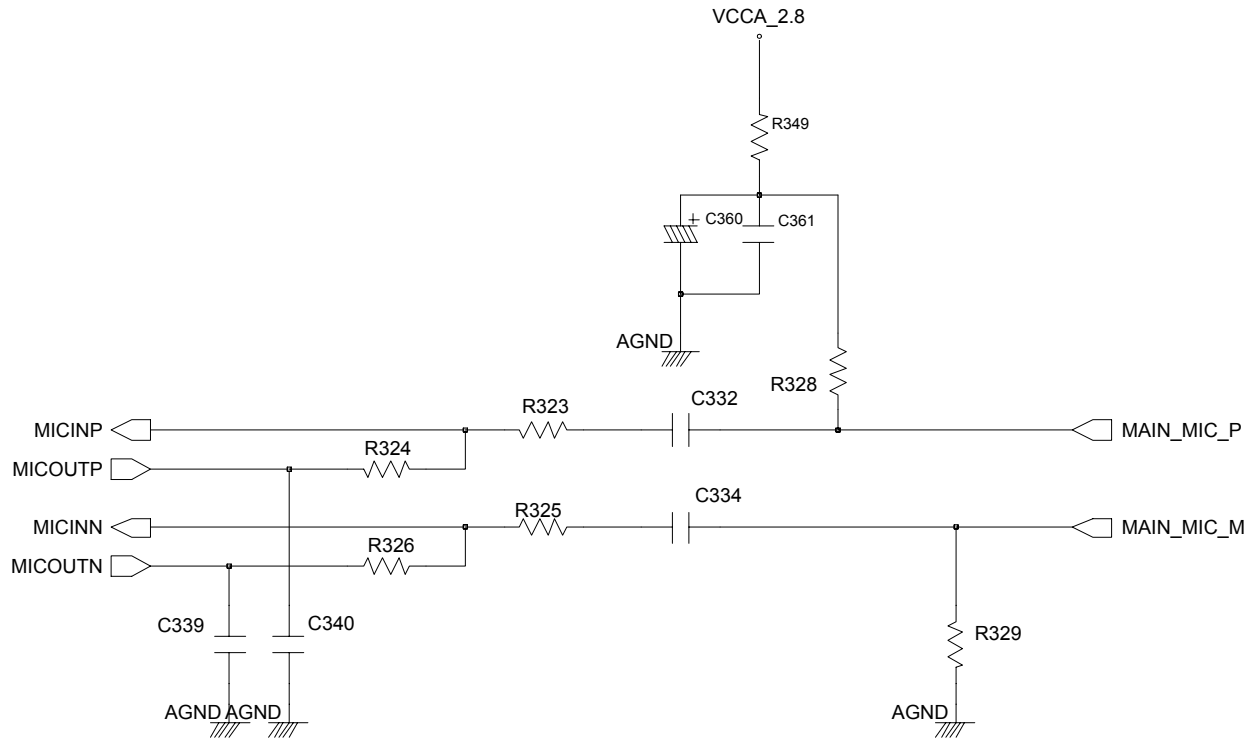

2-1-5. Bluetooth Part

* When you play MPEG file, if Audio is not active

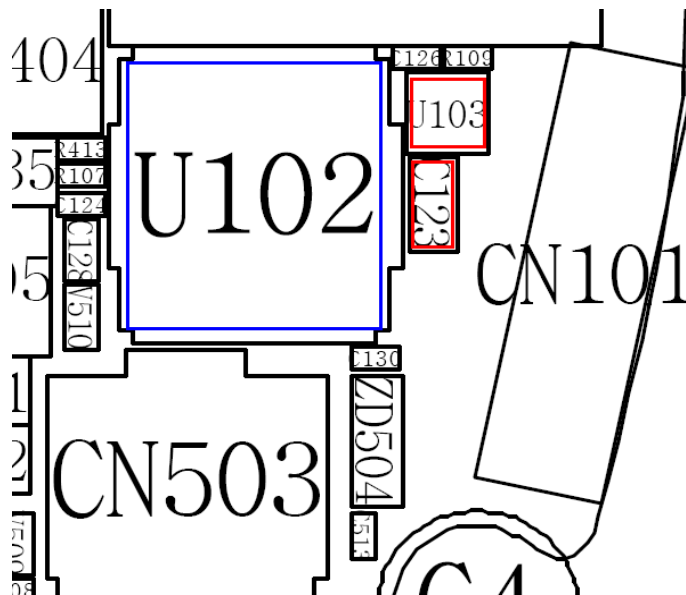
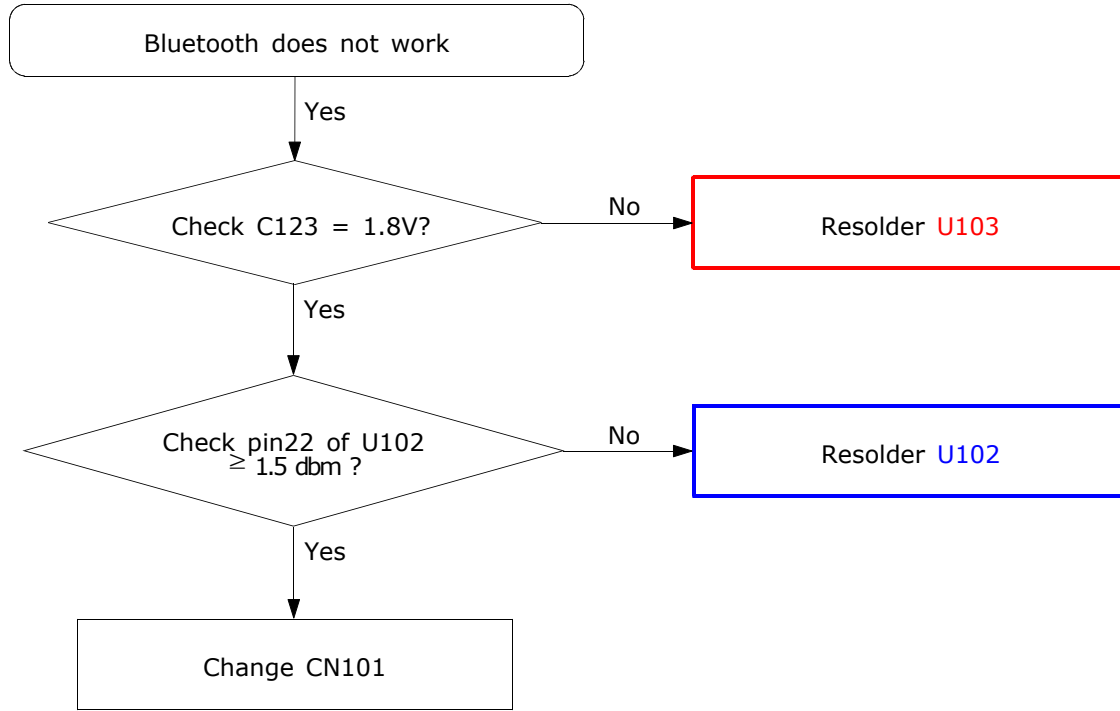

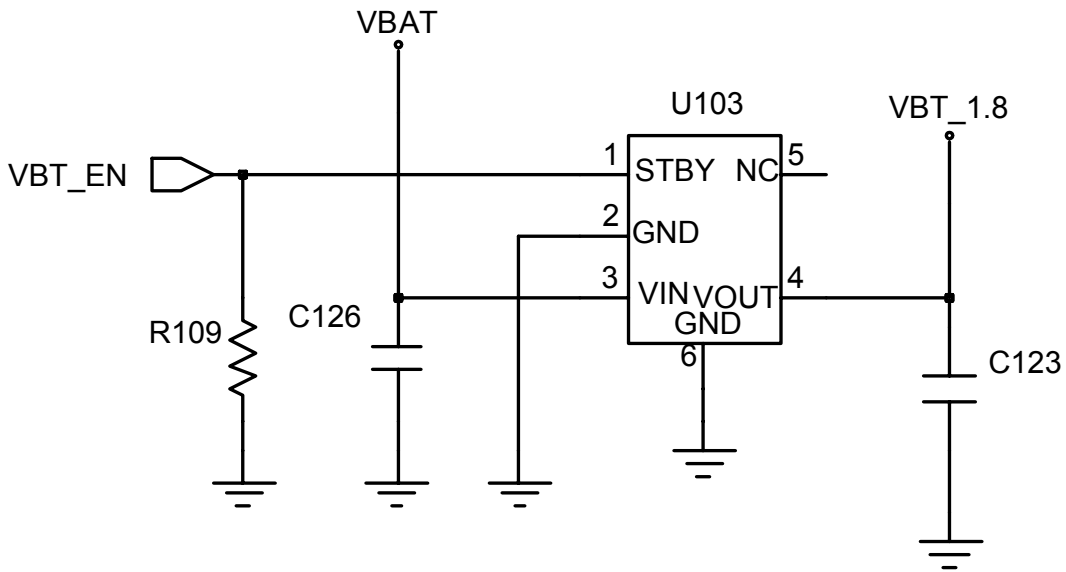
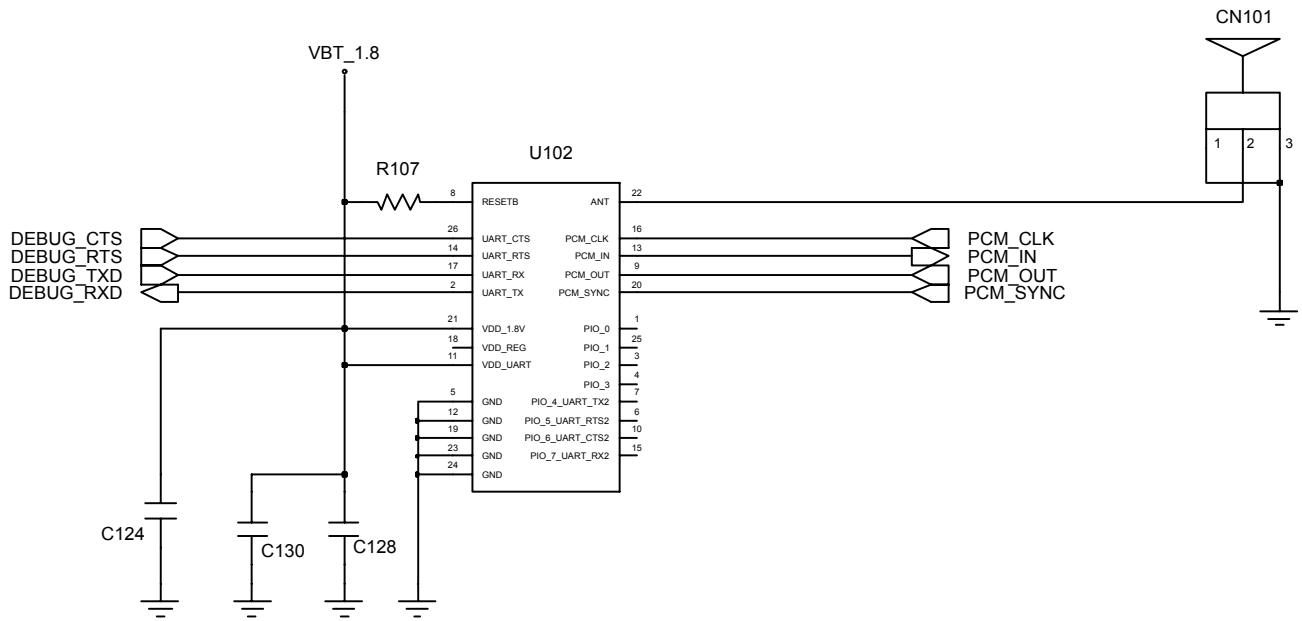

2-1-6. Speaker Part

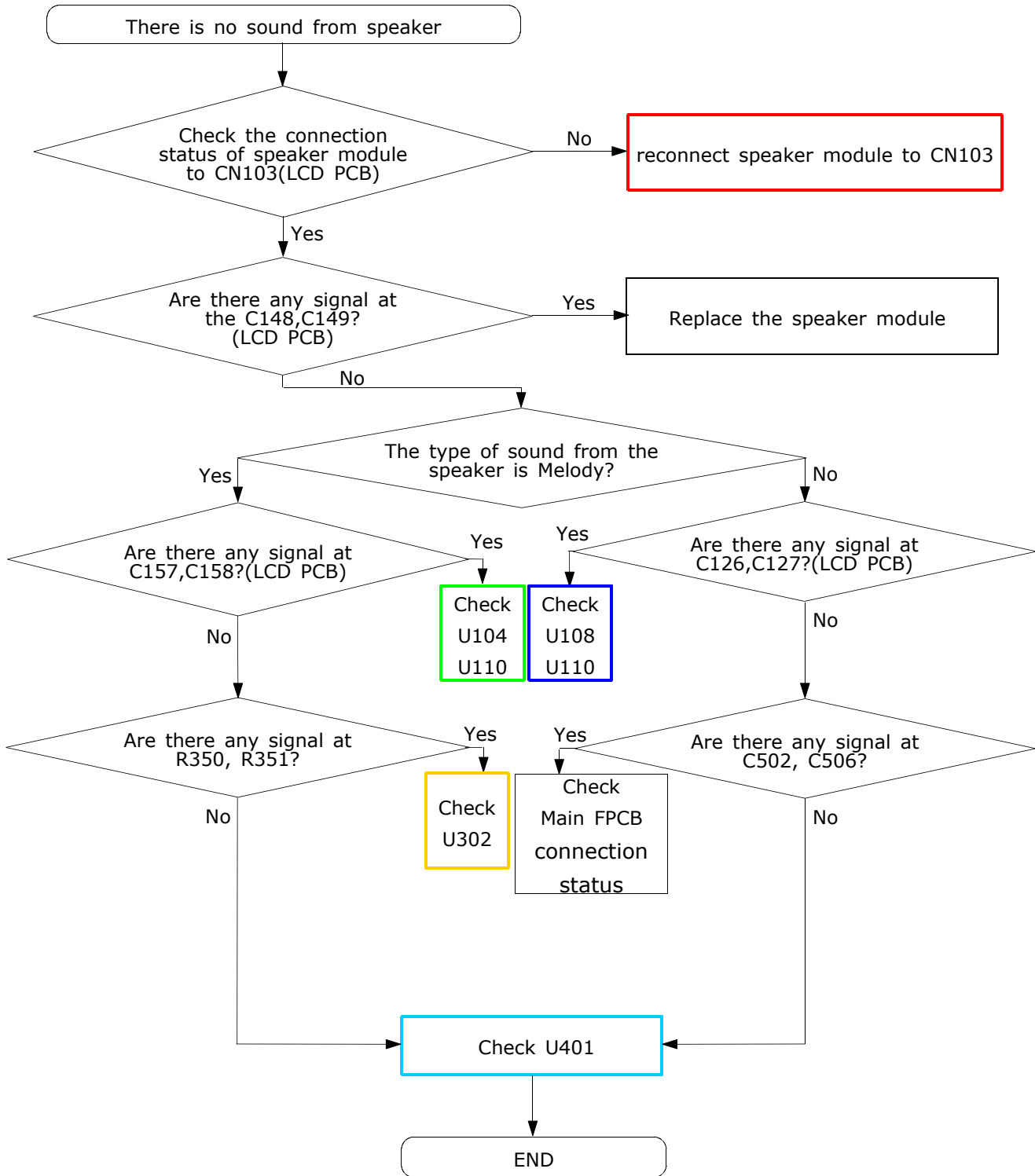

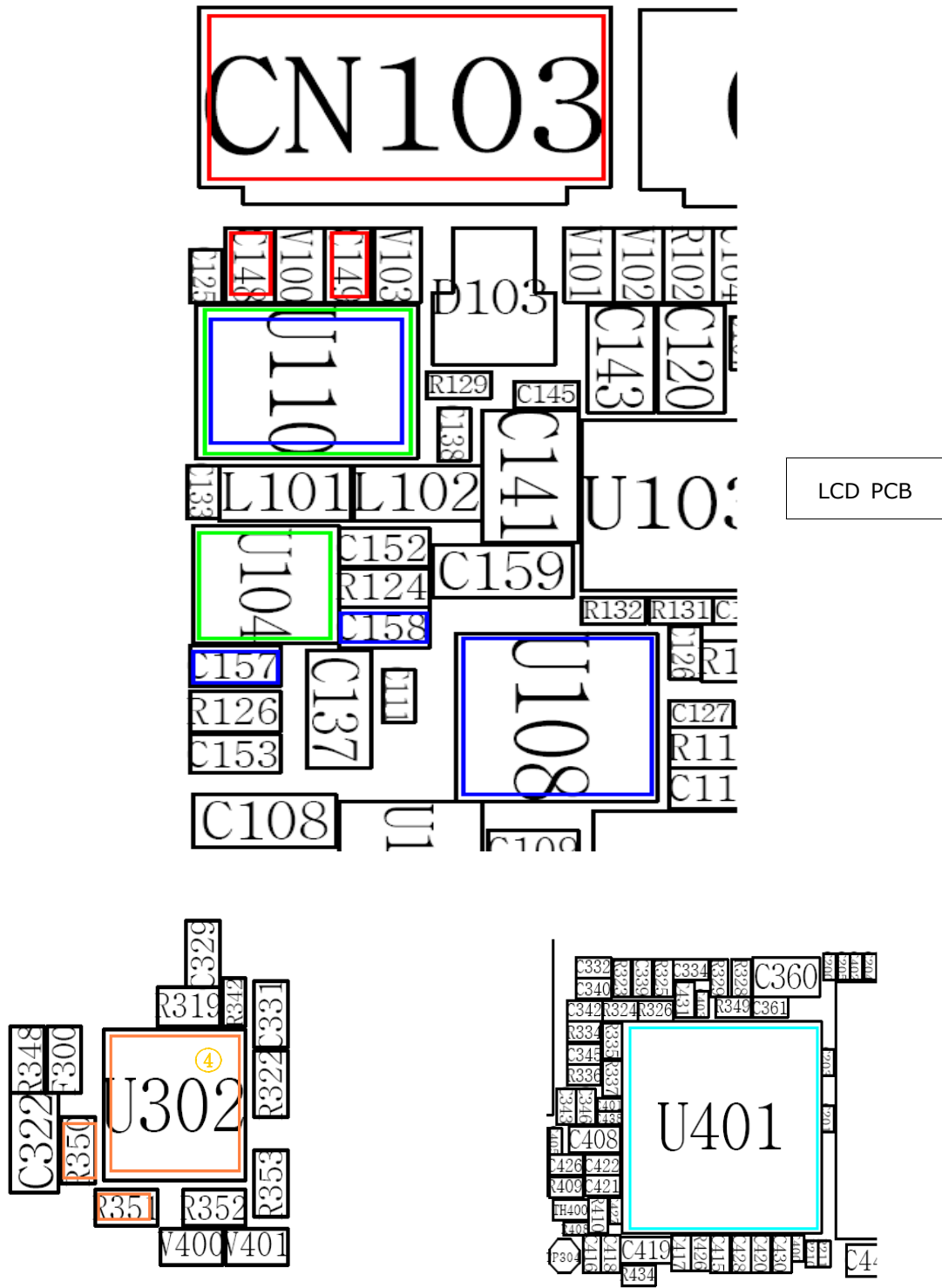

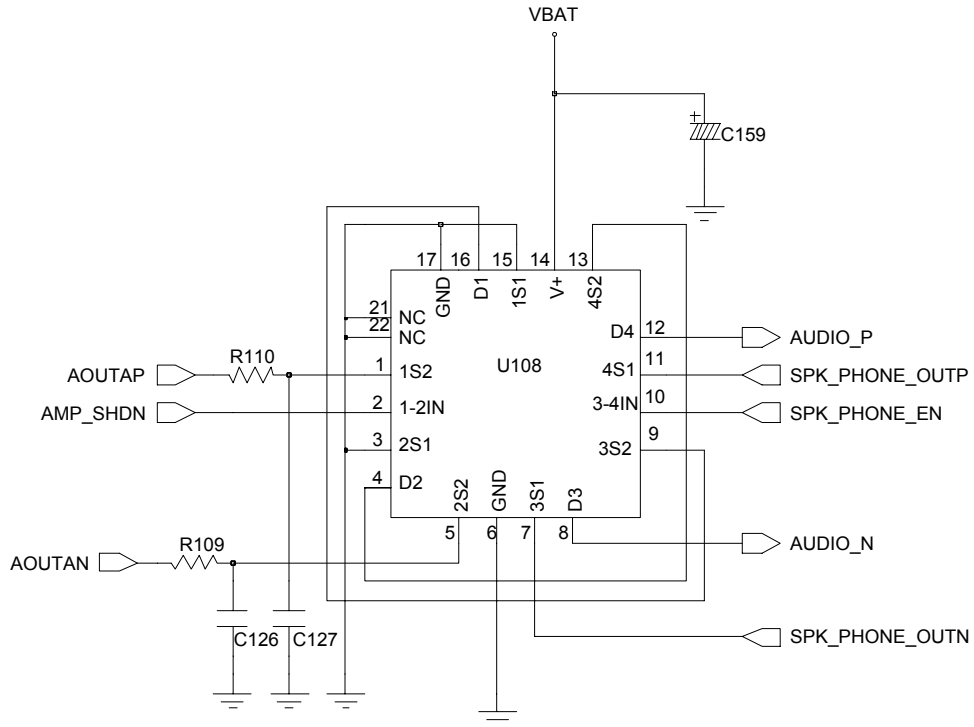
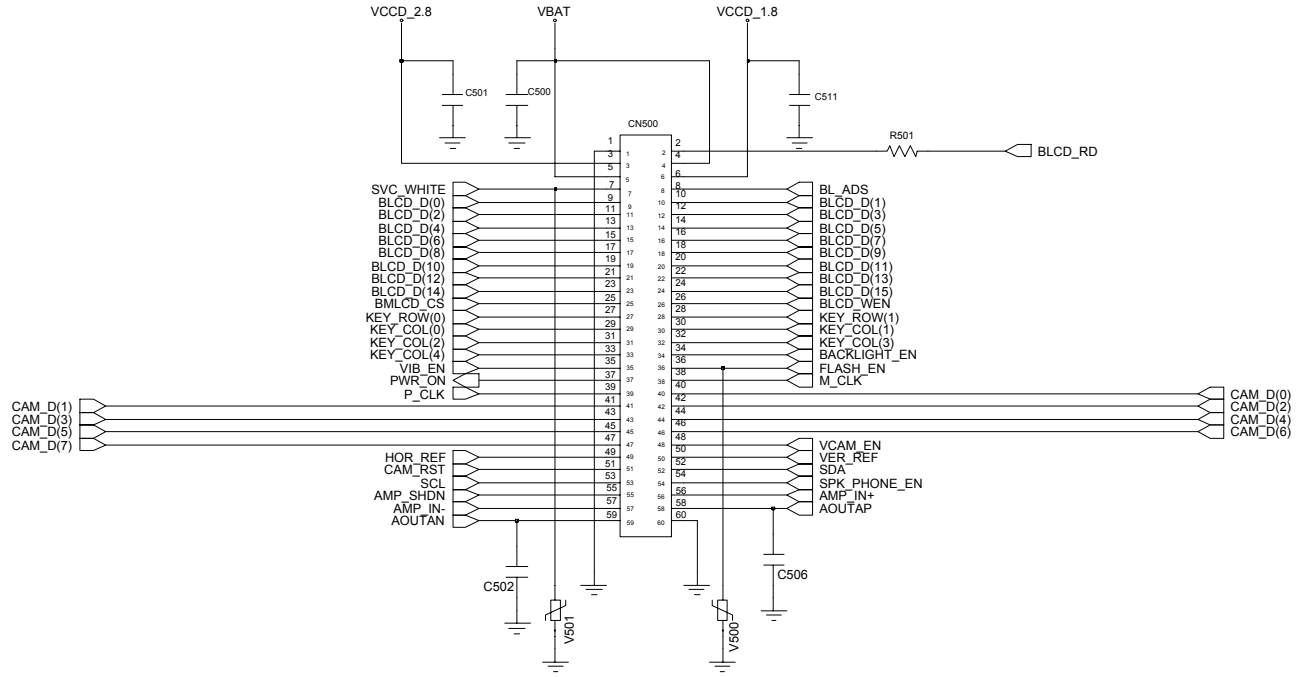

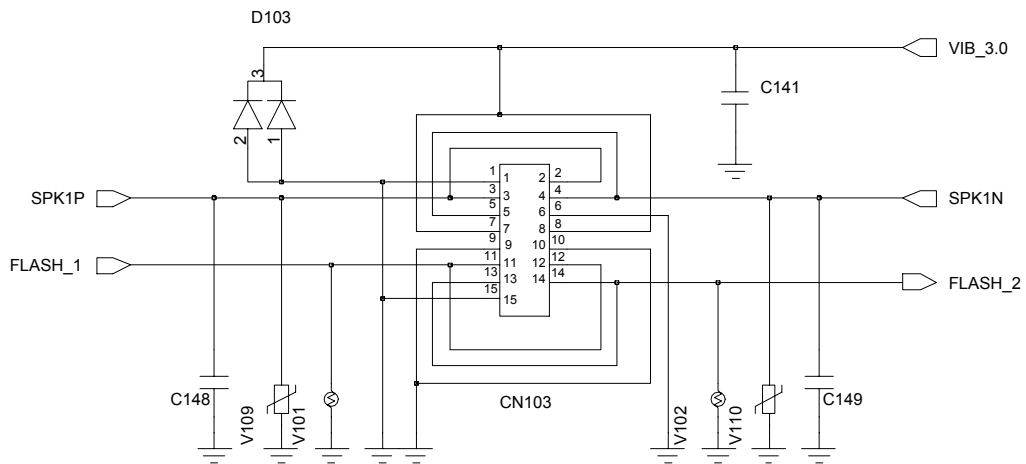
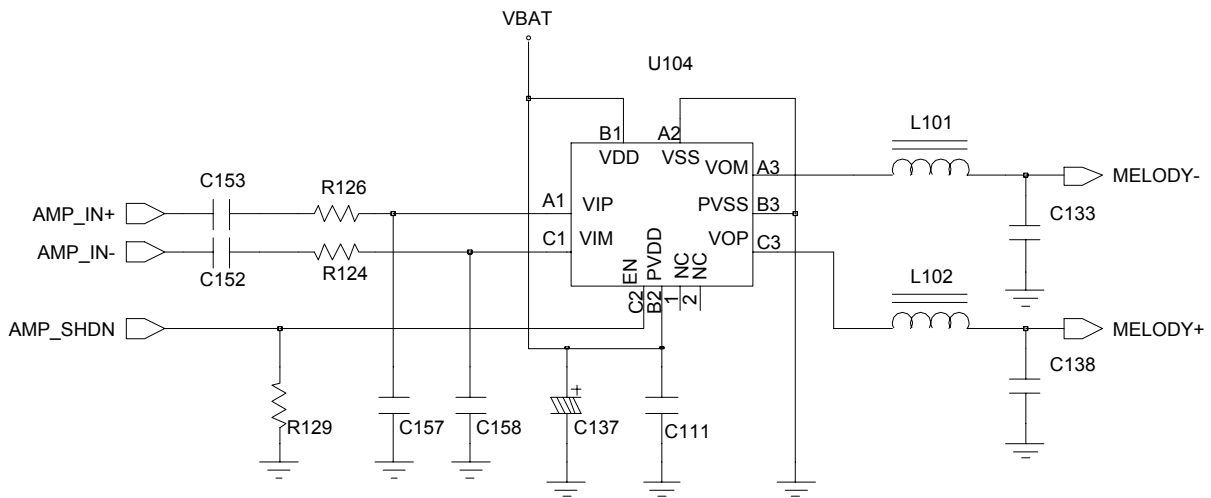
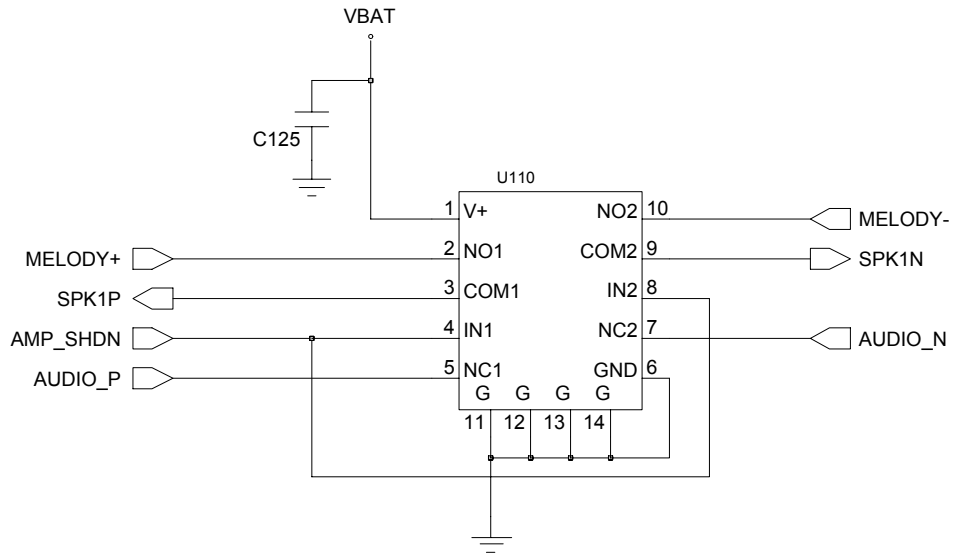

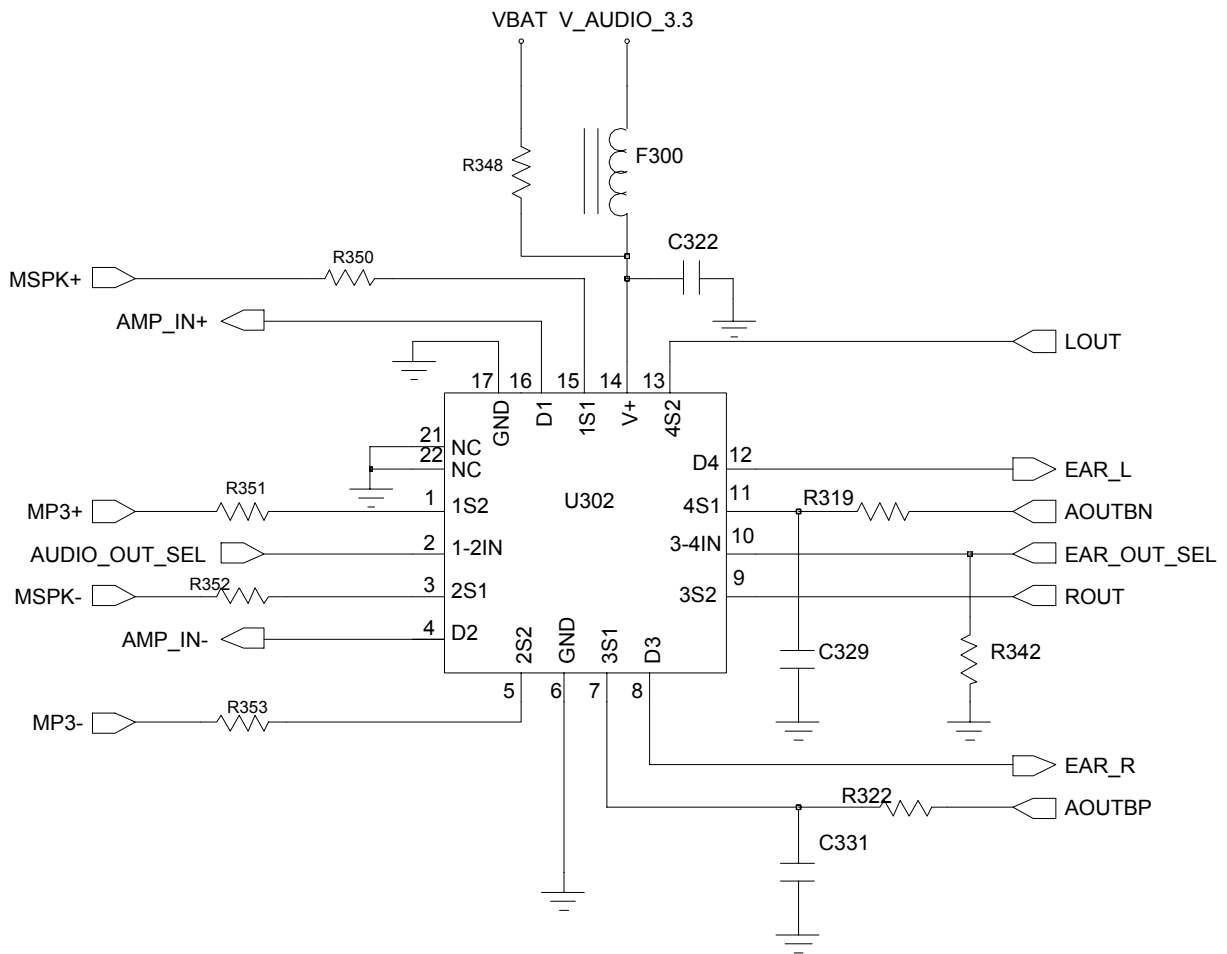

2-1-7. Camera Part

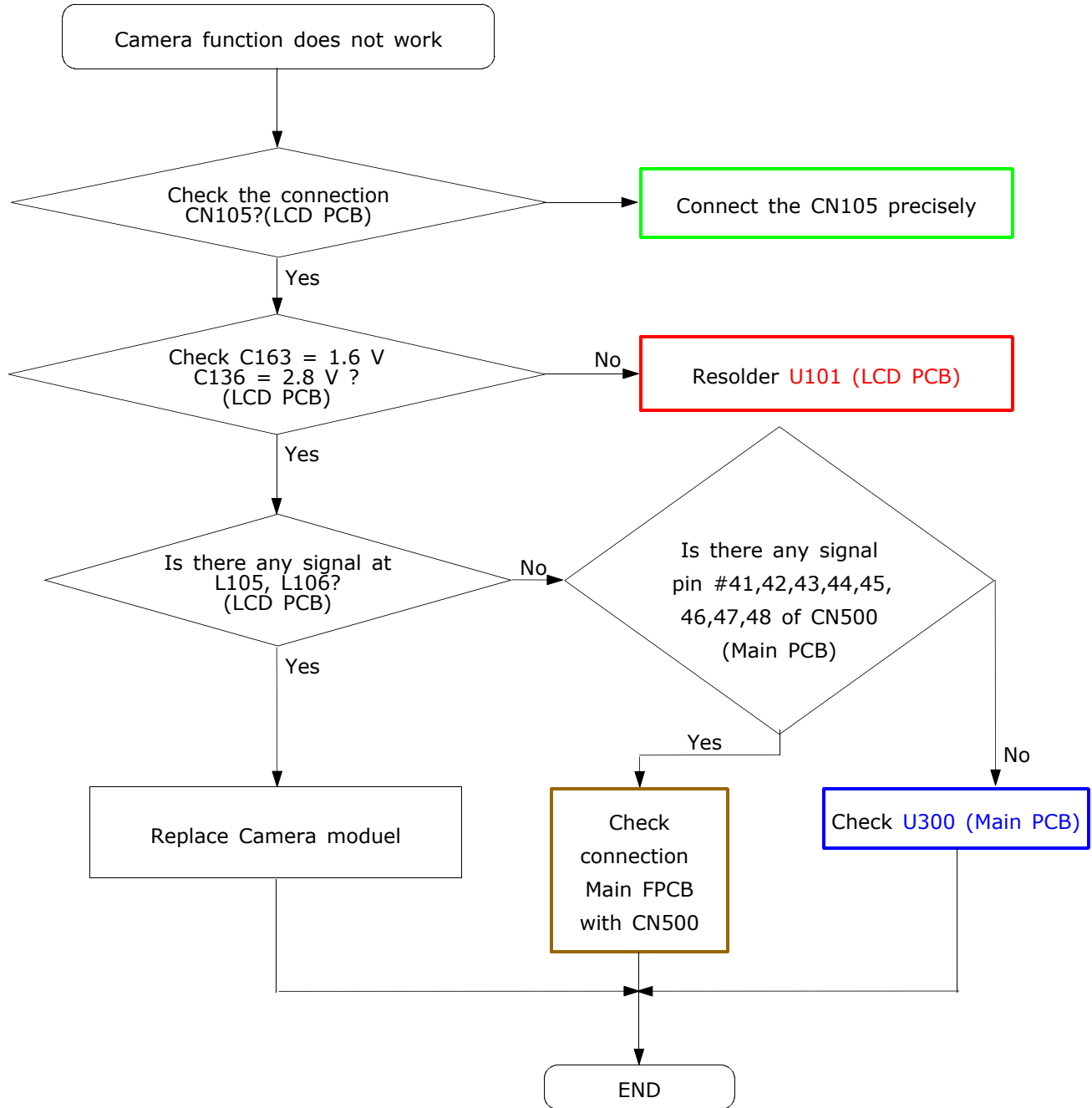

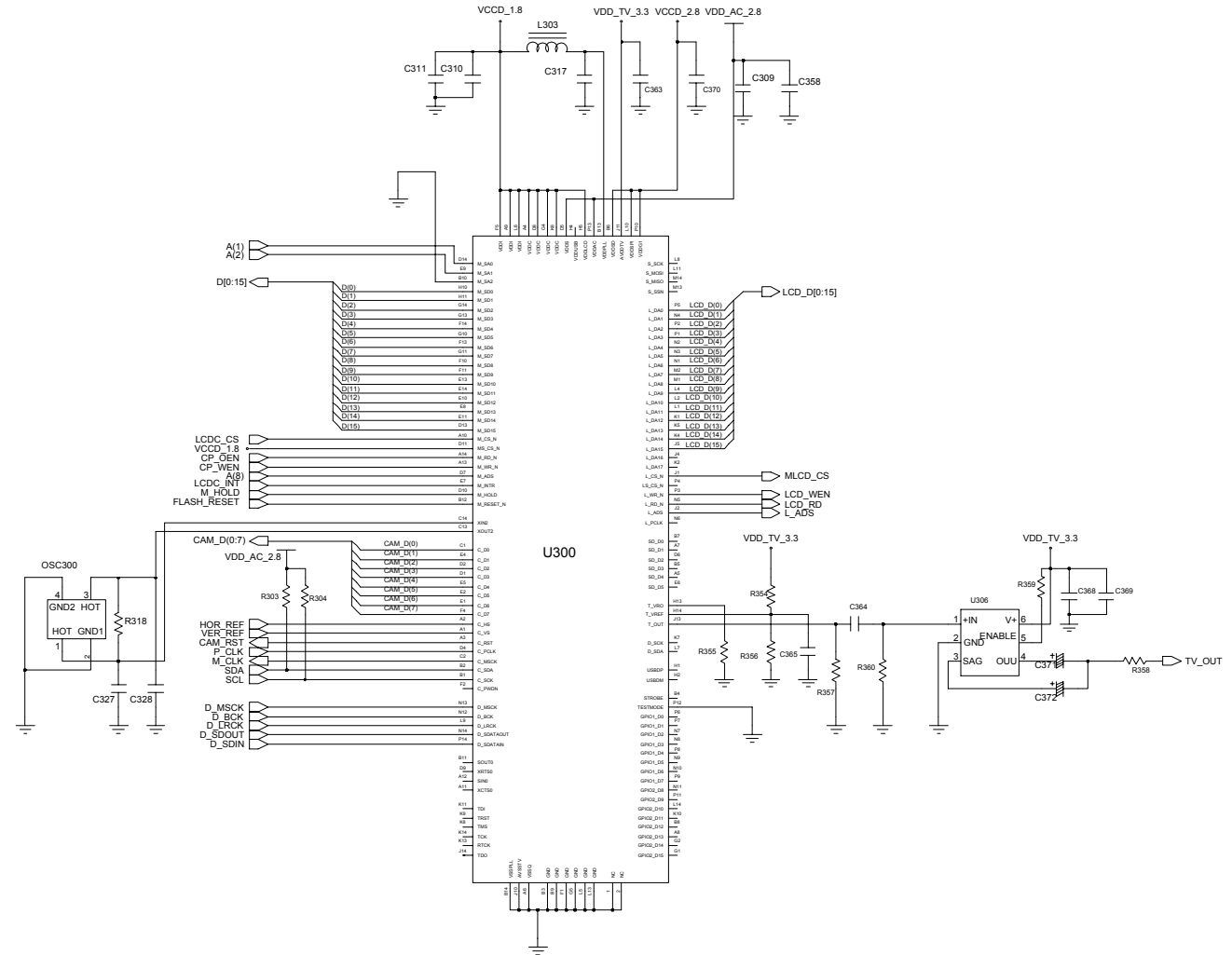

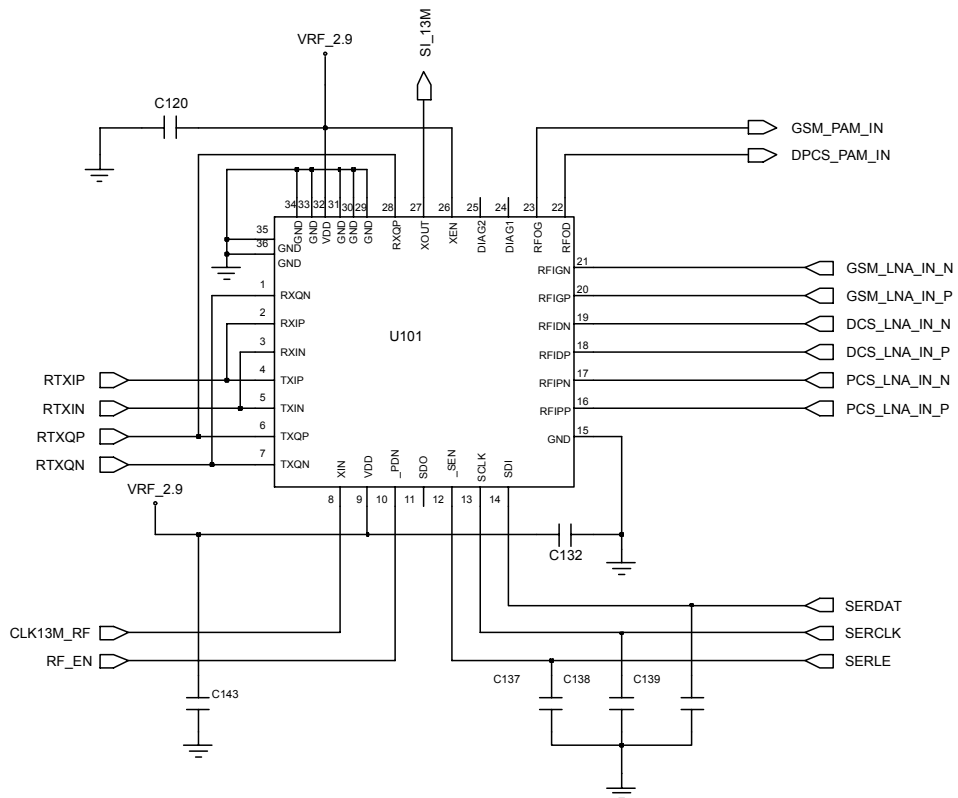
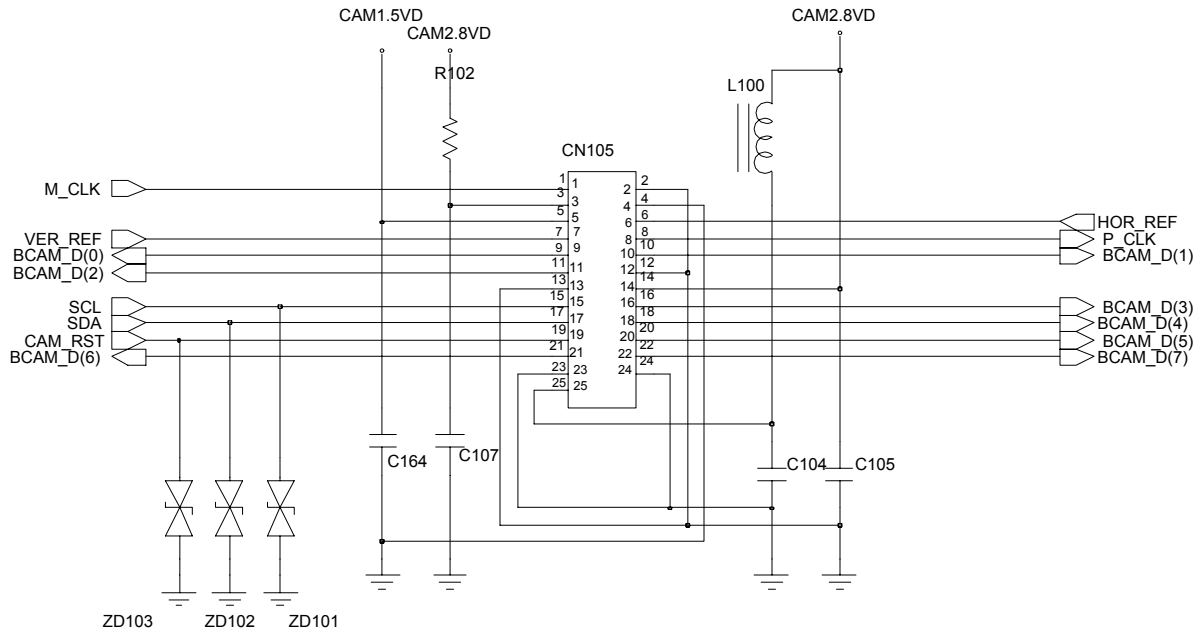

2-1-8. LCD backlight

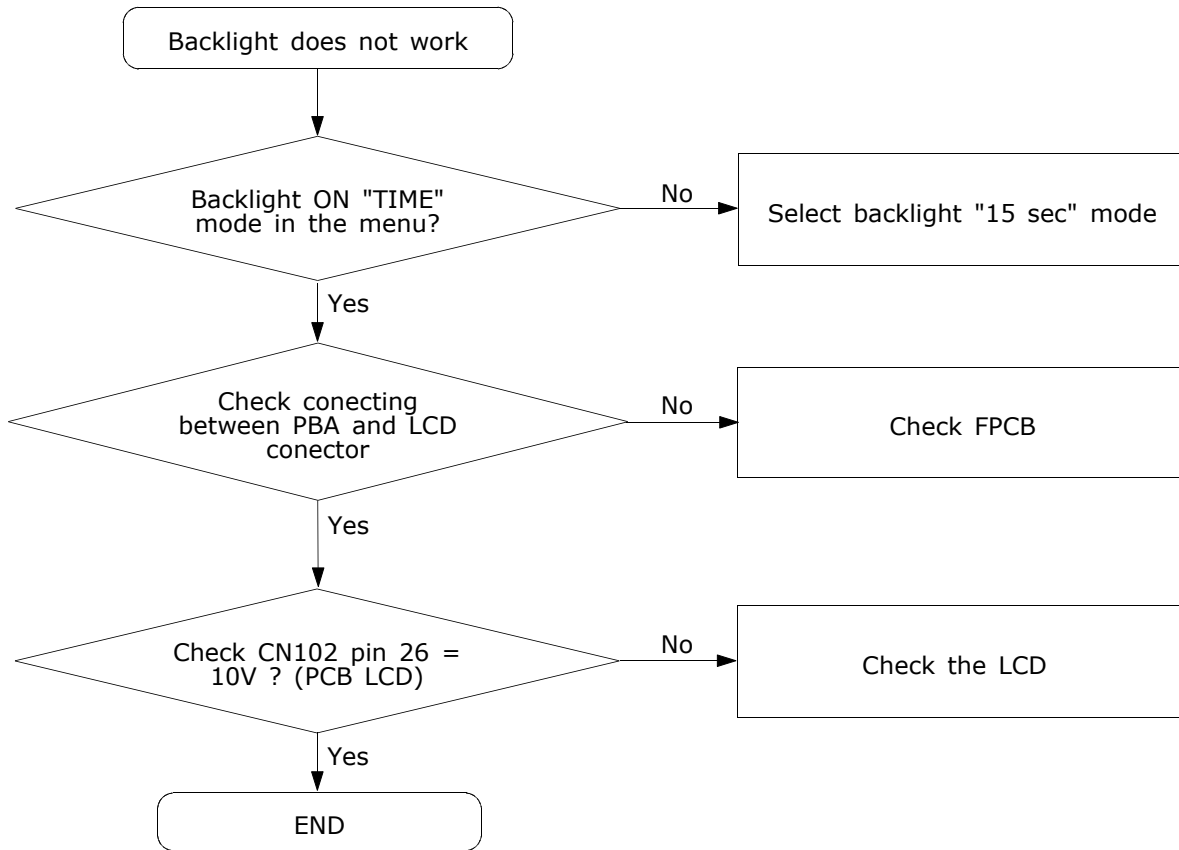

2-2 RF

2-2-1. GSM Rx

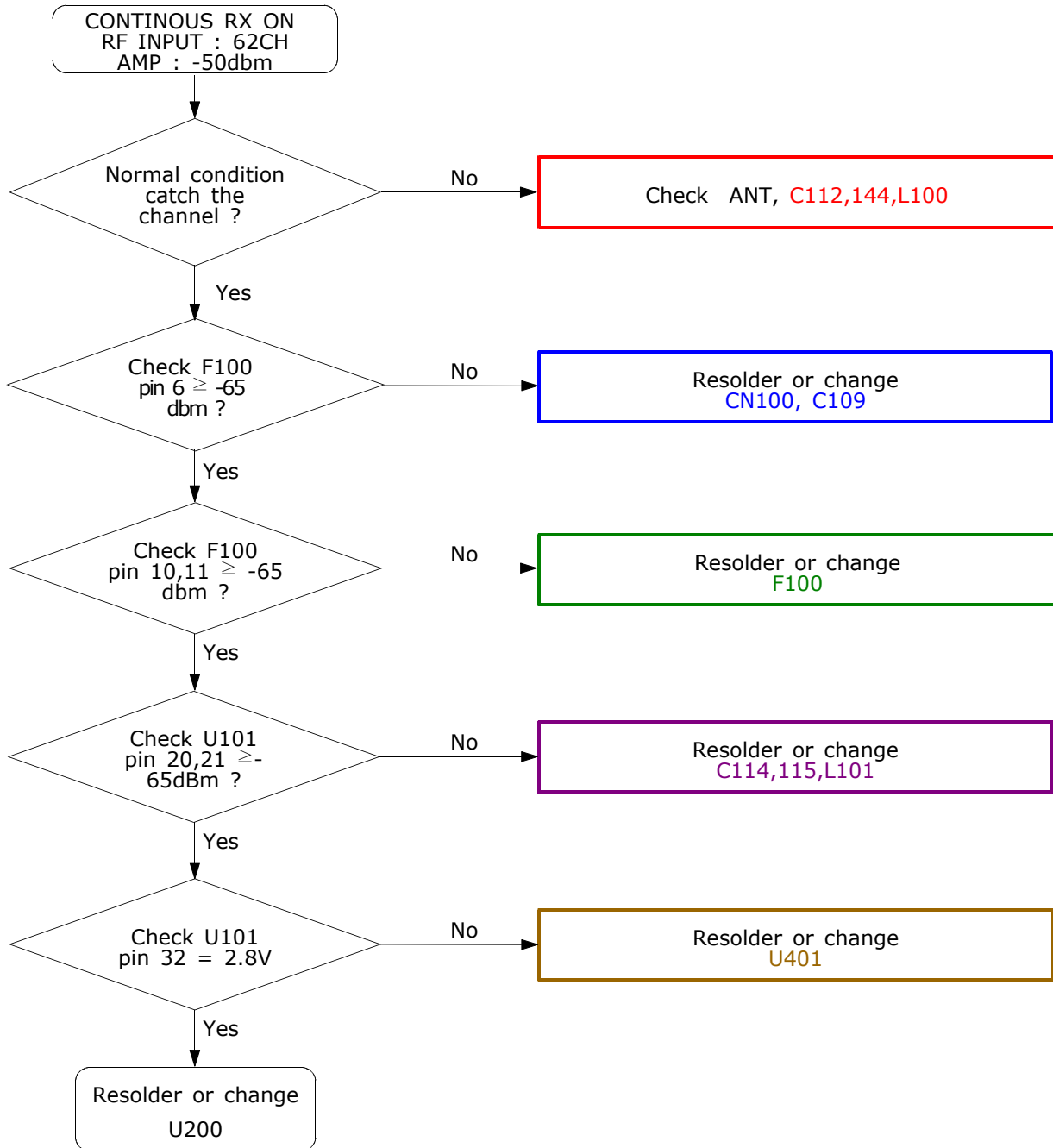

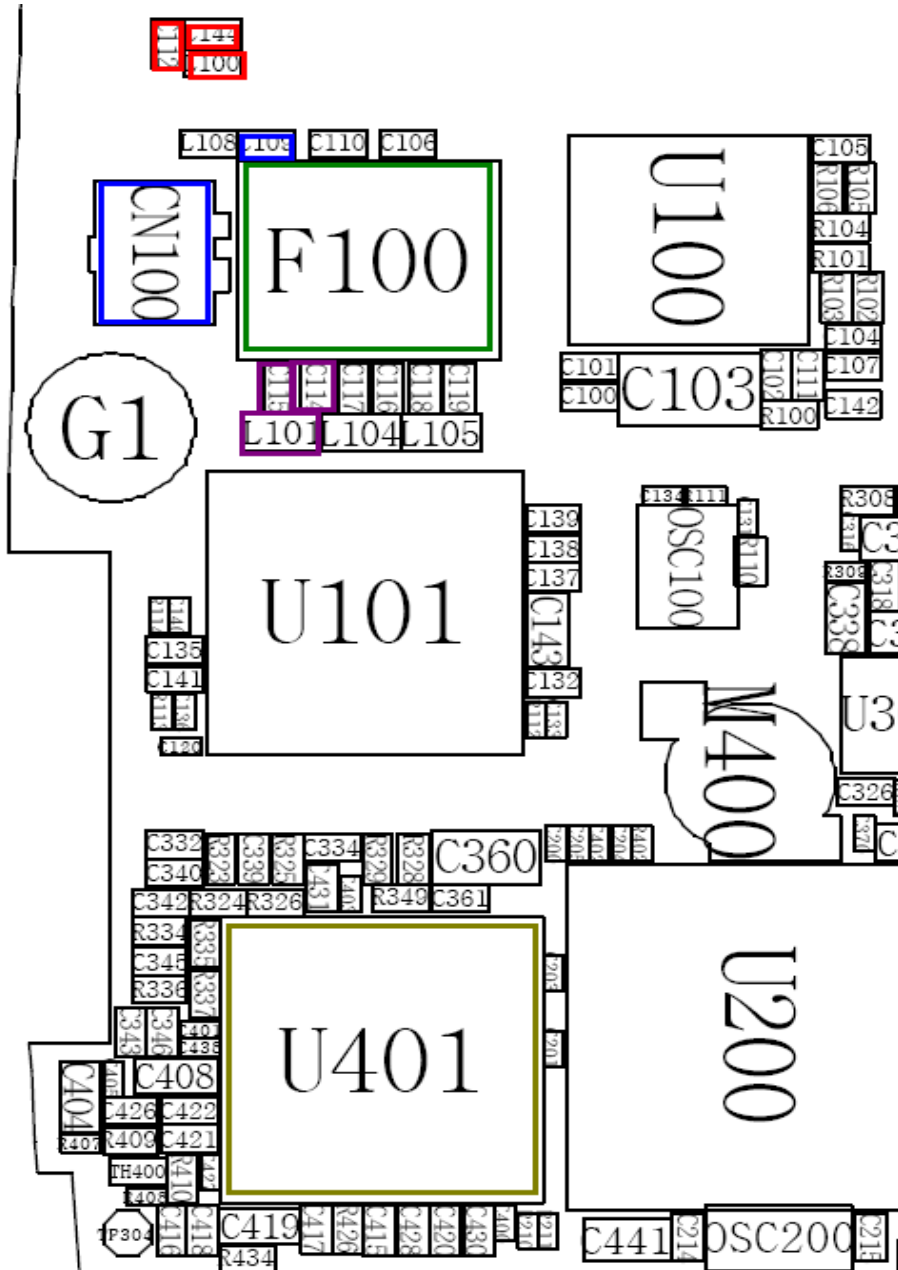

2-2-2. DCS Rx

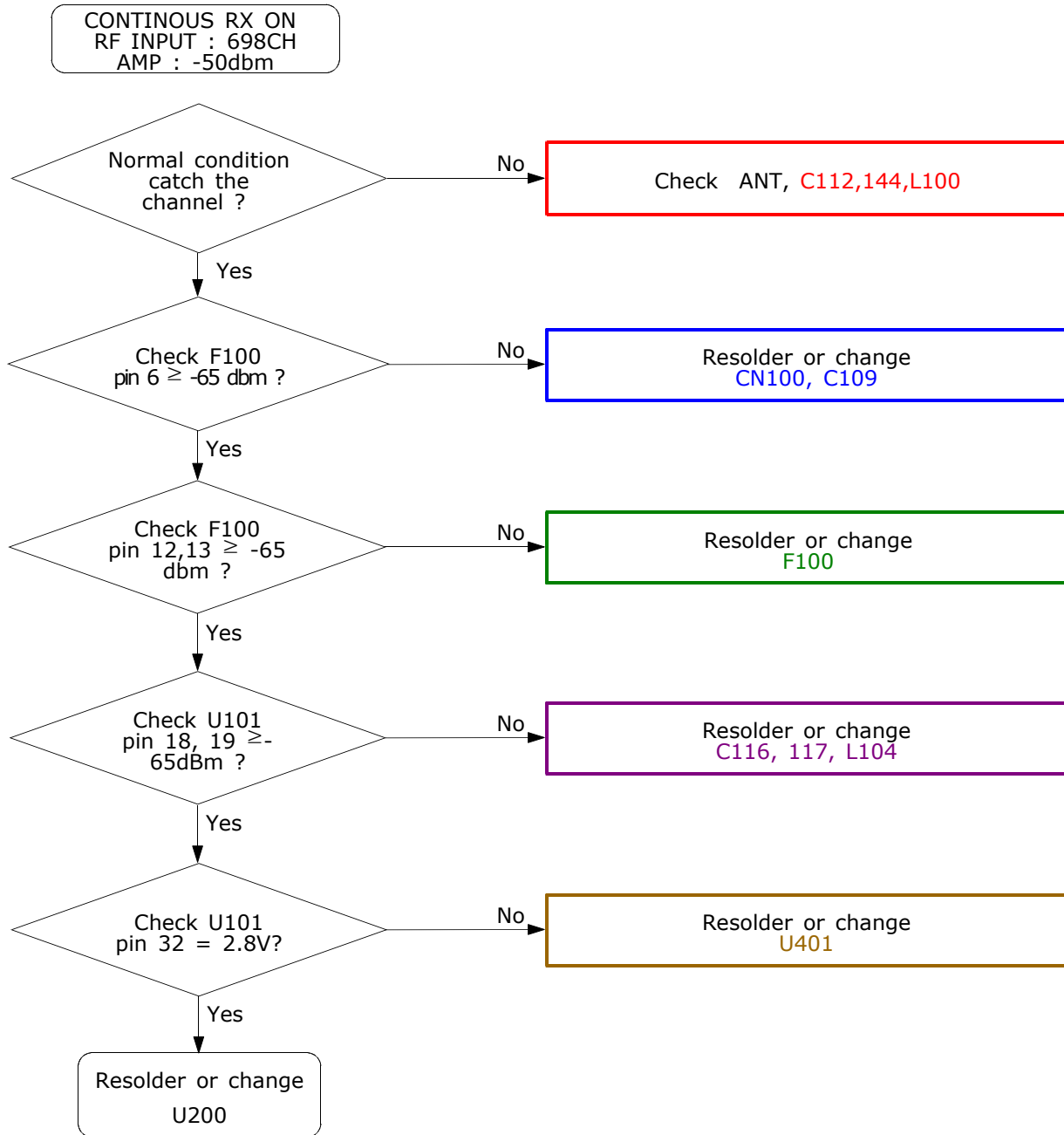

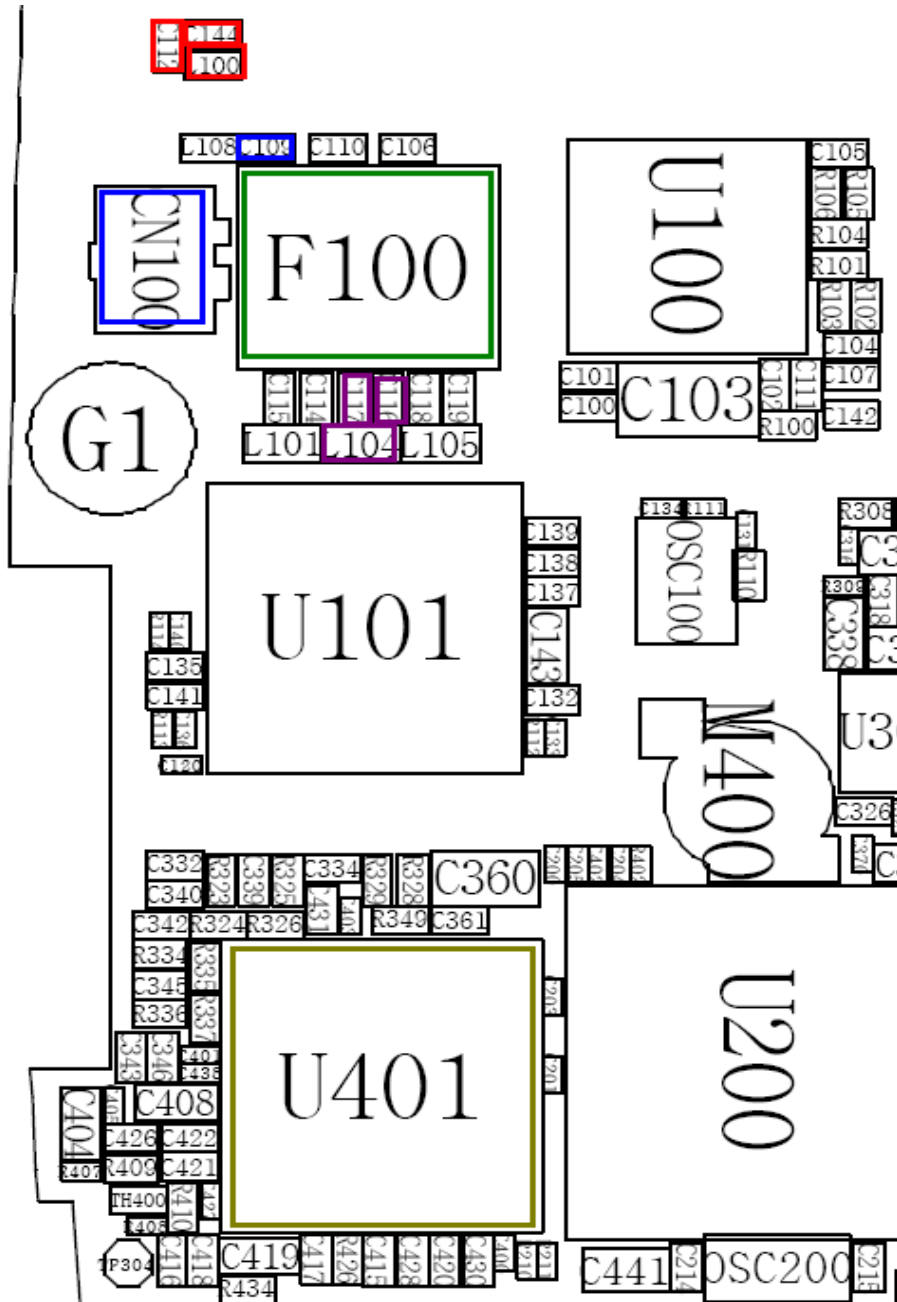

2-2-3. PCS Rx

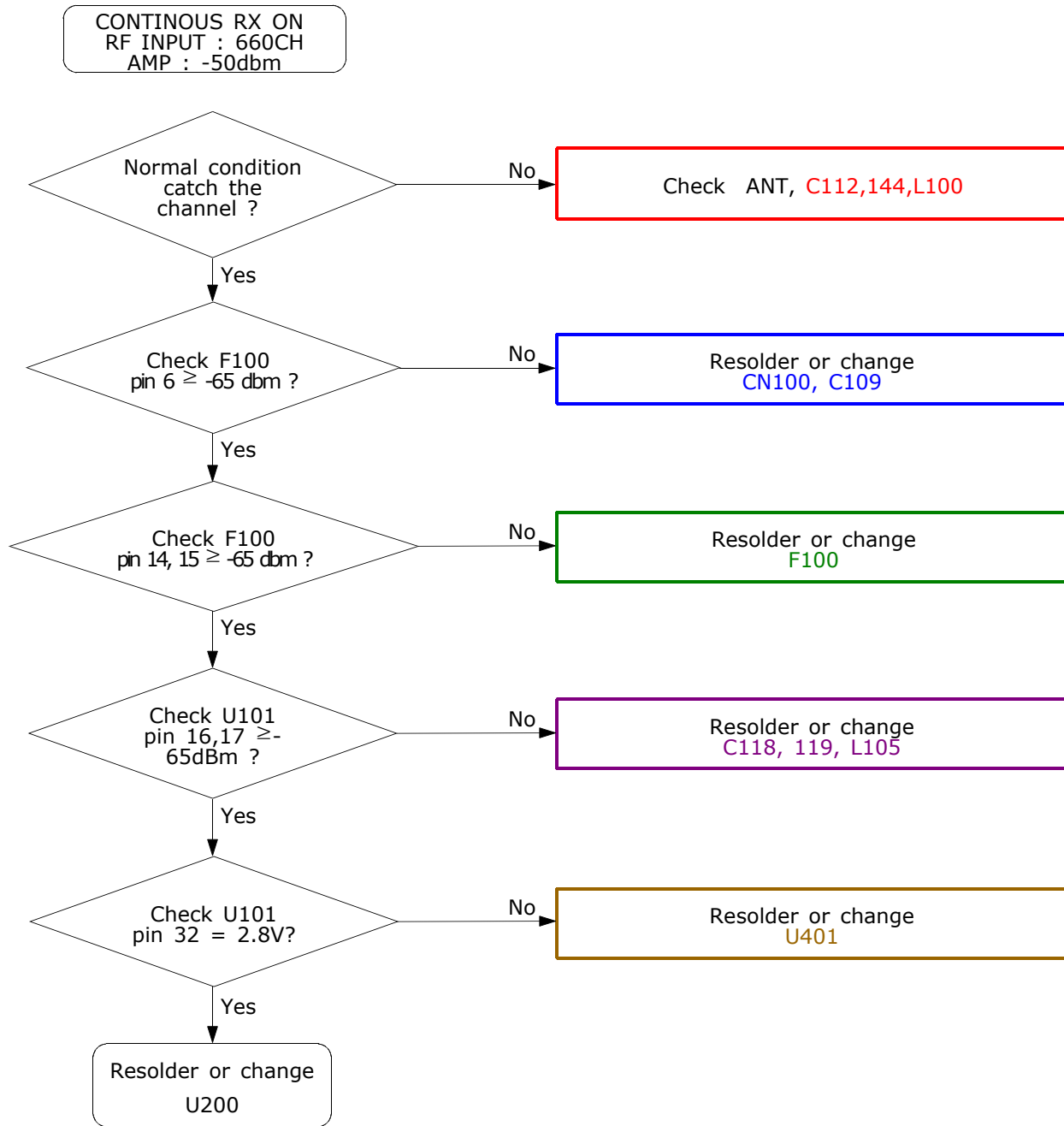

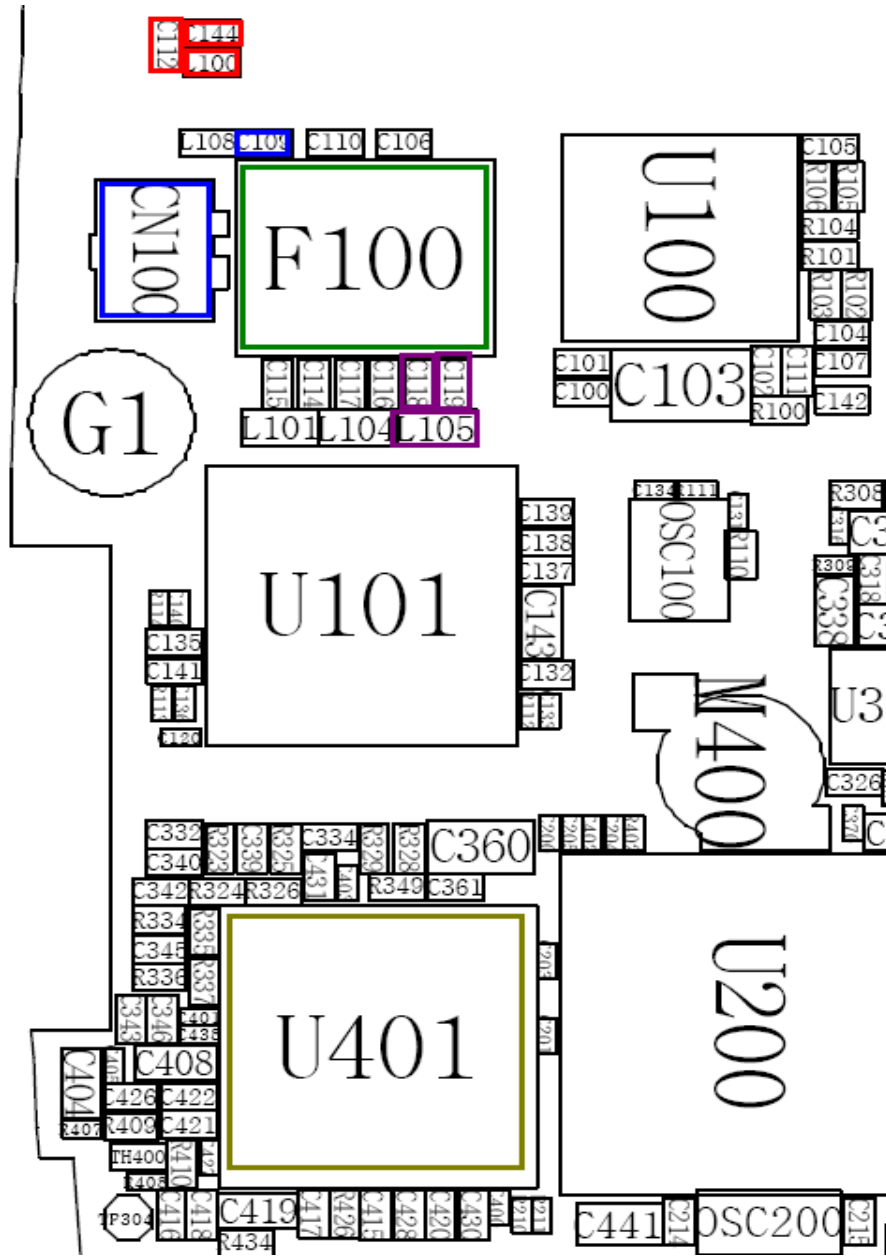

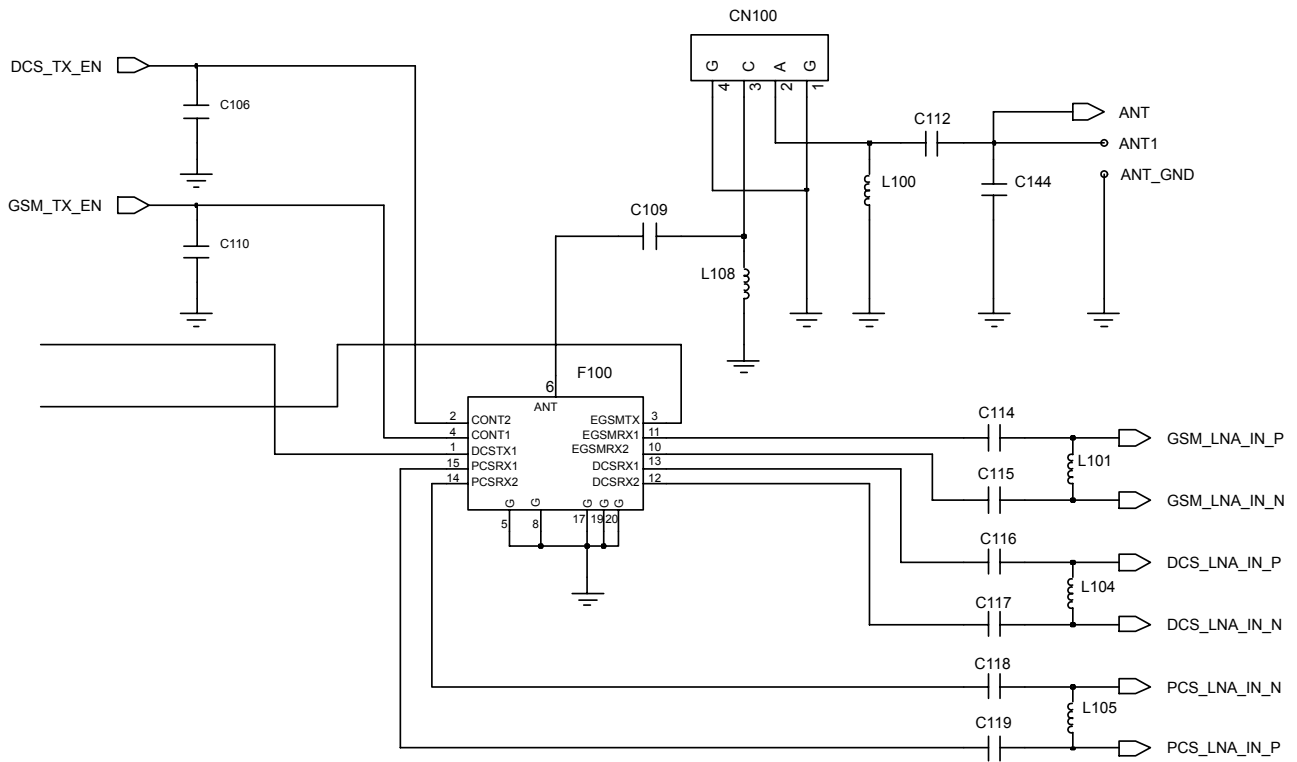

2-2-4. GSM Tx

CONTINUS TX ON CONDITION
 TX POWER DAC : 554 CODE
 APPLIED
 CH : 62ch
 RBW : 100KHz
 VBW : 100KHz
 SPAN : 10MHz
 REF LEV : 10dBm
 ATT : 20dB

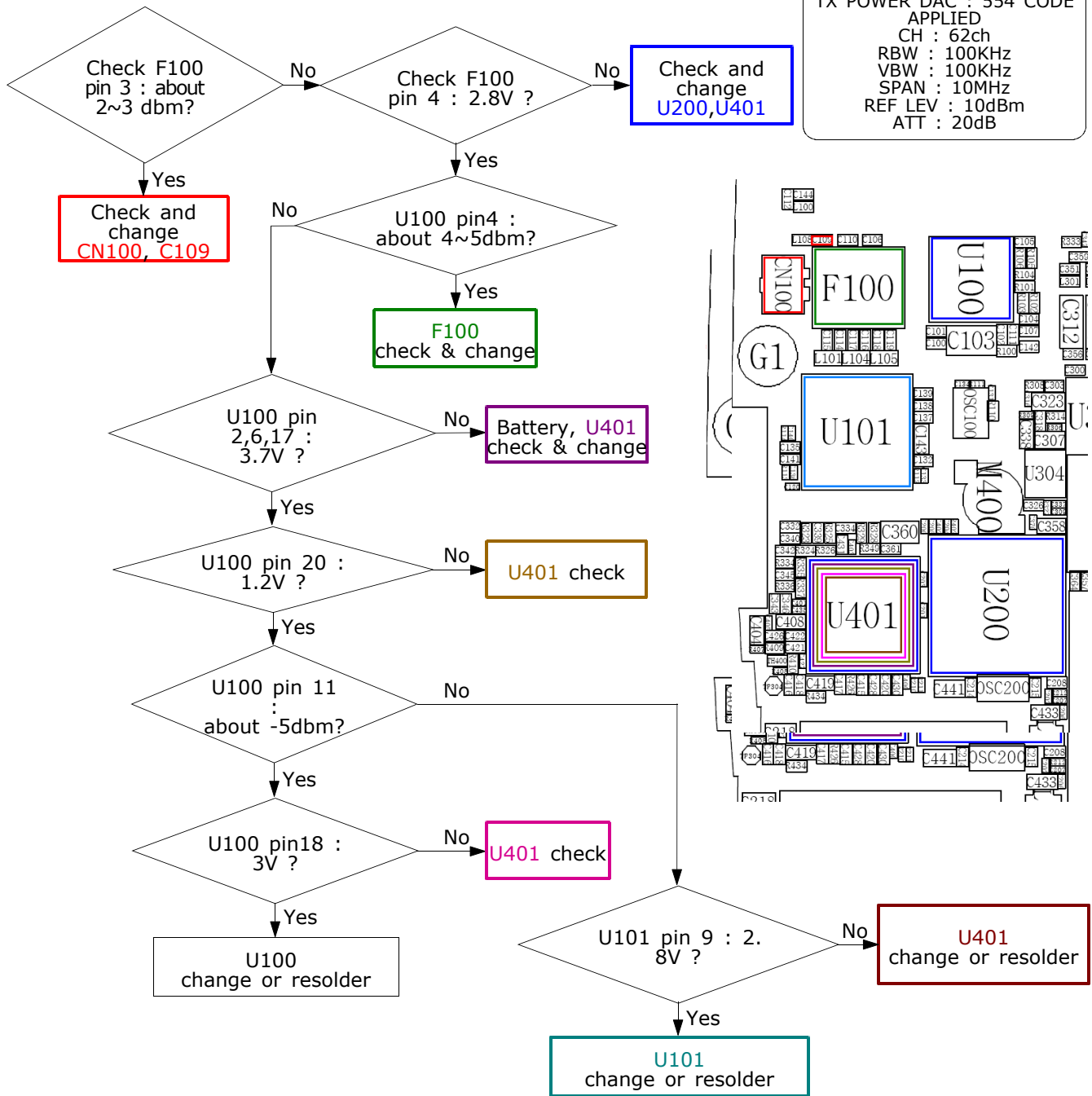

2-2-5. DCS/PCS Tx

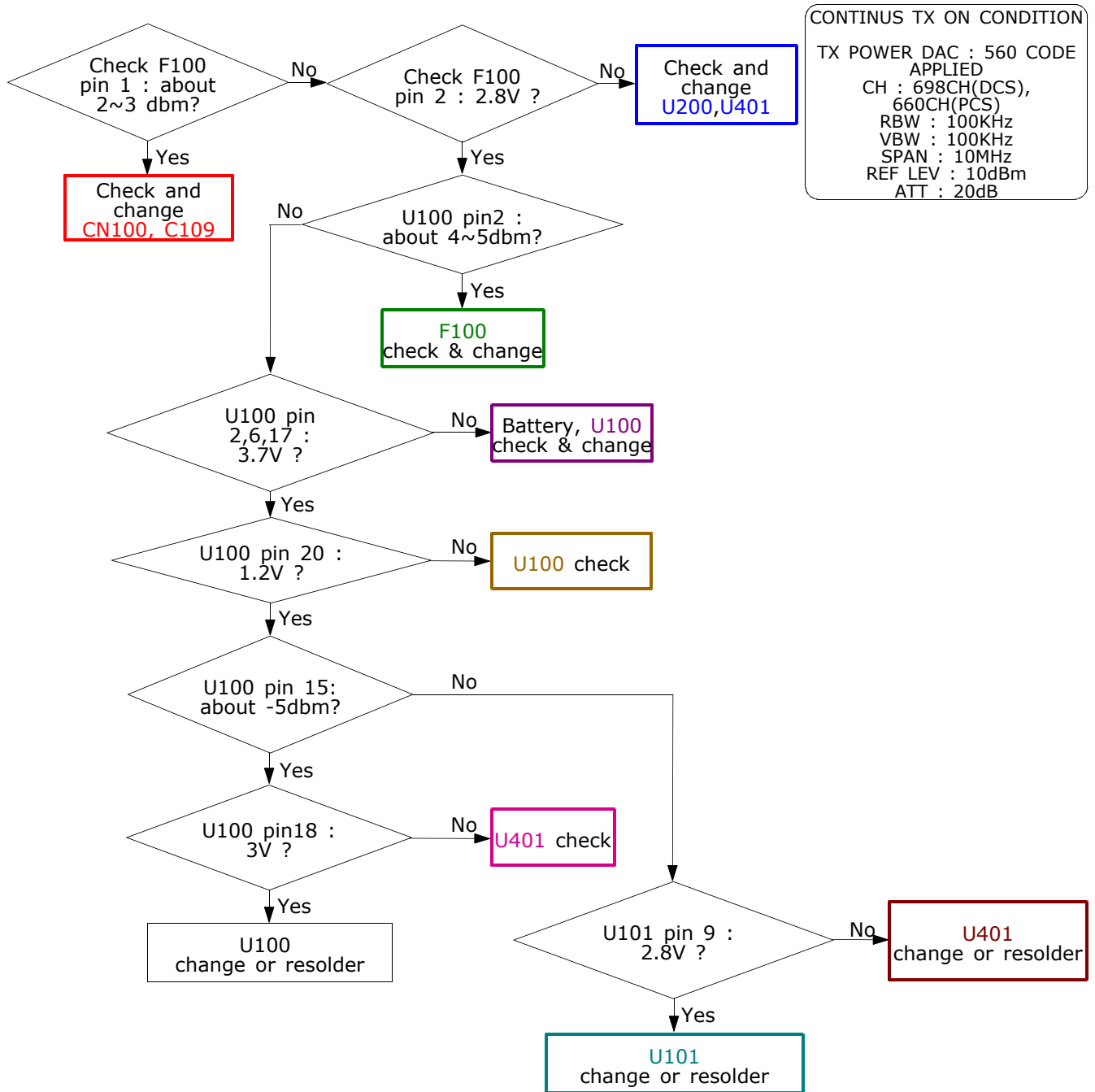

3. SGH-E860V Exploded View and Parts List

3-1. Cellular phone Exploded View

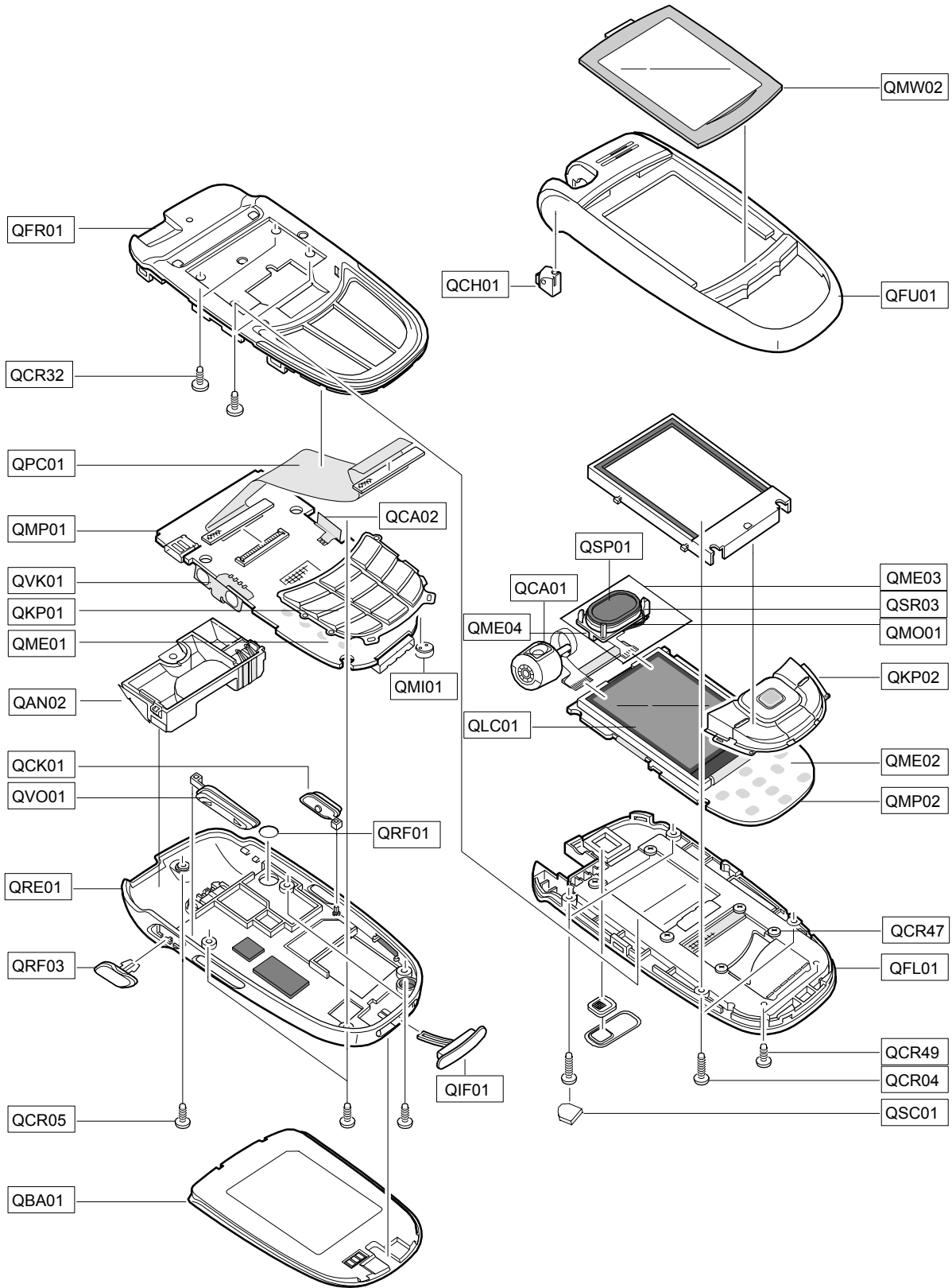

3-2. Cellular phone Parts list

Location NO.		Description	SEC CODE
QAN02		ANTENNA-SGHE860V;IAPT0GDP3918HA,SGH-	GH42-00566A
QBA01		BATTERY-800MAH,D/GRY,EU,M;BST4098DV,	GH43-01839A
QCA02		UNIT-CAMERA KEY;SGH-E860,9SK9578-010	GH59-01982A
QCR05		SCREW-MACHINE;PH,+,M1.4,L3,ZPC(BLK),	6001-001478
QIF01		PMO-IF COVER;SGH-E860,PC+PUR,VIO,-,-	GH72-19171A
QME01		UNIT-METAL DOME(MAIN);SGH-E860V,9KW9	GH59-01979A
QMI01		MICROPHONE-ASSY;2,130~500uA,-42dB,2.	GH30-00180A
QMP01		PBA MAIN-SGH-E860V;SGH-E860V,XEG,GER	GH92-02004A
QRF01		MPR-RF COVER TAPE;SGH-E860,PC SHEET,	GH74-12622A
QVK01		UNIT-SIDE KEY;SGH-E860V,9SK9578-0100	GH59-01981A
QRE01		MEC-REAR COVER;SGH-E860,VODA,PC,-,VI	GH75-06184A
	QCK01	MEC-KEY CAMERA;SGH-E865,T-MOBILE,ABS	GH75-06277A
	QRF03	PMO-EARJACK COVER 1;SGH-E860V,ABS+UR	GH72-23207A
	QVO01	MEC-KEY VOLUME;SGH-E865,T-MOBILE,ABS	GH75-06276A
QCR04		SCREW-MACHINE;PH,+,M1.4,L4,NYLOK,SWR	6001-001479
QCR32		SCREW-MACHINE;CH,+,M1.4,L2,ZPC(BLK),	6001-001700
QPC01		PCB-FPCB;SGH-E860V,POLYIMIDE,3L,-,-,	GH41-00850A
QCA01		UNIT-CAMERA;SGH-E860V,IC03044AA,-,EU	GH59-01984A
QME03		UNIT-FLASH FPCB;SGH-E860V,KBSGHE860V	GH59-01992A
	QSR03	PMO-SPEAKER HOUSING;SGH-E865,PC,SIL,	GH72-19401A
	QSP01	AS-SPEAKER;SGH-E860V,SM1318B06G,-,SP	GH81-02139A
	QMO01	AS-MOTOR;SGH-E860V,DMJBRK20LI,-,MOTO	GH81-02140A
	QME04	AS-FLASH FPCB;SGH-E860V,KBSGHE860VSF	GH81-02141A
QMW02		PMO-MAIN LCD WINDOW;SGH-E865,ACRYL,T	GH72-19301A
QSC01		RMO-S/U SCREW CAP;SGH-E860V,URETHAN,	GH73-04984A
QCH01		MEC-CAMERA HINGE;SGH-E865,T-MOBILE,P	GH75-06280A
QFR01		MEC-FRONT COVER;SGH-E860,VODA,PC,-,V	GH75-06183A
QFU01		MEC-SLIDE UPPER;SGH-E860V,VODA,EU,-,	GH75-07476A
QKP01		MEC-KEYPAD MAIN;SGH-E865,T-MOBILE,PC	GH75-06283A
QKP02		MEC-KEYPAD SUB;SGH-E865,T-MOBILE,PC,	GH75-06282A
QFL01		MEC-SLIDE LOWER;SGH-E860V,VODA,EU,-,	GH75-07477A
	QCR47	SCREW-MACHINE;BH,+,M1.4,L2,ZPC(WHT),	6001-001695
	QCR49	SCREW-MACHINE;CH,+,M1.4,L2,NI PLT,SW	6001-001823
QMP02		PBA SUB-SGHE860V;SGH-E860V,VDF,EU,PB	GH92-02213A
QME02		UNIT-METAL DOME(SUB);SGH-E860V,9KW95	GH59-01980A
QLC01		ELA UNIT-SGHE860V LCD MODULE;SGH-E86	GH96-01813A

Description	SEC CODE
BAG PE;LDPE,T0.05,W80,L180,TRP,-,-	6902-000634
ADAPTOR-SGHD500 BLK;TAD137EBE,SGH-D5	GH44-00954A
S/W UTILITY-SAMSUNGPCSTUDIOII2;SGH-E	GH46-00138A
UNIT-SGHE860 BLU;SGH-E860,WYBLU ESSE	GH59-01967A
EARPHONE-STEREO EAR PHONE;SGH-D500,A	GH59-02236A
LABEL(P)-WATER SOAK;COMM,NORGE,100G,	GH68-02026A
LABEL(R)-MAIN;SGH-E860,-,MAT,T0.1,30	GH68-06867A
MANUAL-EXTENDED WARRANTY;COMM,VODAFO	GH68-06927A
MANUAL-WEEE CARD;COMM,SEC,ENGLISH,UN	GH68-07013A
MANUAL-USER;SGH-E860V,VD2,GERMAN,GER	GH68-07518A
MANUAL-QSG;SGH-E860V,VD2,GERMAN,GERM	GH68-07519A
BOX(P)-UNIT MAIN VODA;SGH-E860V,SC30	GH69-02893A
CUSHION-CASE TA2 MA1;SGH-E860V,PULP,	GH69-03208A
PMO-BATT LOCKER;SGH-E865,PC,BLU,-,-,	GH72-19397A
MPR-CAMERA INSULATION;SGH-E860,CON T	GH74-12599A
MPR-LCD FPCB SHIELD TAPE;SGH-E860,GA	GH74-12602A
MPR-MAIN FPCB TAPE;SGH-E860,CON,21X3	GH74-12604A
MPR-LCD CONN INSULATION;SGH-E860,INS	GH74-12605A
MPR-LCD DOME EMI TAPE R;SGH-E860,CON	GH74-12606A
MPR-KEYPAD EMI TAPE;SGH-E860,CON,3X8	GH74-12608A
MPR-MAIN FILTER INSULATI;SGH-E860,IN	GH74-12611A
MPR-MAIN FPCB SHIELD EMI;SGH-E860,CO	GH74-12612A
MPR-MAIN FPCB SHIELD EMI;SGH-E860,CO	GH74-12612A
MPR-CAMERA INSULATION B;SGH-E860,INS	GH74-12811A
MPR-MAIN GROUND EMI TAPE;SGH-E860,CO	GH74-12813A
MPR-FPCB LCD INSULATION;SGH-E860,INS	GH74-12814A
MPR-TAPE FPCB A;SGH-E865,TESA 4959,4	GH74-13729A
MPR-TAPE FPCB B;SGH-E865,DTF104,20X1	GH74-13737A
MPR-REMOVE TAPE LCD;SGH-E865,3M PET,	GH74-13804A
MPR-BOHO VINYL S/U 1;SGH-E860V,SP-60	GH74-15915A
MPR-BOHO VINYL S/U 2;SGH-E860V,SP-60	GH74-15916A
MPR-BOHO VINYL WINOW 1;SGH-E860V,ELE	GH74-15917A
MPR-BOHO VINYL WINOW 2;SGH-E860V,3M	GH74-15918A
MPR-LCD DOME EMI TAPE R;SGH-E860V,DT	GH74-16891A
MPR-TAPE LED INSULATION;SGH-E860V,PE	GH74-16894A
MEC-HANGER;SGH-Z500,TMN,STRAP,-,BLK,	GH75-03673H
MEC-SUB SLIDE LOWER;SGH-E860V,VODA,E	GH75-07479A

3-3. Test Jig (GH80-00865A)

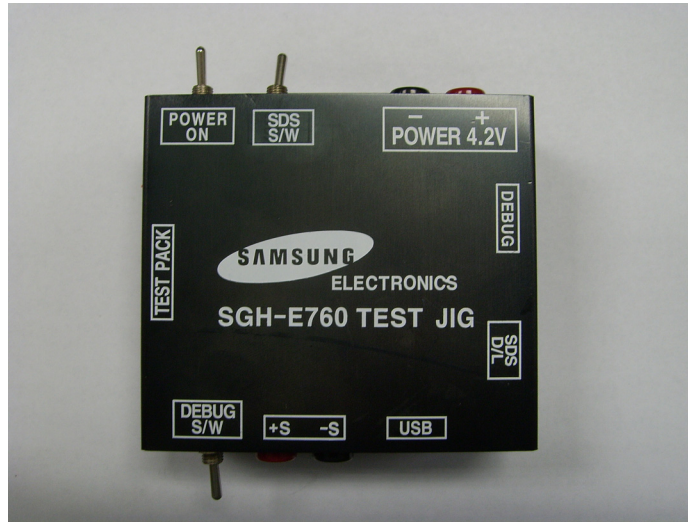

3-3-1. RF Test Cable
(GH39-00283A)



3-3-2. Test Cable
(GH39-00127A)



3-3-3. Serial Cable



3-3-4. Power Supply Cable

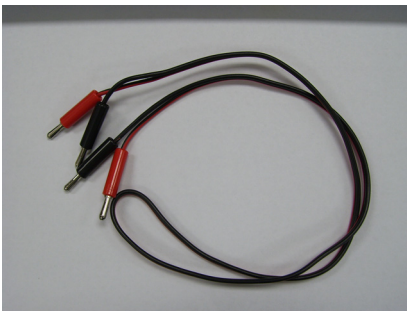

3-3-5. DATA CABLE
(GH39-00331A)

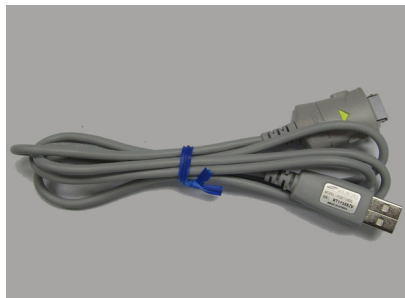

3-3-6. TA
(GH44-00954A)



4. SGH-E860V MAIN Electrical Parts List

4-1. Main

SEC Code	Design LOC	Discription	SEC Code	Design LOC	Discription
0403-001387	ZD504	DIODE-ZENER	2203-000438	C351	C-CER,CHIP
0403-001427	ZD505	DIODE-ZENER	2203-000438	C352	C-CER,CHIP
0406-001150	V406	DIODE-TVS	2203-000438	C425	C-CER,CHIP
0406-001150	V407	DIODE-TVS	2203-000812	C111	C-CER,CHIP
0406-001150	V408	DIODE-TVS	2203-000812	C142	C-CER,CHIP
0406-001150	ZD301	DIODE-TVS	2203-000812	C502	C-CER,CHIP
0406-001150	ZD302	DIODE-TVS	2203-000812	C506	C-CER,CHIP
0406-001150	ZD500	DIODE-TVS	2203-000854	C329	C-CER,CHIP
0406-001150	ZD501	DIODE-TVS	2203-000854	C331	C-CER,CHIP
0504-001171	Q500	TR-DIGITAL	2203-000854	C339	C-CER,CHIP
0601-001819	LED400	LED	2203-000854	C340	C-CER,CHIP
0601-001819	LED401	LED	2203-000854	C345	C-CER,CHIP
0601-001819	LED402	LED	2203-000854	C346	C-CER,CHIP
0601-001819	LED403	LED	2203-000885	C318	C-CER,CHIP
0601-001819	LED404	LED	2203-000995	C217	C-CER,CHIP
0601-001819	LED405	LED	2203-001153	C109	C-CER,CHIP
0601-001819	LED406	LED	2203-001153	C410	C-CER,CHIP
0601-001819	LED407	LED	2203-001210	C413	C-CER,CHIP
0601-001819	LED408	LED	2203-001259	C112	C-CER,CHIP
0601-001819	LED409	LED	2203-001405	C132	C-CER,CHIP
0604-001291	U202	PHOTO-IRDA	2203-001405	C426	C-CER,CHIP
0801-002529	U500	IC-CMOS LOGIC	2203-005061	C107	C-CER,CHIP
1001-001261	U301	IC-ANALOG SWITCH	2203-005061	C317	C-CER,CHIP
1001-001306	U302	IC-ANALOG MULTIPLEX	2203-005061	C430	C-CER,CHIP
1006-001313	U403	IC-BUS TRANSCEIVER	2203-005234	C114	C-CER,CHIP
1009-001018	U203	IC-HALL EFFECT S/W	2203-005234	C115	C-CER,CHIP
1108-000024	U201	IC-MCP	2203-005234	C116	C-CER,CHIP
1201-002218	U100	IC-POWER AMP	2203-005234	C117	C-CER,CHIP
1203-003109	U501	IC-BATTERY	2203-005234	C119	C-CER,CHIP
1203-003169	U304	IC-MULTI REG.	2203-005288	C118	C-CER,CHIP
1203-003428	U404	IC-DC/DC CONVERTER	2203-005496	C319	C-CER,CHIP
1203-003432	U103	IC-POSI.FIXED REG.	2203-005496	C320	C-CER,CHIP
1203-003434	U405	IC-DC/DC CONVERTER	2203-005571	C435	C-CER,CHIP
1203-003565	U401	IC-POWER SUPERVISOR	2203-005682	C406	C-CER,CHIP
1203-003754	U402	IC-POSI.FIXED REG.	2203-005682	C407	C-CER,CHIP
1204-002138	U400	IC-MELODY	2203-005682	C409	C-CER,CHIP

SEC Code	Design LOC	Discription	SEC Code	Design LOC	Discription
1205-002433	U101	IC-TRANSCEIVER	2203-005729	C140	C-CER,CHIP
1205-002613	U303	IC-CODEC	2203-005736	C136	C-CER,CHIP
1205-002746	U300	IC-CODEC	2203-006053	C322	C-CER,CHIP
1404-001165	TH400	THERMISTOR-NTC	2203-006053	C325	C-CER,CHIP
1405-001082	V300	VARISTOR	2203-006053	C404	C-CER,CHIP
1405-001082	V302	VARISTOR	2203-006053	C419	C-CER,CHIP
1405-001082	V303	VARISTOR	2203-006053	C440	C-CER,CHIP
1405-001082	V305	VARISTOR	2203-006053	C500	C-CER,CHIP
1405-001082	V306	VARISTOR	2203-006053	C511	C-CER,CHIP
1405-001082	V307	VARISTOR	2203-006093	C128	C-CER,CHIP
1405-001082	V400	VARISTOR	2203-006093	C300	C-CER,CHIP
1405-001082	V401	VARISTOR	2203-006093	C301	C-CER,CHIP
1405-001082	V402	VARISTOR	2203-006093	C303	C-CER,CHIP
1405-001082	V403	VARISTOR	2203-006093	C321	C-CER,CHIP
1405-001082	V404	VARISTOR	2203-006093	C326	C-CER,CHIP
1405-001082	V405	VARISTOR	2203-006093	C332	C-CER,CHIP
1405-001082	V500	VARISTOR	2203-006093	C334	C-CER,CHIP
1405-001082	V501	VARISTOR	2203-006093	C355	C-CER,CHIP
1405-001082	V502	VARISTOR	2203-006093	C356	C-CER,CHIP
1405-001082	V503	VARISTOR	2203-006093	C415	C-CER,CHIP
1405-001082	V504	VARISTOR	2203-006093	C416	C-CER,CHIP
1405-001082	V505	VARISTOR	2203-006093	C417	C-CER,CHIP
1405-001082	V506	VARISTOR	2203-006093	C418	C-CER,CHIP
1405-001082	V507	VARISTOR	2203-006093	C420	C-CER,CHIP
1405-001082	V508	VARISTOR	2203-006093	C421	C-CER,CHIP
1405-001082	V509	VARISTOR	2203-006093	C431	C-CER,CHIP
1405-001082	V510	VARISTOR	2203-006093	C501	C-CER,CHIP
2007-000138	R319	R-CHIP	2203-006137	C208	C-CER,CHIP
2007-000138	R322	R-CHIP	2203-006137	C344	C-CER,CHIP
2007-000139	R102	R-CHIP	2203-006194	C133	C-CER,CHIP
2007-000139	R103	R-CHIP	2203-006194	C134	C-CER,CHIP
2007-000141	R308	R-CHIP	2203-006194	C201	C-CER,CHIP
2007-000144	R100	R-CHIP	2203-006194	C202	C-CER,CHIP
2007-000157	R201	R-CHIP	2203-006194	C205	C-CER,CHIP
2007-000162	R332	R-CHIP	2203-006194	C207	C-CER,CHIP
2007-000163	R324	R-CHIP	2203-006194	C210	C-CER,CHIP
2007-000163	R326	R-CHIP	2203-006194	C337	C-CER,CHIP

SGH-E860V Main Electrical Parts List

SEC Code	Design LOC	Discription	SEC Code	Design LOC	Discription
2007-000170	R318	R-CHIP	2203-006194	C400	C-CER,CHIP
2007-000171	R333	R-CHIP	2203-006194	C401	C-CER,CHIP
2007-000171	R339	R-CHIP	2203-006194	C427	C-CER,CHIP
2007-000171	R350	R-CHIP	2203-006201	C408	C-CER,CHIP
2007-000171	R351	R-CHIP	2203-006208	C123	C-CER,CHIP
2007-000171	R352	R-CHIP	2203-006208	C143	C-CER,CHIP
2007-000171	R353	R-CHIP	2203-006208	C310	C-CER,CHIP
2007-000171	R362	R-CHIP	2203-006208	C338	C-CER,CHIP
2007-000171	R434	R-CHIP	2203-006208	C358	C-CER,CHIP
2007-000171	R501	R-CHIP	2203-006208	C362	C-CER,CHIP
2007-000172	R110	R-CHIP	2203-006208	C433	C-CER,CHIP
2007-000172	R316	R-CHIP	2203-006257	C220	C-CER,CHIP
2007-000172	R317	R-CHIP	2203-006257	C222	C-CER,CHIP
2007-000242	R415	R-CHIP	2203-006257	C357	C-CER,CHIP
2007-001119	R330	R-CHIP	2203-006257	C361	C-CER,CHIP
2007-001119	R349	R-CHIP	2203-006257	C503	C-CER,CHIP
2007-001290	R101	R-CHIP	2203-006344	C131	C-CER,CHIP
2007-001291	R104	R-CHIP	2203-006423	C120	C-CER,CHIP
2007-001301	R420	R-CHIP	2203-006423	C124	C-CER,CHIP
2007-001301	R421	R-CHIP	2203-006423	C126	C-CER,CHIP
2007-001301	R422	R-CHIP	2203-006423	C130	C-CER,CHIP
2007-001301	R423	R-CHIP	2203-006423	C200	C-CER,CHIP
2007-001301	R424	R-CHIP	2203-006423	C203	C-CER,CHIP
2007-001301	R425	R-CHIP	2203-006423	C204	C-CER,CHIP
2007-001301	R429	R-CHIP	2203-006423	C206	C-CER,CHIP
2007-001301	R430	R-CHIP	2203-006423	C212	C-CER,CHIP
2007-001301	R432	R-CHIP	2203-006423	C216	C-CER,CHIP
2007-001306	R431	R-CHIP	2203-006423	C221	C-CER,CHIP
2007-001307	R105	R-CHIP	2203-006423	C302	C-CER,CHIP
2007-001307	R106	R-CHIP	2203-006423	C309	C-CER,CHIP
2007-001325	R406	R-CHIP	2203-006423	C311	C-CER,CHIP
2007-003025	R312	R-CHIP	2203-006423	C316	C-CER,CHIP
2007-003025	R313	R-CHIP	2203-006423	C347	C-CER,CHIP
2007-007009	R208	R-CHIP	2203-006423	C348	C-CER,CHIP
2007-007009	R209	R-CHIP	2203-006423	C370	C-CER,CHIP
2007-007014	R403	R-CHIP	2203-006423	C402	C-CER,CHIP
2007-007142	R314	R-CHIP	2203-006423	C403	C-CER,CHIP

SEC Code	Design LOC	Discription	SEC Code	Design LOC	Discription
2007-007142	R323	R-CHIP	2203-006423	C405	C-CER,CHIP
2007-007142	R325	R-CHIP	2203-006423	C412	C-CER,CHIP
2007-007142	R334	R-CHIP	2203-006423	C414	C-CER,CHIP
2007-007142	R336	R-CHIP	2203-006423	C424	C-CER,CHIP
2007-007308	R409	R-CHIP	2203-006423	C436	C-CER,CHIP
2007-007314	R410	R-CHIP	2203-006423	C438	C-CER,CHIP
2007-007489	R401	R-CHIP	2203-006423	C439	C-CER,CHIP
2007-007528	R328	R-CHIP	2203-006423	C512	C-CER,CHIP
2007-007528	R329	R-CHIP	2203-006423	C513	C-CER,CHIP
2007-007528	R331	R-CHIP	2203-006423	C524	C-CER,CHIP
2007-007528	R338	R-CHIP	2203-006474	C432	C-CER,CHIP
2007-007590	R335	R-CHIP	2203-006626	C342	C-CER,CHIP
2007-007590	R337	R-CHIP	2203-006626	C343	C-CER,CHIP
2007-007590	R400	R-CHIP	2203-006626	C363	C-CER,CHIP
2007-008045	R112	R-CHIP	2404-001225	C219	C-TA,CHIP
2007-008045	R310	R-CHIP	2404-001225	C314	C-TA,CHIP
2007-008045	R408	R-CHIP	2404-001225	C315	C-TA,CHIP
2007-008055	R200	R-CHIP	2404-001225	C437	C-TA,CHIP
2007-008055	R202	R-CHIP	2404-001225	C441	C-TA,CHIP
2007-008055	R211	R-CHIP	2404-001226	C323	C-TA,CHIP
2007-008055	R212	R-CHIP	2404-001274	C103	C-TA,CHIP
2007-008055	R302	R-CHIP	2404-001274	C510	C-TA,CHIP
2007-008055	R433	R-CHIP	2404-001339	C411	C-TA,CHIP
2007-008055	R516	R-CHIP	2404-001352	C341	C-TA,CHIP
2007-008117	R515	R-CHIP	2404-001352	C360	C-TA,CHIP
2007-008419	R402	R-CHIP	2404-001353	C312	C-TA,CHIP
2007-008419	R500	R-CHIP	2404-001353	C313	C-TA,CHIP
2007-008419	R502	R-CHIP	2404-001394	C218	C-TA,CHIP
2007-008419	R503	R-CHIP	2404-001394	C307	C-TA,CHIP
2007-008419	R504	R-CHIP	2404-001394	C522	C-TA,CHIP
2007-008419	R505	R-CHIP	2703-001512	L101	INDUCTOR-SMD
2007-008419	R506	R-CHIP	2703-001990	L100	INDUCTOR-SMD
2007-008419	R507	R-CHIP	2703-002313	L108	INDUCTOR-SMD
2007-008419	R508	R-CHIP	2703-002313	L301	INDUCTOR-SMD
2007-008419	R510	R-CHIP	2703-002313	L302	INDUCTOR-SMD
2007-008419	R517	R-CHIP	2703-002547	L104	INDUCTOR-SMD
2007-008483	R107	R-CHIP	2703-002665	L105	INDUCTOR-SMD

SGH-E860V Main Electrical Parts List

SEC Code	Design LOC	Discription	SEC Code	Design LOC	Discription
2007-008483	R109	R-CHIP	2703-002734	L401	INDUCTOR-SMD
2007-008483	R309	R-CHIP	2703-002775	L400	INDUCTOR-SMD
2007-008483	R327	R-CHIP	2801-004340	OSC300	CRYSTAL-SMD
2007-008483	R342	R-CHIP	2801-004373	OSC200	CRYSTAL-SMD
2007-008483	R412	R-CHIP	2809-001300	OSC100	OSCILLATOR-VCTCXO
2007-008483	R413	R-CHIP	2901-001296	F500	FILTER-EMI SMD
2007-008483	R414	R-CHIP	2901-001296	F501	FILTER-EMI SMD
2007-008516	R111	R-CHIP	2901-001296	F502	FILTER-EMI SMD
2007-008516	R210	R-CHIP	2901-001296	F507	FILTER-EMI SMD
2007-008516	R407	R-CHIP	2901-001296	F508	FILTER-EMI SMD
2007-008587	R113	R-CHIP	2911-000004	F100	DUPLEXER-FEM
2007-008588	R114	R-CHIP	3301-001342	F200	BEAD-SMD
2007-008588	R303	R-CHIP	3301-001342	F300	BEAD-SMD
2007-008588	R304	R-CHIP	3301-001342	L303	BEAD-SMD
2007-009084	R306	R-CHIP	3705-001358	CN100	CONNECTOR-COAXIAL
2007-009084	R311	R-CHIP	3708-002063	CN500	CONNECTOR-FPC/FFC/PIC
2007-009124	R416	R-CHIP	3709-001355	CN400	CONNECTOR-CARD EDGE
2007-009124	R418	R-CHIP	3710-001611	CN501	CONNECTOR-INTERFACE
2203-000233	C100	C-CER,CHIP	3711-005829	CN503	CONNECTOR-BATTERY
2203-000233	C106	C-CER,CHIP	3722-002181	CN301	JACK-EAR PHONE
2203-000233	C110	C-CER,CHIP	4202-001053	CN101	ANTENNA-CHIP
2203-000233	C135	C-CER,CHIP	4302-001158	M400	BATTERY-LI(2ND)
2203-000233	C137	C-CER,CHIP	4709-001372	U102	BLUETOOTH MODULE
2203-000233	C138	C-CER,CHIP	GH09-00038A	U200	IC MICOM
2203-000233	C139	C-CER,CHIP	GH41-00854A		PCB MAIN-SGHE860V
2203-000233	C422	C-CER,CHIP	GH96-01915A		ELA UNIT-SGHE860V
2203-000254	C101	C-CER,CHIP	GH30-00180A		MICROPHONE-ASSY
2203-000254	C104	C-CER,CHIP	GH59-01979A		UNIT-METAL DOME(MAIN)
2203-000254	C105	C-CER,CHIP	GH59-01981A		UNIT-SIDE KEY
2203-000254	C141	C-CER,CHIP	GH59-01982A		UNIT-CAMERA KEY
2203-000254	C428	C-CER,CHIP	GH68-02026A		LABEL(P)-WATER SOAK
2203-000311	C102	C-CER,CHIP	GH74-08516A		MPR-LOWER TAPE -A
2203-000330	C327	C-CER,CHIP	GH74-12604A		MPR-MAIN FPCB TAPE
2203-000330	C328	C-CER,CHIP	GH74-12608A		MPR-KEYPAD EMI TAPE
2203-000359	C335	C-CER,CHIP	GH74-12612A		MPR-MAIN FPCB SHIELD EMI
2203-000359	C336	C-CER,CHIP	GH74-12813A		MPR-MAIN GROUND EMI TAPE
2203-000386	C214	C-CER,CHIP	GH74-16894A		MPR-TAPE LED INSULATION
2203-000386	C215	C-CER,CHIP			

4-2. Sub

SEC Code	Design LOC	Discription	SEC Code	Design LOC	Discription
0406-001210	ZD101	DIODE-TVS	2203-000812	C149	C-CER,CHIP
0406-001210	ZD102	DIODE-TVS	2203-001124	C157	C-CER,CHIP
0406-001210	ZD103	DIODE-TVS	2203-001124	C158	C-CER,CHIP
0407-000115	D103	DIODE-ARRAY	2203-001432	C102	C-CER,CHIP
0601-001819	LED100	LED	2203-001432	C103	C-CER,CHIP
0601-001819	LED101	LED	2203-005719	C126	C-CER,CHIP
0601-001819	LED102	LED	2203-005719	C127	C-CER,CHIP
0601-001819	LED103	LED	2203-005806	C107	C-CER,CHIP
0601-001819	LED104	LED	2203-005806	C133	C-CER,CHIP
0601-001819	LED105	LED	2203-005806	C138	C-CER,CHIP
1001-001231	U109	IC-ANALOG SWITCH	2203-006090	C141	C-CER,CHIP
1001-001261	U110	IC-ANALOG SWITCH	2203-006093	C104	C-CER,CHIP
1001-001306	U108	IC-ANALOG MULTIPLEX	2203-006093	C105	C-CER,CHIP
1201-002007	U107	IC-AUDIO AMP	2203-006093	C110	C-CER,CHIP
1201-002233	U104	IC-AUDIO AMP	2203-006093	C112	C-CER,CHIP
1203-002850	U100	IC-DC/DC CONVERTER	2203-006093	C113	C-CER,CHIP
1203-002860	U103	IC-MULTI REG.	2203-006093	C114	C-CER,CHIP
1203-003046	U102	IC-BATTERY	2203-006093	C118	C-CER,CHIP
1203-003275	U101	IC-MULTI REG.	2203-006093	C121	C-CER,CHIP
1203-003735	U105	IC-POSI.FIXED REG			
2203-006093				C154	C-CER,CHIP
1405-001082	V104	VARISTOR	2203-006093	C160	C-CER,CHIP
1405-001082	V105	VARISTOR	2203-006093	C164	C-CER,CHIP
1405-001082	V106	VARISTOR	2203-006141	C120	C-CER,CHIP
1405-001082	V107	VARISTOR	2203-006183	C123	C-CER,CHIP
1405-001082	V108	VARISTOR	2203-006190	C109	C-CER,CHIP
1405-001082	V109	VARISTOR	2203-006194	C134	C-CER,CHIP
1405-001082	V110	VARISTOR	2203-006194	C147	C-CER,CHIP
1405-001082	V111	VARISTOR	2203-006194	C165	C-CER,CHIP
1405-001082	V112	VARISTOR	2203-006208	C106	C-CER,CHIP
1405-001093	V101	VARISTOR	2203-006208	C143	C-CER,CHIP
1405-001093	V102	VARISTOR	2203-006423	C111	C-CER,CHIP
2007-000143	R102	R-CHIP	2203-006423	C115	C-CER,CHIP
2007-000161	R103	R-CHIP	2203-006423	C117	C-CER,CHIP
2007-000161	R104	R-CHIP	2203-006423	C119	C-CER,CHIP
2007-000174	R134	R-CHIP	2203-006423	C122	C-CER,CHIP

SGH-E860V Main Electrical Parts List

SEC Code	Design LOC	Discription	SEC Code	Design LOC	Discription
2007-001290	R109	R-CHIP	2203-006423	C125	C-CER,CHIP
2007-001290	R110	R-CHIP	2203-006423	C140	C-CER,CHIP
2007-001298	R112	R-CHIP	2203-006423	C145	C-CER,CHIP
2007-001298	R113	R-CHIP	2203-006423	C162	C-CER,CHIP
2007-001298	R114	R-CHIP	2203-006474	C136	C-CER,CHIP
2007-001301	R115	R-CHIP	2203-006647	C135	C-CER,CHIP
2007-001301	R116	R-CHIP	2203-006647	C163	C-CER,CHIP
2007-001301	R117	R-CHIP	2404-001381	C108	C-TA,CHIP
2007-001301	R118	R-CHIP	2404-001381	C116	C-TA,CHIP
2007-001301	R119	R-CHIP	2404-001381	C128	C-TA,CHIP
2007-001301	R120	R-CHIP	2404-001381	C137	C-TA,CHIP
2007-003112	R127	R-CHIP	2404-001381	C142	C-TA,CHIP
2007-007134	R124	R-CHIP	2404-001381	C159	C-TA,CHIP
2007-007134	R126	R-CHIP	2703-002767	L103	INDUCTOR-SMD
2007-008052	R107	R-CHIP	2901-001296	L105	FILTER-EMI SMD
2007-008052	R135	R-CHIP	2901-001296	L106	FILTER-EMI SMD
2007-008055	R130	R-CHIP	3301-001158	L101	BEAD-SMD
2007-008210	R108	R-CHIP	3301-001158	L102	BEAD-SMD
2007-008483	R111	R-CHIP	3301-001342	L100	BEAD-SMD
2007-008483	R125	R-CHIP	3708-001890	CN102	CONNECTOR-FPC/FFC/PIC
2007-008483	R129	R-CHIP	3708-002003	CN103	CONNECTOR-FPC/FFC/PIC
2007-008483	R132	R-CHIP	3708-002063	CN104	CONNECTOR-FPC/FFC/PIC
2007-008483	R133	R-CHIP	3708-002106	CN105	CONNECTOR-FPC/FFC/PIC
2007-008516	R100	R-CHIP	GH41-00855A		PCB SUB-SGHE860V
2007-008516	R101	R-CHIP	GH59-01980A		UNIT-METAL DOME(SUB)
2007-008588	R131	R-CHIP	GH74-12599A		MPR-CAMERA INSULATION
2203-000254	C152	C-CER,CHIP	GH74-12604A		MPR-MAIN FPCB TAPE
2203-000254	C153	C-CER,CHIP	GH74-12606A		MPR-LCD DOME EMI TAPE R
2203-000812	C148	C-CER,CHIP	GH74-16891A		MPR-LCD DOME EMI TAPE R

5. SGH-E860V PCB Diagrams

5-1. Main

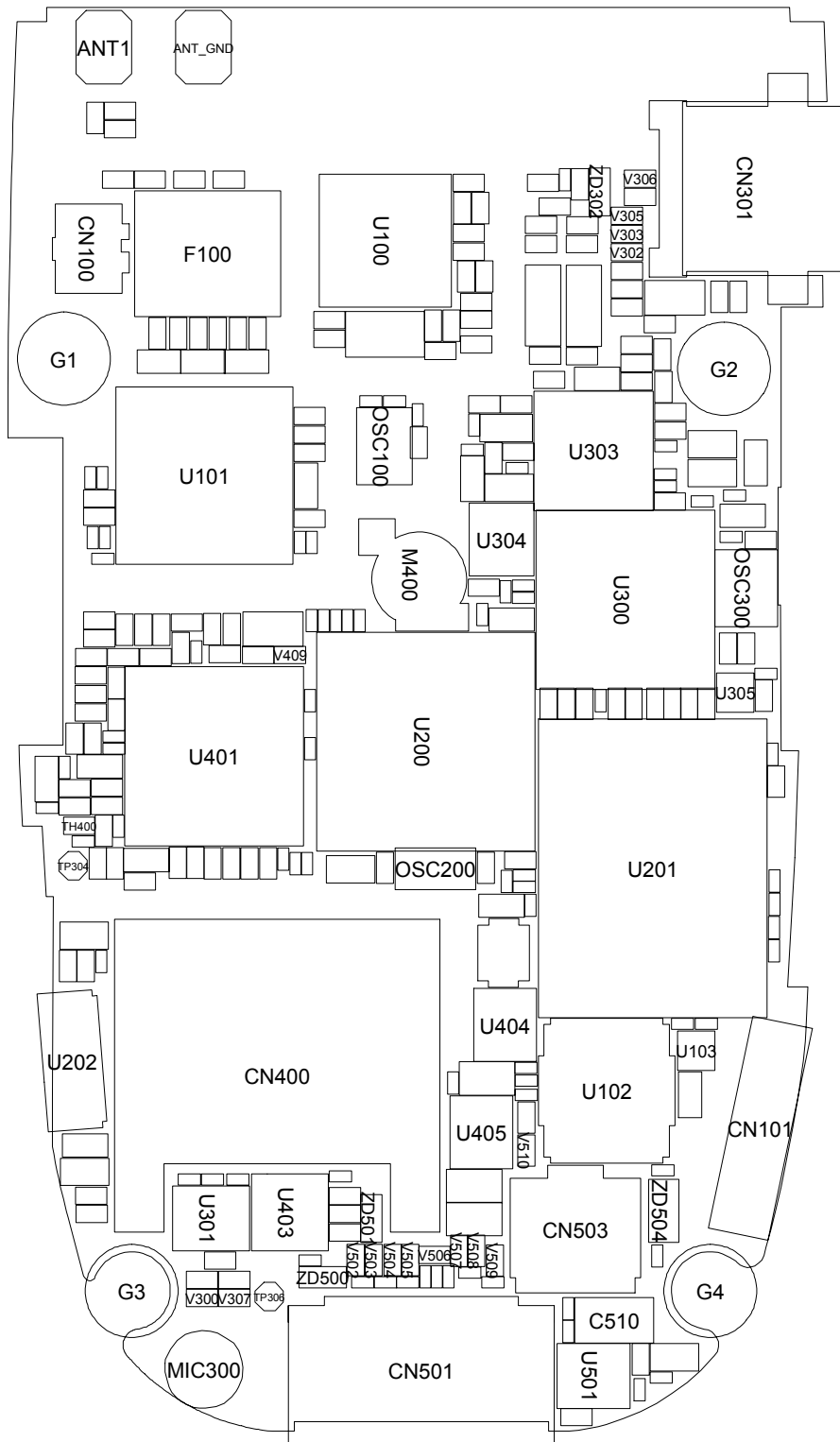

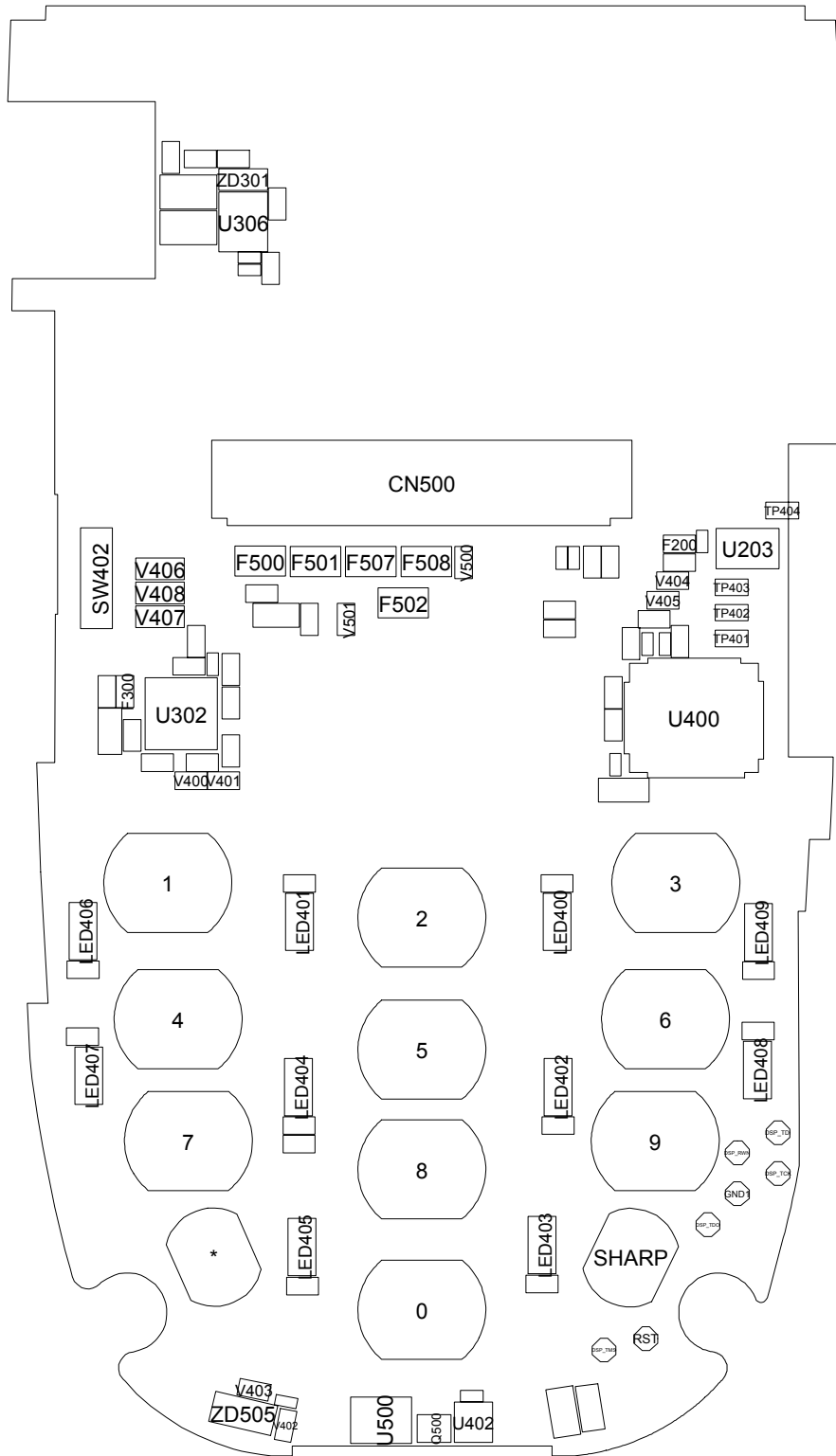

5-2. LCD

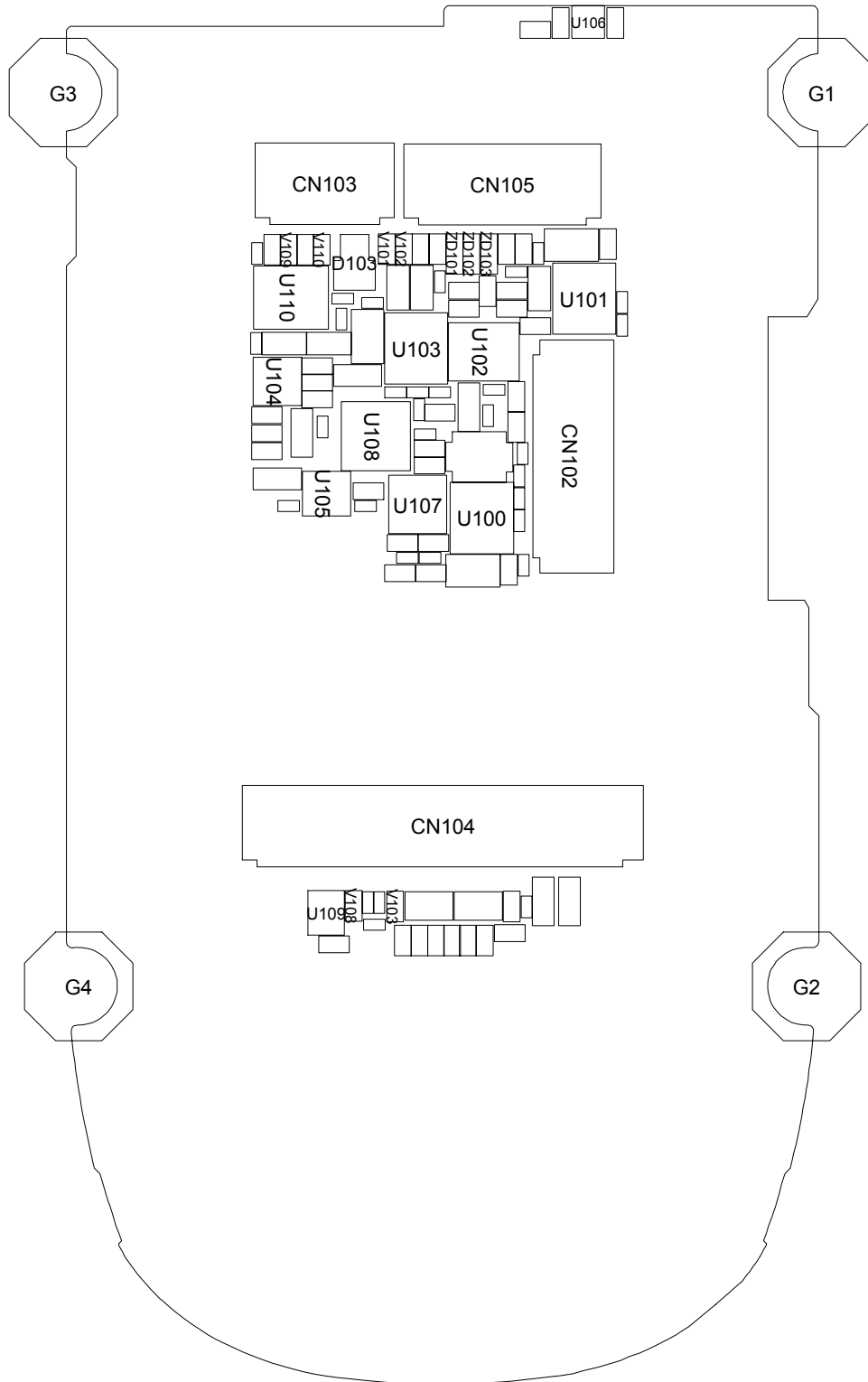

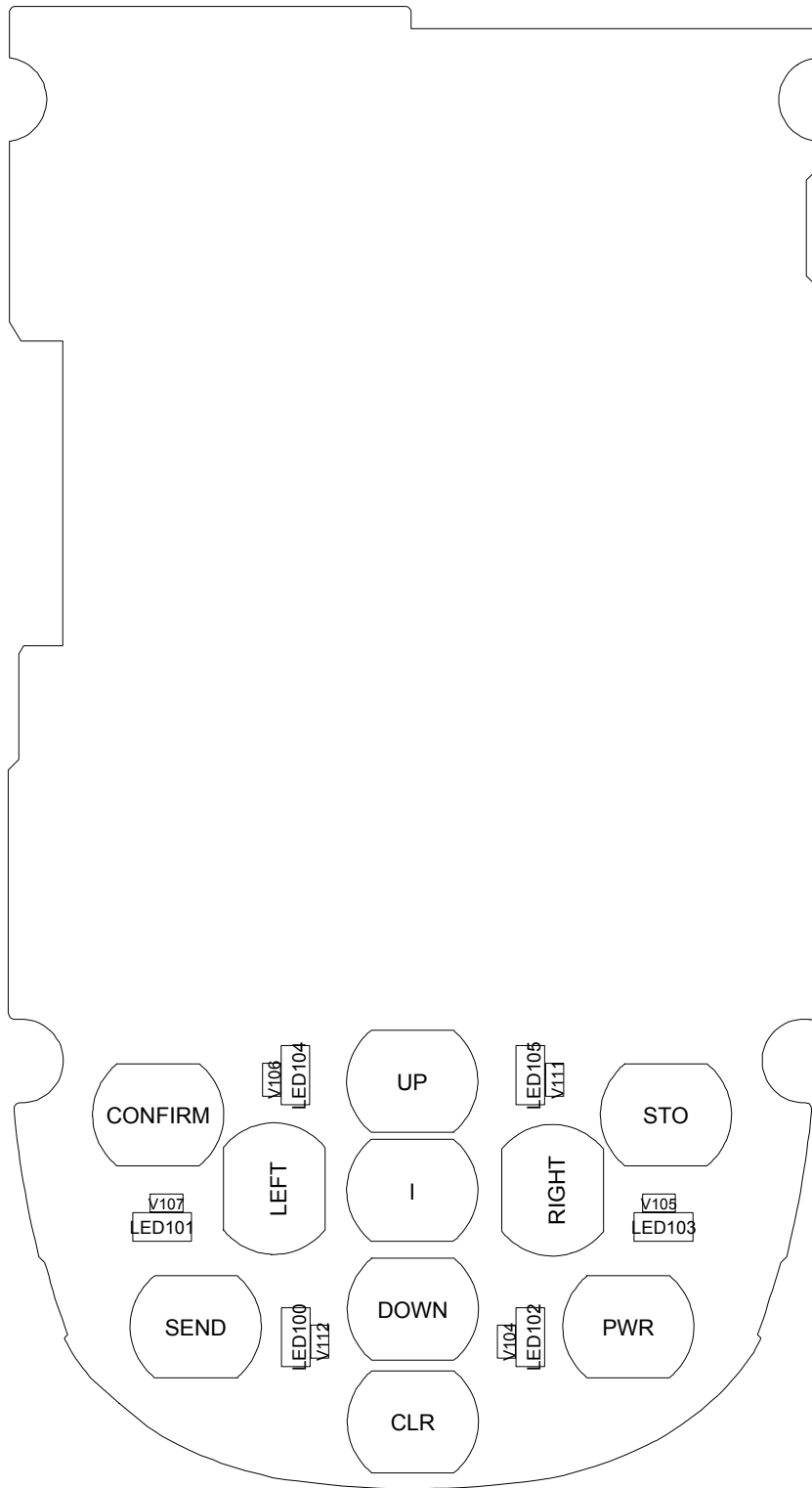

6. SGH-E860V Block Diagrams

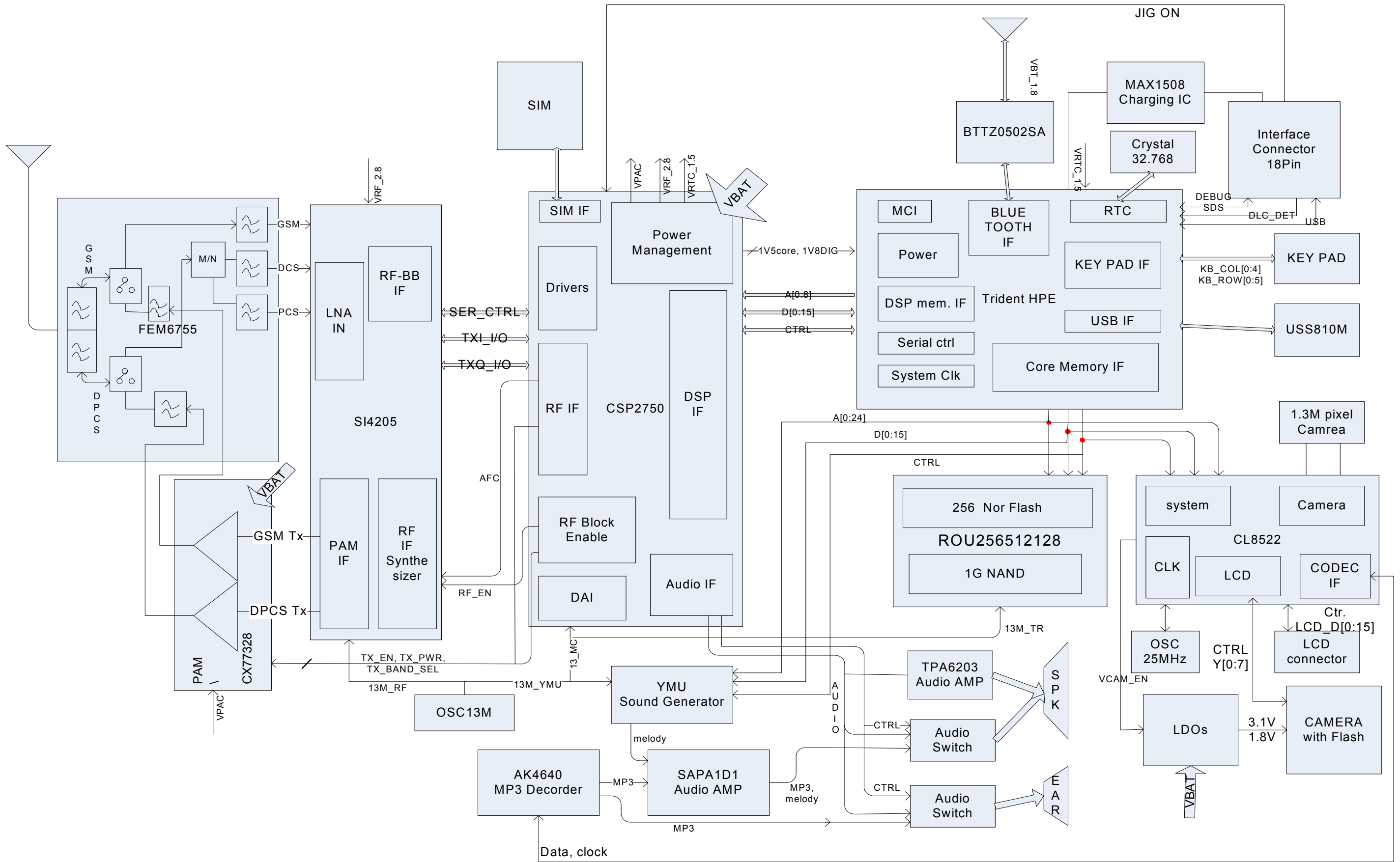

**SAMSUNG
ELECTRONICS**

