

**SAMSUNG**

# GSM TELEPHONE

## SGH-E530

# ***SERVICE*** *Manual*

### GSM TELEPHONE



### CONTENTS

1. Specification
2. Flow Chart of Troubleshooting
3. Exploded Views and Parts List
4. Electrical Parts List
5. PCB Diagrams
6. Block Diagrams

---

# 1. SGH-E530 Specification

---

## 1-1. GSM General Specification

	<b>GSM900 Phase 1</b>	<b>EGSM 900 Phase 2</b>	<b>DCS1800 Phase 1</b>
Freq. Band[MHz] Uplink/Downlink	890~915 935~960	880~915 925~960	1710~1785 1805~1880
ARFCN range	1~124	0~124 & 975~1023	512~885
Tx/Rx spacing	45MHz	45MHz	95MHz
Mod. Bit rate/ Bit Period	270.833kbps 3.692us	270.833kbps 3.692us	270.833kbps 3.692us
Time Slot Period/Frame Period	576.9us 4.615ms	576.9us 4.615ms	576.9us 4.615ms
Modulation	0.3GMSK	0.3GMSK	0.3GMSK
MS Power	33dBm~13dBm	33dBm~5dBm	30dBm~0dBm
Power Class	5pcl ~ 15pcl	5pcl ~ 19pcl	0pcl ~ 15pcl
Sensitivity	-102dBm	-102dBm	-100dBm
TDMA Mux	8	8	8
Cell Radius	35Km	35Km	2Km

## 1-2. GSM TX power class

<b>TX Power control level</b>	<b>GSM900</b>	<b>TX Power control level</b>	<b>DCS1800</b>
5	33±2 dBm	0	30±3 dBm
6	31±2 dBm	1	28±3 dBm
7	29±2 dBm	2	26±3 dBm
8	27±2 dBm	3	24±3 dBm
9	25±2 dBm	4	22±3 dBm
10	23±2 dBm	5	20±3 dBm
11	21±2 dBm	6	18±3 dBm
12	19±2 dBm	7	16±3 dBm
13	17±2 dBm	8	14±3 dBm
14	15±2 dBm	9	12±4 dBm
15	13±2 dBm	10	10±4 dBm
16	11±3 dBm	11	8±4 dBm
17	9± 3dBm	12	6±4 dBm
18	7±3 dBm	13	4±4 dBm
19	5±3 dBm	14	2±5 dBm
		15	0±5 dBm

## 2. SGH-E530 Flow Chart of Troubleshooting

### 2-1.Baseband

#### 2-1-1. Power ON

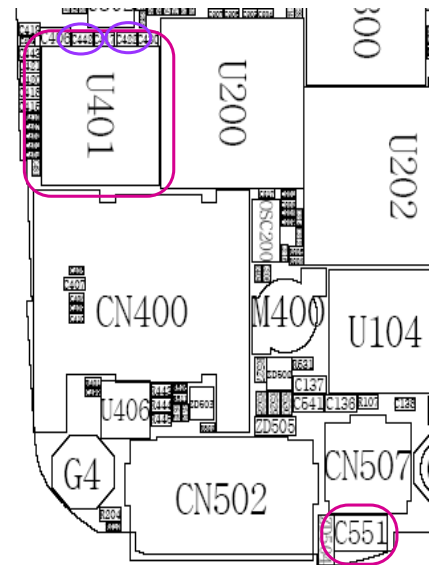
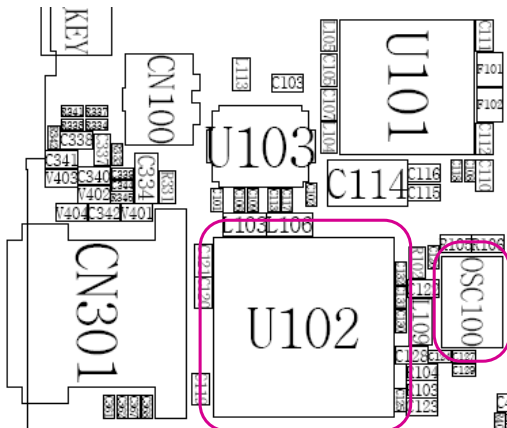
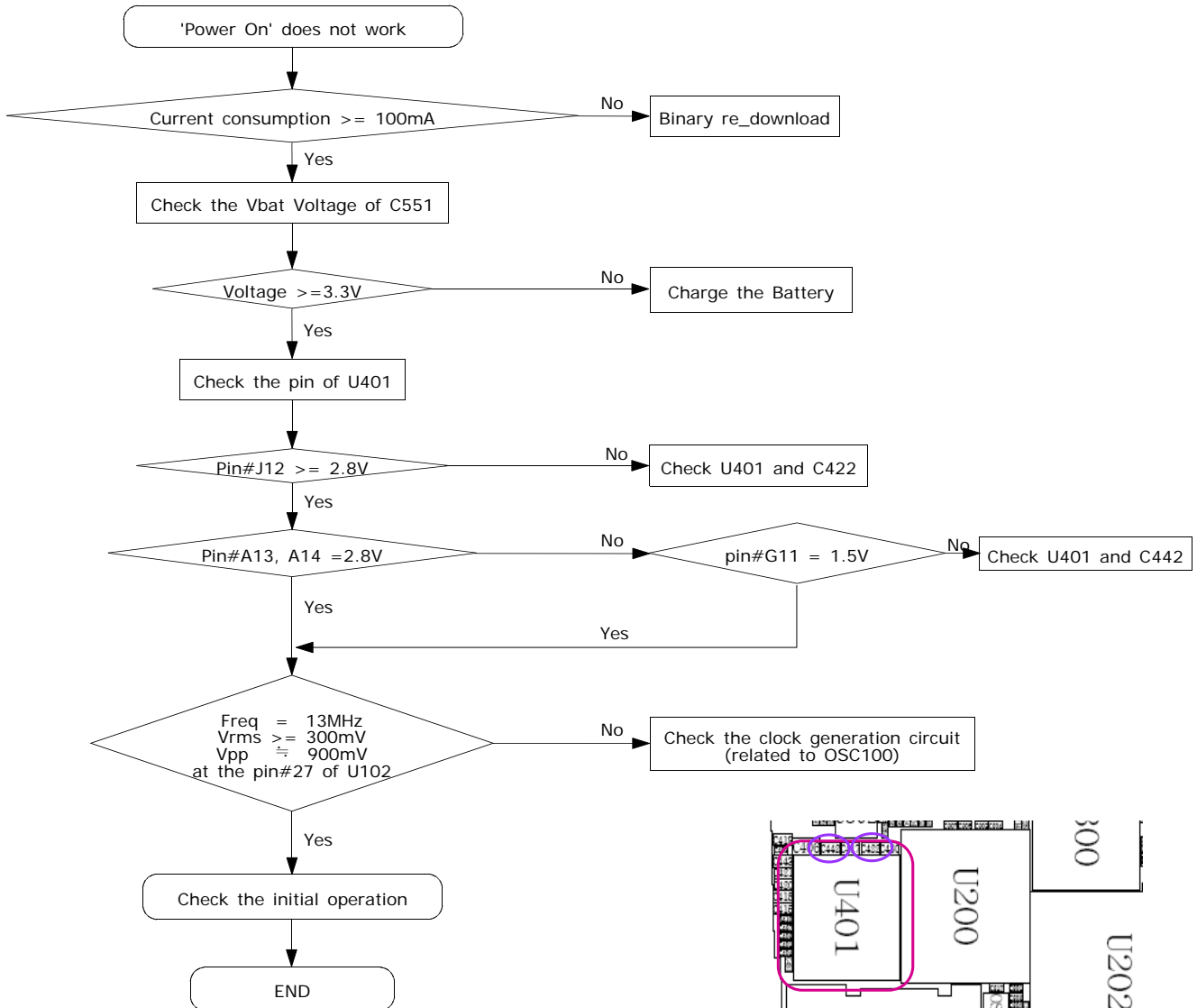

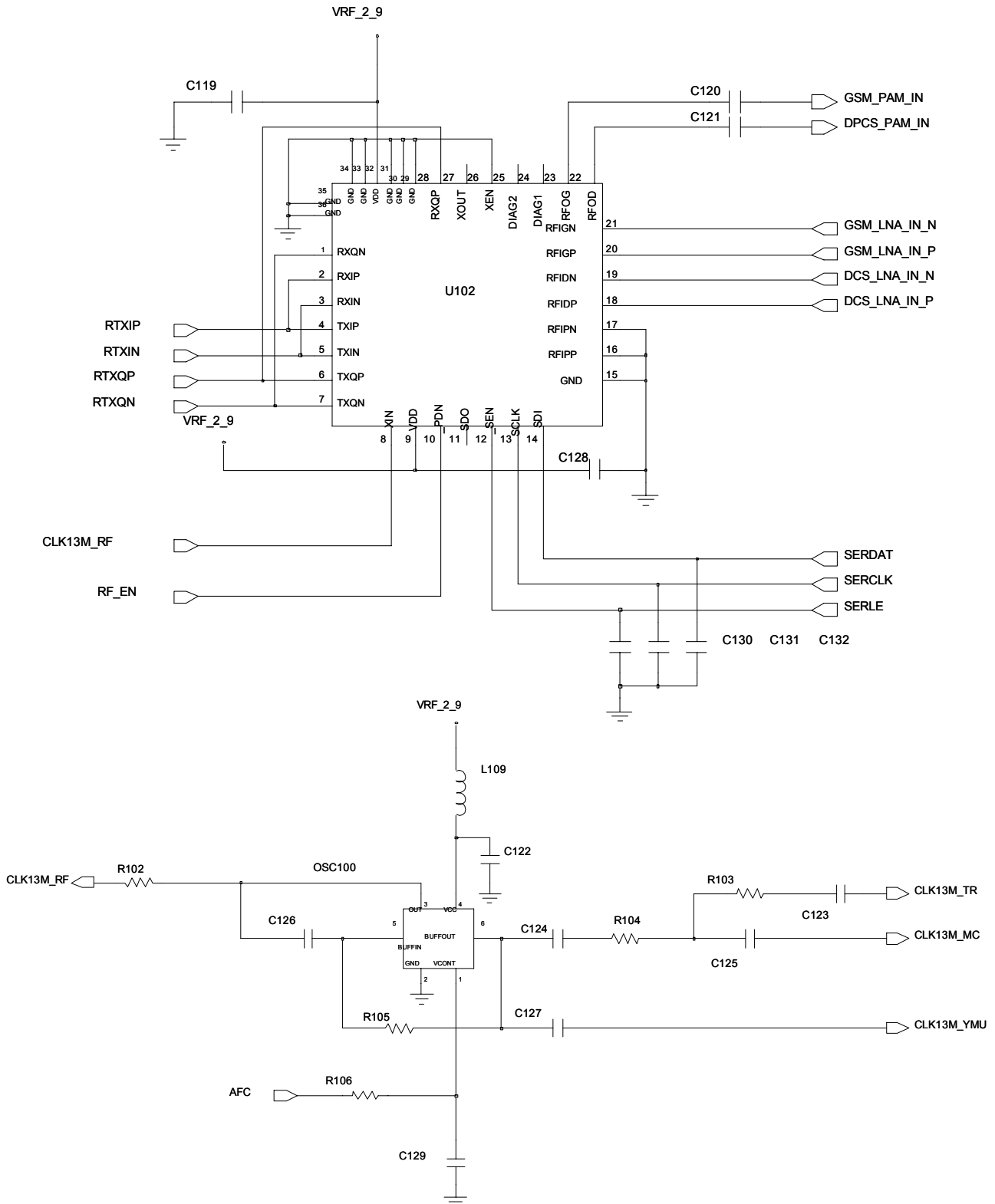

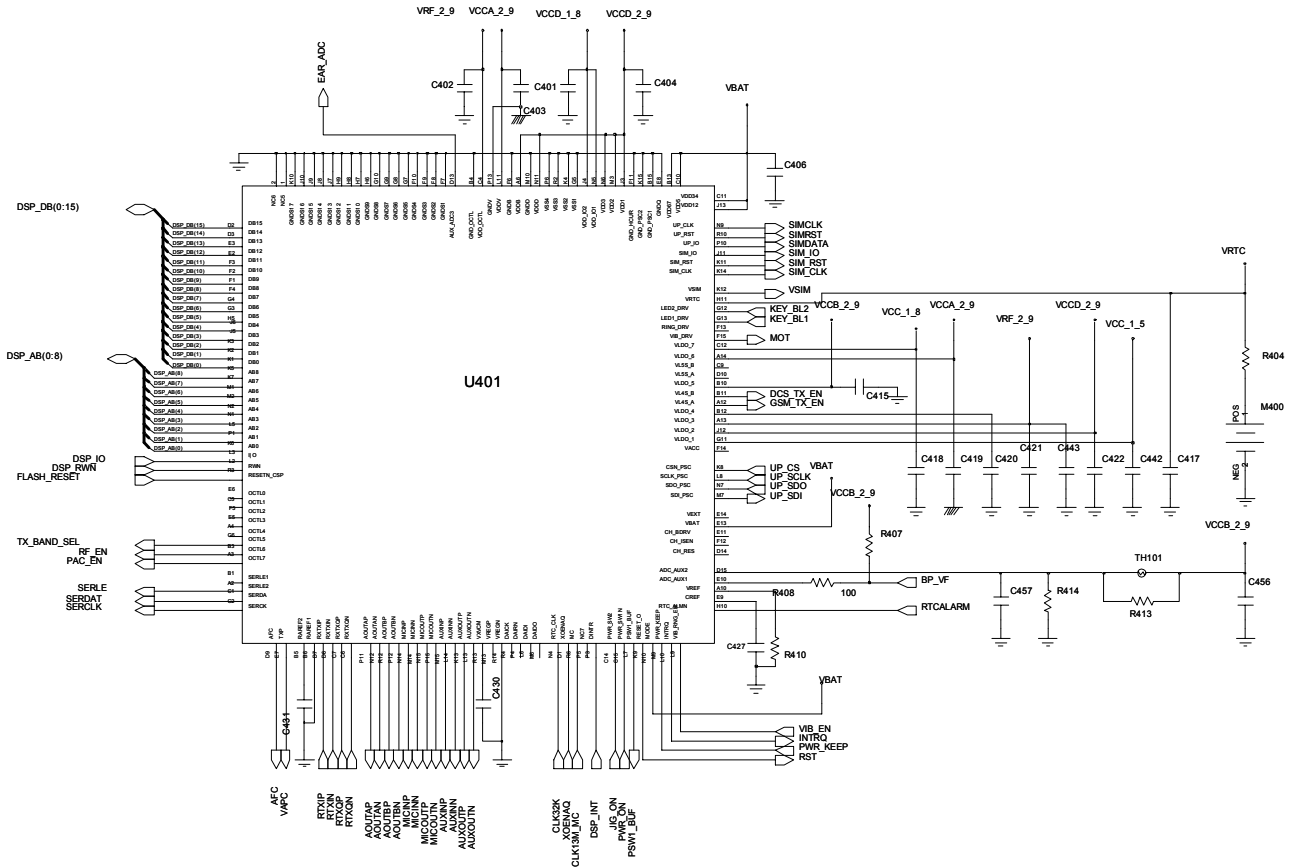

### 2-1-2. Initial

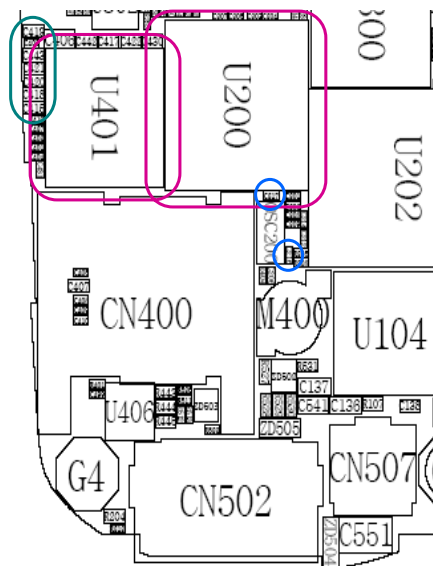
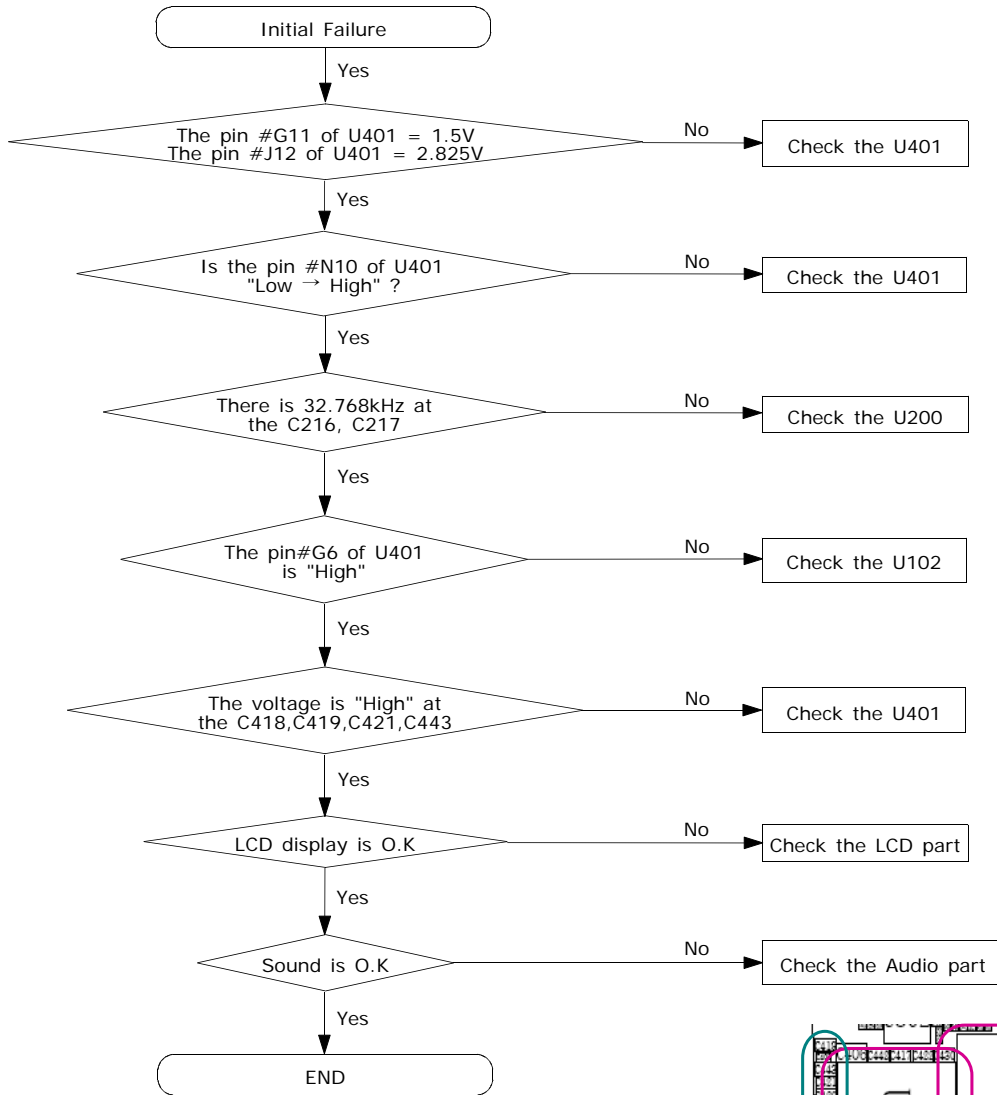

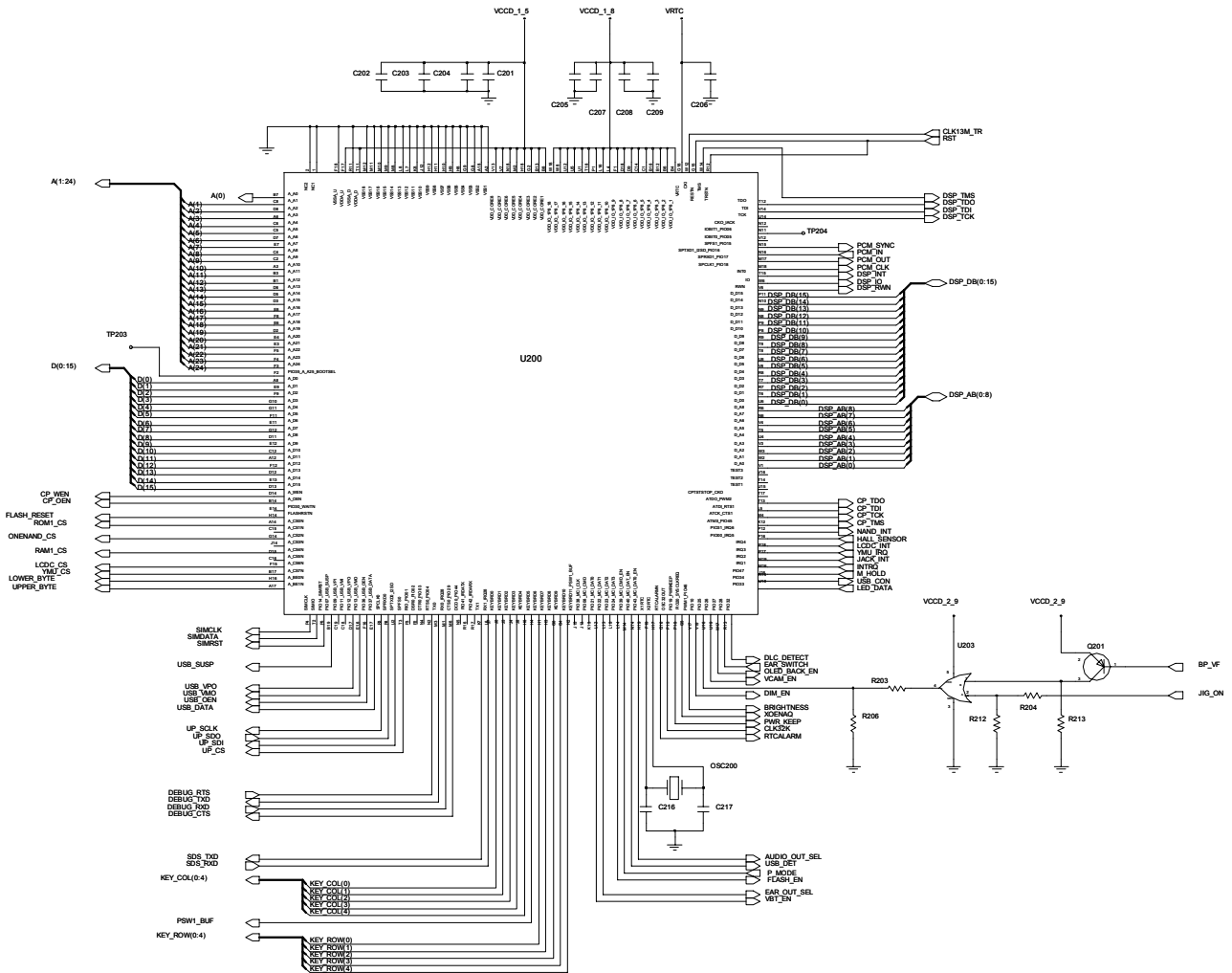



### 2-1-3. Sim Part

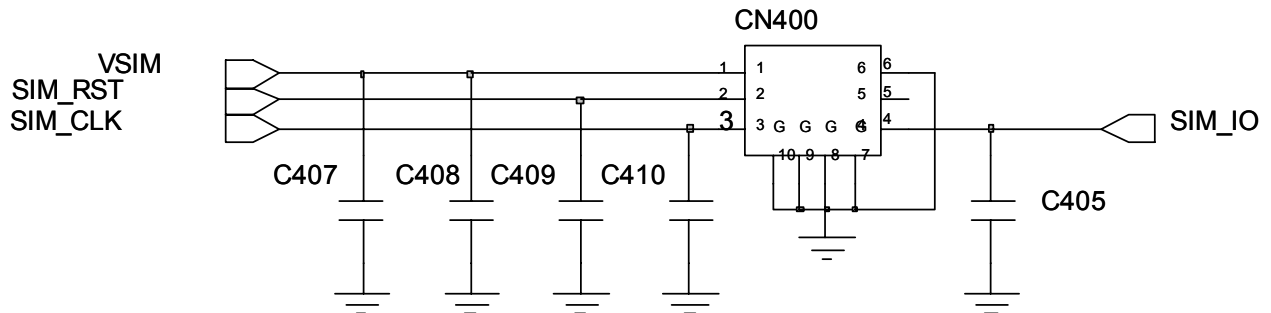
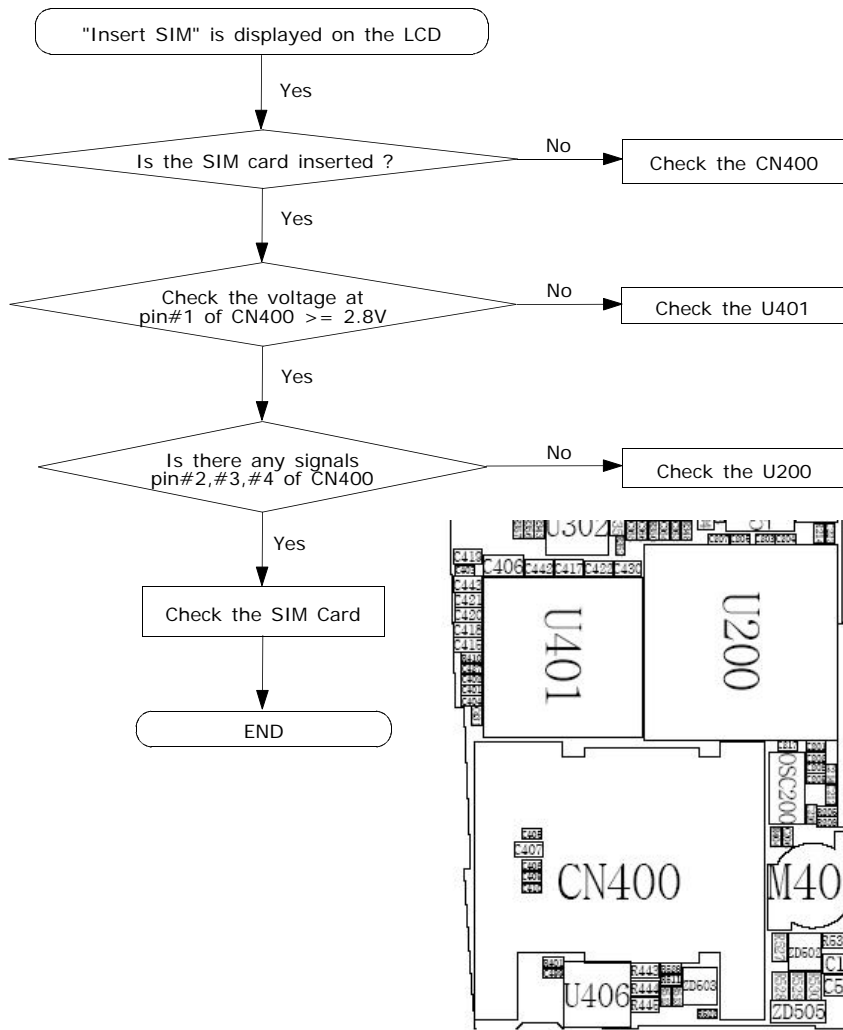

### 2-1-4. Microphone Part

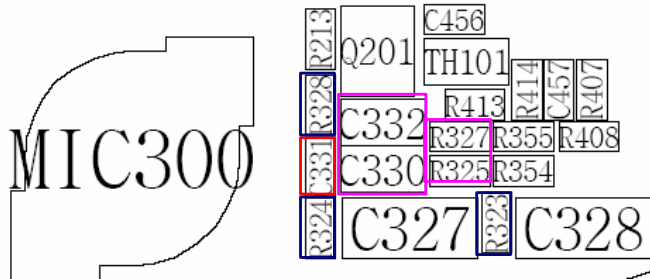
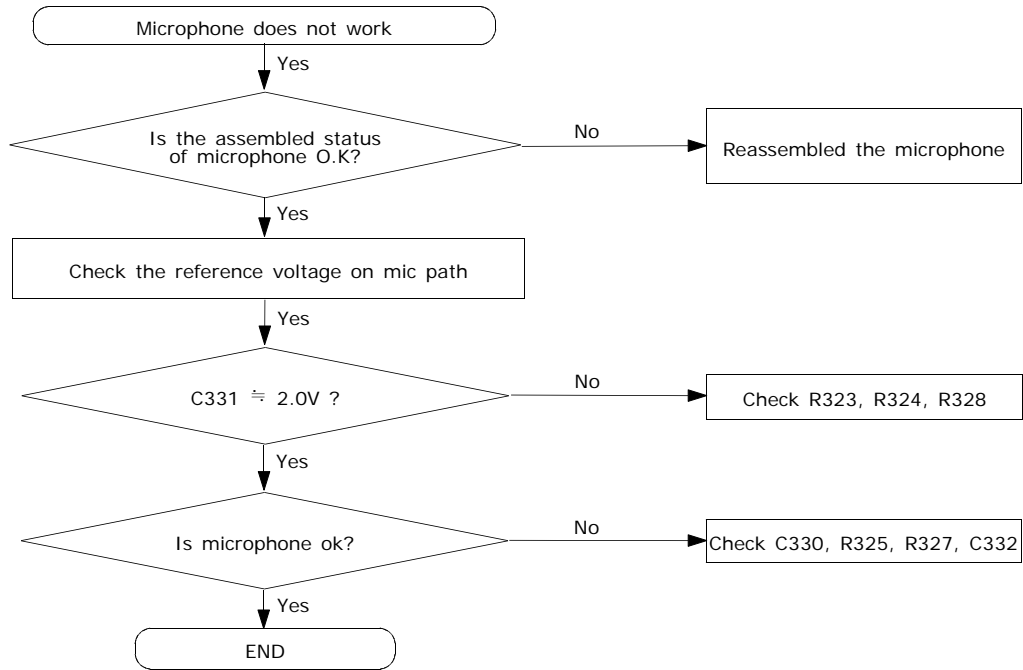

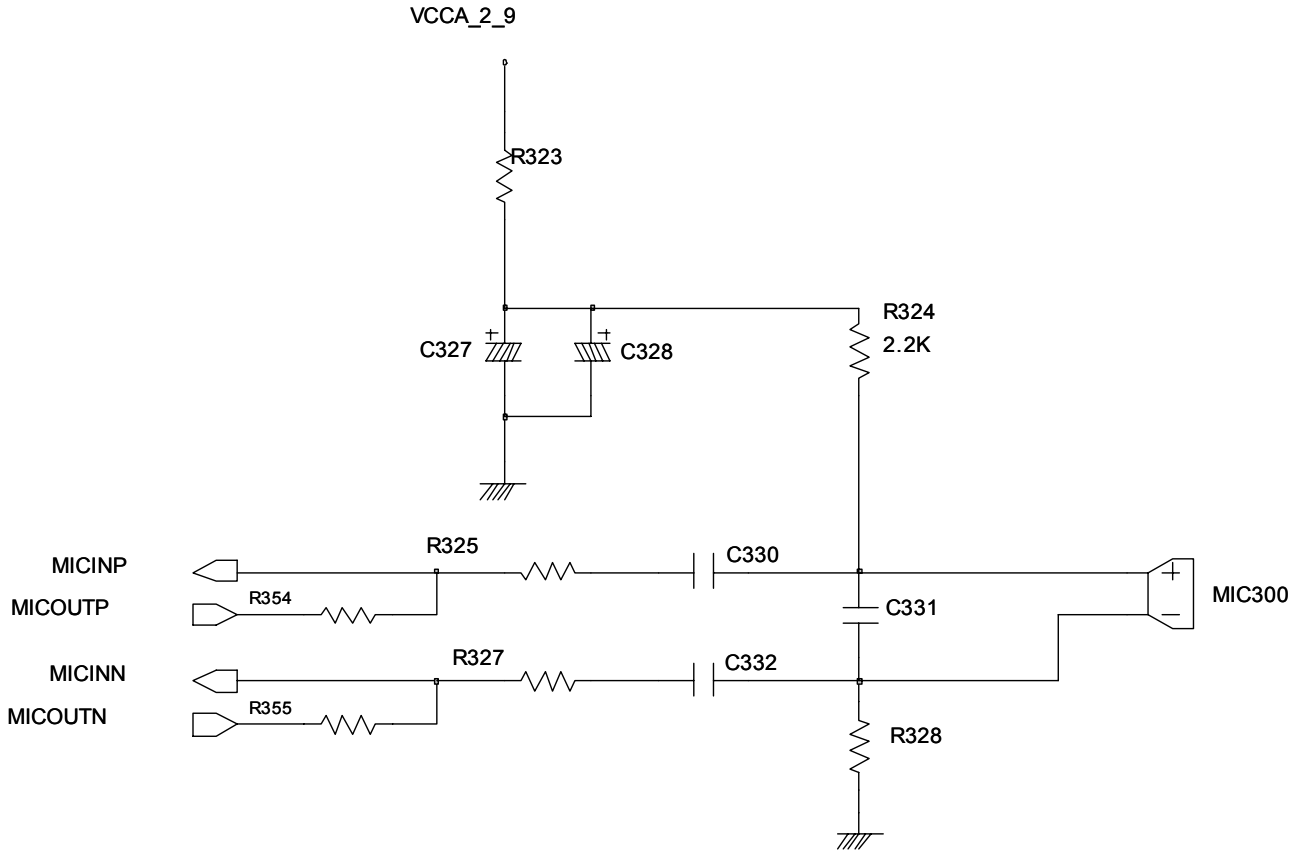

### 2-1-5. Speaker Part

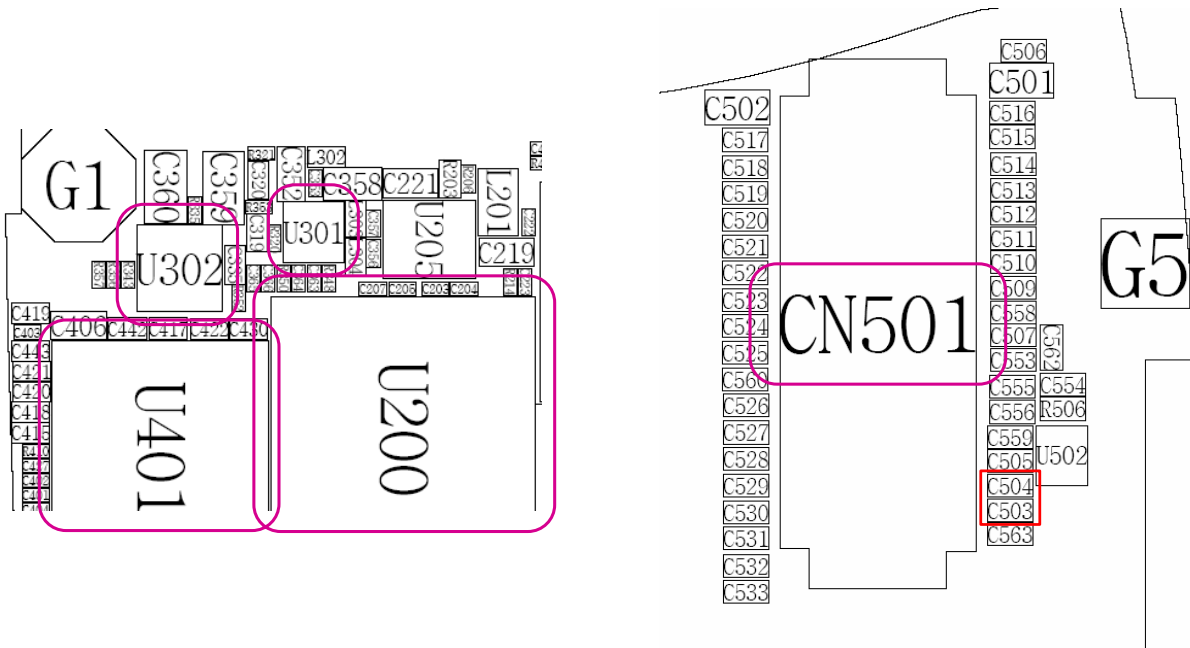
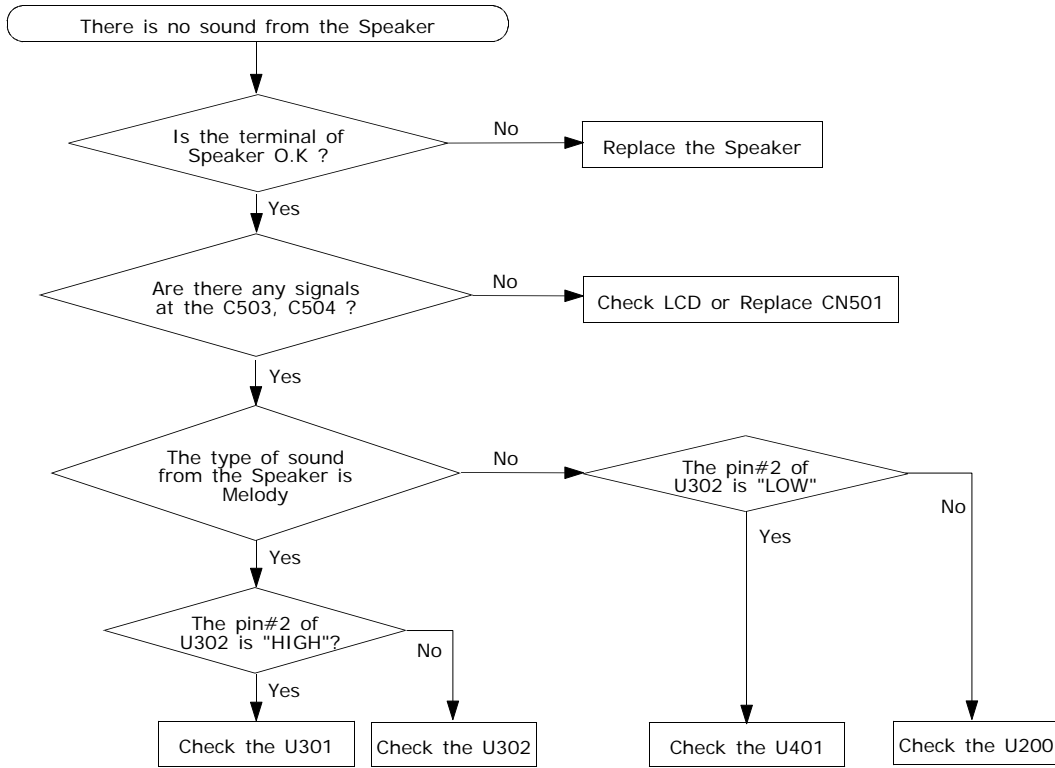

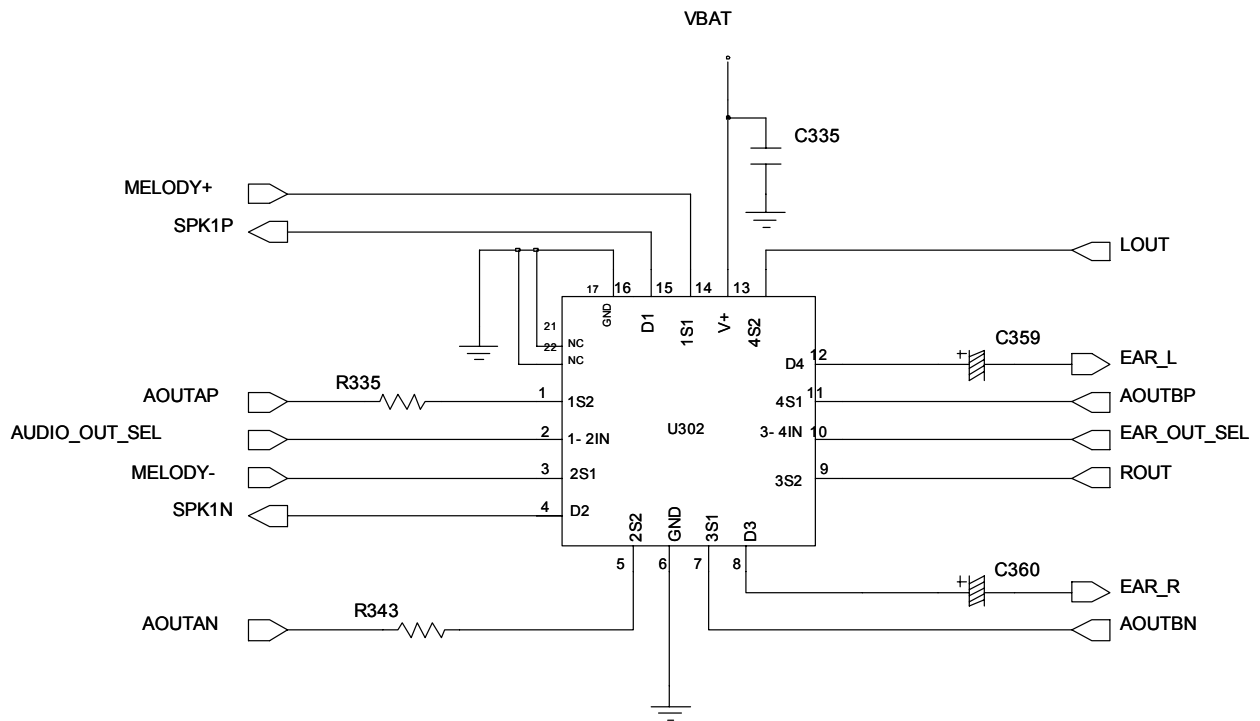
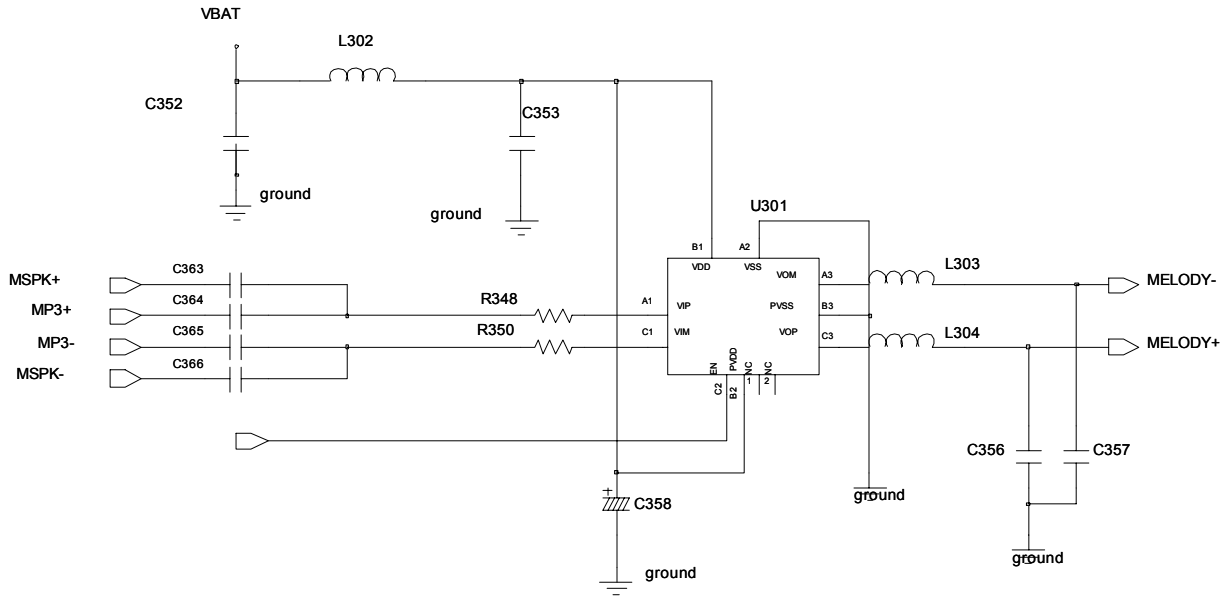

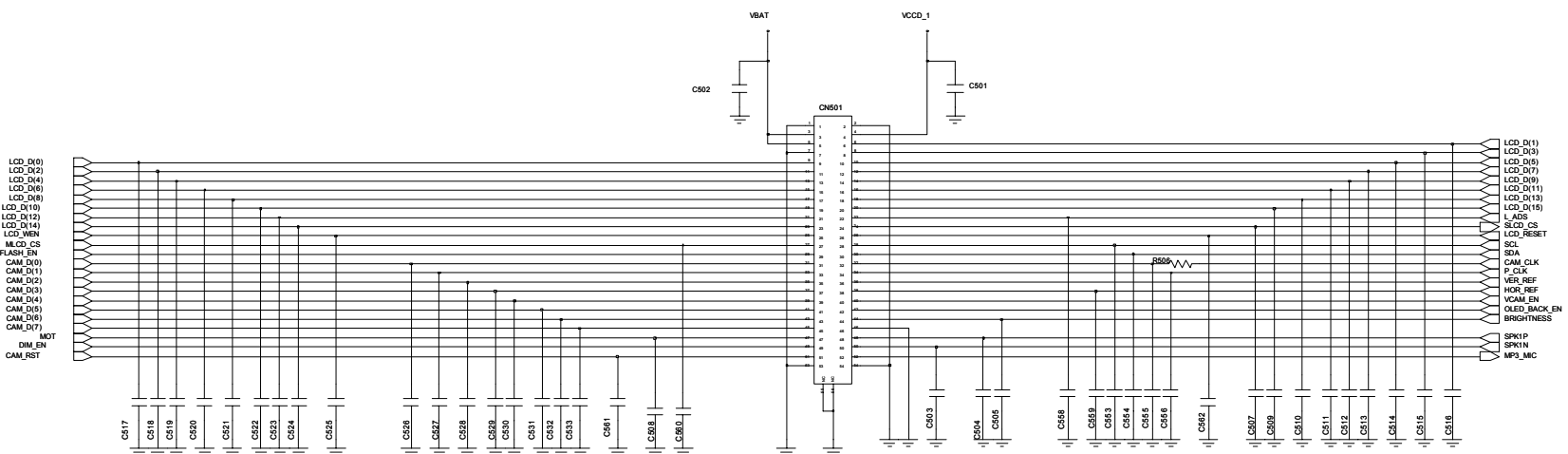

### 2-1-6. Camera Part

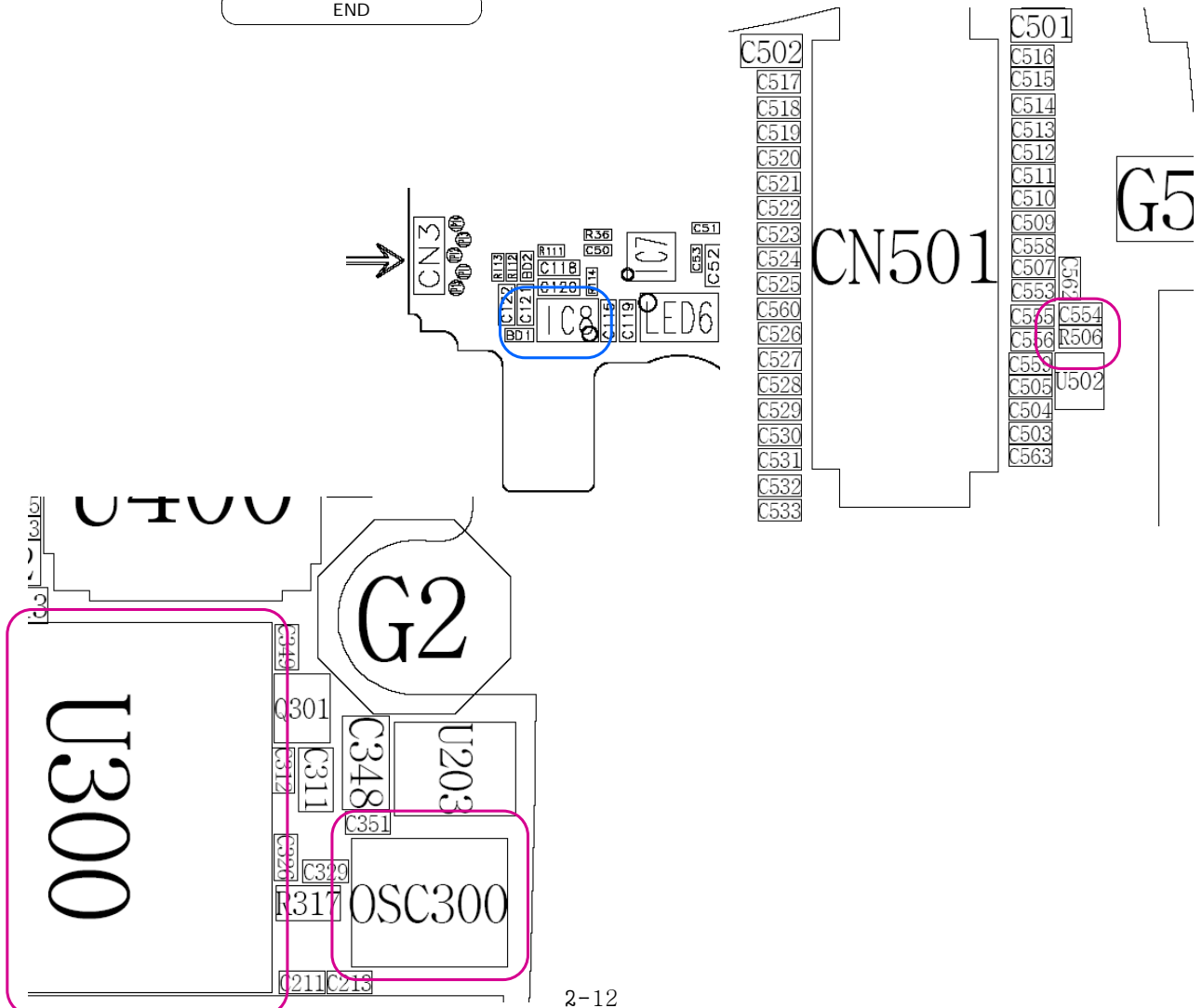
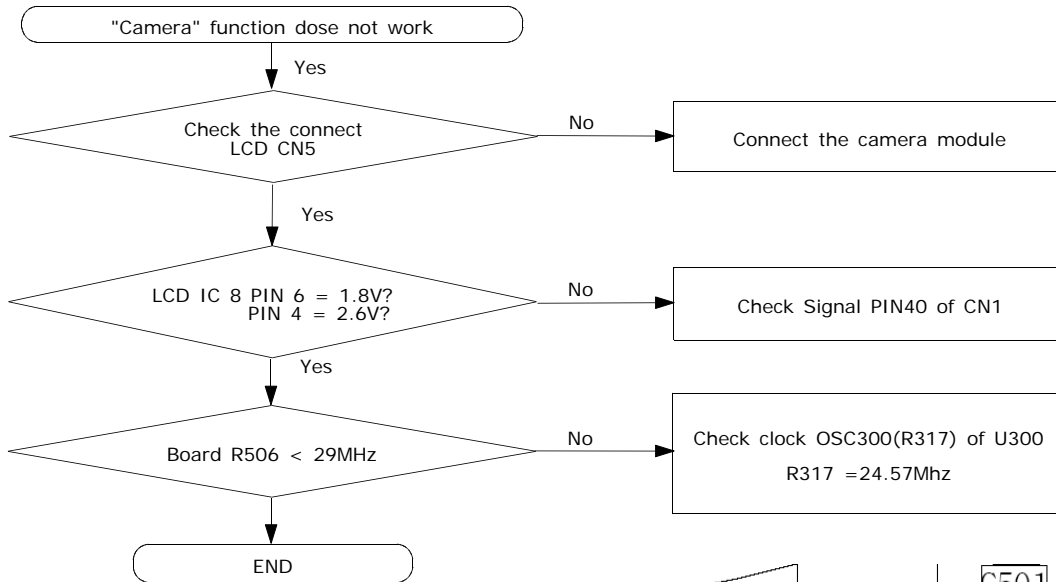

2-1-7. LCD PART

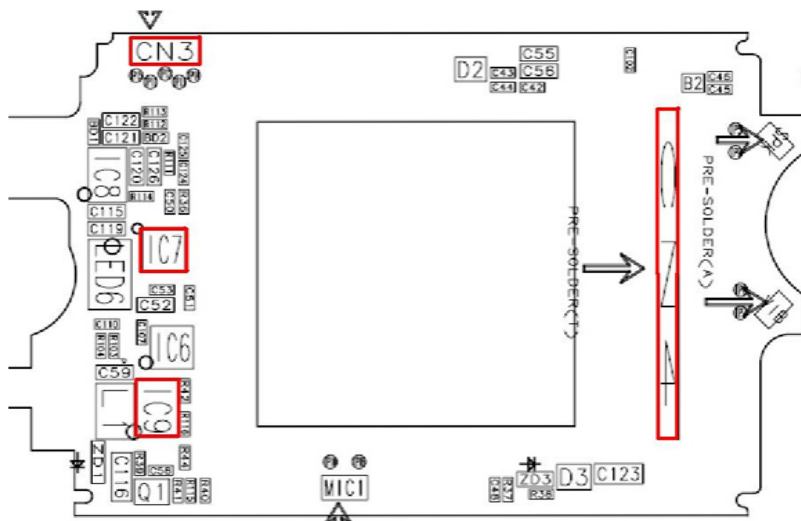
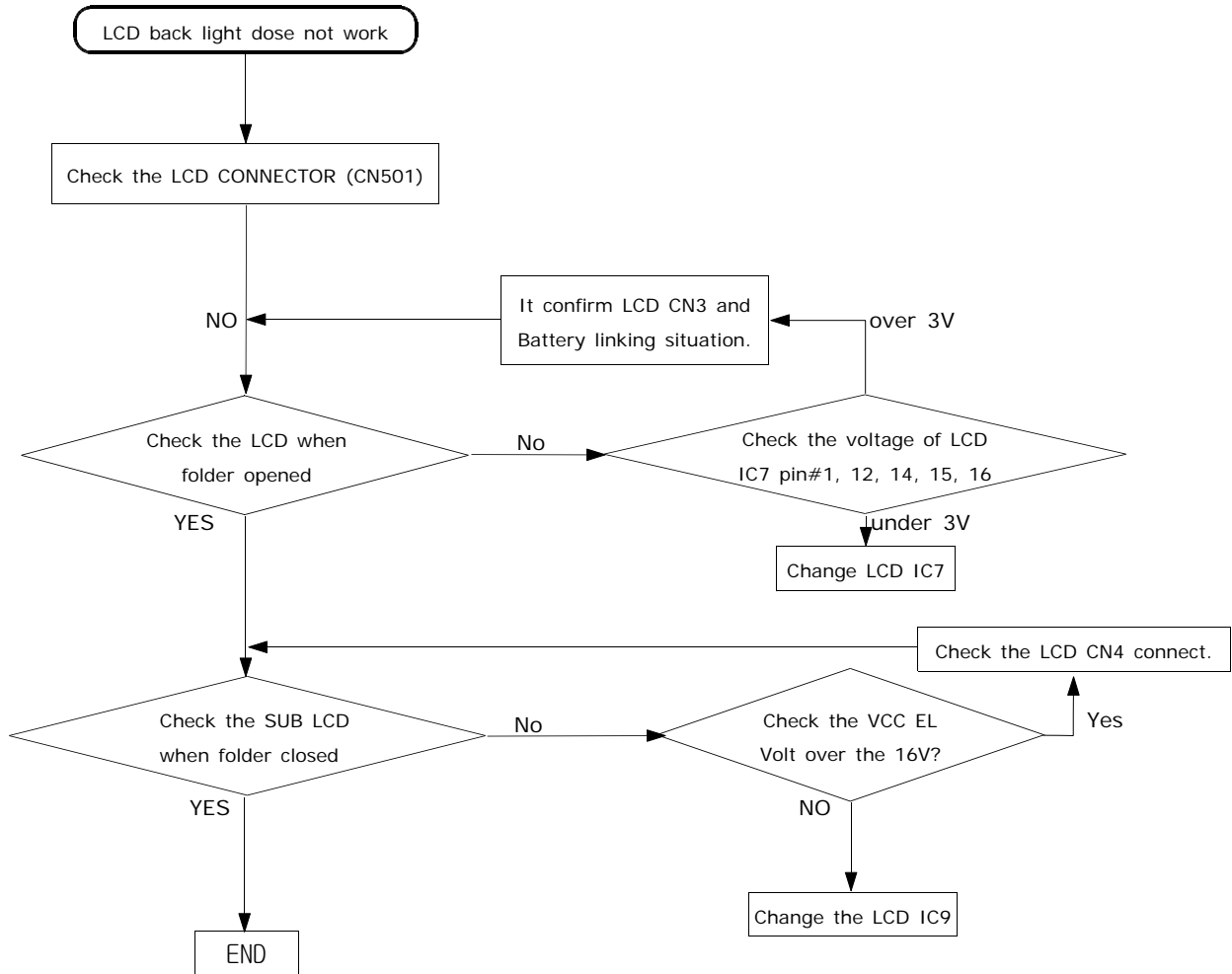



## 2-2.RF

### 2-1-1. EGSM RX

CONTINUOUS RX ON  
RF INPUT : 62CH  
AMP : -50dBm

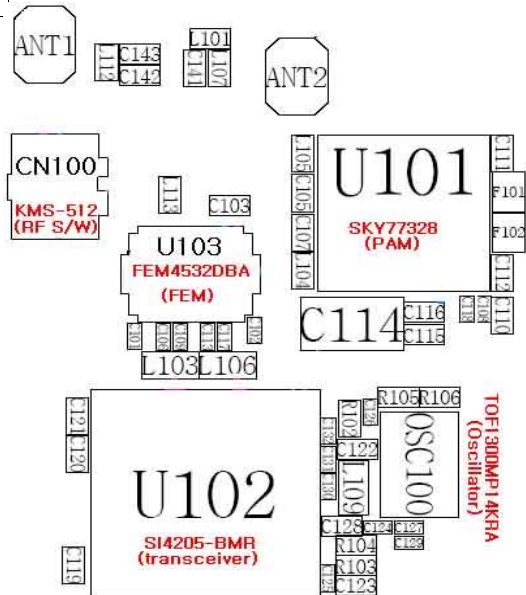
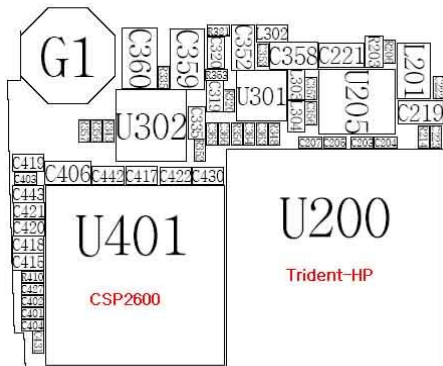
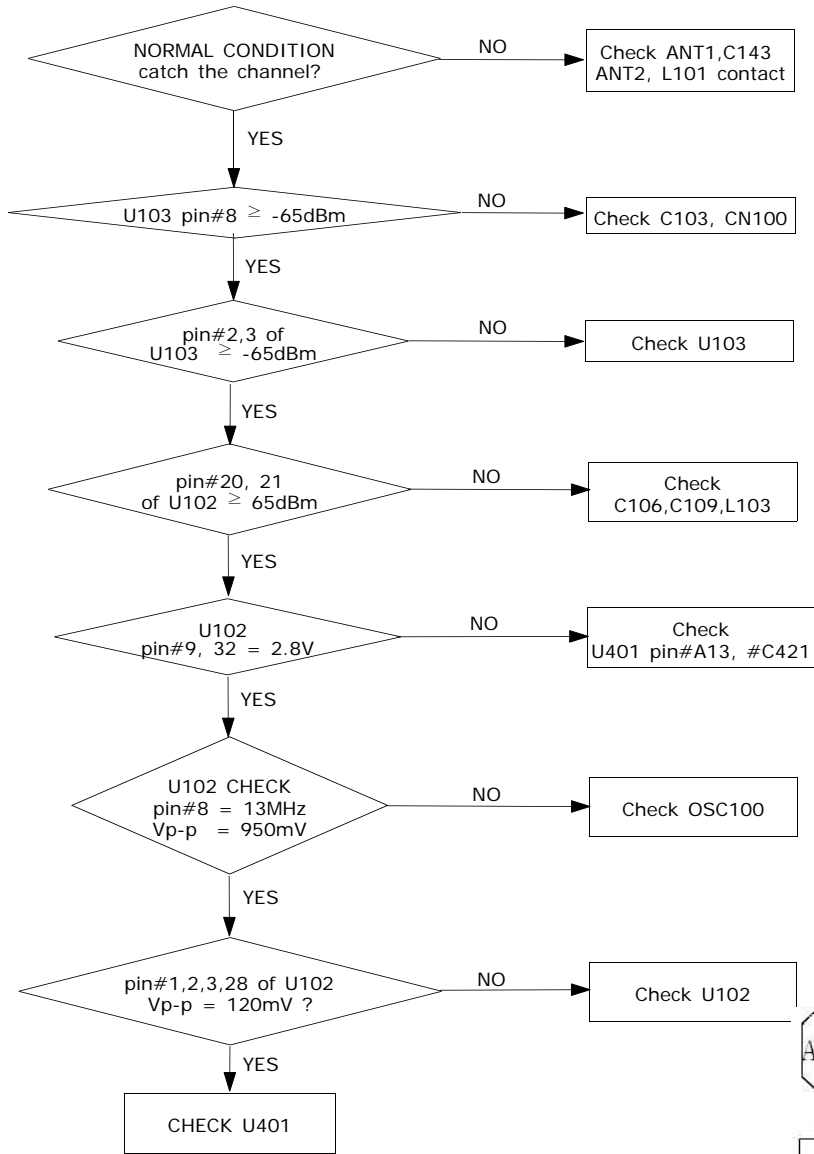

## 2-1-2. DCS RX

CONTINUOUS RX ON  
RF INPUT : 698CH  
AMP : -50dBm

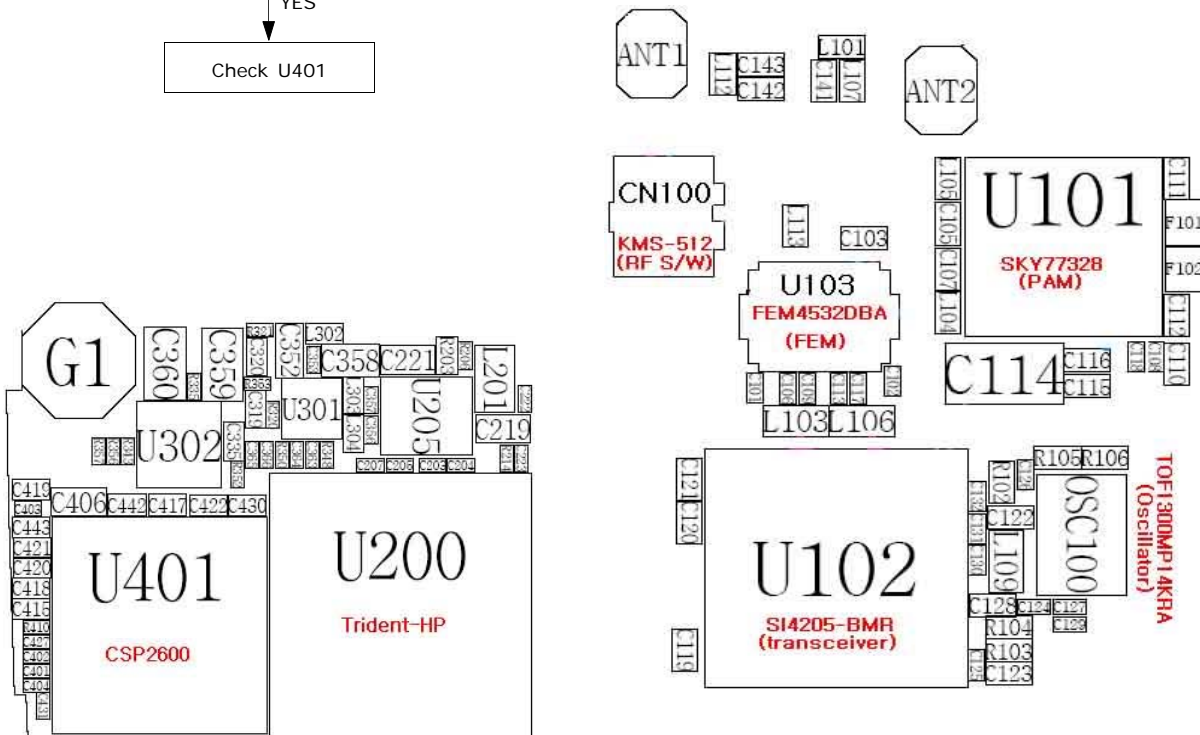
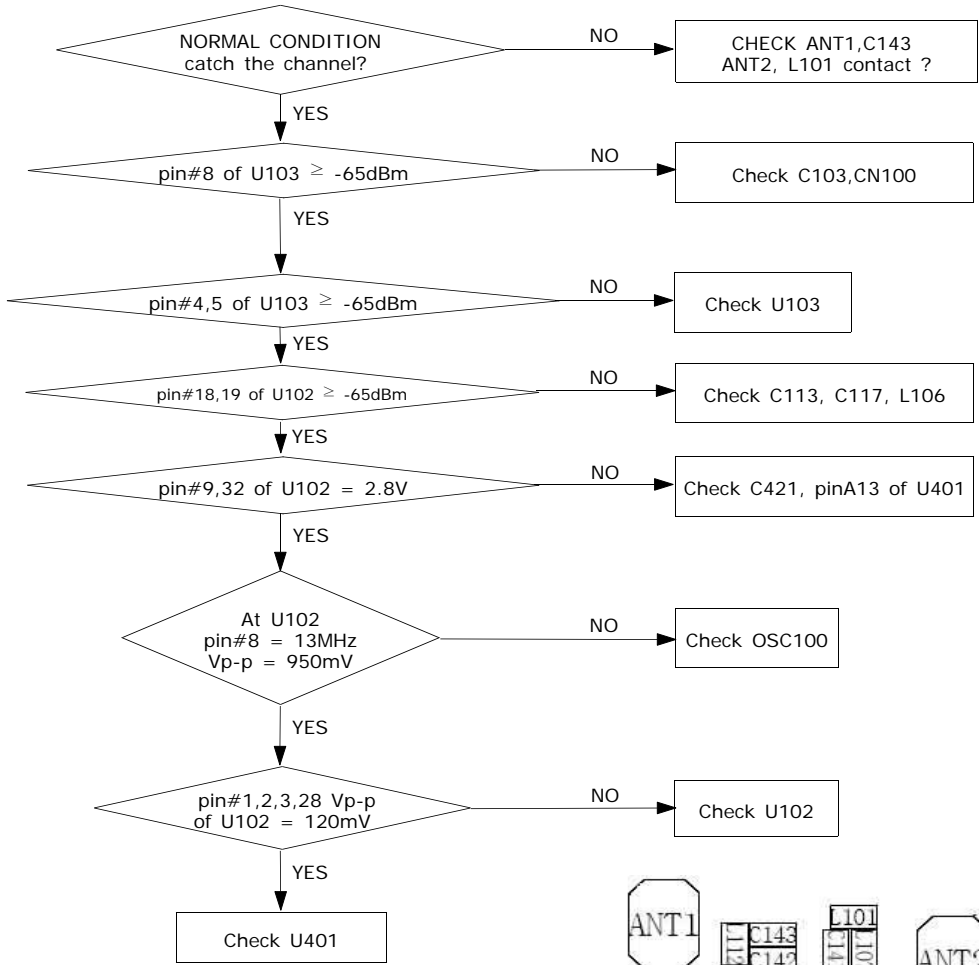

### 2-1-3. EGSM TX

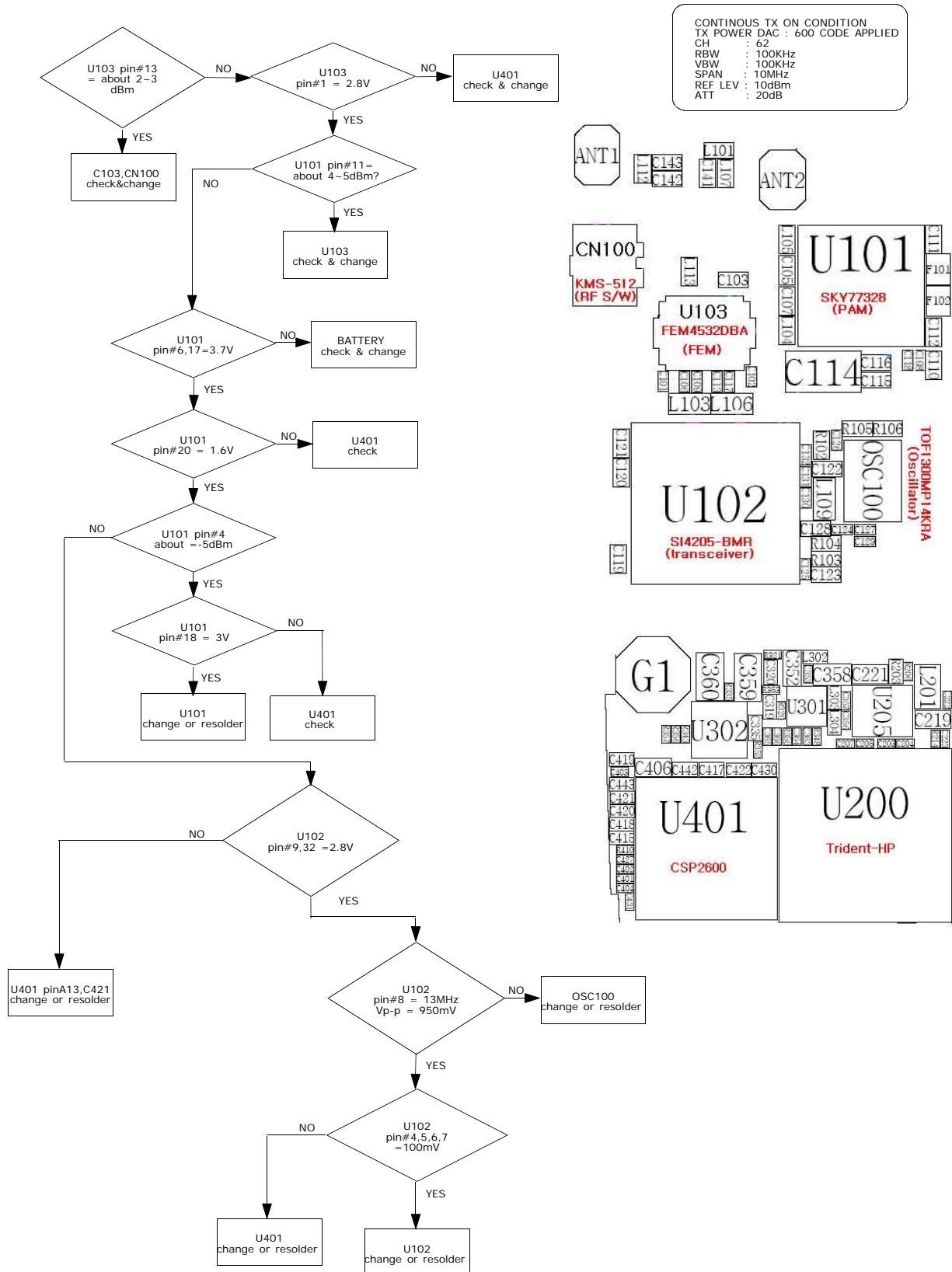

2-1-4. DCS TX

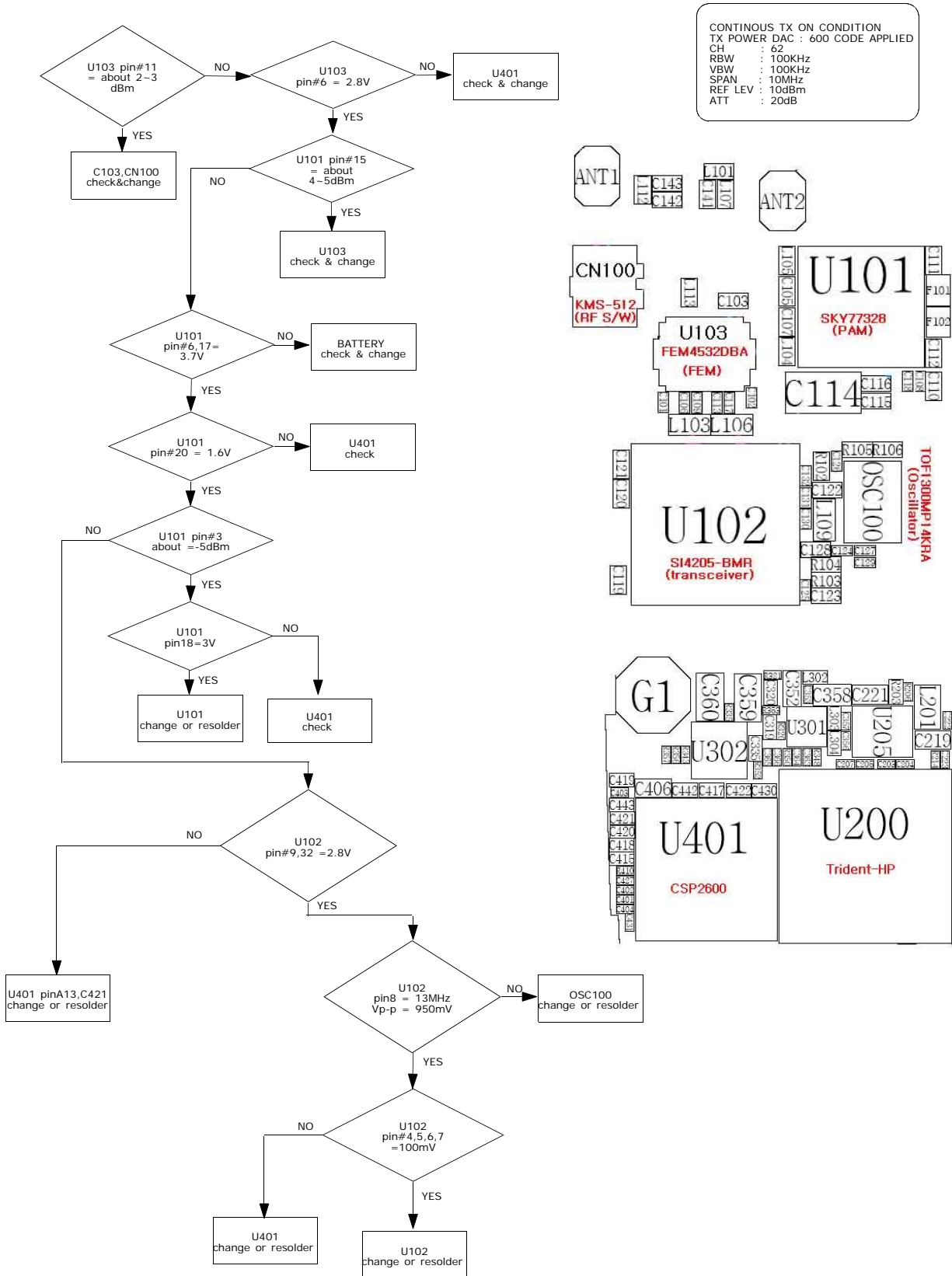

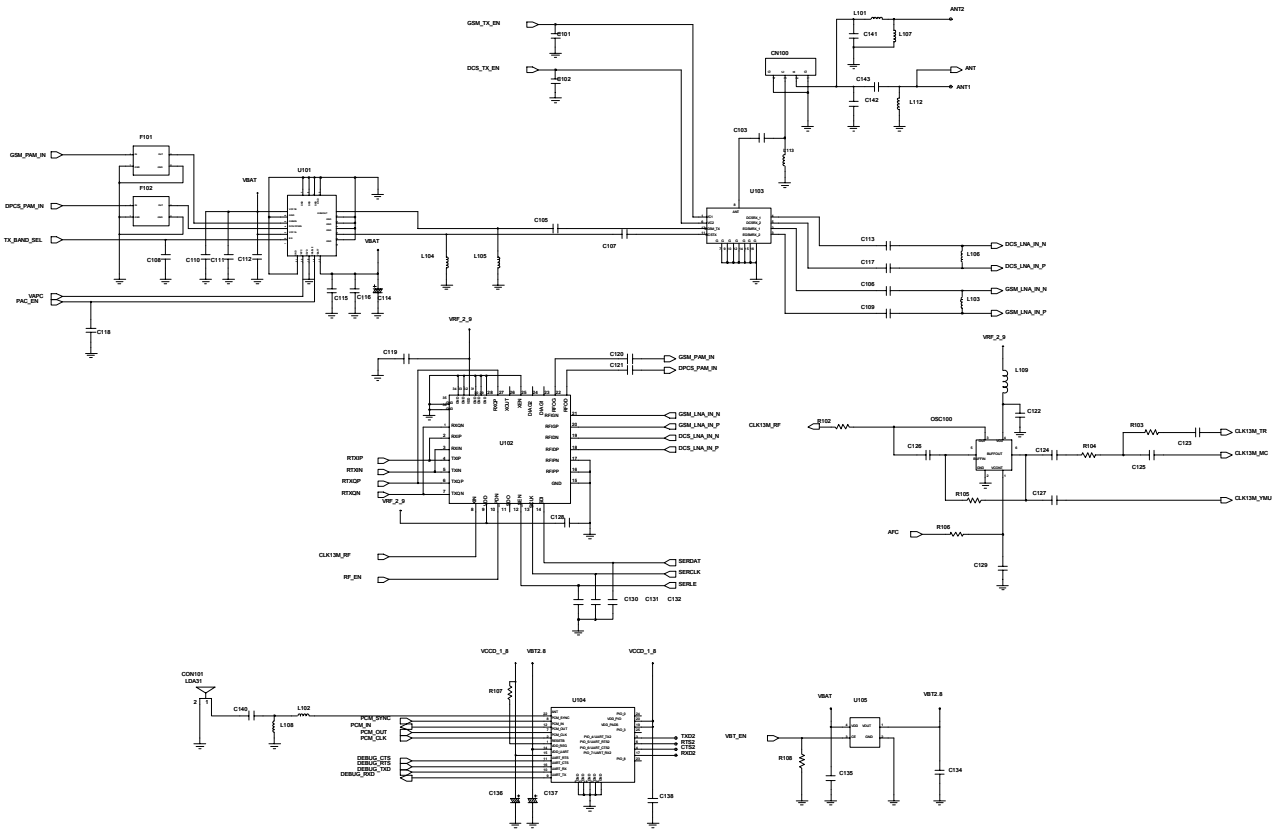

# 3. SGH-E530 Exploded View and Parts List

## 3-1. Cellular phone Exploded View

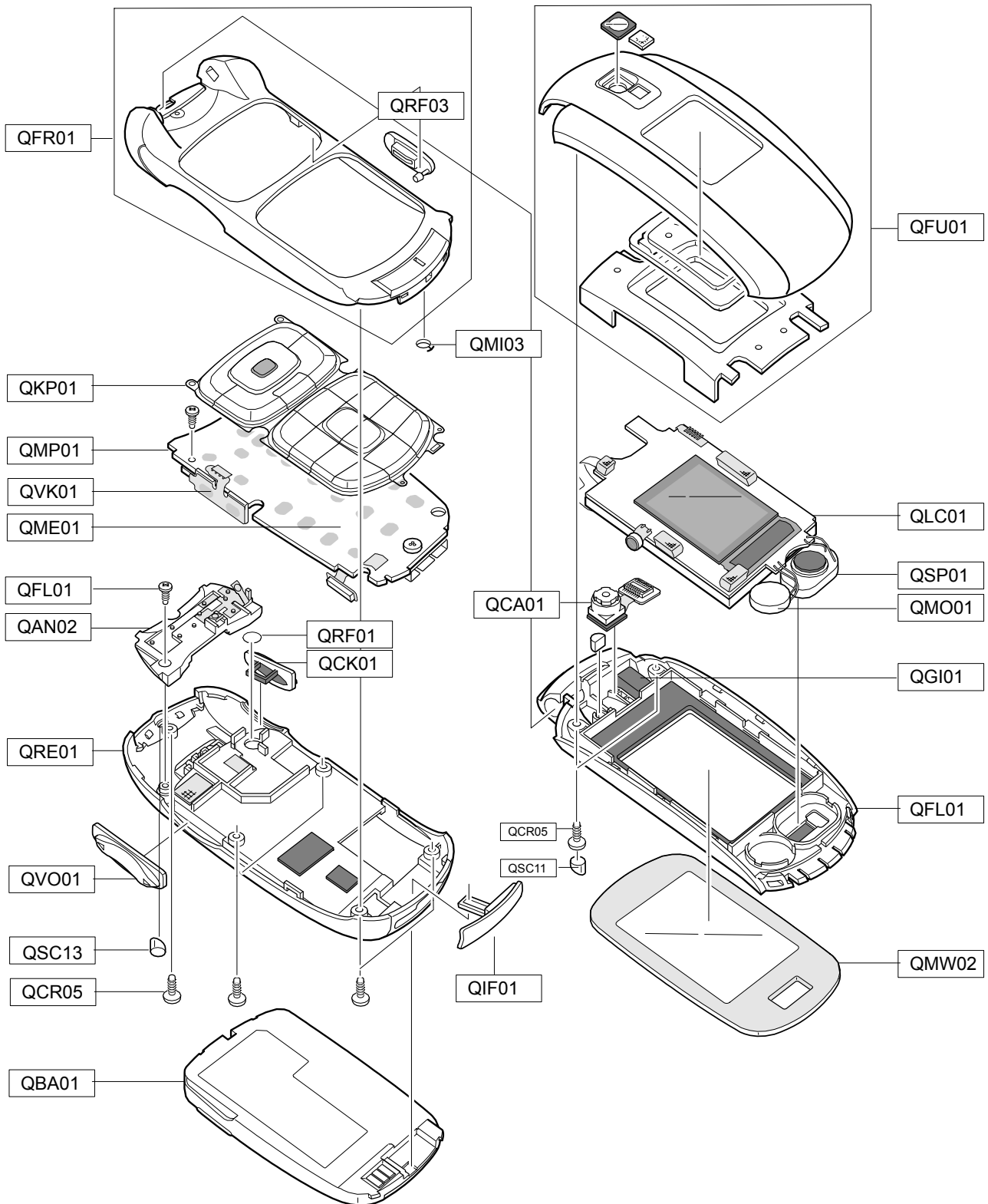

**3-2. Cellular phone Parts list**

Location NO.		Description	SEC CODE	Remark
QFU01		MEC-F/UPPER	GH75-06429A	
QLC01		LCD	GH07-00671A	
QSP01		SPEAKER	3001-001752	
QMO01		MOTOR DC	GH31-00154D	
QCA01		UNIT-CAMERA	GH59-01965A	
QFL01		MEC-F/LOWER	GH75-06428A	
	QGI01	MEC-CUSHION CAMERA FPCB	GH75-06498A	
QCR05		SCREW-MACHINE	6001-001478	
QSC11		RMO-FOLDER SCREW COVER	GH73-04205A	
QMW02		PMO-MAIN WINDOW	GH72-19841A	
QFR01		MEC-FRONT COVER	GH75-06427A	
	QRF03	PMO-EAR JACK COVER V4	GH72-21176A	
	QMI03	MEC-MIC HOLDER	GH75-06696A	
QKP01		MEC-KEYPAD	GH75-06433A	
QMP01		PBA MAIN	GH92-02041A	
QVK01		UNIT-VOLUME KEY	GH59-01963A	
QME01		UNIT-METAL DOME	GH59-01964A	
QAN02		ANTENNA	GH42-00548A	
QRE01		MEC-REAR COVER	GH75-06430A	
QVO01		VOLKEY	GH75-06432A	
QCK01		CAMERA KEY	GH75-07321A	
QIF01		PMO-IF COVER	GH72-20842A	
QBA01		BATTERY	GH43-01760A	
QSC13		RMO-REAR SCREW COVER	GH73-04206A	
QRF01		RF SHEET	GH74-13533A	

Description	SEC CODE
ANTENNA-CHIP; 2400-2484MHz,-,-,4:1,50	4202-001045
BAG PE; LDPE, T0.05, W80, L180, TRP, -, -	6902-000634
CHARGER-SGHE880 TC; TCH237ESE, SGH-E88	GH44-00861A
UNIT-EARPHONE; SGH-X910, AEP277SSE, -, E	GH59-01392A
LABEL(P)-WATER SOAK; SCH-X110, NORGE, 1	GH68-02026A
LABEL(R)-MAIN; SGH-E530, -, MAT, T0.1, 32	GH68-06868A
MANUAL-USE; SGH-E530, XEF, FRENCH, FRAN,	GH68-06998A
MANUAL-WEEE CARD; SGH-E720, SEC, ENGLIS	GH68-07013A
CUSHION-CASE; SGH-E530, PULP, T1.0, 179,	GH69-02895A
BOX(P)-UNIT MAIN; SGH-E530, SC300+F(KO	GH69-02896A
NDC-VOL KEY BRACKET; -, SGH-E530, ZN, -,	GH71-04736A
RMO-INTENNA RUBBER; SGH-E530, CR RUBBE	GH73-04778A
MPR-LCD BOHO VINYL; SCH-X290, VINYL, 58	GH74-02119A
MPR-VINYL MAIN LCD; SGH-E700, STA ELEC	GH74-05968A
MPR-TAPE LCD FPCB; SGH-E530, 3M 1352 B	GH74-14288A
MPR-GASKET LCD A; SGH-E530, GASKET, 5X3	GH74-14289A
MPR-GASKET LCD B; SGH-E530, GASKET, 9X3	GH74-14290A
MPR-GASKET LCD C; SGH-E530, GASKET, 3X3	GH74-14291A
MPR-PORON LCD CONN; SGH-E530, SRS PORO	GH74-14292A
MPR-TAPE HALL SENSOR; SGH-E530, 3M 851	GH74-14295A
MPR-TAPE SIDE KEY; SGH-E530, 3M 851, 5X	GH74-14296A
MPR-TAPE PBA; SGH-E530, DTF 100, 5X2X0.	GH74-14298A
MPR-BOHO VINYL UPPER B; SGH-E530, SP30	GH74-14773A
MPR-TAPE MIC PART; SGH-E530, 3M 851, 7.	GH74-15505A
MEC-HAND STRAP; SGH-E530, XEF, AU, -, -, -	GH75-07201A
MEC-CARRING CASE; SGH-E530, XEF, PVC, -, -	GH75-07202A



### 3-3. Test Jig (GH80-03307A)



3-3-1. RF Test Cable  
(GH39-00283A)



3-3-2. Test Cable  
(GH39-00389A)



3-3-3. Serial Cable



3-3-4. Power Supply Cable



3-3-6. TC  
(GH44-00861A)



## 4. SGH-E530 MAIN Electrical Parts List

SEC Code	Design LOC	Discription
0403-001387	ZD504	DIODE-ZENER
0403-001446	ZD505	DIODE-ZENER
0406-001197	ZD502	DIODE-TVS
0406-001197	ZD503	DIODE-TVS
0504-001138	Q301	TR-DIGITAL
0504-001140	Q201	TR-DIGITAL
0601-001819	LED401	LED
0601-001819	LED402	LED
0601-001819	LED403	LED
0601-001819	LED404	LED
0601-001819	LED405	LED
0601-001819	LED406	LED
0601-001819	LED408	LED
0601-001819	LED409	LED
0601-001819	LED410	LED
0601-001819	LED411	LED
0601-001819	LED413	LED
0601-001819	LED414	LED
0601-001819	LED415	LED
0601-001819	LED416	LED
0601-001819	LED417	LED
0601-001819	LED418	LED
0601-001819	LED419	LED
0601-001819	LED420	LED
0801-002529	U203	IC-CMOS LOGIC
0801-002970	U502	IC-CMOS LOGIC
1001-001306	U302	IC-ANALOG MULTIPLEX
1009-001020	U201	IC-HALL EFFECT S/W
1108-000003	U202	IC-MCP
1201-002218	U101	IC-POWER AMP
1201-002233	U301	IC-AUDIO AMP
1203-002625	U105	IC-POSI.FIXED REG.
1203-003472	U401	IC-POWER SUPERVISOR
1203-003616	U304	IC-DC/DC CONVERTER
1203-003629	U501	IC-POSI.FIXED REG.
1203-003667	U205	IC-DC/DC CONVERTER
1203-003730	U306	IC-POSI.FIXED REG.
1204-002138	U400	IC-MELODY
1205-002272	U406	IC-TRANSCEIVER
1205-002433	U102	IC-TRANSCEIVER
1205-002612	U300	IC-CODEC

SEC Code	Design LOC	Discription
1205-002613	U303	IC-CODEC
1404-001165	TH101	THERMISTOR-NTC
1405-001082	V401	VARISTOR
1405-001082	V402	VARISTOR
1405-001082	V403	VARISTOR
1405-001082	V404	VARISTOR
2007-000138	R102	R-CHIP
2007-000138	R311	R-CHIP
2007-000141	R103	R-CHIP
2007-000148	R106	R-CHIP
2007-000151	R204	R-CHIP
2007-000155	R203	R-CHIP
2007-000162	R105	R-CHIP
2007-000162	R305	R-CHIP
2007-000170	R317	R-CHIP
2007-001291	R444	R-CHIP
2007-001291	R445	R-CHIP
2007-001307	R446	R-CHIP
2007-001307	R447	R-CHIP
2007-001307	R448	R-CHIP
2007-001307	R449	R-CHIP
2007-001307	R450	R-CHIP
2007-001307	R451	R-CHIP
2007-001307	R452	R-CHIP
2007-001307	R453	R-CHIP
2007-001307	R454	R-CHIP
2007-001307	R455	R-CHIP
2007-001307	R456	R-CHIP
2007-001307	R457	R-CHIP
2007-001307	R458	R-CHIP
2007-001307	R459	R-CHIP
2007-001307	R460	R-CHIP
2007-001307	R461	R-CHIP
2007-001307	R462	R-CHIP
2007-001307	R463	R-CHIP
2007-001319	R331	R-CHIP
2007-001323	R107	R-CHIP
2007-001325	R406	R-CHIP
2007-002797	R104	R-CHIP
2007-007528	R443	R-CHIP
2007-008045	R408	R-CHIP
2007-008052	R410	R-CHIP
2007-008054	R348	R-CHIP

SGH-E530 Main Electrical Parts List

SEC Code	Design LOC	Discription
2007-008054	R350	R-CHIP
2007-008055	R108	R-CHIP
2007-008055	R202	R-CHIP
2007-008055	R208	R-CHIP
2007-008055	R213	R-CHIP
2007-008055	R357	R-CHIP
2007-008419	R511	R-CHIP
2007-008419	R512	R-CHIP
2007-008419	R513	R-CHIP
2007-008419	R522	R-CHIP
2007-008483	R205	R-CHIP
2007-008483	R401	R-CHIP
2007-008516	R214	R-CHIP
2007-008516	R314	R-CHIP
2007-008516	R325	R-CHIP
2007-008516	R327	R-CHIP
2007-008516	R334	R-CHIP
2007-008516	R338	R-CHIP
2007-008516	R407	R-CHIP
2007-008531	R319	R-CHIP
2007-008531	R320	R-CHIP
2007-008531	R321	R-CHIP
2007-008531	R335	R-CHIP
2007-008531	R343	R-CHIP
2007-008531	R352	R-CHIP
2007-008531	R353	R-CHIP
2007-008531	R506	R-CHIP
2007-008542	R345	R-CHIP
2007-008542	R356	R-CHIP
2007-008548	R323	R-CHIP
2007-008548	R404	R-CHIP
2007-008549	R526	R-CHIP
2007-008588	R308	R-CHIP
2007-008588	R324	R-CHIP
2007-008588	R328	R-CHIP
2007-008588	R333	R-CHIP
2007-008588	R342	R-CHIP
2007-008808	R209	R-CHIP
2007-008808	R354	R-CHIP
2007-008808	R355	R-CHIP
2007-009158	R210	R-CHIP
2007-009166	R405	R-CHIP
2007-009166	R413	R-CHIP

SEC Code	Design LOC	Discription
2007-009167	R414	R-CHIP
2007-009168	R206	R-CHIP
2007-009168	R337	R-CHIP
2007-009168	R341	R-CHIP
2007-009169	R402	R-CHIP
2007-009169	R403	R-CHIP
2011-001363	F101	R-NET
2011-001363	F102	R-NET
2203-000233	C110	C-CER,CHIP
2203-000233	C115	C-CER,CHIP
2203-000233	C417	C-CER,CHIP
2203-000254	C111	C-CER,CHIP
2203-000254	C116	C-CER,CHIP
2203-000330	C107	C-CER,CHIP
2203-000425	C123	C-CER,CHIP
2203-000628	C143	C-CER,CHIP
2203-000812	C121	C-CER,CHIP
2203-000995	C103	C-CER,CHIP
2203-000995	C120	C-CER,CHIP
2203-001239	C340	C-CER,CHIP
2203-001239	C341	C-CER,CHIP
2203-001259	C105	C-CER,CHIP
2203-001405	C128	C-CER,CHIP
2203-005061	C119	C-CER,CHIP
2203-005446	C140	C-CER,CHIP
2203-005482	C112	C-CER,CHIP
2203-005482	C122	C-CER,CHIP
2203-005482	C138	C-CER,CHIP
2203-005496	C319	C-CER,CHIP
2203-005496	C320	C-CER,CHIP
2203-005682	C108	C-CER,CHIP
2203-005682	C118	C-CER,CHIP
2203-005682	C222	C-CER,CHIP
2203-005682	C331	C-CER,CHIP
2203-005682	C351	C-CER,CHIP
2203-005682	C356	C-CER,CHIP
2203-005682	C357	C-CER,CHIP
2203-005682	C368	C-CER,CHIP
2203-005682	C405	C-CER,CHIP
2203-005682	C409	C-CER,CHIP
2203-005682	C410	C-CER,CHIP
2203-005682	C503	C-CER,CHIP
2203-005682	C504	C-CER,CHIP

SEC Code	Design LOC	Discription
2203-005682	C505	C-CER,CHIP
2203-005682	C506	C-CER,CHIP
2203-005682	C507	C-CER,CHIP
2203-005682	C508	C-CER,CHIP
2203-005682	C509	C-CER,CHIP
2203-005682	C510	C-CER,CHIP
2203-005682	C511	C-CER,CHIP
2203-005682	C512	C-CER,CHIP
2203-005682	C513	C-CER,CHIP
2203-005682	C514	C-CER,CHIP
2203-005682	C515	C-CER,CHIP
2203-005682	C516	C-CER,CHIP
2203-005682	C517	C-CER,CHIP
2203-005682	C518	C-CER,CHIP
2203-005682	C519	C-CER,CHIP
2203-005682	C520	C-CER,CHIP
2203-005682	C521	C-CER,CHIP
2203-005682	C522	C-CER,CHIP
2203-005682	C523	C-CER,CHIP
2203-005682	C524	C-CER,CHIP
2203-005682	C525	C-CER,CHIP
2203-005682	C526	C-CER,CHIP
2203-005682	C527	C-CER,CHIP
2203-005682	C528	C-CER,CHIP
2203-005682	C529	C-CER,CHIP
2203-005682	C530	C-CER,CHIP
2203-005682	C531	C-CER,CHIP
2203-005682	C532	C-CER,CHIP
2203-005682	C533	C-CER,CHIP
2203-005682	C553	C-CER,CHIP
2203-005682	C554	C-CER,CHIP
2203-005682	C555	C-CER,CHIP
2203-005682	C558	C-CER,CHIP
2203-005682	C559	C-CER,CHIP
2203-005682	C560	C-CER,CHIP
2203-005683	C556	C-CER,CHIP
2203-005731	C216	C-CER,CHIP
2203-005731	C217	C-CER,CHIP
2203-005736	C101	C-CER,CHIP
2203-005736	C102	C-CER,CHIP
2203-005736	C125	C-CER,CHIP
2203-005736	C130	C-CER,CHIP
2203-005736	C131	C-CER,CHIP

SEC Code	Design LOC	Discription
2203-005736	C132	C-CER,CHIP
2203-005806	C339	C-CER,CHIP
2203-005806	C344	C-CER,CHIP
2203-005806	C426	C-CER,CHIP
2203-006053	C135	C-CER,CHIP
2203-006053	C541	C-CER,CHIP
2203-006093	C301	C-CER,CHIP
2203-006093	C302	C-CER,CHIP
2203-006093	C305	C-CER,CHIP
2203-006093	C307	C-CER,CHIP
2203-006093	C311	C-CER,CHIP
2203-006093	C313	C-CER,CHIP
2203-006093	C324	C-CER,CHIP
2203-006093	C335	C-CER,CHIP
2203-006093	C346	C-CER,CHIP
2203-006093	C350	C-CER,CHIP
2203-006093	C361	C-CER,CHIP
2203-006093	C362	C-CER,CHIP
2203-006093	C407	C-CER,CHIP
2203-006093	C415	C-CER,CHIP
2203-006093	C418	C-CER,CHIP
2203-006093	C419	C-CER,CHIP
2203-006093	C420	C-CER,CHIP
2203-006093	C421	C-CER,CHIP
2203-006093	C422	C-CER,CHIP
2203-006093	C430	C-CER,CHIP
2203-006093	C442	C-CER,CHIP
2203-006093	C443	C-CER,CHIP
2203-006093	C501	C-CER,CHIP
2203-006093	C502	C-CER,CHIP
2203-006093	C557	C-CER,CHIP
2203-006137	C342	C-CER,CHIP
2203-006190	C330	C-CER,CHIP
2203-006190	C332	C-CER,CHIP
2203-006190	C337	C-CER,CHIP
2203-006190	C338	C-CER,CHIP
2203-006194	C124	C-CER,CHIP
2203-006194	C126	C-CER,CHIP
2203-006194	C127	C-CER,CHIP
2203-006194	C129	C-CER,CHIP
2203-006194	C202	C-CER,CHIP
2203-006194	C203	C-CER,CHIP
2203-006194	C207	C-CER,CHIP

SGH-E530 Main Electrical Parts List

SEC Code	Design LOC	Discription
2203-006194	C209	C-CER,CHIP
2203-006194	C210	C-CER,CHIP
2203-006194	C213	C-CER,CHIP
2203-006194	C223	C-CER,CHIP
2203-006194	C402	C-CER,CHIP
2203-006194	C403	C-CER,CHIP
2203-006194	C457	C-CER,CHIP
2203-006194	C552	C-CER,CHIP
2203-006201	C134	C-CER,CHIP
2203-006201	C406	C-CER,CHIP
2203-006208	C219	C-CER,CHIP
2203-006208	C221	C-CER,CHIP
2203-006208	C322	C-CER,CHIP
2203-006208	C323	C-CER,CHIP
2203-006208	C348	C-CER,CHIP
2203-006208	C352	C-CER,CHIP
2203-006257	C423	C-CER,CHIP
2203-006305	C326	C-CER,CHIP
2203-006305	C329	C-CER,CHIP
2203-006318	C106	C-CER,CHIP
2203-006318	C109	C-CER,CHIP
2203-006318	C113	C-CER,CHIP
2203-006318	C117	C-CER,CHIP
2203-006379	C321	C-CER,CHIP
2203-006379	C561	C-CER,CHIP
2203-006379	C562	C-CER,CHIP
2203-006379	C563	C-CER,CHIP
2203-006423	C201	C-CER,CHIP
2203-006423	C204	C-CER,CHIP
2203-006423	C205	C-CER,CHIP
2203-006423	C208	C-CER,CHIP
2203-006423	C211	C-CER,CHIP
2203-006423	C212	C-CER,CHIP
2203-006423	C214	C-CER,CHIP
2203-006423	C218	C-CER,CHIP
2203-006423	C304	C-CER,CHIP
2203-006423	C309	C-CER,CHIP
2203-006423	C312	C-CER,CHIP
2203-006423	C314	C-CER,CHIP
2203-006423	C317	C-CER,CHIP
2203-006423	C325	C-CER,CHIP
2203-006423	C347	C-CER,CHIP
2203-006423	C349	C-CER,CHIP

SEC Code	Design LOC	Discription
2203-006423	C353	C-CER,CHIP
2203-006423	C367	C-CER,CHIP
2203-006423	C401	C-CER,CHIP
2203-006423	C404	C-CER,CHIP
2203-006423	C408	C-CER,CHIP
2203-006423	C413	C-CER,CHIP
2203-006423	C416	C-CER,CHIP
2203-006423	C425	C-CER,CHIP
2203-006423	C431	C-CER,CHIP
2203-006423	C458	C-CER,CHIP
2203-006423	C499	C-CER,CHIP
2203-006556	C220	C-CER,CHIP
2203-006638	C414	C-CER,CHIP
2203-006648	C206	C-CER,CHIP
2203-006648	C363	C-CER,CHIP
2203-006648	C364	C-CER,CHIP
2203-006648	C365	C-CER,CHIP
2203-006648	C366	C-CER,CHIP
2203-006648	C427	C-CER,CHIP
2203-006648	C456	C-CER,CHIP
2203-006668	C432	C-CER,CHIP
2203-006668	C433	C-CER,CHIP
2203-006668	C434	C-CER,CHIP
2203-006668	C435	C-CER,CHIP
2203-006668	C436	C-CER,CHIP
2203-006668	C437	C-CER,CHIP
2203-006668	C438	C-CER,CHIP
2203-006668	C439	C-CER,CHIP
2203-006668	C440	C-CER,CHIP
2203-006668	C441	C-CER,CHIP
2203-006712	C411	C-CER,CHIP
2404-001226	C318	C-TA,CHIP
2404-001274	C114	C-TA,CHIP
2404-001306	C551	C-TA,CHIP
2404-001380	C359	C-TA,CHIP
2404-001380	C360	C-TA,CHIP
2404-001381	C136	C-TA,CHIP
2404-001381	C137	C-TA,CHIP
2404-001381	C310	C-TA,CHIP
2404-001381	C327	C-TA,CHIP
2404-001381	C328	C-TA,CHIP
2404-001381	C334	C-TA,CHIP
2404-001381	C358	C-TA,CHIP

SEC Code	Design LOC	Discription
2404-001381	C412	C-TA,CHIP
2404-001381	C424	C-TA,CHIP
2703-001728	L102	INDUCTOR-SMD
2703-001729	L108	INDUCTOR-SMD
2703-001907	L103	INDUCTOR-SMD
2703-001990	L112	INDUCTOR-SMD
2703-002198	L107	INDUCTOR-SMD
2703-002200	L105	INDUCTOR-SMD
2703-002269	L104	INDUCTOR-SMD
2703-002269	L113	INDUCTOR-SMD
2703-002547	L106	INDUCTOR-SMD
2703-002734	L201	INDUCTOR-SMD
2703-002734	L301	INDUCTOR-SMD
2801-004225	OSC300	CRYSTAL-SMD
2801-004373	OSC200	CRYSTAL-SMD
2809-001284	OSC100	OSCILLATOR-VCTCXO
2911-000006	U103	DUPLEXER-FEM
3003-001107	MIC300	MIC-CONDENSOR
3301-001105	L109	CORE-FERRITE
3301-001342	L200	BEAD-SMD
3301-001729	L302	BEAD-SMD
3301-001787	L303	CORE-FERRITE BEAD
3301-001787	L304	CORE-FERRITE BEAD
3404-001152	CAM_KEY	SWITCH-TACT
3705-001358	CN100	CONNECTOR-COAXIAL
3709-001298	CN400	CONNECTOR-CARD EDGE
3710-002225	CN502	CONNECTOR-INTERFACE
3711-005781	CN507	CONNECTOR-BATTERY
3711-005890	CN501	CONNECTOR-HEADER
3722-002010	CN301	JACK-EAR PHONE
4302-001158	M400	BATTERY-LI(2ND)
4709-001350	U104	BLUETOOTH MODULE
GH09-00033A	U200	IC MICOM-SGHE720
GH41-00788A		PCB MAIN-SGHE530
GH96-01767A		ELA UNIT-SGHE530
4202-001045		ANTENNA-CHIP
6001-001478		SCREW-MACHINE
GH59-01963A		UNIT-VOLUME KEY
GH59-01964A		UNIT-METAL DOME

SEC Code	Design LOC	Discription
GH71-04736A		NDC-VOL KEY BRACKET
GH74-14295A		MPR-TAPE HALL SENSOR
GH74-14296A		MPR-TAPE SIDE KEY
GH74-14298A		MPR-TAPE PBA

---

## 5. SGH-E530 PCB Diagrams

---

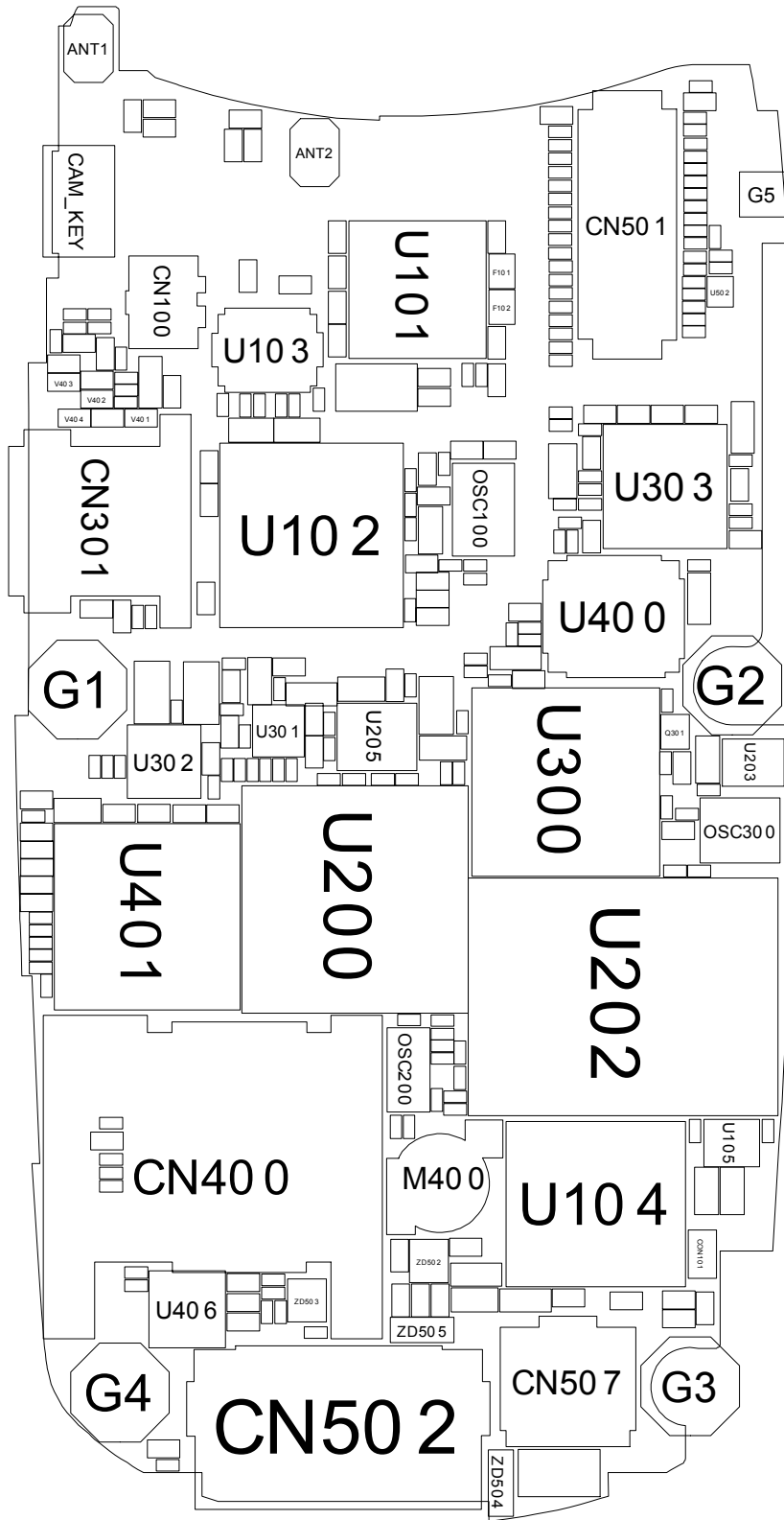

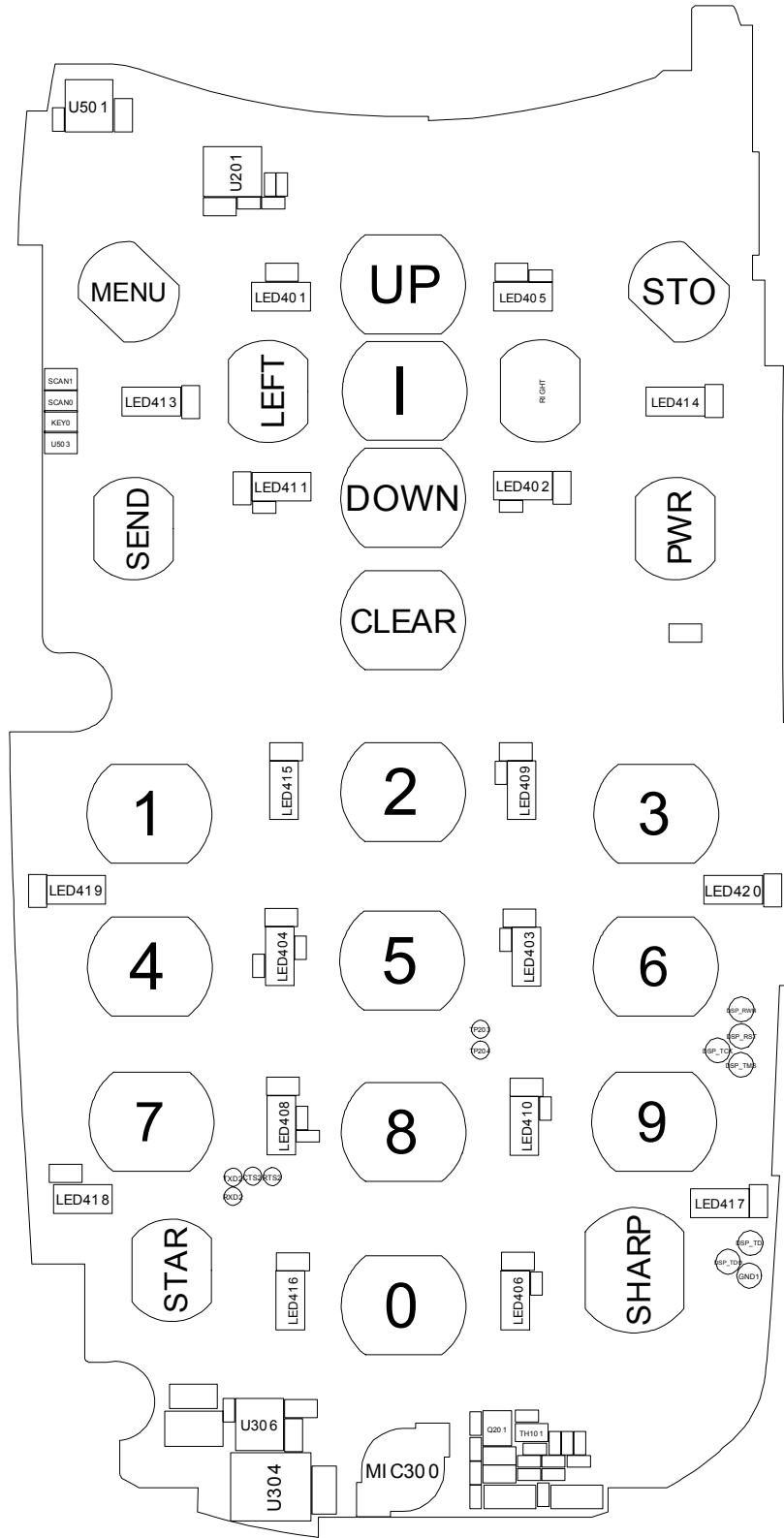



# 6. SGH-E530 Block Diagrams

## 6-1. RF Solution Block Diagram

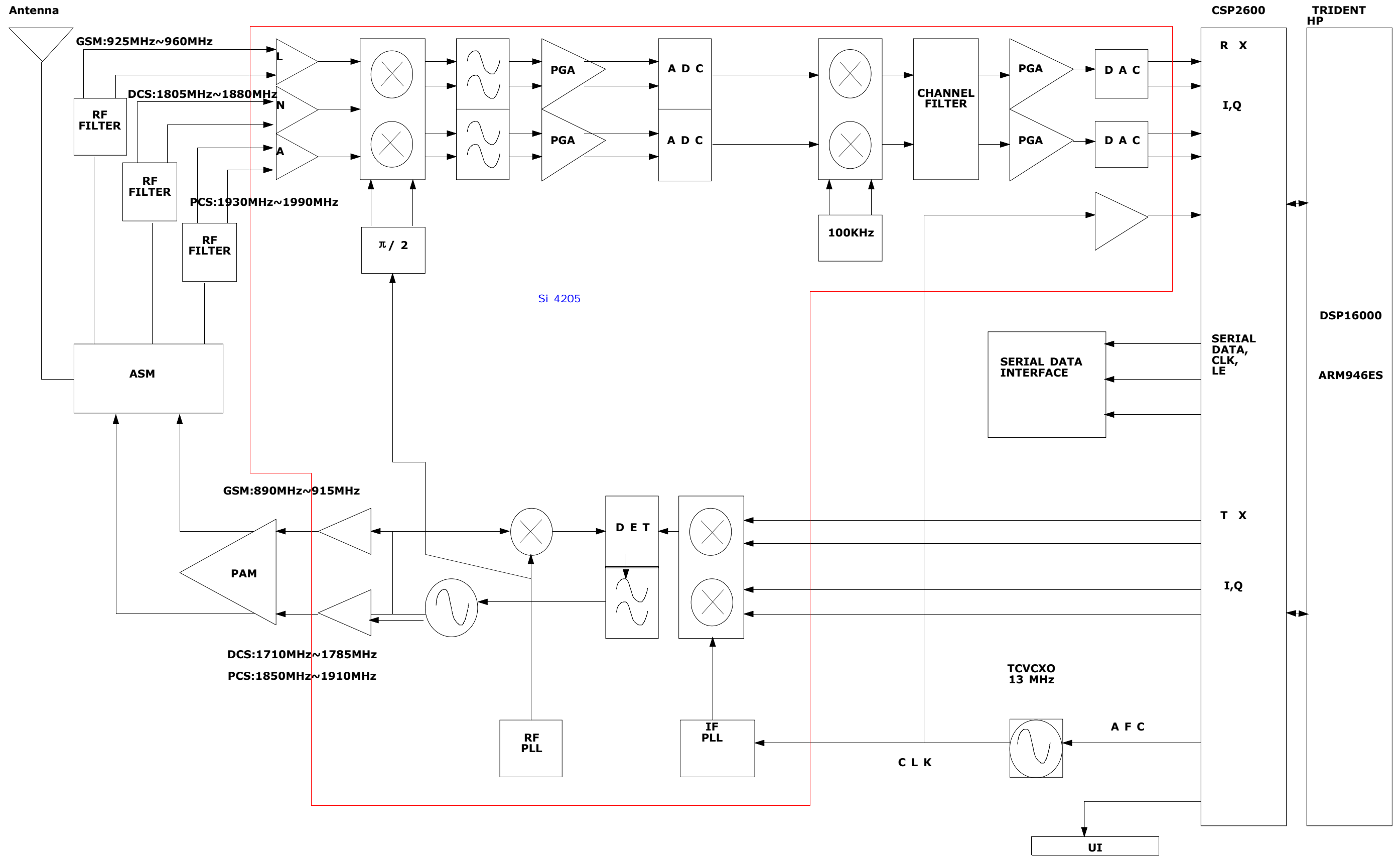

## 6-2. Base Band Solution Block Diagram

