

Engineer	COMPANY NAME
Drawn By	Address
REV. CHK	TITLE: SGH-E 300
DOC. CTRL. CHK	Size 8.0
REV. ENDR. CHK	

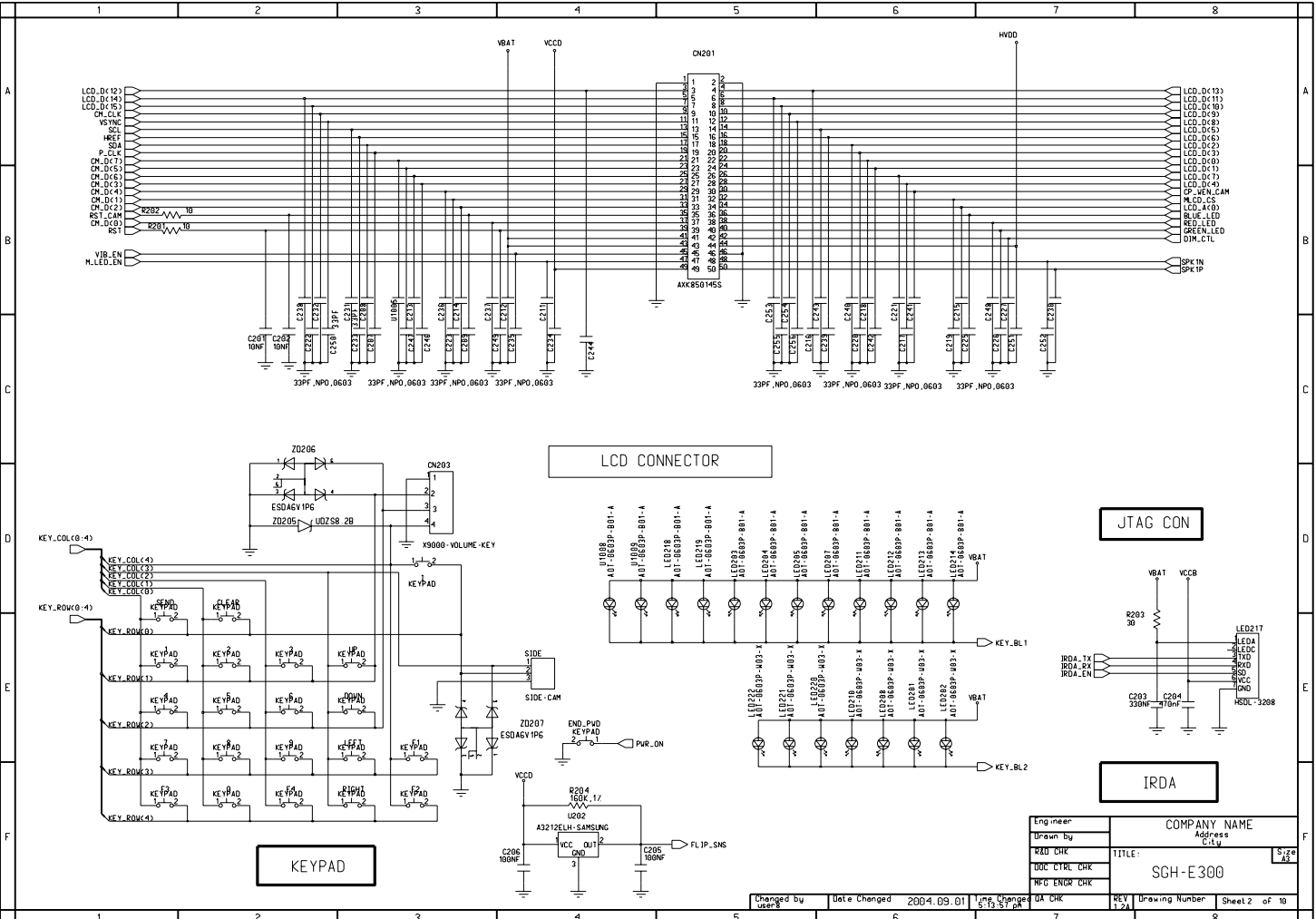

LCD CONNECTOR

JTAG CON

KEYPAD

IRDA

Eng. mear	COMPANY NAME
Drawn By	Address
REV CHK	TITLE:
DOC. CTRL. CHK	SGH-E 300
NUO ENDS CHK	Size
	8A
Changed by	Date changed
user8	2004.09.01
	Eng. changed
	DA CHK
	7
	REV 1.2A
	Drawing Number
	Sheet 2 of 10

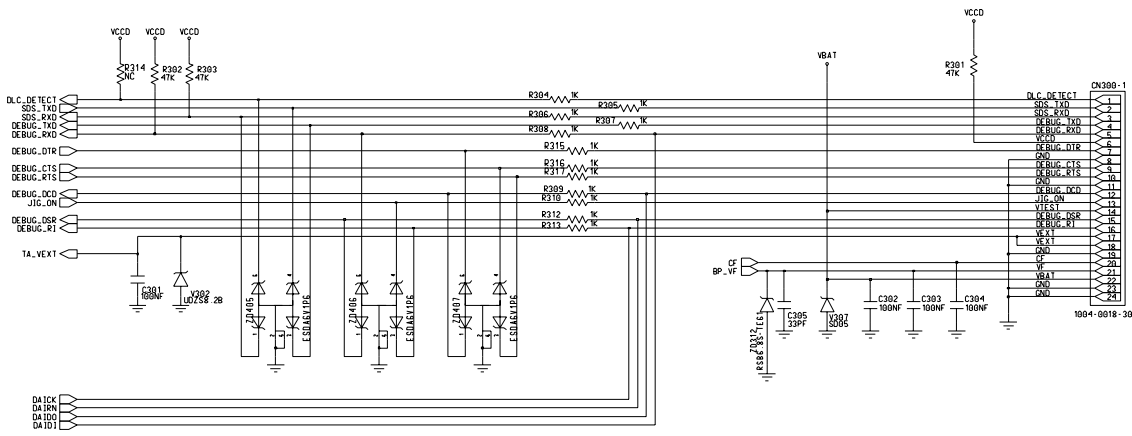

I/F CONNECTOR

Engineer	COMPANY NAME	
Drawn By	Address	
RDY CHK	TITLE:	Size
DOC CTRLR CHK	SGH-E300	
RFU ENDR CHK		

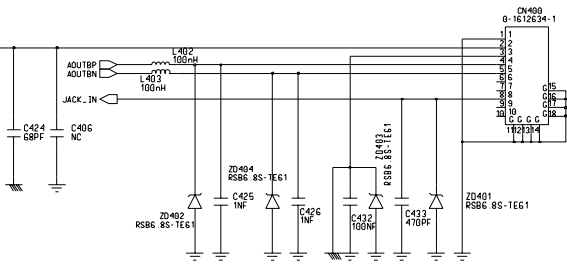
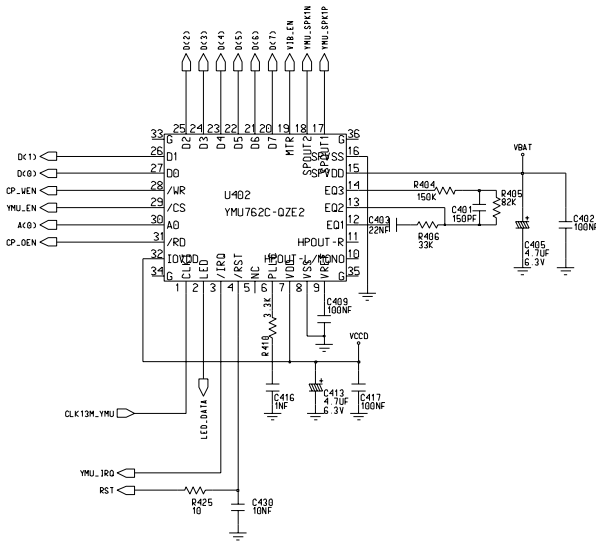
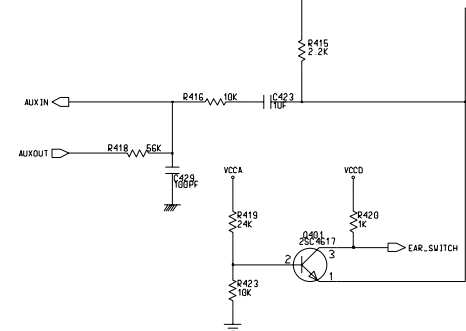
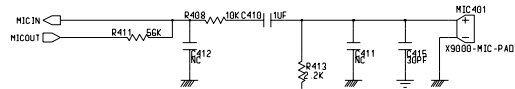
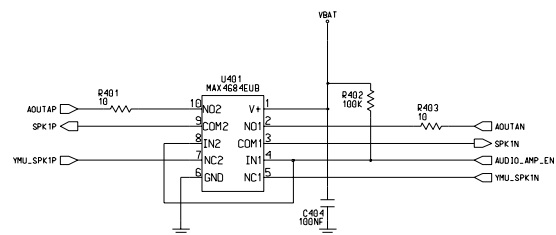

AUDIO

Enginner	COMPANY NAME
Drawn By	Address
REV CHK	TITLE:
IDOC CTRL CHK	SGH-E300
REV ENDR CHK	Sheet 4 of 10

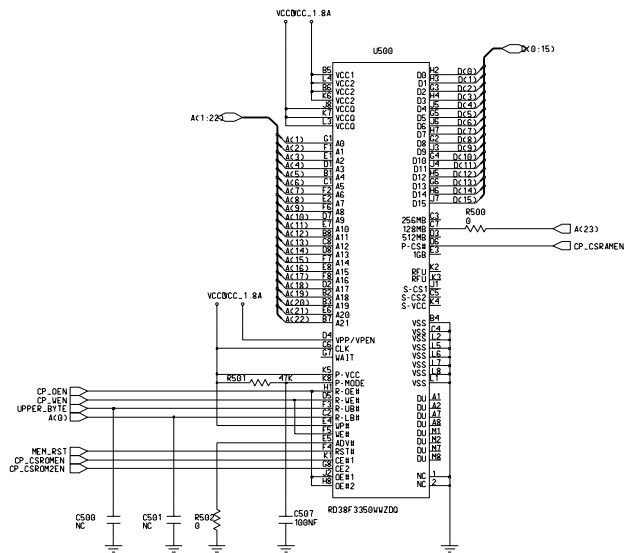

MEMORY

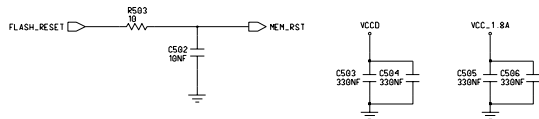

Enginner	SAMSUNG	
Drawn by	Address	
RDU CHK	TITLE:	Size
IDOC CTRL CHK	SGH-E300	
RDU ENDR CHK	Drawing Number	
DA CHK	7	Sheet 5 of 10
user8	Date changed 2004.09.01	1mg changed 5:15:20 pm

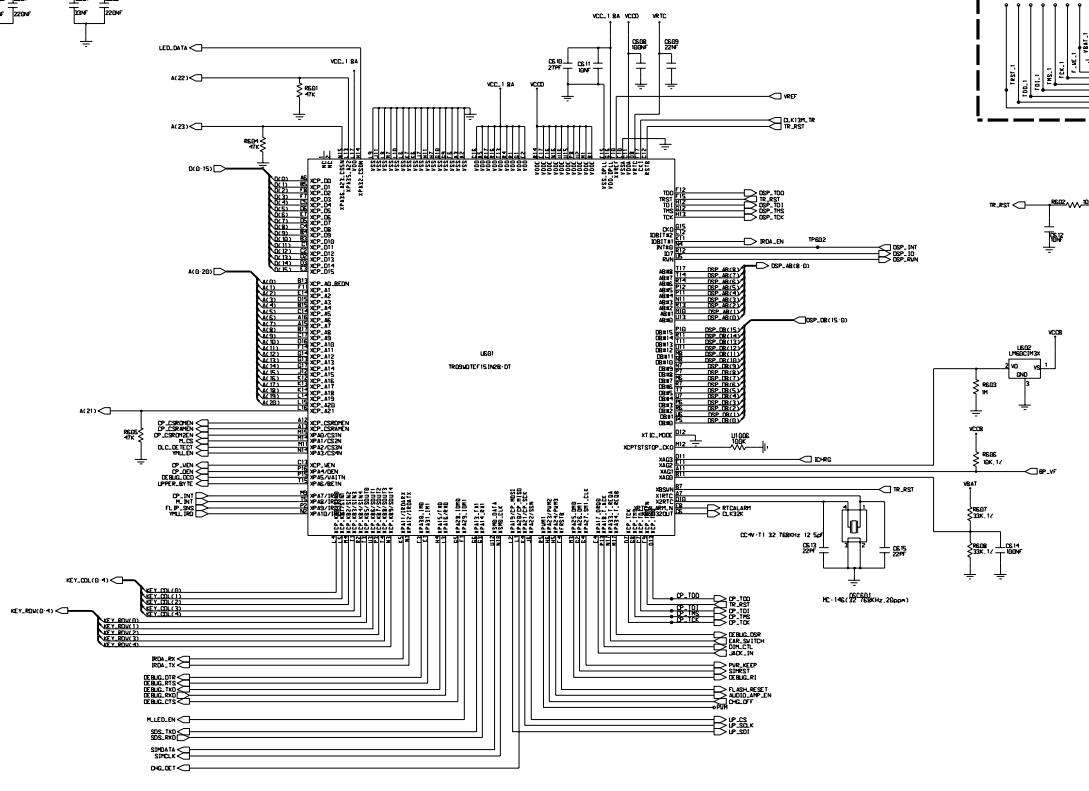
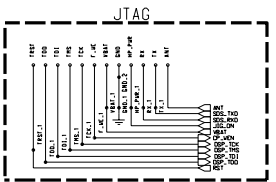
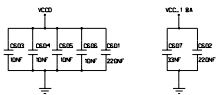

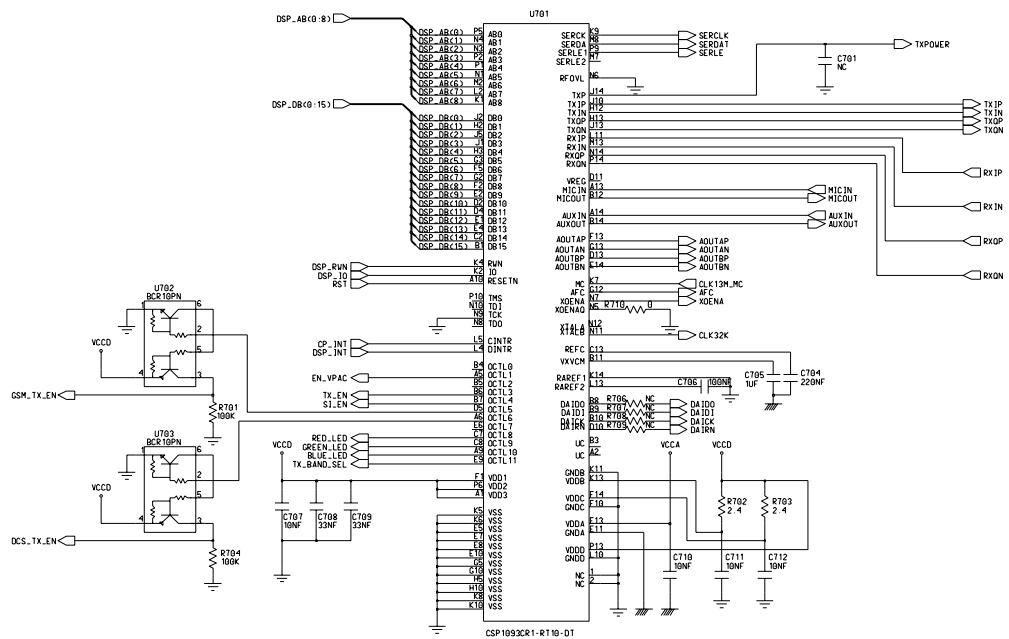

CSP1093

Engineer	COMPANY NAME	
Drawn By	Address	
REV CHK	TITLE:	Size
IDOC CTRL CHK	SCH-E-300	
REV ENDR CHK		
Changed By	Date Changed	DA CHK
user8	2004.09.01	7
	1 mg. changed	REV
	5/16/03 pat	124
		Drawing Number
		Sheet 7 of 10

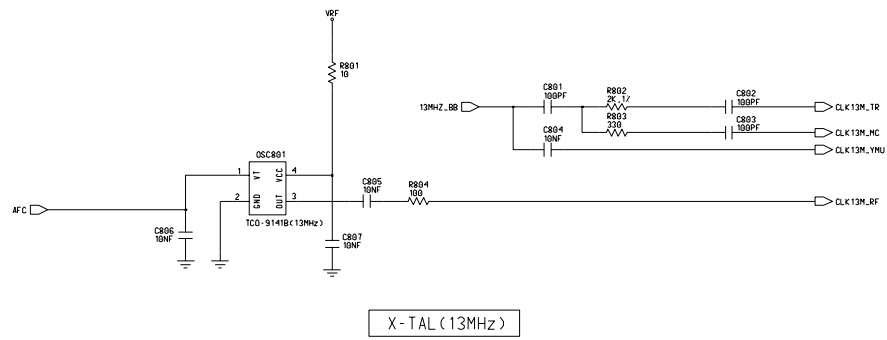
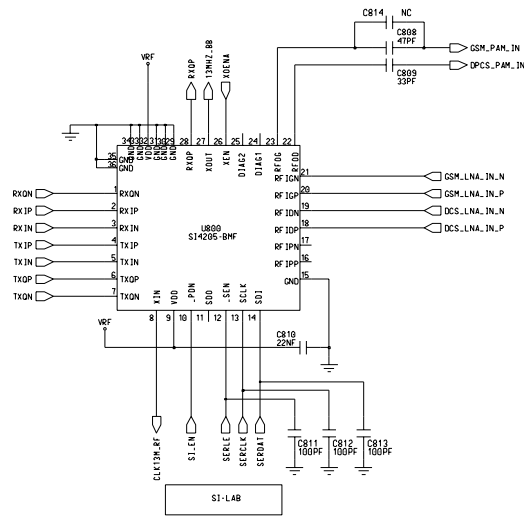

X-TAL (13MHz)

Enginner	COMPANY NAME	
Drawn By	Address	
REV CHK	TITLE:	Size
IDOC CTRL CHK	SGH-E 300	6A
REV ENDR CHK		

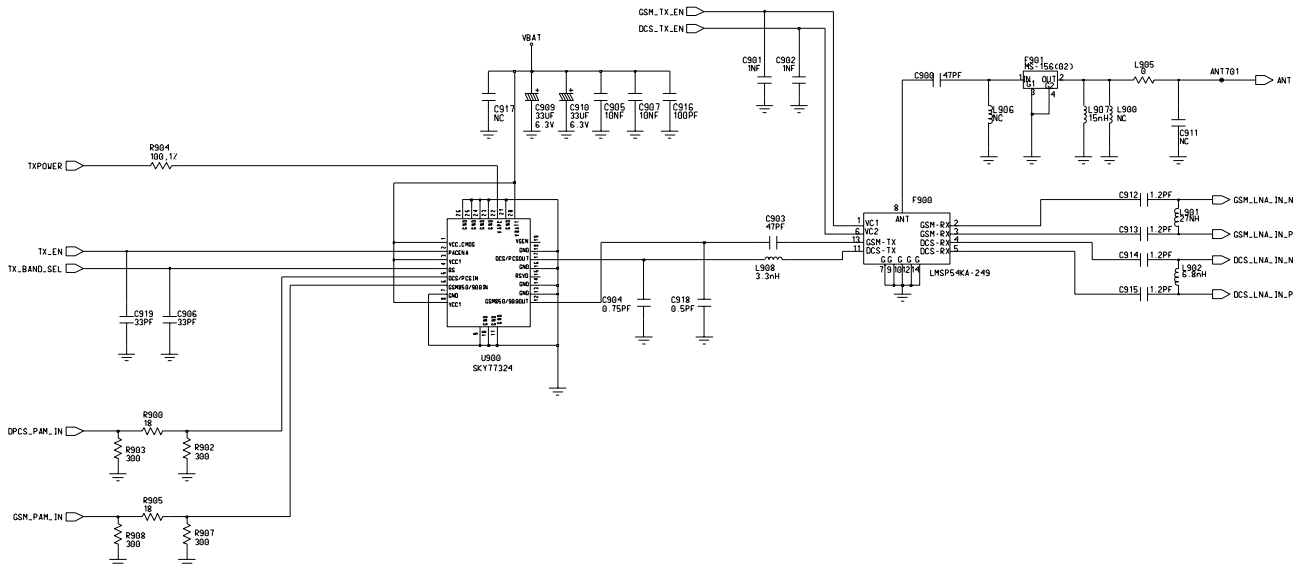

TRANSMITTER & RECEIVER

Engineer	COMPANY NAME	
Drawn By	Address	
RDY CHK	TITLE:	Size
IDOC CTRL CHK	SGH-E300	
RDY ENDR CHK	Sheet 9 of 10	

