

9. Flow Chart of Troubleshooting

9-1. Power On

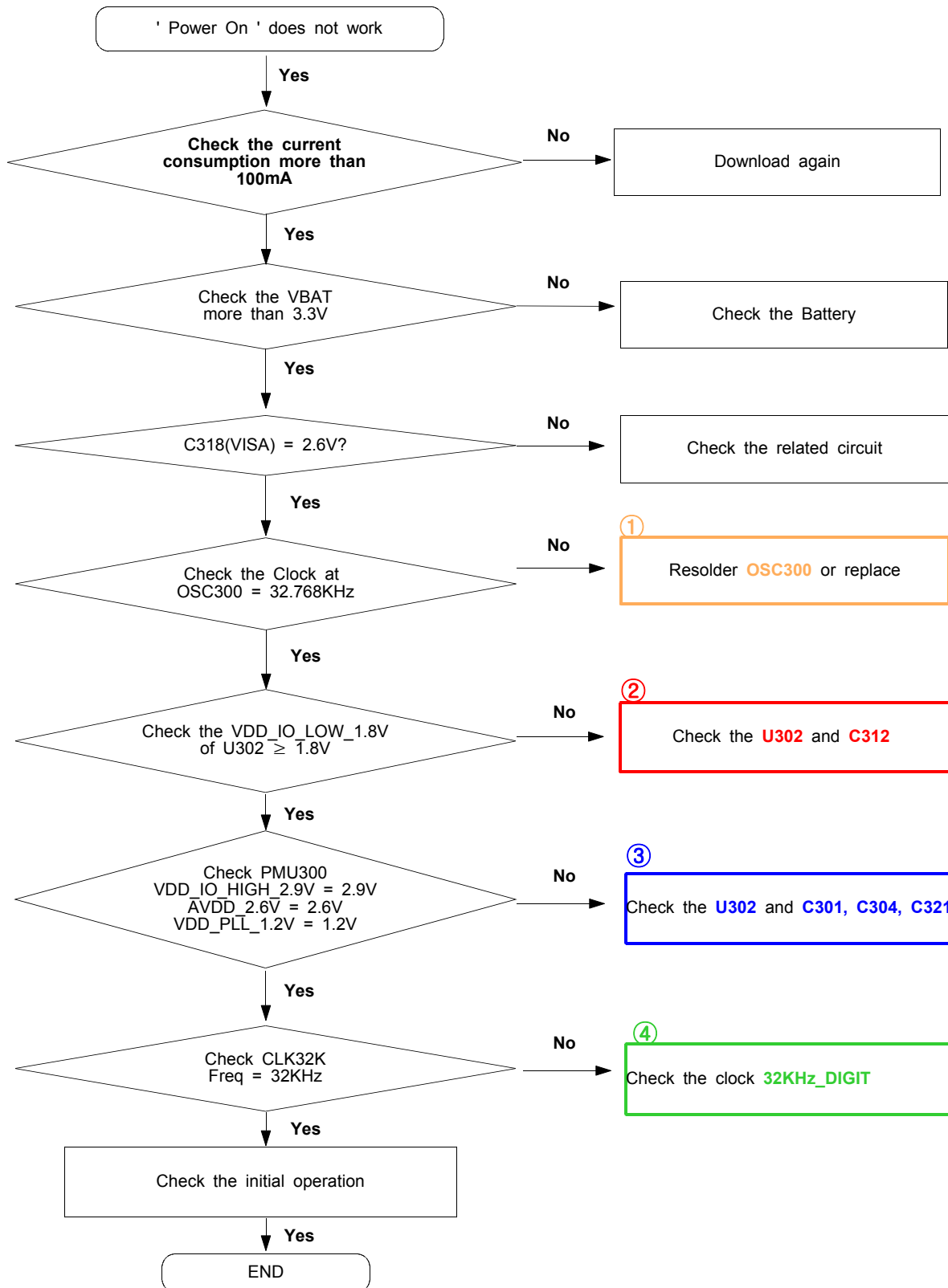

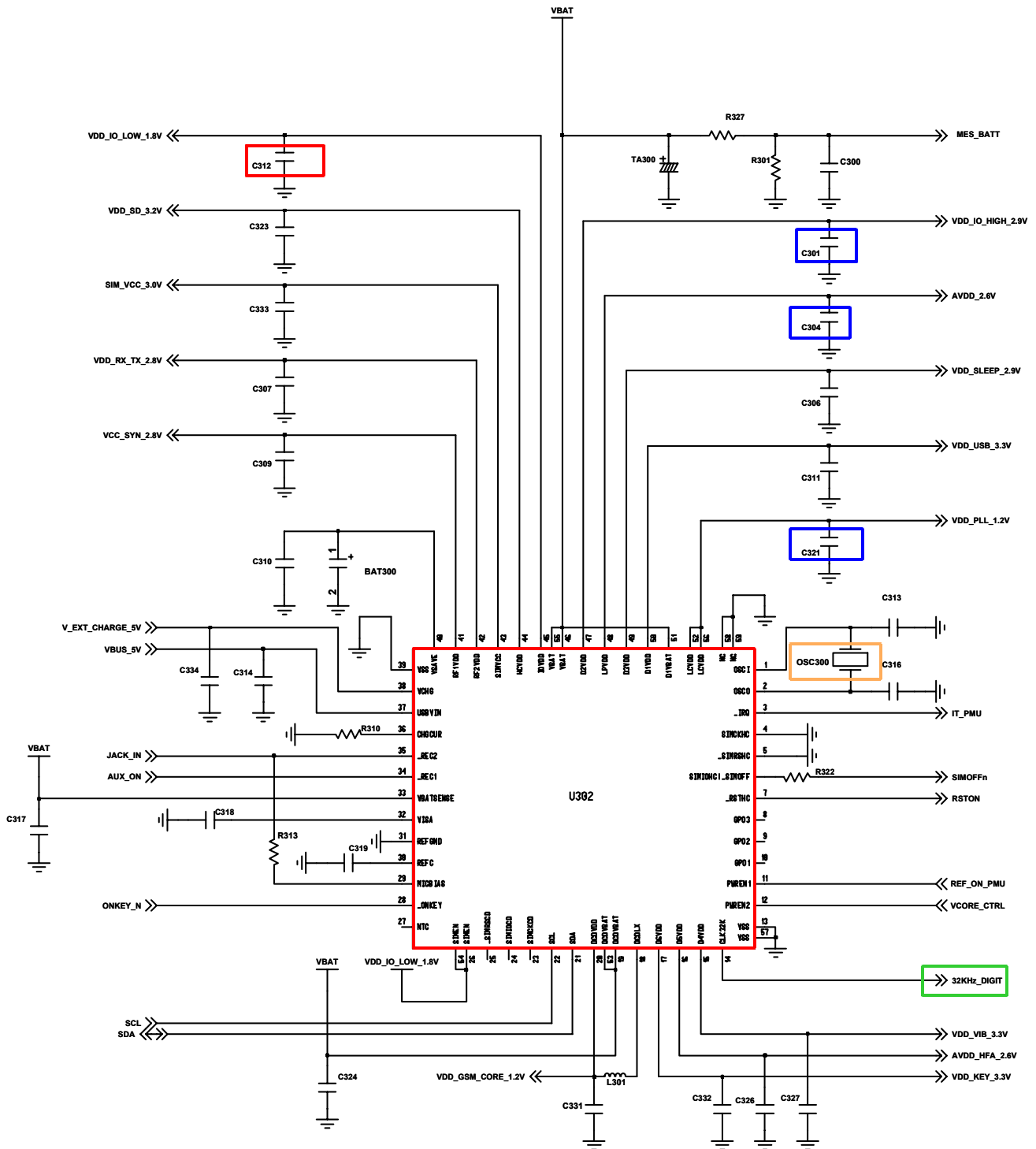

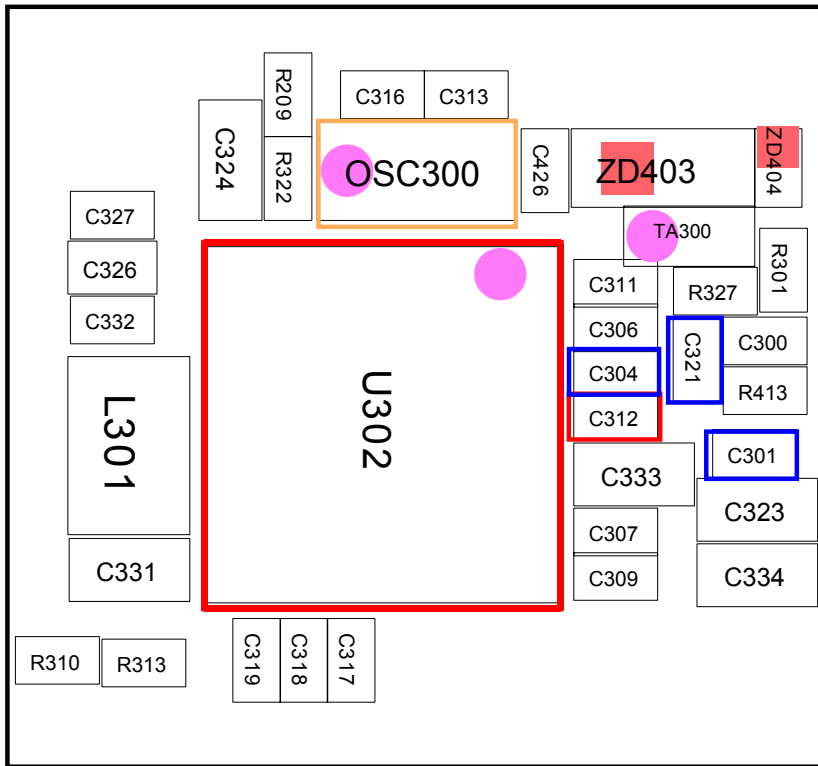

9-2. Initial

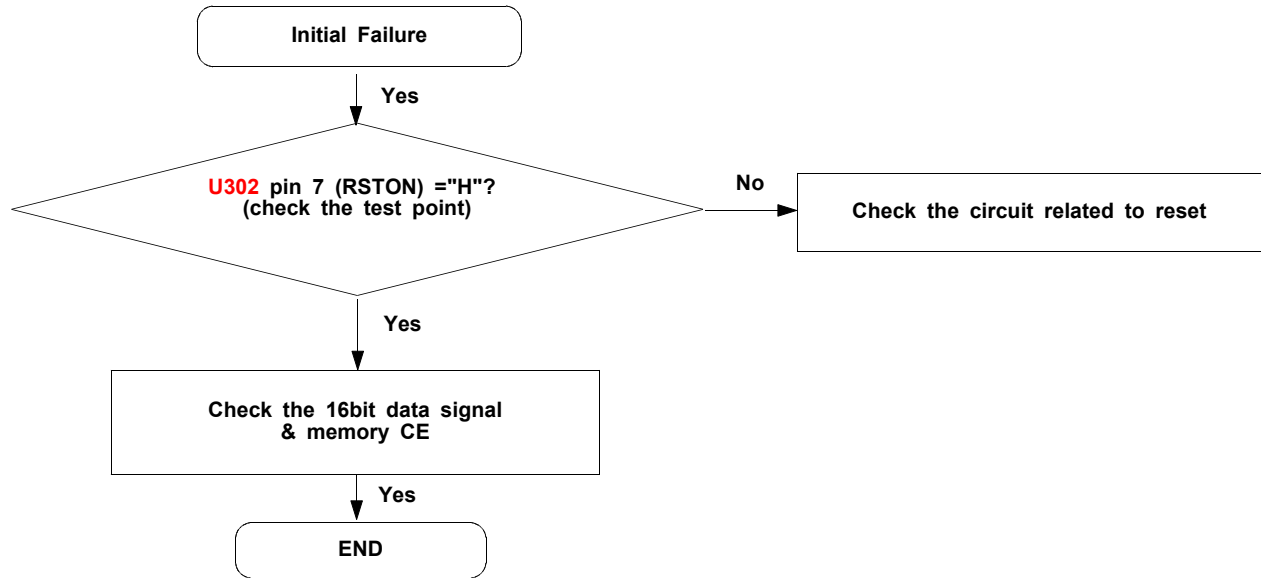

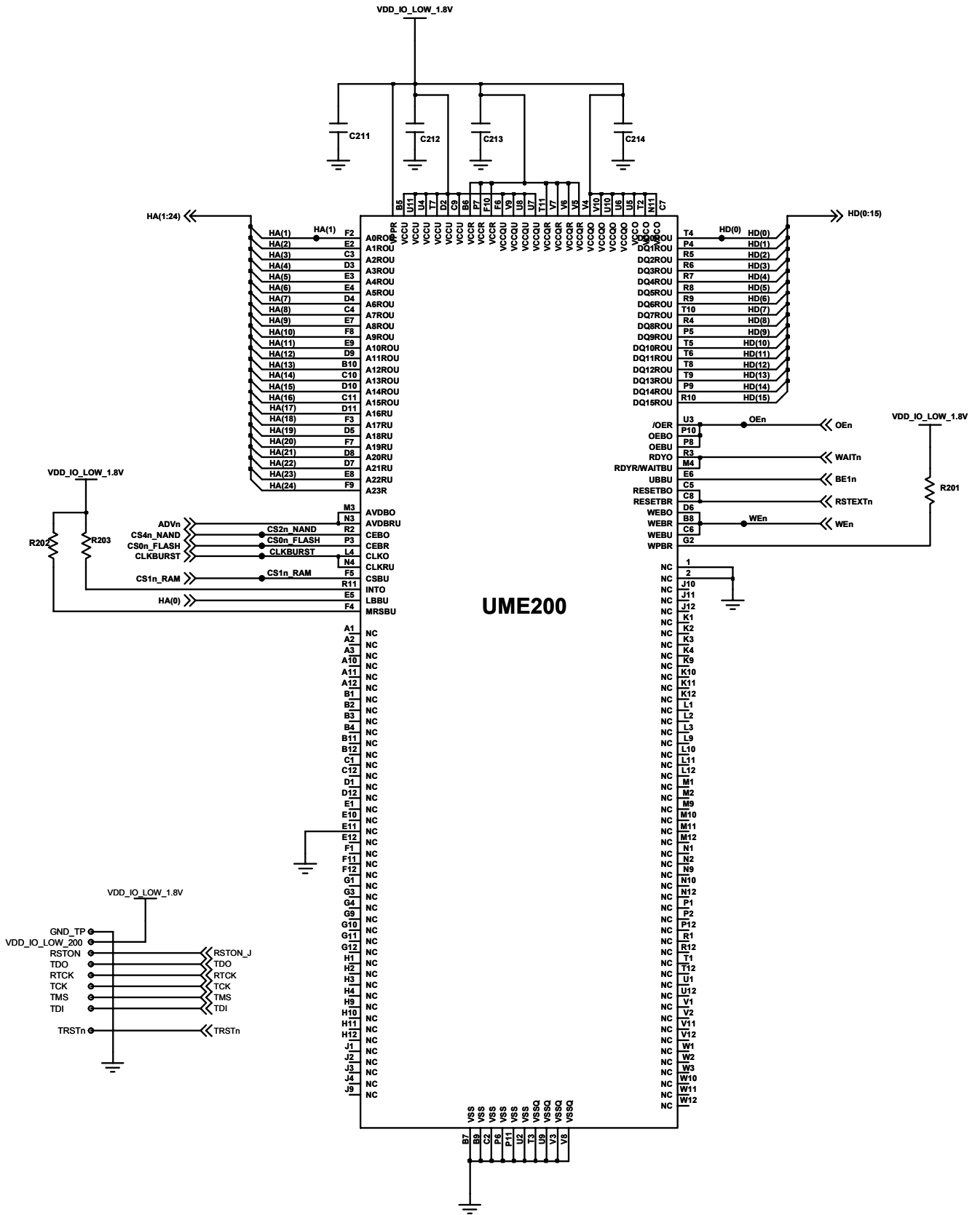

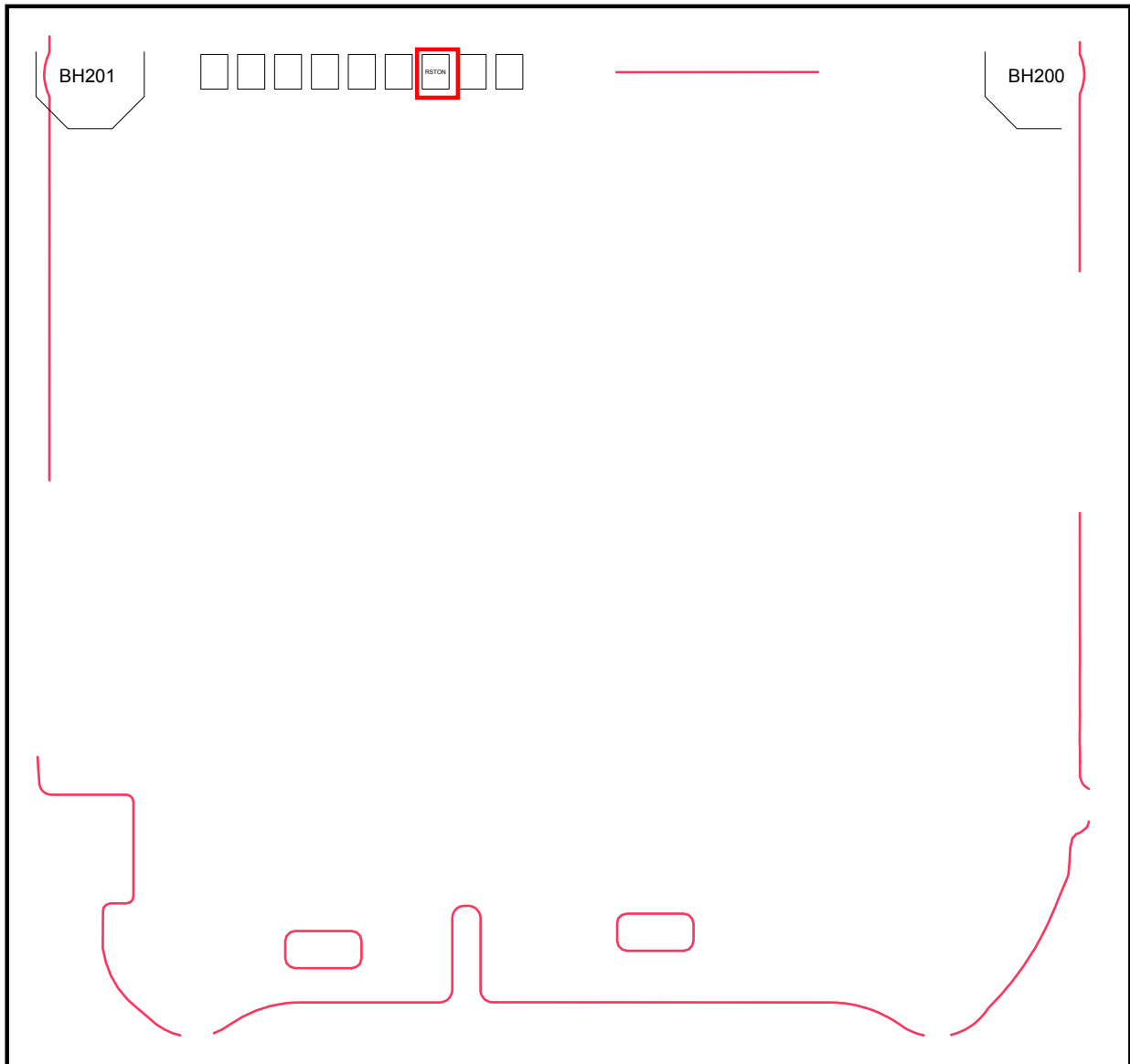
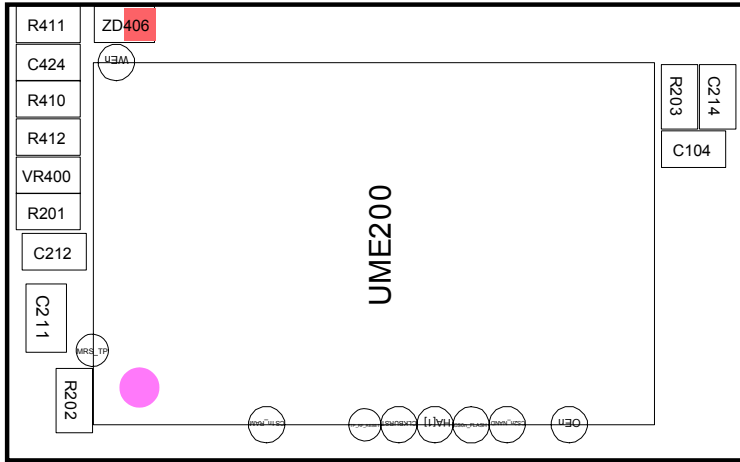

9-3. Charging Part

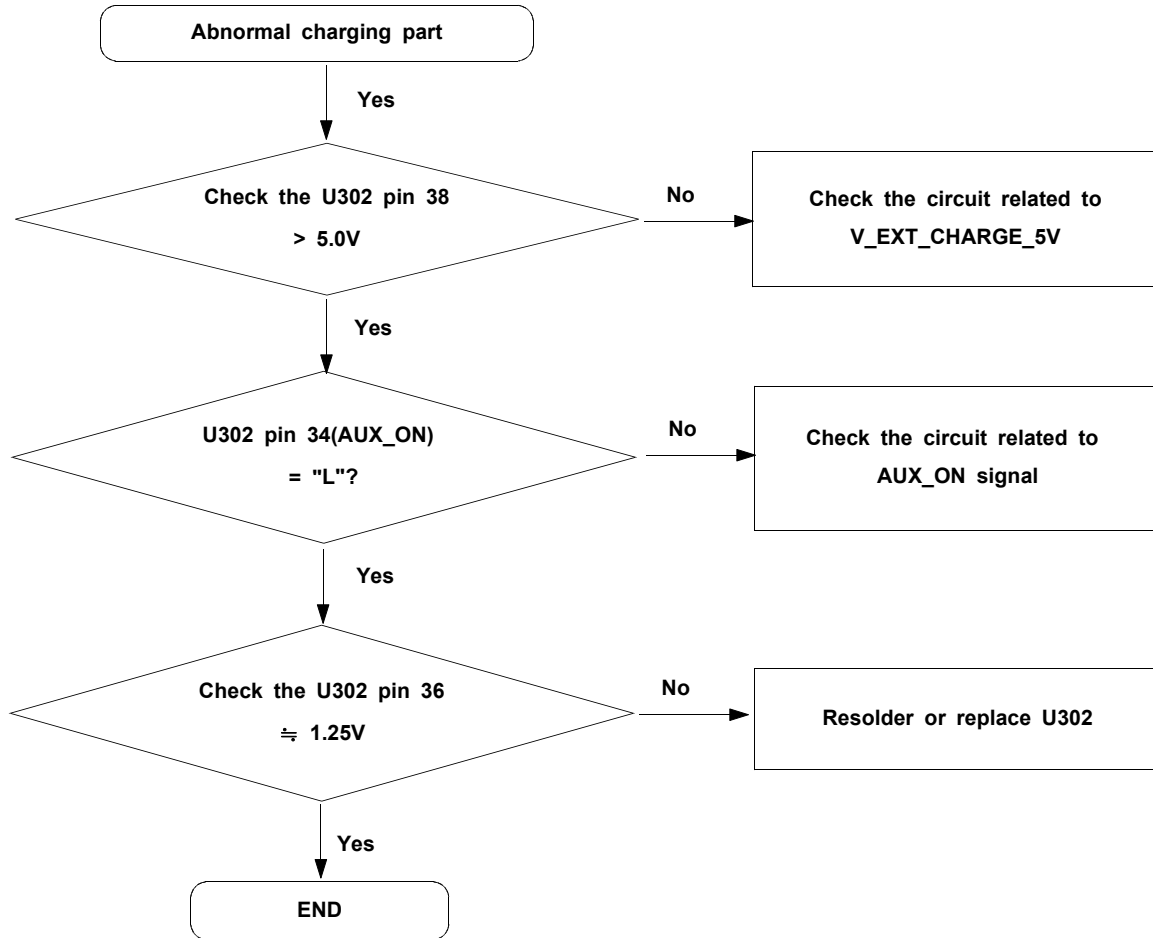

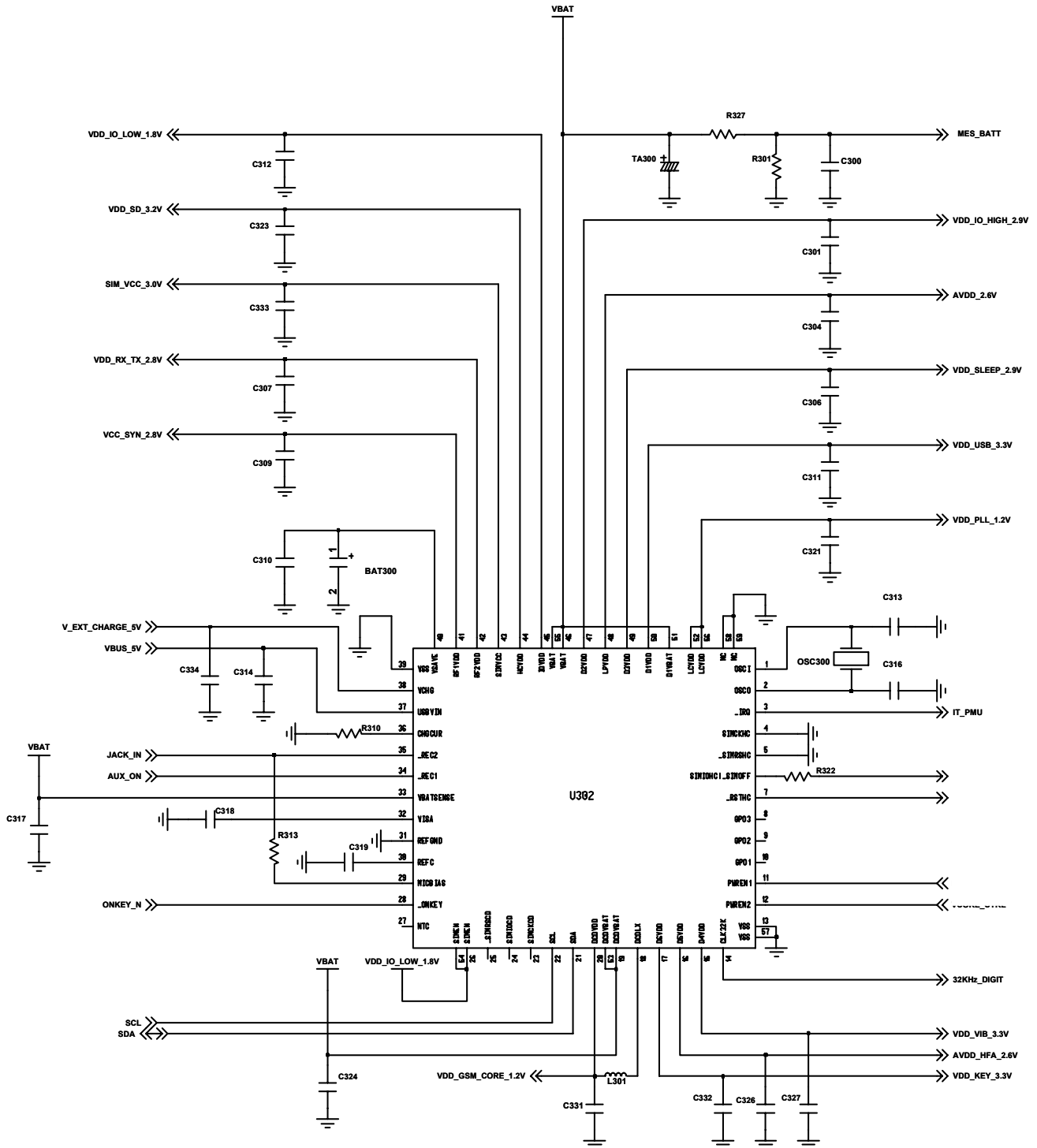

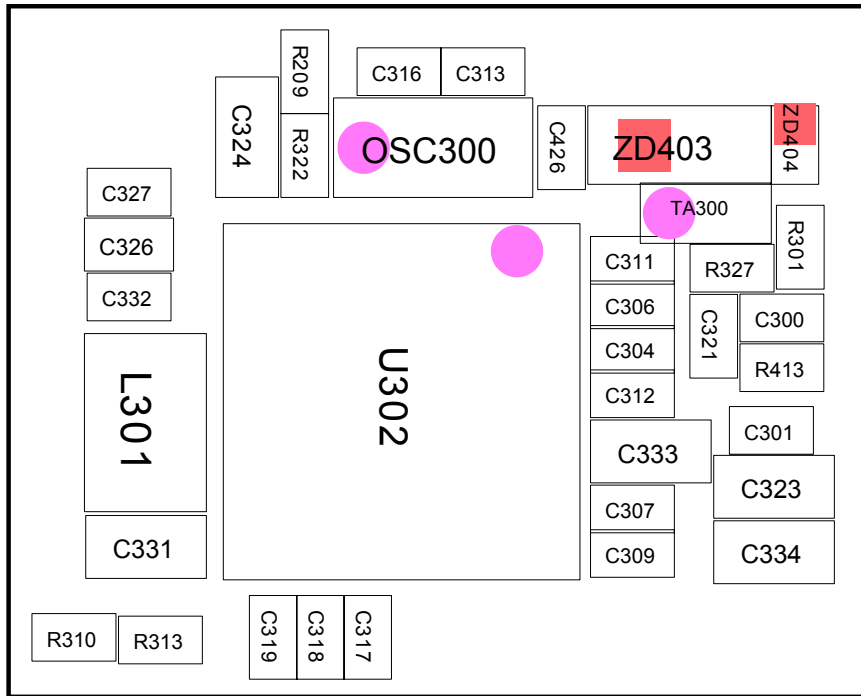

9-4. Sim Part

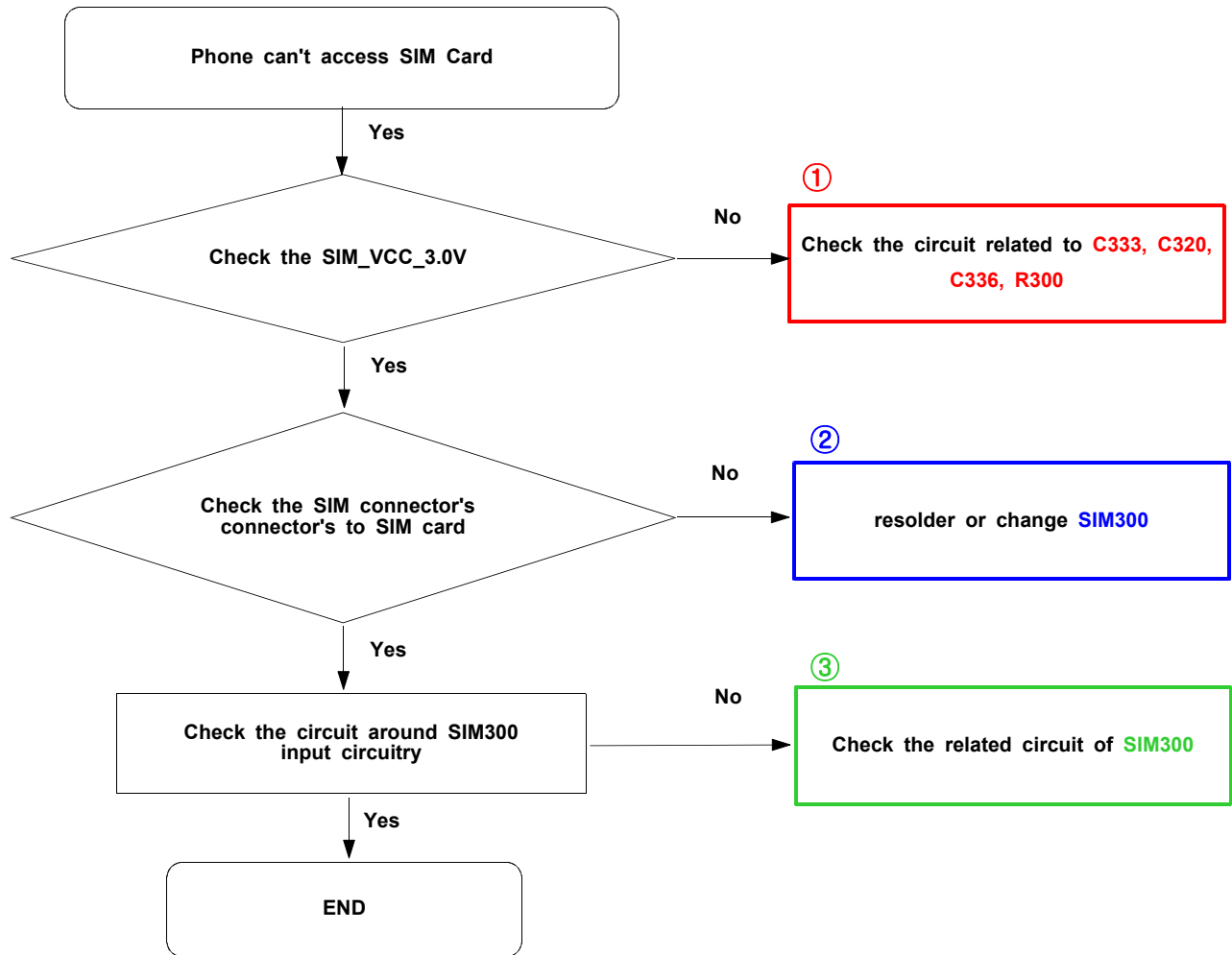

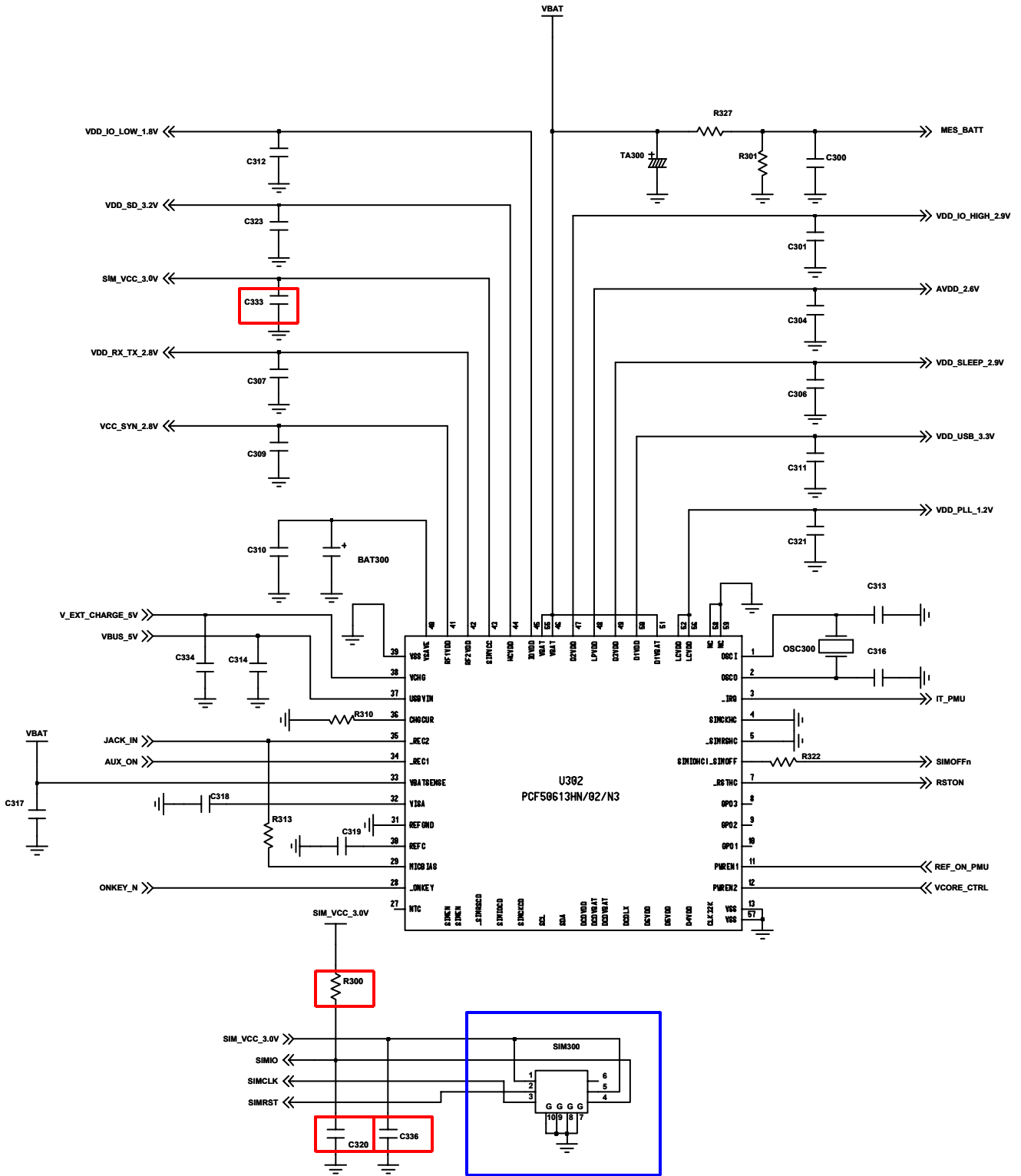

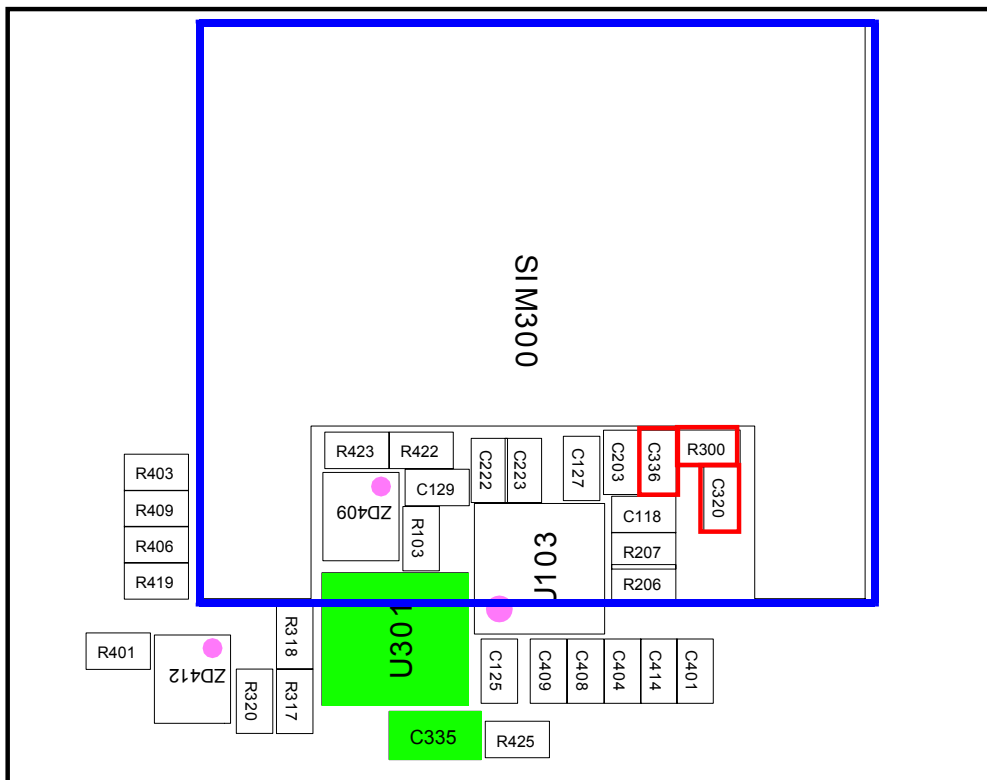
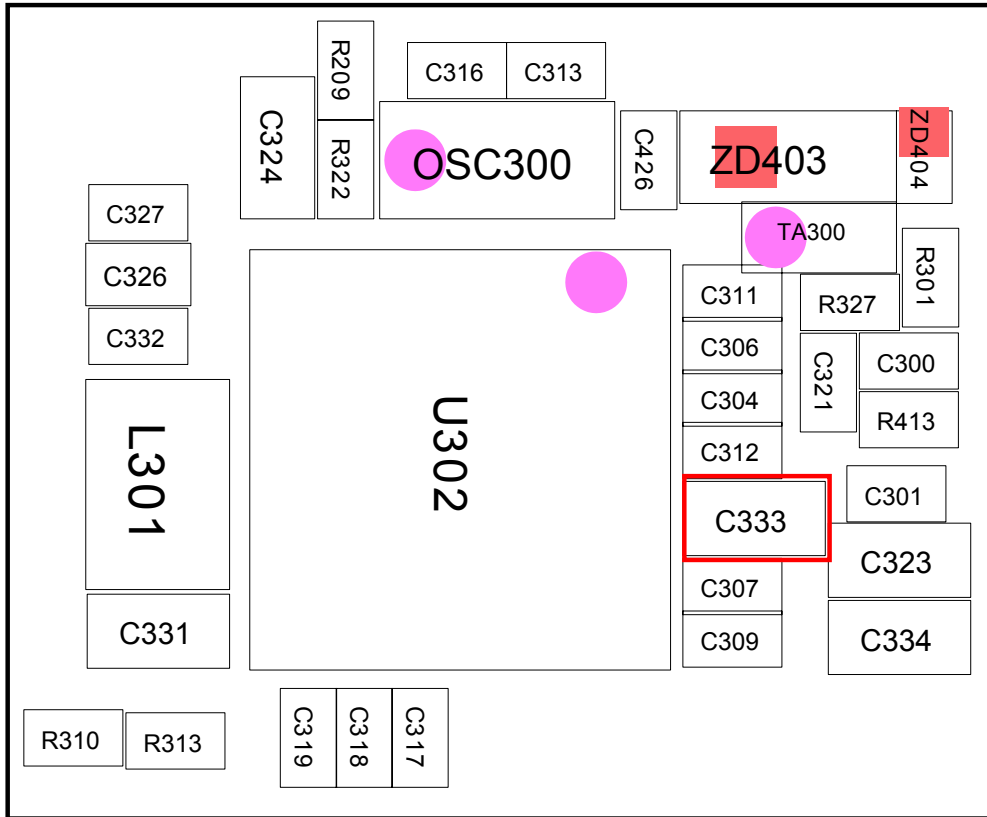

9-5. Microphone Part

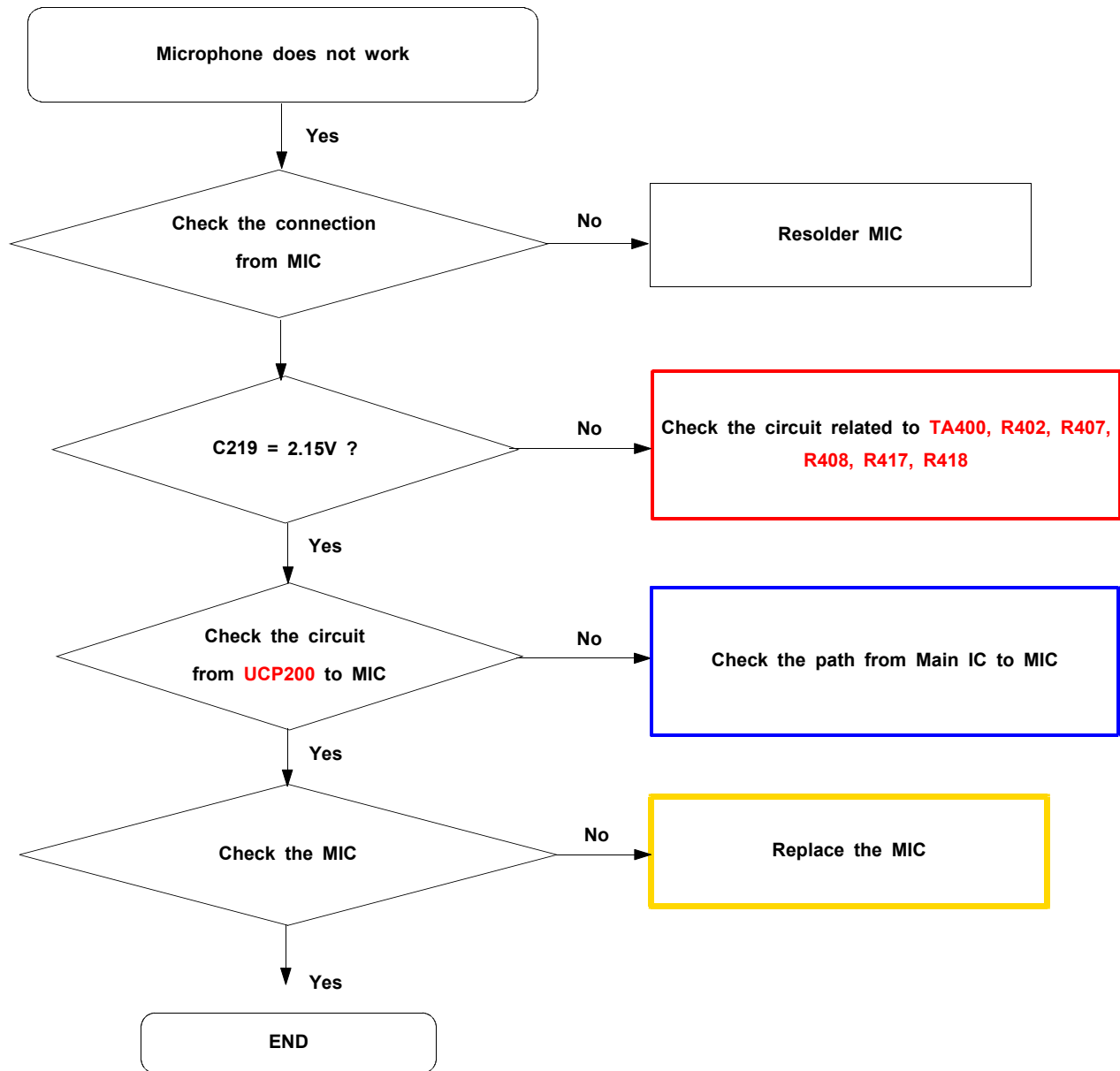

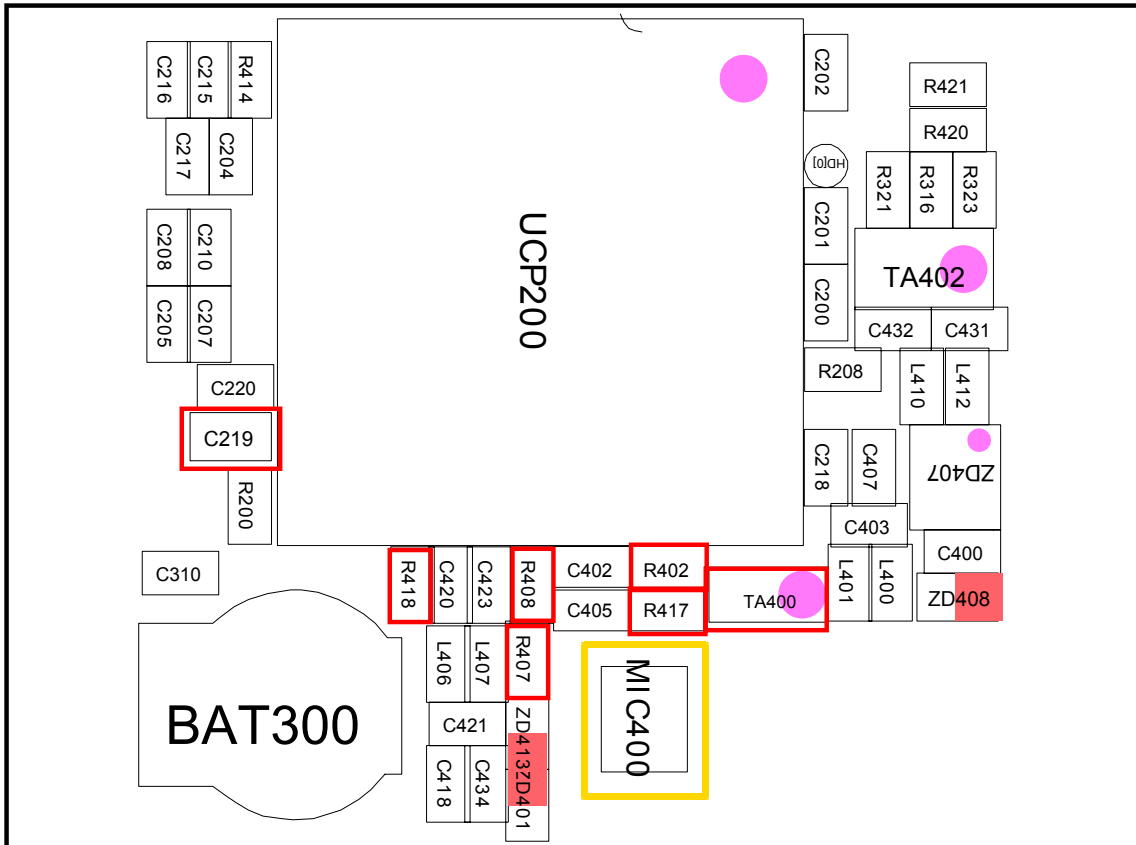
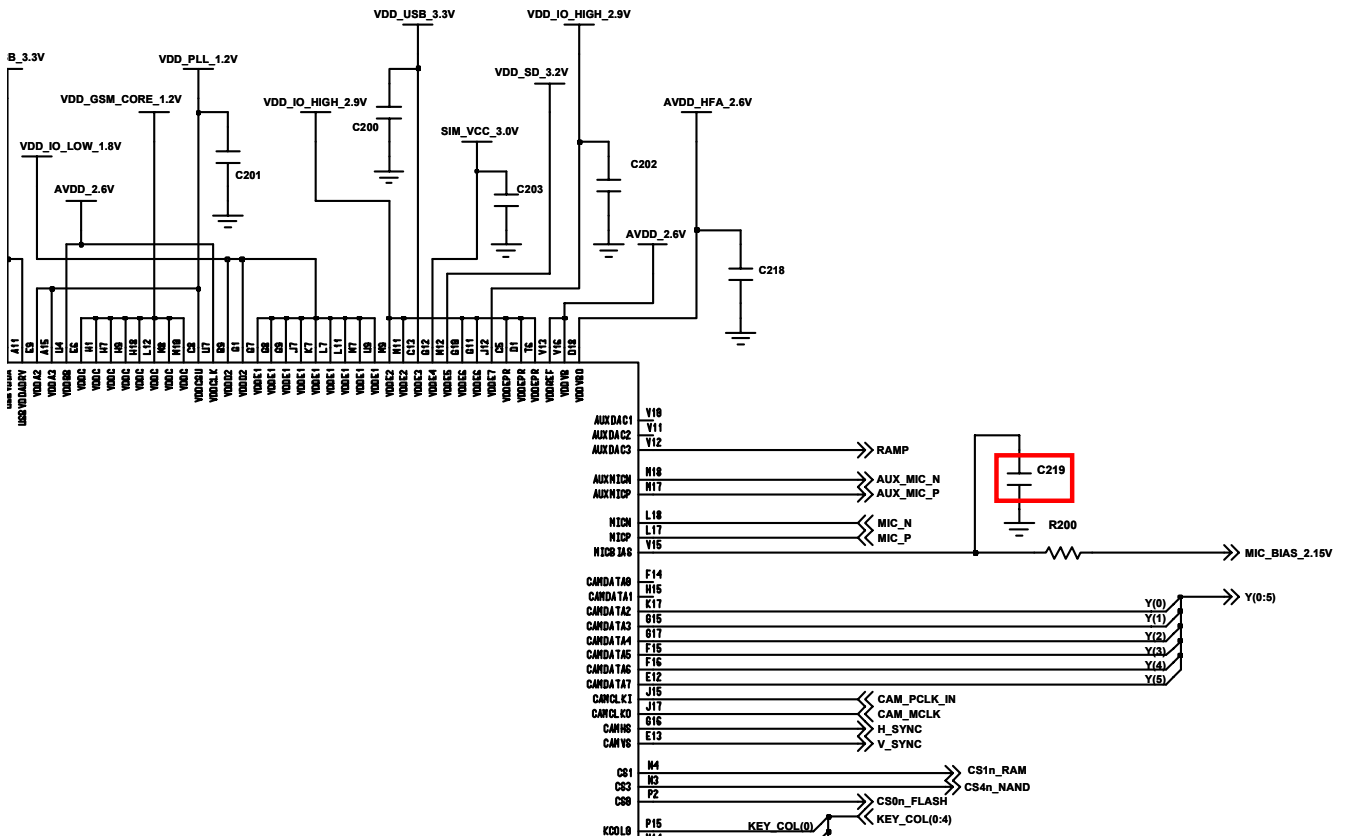

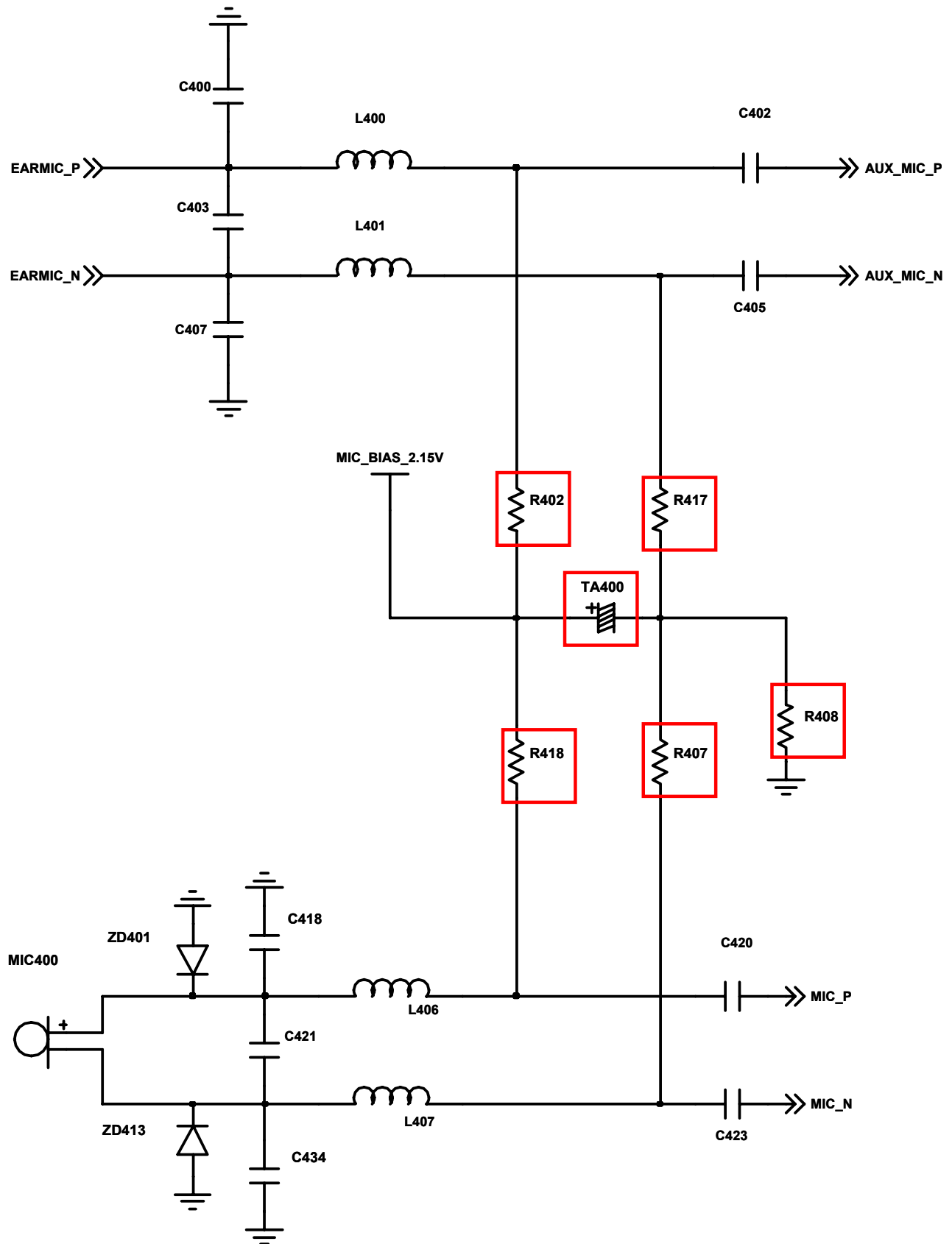

9-6. Speaker Part(Melody)

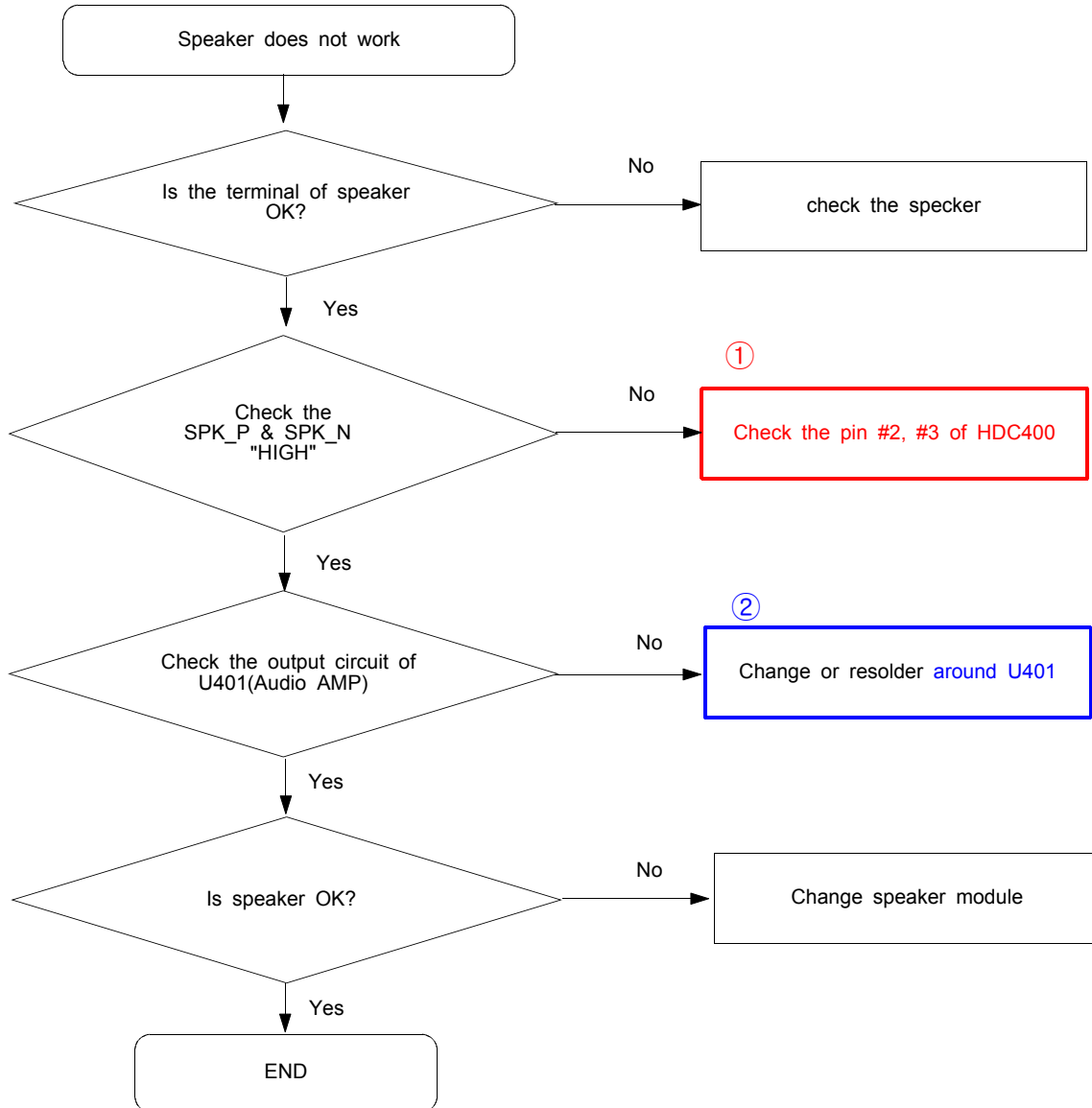

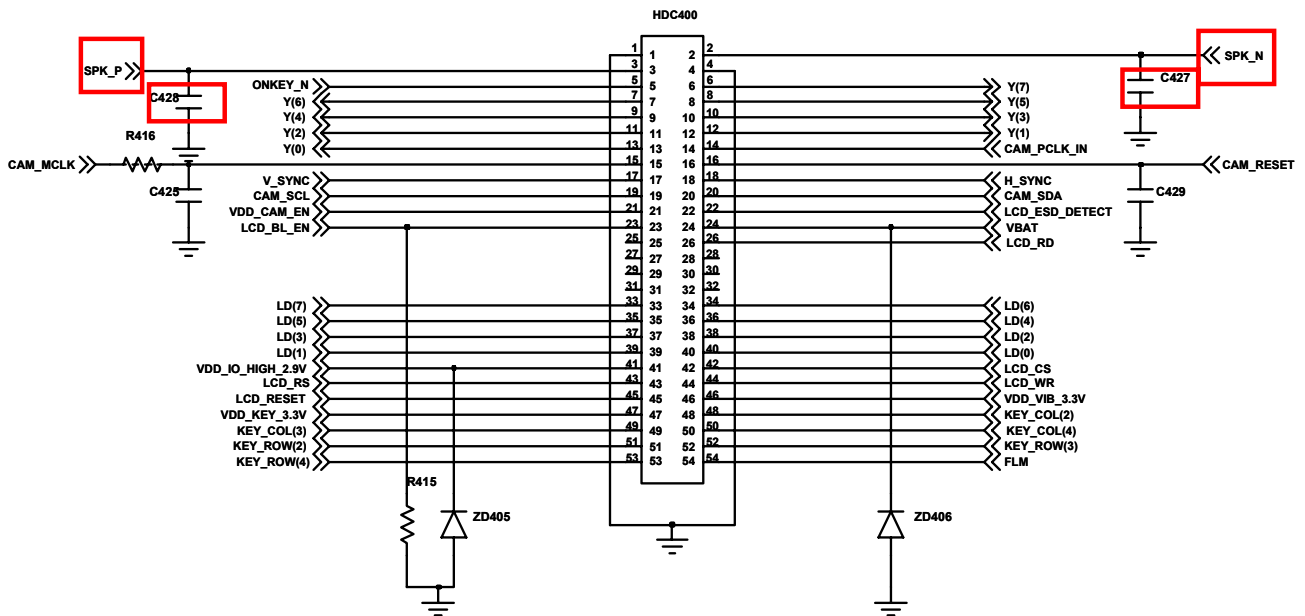
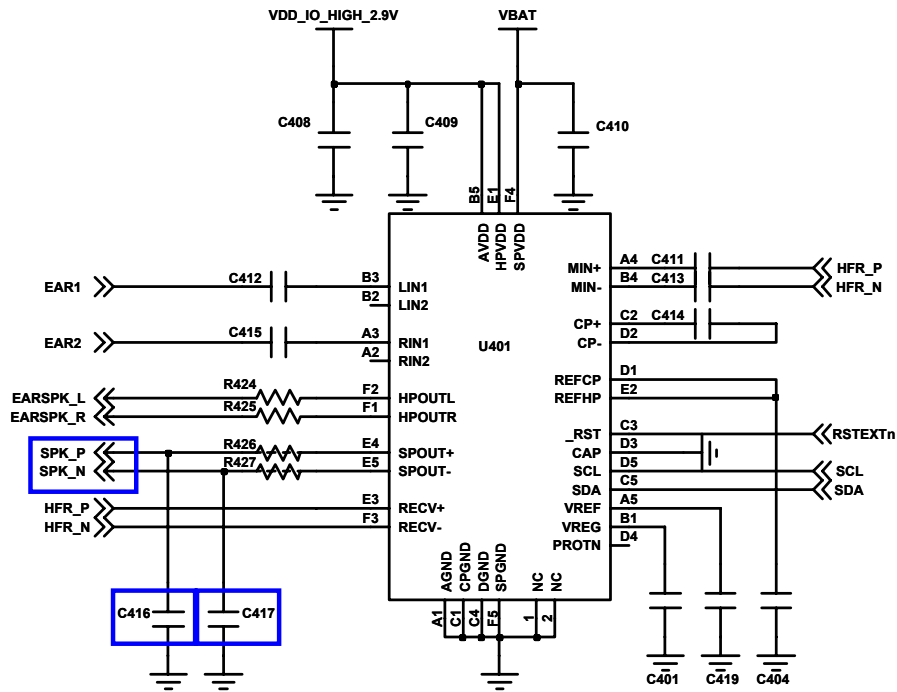

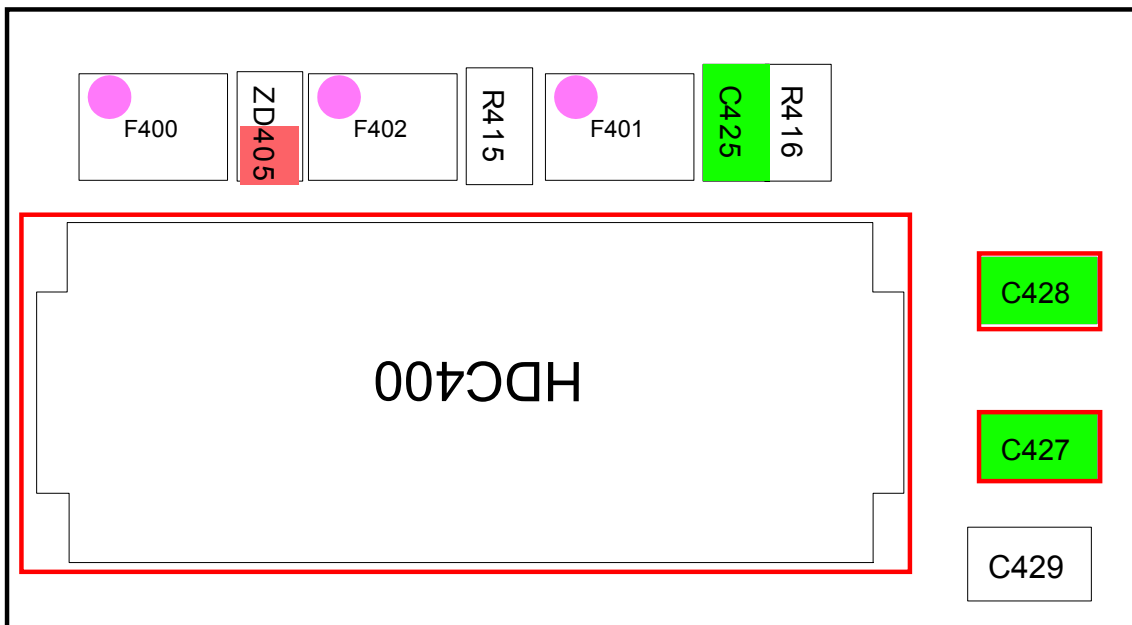
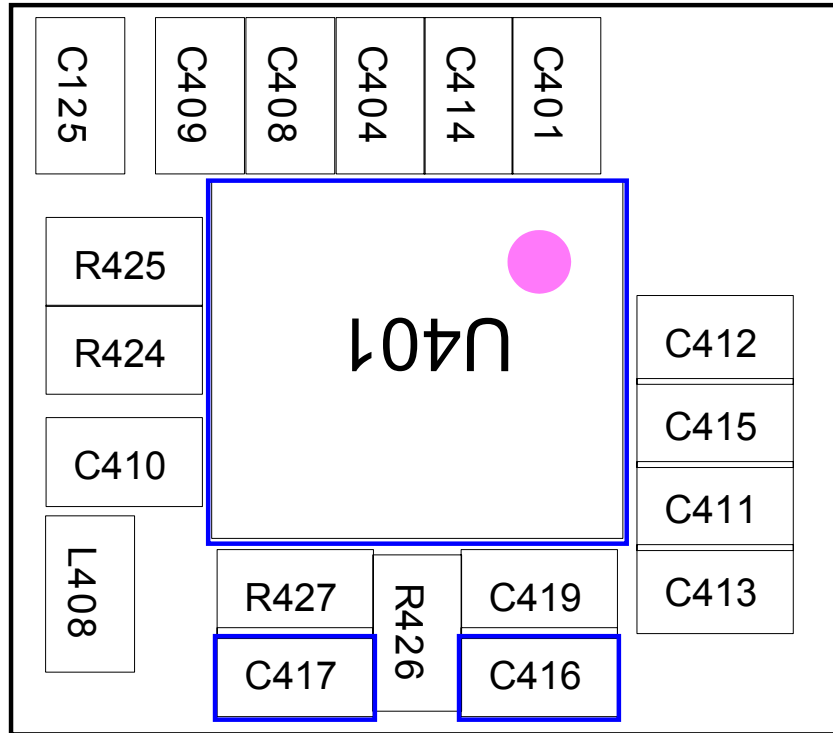

9-7. Key Data Input

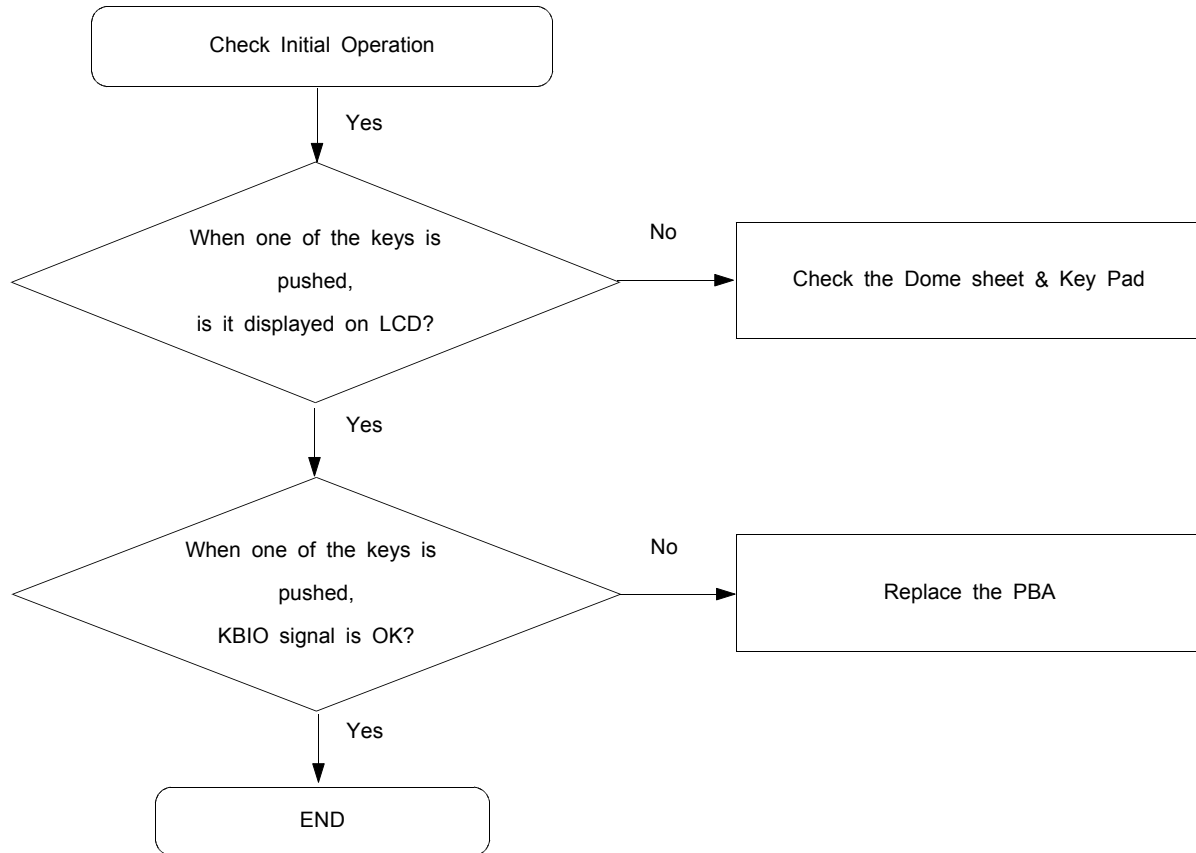

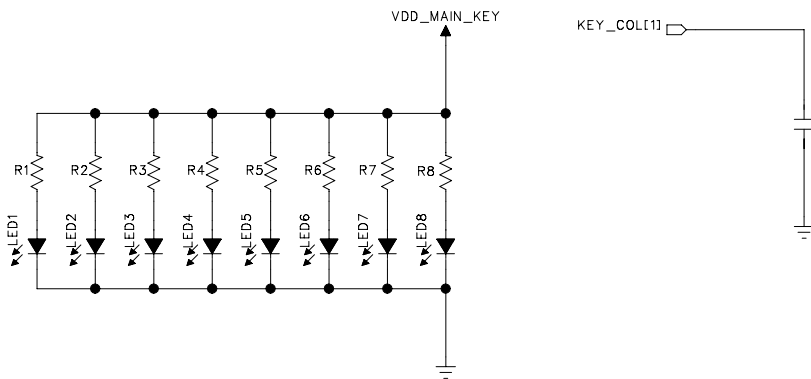
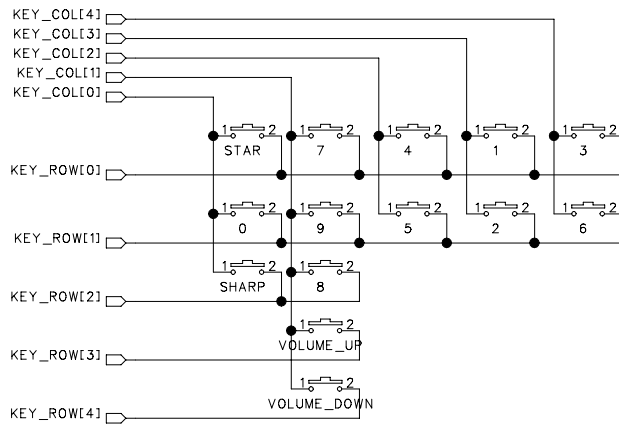
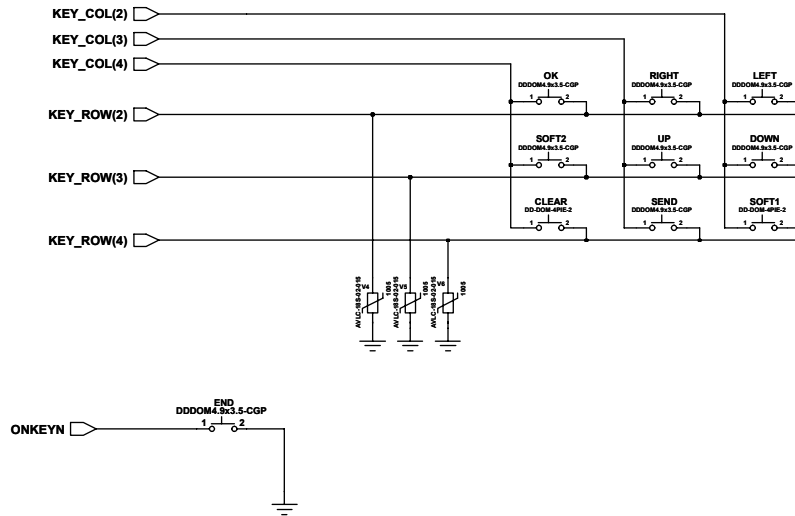

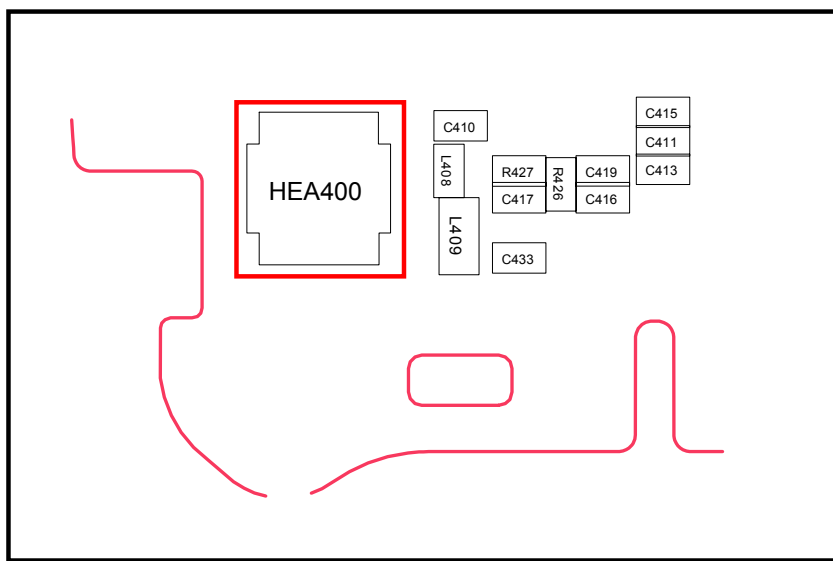
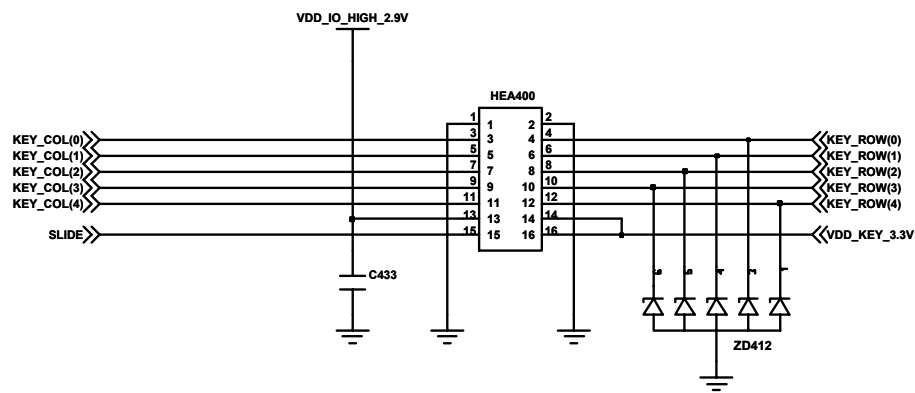
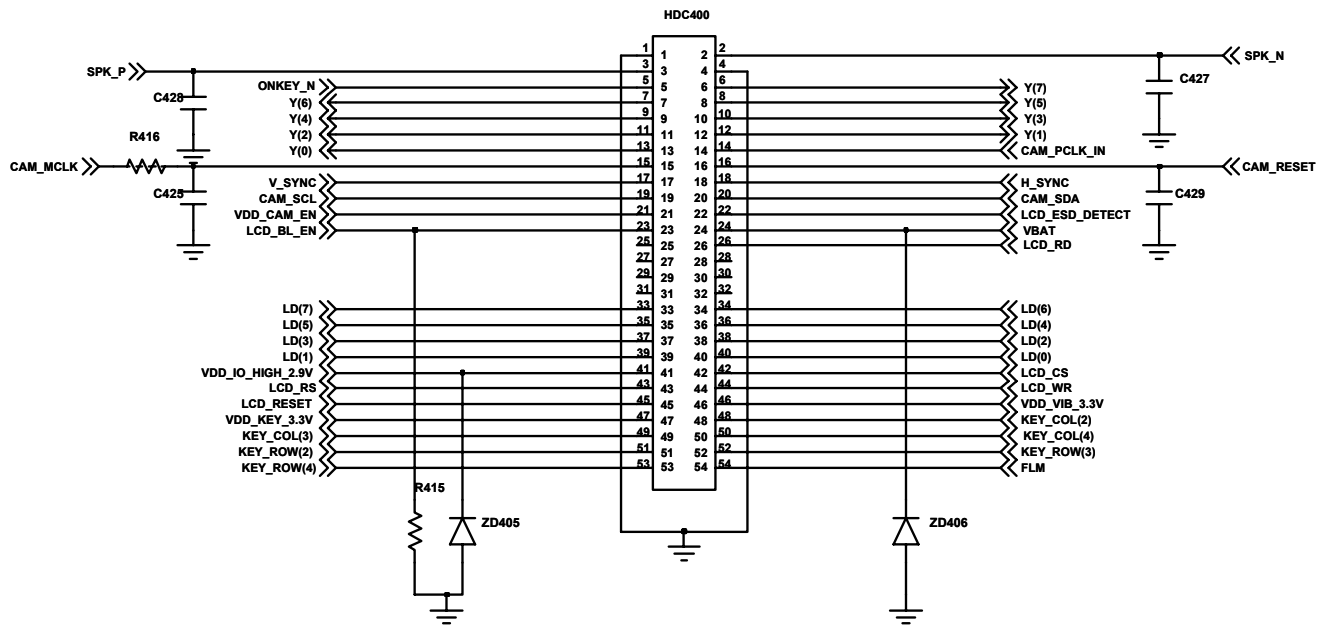

9-8. Camera part

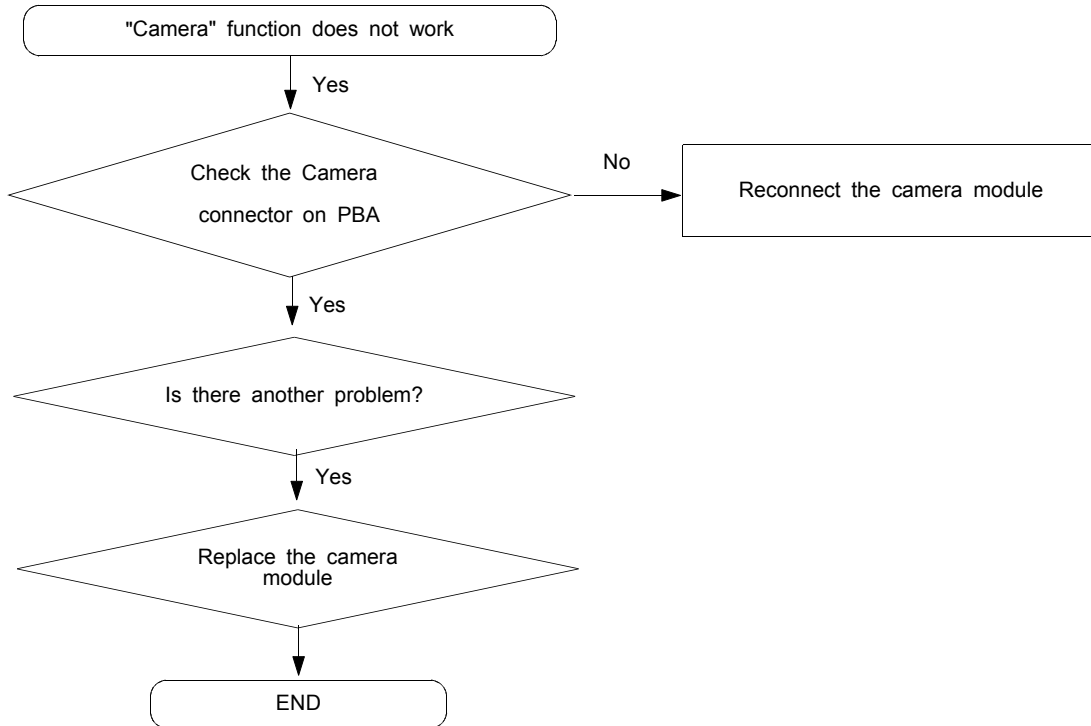

9-9. Radio part

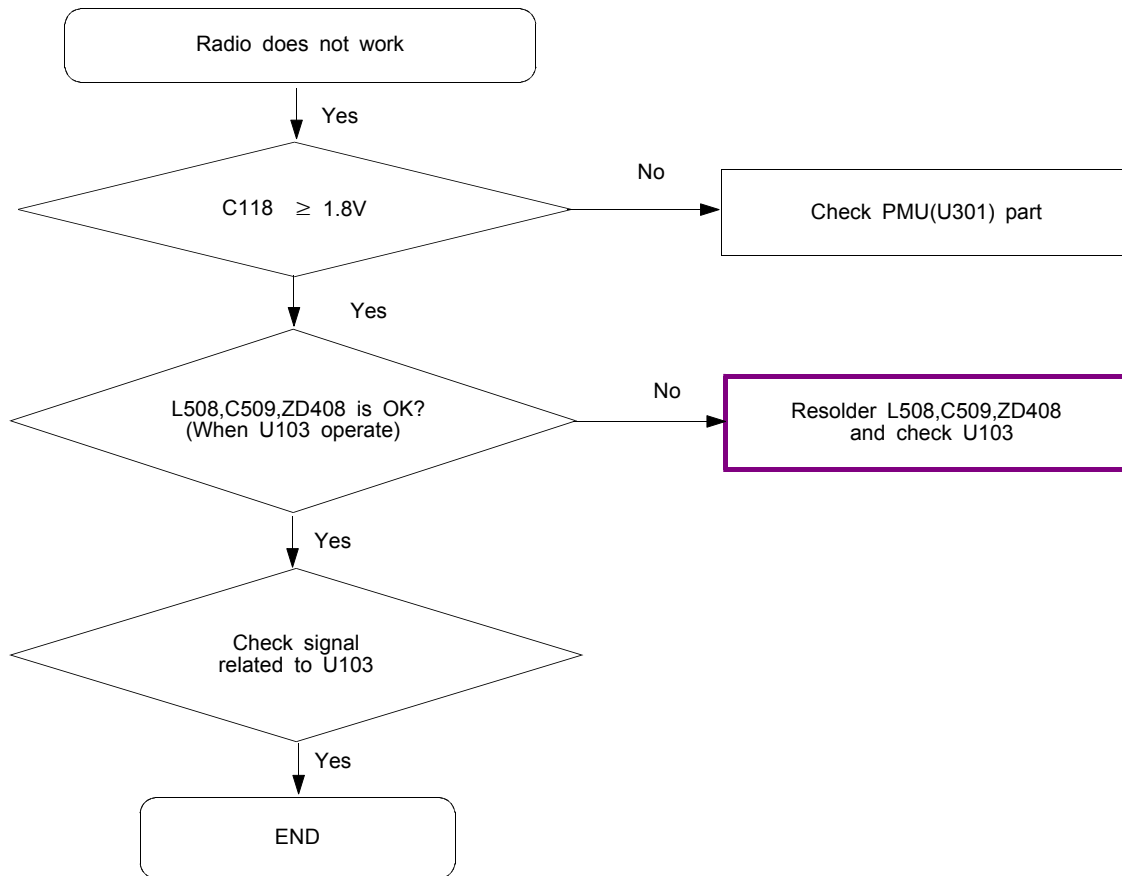

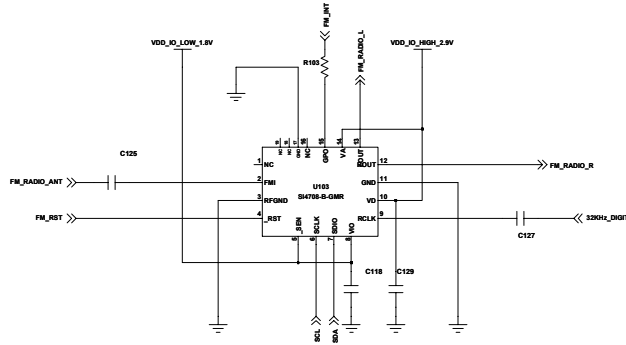

FM RADIO

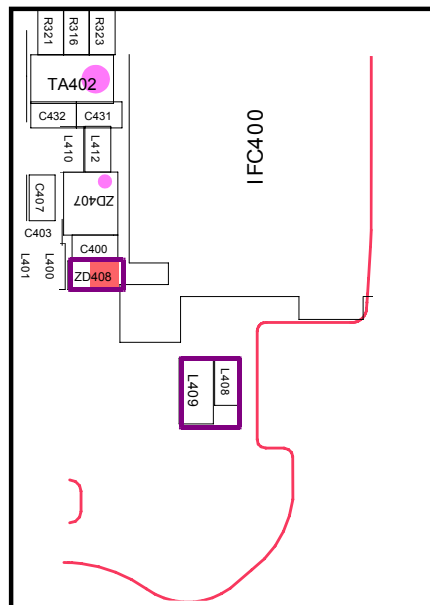
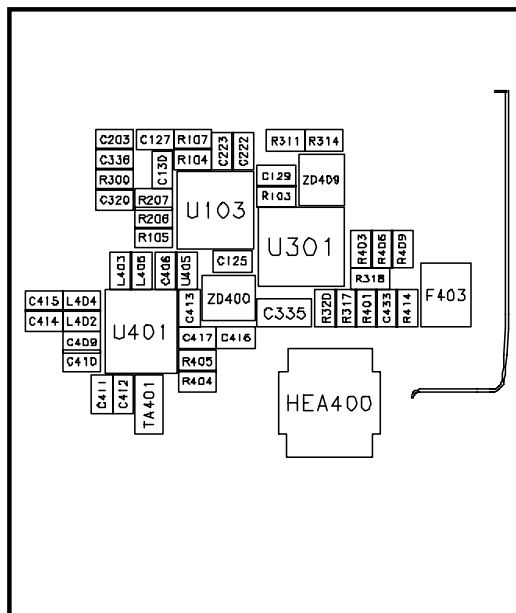
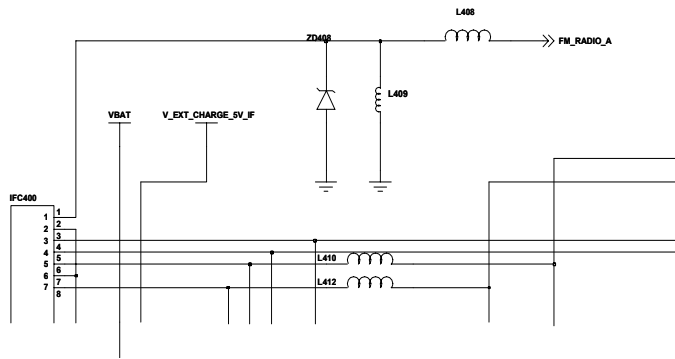

9-10. GSM900 Receiver

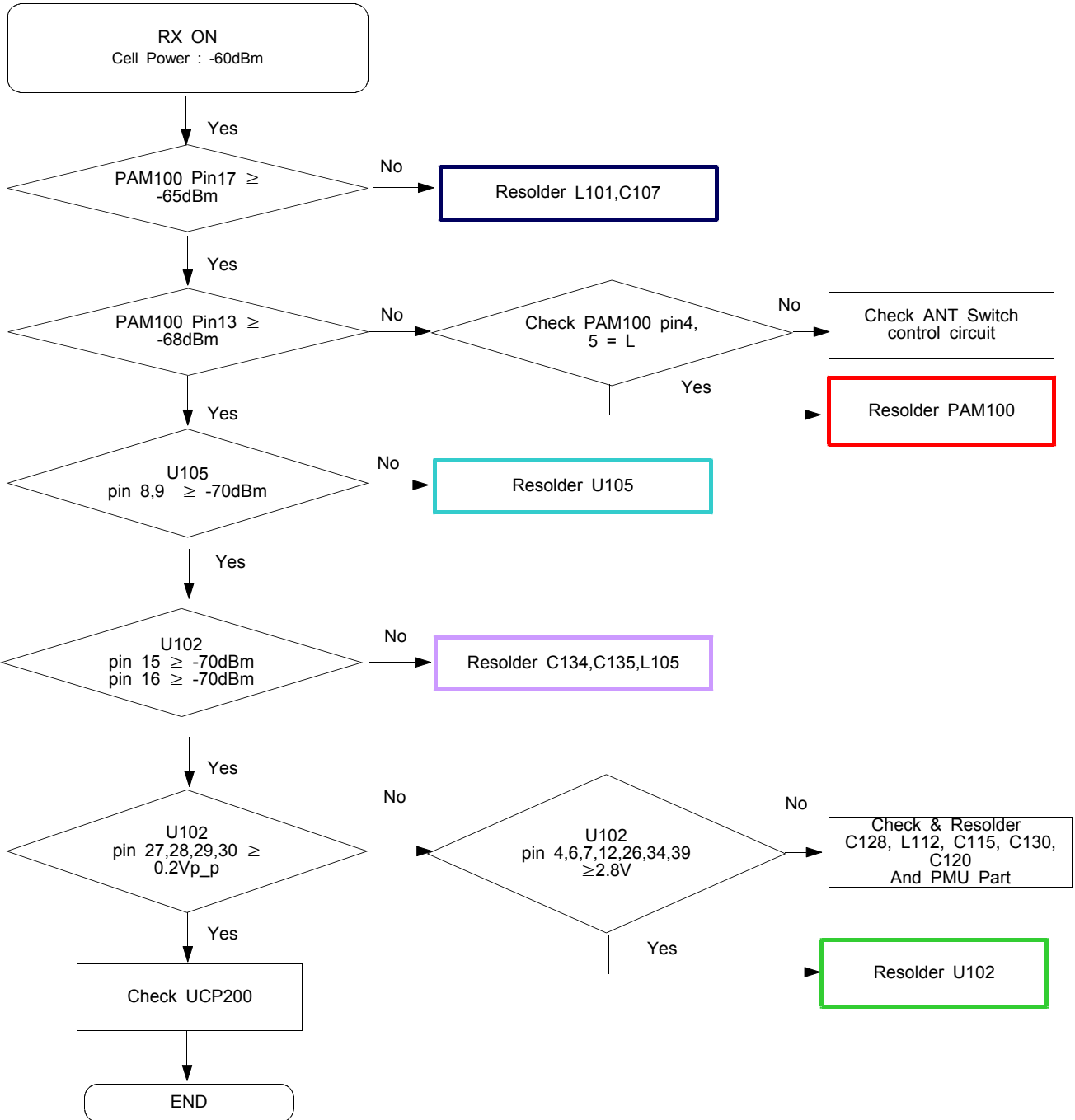

9-11. DCS Receiver

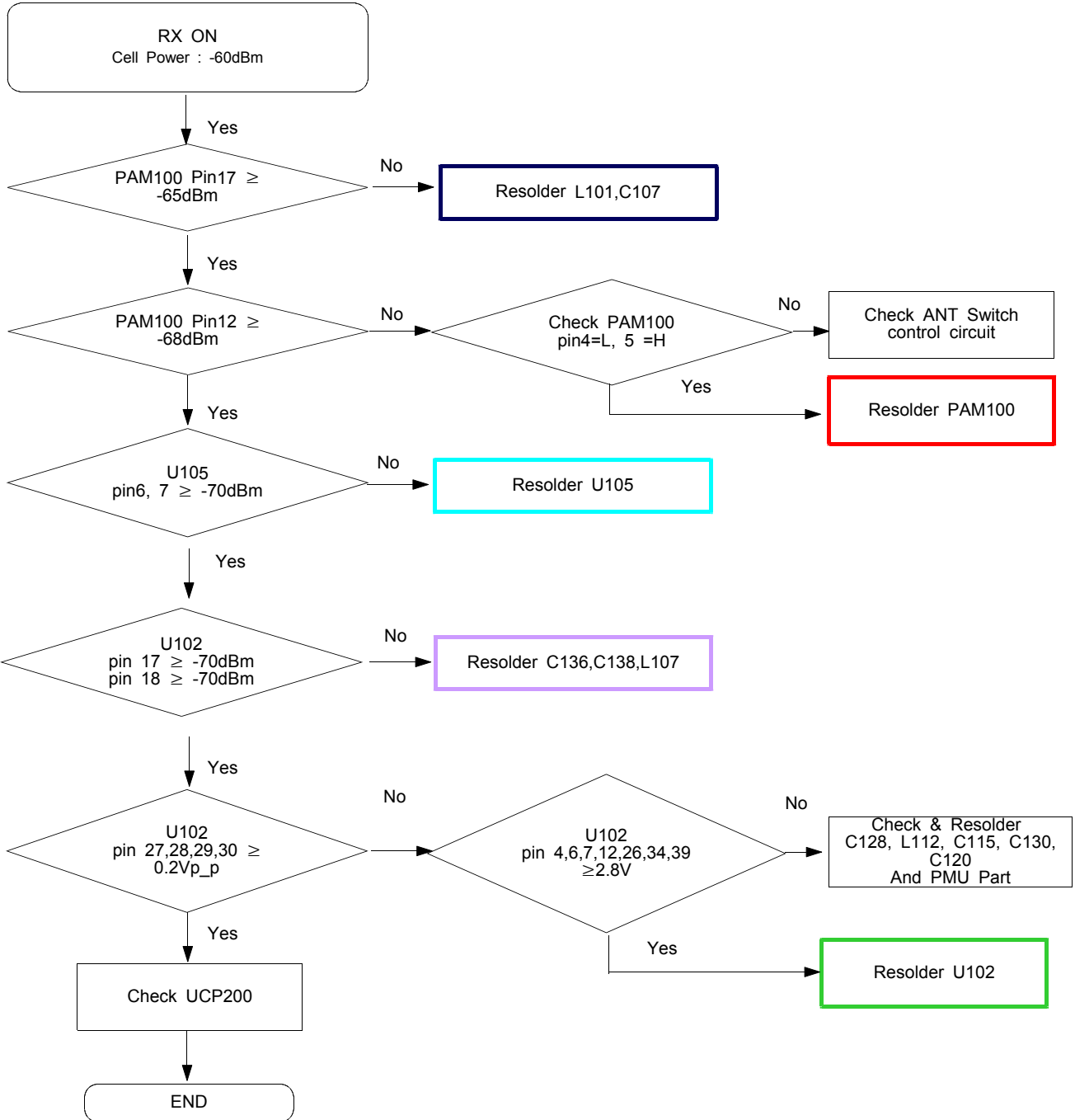

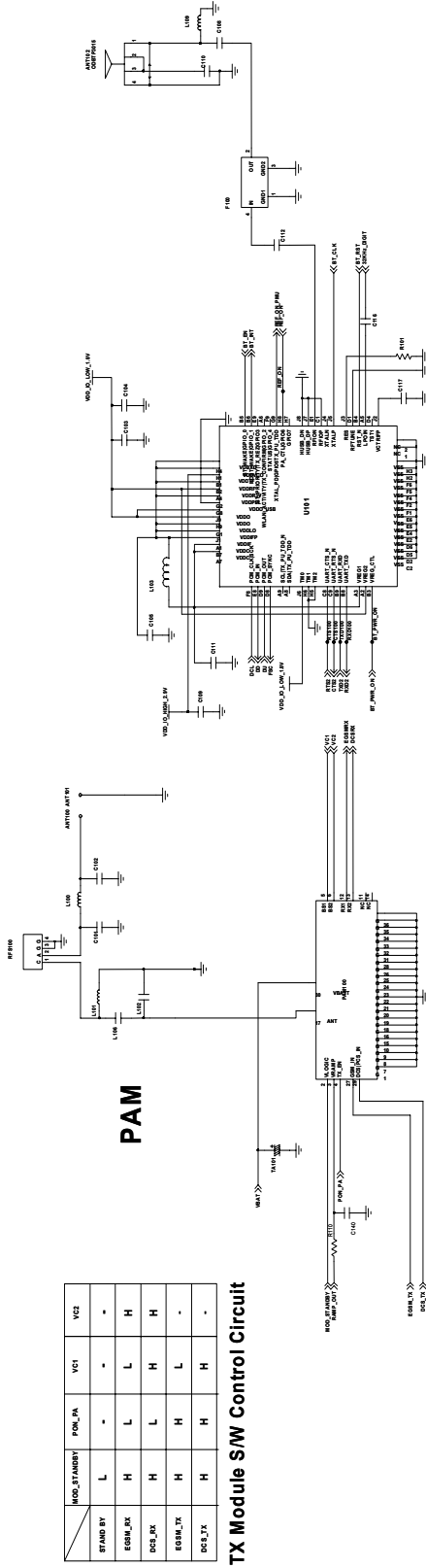

BLUETOOTH

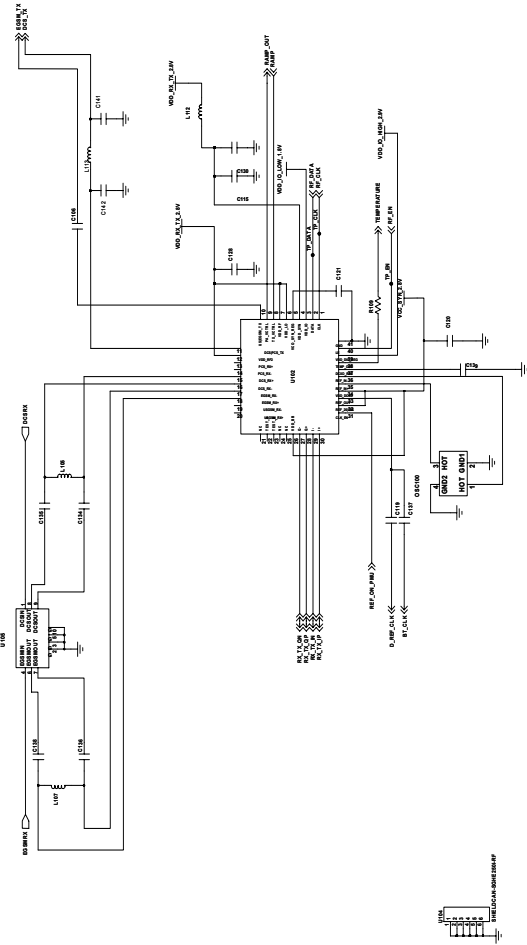

FM RADIO

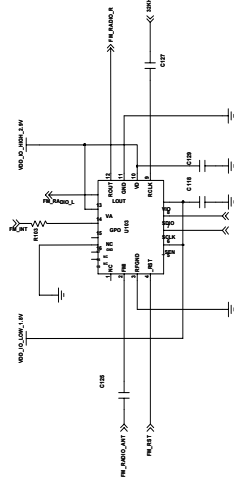

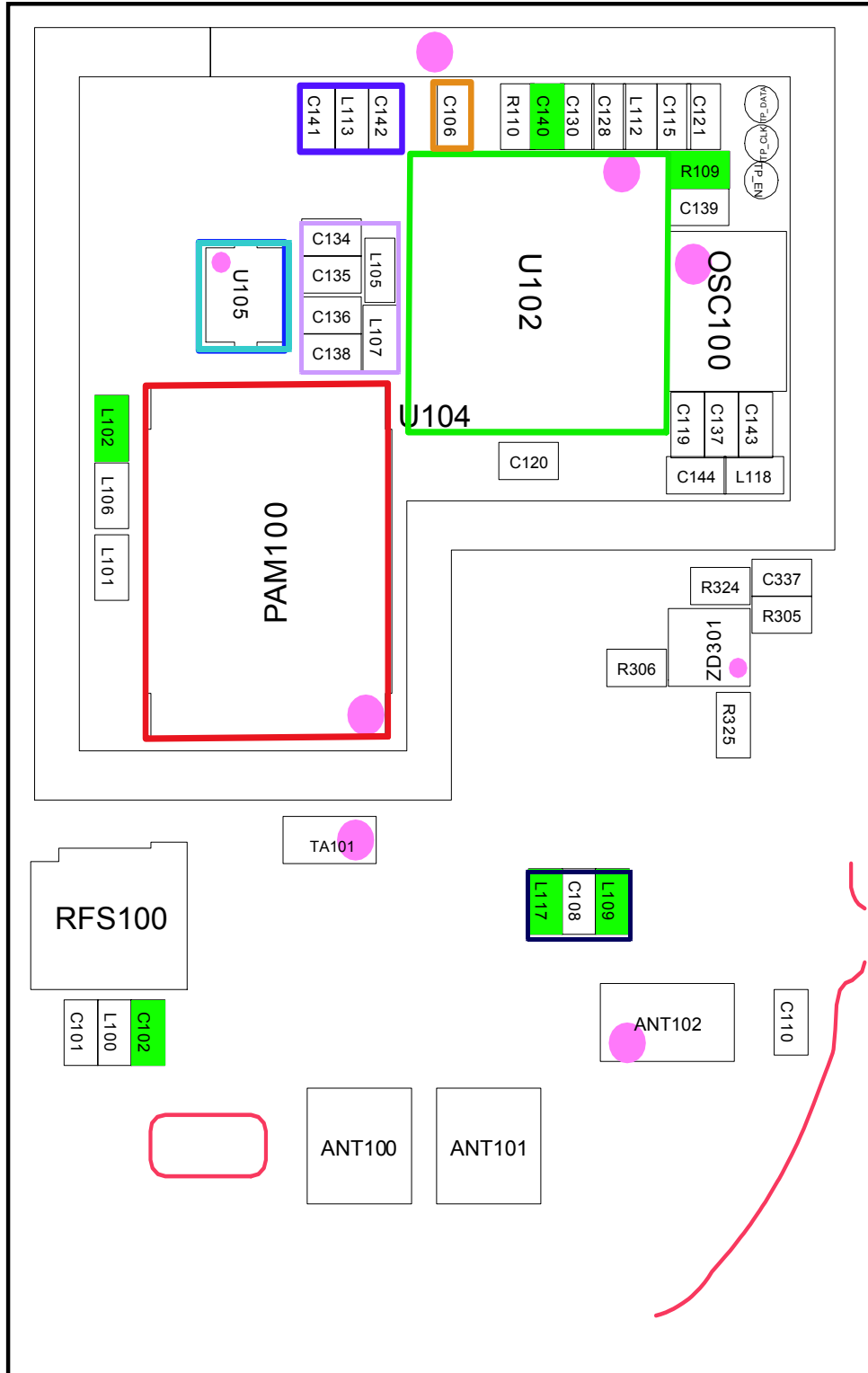

9-14. GSM900 Transmitter

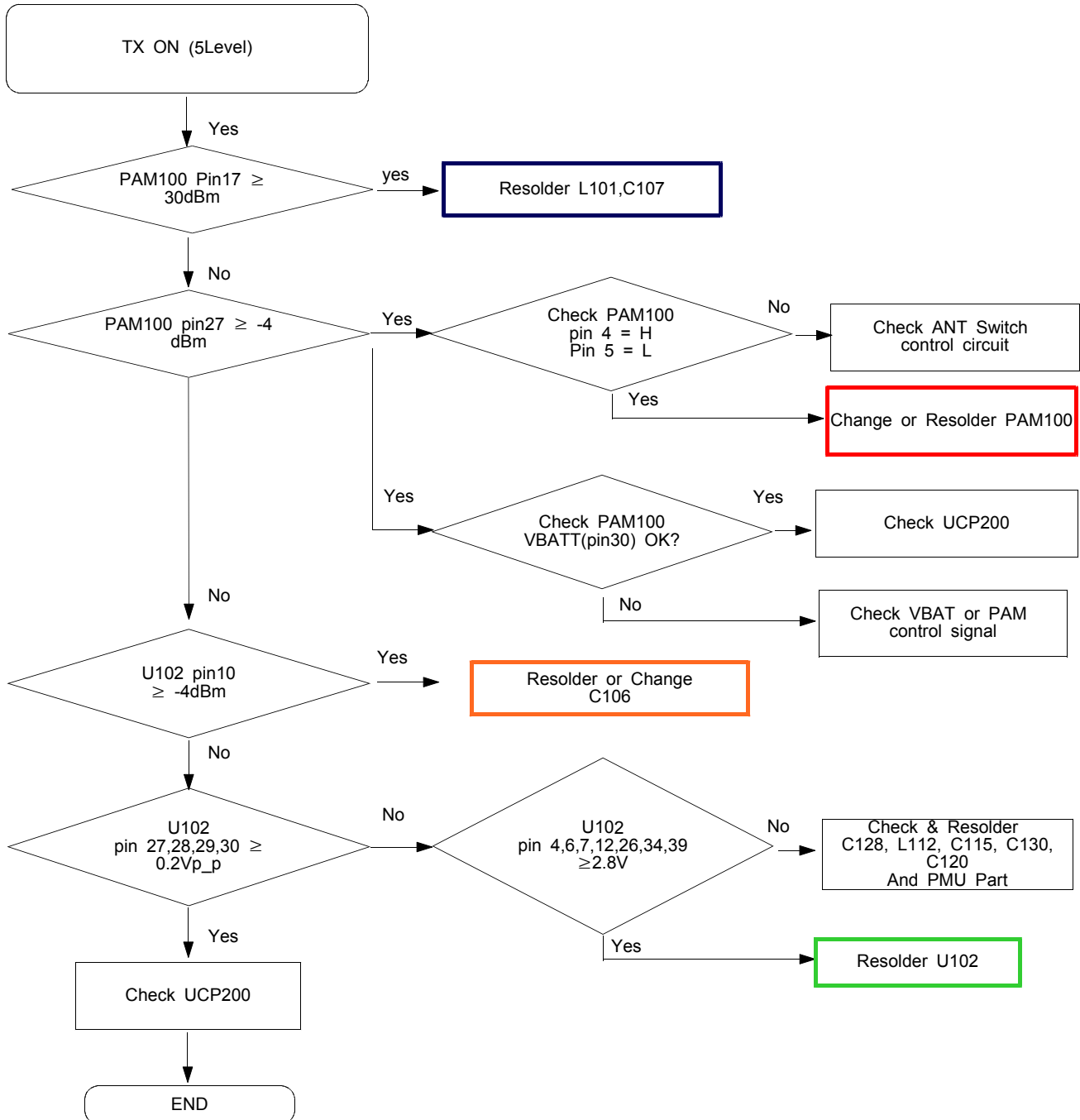

9-16. DCS Transmitter

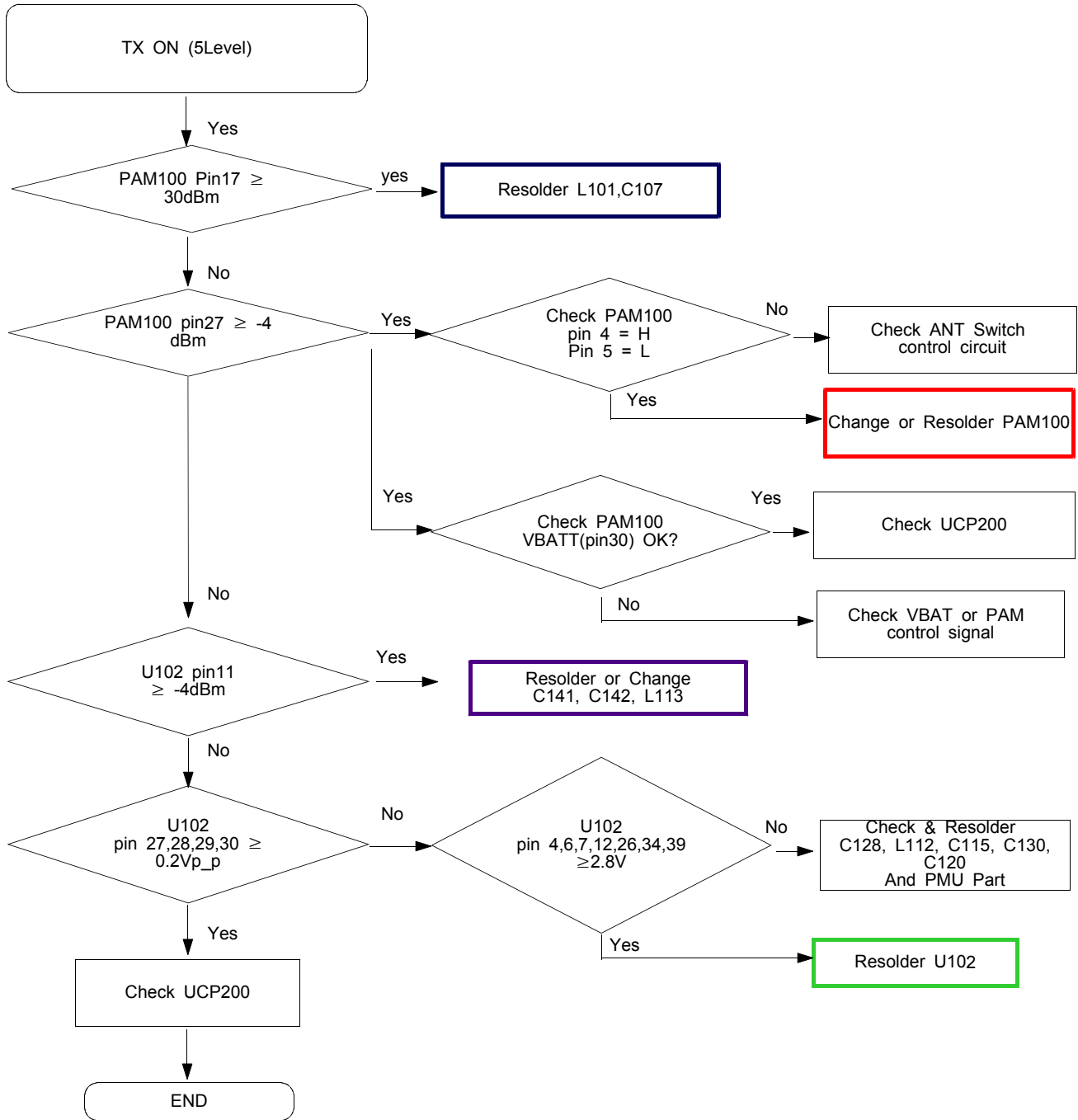

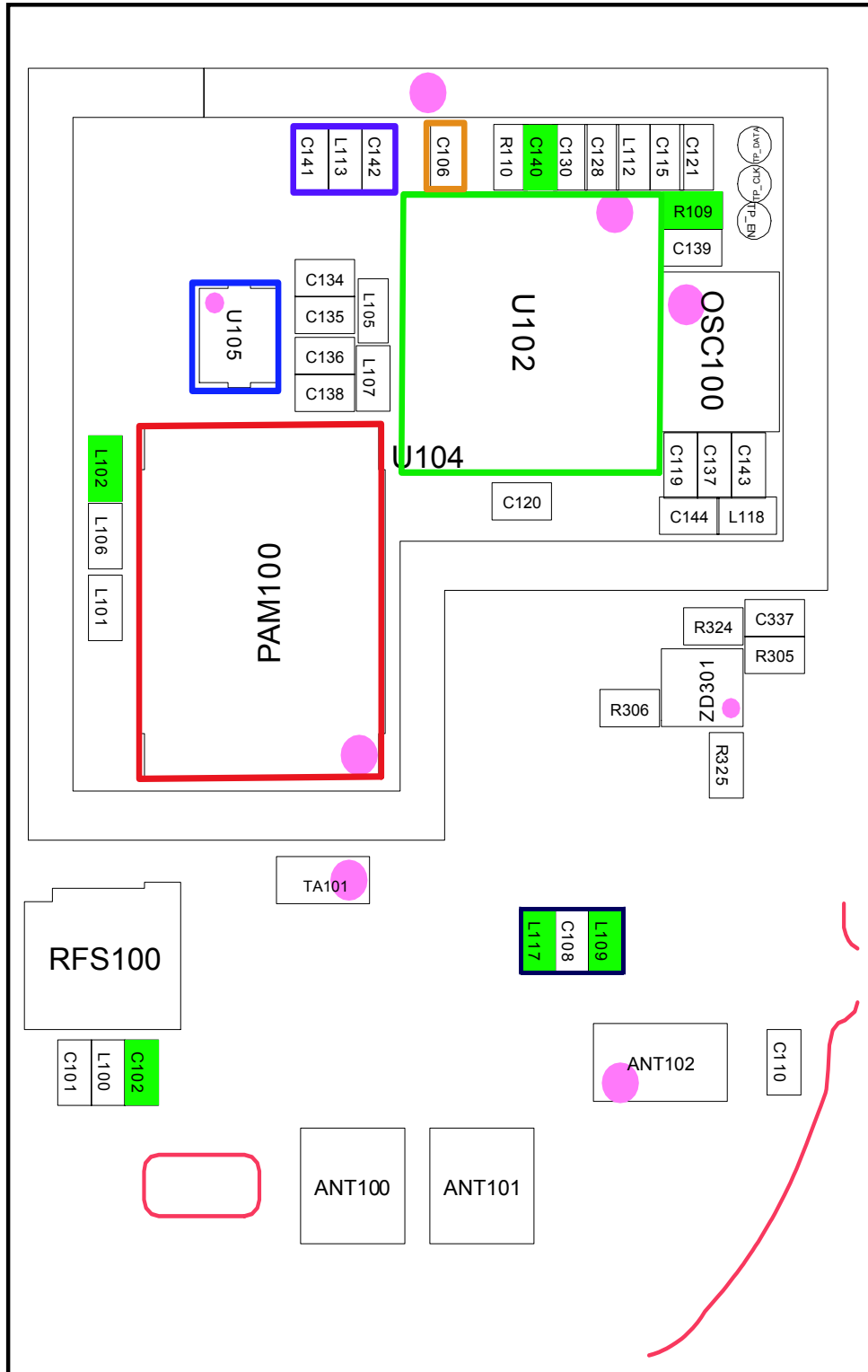

9-18. Bluetooth part

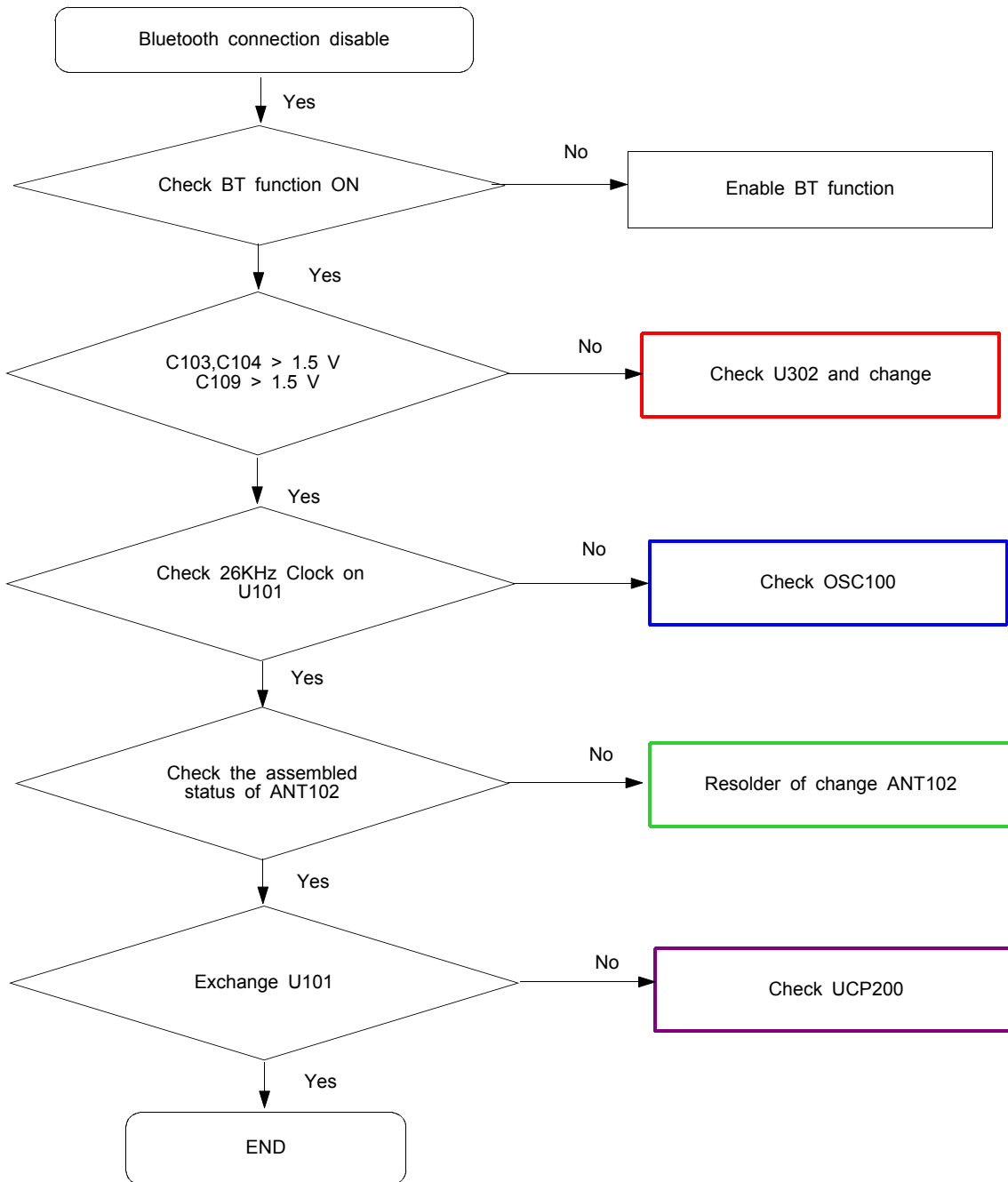

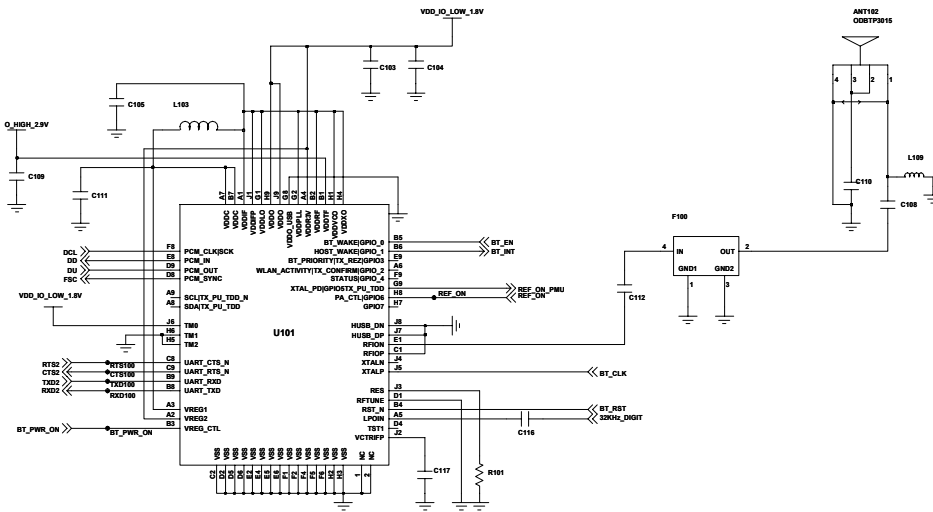

BLUETOOTH

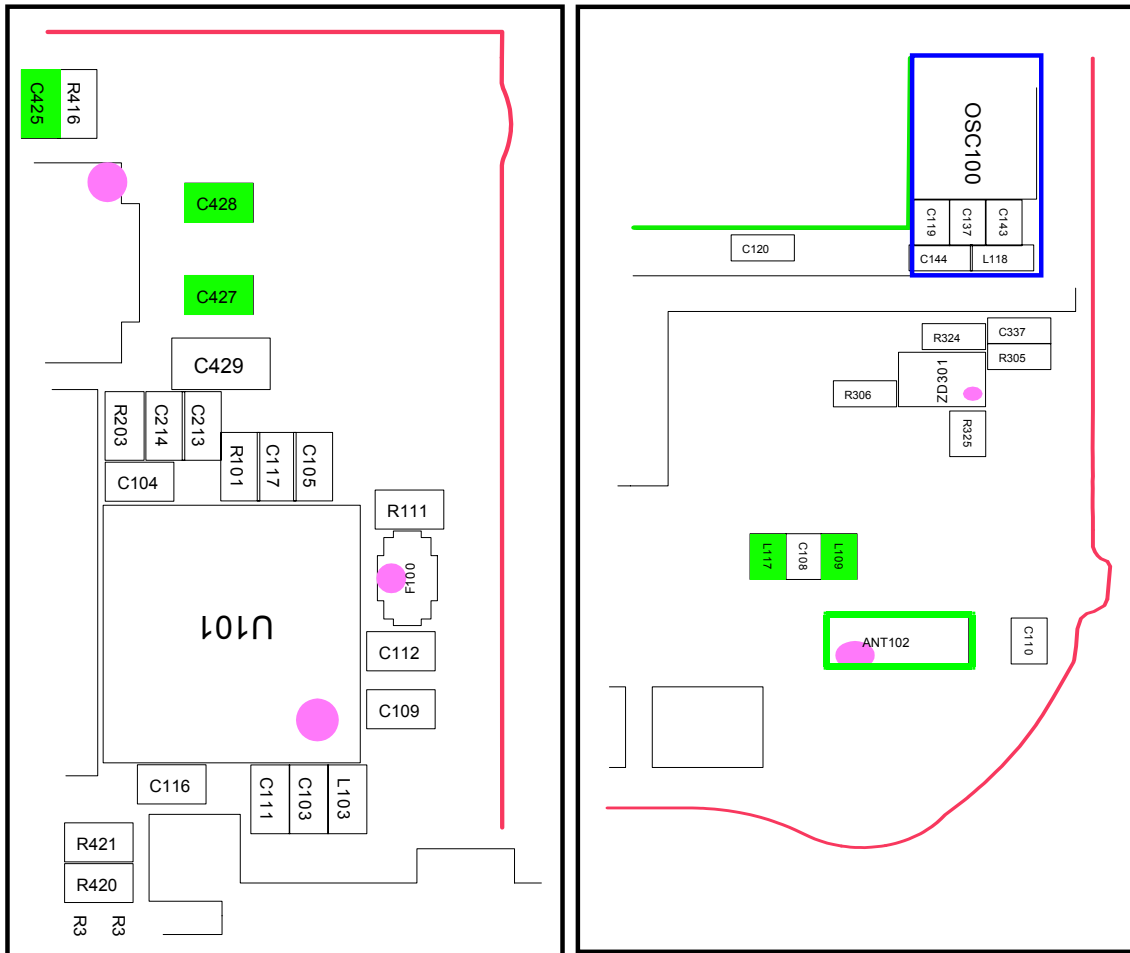

7. Block Diagrams

7-1. RF Block Diagram

SGH-E250i RF Block Diagram

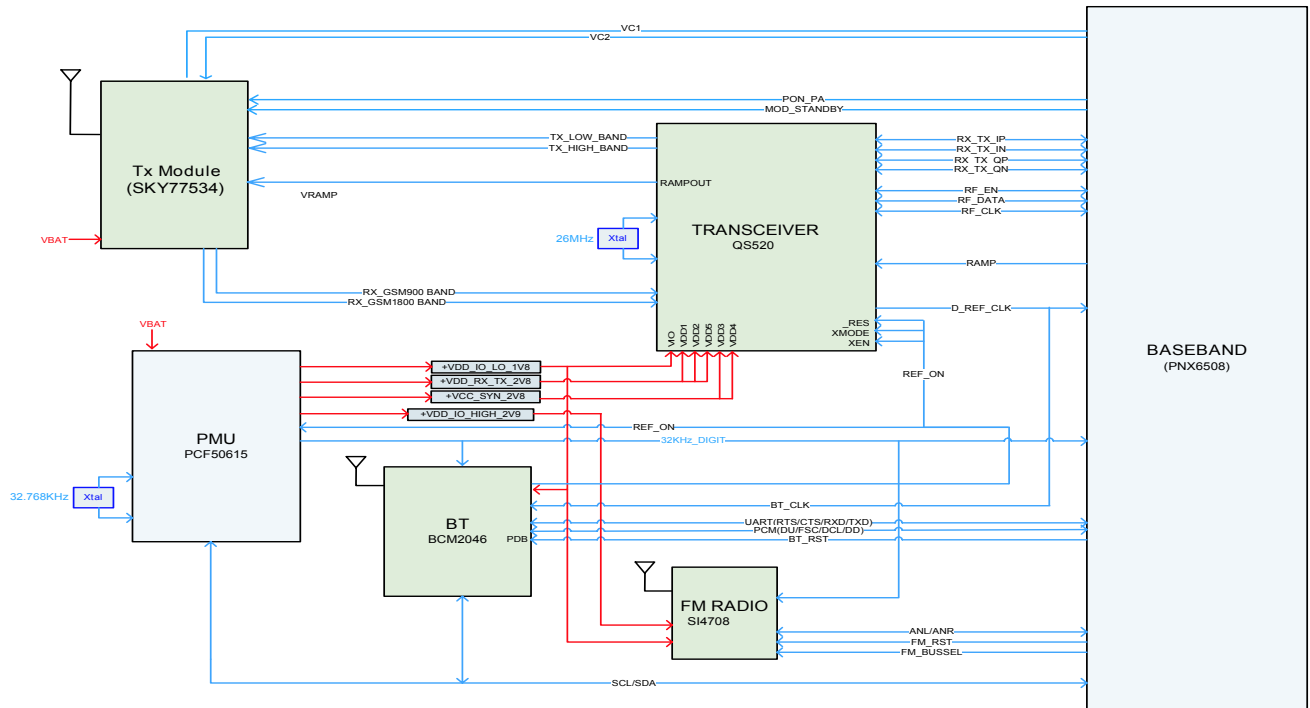

8. PCB Diagrams

