

SAMSUNG

GSM TELEPHONE
SGH-A500

SERVICE *Manual*

GSM TELEPHONE



CONTENTS

1. Specification
2. Exploded Views and Parts List
3. Electrical Parts List
4. Block Diagram
5. PCB Diagrams
6. Flow Chart of Troubleshooting and Circuit Diagrams

1. SGH-A500 Specification

1. GSM General Specification

	GSM900 Phase 1	EGSM 900 Phase 2	DCS1800 Phase 1
Freq. Band[MHz] Uplink/Downlink	890~915 935~960	880~915 925~960	1710~1785 1805~1880
ARFCN range	1~124	0~124 & 975~1023	512~885
Tx/Rx spacing	45MHz	45MHz	95MHz
Mod. Bit rate/ Bit Period	270.833kbps 3.692us	270.833kbps 3.692us	270.833kbps 3.692us
Time Slot Period/Frame Period	576.9us 4.615ms	576.9us 4.615ms	576.9us 4.615ms
Modulation	0.3GMSK	0.3GMSK	0.3GMSK
MS Power	33dBm~13dBm	33dBm~5dBm	30dBm~0dBm
Power Class	5pcl ~ 15pcl	5pcl ~ 19pcl	0pcl ~ 15pcl
Sensitivity	-102dBm	-102dBm	-100dBm
TDMA Mux	8	8	8
CELL RADIUS	35Km	35Km	2Km

2. GSM TX power class (@Normal condition)

TX Power control level	GSM900
5	33 ±2 dBm
6	31 ±3 dBm
7	29 ±3 dBm
8	27 ±3 dBm
9	25 ±3 dBm
10	23 ±3 dBm
11	21 ±3 dBm
12	19 ±3 dBm
13	17 ±3 dBm
14	15 ±3 dBm
15	13 ±3 dBm
16	11 ±5 dBm
17	9 ±5 dBm
18	7 ±5 dBm
19	5 ±5 dBm

TX Power control level	DCS1800
0	30 ±2 dBm
1	28 ±3 dBm
2	26 ±3 dBm
3	24 ±3 dBm
4	22 ±3 dBm
5	20 ±3 dBm
6	18 ±3 dBm
7	16 ±3 dBm
8	14 ±3 dBm
9	12 ±4 dBm
10	10 ±4 dBm
11	8 ±4dBm
12	6 ±4 dBm
13	4 ±4 dBm
14	2 ±5 dBm
15	0 ±5 dBm

2. SGH-A500 Exploded View and its Parts list

1. Cellular phone Exploded View

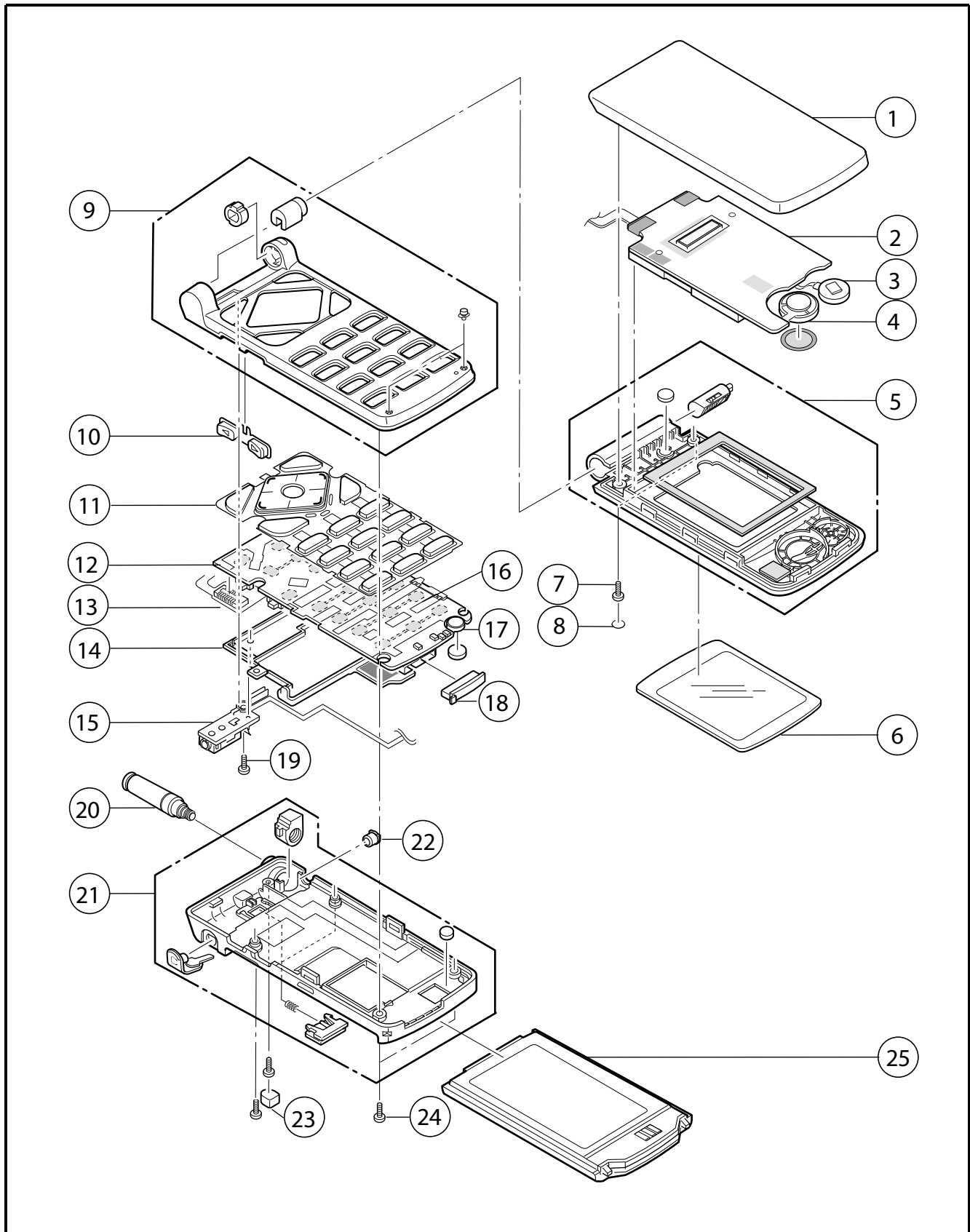

2. Cellular phone Parts list

Location NO.	Description	SEC CODE	Remark
1	FOLDER UPPER	GH75-02019A	
2	LCD	GH07-00198A	
3	MOTOR	3101-001239	
4	SPEAKER	3001-001272	
5	FOLDER LOWER	GH75-02018A	
6	WINDOW LCD	GH72-04519A	
7	SCREW	6001-001478	
8	SCREW SHEET	GH68-00370C	
9	FRONT COVER	GH75-02017A	
10	VOLUME KEY	GH75-01734A	
11	KEYPAD	GH75-02021A	
12	MAIN PBA	GH92-01299A	
13	CON TO CON FPCB	GH59-00524A	
14	SHIELD COVER	GH75-02210A	
15	EAR JACK FPCB	GH59-00525A	
16	DOME SHEET	GH59-00510A	
17	MIC	GH59-00491A	
18	CONNECTOR COVER	GH73-01132A	
19	SCREW	6001-001661	
20	ANTENNA	GH42-00225A	
21	REAR COVER	GH75-02020A	
22	RF TEST HOLE COVER	GH73-01348A	
23	RF SCREW HOLE COVER	GH73-00887A	
24	SCREW	6001-001155	
25	BATTERY	GH43-00669A	900mAH
		GH43-00670A	580mAH

3. Test Jig (GH80-01326A)

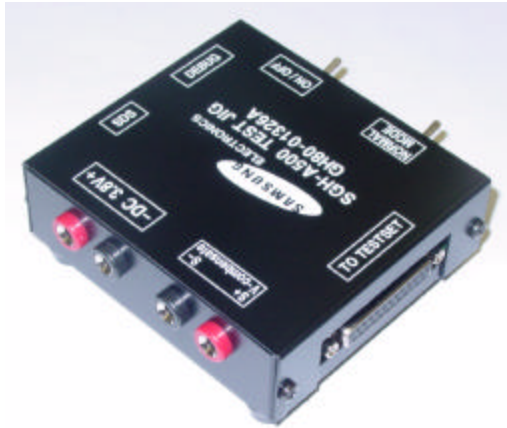

3-1. RF Test Cable
(GH39-00172A)



3-2. Test Cable
(GH39-00171A)



3-3. Serial Cable



3-4. Power Supply Cable



3-5. DATA CABLE
(PCB086LBE)



3-6. TA
(GH44-00171A)



3-7. Dongle Lock Key
(GH80-00815A)



3. SGH-A500 MAIN Electrical Parts List

Level	SEC Code	Design LOC	Descriptions
0	GH92-01299A	-	PBA MAIN-SGHA500 REV1.9B BOM
1	GH41-00259A	-	PCB-SGHA500;SGH-A500,FR-3,6L,-,1.00T,100X155
1	GH71-00846A	ANT1	NPR-ANT CONTACT;- ,SGH-A500,C1720C,T0.1,4.35
1	2203-000995	C101,C436	C-CERAMIC,CHIP;0.047nF,5%,50V,NP0,TP,1005
1	2203-000679	C102,C105,C108,C111	C-CERAMIC,CHIP;0.027nF,5%,50V,NP0,TP,1005
1	2203-001201	C103	C-CERAMIC,CHIP;0.007nF,0.5pF,50V,NP0,TP,1005
1	2203-000278	C104,C114	C-CERAMIC,CHIP;0.01nF,0.5pF,50V,NP0,TP,1005
1	2203-001124	C107	C-CERAMIC,CHIP;680pF,10%,50V,X7R,TP,1005,-
1	2203-005061	C109,C204,C215,C254	C-CERAMIC,CHIP;100nF,+80-20%,16V,Y5V,TP,1005
1	2203-000812	C110,C113	C-CERAMIC,CHIP;0.033nF,5%,50V,NP0,TP,1005
1	2203-005682	C112	C-CERAMIC,CHIP;0.033nF,5%,25V,NP0,TP,0603
1	2203-000233	C117,C120,C322	C-CERAMIC,CHIP;0.1nF,5%,50V,NP0,TP,1005
1	2203-000679	C118,C119,C122,C123	C-CERAMIC,CHIP;0.027nF,5%,50V,NP0,TP,1005
1	2203-000359	C121	C-CERAMIC,CHIP;0.15nF,5%,50V,NP0,TP,1005
1	2203-000679	C125,C126,C131,C205	C-CERAMIC,CHIP;0.027nF,5%,50V,NP0,TP,1005
1	2203-005054	C127	C-CERAMIC,CHIP;0.0047nF,0.25pF,50V,NP0,TP,100
1	2301-001589	C129	C-FILM,CHIP;18NF,20%,16V,TP,1608,-
1	2404-001268	C130,C309,C604	C-TA,CHIP;10UF,20%,10V,-,TP,2.2X1.25X1.0
1	2203-006053	C132	C-CERAMIC,CHIP;1000NF,10%,10V,X5R,TP,1608
1	2404-001239	C134,C614	C-TA,CHIP;100UF,20%,6.3V,WT,TP,3.3X2.7X1.7MM
1	2203-000386	C201,C235	C-CERAMIC,CHIP;0.015nF,5%,50V,NP0,TP,1005
1	2203-000254	C203,C389,C411,C412	C-CERAMIC,CHIP;10nF,10%,16V,X7R,TP,1005,-
1	2203-000679	C206,C207,C209,C210	C-CERAMIC,CHIP;0.027nF,5%,50V,NP0,TP,1005
1	2203-000679	C211,C212,C213,C214	C-CERAMIC,CHIP;0.027nF,5%,50V,NP0,TP,1005
1	2203-000679	C216,C218,C229,C255	C-CERAMIC,CHIP;0.027nF,5%,50V,NP0,TP,1005
1	2203-005288	C220	C-CERAMIC,CHIP;0.001nF,0.1pF,50V,NP0,TP,1005
1	2301-001590	C222	C-FILM,CHIP;10NF,20%,16V,TP,1608,-
1	2203-000330	C223,C225,C231	C-CERAMIC,CHIP;0.012nF,5%,50V,NP0,TP,1005
1	2203-001239	C224,C227	C-CERAMIC,CHIP;0.082nF,5%,50V,NP0,TP,1005
1	2203-005056	C228,C234	C-CERAMIC,CHIP;0.0068nF,0.25pF,50V,NP0,TP,100
1	2301-001230	C230	C-FILM,CHIP;10nF,5%,16V,TP,2012,-
1	2203-005450	C232,C236	C-CERAMIC,CHIP;0.0056nF,0.1pF,50V,NP0,TP,1005
1	2203-005382	C237	C-CERAMIC,CHIP;0.006nF,0.1pF,50V,NP0,TP,1005
1	2203-001221	C239	C-CERAMIC,CHIP;820pF,10%,50V,X7R,TP,1005,-
1	2203-002443	C241,C312,C226	C-CERAMIC,CHIP;0.33nF,10%,50V,X7R,TP,1005

Level	SEC Code	Design LOC	Descriptions
1	2203-005796	C246,C248,C605, C606	C- CERAMIC,CHIP;2200nF,10%,10V,X7R,TP,2012
1	2203-006090	C249,C601,C602	C- CERAMIC,CHIP;10000NF,10%,6.3V,X5R,TP,2012
1	2203-003027	C250	C- CERAMIC,CHIP;0.82nF,5%,50V,NP0,TP,1608
1	2203-005065	C301	C- CERAMIC,CHIP;1000nF,+80-20%,10V,Y5V,TP,160
1	2203-005050	C302	C- CERAMIC,CHIP;0.0018nF,0.25pF,50V,NP0,TP,100
1	2203-005482	C303,C310,C315, C317	C- CERAMIC,CHIP;100nF,10%,10V,X5R,TP,1005,-
1	2203-005717	C304,C305,C306, C307	C- CERAMIC,CHIP;0.027nF,5%,25V,NP0,TP,0603
1	2203-005480	C311	C- CERAMIC,CHIP;33nF,10%,10V,X7R,TP,1005,-
1	2203-005509	C313	C- CERAMIC,CHIP;330nF,+80-20%,10V,Y5V,TP,1005
1	2203-000438	C316	C- CERAMIC,CHIP;1nF,10%,50V,X7R,TP,1005,-
1	2203-000628	C318	C- CERAMIC,CHIP;0.022nF,5%,50V,NP0,TP,1005
1	2203-000679	C319,C321,C325, C439	C- CERAMIC,CHIP;0.027nF,5%,50V,NP0,TP,1005
1	2203-005717	C320	C- CERAMIC,CHIP;0.027nF,5%,25V,NP0,TP,0603
1	2203-000885	C330	C- CERAMIC,CHIP;4.7nF,10%,25V,X7R,TP,1005,-
1	2203-000854	C401	C- CERAMIC,CHIP;0.039nF,5%,50V,NP0,TP,1005
1	2203-005061	C404,C408,C410, C413	C- CERAMIC,CHIP;100nF,+80-20%,16V,Y5V,TP,1005
1	2203-002525	C407	C- CERAMIC,CHIP;0.56nF,10%,50V,X7R,TP,1005
1	2404-001105	C409,C432,C501	C- TA,CHIP;10UF,20%,6.3V,GP,TP,2012
1	2203-005061	C414,C416,C417, C418	C- CERAMIC,CHIP;100nF,+80-20%,16V,Y5V,TP,1005
1	2203-000425	C423,C428	C- CERAMIC,CHIP;0.018nF,5%,50V,NP0,TP,1005
1	2404-001281	C430,C431	C- TA,CHIP;22UF,20%,6.3V,WT,TP,2012
1	2203-000679	C443,C444,C448, C450	C- CERAMIC,CHIP;0.027nF,5%,50V,NP0,TP,1005
1	2404-001088	C445	C- TA,CHIP;2.2uF,20%,6.3V,GP,TP,2012,-
1	2203-005061	C447,C449,C477, C478	C- CERAMIC,CHIP;100nF,+80-20%,16V,Y5V,TP,1005
1	2203-000679	C479	C- CERAMIC,CHIP;0.027nF,5%,50V,NP0,TP,1005
1	2203-005061	C480,C502	C- CERAMIC,CHIP;100nF,+80-20%,16V,Y5V,TP,1005
1	2203-000940	C503	C- CERAMIC,CHIP;470pF,10%,50V,X7R,TP,1005,-
1	2203-005055	C510	C- CERAMIC,CHIP;0.0056nF,0.25pF,50V,NP0,TP,100
1	2203-005796	C607,C608,C609, C610	C- CERAMIC,CHIP;2200nF,10%,10V,X7R,TP,2012
1	2203-005796	C611	C- CERAMIC,CHIP;2200nF,10%,10V,X7R,TP,2012
1	2203-005482	C613	C- CERAMIC,CHIP;100nF,10%,10V,X5R,TP,1005,-
1	2203-001598	C615	C- CERAMIC,CHIP;2200nF,+80-20%,16V,Y5V,TP,201
1	4302-001130	C617	BATTERY-LI(2ND);3V,0.1MAH,-,-,3.1V,-
1	2203-005496	C630	C- CERAMIC,CHIP;220nF,+80-20%,10V,Y5V,TP,1005
1	2203-006093	C634	C- CERAMIC,CHIP;1000NF,+80-20%,6.3V,Y5V,TP,10

Level	SEC Code	Design LOC	Descriptions
1	3710-001866	CN301	CONNECTOR - SOCKET;3P, -,2.0MM, -,AU
1	3711-005151	CN302	CONNECTOR - HEADER;NOWALL,16P,2R,0.5MM, -,AU
1	3710-001611	CN303	CONNECTOR - SOCKET;18P,1R,0.5mm,SMD-A,AUF
1	3709-001187	CN401	CONNECTOR - CARD EDGE;6P,2.54MM,SMD-A,-
1	3705-001242	CON101	CONNECTOR - COAXIAL; -,JACK,100MOHM,50OHM,-
1	0404-001186	D101	DIODE - SCHOTTKY;BAT62-02W,40V,40MA,SCD80,TP
1	2011-001417	F101,F102	R-NETWORK;5.77/870OHM, -,0.04W,F,CHIP,4P,TP
1	4709-001144	F103	COUPLER - DIRECTION;897.5/1747.5MHZ,19DB/14DB
1	2011-001419	F104	R-NETWORK;44.8/131OHM, -,0.04W,F,CHIP,4P,TP
1	2011-001363	F105	R-NETWORK;50ohm, -,0.04W, -,CHIP,4P,TP
1	2904-001382	F201	FILTER - SAW;1.8425GHZ, -,2.2DB,TP,75MHZ/3.2DB,
1	2904-001383	F202	FILTER - SAW;942.5MHZ, -,1.8DB,TP,35MHZ/3.3DB,-
1	2904-001397	F204	FILTER - SAW;360MHZ, -,67.7KHZ/1.5DB,TP,3.3DB,-
1	2703-002198	L101	INDUCTOR - SMD;10NH,5%,1.0X0.5X0.5MM
1	3301-001362	L103,L213	CORE - FERRITE BEAD;AB,1kohm,1x0.5x0.5mm,50mA,TP,FER
1	2703-002369	L104	INDUCTOR - SMD;1.5NH,0.3NH,1.0X0.5X0.5MM
1	3301-001336	L105,L601	CORE - FERRITE BEAD;AB,220ohm,2x1.25x0.85mm,2000mA,T
1	2703-001802	L201	INDUCTOR - SMD;33UH,20%,2.0X1.25X1.25MM
1	2703-001944	L202,L203	INDUCTOR - SMD;27nH,10%,1.0x0.5x0.5mm
1	2703-001544	L204	INDUCTOR - SMD;39nH,5%,1.7x1.14x1.02
1	2703-001737	L205	INDUCTOR - SMD;2.7nH,0.3nH,1x0.5x0.5mm
1	2703-001233	L206	INDUCTOR - SMD;8.2uH,10%,1.6x0.8x0.8mm
1	2703-001178	L207,L208	INDUCTOR - SMD;3.3nH,0.3nH,1x0.5x0.5mm
1	2703-001970	L211	INDUCTOR - SMD;18nH,5%,1.0x0.5x0.5mm
1	2703-001685	L218	INDUCTOR - SMD;82nH,5%,1.7x1.14x1.02mm
1	2703-000172	L602	INDUCTOR - SMD;22UH,10%,2.5X3.2X2MM
1	0601-001540	LED13	LED;CHIP,BLUE,1.1X0.8MM,485NM
1	0601-001402	LED14	LED;CHIP,RED/Y-GRN,1.2x1.5mm,660/570nm
1	0601-001547	LED501,LED502, LED503	LED;CHIP,BLUE,1.1X0.8MM,468NM
1	0601-001547	LED504,LED505, LED506	LED;CHIP,BLUE,1.1X0.8MM,468NM
1	0601-001547	LED507,LED508, LED509	LED;CHIP,BLUE,1.1X0.8MM,468NM
1	0601-001547	LED510,LED511, LED512	LED;CHIP,BLUE,1.1X0.8MM,468NM
1	0601-001547	LED513,LED514, LED515	LED;CHIP,BLUE,1.1X0.8MM,468NM
1	0601-001547	LED516	LED;CHIP,BLUE,1.1X0.8MM,468NM
1	2806-001297	OSC101	OSCILLATOR - VCO;1748MHZ, -,50OHM,TP,2.8V,40MA
1	2806-001285	OSC201	OSCILLATOR - VCO;1.320GHZ, -,50OHM,TP,2.75V,11

Level	SEC Code	Design LOC	Descriptions
1	2809-001264	OSC202	OSCILLATOR-VCTCXO;13MHZ,-,10KOHM//10PF,TP,
1	2801-003856	OSC401	CRYSTAL-SMD;0.032768MHZ,20PPM,28-ACP,7PF,6
1	0504-001133	Q103	TR-DIGITAL;BCR135T,NPN,250MW,10K/47K,SC-75,T
1	0504-001134	Q502,Q503,Q506	TR-DIGITAL;BCR133T,NPN,250MW,10K/10K,SC-75,
1	0502-001201	Q601	TR-POWER;ZXT13P20DE6,PNP,1100MW,SOT-23-6,T
1	0504-001122	Q602	TR-DIGITAL;DTC123JE,NPN,150MW,17/26,EMT3,TP
1	2007-001298	R101	R-CHIP;51ohm,5%,1/16W,DA,TP,1005
1	2007-000140	R107,R113,R114, R202	R-CHIP;1Kohm,5%,1/16W,DA,TP,1005
1	2007-000775	R108,R450,R453	R-CHIP;33Kohm,5%,1/16W,DA,TP,1005
1	2007-001311	R109	R-CHIP;270ohm,5%,1/16W,DA,TP,1005
1	2007-000139	R110,R111,R569	R-CHIP;220ohm,5%,1/16W,DA,TP,1005
1	2007-007771	R118,R204,R205, R206	R-CHIP;0OHM,5%,1/16W,DA,TP,1005
1	2007-001301	R121	R-CHIP;68ohm,5%,1/16W,DA,TP,1005
1	2007-000140	R203,R211,R213, R301	R-CHIP;1Kohm,5%,1/16W,DA,TP,1005
1	2007-000146	R207,R216,R218, R222	R-CHIP;6.8Kohm,5%,1/16W,DA,TP,1005
1	2007-007313	R208	R-CHIP;6.8Kohm,1%,1/16W,DA,TP,1005
1	2007-007309	R209	R-CHIP;12Kohm,1%,1/16W,DA,TP,1005
1	2007-000148	R212,R410,R502	R-CHIP;10Kohm,5%,1/16W,DA,TP,1005
1	2007-001320	R215	R-CHIP;1.8Kohm,5%,1/16W,DA,TP,1005
1	2007-000173	R220,R221	R-CHIP;22ohm,5%,1/16W,DA,TP,1005
1	2007-000142	R225	R-CHIP;2.7Kohm,5%,1/16W,DA,TP,1005
1	2007-000153	R226,R418	R-CHIP;22Kohm,5%,1/16W,DA,TP,1005
1	2007-000141	R227,R427,R412	R-CHIP;2.2Kohm,5%,1/16W,DA,TP,1005
1	2007-000140	R302,R303,R304, R306	R-CHIP;1Kohm,5%,1/16W,DA,TP,1005
1	2007-000162	R305,R411,R416	R-CHIP;100Kohm,5%,1/16W,DA,TP,1005
1	2007-000140	R307,R604,R610	R-CHIP;1Kohm,5%,1/16W,DA,TP,1005
1	2007-000164	R308,R402	R-CHIP;150Kohm,5%,1/16W,DA,TP,1005
1	2007-000155	R309,R310	R-CHIP;27Kohm,5%,1/16W,DA,TP,1005
1	2007-007771	R312,R313,R405, R414	R-CHIP;0OHM,5%,1/16W,DA,TP,1005
1	2007-000156	R315,R317,R408	R-CHIP;30Kohm,5%,1/16W,DA,TP,1005
1	2007-000159	R330	R-CHIP;56Kohm,5%,1/16W,DA,TP,1005
1	2007-000152	R340,R603	R-CHIP;20Kohm,5%,1/16W,DA,TP,1005
1	2007-007193	R403,R404	R-CHIP;5.1OHM,5%,1/16W,DA,TP,1005
1	2007-000758	R409	R-CHIP;330Kohm,5%,1/16W,DA,TP,1005
1	2007-000566	R413	R-CHIP;220Kohm,5%,1/16W,DA,TP,1005
1	2007-007200	R415	R-CHIP;2.4OHM,5%,1/16W,DA,TP,1005
1	2007-000242	R428,R429	R-CHIP;1.5Kohm,5%,1/16W,DA,TP,1005

Level	SEC Code	Design LOC	Descriptions
1	2007-000170	R452	R- CHIP;1Mohm,5%,1/16W,DA,TP,1005
1	2007-001290	R501,R503,R522, R523	R- CHIP;24ohm,5%,1/16W,DA,TP,1005
1	2007-007014	R506	R- CHIP;51KOHM,5%,1/16W,DA,TP,1005
1	2007-001307	R512,R513,R520, R521	R- CHIP;180ohm,5%,1/16W,DA,TP,1005
1	2007-001307	R524,R525,R526, R527	R- CHIP;180ohm,5%,1/16W,DA,TP,1005
1	2007-001307	R528,R529,R530, R531	R- CHIP;180ohm,5%,1/16W,DA,TP,1005
1	2007-000138	R567	R- CHIP;100ohm,5%,1/16W,DA,TP,1005
1	2007-003030	R568	R- CHIP;91ohm,5%,1/16W,DA,TP,1005
1	2007-007483	R602	R- CHIP;154Kohm,1%,1/16W,DA,TP,1005
1	2007-008500	R606	R- CHIP;0.1OHM,1%,1/4W,DA,TP,3216
1	2007-000157	R609	R- CHIP;47Kohm,5%,1/16W,DA,TP,1005
1	2007-008117	R611	R- CHIP;2.7Kohm,1%,1/16W,DA,TP,1005
1	2909-001174	U101	FILTER - DUPLEXER;942.5MHZ,897.5MHZ,1.2/1.4DB,
1	1209-001429	U102	IC - ETC, LINEAR;PCF5079HK/C/1,SOT-650,10P,118MIL,PL
1	1201-001754	U103	IC - POWER AMP; -,MCM,16P, -, -, -, PLASTIC,7V, -, -25TO+10
1	0504-001130	U104,U105,U605	TR - DIGITAL;BCR35PN,NPN/PNP,250MW,10K/47K,SO
1	1205-002203	U201	IC - TRANSCEIVER;PMB6253V1.1,VQFN,48P,7X7MM,P
1	1109-001207	U302	IC - ETC. MEMORY;1380,32MX16/4MX16BIT,CSP,72P, -,85NS
1	1204-001811	U303	IC - MELODY;YMU759-QE2,QFN,32P, -, PLASTIC,6V, -,
1	0902-001560	U401	IC - MICROPROCESSOR; -,16BIT,P-LFBGA-200-1,200
1	1202-001036	U410	IC - VOLTAGE COMP.;75W56,SSOP,8P,90MIL,DUAL,+ -7V,CMO
1	1009-001010	U501	IC - HALL EFFECT S/W;A3212ELH-SAMSUNG,SC-59A,3P,82MI
1	1203-002644	U601	IC - BATTERY;PMB6810V1.73,VQFN,40P,6.5X5.5MM,P
1	1203-002127	U602	IC - BATTERY;1734,SOT-23,6P,150MIL,PLASTIC,4.7/5
1	1203-001518	U603	IC - VOLTAGE REGULATOR;5219,SOT-23,5P,63MIL,PLASTIC,
1	1405-001082	V1,V3,V4,ZD301	VARISTOR;5.6V,20A,1x0.5x0.6mm,TP
1	3404-001152	VOL_DN,VOL_UP	SWITCH - TACT;12V DC,20mA,160gf,4.5x4.0x2.3mm,SPST
1	0406-001104	ZD302,ZD500,ZD5 01	DIODE - TVS;ESDA6V1-5W6,6.1/-/7.2V,100W,SOT-32
1	0406-001144	ZD304	DIODE - TVS;ESDA6V1-4F1,6.1/-/7.2V,150W,CSP
1	0406-001104	ZD502,ZD503	DIODE - TVS;ESDA6V1-5W6,6.1/-/7.2V,100W,SOT-32

4. SGH-A500 Block Diagram

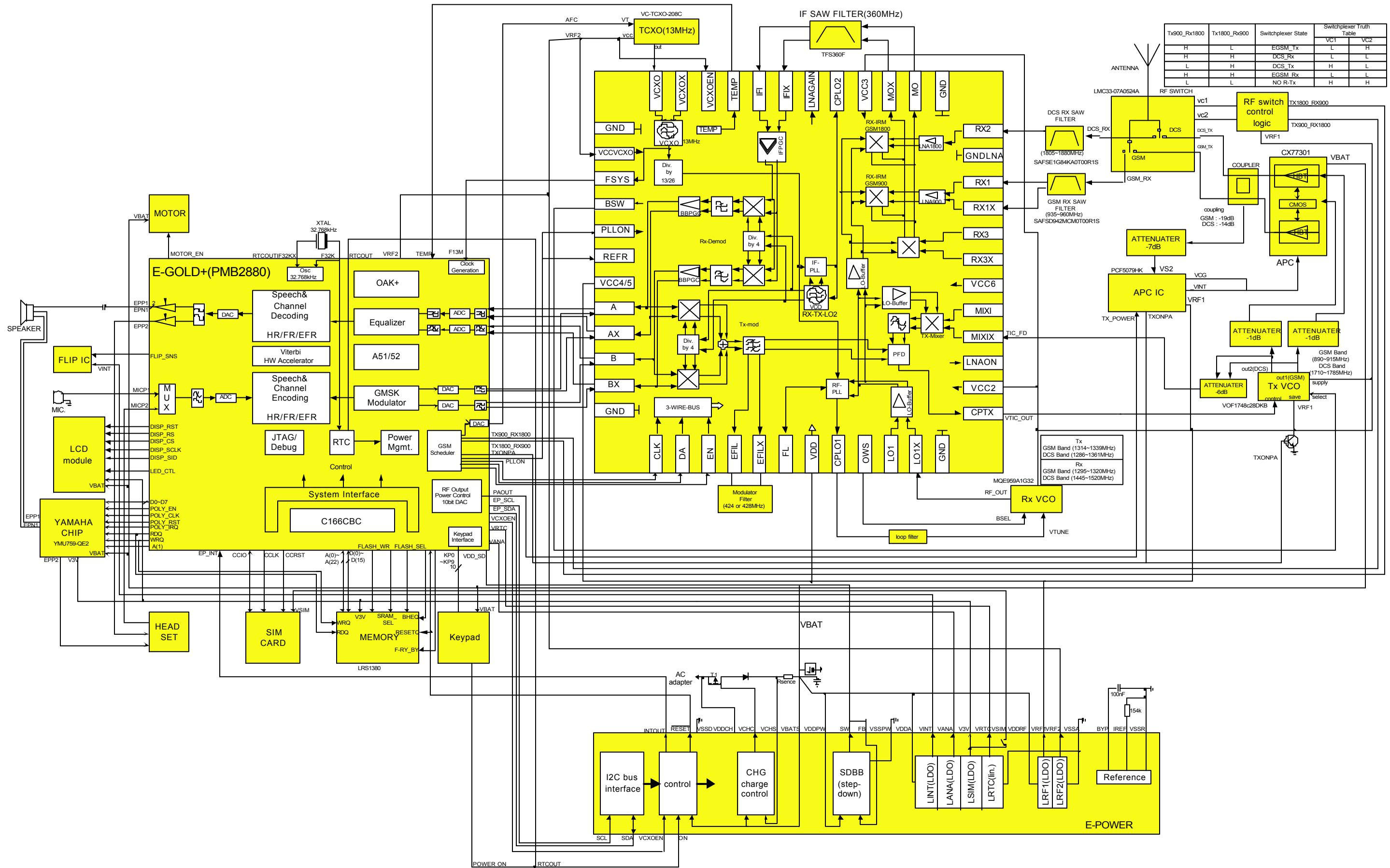

5. SGH-A500 PCB Diagrams

1. Main PCB Top Diagram

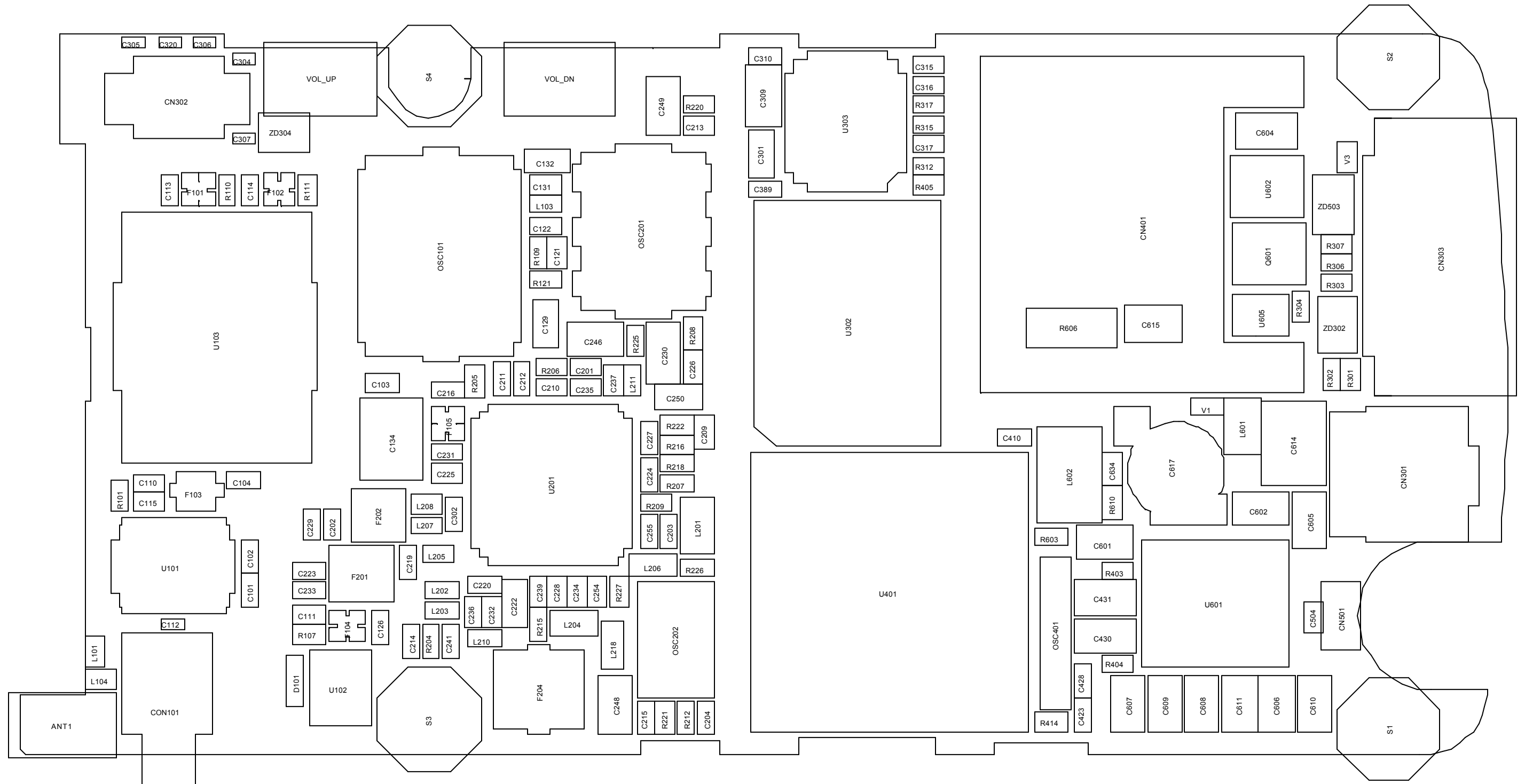

2. Main PCB Bottom Diagram

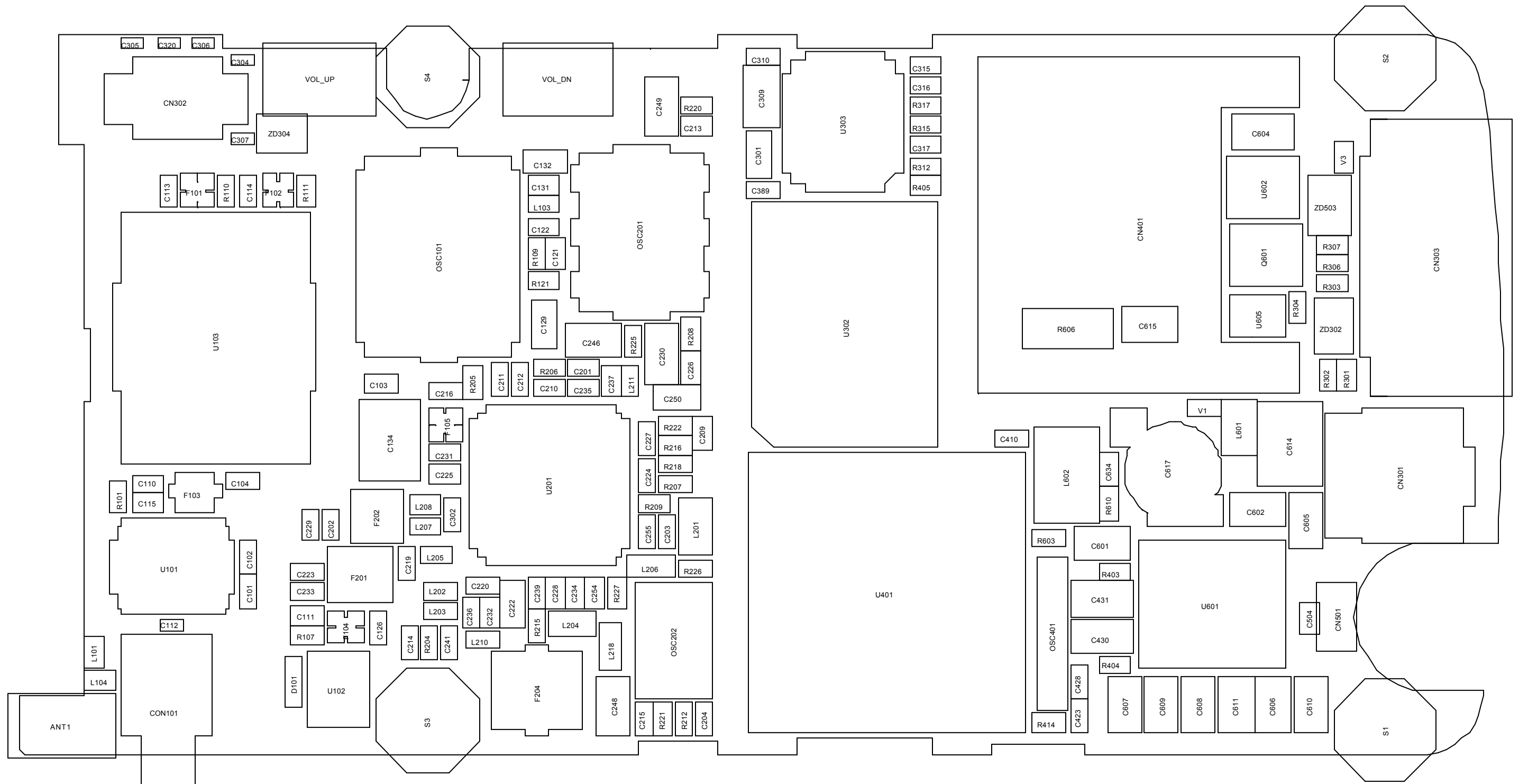

6. SGH-A500 Flow Chart of Troubleshooting and Circuit Diagrams

1. Power On

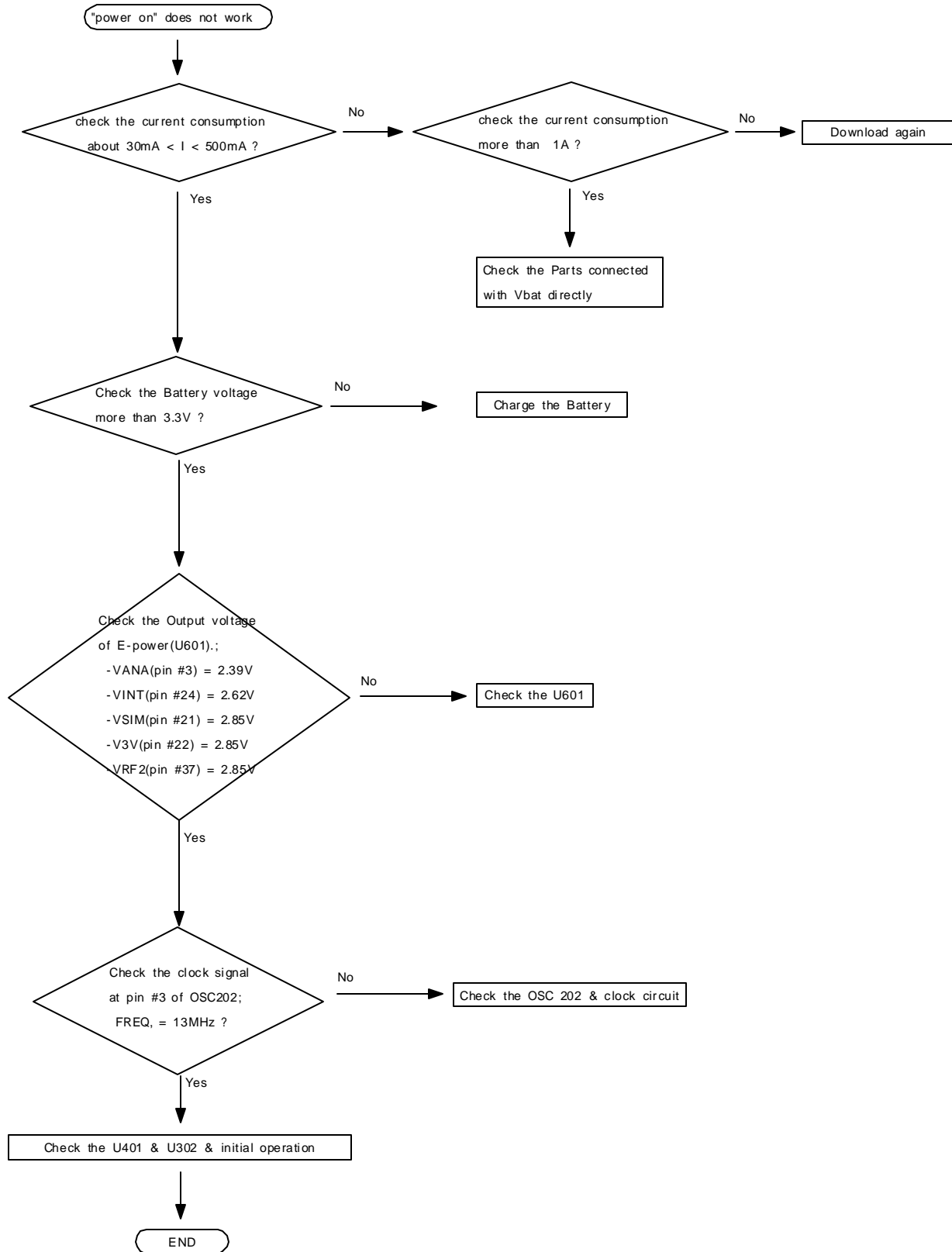

2. Initial

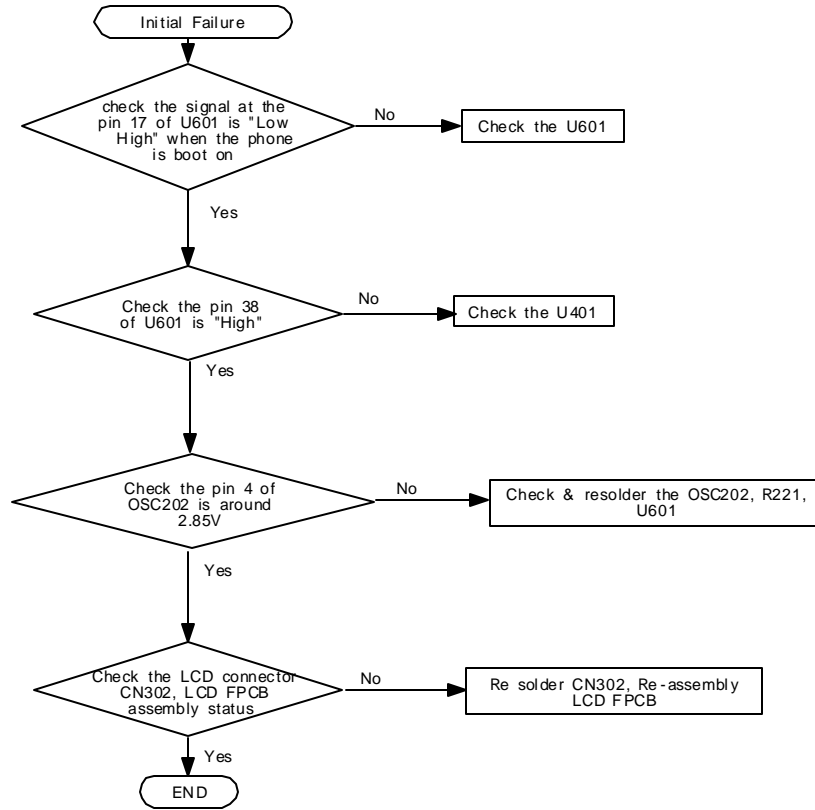

3. Sim Part

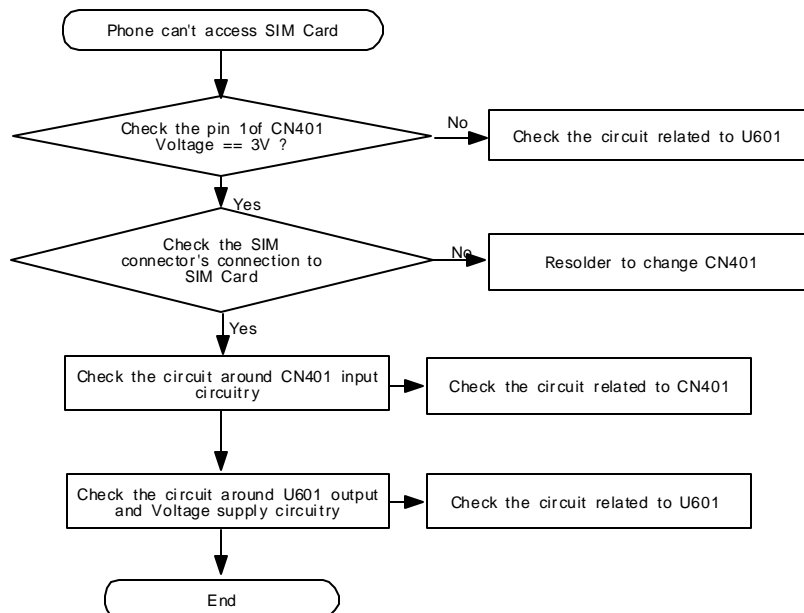

4. Charging Part

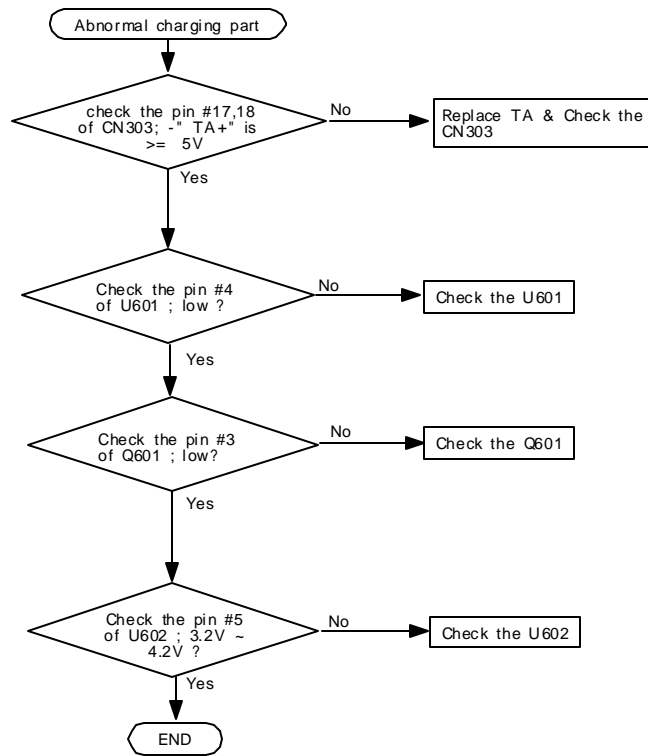

5. Microphone Part

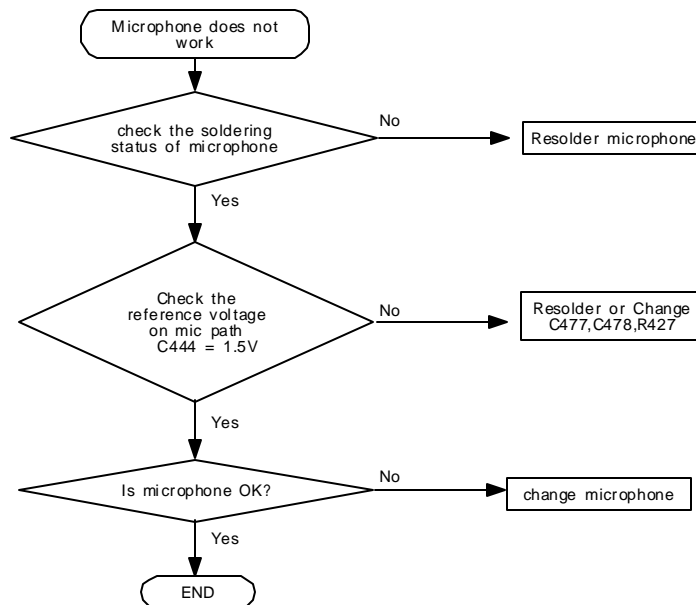

6. Speaker Part

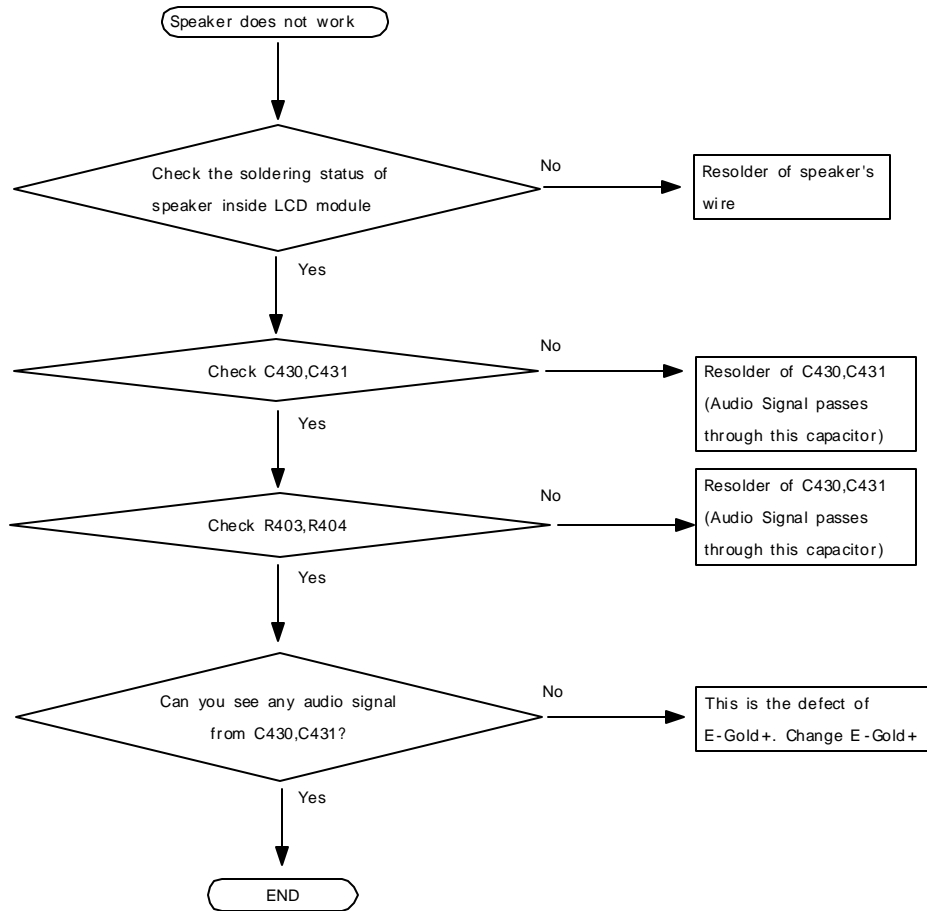

7. Backlight PART

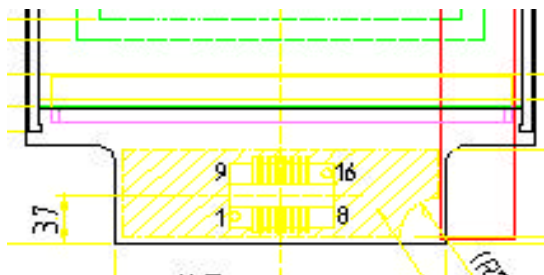
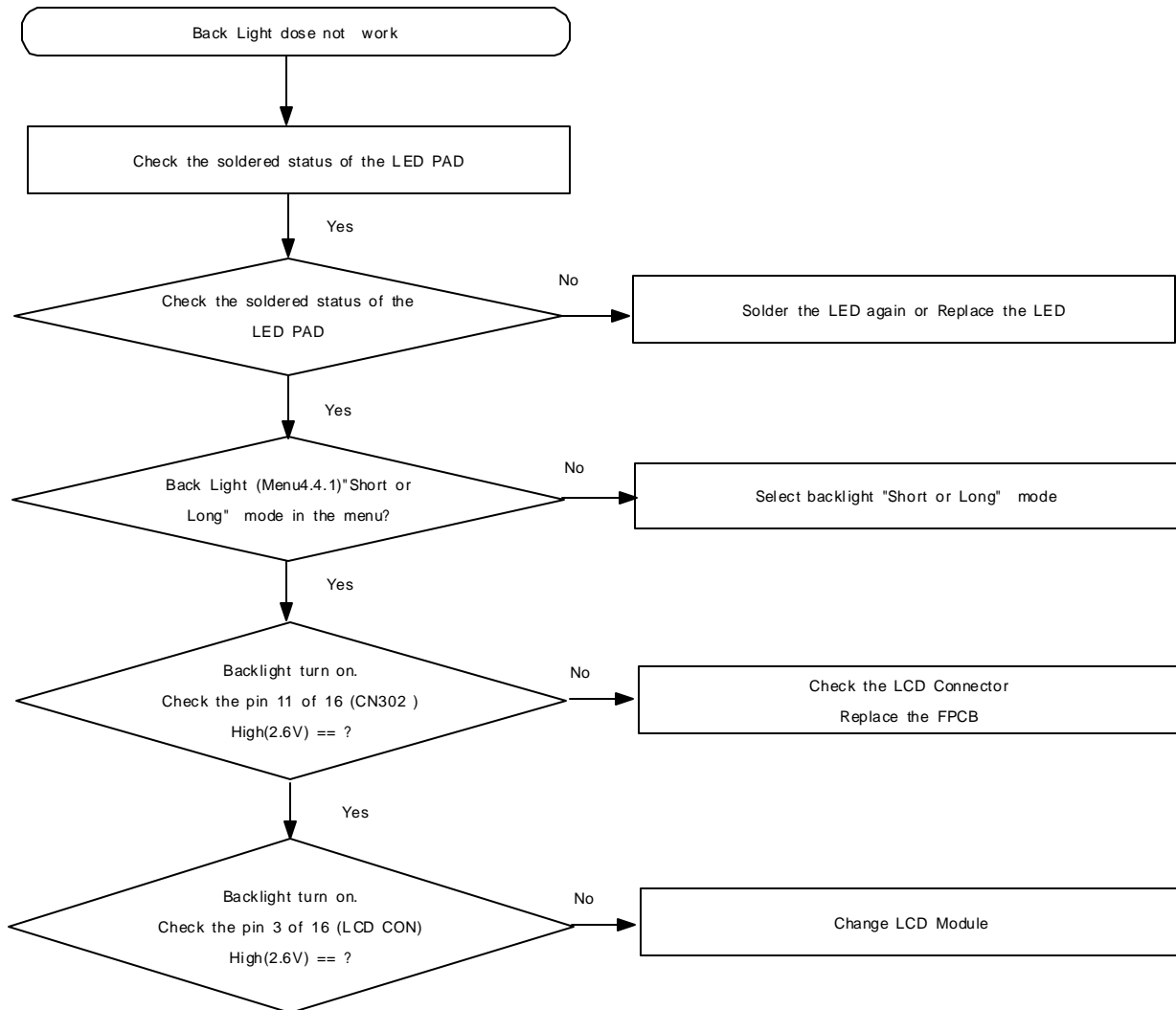

LCD
1. VBAT 2. VBAT 3. LED_IN

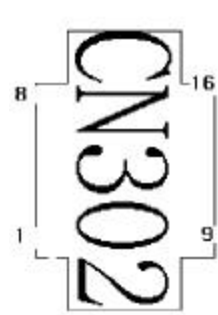

Main Board
9. VBAT 10. VBAT 11. LED_IN

8. Alert Tone

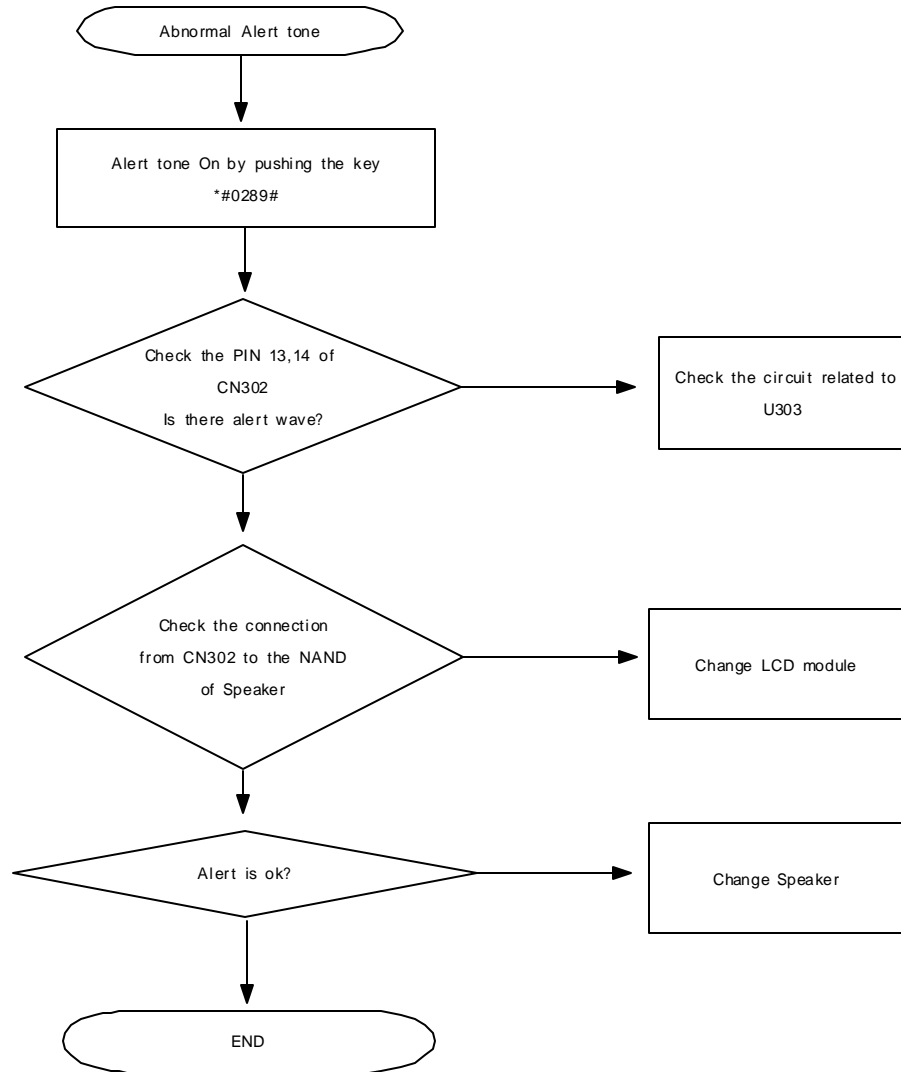

9. GSM Receiver

<Test Condition>
 1. Phone Tool Inline Mode :
 - RF Mode : Rx Continuous.
 - ARFCN : Rx 62Ch.
 - Gain : Rx 88.
 2. Generator RF Level :-50dBm.
 3. Measure with Hewlett Packard 85024A active high frequency probe.
 Measured Value is dependent on Probe Measured Point of Component.

Flow Chart.(GSM : Rx Trouble Shooting)

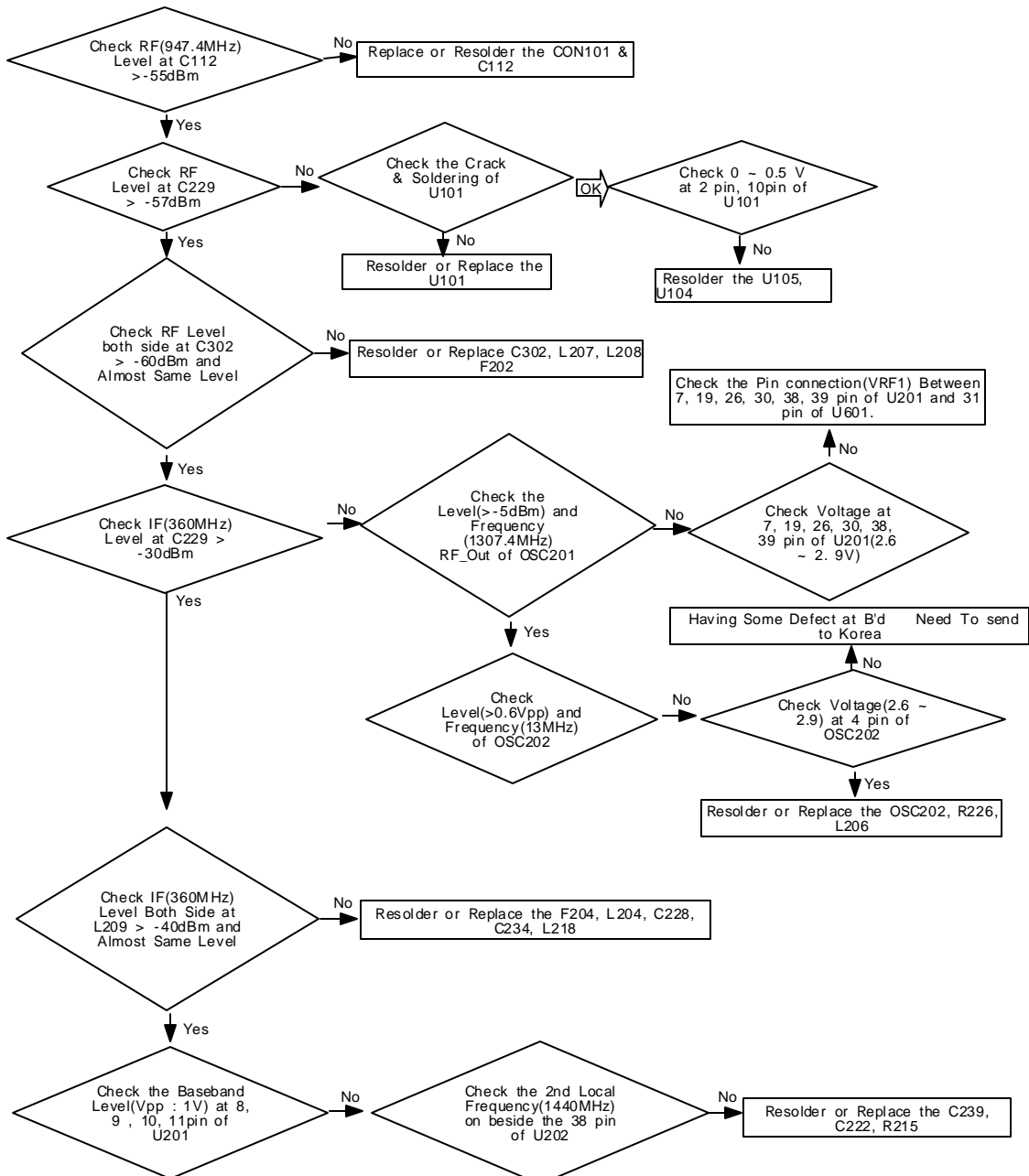

11. DCS Receiver

<Test Condition.>
 1. Phone Tool Inline Mode :
 - RF Mode : Rx Continuous.
 - ARFCN : Rx 711Ch.
 - Gain : Rx 88.
 2. Generator RF Level : -50dBm.
 3. Measure with Hewlett Packard 85024A active high frequency probe.
 Measured Value is dependent on Probe Measured Point of Component.

Flow Chart.(DCS : Rx Trouble Shooting)

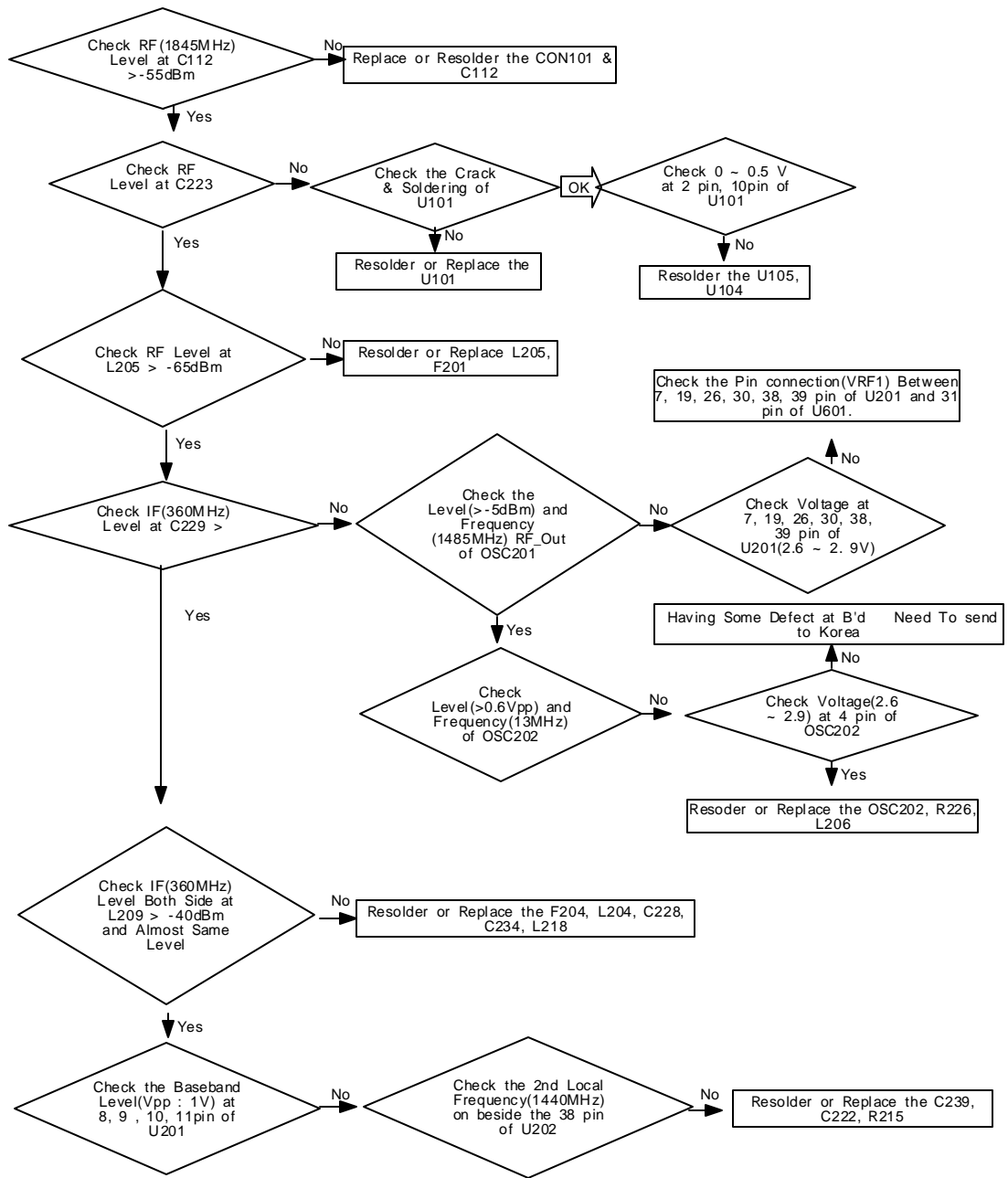

12. DCS transmitter

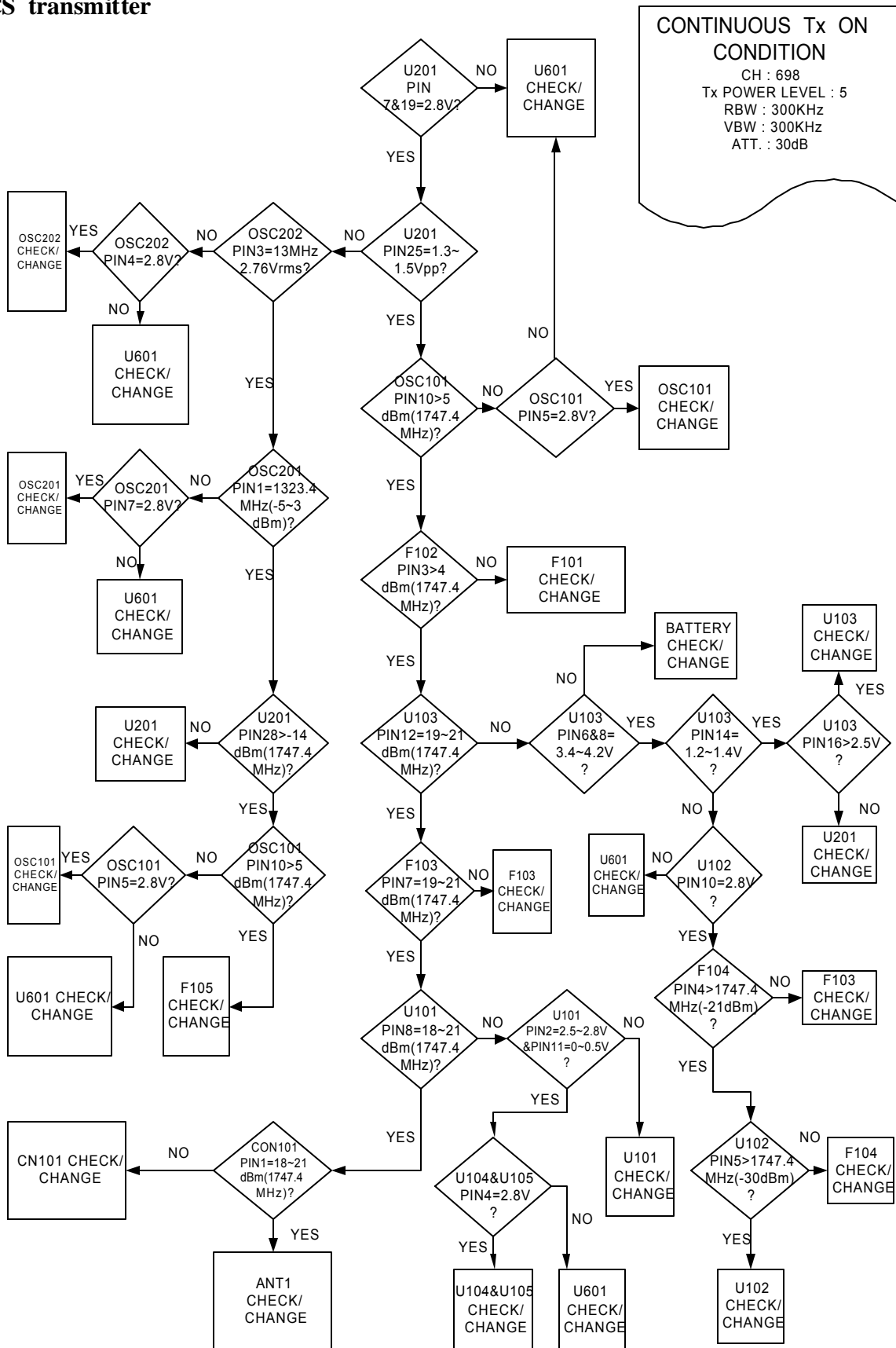

13. RF Circuit Diagram

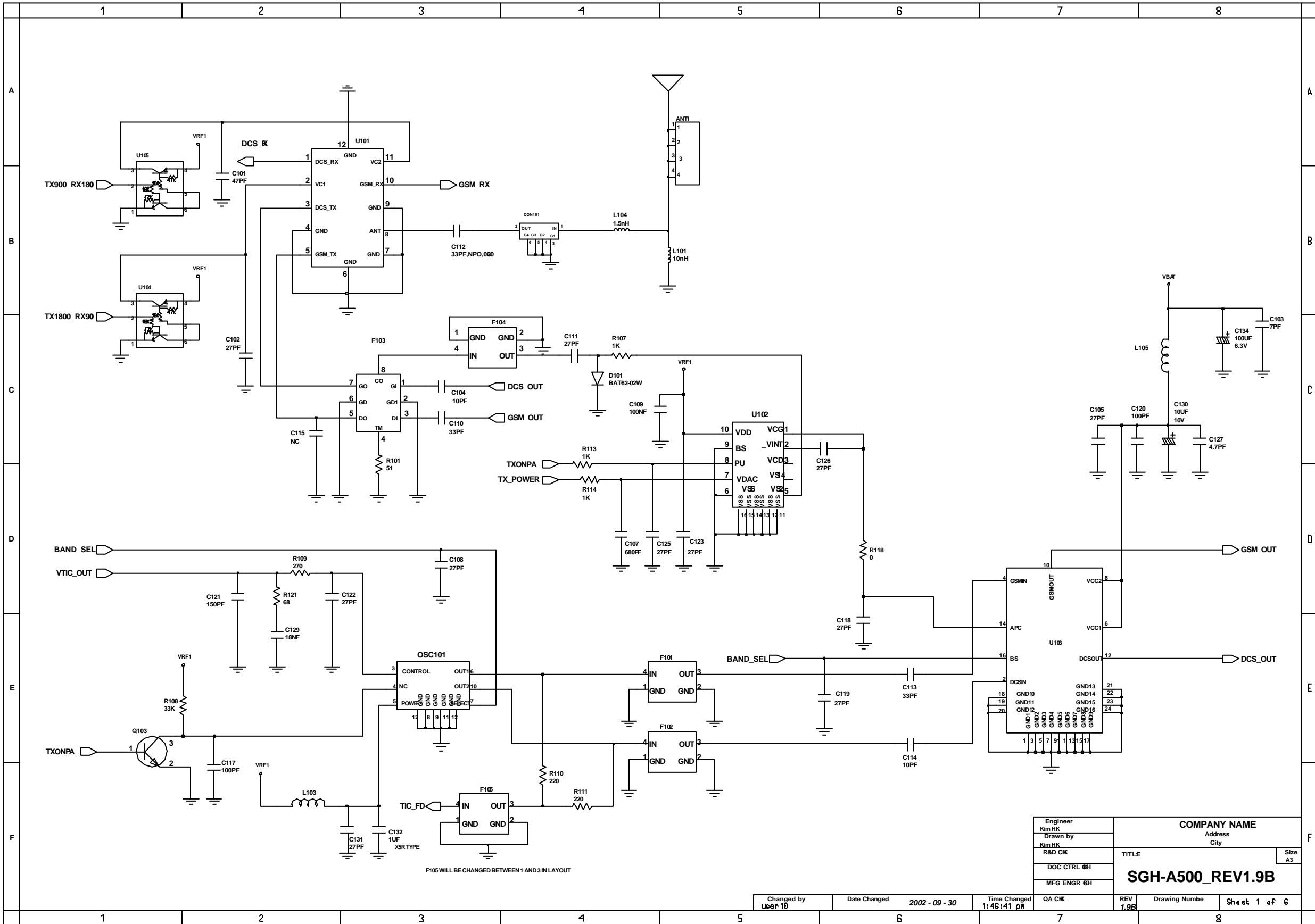

14. RF Trceiver Circuit Diagram

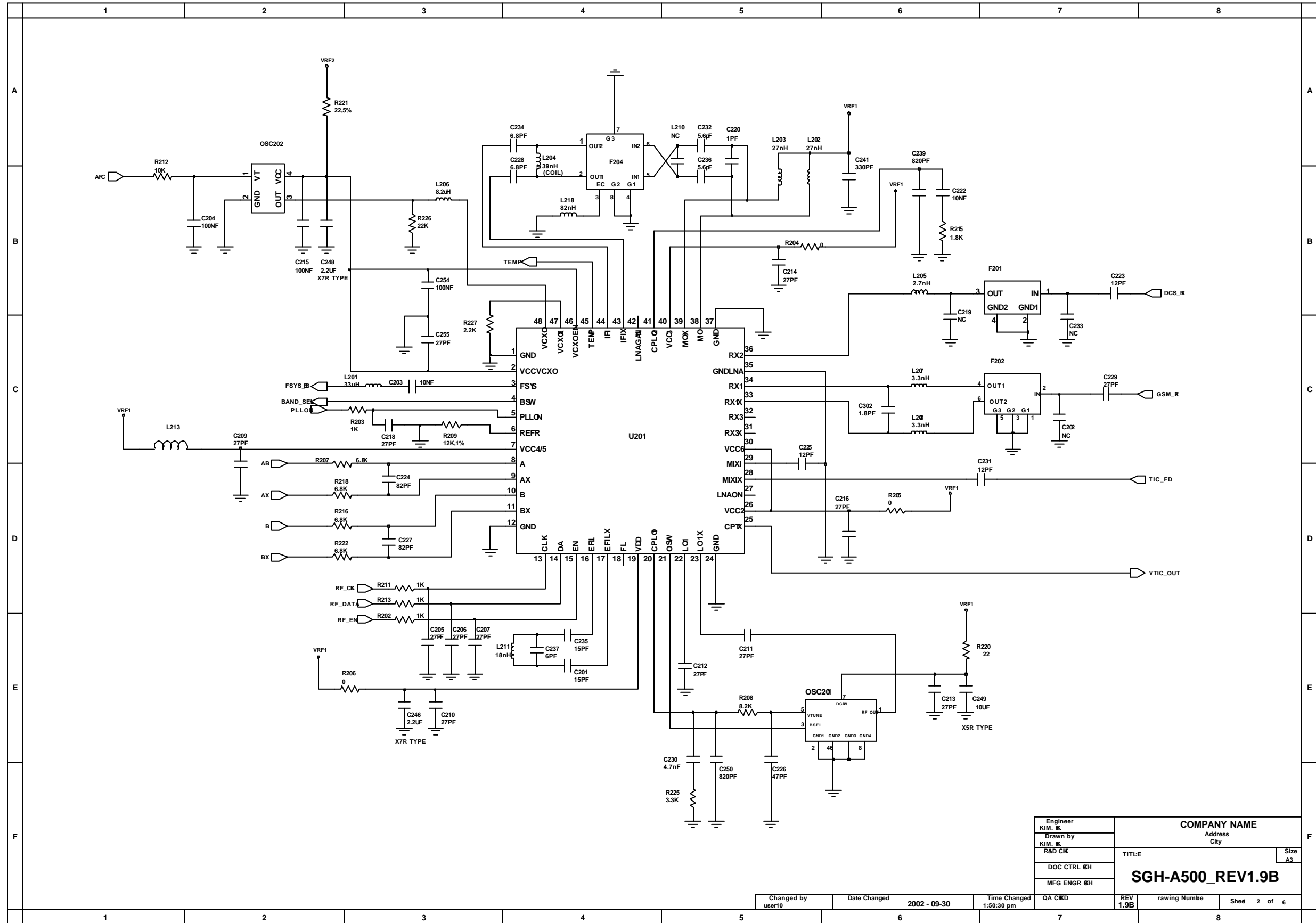

Engineer KIM_RK	COMPANY NAME	
Drawn by KIM_RK	Address City	
R&D CHK	TITLE	Size A3
DOC CTRL 6H	SGH-A500_REV1.9B	
MFG ENGR 6H		

Changed by user10	Date Changed 2002 - 09-30	Time Changed 1:50:30 pm	QA CKD	REV 1.9B	rawing Numbe	Shee 2 of 6
----------------------	------------------------------	----------------------------	--------	-------------	--------------	----------------

15. Memory & Connector Circuit Diagram

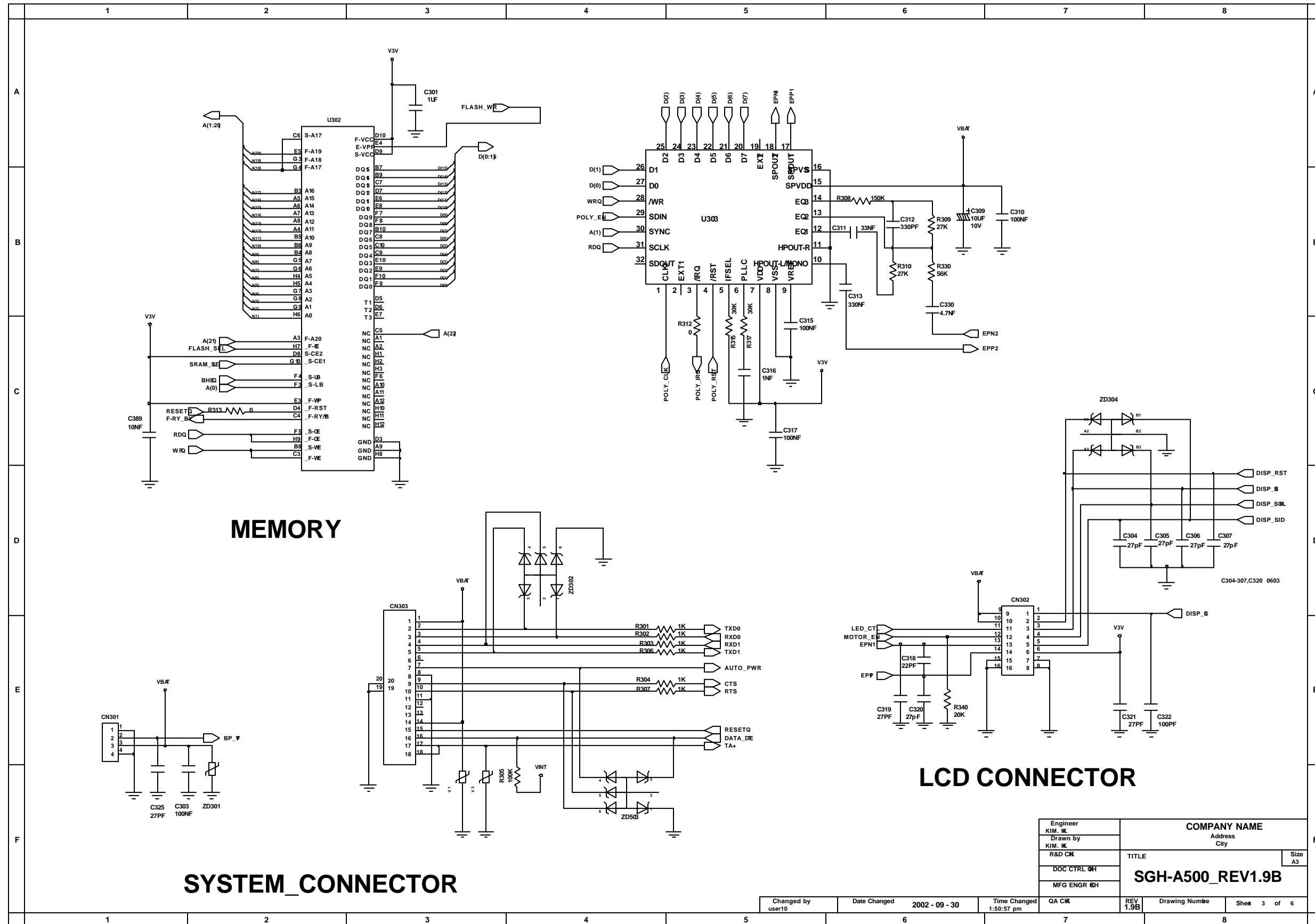

Engineer KIM. IK	COMPANY NAME	
Drawn by KIM. IK	Address	
R&D CK	City	
DOC CTRL 6H	TITLE	Size A3
MFG ENGR 6H	SGH-A500_REV1.9B	

Changed by user10	Date Changed 2002 - 09 - 30	Time Changed 1:50:57 pm	QA CHK	REV 1.9B	Drawing Number	Sheet 3 of 6
----------------------	--------------------------------	----------------------------	--------	-------------	----------------	-----------------

16. Baseband Processor Circuit Diagram

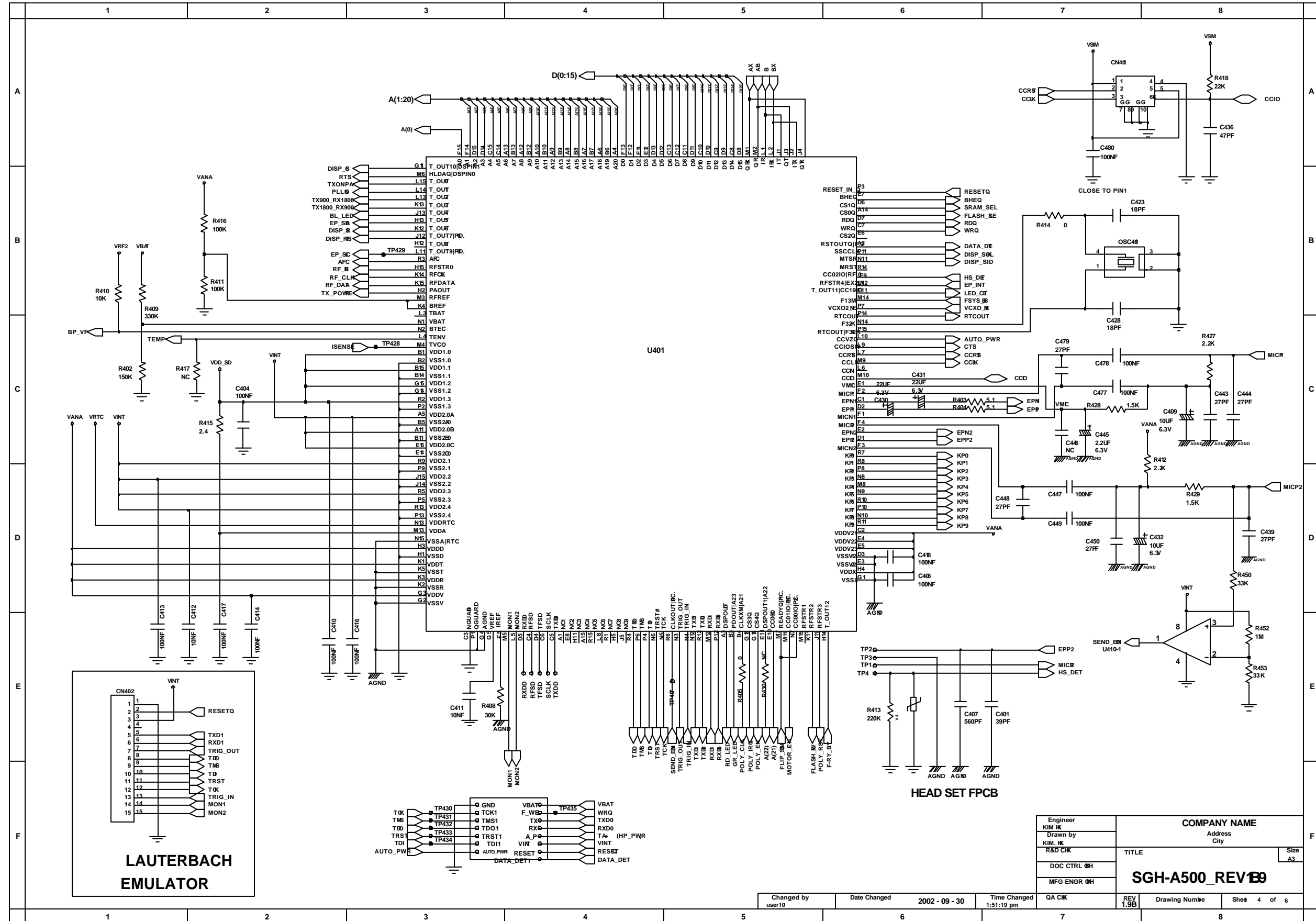

17. Key Matrix & LED Circuit Diagram

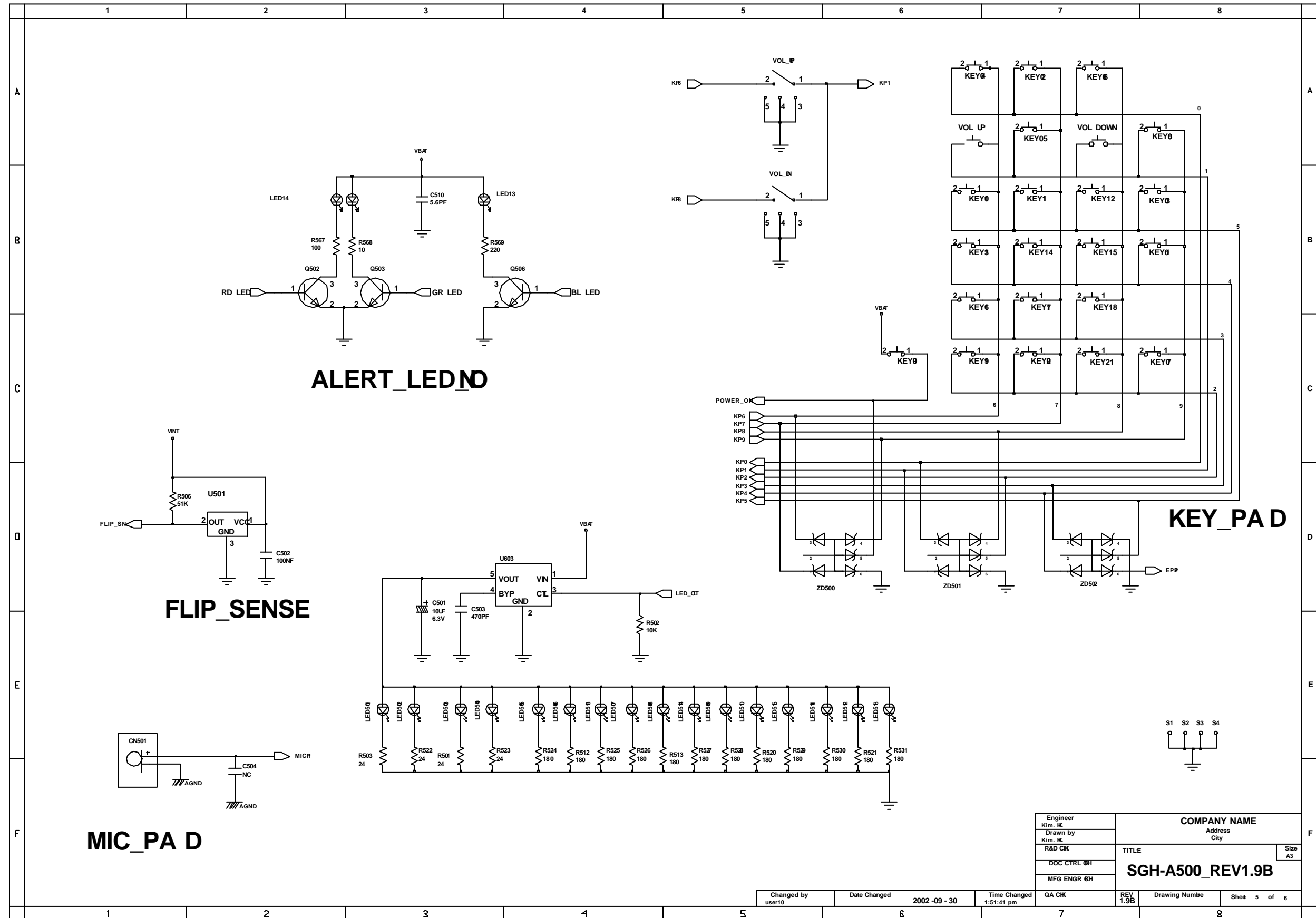

Engineer Kim. IK	COMPANY NAME	
Drawn by Kim. IK	Address	
R&D CHK	City	
DOC CTRL GH	TITLE	Size A3
MFG ENGR GH	SGH-A500_REV1.9B	

Changed by user10	Date Changed 2002-09-30	Time Changed 1:51:41 pm	QA CHK	REV 1.9B	Drawing Number	Sheet 5 of 6
----------------------	----------------------------	----------------------------	--------	-------------	----------------	-----------------

18. Power Management Circuit Diagram

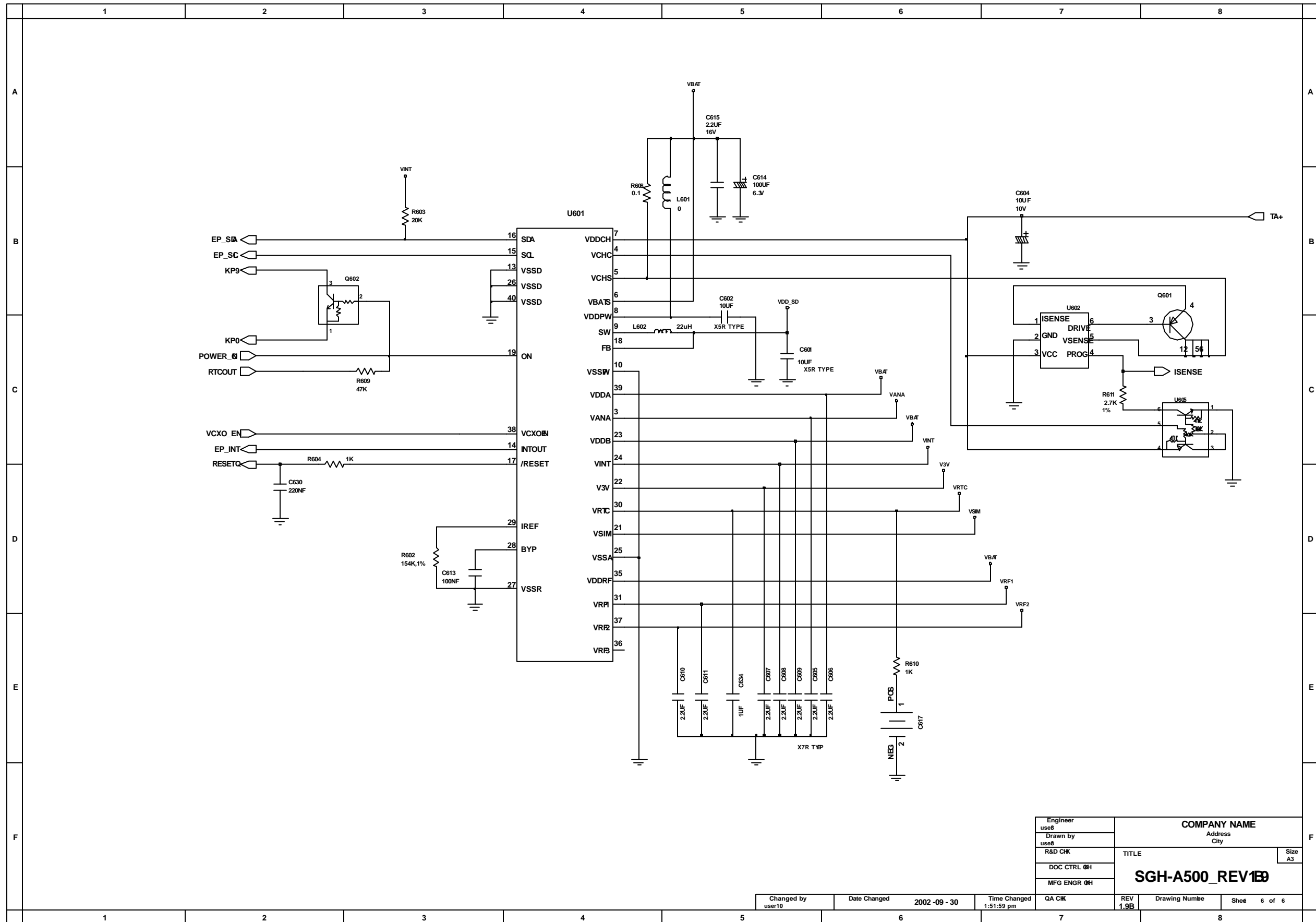



ELECTRONICS

Samsung Electronics Co.,Ltd. November. 2002
Printed in Korea.

Code No.: GH68-03059A
BASIC.