

4. PCB Diagrams

4-1 Main PCB Top Diagram

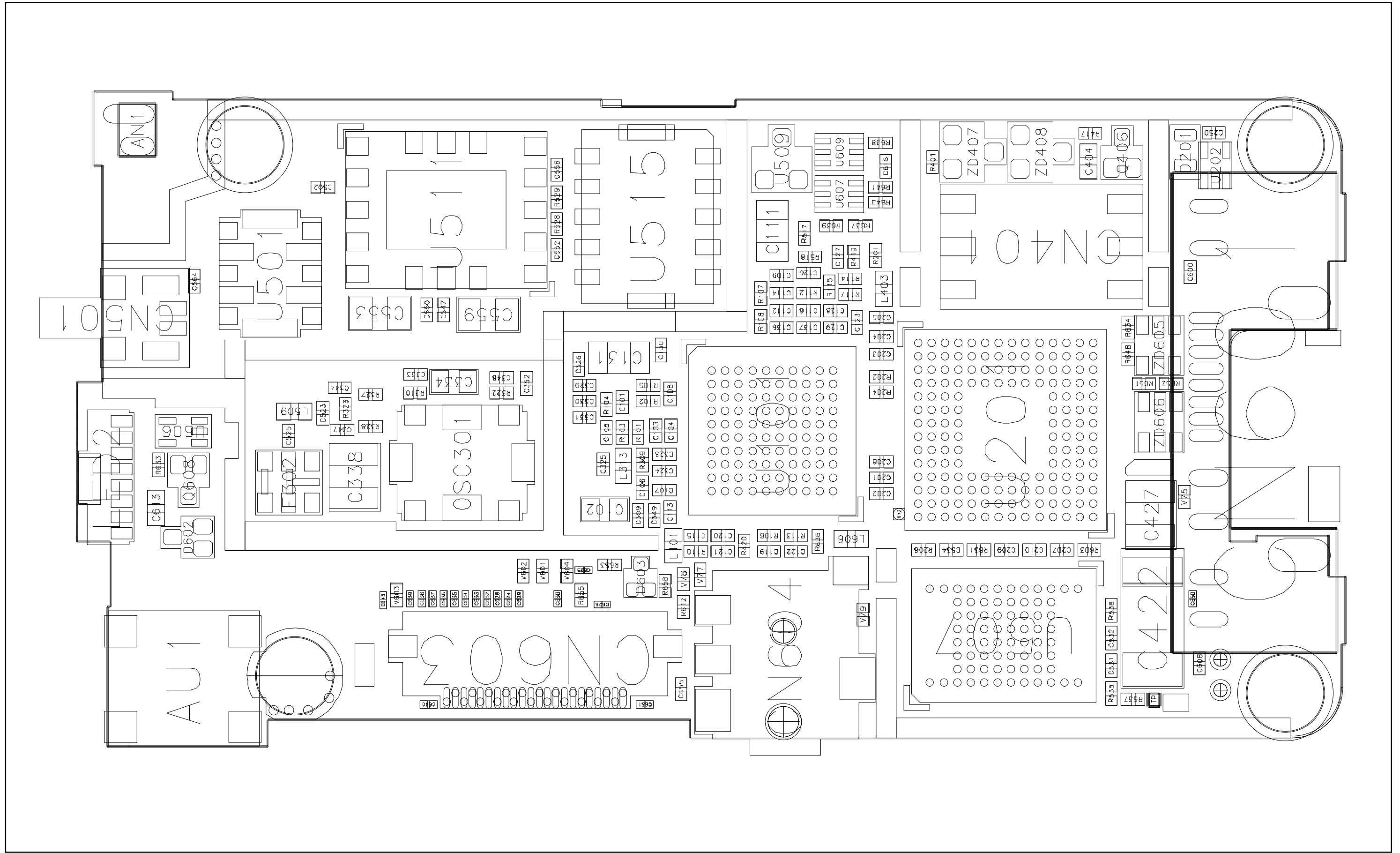

4-2 Main PCB Bottom Diagram

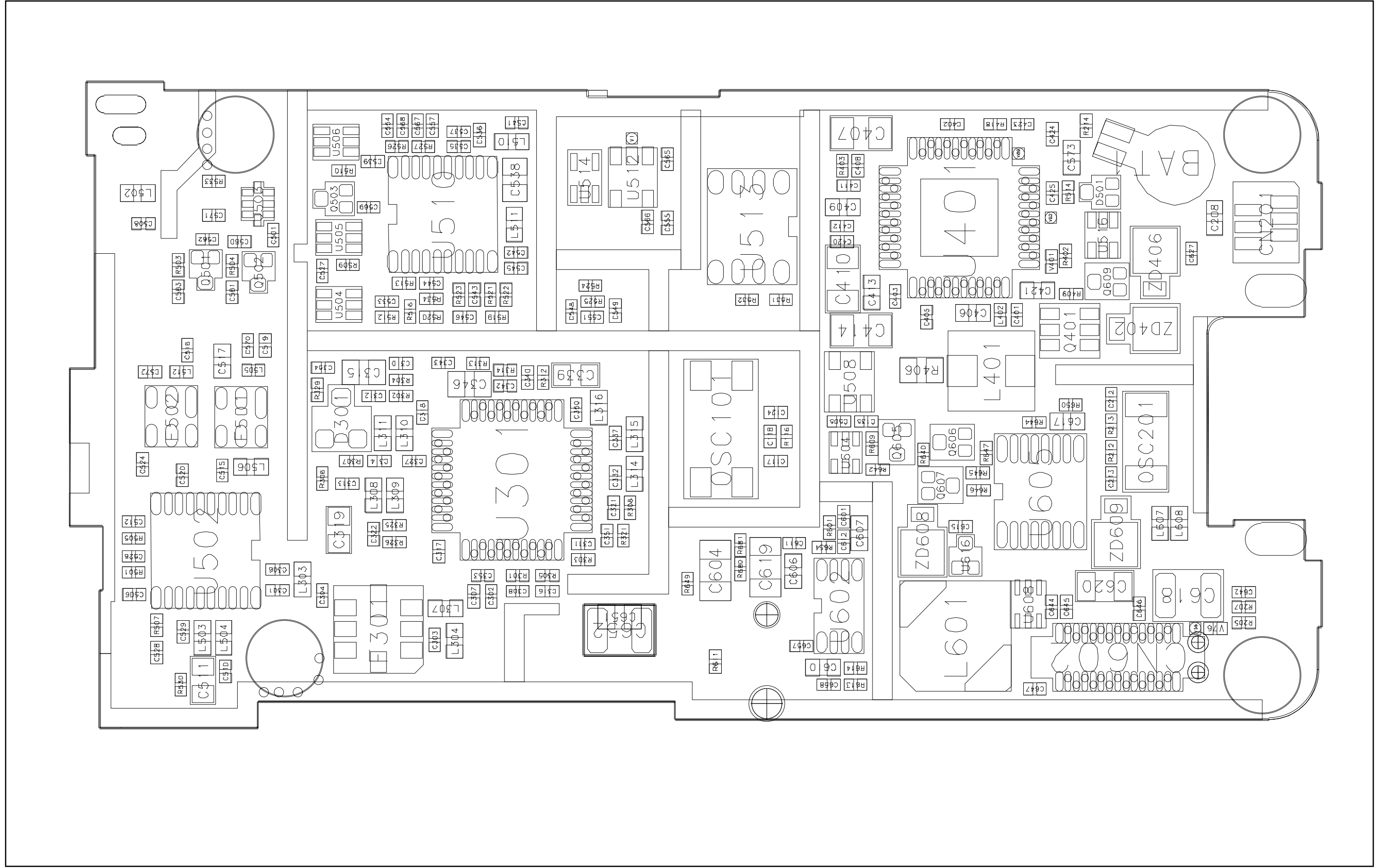

5. Circuit Diagrams

5-1 Integrated Analog Circuit Diagram

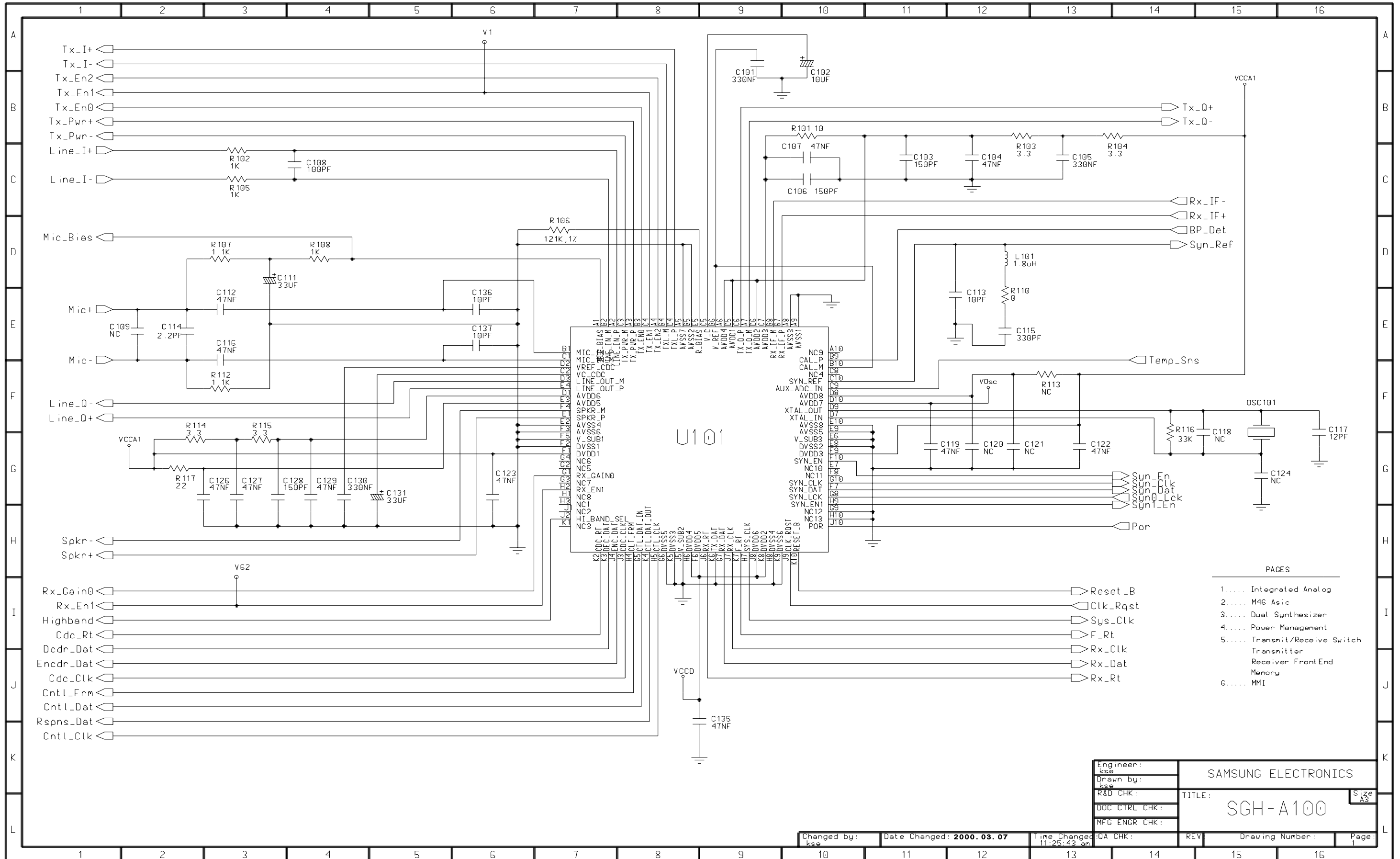

5-2 M46 Asic Circuit Diagram

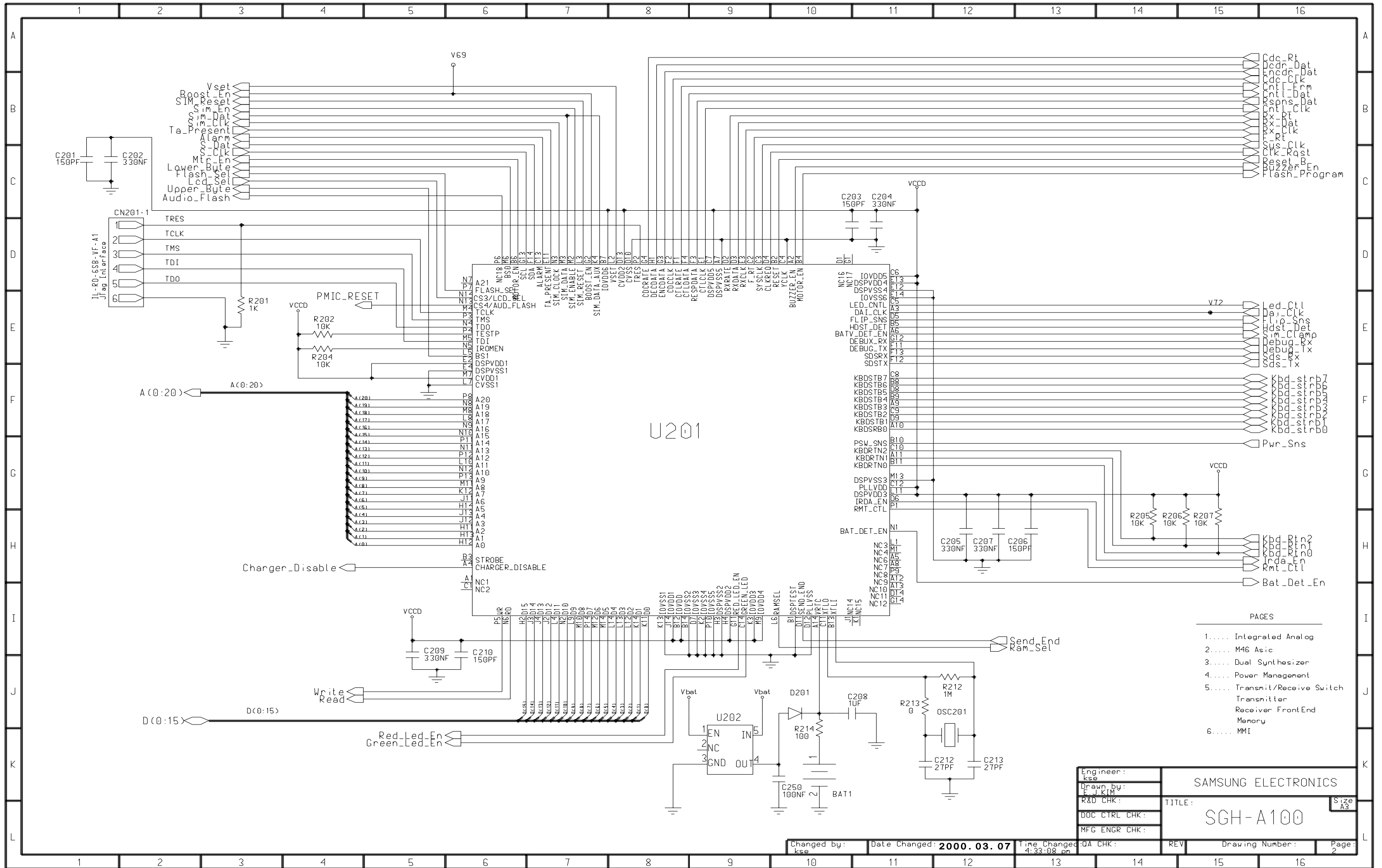

PAGES

- 1..... Integrated Analog
- 2..... M46 Asic
- 3..... Dual Synthesizer
- 4..... Power Management
- 5..... Transmit/Receive Switch Transmitter Receiver FrontEnd Memory
- 6..... MMI

Engineer : ksp	SAMSUNG ELECTRONICS
Drawn by : E.J.KIM	
R&D CHK :	
DOC CTRL CHK :	
MFG ENGR CHK :	
TITLE : SGH-A100	
Size : A3	

Changed by : ksp	Date Changed : 2000.03.07	Time Changed : 4:33:08 pm	QA CHK :	REV :	Drawing Number :	Page : 2
------------------	---------------------------	---------------------------	----------	-------	------------------	----------

5-3 Dual Synthesizer Circuit Diagram

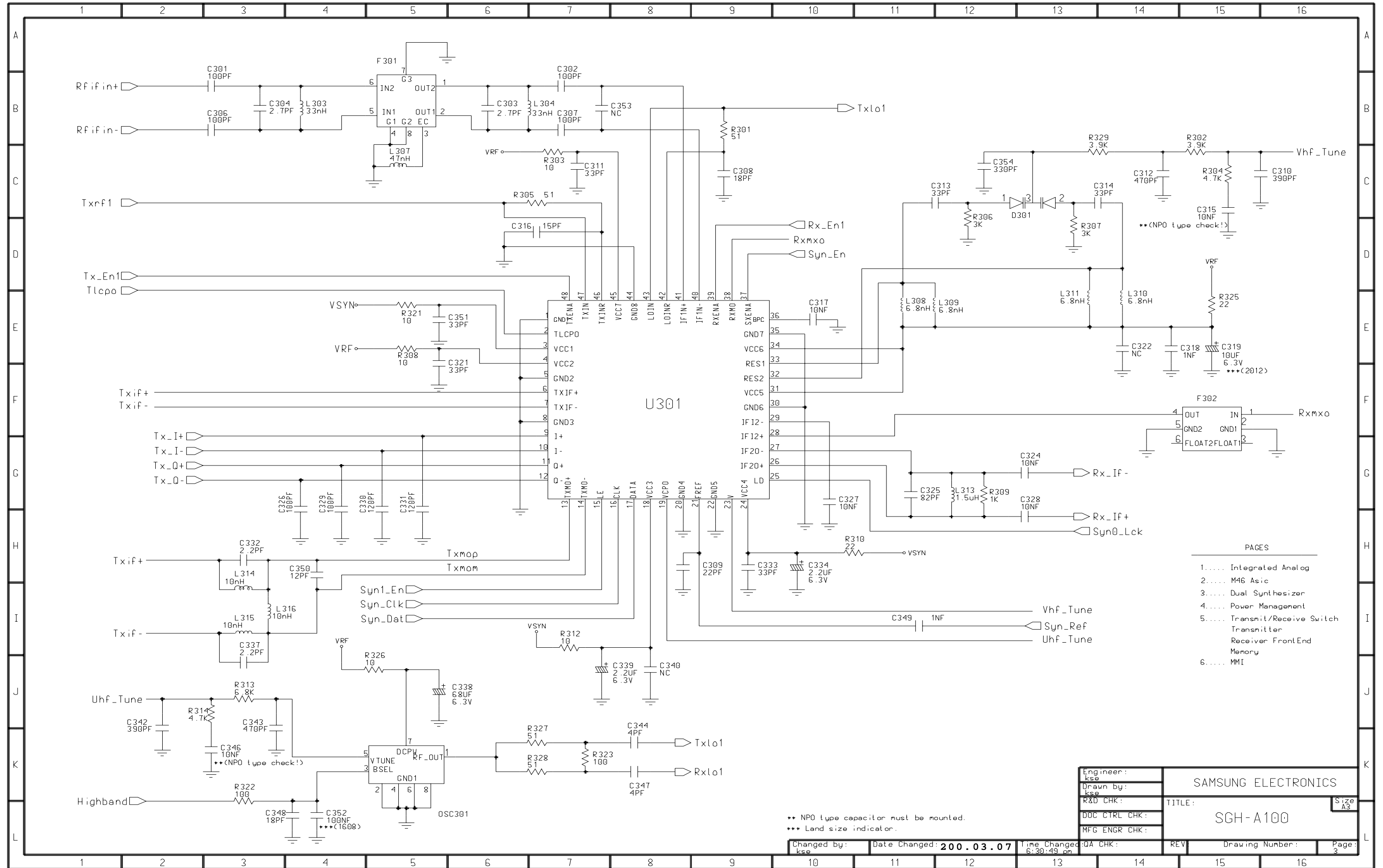

PAGES	
1.....	Integrated Analog
2.....	M46 Asic
3.....	Dual Synthesizer
4.....	Power Management
5.....	Transmit/Receive Switch Transmitter Receiver FrontEnd Memory
6.....	MMI

Engineer:	ksa	SAMSUNG ELECTRONICS
Drawn by:	ksa	
R&D CHK:		
DOC CTRL CHK:		
MFG ENGR CHK:		
TITLE:		SGH-A100
REV:		

** NPO type capacitor must be mounted.
*** Land size indicator.

Changed by:	Date Changed:	200.03.07	Time Changed:	6:30:49 on	QA CHK:	REV:	Drawing Number:	Page:
-------------	---------------	-----------	---------------	------------	---------	------	-----------------	-------

5-4 Power Management Circuit Diagram

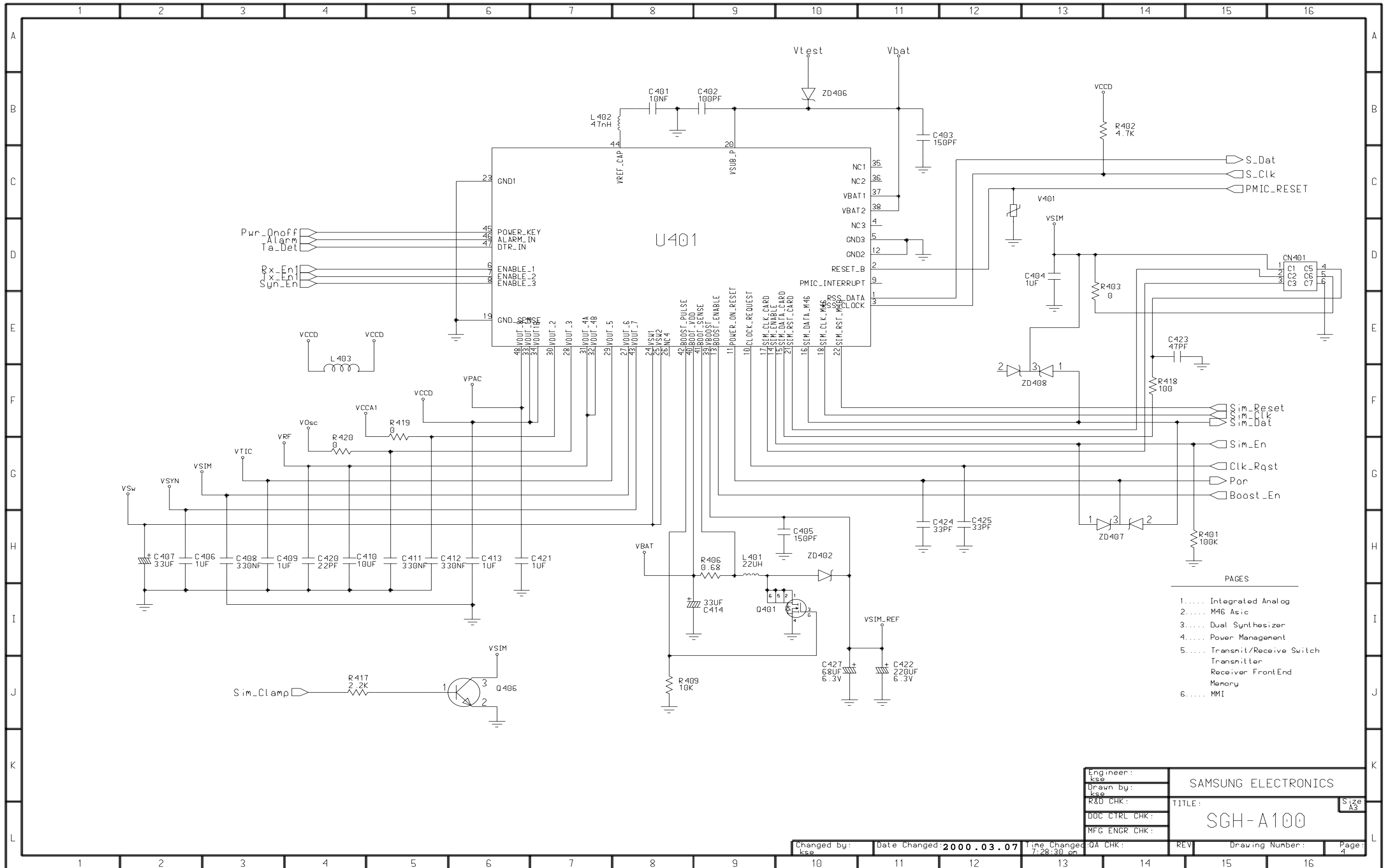

PAGES

1.....	Integrated Analog
2.....	M46 Asic
3.....	Dual Synthesizer
4.....	Power Management
5.....	Transmit/Receive Switch Transmitter Receiver FrontEnd Memory
6.....	MMI

Engineer: kso	SAMSUNG ELECTRONICS	
Drawn by: kso	TITLE: SGH-A100	
R&D CHK:	REV	Size A3
DOC CTRL CHK:	Drawing Number:	
MFG ENGR CHK:	Page: 4	

Changed by: kso Date Changed: 2000.03.07 Time Changed: 7:28:30 am

5-5 Transmit/Receive Switch, Transmitter, Receiver FrontEnd, Memory Circuit Diagram

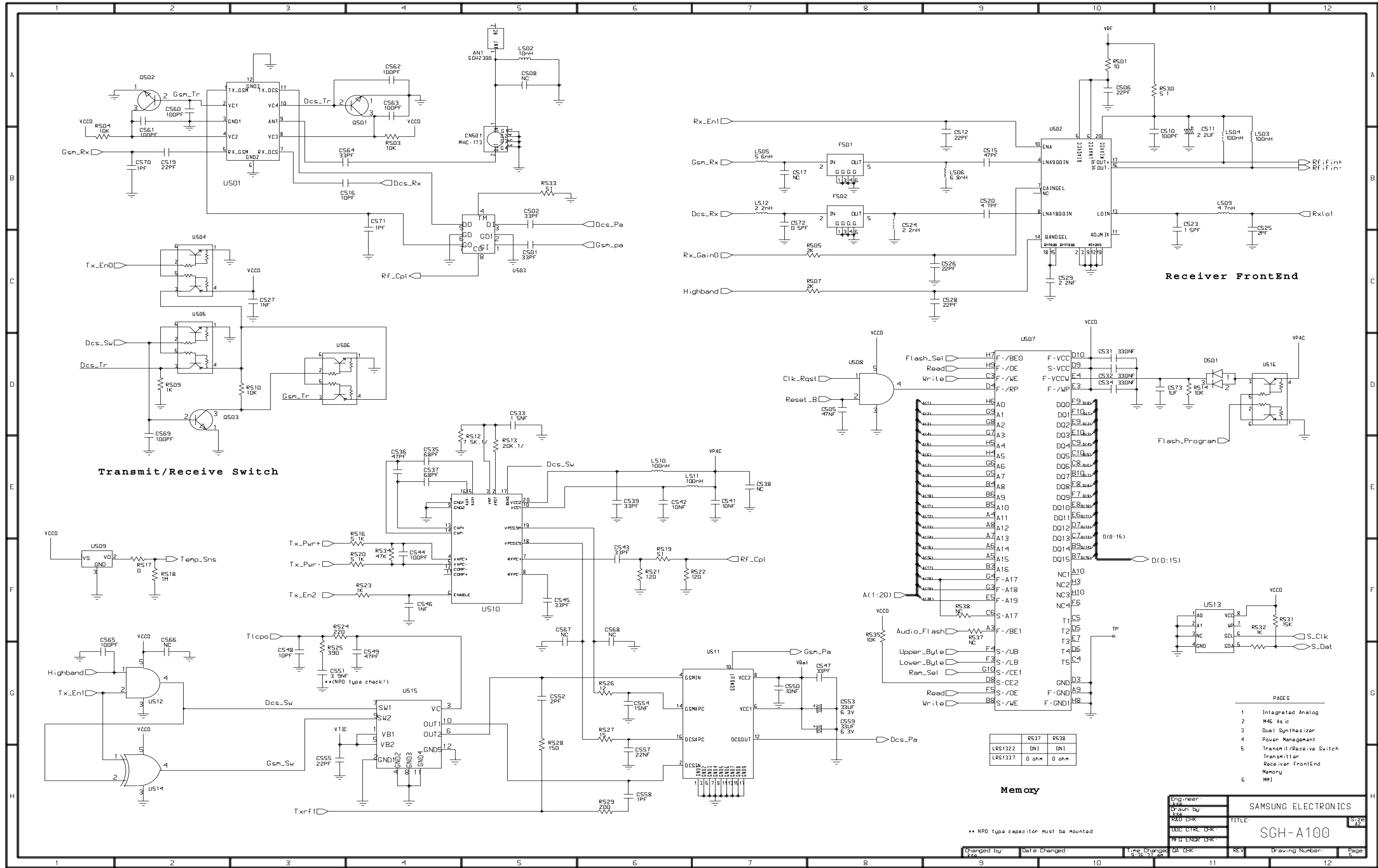

5-6 MMI Circuit Diagram

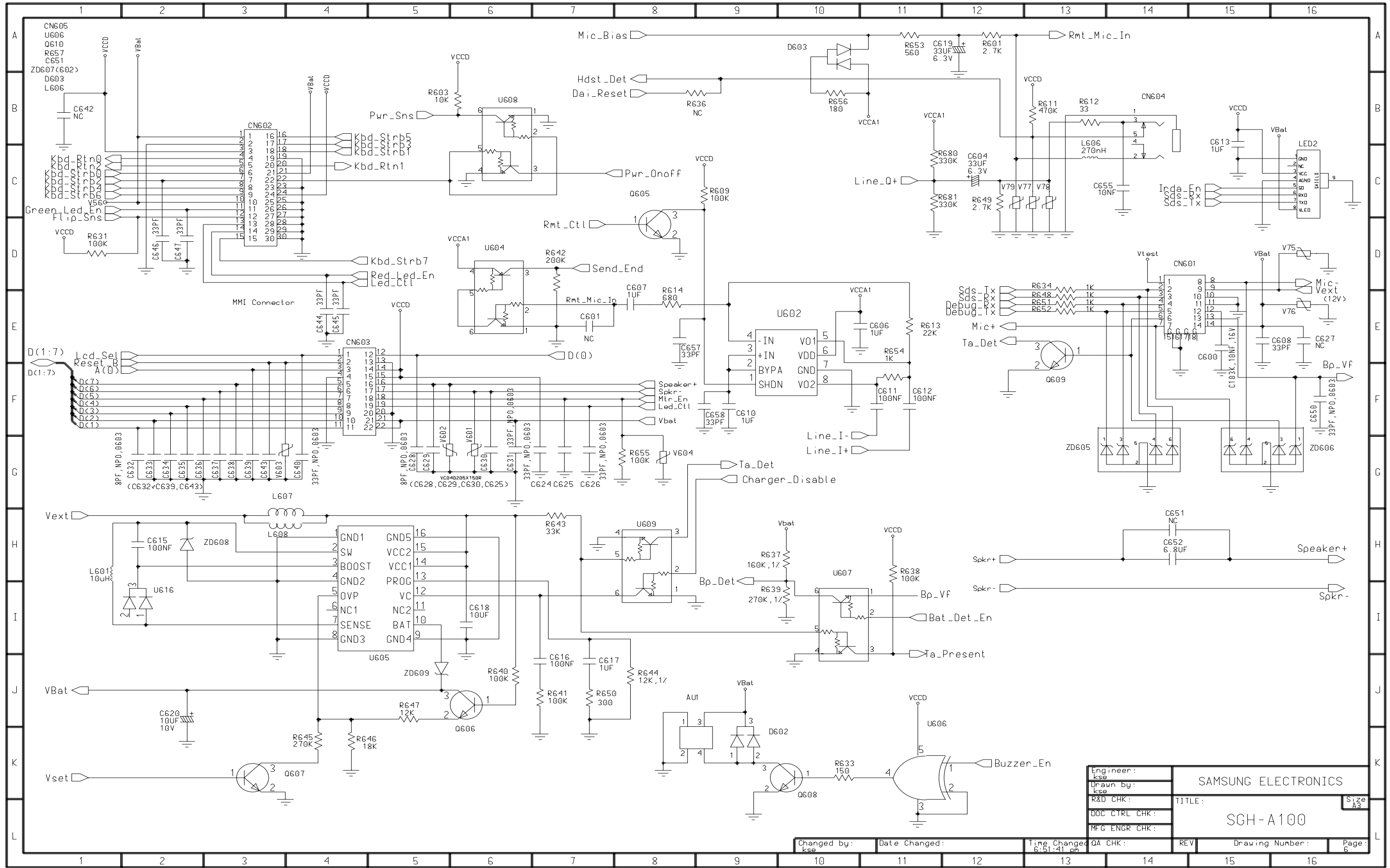

Engineer:	SAMSUNG ELECTRONICS	
Drawn by:	kse	
R&D CHK:	TITLE:	
DOC CTRL CHK:	SGH-A100	
MFG ENGR CHK:	Size A3	
Changed by:	Date Changed:	Time Changed: 6:51:41 pm
QA CHK:	REV:	Drawing Number:
		Page: 6