



DUAL BAND Mobile Cellular Phone SGH-2400

SERVICE *Manual*

DUAL BAND Mobile Cellular Phone



CONTENTS

1. Exploded Views and Parts List
2. Electrical Parts List
3. Block Diagrams
4. PCB Diagrams
5. Schematic Diagrams
6. Troubleshooting

1. General Description

1-1 GSM System

1-1-1 Calls

GSM® is an acronym for Global System for Mobile communications®, using TDMA for wide-area cellular operation. The GSM system consists of the sub-systems shown;

The Mobile Station (MS) talks to the Base Station System (BSS) via an RF air interface. The Base Station System (BSS) consists of Base Transceiver Station (BTS) and a Base Station Controller (BSC). The microwave link between BTS and BSC is called an Abis interface. Generally one BSC controls 20 to 30 BTSs, and a Mobile Switching Center (MSC) controlling the traffic among different cells would be reported back from a number of BSSs. A Visitor Location Register (VLR) will be allocated to one MSC to find the mobiles out of their home cell by listing them to VLR. The MSC would also be connected to the Home Location Register (HLR), the Authentication Center (AC) and the Equipment Identity Register (EIR) So the system verify that the users and equipment are legal subscriber.

1-1-2 Channels

Channels used in the GSM system can be divided into two classes - Logical and Physical channel. Physical channels can be described in terms of their frequency and time domain characteristics. They are the actual frequencies and timeslots the MS and BS transmits or receives on. The logical channels are mapped onto these physical channels logically. Any particular and instant, physical channels may be control or traffic channels, which determines the function of a physical channel at a particular point in time.

1-1-3 Airinterface of ARFCN (Absolute Radio Frequency Channel Number)

1	2	3	123	124
890.2 MHz								914.8 MHz	

1	2	3	123	124
935.2 MHz								959.8 MHz	

$$\text{P-GSM: TX: } F_l(n) = 890 + 0.2 * n \quad (1 \leq n \leq 124)$$

$$\text{RX: } F_u(n) = F_l(n) + 45$$

< Fig. 1 ARFCN Diagram >

1-1-4 GSM TDMA Timeslots, Frames, and Multiframe

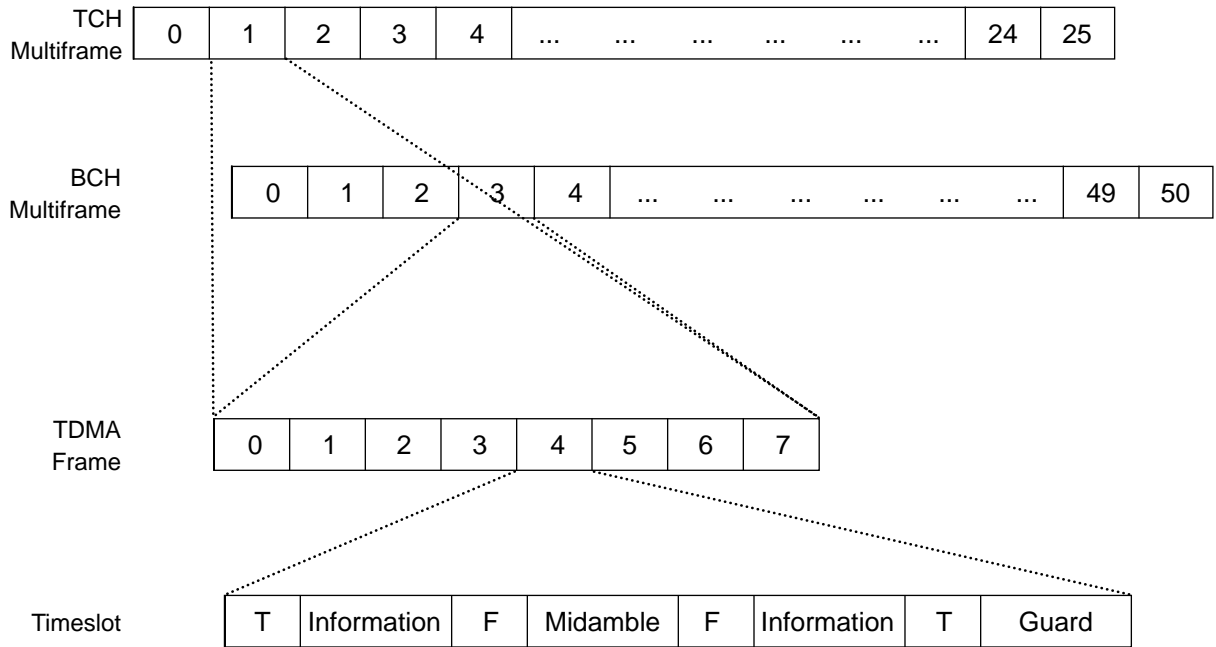

< Fig. 2 Concept of Frames and Timeslots >

1-1-5 Logical Channel

TCH (Traffic CH) is used mainly for transferring the speech information, and the BCH (Broadcast CH) is related to control information. The major function of BCH is transferring information on the downlink for MS synchronization, identification, paging, and control. BCH is always radiated from every cell and the MS tries to find the BCH which has highest level soon after turned on. The organization of BCH is shown below; FCCH (Frequency Correction Channel), SCH (Synchronization Channel), and BCCH (Broadcast Control Channel). CCCH (Common Control Channel) will play a role like a message board, and is divided into two control channels - PCH (Paging Channel) and AGCH (Access Grant Channel). SACCH (Slow Associated Control Channel) exists every 12 frames, controlling and controlling the TX power level and timing advance of MS, transferring cell information to MS on downlink, transferring the information about RX level, Quality, and RX level of adjacent cell on uplink. FACCH (Fast Associated Control Channel) steals and changes the TCH when needing a Handover. SDCCH (Stand-alone Dedicated Control Channel) and RACH (Random Access Channel) operate during the call setup procedure.

1-2 GSM HHP Feature

1-2-1 Main Set (HHP)

The main set is a microprocessor (KERNEL5)-controlled, full duplex radiotelephone system that provides the user with GSM cellular service through cell sites linked to control centers. It also provides functions related to frequency control, power control, and many user-convenience features.

1-2-2 Desktop Charger

The DTC is designed to charge batteries from commercial mains. The charger has two battery receptacles. The forward one is for rapid charging, and the rear for normal charging.

1-2-3 Travel Adaptor

The travel adaptor is designed to operate the main set by supplying power to directly, while charging batteries from commercial mains.

1-2-4 Cigar Lighter Adaptor

A cigar lighter adaptor is used to operate the main set and charge the battery from a 12 volt vehicular electrical system.

1-2-5 Hands Free Car Kit

The Hands Free kit provides unlimited talk time, as power is supplied by the vehicular electrical system, and improved receiving and transmitting due to the external antenna. The Hands Free car kit adapts an external speaker, a hands-free microphone, a bracket, and a cradle for mounting the main set. ®Hands Free® means user can have a conversation without holding the phone by hand.

MEMO

3. Specification

3-1 General Specification

3-1-1 Frequency Range

- Transmit (Uplink): 890 ~ 915 MHz
- Receive (Downlink): 935 ~ 960 MHz

3-1-2 Channel Spacing : 200 kHz

3-1-3 Number of Channels: 124

3-1-4 Frequency Spacing: 45 MHz

3-1-5 Modulation Data Rate

- 270.833 kbits/sec

3-1-6 Frame Period: 4.615 msec

3-1-7 Timeslot Period: 576.9 μ sec

3-1-8 Modulation Type: 0.3 GMSK

3-1-9 MS Max Power: 2 W (33 dBm)

3-1-10 MS Min Power: 0.3 W (5 dBm)

3-1-11 Voice Coder Bit Rate: 13 kbits/sec

3-1-12 Input / Output Impedance : 50 Ω

3-1-13 VCO Frequency

- TX VCO : 890 ~ 915 MHz,
- UHF VCO : 1160 ~ 1185 MHz
- VHF VCO : 540 MHz

3-1-14 IF

- 1st RX IF: 225 MHz
- 2nd RX IF: 45 MHz
- 1st TX IF: 270 MHz

3-1-15 VCTCXO Frequency

- 13 MHz (± 5 PPM)

3-1-16 Operating Temperature

- Main : Nominal: +15 $^{\circ}$ C ~ +35 $^{\circ}$ C
Extreme: -10 $^{\circ}$ C (spec) ~ +55 $^{\circ}$ C
- TA : Nominal: +15 $^{\circ}$ C ~ +35 $^{\circ}$ C
Extreme: -20 $^{\circ}$ C ~ +55 $^{\circ}$ C

3-1-17 Operating Voltage

- High Voltage: 4.1 V
- Nominal Voltage: 3.7 V
- Low Voltage: 3.4 V

3-2 Transmitter Specification

3-2-1 Power

Power Control Level	Peak Power (dBm)	Norminal (dB)	Extreme (dB)
5	33	±2 dB	±2.5 dB
6	31	±3 dB	±4 dB
7	29	±3 dB	±4 dB
8	27	±3 dB	±4 dB
9	25	±3 dB	±4 dB
10	23	±3 dB	±4 dB
11	21	±3 dB	±4 dB
12	19	±3 dB	±4 dB
13	17	±3 dB	±4 dB
14	15	±3 dB	±4 dB
15	13	±3 dB	±4 dB
16	11	±5 dB	±6 dB
17	9	±5 dB	±6 dB
18	7	±5 dB	±6 dB
19	5	±5 dB	±6 dB

The power-time template requirements for mobile stations also apply to base stations. The only difference is that, in the base station case, no short burst (random access) exists. To measure the template, the base station has to be operated in its *bursting mode*. This test cannot be performed on the base channel, since a base station has to transmit continuously in all time slots. In most cases, an additional channel besides the base channel has to be activated or the transmitter under test is not considered to be configured as a base channel transmitter. The average peak power from the previous part of the test is used as a reference. The time reference is provided by the training sequence in the middle of the burst. The template has to meet the requirements of Fig. 6. Again, the noise level of -70 dBc is dependent on the actual transmitted power level. If this level is below -36 dBm, the absolute level applies. The template is usually evaluated along with the peak power level.

3-2-2 Power Ramping Time Level

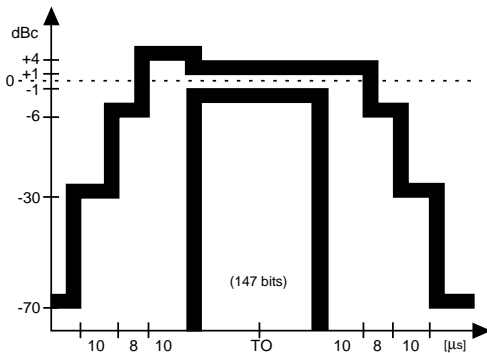

< Fig. 6 Power-Time Template >

3-2-3 IF Filter

- 270 MHz LC Filter

3-2-4 TX SAW Filter

- Spurious signal attenuating : ≤-70 dBc
 - Wide Bandwidth to make plane Group delay characteristic

3-2-5 Power Amplifier

- Total Efficiency: 40~45 % at Pin=1mW,
 V_{DD}=3.6 V, Pout=3.2 W

3-3 Synthesizer Specification

3-3-1 General Specification

- Frequency Hopping : 1 Channel to $< 3^\circ$ rms in < 500 mS
- Phase Noise: $< 3^\circ$ RMS

3-3-2 IF Synthesiser

- Synthesizer Frequency: 540 MHz
- Output Signal Drive Level: -10 dB
- 2nd IF LO Output Frequency FIR: 45 MHz

3-3-3 FIR Output

- 1st IF: 225 MHz
- 2nd IF: 45 MHz
- FIR Frequency: 45 MHz
- FIR Level: -17 dBm

3-3-4 Phase Noise Specification

Offset (kHz)	Phase Noise (dBc/Hz)
± 200	< -75
± 250	< -78
± 400	< -105
> 600	< -105
> 1200	< -105
> 1800	< -113
> 3000	< -115
> 6000	< -121
> 10.0 MHz	< -124
> 20.0 MHz	< -129
> 30.0 MHz	< -134

3-4 Receiver Specification

3-4-1 Front-end Specification

- Input Frequency range: 935 MHz ~ 960 MHz
- Gain: 18 dB
- If Frequency range: 540 MHz
- Input Impedance: 150 Ω
- Output Load: 1 k Ω
- Overall Sensitivity: -106 dBm for 9 dB S/N in 180 kHz

3-4-2 Sensitivity

- Reference Sensitivity Level: -102 dBm
- Channel Width : 180 kHz
- Input Thermal Noise: -121.4 dBm/Hz
- Output S/N: > 9 dB
- Noise Figure: < 7 dB

3-4-3 Intermodulation

- Input Useful Signal: -99 dBm
- Interferer: -49 dBm at ± 800 kHz and 1600 kHz

3-4-4 Selectivity

Signal	Type	Level
Useful Signal	GMSK	- 82 dBm
Cochannel	GMSK	- 9 dBc
± 200 kHz	GMSK	+ 9 dBc
± 400 kHz	GMSK	+ 41 dBc
± 600 kHz	GMSK	+ 49 dBc

MEMO

2. Circuit Description

2-1 RF Part

2-1-1 Frequency Generator

The 13MHz reference clock (VCTCXO) drives the logic and RF part. The 13 MHz reference is controlled by the logic (10bits DAC minimum) and is kept to a frequency error less than ± 0.1 ppm after synchronization with the GSM network.

A 540 MHz oscillator is divided by 2 to generate a fixed 270 MHz VHF LO used in the TX I,Q modulator and mixed by 270 MHz. The UHF LO for the first RX down conversion and the TX offset mixing works in superheterodyne mode to reduce the relative bandwidth and to be able to work at a frequency greater than 1 GHz.

2-1-2 Transmitter

The baseband GSM chipset (Kernel5) generates I and Q baseband signals for the transmit vector modulator. The modulator provides more than 40dBc of carrier and unwanted side-band rejection and produces GMSK modulated signal, the 'reference' signal at 270 MHz which passes to the offset phase-locked loop block (OPLL). The OPLL consists of a down-converter, phase detector, loop filter and transmit VCO operating at the final RF output frequency. The down converter mixes the UHF LO (eg. 1172 MHz) with the transmit VCO signal to generate a 'feedback' signal at 270 MHz. The 'feedback' signal passes via a limiter to one port of the phase detector. The GMSK 'reference' signal from the vector modulator passes via a second limiter to the other input port of the phase detector. The phase detector generates an error current proportional to the phase difference between the 'feedback' signal from the down-converter and the 'reference' signal from the vector modulator. This error current is filtered by a second order low-pass filter to generate an output voltage which depends on the GMSK modulation and the desired channel frequency. This voltage controls the transmit VCO such that the VCO output signal, centered on the correct RF channel, is frequency modulated with the original GMSK data. The centre frequency of the transmit VCO is offset from the UHF LO frequency by 270 MHz. The OPLL acts as a tracking narrowband band pass filter tuned to the desired channel frequency. This reduces the wideband noise floor of the modulation and up-conversion process and provides significant filtering of spurious products. The OPLL architecture results in a low-noise GMSK modulated signal at 902 MHz with very low spurious content.

The RF GMSK output from the transmit VCO is fed via TX SAW filter to the RF power amplifier. The peak output power and the profile of the transmitted burst are controlled by means of a closed feedback loop. The RF output from the PA is sampled with a directional coupler. The sampled signal passes to an RF detector diode whose output voltage is dependent on the incident RF level. This 'feedback' voltage passes to the inverting input of the loop integrator. A 'reference' signal is generated within the baseband section under control of the layer 1 software. The loop maintains zero difference between the 'feedback' signal and the 'reference' signal. In this way, the amplitude and shape of the transmitted RF burst may be controlled by the baseband processor. In particular, the rise and fall profiles can be controlled to meet the stringent power/time templates and switching transient requirements of GSM 05.05.

The RF output passes to the antenna connector via an integrated TX/RX switch and lowpass filter to attenuate the harmonics generated by the power amplifier.

2-1-3 Receiver

The incoming RF signal passes through the integrated lowpass filter and TX/RX switch. This is followed by a 947 MHz SAW Band Pass Filter and a bipolar low-noise amplifier (LNA). The HD155101BF includes an active bias circuit which stabilizes the DC operating point of the LNA. The RF signal passes via a second RF SAW filter to the first receive mixer. This mixer is implemented as a Gilbert cell within the HD155101BF. The incoming signal at 947 MHz mixes with the UHF LO at 1172 MHz to generate a 225 MHz IF signal. The IF signal passes from the mixer output via a 225 MHz IF SAW filter to the first IF amplifier. A further internal Gilbert cell mixes the 225 MHz IF signal down to the 45 MHz second IF. The 45 MHz output from the second mixer is filtered and passes to the AGC amplifier. The gain of the AGC amplifier is set by a DC control voltage supplied by the baseband. The usable control range is in excess of 80dB. Finally, the AGC output signal at 45 MHz passes to the demodulator and is mixed down to DC to generate I and Q baseband signals. The baseband signals pass via baseband filter to the baseband A/D converters. The remainder of the channel filtering is performed by the baseband chipset.

2-2 Baseband Part

2-2-1 General Block Diagram

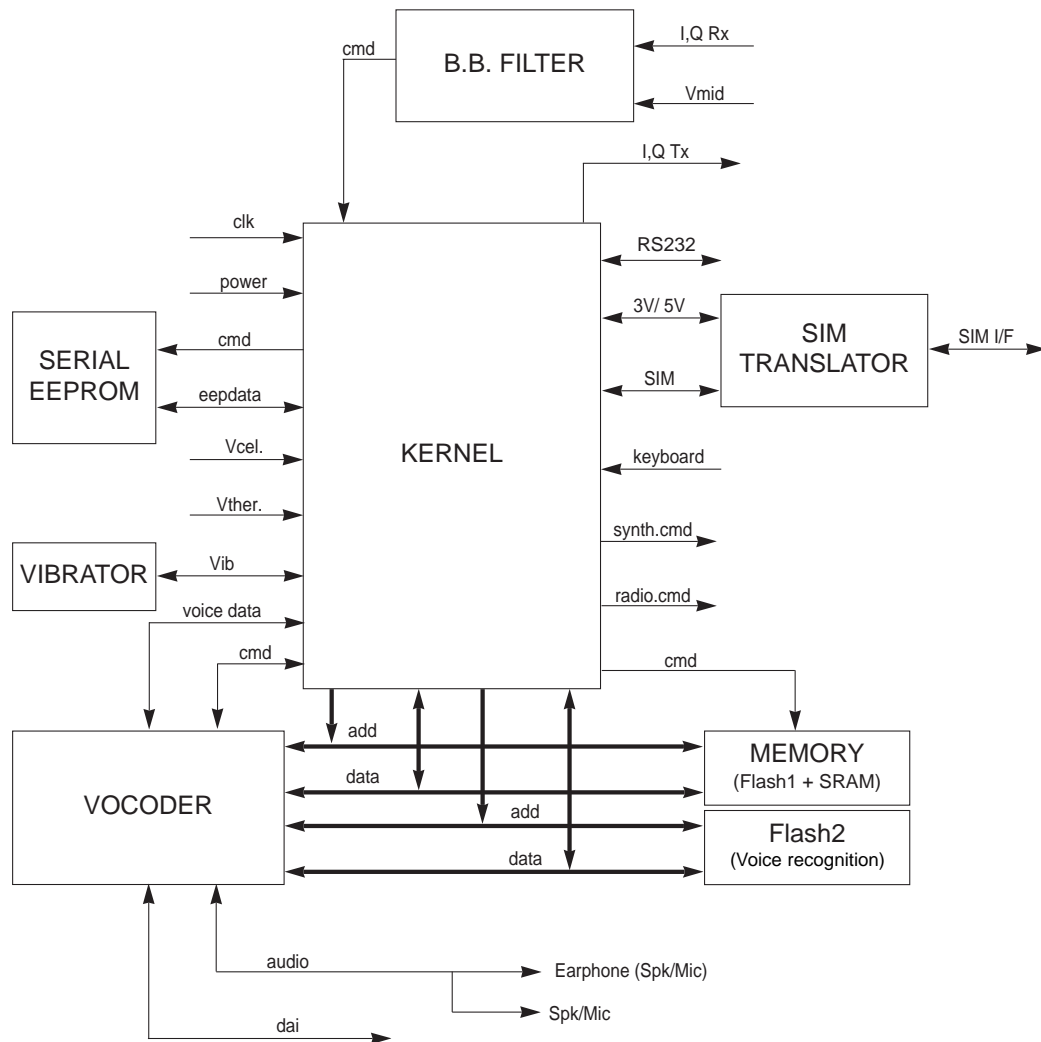

< Fig. 3 Baseband Block Diagram >

2-2-2 ROM1 & SRAM

8M (X16) Flash ROM and 2M (X8) bit SRAM are used. Two devices are merged in one package. This device is a combination memory organized as 524, 288 x 16 bit flash memory and 262, 144 x 8 bit static RAM in one package.

2-2-3 ROM2

A 8M (X16) bit Flash Memory is used for the voice recognition and voice memory. This device is an 8, 388, 608 bit flash memory with batch chip erasing, sector erasing, and byte and word writing using a single 3V power supply.

2-2-4 EEPROM

The kernel requires some external non-volatile memory to store various system parameters, such as RF control calibrations, extra dial stores etc. A 64 K (65, 536) bit device is used. This device is internally organized 8192 x 8. This device features a serial interface and software protocol allowing, operation on a simple, two wire bus.

2-3 SIM

2-3-1 SIM Interface

An interface is provided to a serial port controlling the SIM interface. It can support 5V and 3V SIM interface. The hardware interface consists of SIMVCC, SIMdata I/O, SIMclk output, SIMRST output, and SIMPRES input. The interface is controlled through TX Data, RX Data, control, and status registers. Transmit and receive data may use a 256 byte buffer or be exchanged through single byte registers. SIMVCC may be used to control the power supply to the SIM card.

2-4 POWER MANAGEMENT

2-4-1 DC/DC Converter

Our 1 cell Li-ion battery solution requires a up-converting DC/DC conversion circuit for efficiency improvement. The device is a PWM Step-up DC/DC converter IC. Specification is as below;

- V_{in} : 2.75 V ~ 4.2 V
- V_{out} : 3.3 V ~ 4.1 V
- Ripple: less than 50 mVpp
- Efficiency: typ. 85 % (up to 96%)

2-4-2 Charger Circuitry

The simplified built-in charger circuit diagram is as below ;

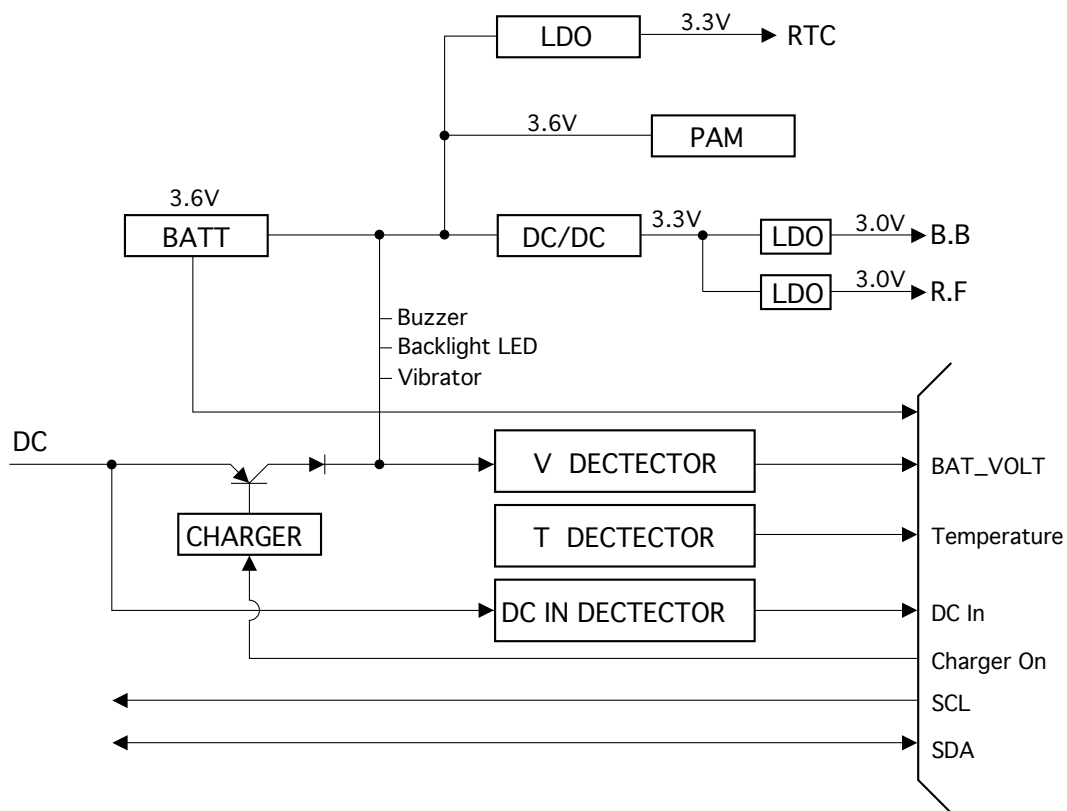

< Fig. 4 Built-in Charger Circuitry >

2-5 RADIO INTERFACE

2-5-1 RF Block Diagram

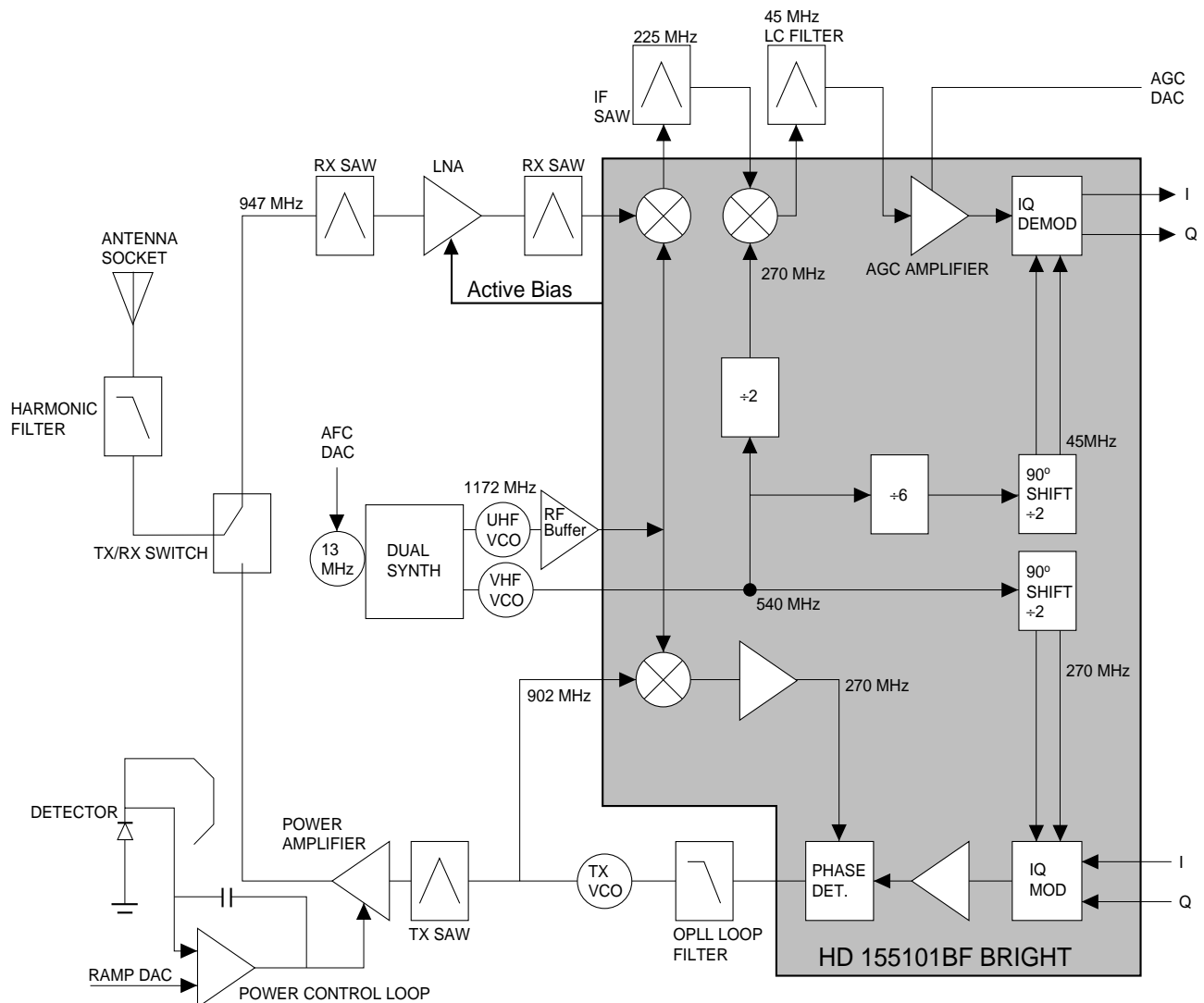

< Fig. 5 RF Block Diagram >

2-5-2 Baseband Filter

To control the spectral splatter and thus the intersymbol interference (ISI), filtering is applied to the baseband pulses. The required filtering is achieved very simply using a small, low cost discrete LC structure, which has the great advantage of not consuming current.

2-6 AUDIO

2-6-1 Audio Inputs

The Handset provides two audio inputs:

- Built in microphone
- Connection for external microphone

A microphone biasing amplifier reduces component count in the overall system design:

- Supply: 2.2 V regulated to $\pm 20\%$
- Different output to eliminate possible coupling noise problems, MICBIASP and MICBIASN
- Maximum current: 500 μ A
- Maximum load: 200 pF

2-7 EXTERNAL INTERFACE

A 18 pin connector is mounted on the bottom corner of the PCB. The antenna external connection is on the right hand side of this connector.

2-8 KERNEL SPECIFICATION

2-8-1 FEATURES

- Complete Layer 1 support
- TDMA burst building (ETSI Rec.5-02)
- Coding and interleaving (Rec. 5-03)
- GMSK with differential coding (Rec. 5-04)
- Programmable power template for Tx burst control
- AGC in Receive mode
- I,Q inputs or single intermediate frequency (IF) input
- Detection of FCCH, SCH, Normal and Dummy Bursts
- Flash ROM programming abilities
- Auxiliary ADC for battery voltage and temperature monitoring

2-8-2 Equalizer

MAJOR FEATURES

- Frequency Correction Burst Correction
- Frequency Correction Burst Frequency Measurement
- Synchronization Burst Long Preamble Correlation
- Normal Burst Short Preamble Correlation
- Channel Impulse Response Generation
- Possible Received Value Generation
- Data Equalization
- Carrier Power Measurement
- Doppler Shift Measurement and Correction
- Scaled 7-Bit Soft Decision
- I and Q component recovered from Received Data

2-9 VOCODER SPECIFICATION

2-9-1 FEATURE

- Complete GSM voice encoding and decoding functions
- DTX function
- Voice Activity Detection (VAD) output
- Fully asynchronous coding and decoding
- A-law PCM conversion
- DTMF generation
- Sidetone level control
- Programmable microphone amplifier with two differential input ports
- Two programmable audio output amplifiers
- 13 MHz master clock

2-10 Desk Top Charger

2-10-1 Charging

The desk-top charger contains switching regulator to charge a lithium battery from an DC/DC adaptor. The battery type is detected at pin 15 (MPU) through U5 (front port) and U26 (rear port). Battery charging current is turned into V_i . V_i is measured at pin 12 (MPU) after R32 and C23 to cancel the noise. When the battery voltage is too low, the charging circuit turns to trickle mode using Q9 and Q11.

2-10-2 Control Part

This circuit contains 4-bit micro controller (U21), including an I/O port, timer, A/D converter to control battery charging. This circuit uses a 4 MHz main clock and +5V power.

BATTERY VOLTAGE DETECTION

Battery voltage from the front port is detected at R20, R18 and measured at pin 13 (MPU).
Battery voltage from the rear port is detected at R14, R13 and measured at pin 14 (MPU).

BATTERY TEMPERATURE DETECTION

The charger always detects the battery temperature via NTC thermistor to prevent battery thermal problems. This circuit is composed of parallel resistors because NTC thermistor has log-scale thermal characteristics. If the battery temperature exceeds 55 degrees C, charging stops.

AUTONOMOUS TIMER

If MPU has stopped charging and the timer goes to the 'on' state by an external shock, overcharging may occur. A timer (U7-4) prevents the battery from being overcharged by any unexpected external influence.

2-11 Cigar Lighter Adaptor (CLA)

2-11-1 General Description

The CLA is a regulated switched-mode power supply designed for use with a portable HHP. The power supply is connected directly to the phone and provides a voltage path for charging a battery installed in the hand-held portable phone.

2-11-2 Circuit Description

The input voltage range of CLA is from 12 Vdc to 30 Vdc, and the nominal voltage is 13.7 Vdc. The output current is 600 mA. The ripple and noise amplitude is less than 50 mV at the input (12 V ~ 30 Vdc). And the limit settings are shown below;

- Current limit : 600 mA \pm 50 mA at nominal input 13.7 V
- Output voltage : 9.0 V (+/- 0.8 V) Vdc at no load.

In addition, the temperature limit is -20 upto +85 °C for storage, and 0 to +40 °C for operating. The CLA size of SGH-600 is 89.3 x 43 x 27 mm, and the weight is 110 g.

2-12 Travel Adaptor (TA)

2-12-1 General Description

This adaptor is designed for use with a portable hand held phone (HHP). It is a switching-mode power supply connected directly to the phone with a cable, and it provides a voltage for charging a battery installed in the hand held portable phone.

2-12-2 Circuit Description

The input voltage range is 85 ~ 264 Vac, and input frequency is 47 ~ 63 Hz. At an input voltage of 230 Vac (standard input voltage), AC input current is 0.1 A(rms). The output voltage range is 9.0 V \pm 10% and the unit maintains current 600 mA \pm 30 mA. The operating temperature is 0 ~ 55 °C, and for storage -20 ~ 85°C. Power ON/OFF cycle is 1.0sec min. The overall size is 74.1 x 28.4 x 79.8 mm and the weight is 65 g without the output DC cable. The charger is an AC/DC switch mode flyback converter featuring constant current and voltage limit. Output cable is two-way DC cable. Maximum output power is 6.4 W.

2-13 Hands Free Car kit

2-13-1 General Description

Many states and countries are considering legislation requiring mobile phone users to operate in Hands-Free mode while driving.

Feature of the hands free kit are:

- Power adaptor (600 mA) from vehicle battery to GSM battery pack.
- Ignition sensor for automatic power ON/OFF.
- Car stereo mute function in Hands-Free mode, with programmable output level.
- External microphone input.
- Loudspeaker output.
- Hands-Free operation.

2-13-2 Circuit Description

The input voltage range is from 12V dc to 28V dc, (battery) and input current is 10mA(stanby). The operating temperature is -10 ~ 60 °C, and for storage temperature is - 30 ~ 85 °C(± 5 °C). The charging voltage is DC9V and charging current is MAX 600mA.

2-13-3 Audio Features

- Microphone Sensitivity: -60 dB ± 3 dB
- Speaker S/N: -45 dB ± 3 dB (1W Output)
- Speaker Distortion: 20% below (3W Output)
- Speaker Feature: Impedance 4Ω, Max 5W Output
- Echo Cancellation: 50 dB (Min)
- Noise Suppression: 15 dB (Min)

5. Troubleshooting

5-1 Main Set

5-1-1 RX Sensitivity Problem

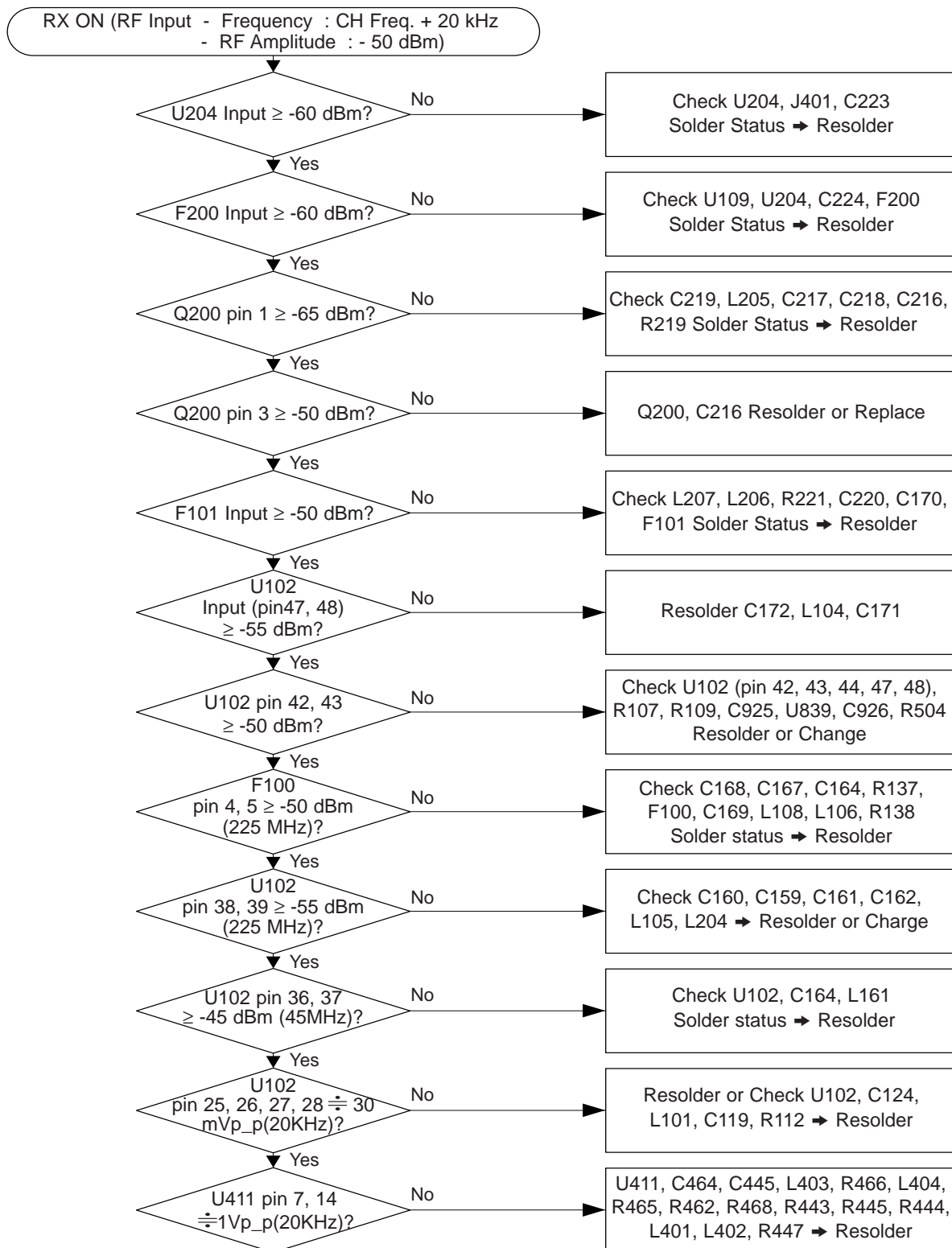

5-1-2 TX Power Problem

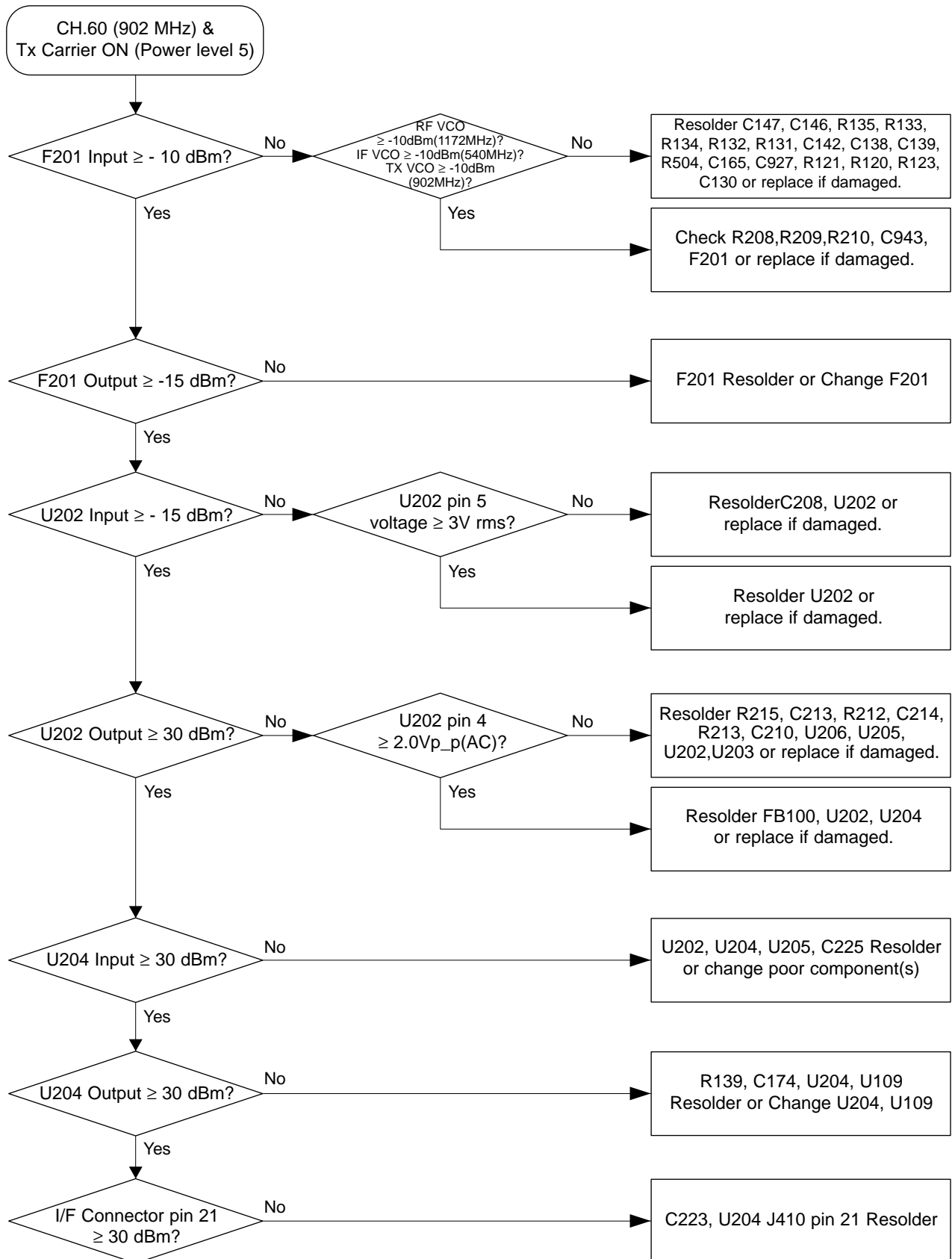

5-1-3 Base Band

POWER ON

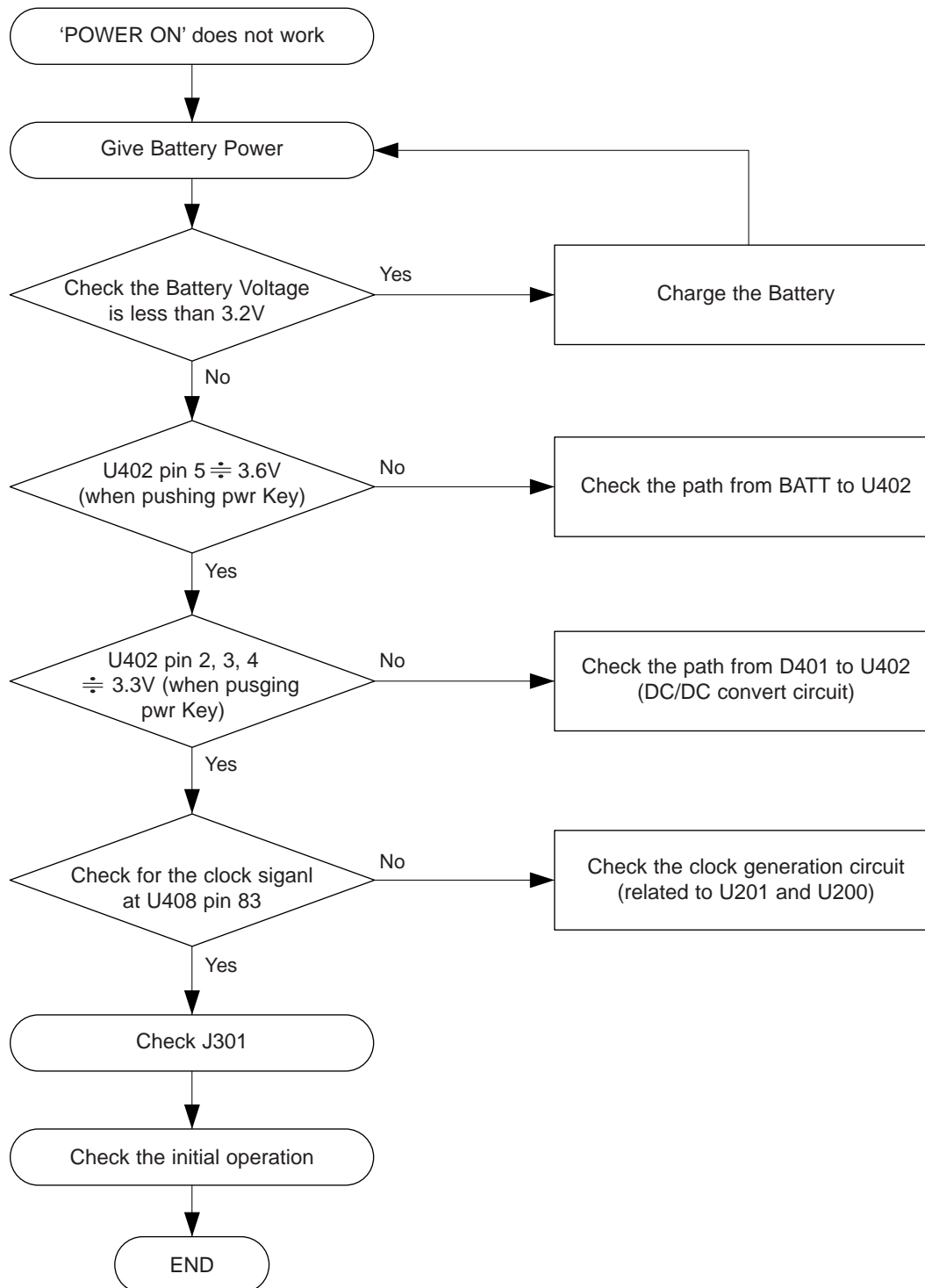

INITIAL OPERATION



BACKLIGHT

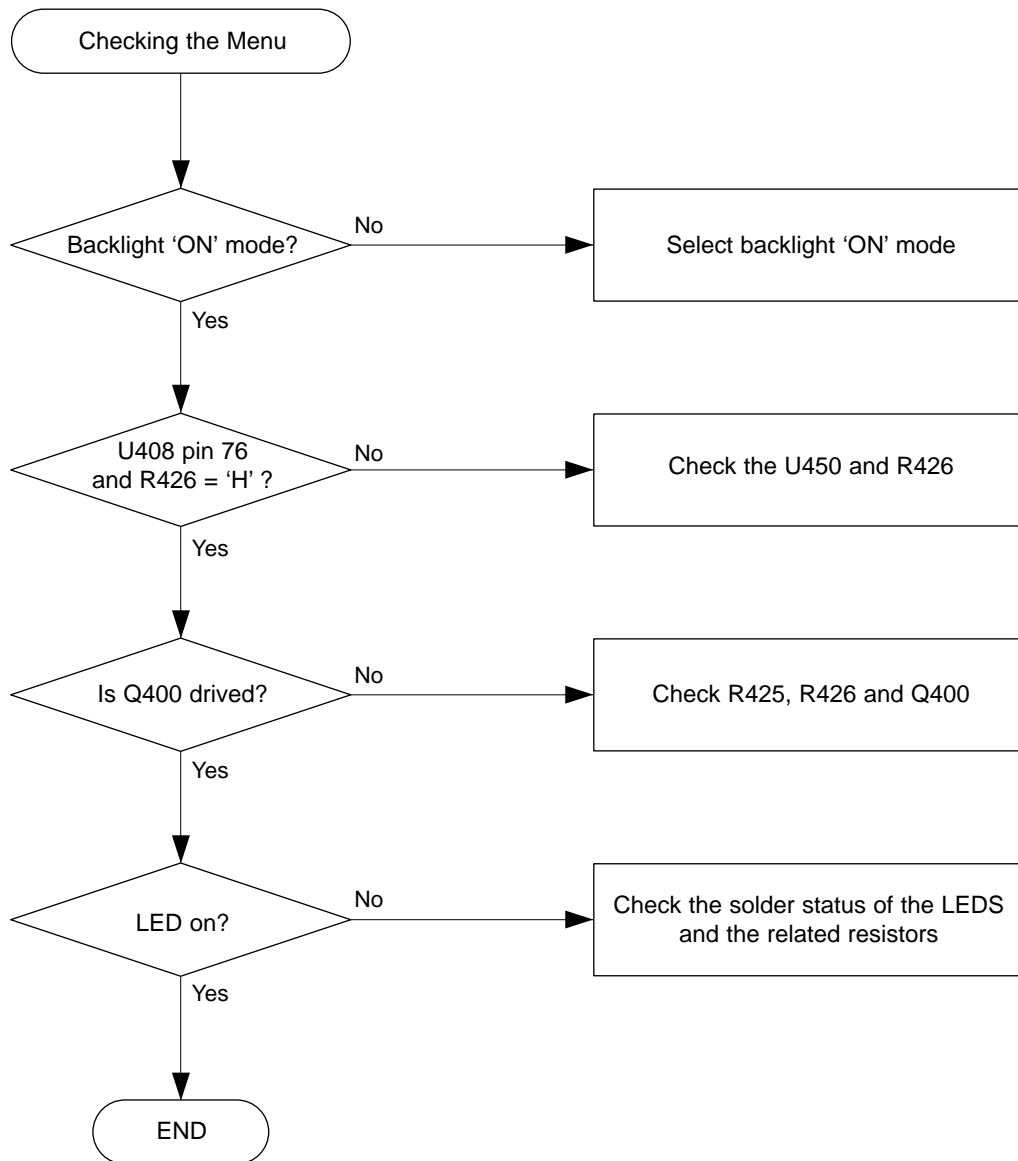

RING INDICATOR LED

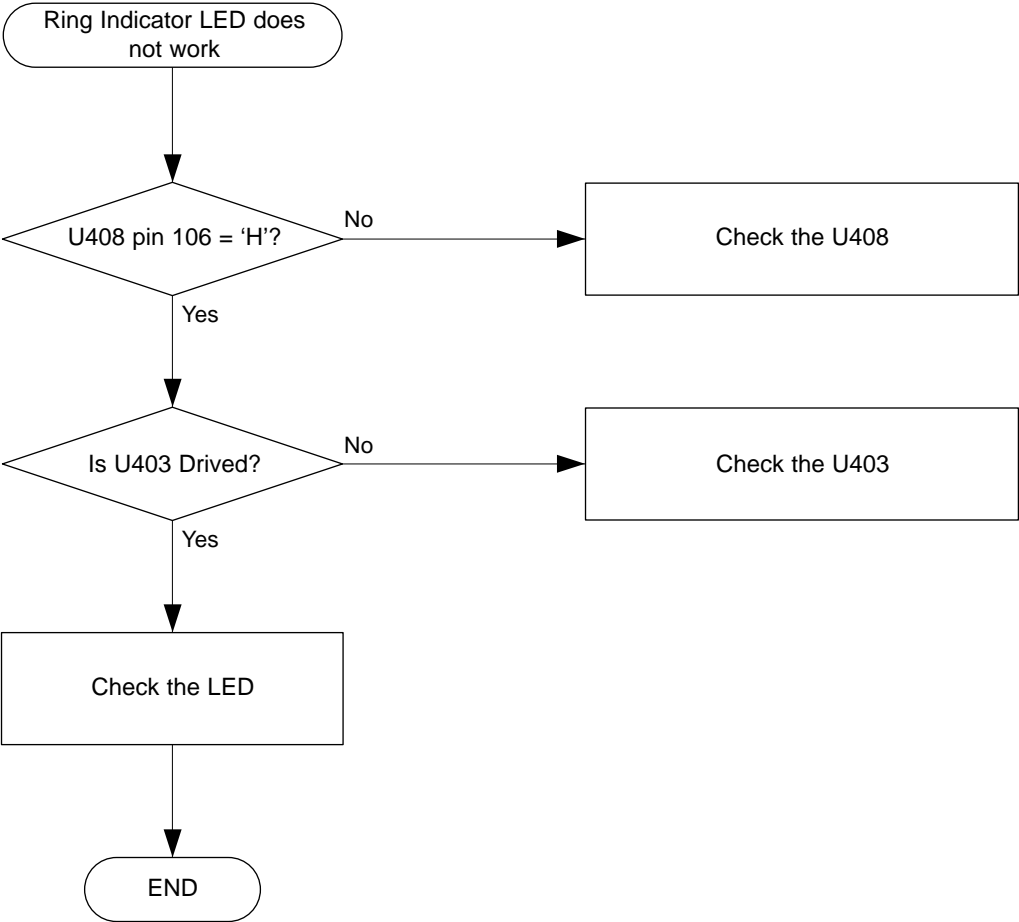

SIM CARD PART

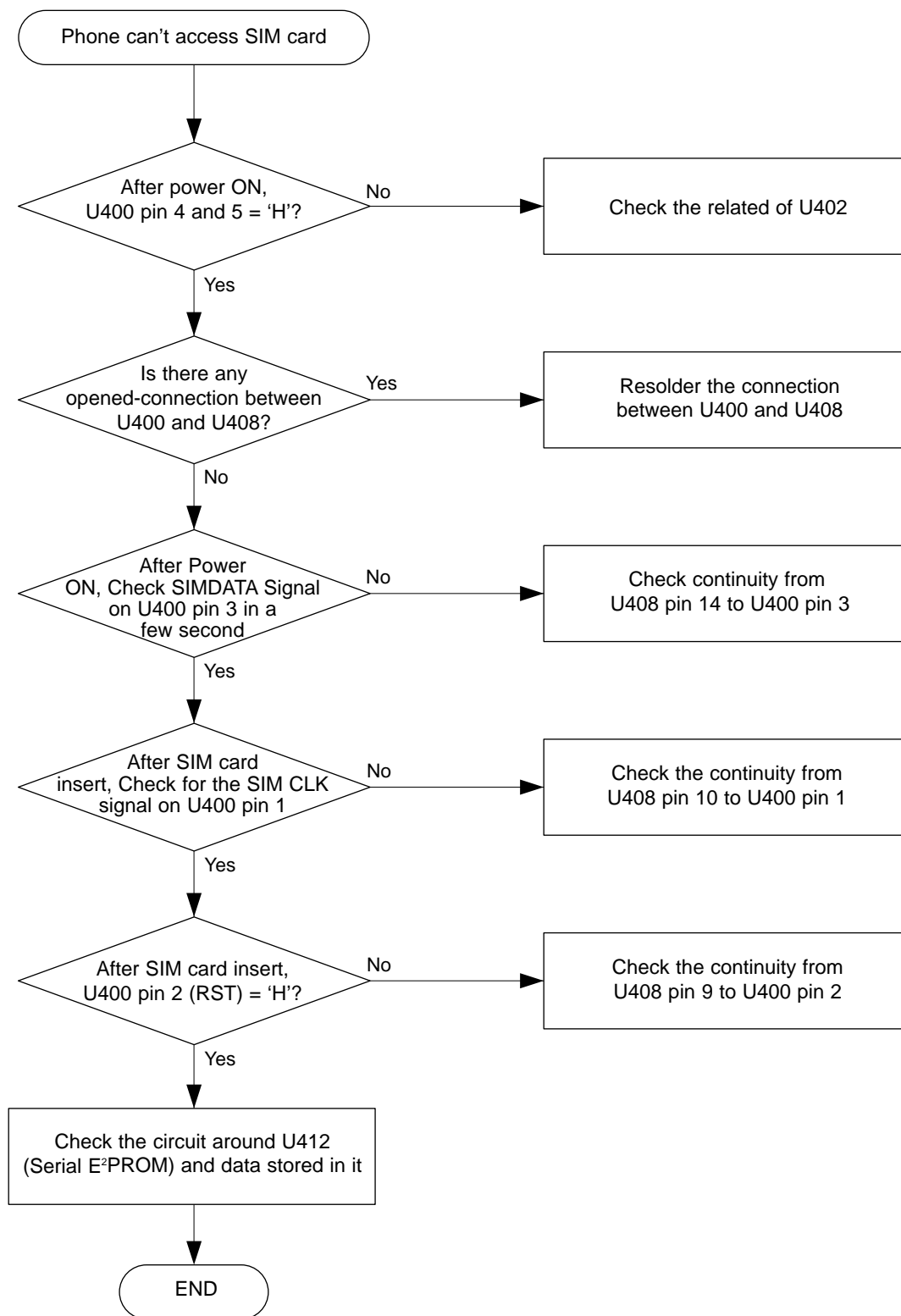

KEY DATA INPUT

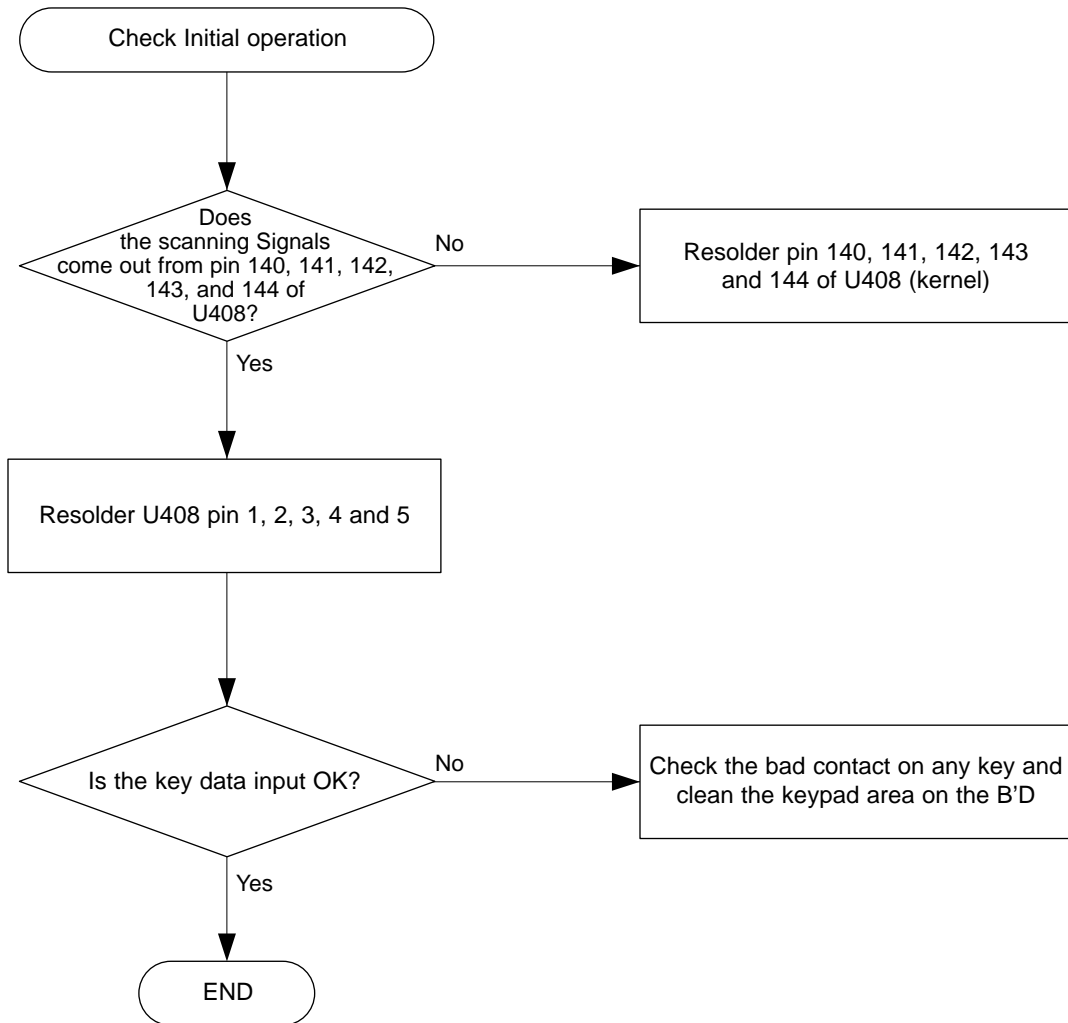

ALERT TONE

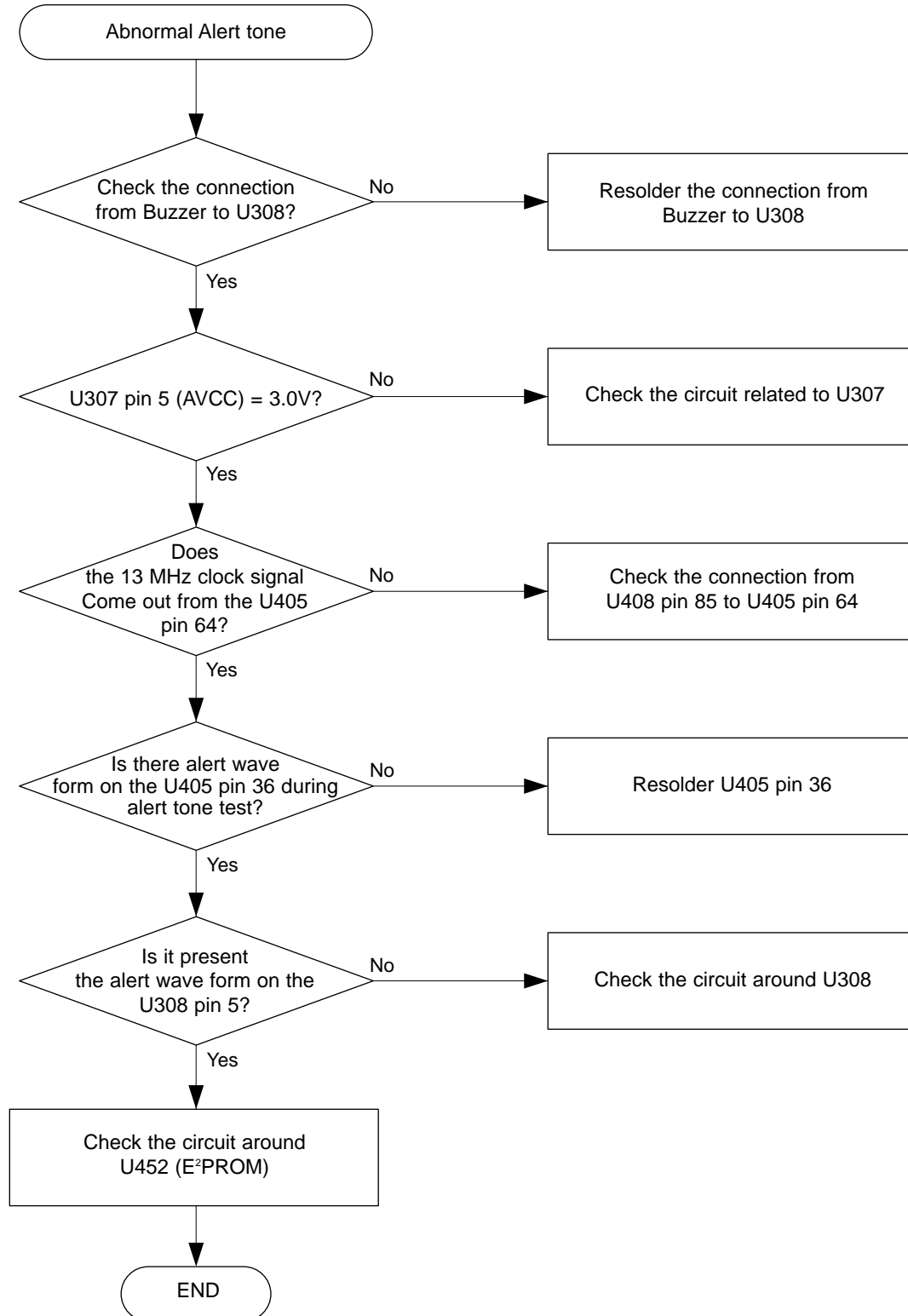

MICROPHONE PART

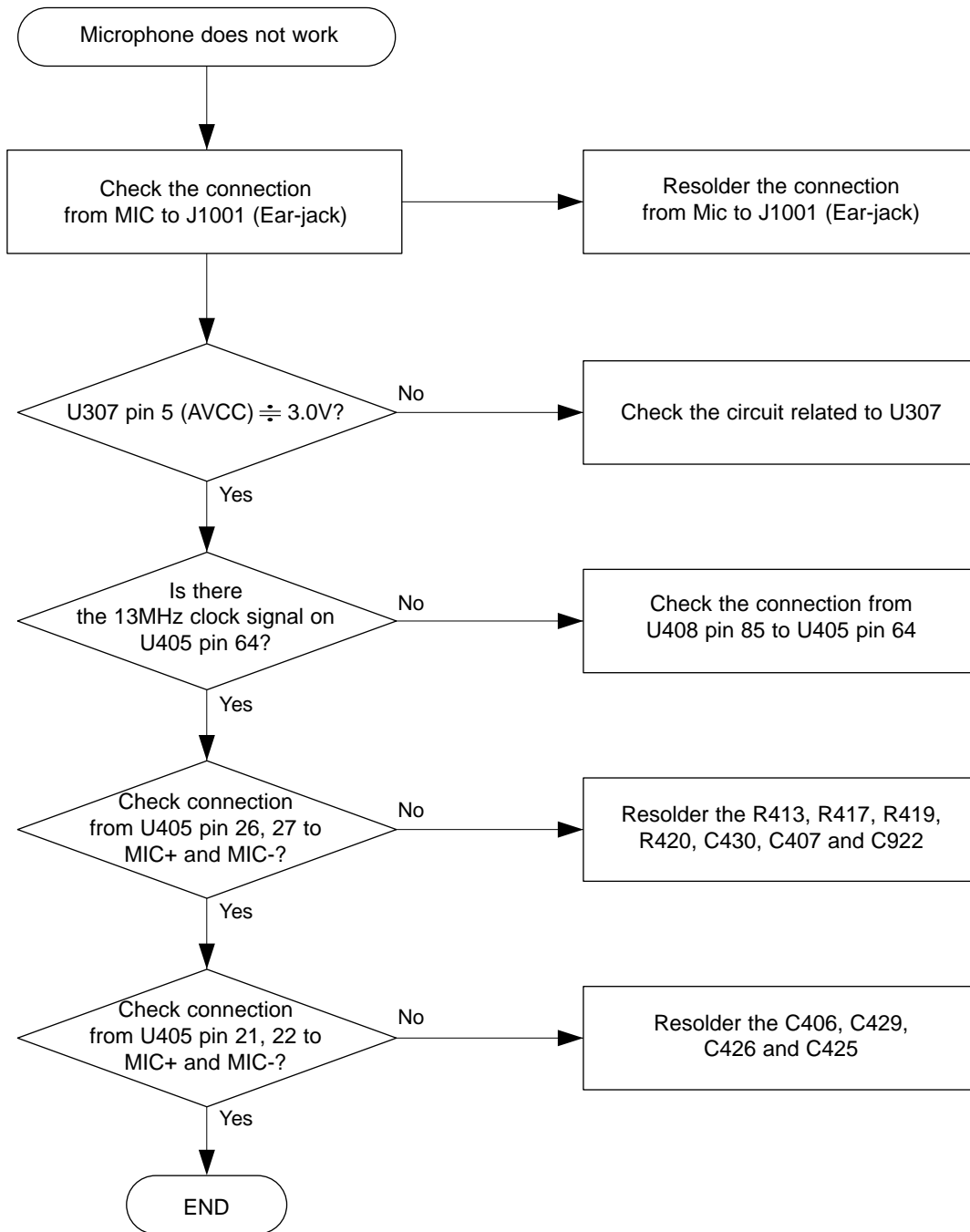

SPEAKER PART

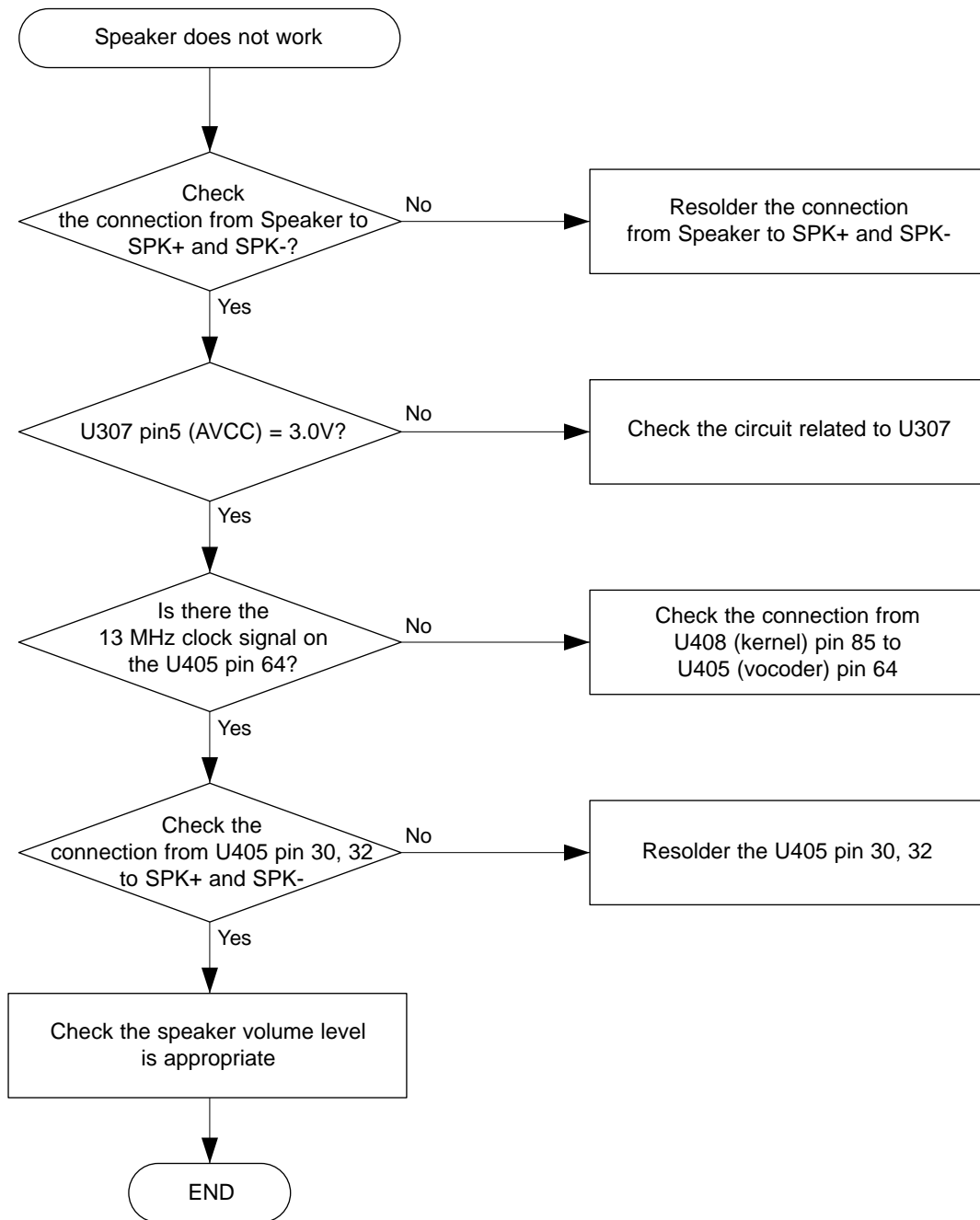

CHARGING PART

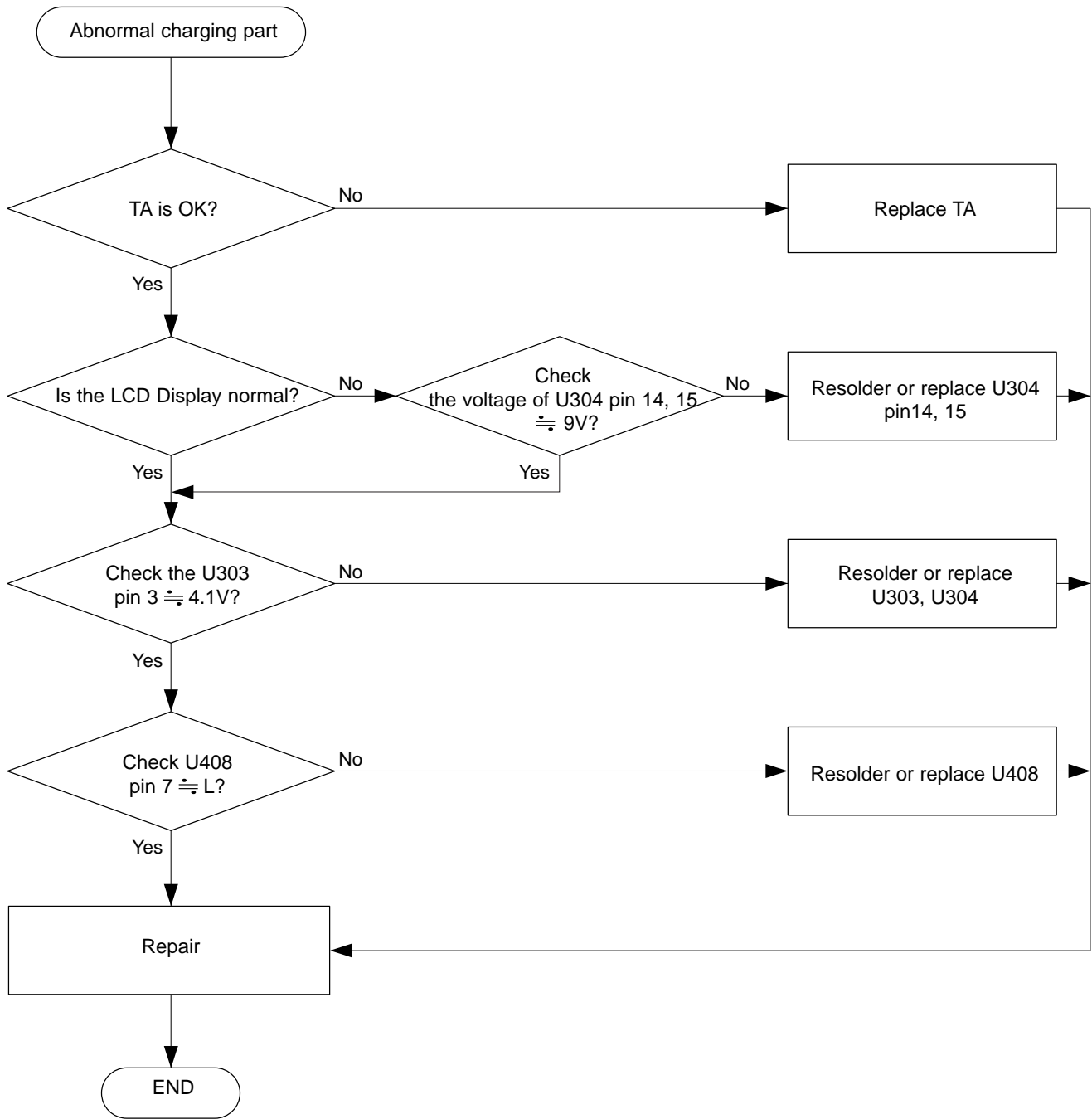

1. Exploded Views and Parts List

1-1 Main

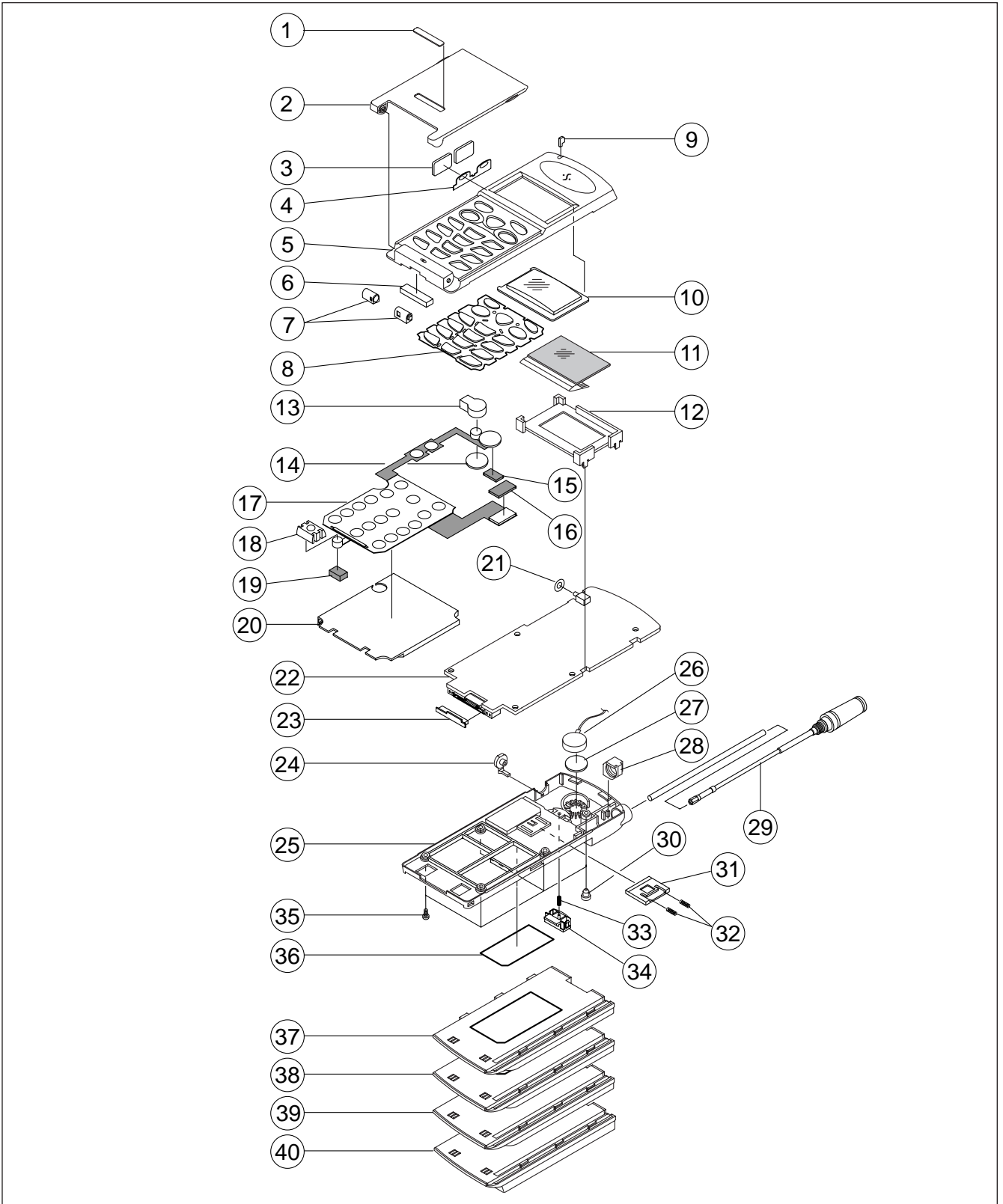

1-2 Main Parts List

NO	DESCRIPTION	SEC.CODE	Q'TY	REMARK
1	BADGE		1	
2	FLIP COVER		1	
3	KEY VOLUMN		1	
4	PUBBER-KEY		1	
5	FRONT COVER		1	
6	SPONGE S/W		1	
7	HINGE ASS'Y		2	
8	KEY-MAIN		1	
9	LED LENS		1	
10	SUA. WINDOW		1	
11	LCD		1	
12	LCD FRAME		1	
13	RUBBER-BUZZER		1	
14	SUPPORT BUZZER		1	
15	SUPPORT-SPK		1	
16	SUPPORT-CON.		1	
17	KEY-PCB		1	
18	HOLDER-MIC		1	
19	SPONGE-MIC		1	
20	SHIELD-FRAME		1	
21	JACK-COVER		1	
22	PCB		1	
23	COVER-CONNECTOR			
24	EAR-COVER			
25	REAR COVER		1	
26	MOTOR		1	
27	TAPE-MOTOR		1	
28	ANT.BRAKET		1	
29	ANTENNA		1	
30	RUBBER CAP		1	
31	SIM COVER		1	
32	SPRING-SIM		1	
33	SPRING-LOCKER		1	
34	LOCKER-MAIN		1	
35	SCREW MACHINE		1	
36	MAIN LABEL		1	
37	SLIM BATT.		1	
38	STD BATT.			

NO	DESCRIPTION	SEC.CODE	Q'TY	REMARK
39	EXT.BATT			
40	ULTRA EXT. BATT			

1-3 Travel Adapter

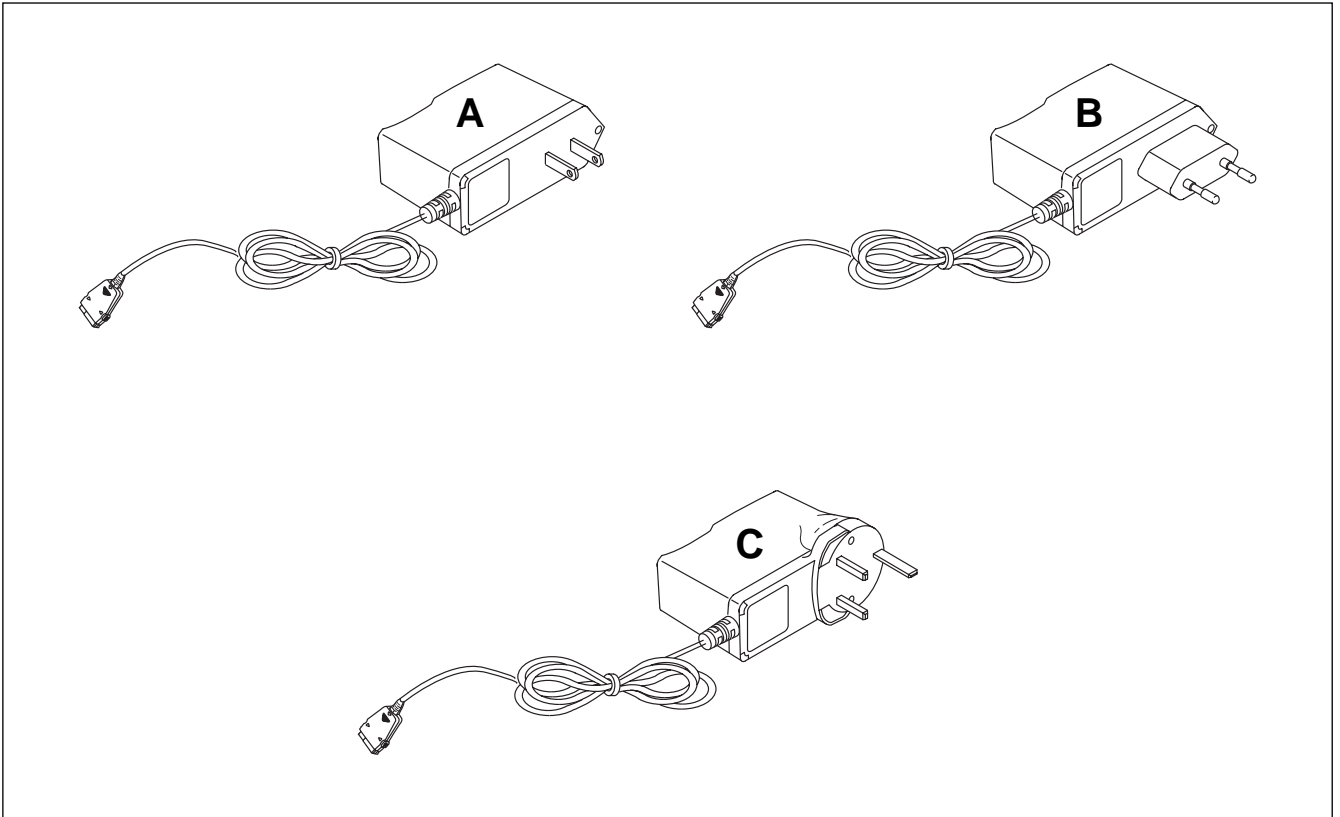

1-4 Travel Adapter Parts List

TYPE	SEC CODE	REMARK
A	GH96-01143A	CHINA
B	GH96-01146A	EUROPE
C	GH96-01095A	UNITED KINGDOM

1-5 Desk Top Charger

SEC CODE : GH44-00090A

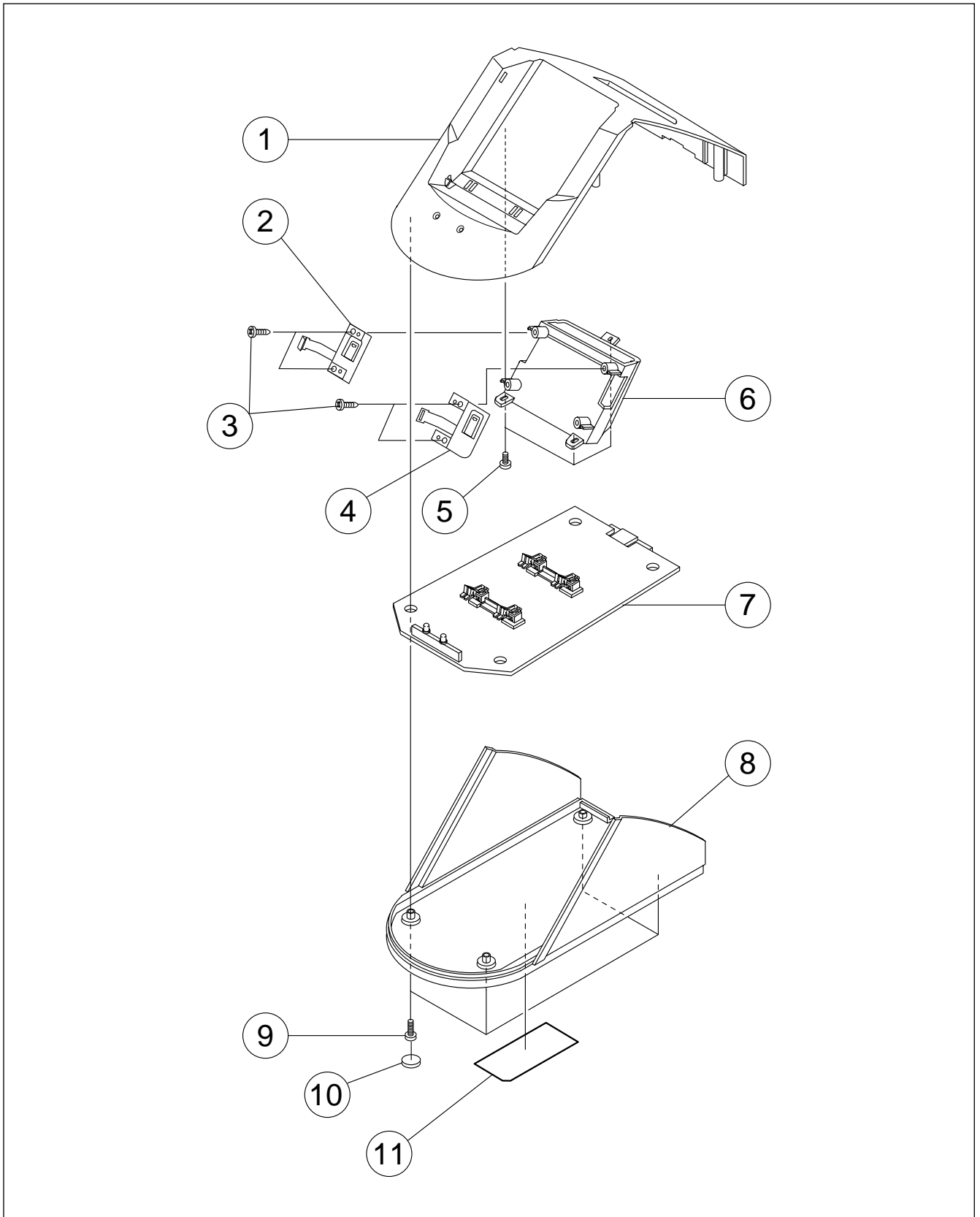

1-6 Desk Top Charger Parts List

NO	DESCRIPTION	SEC.CODE	Q'TY	REMARK
1	UPPER CASE		1	
2	HANGER SPRING (L)		1	
3	SCREW TAPPING		4	
4	HANGER SPRING (R)		1	
5	SCREW TAPPING		3	
6	BATT. HOUSING		1	
7	PCB		1	
8	LOWER BASE		1	
9	SCREW TAPPING		4	
10	BUMPON		4	
11	LABEL		1	

1-7 Ciger Light Adapter

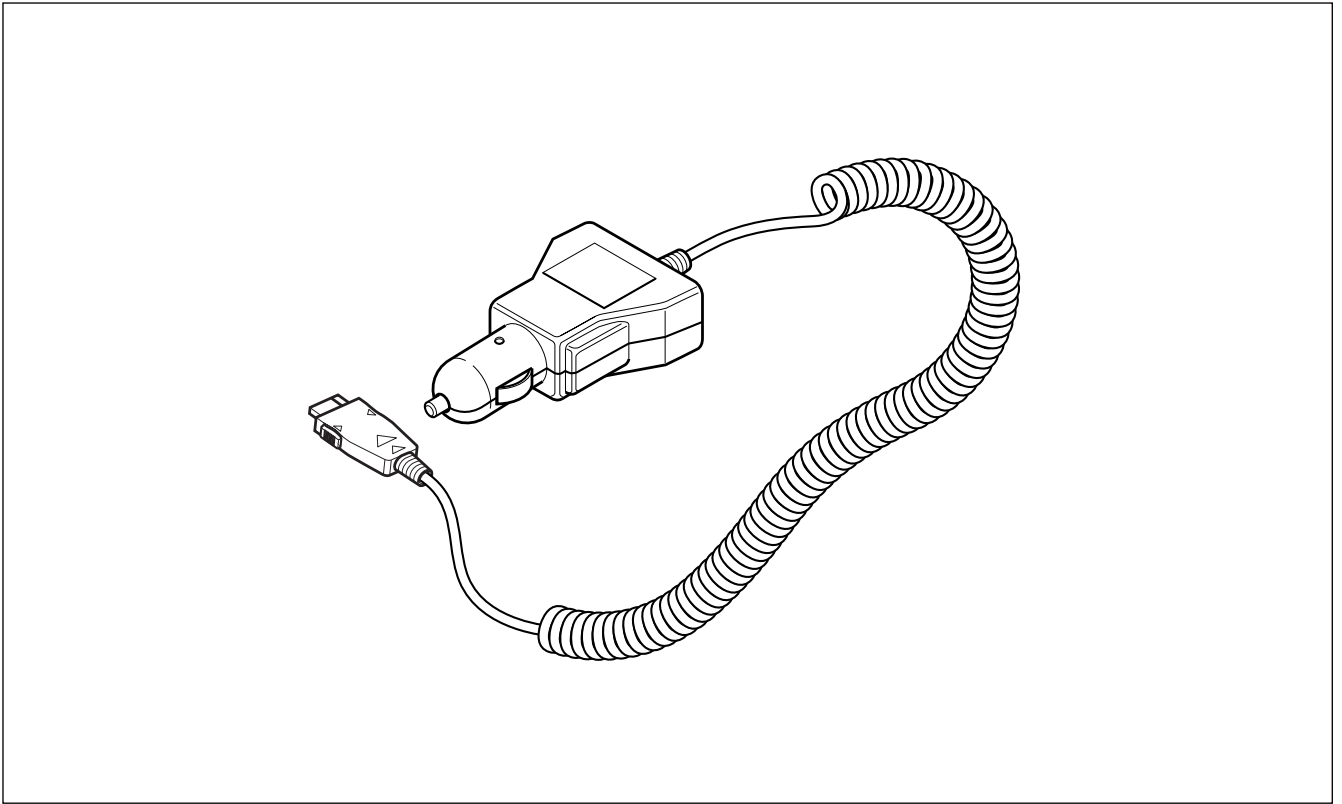

1-8 Ciger Light Adapter Parts List

DESCRIPTION	SEC CODE	REMARK
Ciger Light Adapter Code	GH44-00040A	BLACK

1-9 Hands Free Kit

SEC CODE : GH96-00800A

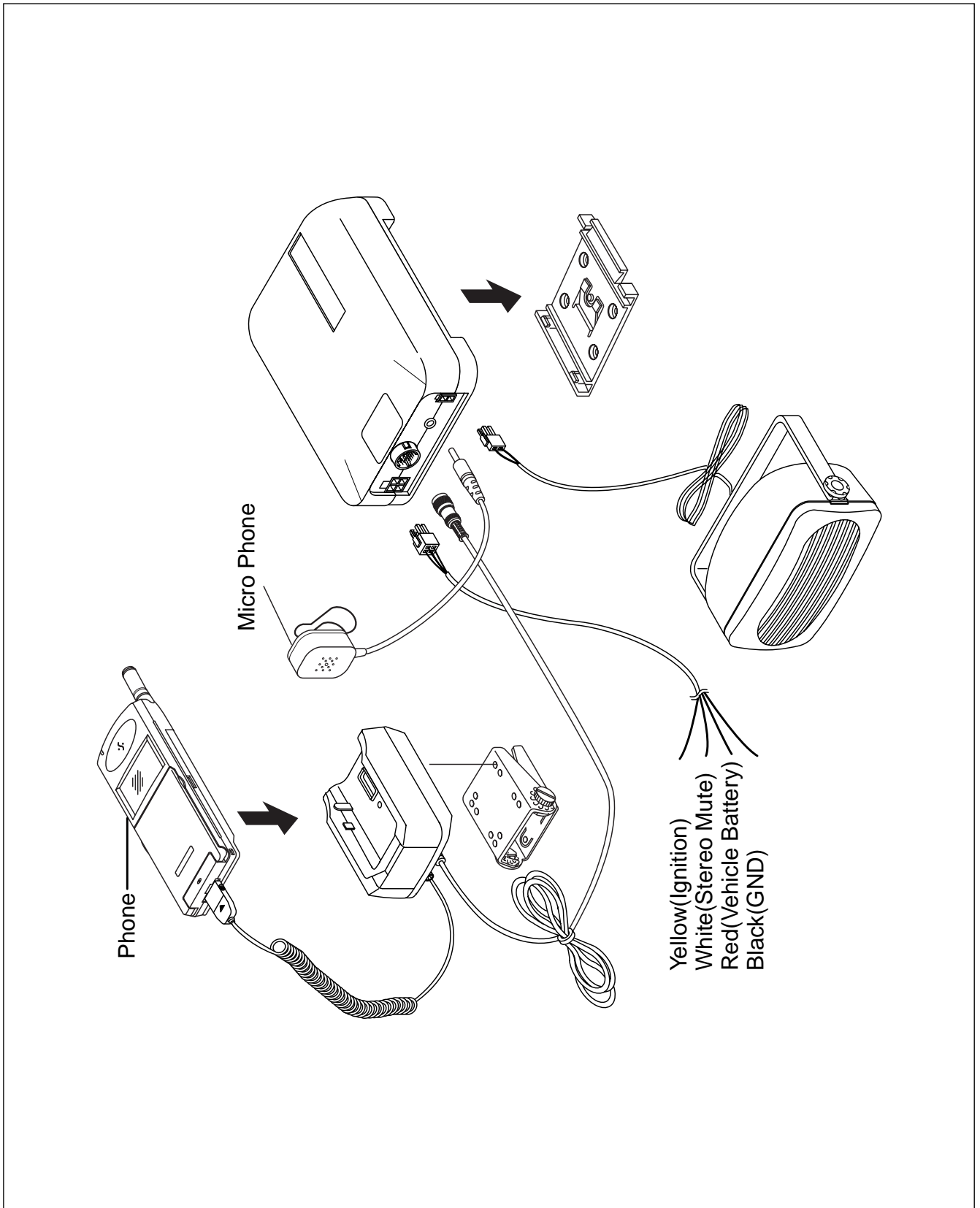

1-10 Test Jig

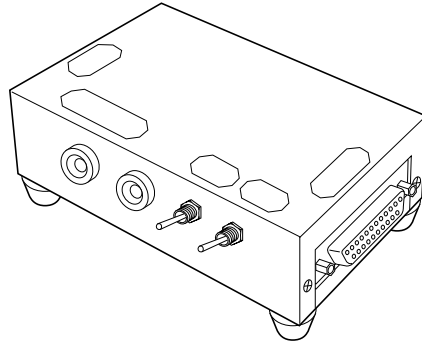

TEST JIG

GH80-10508A

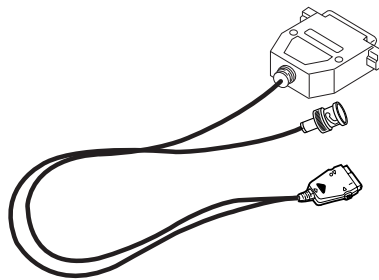

DATA CABLE

GH39-30532A

1-11 Earphone

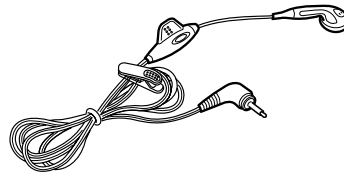

EARPHONE

GH96-00830A

2 Electrical Parts List

2-1 Main Parts List

REFERENCE	SEC.CODE	DESCRIPTIONS
D401,D801	0401-001033	Diode-Switching,25V,200mA
D253,D255,D808	0404-001044	Diode-Schottky,20V,1A,SMD
D400	0404-001054	Diode-Schottky,70V,15mA,SOT-143
D600	0405-001051	Diode-Varactor,4.7V,50nA,SOT-23
D101,D102,D176,D820,D903	0406-001084	ESD Diode
D252	0407-001002	Diode-Array,80V,300mA,CA2-3
D901,D902	0407-001006	Diode-Array,20V,100mA,C2-3
D251	0407-001007	Diode-Array,80V,25mA,CA4-2
Q958	0501-000162	TR-SMALL SIGNAL,PNP,200mW,SOT-323
Q951	0501-002011	TR-SMALL SIGNAL,NPN,200mW,SOT-23
Q300	0501-002037	TR-SMALL SIGNAL,MPN,55mW,SOT-434
Q601,Q604	0501-002196	TR-SMALL SIGNAL,NPN,280mW,SOT-323
U307	0501-002205	TR-SMALL SIGNAL,NPN,SOT-343
Q151,Q153,Q255	0504-000167	TR-Digital,NPN,100mW,10K10Kohm
Q256,Q257	0504-000168	TR-Digital,NPN,100mW,47K47Kohm
Q500	0505-000110	FET-SILICON,60V,115mA,200mW
U501,U502	0505-001131	FET-SILICON,-12V,-500mA,690mohm
Q950,Q957	0505-001332	FET-SILICON
Q600	0506-000173	TR-ARRAY,NPN,80mW,SOT-363
U128,U252,U302,U303,U400,U403,U412,U813	0506-001004	TR-ARRAY,NPN/PNP,50V,-100mA
LED100	0601-000276	LED/CHIP
U902,U903	0801-000022	IC-CMOS LOGIC,NANDGATE,SOP,5P
U900,U901,U904,U906	0801-000794	IC-CMOS LOGIC,ANDGATE,SOT-25,5P
U905	0801-002345	IC-CMOS LOGIC,INVERTER,SOP,5P
U413,U414	0801-002349	IC-CMOS LOGIC
U962,U963	1001-001088	ANALOG SWITCH
U969	1003-001226	IC-POWER DRIVER,SOP,8P,120MIL
U203	1103-001090	IC-EEPROM,16Kx8Bit,SOP,8P,150MIL
U105	1106-001287	IC-SRAM
U103	1107-001111	IC-Flash memory
U104	1107-001164	IC-Flash memory
U406	1201-001018	IC-OP AMP,SOT-23,5P,Single,70dB
U127	1201-001212	IC-OP AMP,SOP,14P,15V/Mv
U604	1201-001248	IC-CASCADE AMP,SOT-143,4P,2.7V
U402	1201-001299	IC-POWER Amp,RF-K,8P,SINGLE,8V
U408	1201-001411	IC-POWER Amp
U960	1202-001022	IC-VOLTAGE COMP,SSOP,8P,110MIL,7V
U801,U803,U805,U806,U810,U811	1203-001285	IC-SWITCH VOL REG,SOT-23,5P,150MIL

REFERENCE	SEC.CODE	DESCRIPTIONS
U809	1203-001511	IC-Reset,SOT-23,3P
U253	1203-001515	IC-BATTERY,SSOP,16P,150MIL
U804	1203-001592	IC-VOLTAGE REGULATOR,SOT-23,5P
U812	1203-001702	IC-DC/DC CONVERTER,SOP,10P,112MIL
U102	1203-001740	IC-DC/DC CONVERTER,SOP,16P,150MIL
U301	1204-001006	IC-IP SYSTEM,SOP,20P,205MIL
U300,U305	1205-001307	IC-MIXER,SOP,16P,197MIL
U200	1205-001643	IC-KERNEL
U950	1205-001697	IC-VOCODER,QFP,80P,3V
U202	1206-001009	IC-TIMER,SOP,8P,173MIL
U603	1209-001220	IC-PLL SYSTEM,SOP,20P,173MIL
U500	1209-001233	IC-PLL SYSTEM,SSOP,28P
TH1	1404-001005	THERMISTOR,47Kohm,5%,4054K,20mW
D179	1405-001018	Varistors
D103,D104,D819	1405-001019	Varistors
R184	2007-000070	R-CHIP,0ohm,5%,1/16W,DA,TP,1608
R105,R129,R135,R163,R177,R178,R179,R180,R181 R182,R183,R185,R186,R187,R188,R621,R653	2007-000138	R-CHIP,100ohm,5%,1/16W,DA,TP,1005
R644,R978	2007-000139	R-CHIP,220ohm,5%,1/16W,DA,TP,1005
R220,R221,R264,R529,R611,R646,R811,R951,R954	2007-000140	R-CHIP,1Kohm,5%,1/16W,DA,TP,1005
R640	2007-000141	R-CHIP,2.2Kohm,5%,1/16W,DA,TP,1005
R309,R609	2007-000142	R-CHIP,2.7Kohm,5%,1/16W,DA,TP,1005
R351	2007-000143	R-CHIP,4.7Kohm,5%,1/16W,DA,TP,1005
R606,R628	2007-000145	R-CHIP,6.2Kohm,5%,1/16W,DA,TP,1005
R603	2007-000146	R-CHIP,6.8Kohm,5%,1/16W,DA,TP,1005
R104,R152,R205,R210,R232,R235,R238,R253,R256,R363 R418,R419,R605,R630,R637,R906,R907,R952,R962,R963 R984,R985,R996,R255	2007-000148	R-CHIP,10Kohm,5%,1/16W,DA,TP,1005
R300	2007-000152	R-CHIP,20Kohm,5%,1/16W,DA,TP,1005
R622	2007-000153	R-CHIP,22Kohm,5%,1/16W,DA,TP,1005
R126,R208,R218,R219,R352,R353	2007-000157	R-CHIP,47Kohm,5%,1/16W,DA,TP,1005
R257	2007-000159	R-CHIP,56Kohm,5%,1/16W,DA,TP,1005
R100,R101,R102,R151,R153,R162,R209,R212,R213,R214 R222,R231,R251,R252,R254,R263,R528,R812,R972,R980	2007-000162	R-CHIP,100Kohm,5%,1/16W,DA,TP,1005
R610,R639	2007-000164	R-CHIP,150Kohm,5%,1/16W,DA,TP,1005
R215,R312,R326,R361,R505,R531,R631,R647,R968,R986	2007-000171	R-CHIP,0ohm,5%,1/16W,DA,TP,1005
R308,R500,R501,R502,R503,R504,R517,R524,R527,R601 R602,R607,R633,R638,R650	2007-000172	R-CHIP,10ohm,5%,1/16W,DA,TP,1005
R651,R654	2007-000173	R-CHIP,22ohm,5%,1/16W,DA,TP,1005
R515,R516,R518	2007-000932	R-CHIP,470ohm,5%,1/16W,DA,TP,1005
R130,R136,R417	2007-001119	R-CHIP,680ohm,5%,1/16W,DA,TP,1005
R428	2007-001217	R-CHIP,82ohm,5%,1/16W,DA,TP,1005

REFERENCE	SEC.CODE	DESCRIPTIONS
R304,R623,R625,R627	2007-001288	R-CHIP,18ohm,5%,1/16W,DA,TP,1005
R431	2007-001295	R-CHIP,39ohm,5%,1/16W,DA,TP,1005
R305,R364,R410,R420,R511,R519,R520,R648,R649	2007-001298	R-CHIP,51ohm,5%,1/16W,DA,TP,1005
R445	2007-001301	R-CHIP,68ohm,5%,1/16W,DA,TP,1005
R404,R406,R617	2007-001305	R-CHIP,120ohm,5%,1/16W,DA,TP,1005
R430,R432	2007-001306	R-CHIP,150ohm,5%,1/16W,DA,TP,1005
R306,R311,R316,R317	2007-001307	R-CHIP,180ohm,5%,1/16W,DA,TP,1005
R613,R805	2007-001308	R-CHIP,200ohm,5%,1/16W,DA,TP,1005
R128,R134	2007-001311	R-CHIP,270ohm,5%,1/16W,DA,TP,1005
R356,R357,R365,R525,R526,R950,R953	2007-001313	R-CHIP,330ohm,5%,1/16W,DA,TP,1005
R612	2007-001316	R-CHIP,820ohm,5%,1/16W,DA,TP,1005
R507,R512	2007-001317	R-CHIP,910ohm,5%,1/16W,DA,TP,1005
R629	2007-001323	R-CHIP,3Kohm,5%,1/16W,DA,TP,1005
R354,R608	2007-001325	R-CHIP,3.3Kohm,5%,1/16W,DA,TP,1005
R618,R643	2007-001339	R-CHIP,180Kohm,5%,1/16W,DA,TP,1005
R413	2007-002797	R-CHIP,560ohm,5%,1/16W,DA,TP,1005
R301	2007-003020	R-CHIP,4.3Kohm,5%,1/16W,DA,TP,1005
R427,R429	2007-003030	R-CHIP,91ohm,5%,1/16W,DA,TP,1005
R407	2007-007001	R-CHIP,3.9Kohm,5%,1/16W,DA,TP,1005
R521	2007-007090	R-CHIP,11Kohm,5%,1/16W,DA,TP,1005
R510	2007-007095	R-CHIP,390ohm,5%,1/16W,DA,TP,1005
R362	2007-007096	R-CHIP,160ohm,5%,1/16W,DA,TP,1005
R132,R137,R259	2007-007107	R-CHIP,100Kohm,1%,1/16W,DA,TP,1005
R265	2007-007133	R-CHIP,300ohm,1%,1/16W,DA,TP,1005
R261	2007-007135	R-CHIP,18K,1%,1/16W,DA,TP,1005
R434,R619,R900,R903,R905	2007-007137	R-CHIP,1.2Kohm,1%,1/16W,DA,TP,1005
R522	2007-007141	R-CHIP,240ohm,5%,1/16W,DA,TP,1005
R904,R987	2007-007142	R-CHIP,10Kohm,1%,1/16W,DA,TP,1005
R514,R523,R626,R645,R652	2007-007195	R-CHIP,3.9ohm,5%,1/16W,DA,TP,1005
R262,R416	2007-007309	R-CHIP,12Kohm,1%,1/16W,DA,TP,1005
R266,R414	2007-007310	R-CHIP,8.2Kohm,1%,1/16W,DA,TP,1005
R412	2007-007311	R-CHIP,22Kohm,1%,1/16W,DA,TP,1005
R409	2007-007316	R-CHIP,3.3Kohm,1%,1/16W,DA,TP,1005
R200,R201,R202,R203	2007-007317	R-CHIP,2.2Kohm,1%,1/16W,DA,TP,1005
R121,R127,R133,R303,R313,R415,R994,R995	2007-007318	R-CHIP,1Kohm,1%,1/16W,DA,TP,1005
R435,R655	2007-007588	R-CHIP,1.8Kohm,1%,1/16W,DA,TP,1005
R258	2007-007590	R-CHIP,82Kohm,1%,1/16W,DA,TP,1005
R260	2007-007592	R-CHIP,270K,1%,1/16W,DA,TP,1005
R979,R981	2007-007627	R-CHIP,16Kohm,1%,1/16W,DA,TP,1005
R983	2007-007630	R-CHIP,14Kohm,1%,1/16W,DA,TP,1005
R355,R902	2007-007788	R-CHIP,332ohm,1%,1/16W,DA,TP,1005
C524	2203-000151	C-CHIP,1.5nF,5%,50V,TP,2012

REFERENCE	SEC.CODE	DESCRIPTIONS
C215,C216,C217,C218,C303,C318,C337,C362,C368,C411,C416 C501,C502,C503,C508,C509,C516,C521,C623,C628,C635,C642	2203-000233	C-CHIP,100pF,5%,50V,TP,1005
C348,C512	2203-000278	C-CHIP,10pF,5%,50V,TP,1005
C445	2203-000311	C-CHIP,120pF,5%,50V,TP,1005
C310,C539,C604	2203-000330	C-CHIP,12pF,5%,50V,TP,1005
C625	2203-000359	C-CHIP,150pF,5%,50V,TP,1005
C316,C431,C514,C951,C958,C959,C968,C969,C970,C991,C993	2203-000386	C-CHIP,15pF,5%,50V,TP,1005
C127,C135,C207,C311,C351,C352,C354,C356,C361,C371,C373 C375,C379,C504,C522,C621,C627,C637,C641,C966,C967	2203-000438	C-CHIP,1nF,10%,50V,TP,1005
C624	2203-000455	C-CHIP,1nF,5%,50V,TP,2012
C409	2203-000585	C-CHIP,220pF,10%,50V,TP,1005
C950,C956	2203-000604	C-CHIP,22nF,10%,25V,TP,1608
C305,C330,C374,C376,C378,C415,C505,C506,C515,C611,C617	2203-000628	C-CHIP,22pF,5%,50V,TP,1005
C405,C418,C423,C428,C454,C457,C458,C459,C460,C510,C511 C517,C520,C529,C530,C632,C633,C639	2203-000679	C-CHIP,27pF,5%,50V,TP,1005
C346	2203-000696	C-CHIP,2pF,5%,50V,TP,1005
C128,C136,C609	2203-000725	C-CHIP,3.9nF,10%,50V,TP,1005
C614	2203-000800	C-CHIP,33nF,10%,25V,TP,1608
C302,C306,C319	2203-000812	C-CHIP,33pF,5%,50V,TP,1005
C610	2203-000836	C-CHIP,390pF,10%,50V,TP,1005
C325	2203-000854	C-CHIP,39pF,5%,50V,TP,1005
C304,C357,C810,C819,C862,C867	2203-000940	C-CHIP,470pF,10%,50V,TP,1005
C321,C350,C353,C377,C647	2203-001017	C-CHIP,4pF,5%,50V,TP,1005
C1004	2203-001033	C-CHIP,5.6nF,10%,25V,TP,1005
C518,C519	2203-001072	C-CHIP,56pF,5%,50V,TP,1005
C165,C166,C167,C168	2203-001101	C-CHIP,6.8nF,10%,25V,1005
C507,C513	2203-001153	C-CHIP,68pF,5%,50V,TP,1005
C300,C307,C315,C540,C606	2203-001178	C-CHIP,6pF,5%,50V,TP,1005
C314,C339	2203-001201	C-CHIP,7pF,5%,50V,TP,1005
C410,C430	2203-001221	C-CHIP,820pF,10%,50V,TP,1005
C613	2203-001259	C-CHIP,8pF,5%,50V,TP,1005
C169	2203-001402	C-CHIP,220nF,+80-20%,16V,TP,1608
C523	2203-001408	C-CHIP,270pF,5%,50V,TP,1608
C429	2203-002525	C-CHIP,560pF,10%,50V,TP,1005
C313	2203-002668	C-CHIP,0.5pF,0.1pF,50V,TP,1005
C317,C954,C964,C990,C996,C997,C1008	2203-003054	C-CHIP,9pF,5%,50V,TP,1005
C341	2203-005050	C-CHIP,1.8pF,5%,50V,TP,1005
C210,C528,C603,C644	2203-005054	C-CHIP,4.7pF,5%,50V,TP,1005
C100,C102,C106,C107,C117,C126,C134,C141,C201,C204,C205 C206,C214,C254,C258,C259,C260,C261,C358,C363,C372,C500 C608,C618,C634,C851,C853,C855,C869,C874,C901,C902,C903 C904,C905,C961,C971,C972,C973,C974,C1005	2203-005061	C-CHIP,100nF,+80-20%,16V,TP,1005

REFERENCE	SEC.CODE	DESCRIPTIONS
C170,C171,C172,C173,C257,C364,C533,C534,C536,C638 C669,C800,C830,C831,C872	2203-005065	C-CHIP,1uF,+80-20%,10V,TP,1608
C177,C342,C645	2203-005158	C-CHIP,2.2pF,5%,50V,TP,1005
C629	2203-005195	C-CHIP,10nF,5%,25V,TP,3216
C349	2203-005234	C-CHIP,1.2pF,5%,50V,TP,1005
C602,C646	2203-005444	C-CHIP,3pF,5%,50V,TP,1005
C178,C179,C180,C181	2203-005480	C-CHIP,33nF,10%,10V,TP,1005
C957	2203-005481	C-CHIP,47nF,10%,10V,TP,1005
C365,C616	2203-005562	C-CHIP,10uF,+80-20%,10V,TP,3216
C108,C131,C139,C200,C211,C262,C333,C359,C360,C433 C435,C531,C600,C601,C605,C607,C612,C615,C620,C622 C626,C630,C636,C801,C828,C850,C852,C854,C859,C870 C979,C1006,C1007	2203-005607	C-CHIP,10nF,10%,16V,TP,1005
C464,C871	2404-001083	Cap-Tantal,220uF,6.3V,20%,TP,7125
C203	2404-001086	Cap-Tantal,4.7uF,6.3V,20%,TP,2012
C103,C104,C805,C806,C816,C817,C826,C827,C832,C845 C860,C861,C868	2404-001105	Cap-Tantal,10uF,6.3V,20%,TP,2012
C873	2404-001152	Cap-Tantal , 220uF,20%,6.3V
C953	2404-001162	Cap-Tantal,47uF
C253	2404-001164	Cap-Tantal, 10uF,20%,16V
L126,L128	2703-000217	Inductor,470uH/10%,2012
L127,L129	2703-001071	Inductor,330uH/10%,2012
L302	2703-001172	Inductor,100nH/5%,1608
L401	2703-001174	Inductor,33nH/5%,1608
L607	2703-001178	Inductor,3.3nH/0.3nH,1005
L327	2703-001179	Inductor,10nH/5%,1005
L175	2703-001290	Inductor,2.7nH/0.3nH,1608
L502,L503	2703-001308	Inductor,68nH/5%,1608
L177,L308,L600	2703-001409	Inductor,12nH/10%,1005
L320	2703-001544	Inductor,39nH/5%,1608
L250	2703-001595	Inductor,47nH/5%,1005
L300	2703-001685	Inductor,82nH/5%,1608
L326,L402	2703-001708	Inductor,5.6nH/5%,1005
L800	2703-001716	Inductor,22uH,1608
L323,L500	2703-001722	Inductor,18nH/5%,1005
L321,L322,L405,L406,L504,L505	2703-001723	Inductor,33nH/5%,1005
L507	2703-001726	Inductor,27nH/5%,1005
L324,L328,L329,L602	2703-001727	Inductor,22nH/5%,1005
L604	2703-001728	Inductor,1.5nH/0.3nH,1005
L301,L303,L501	2703-001732	Inductor,56nH/5%,1608
L305,L310	2703-001733	Inductor,8.2nH/5%,1005
L309,L325	2703-001734	Inductor,6.8nH/5%,1005

REFERENCE	SEC.CODE	DESCRIPTIONS
L306,L319	2703-001735	Inductor,3.9nH/10%,1005
L307,L603,L606	2703-001737	Inductor,2.7nH/0.3nH,1005
L251	2703-001740	Inductor,10uH/20%,1608
L601	2703-001794	Inductor,120nH/2%,1608
L318	2703-001798	Inductor, 2.2nH/5%,1005
L801	2703-001904	Inductor,4.7mH
X201	2801-003847	Crystal
X600	2806-001190	DUAL VCO,1171~1216MHz,3V,8mA,TP
X501	2806-001194	DCS TX VCO
X500	2806-001199	GSM TX VCO
X601	2809-001220	VCTCXO-13MHz
F305	2903-001203	Ceramic Filter
F303	2904-001093	Filter-SAW,1842.5MHz,75MHz
F300	2904-001146	Filter-SAW-AV,246MHz
F301	2904-001147	Filter-SAW-AV,942.5MHz
F304	2904-001170	DCS Filter
F302	2904-001175	GSM RX SAW
U401	2909-001086	ANTENNA SWITCH,942.5MHz,897.5MHz
F200,F201	3301-001208	Core-Ferrite Bead
J100	3709-001121	SIM CONNECTOR,6P,2.54mm,SMD-S
M950	3710-001105	CONNECTOR-SOCKET,2P,1.27mm,SMD-S
J176	3710-001302	I/F Connector,18P,0.5mm
J151	3710-001428	BTB Connector,24P,0.5mm
J901	3722-001380	Earphone jack,6P
U405	4709-001174	Directional Coupler,890-915/1710-1785MHz
R360,R359,R604,R615,R632,R989,R990,C130,C138,C176 C370,C380,C367,C369,C535,C643,C962,C963,L176,L311,L605		"SOT,NC"
C863	4302-001081	BATT/CAP250uAH 3.3V
J180	GH07-00023A	LCD
motor	GH31-10004A	Vibrator motor
W176	GH39-00041A	Semirigid Cable
PCB	GH41-00065A	SGH-2400 PCB
	GH42-00038A	ANTENNA
	GH59-00067A	KEYPAD ASS'Y
A176	GH71-00156A	ANTENNA CLIP
JIG	GH80-10508A	SGH-2400 TEST JIG
CABLE	GH39-30532A	SGH-2400 TEST JIG CABLE
TA	GH44-30549A	SGH-2400 TRAVEL ADAPTOR(EUROPE)
TA	GH44-30547A	SGH-2400 TRAVEL ADAPTOR(U.K)
TA CABLE	GH39-10504A	SGH-2400 TA CABLE
CLA	GH44-00040A	SGH-2400 CLA
DTC	GH44-00090A	DESK TOP CHARGE

REFERENCE	SEC.CODE	DESCRIPTIONS
SLIM BATTERY		500mAh (GREY)
SLIM BATTERY		500mAh (BLACK)
STANDARD BATTERY	GH43-00143A	750mAh (GREY)
STANDARD BATTERY	GH43-00143B	750mAh (BLACK)
EXTENDED BATTERY		1000mAh (GREY)
EXTENDED BATTERY		1000mAh (BLACK)
ULTRA EXTENDED BATTERY		1600mAh (GREY)
ULTRA EXTENDED BATTERY		1600mAh (BLACK)
DATA KIT	GH96-00774A	SGH-2400 DATA KIT
HFK		HANDS FREE KIT
EAR PHONE	GH96-00830A	EAR PHONE

3 Block Diagrams

3-1 Main RF

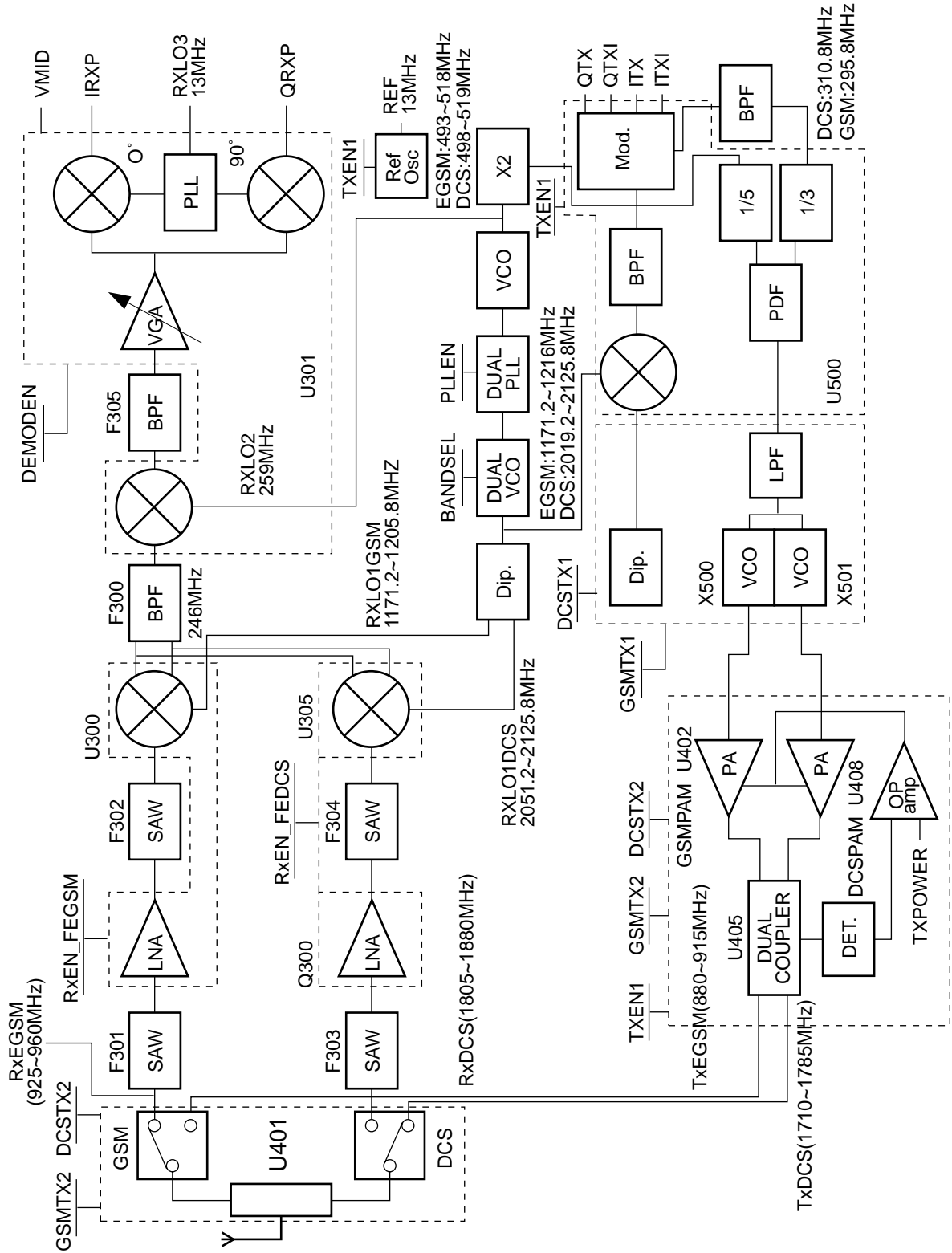

3-2 Main Base Band

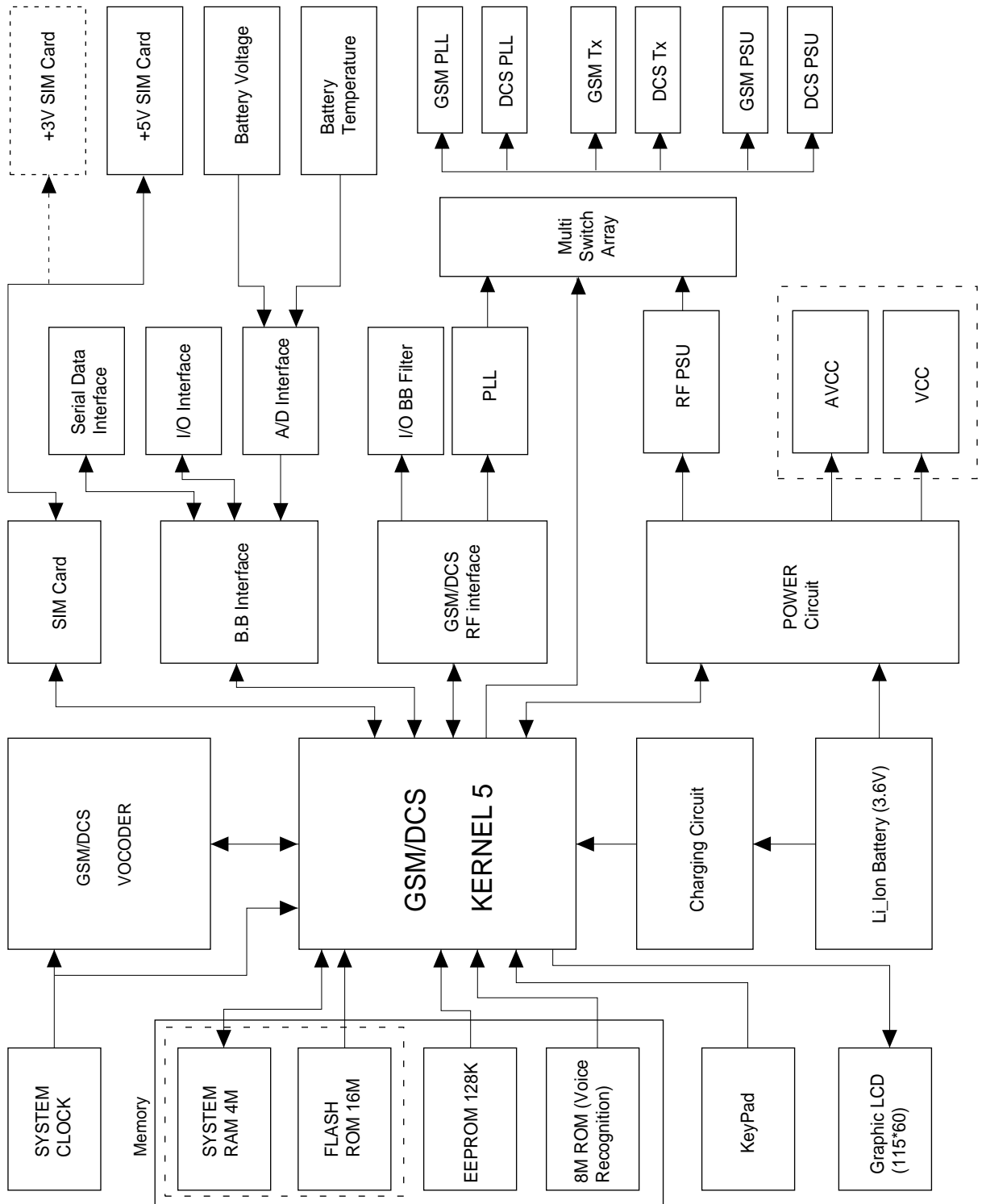

3-3 Travel Adapter

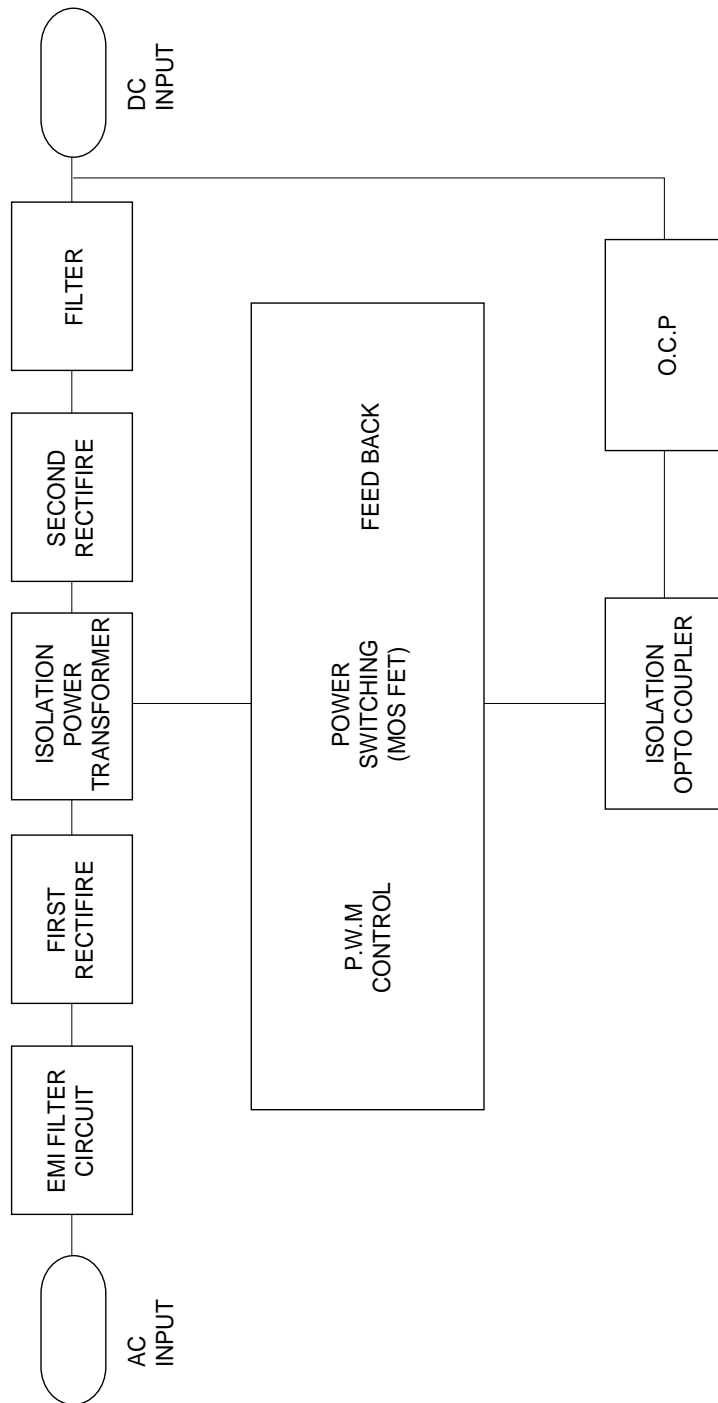

3-4 Desk Top Charger

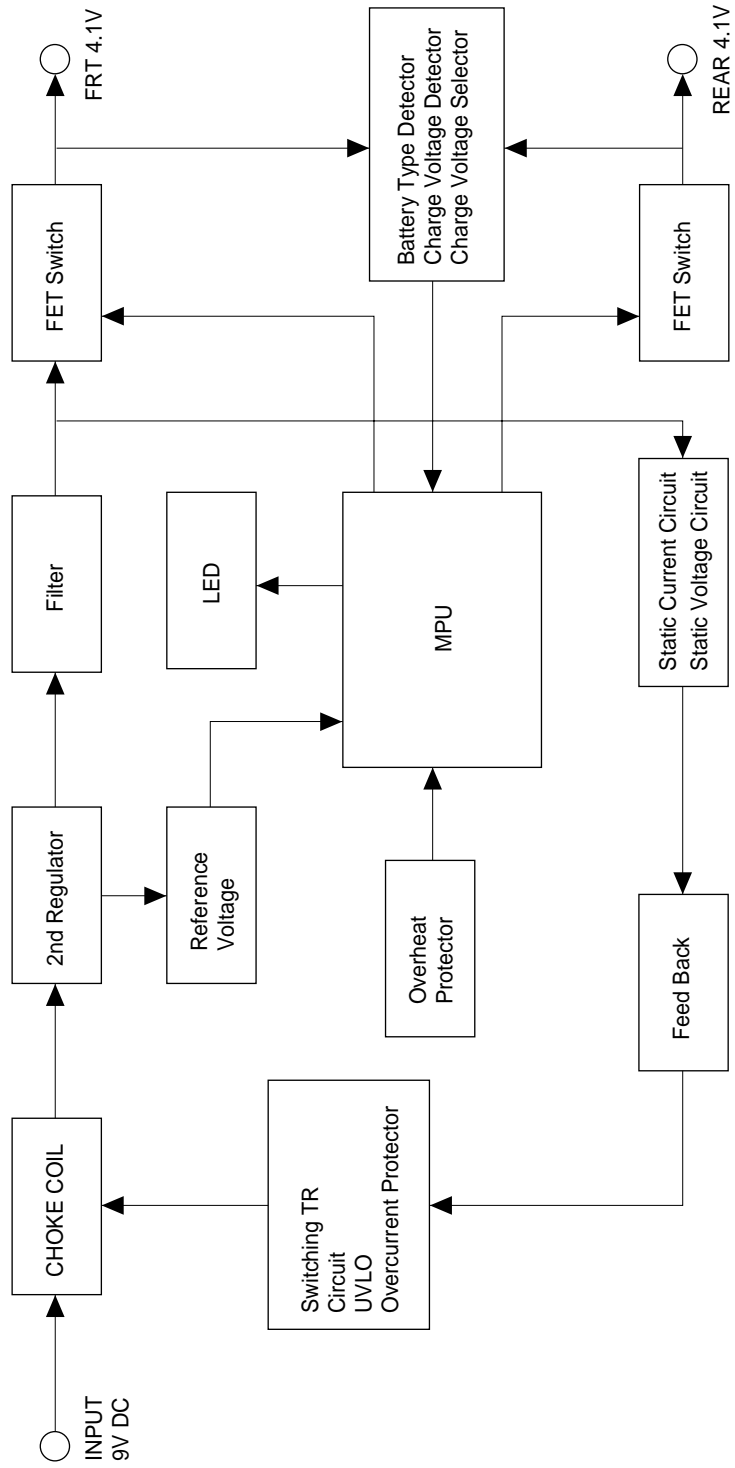

4. PCB Diagrams

4-1 Main Top

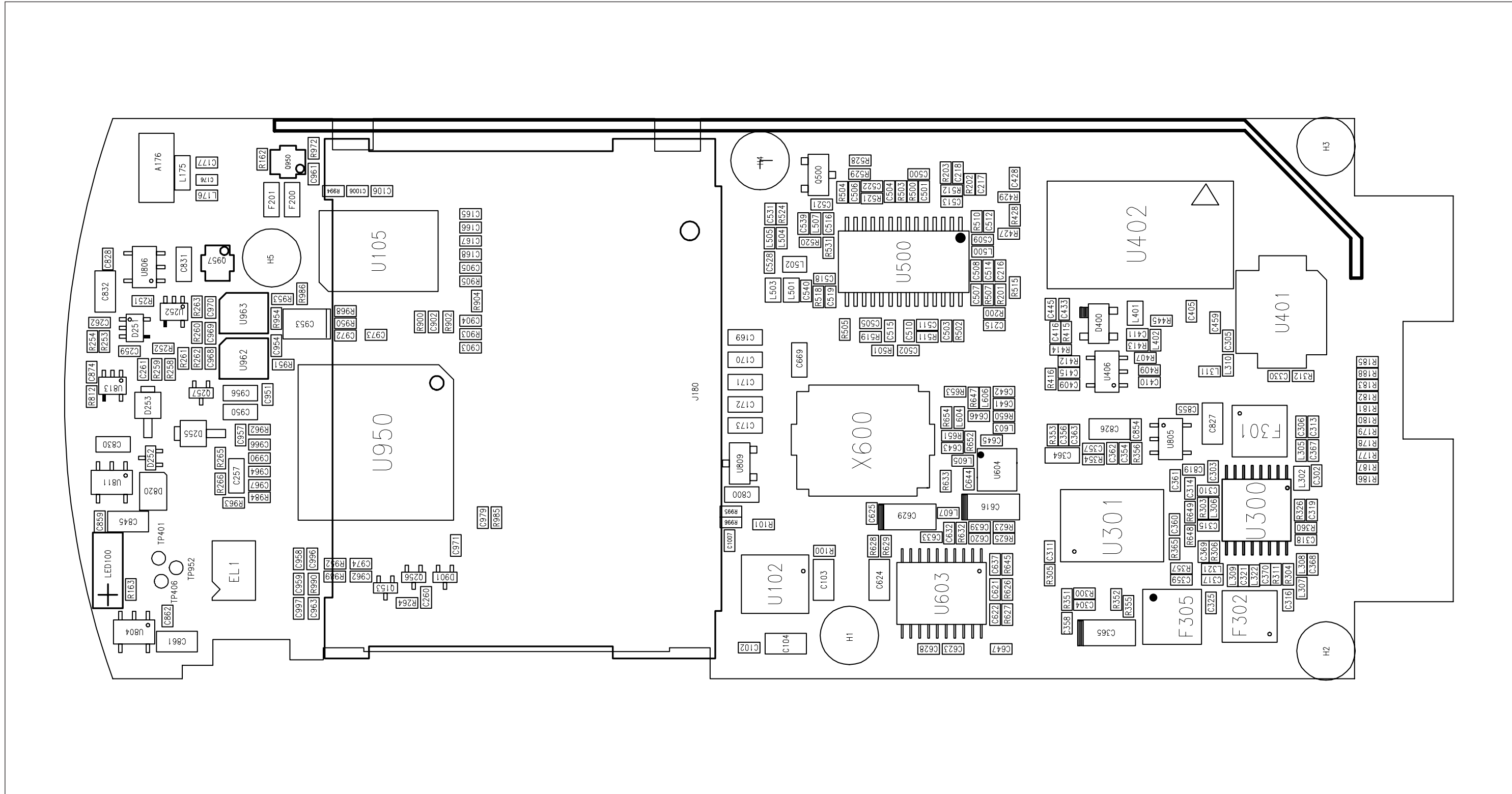

4-2 Main Bottom

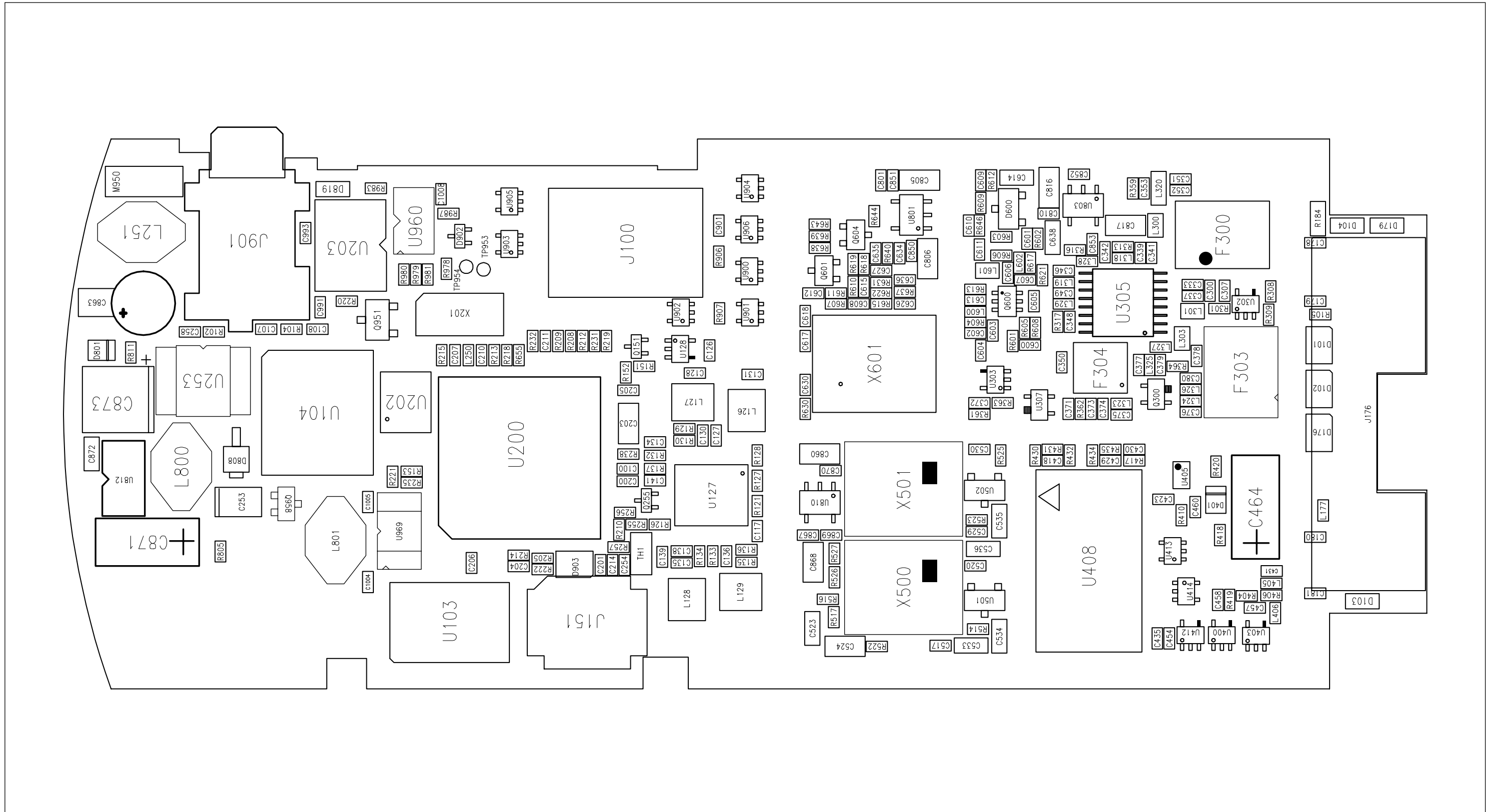

5. Schematic Diagrams

5-1 Top Level

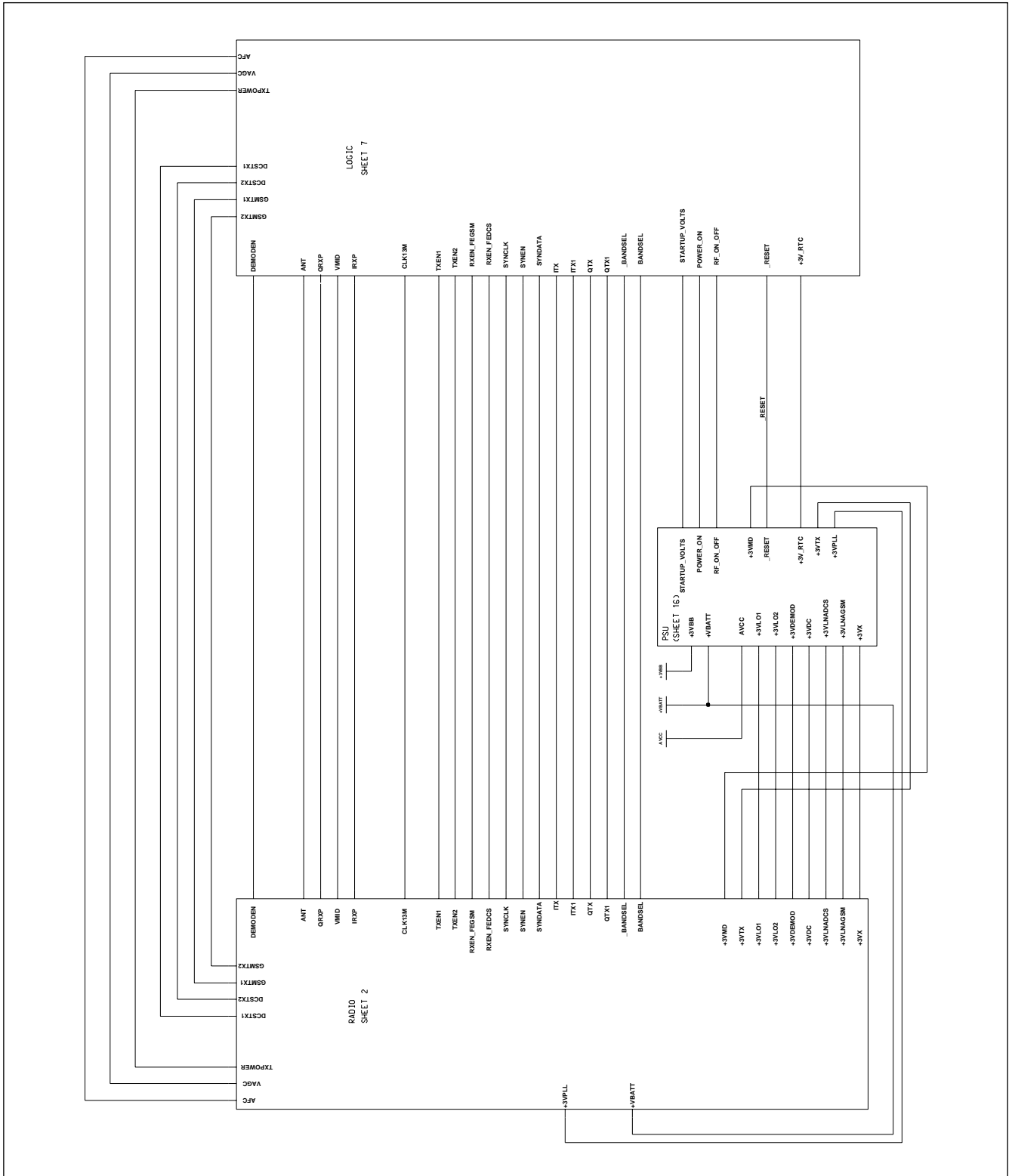

5-2 Radio

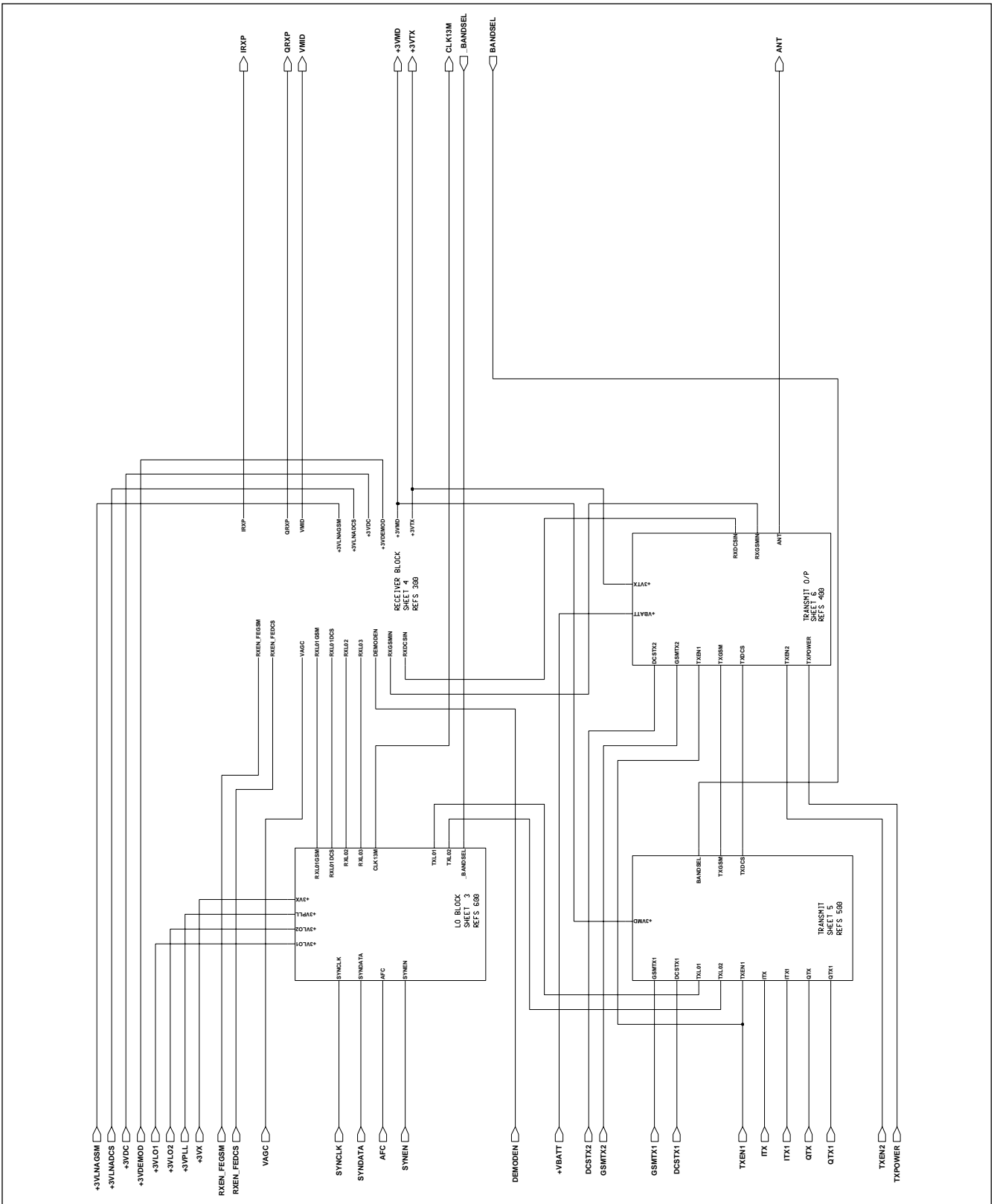

5-3 Main VCO and Local

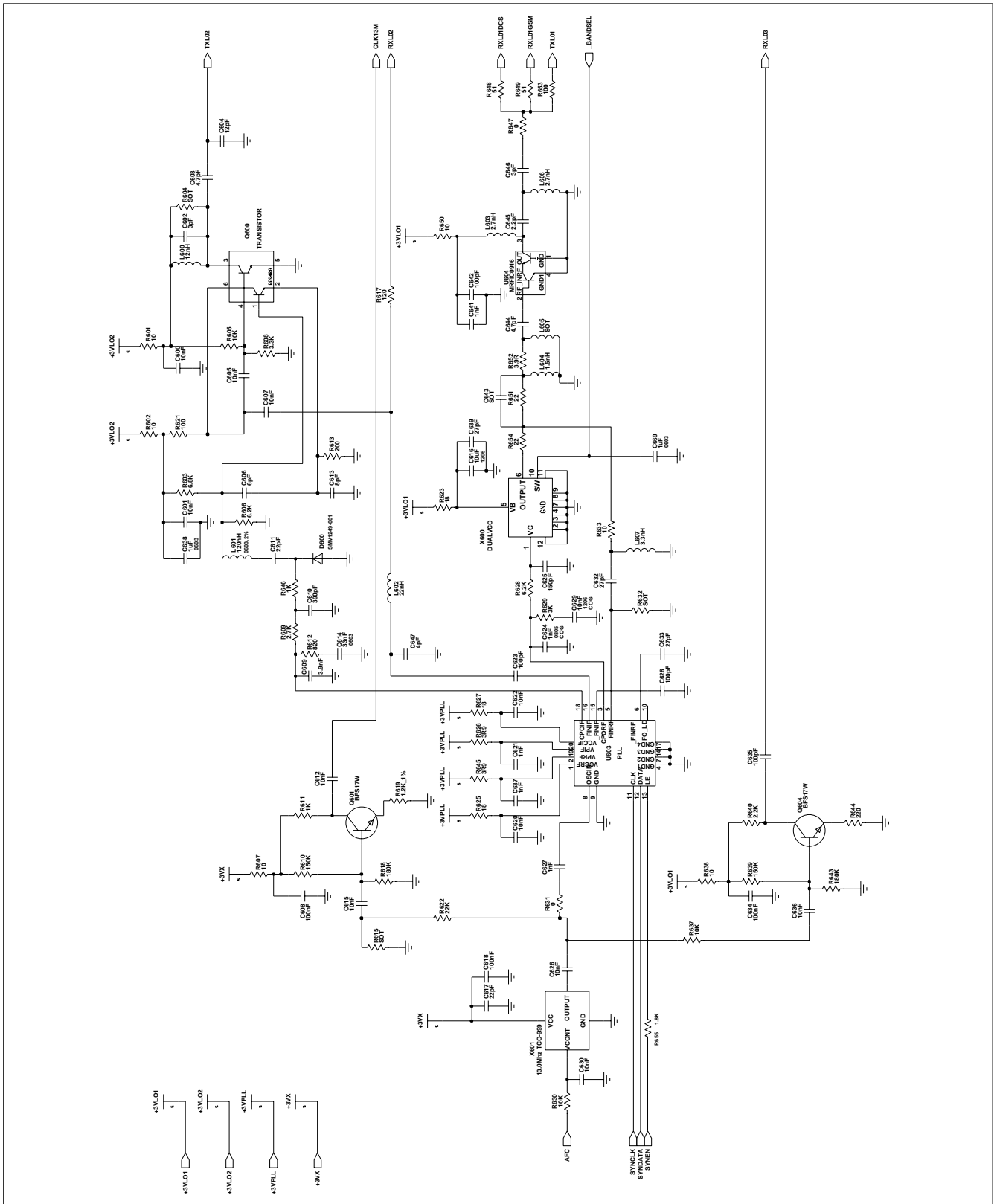

5-4 Receiver

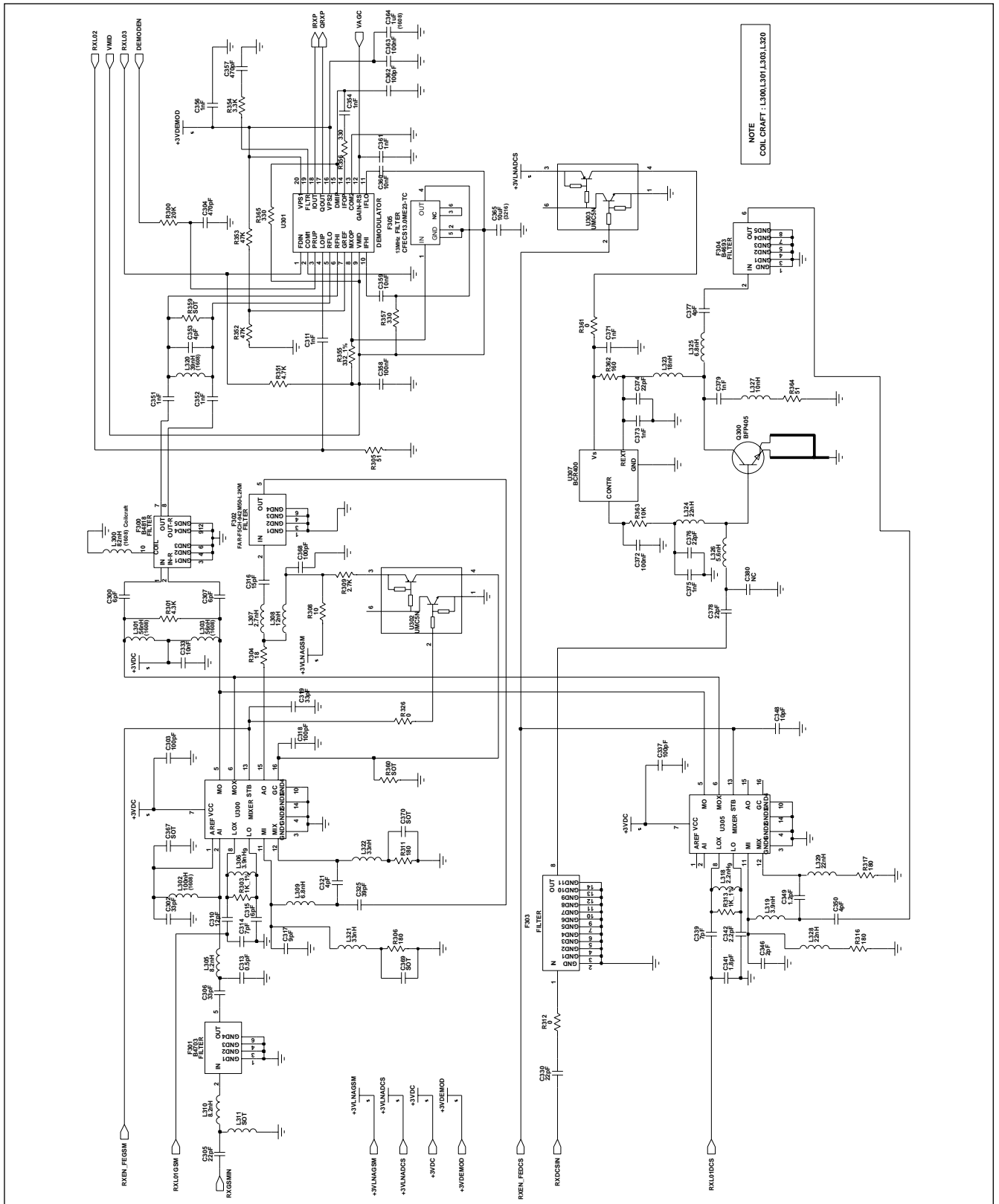

5-5 Modulator & Tx Vco

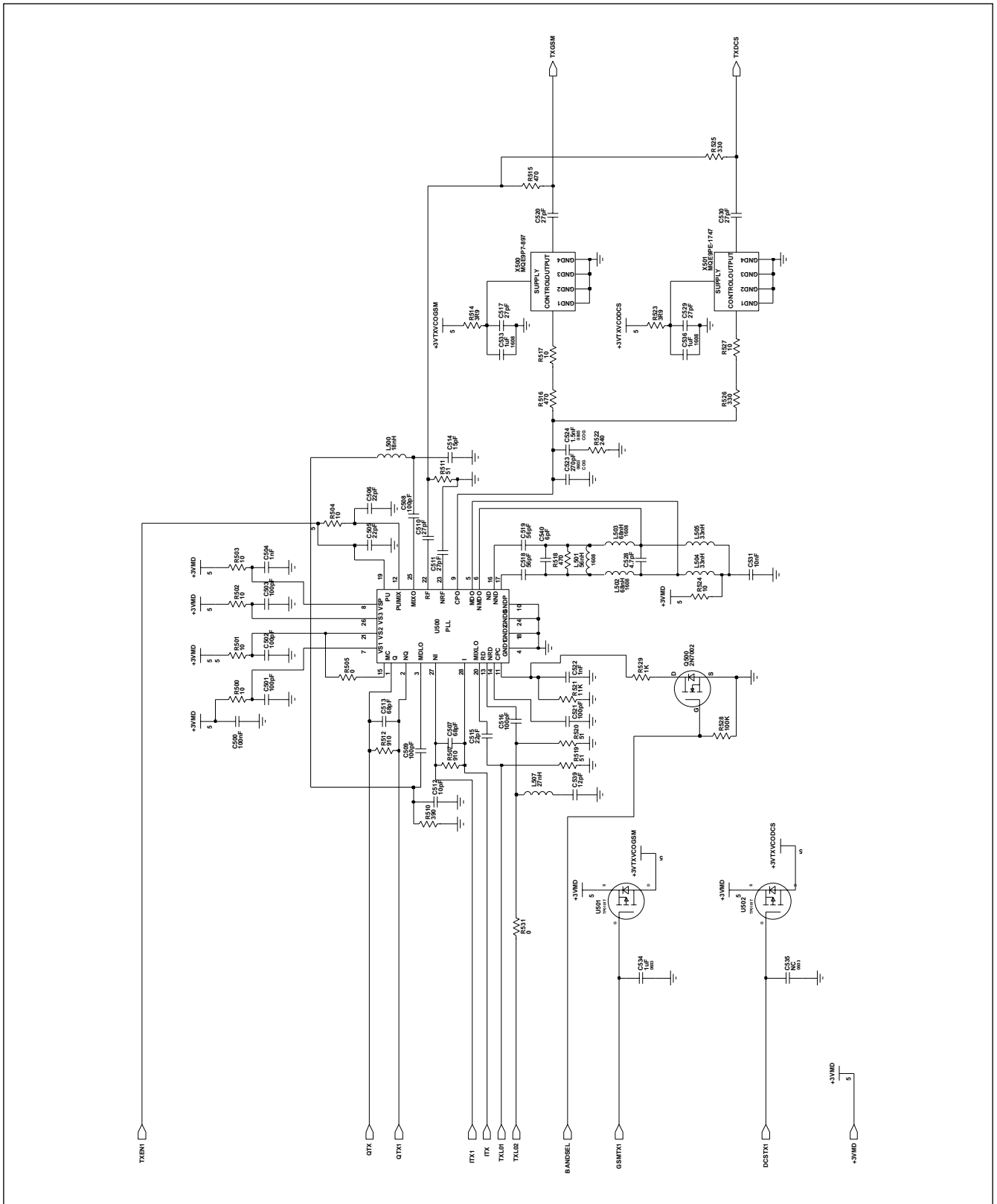

5-6 Transmit Output Stage

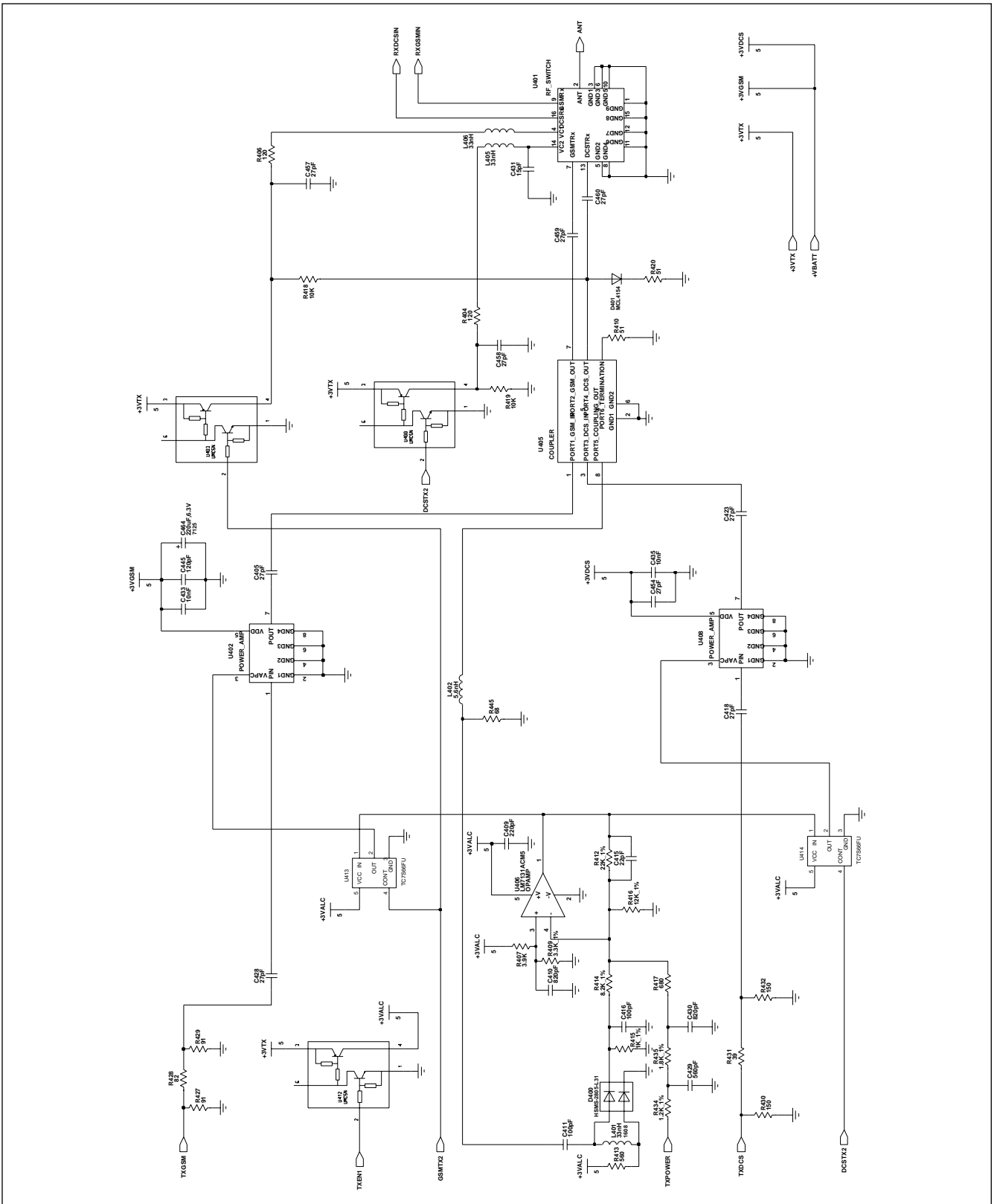

5-7 Base Band Block

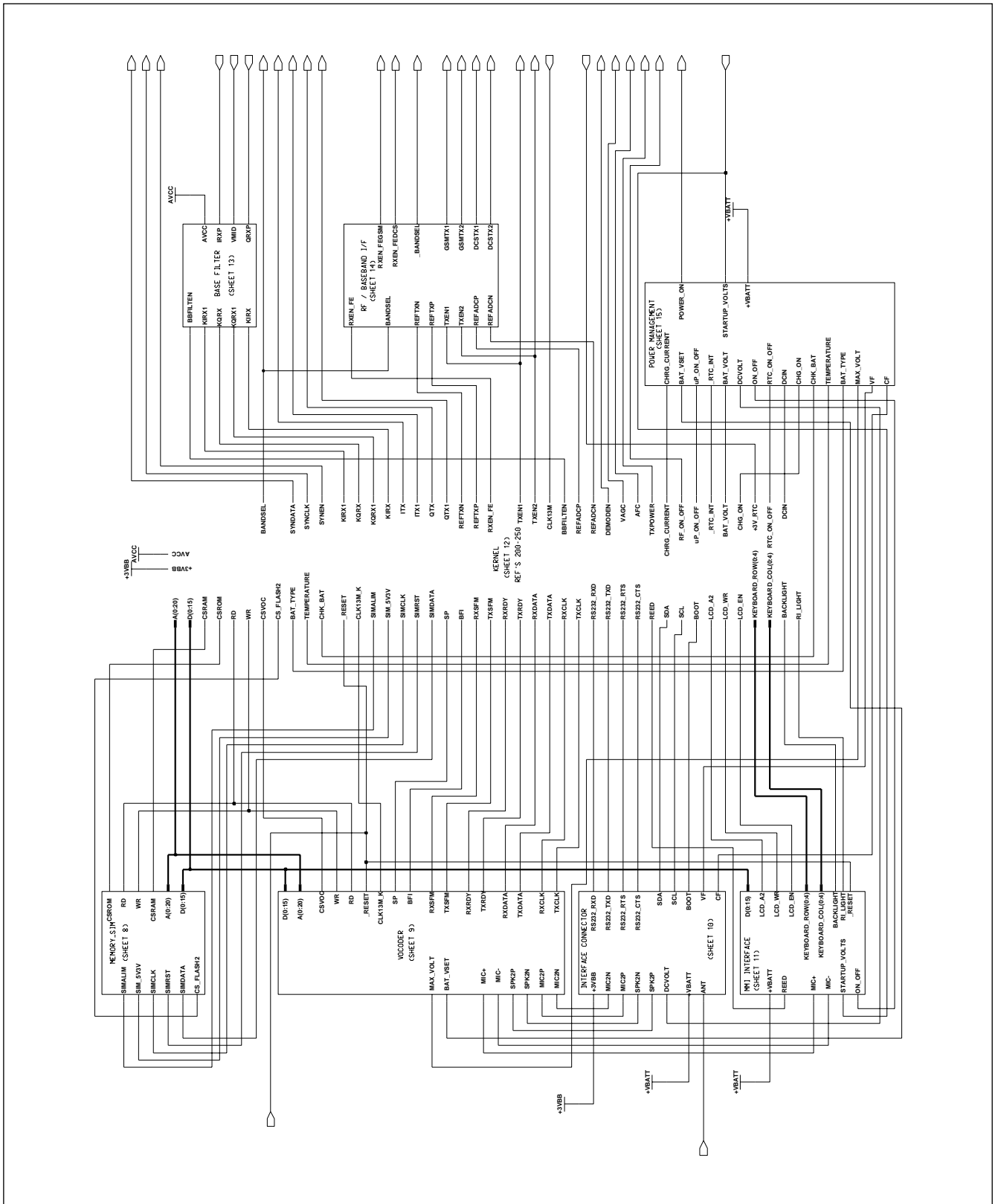

5-8 Memory & SIM Schematic

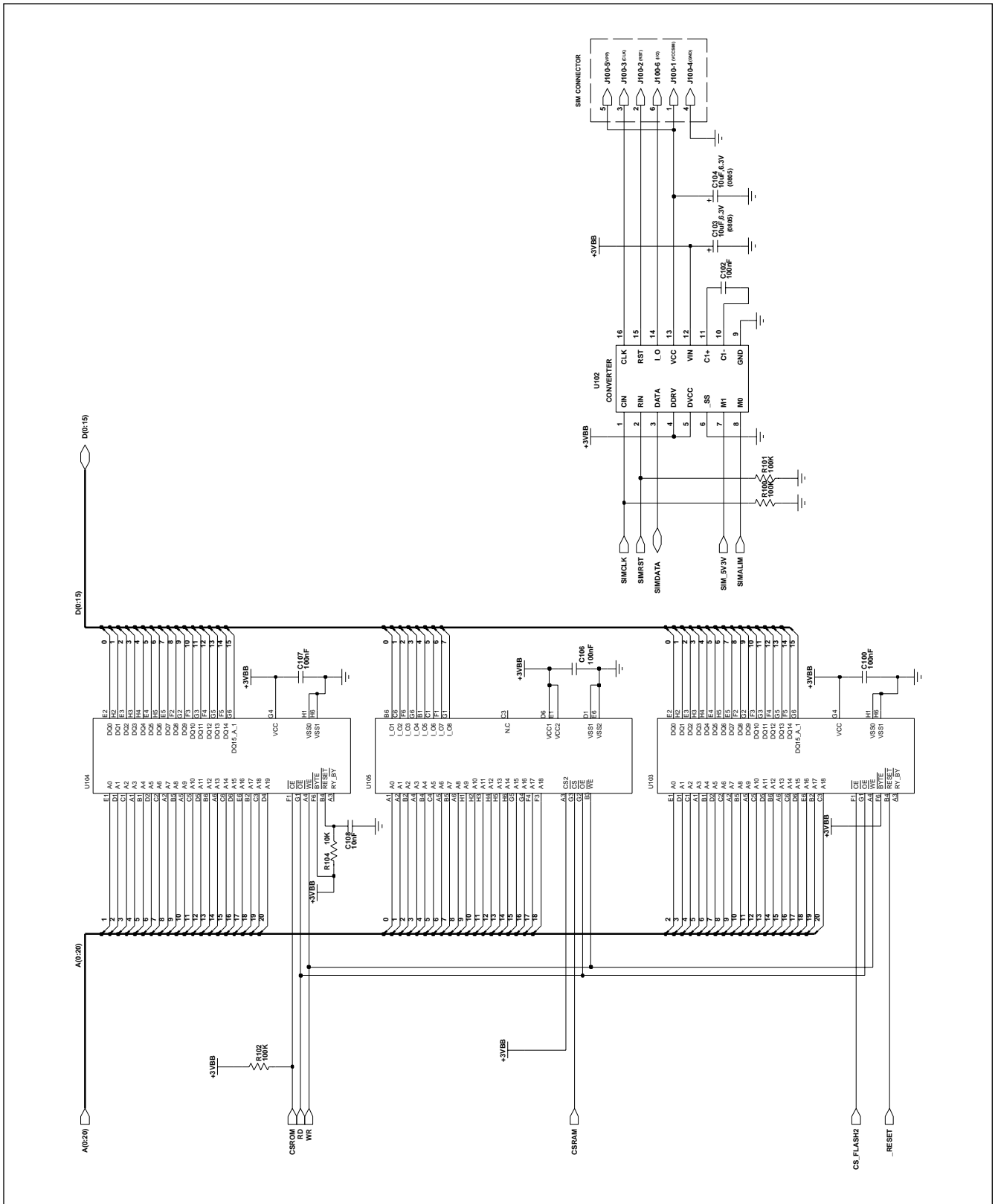

5-9 Vocoder

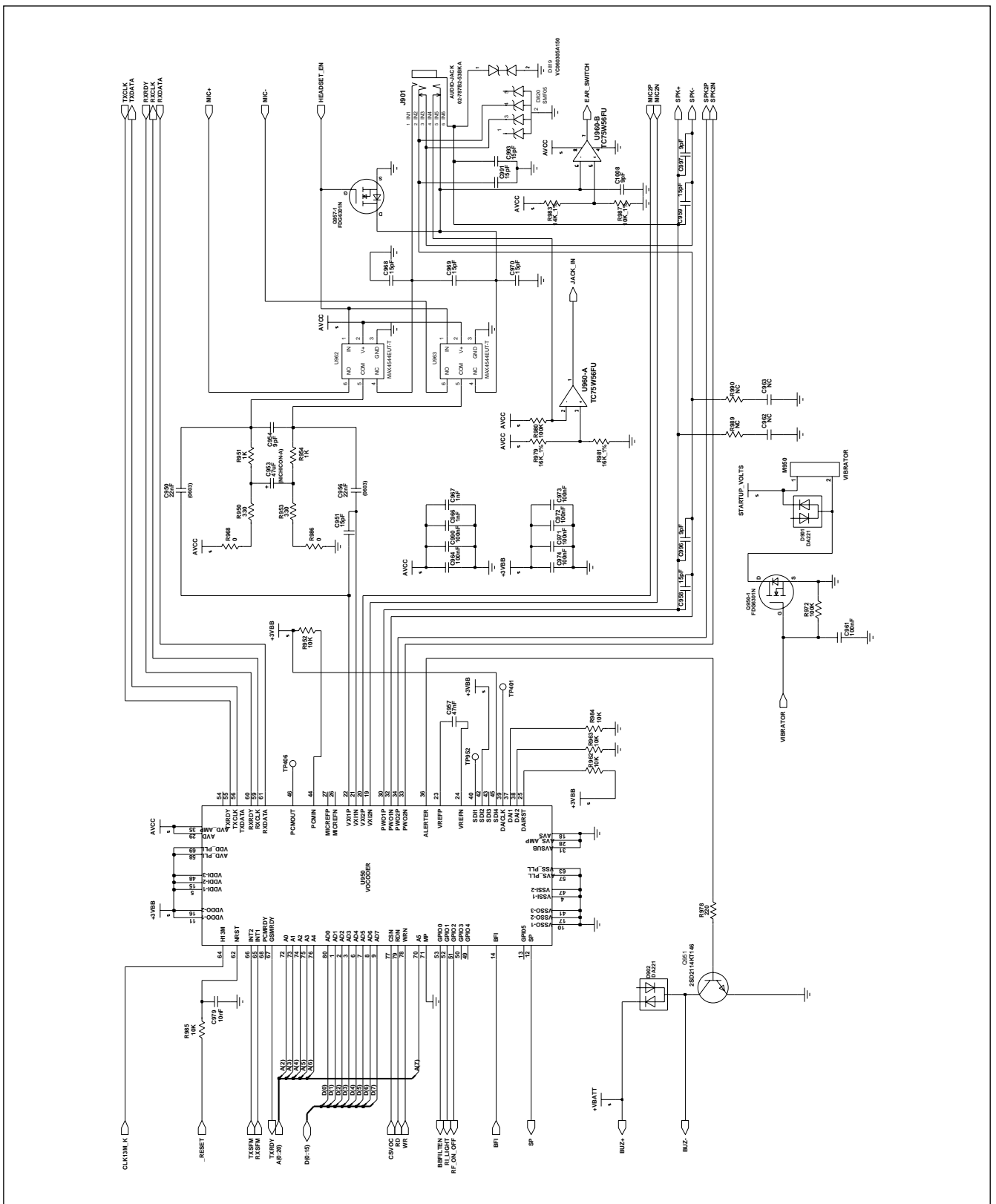

5-10 Interface Connector

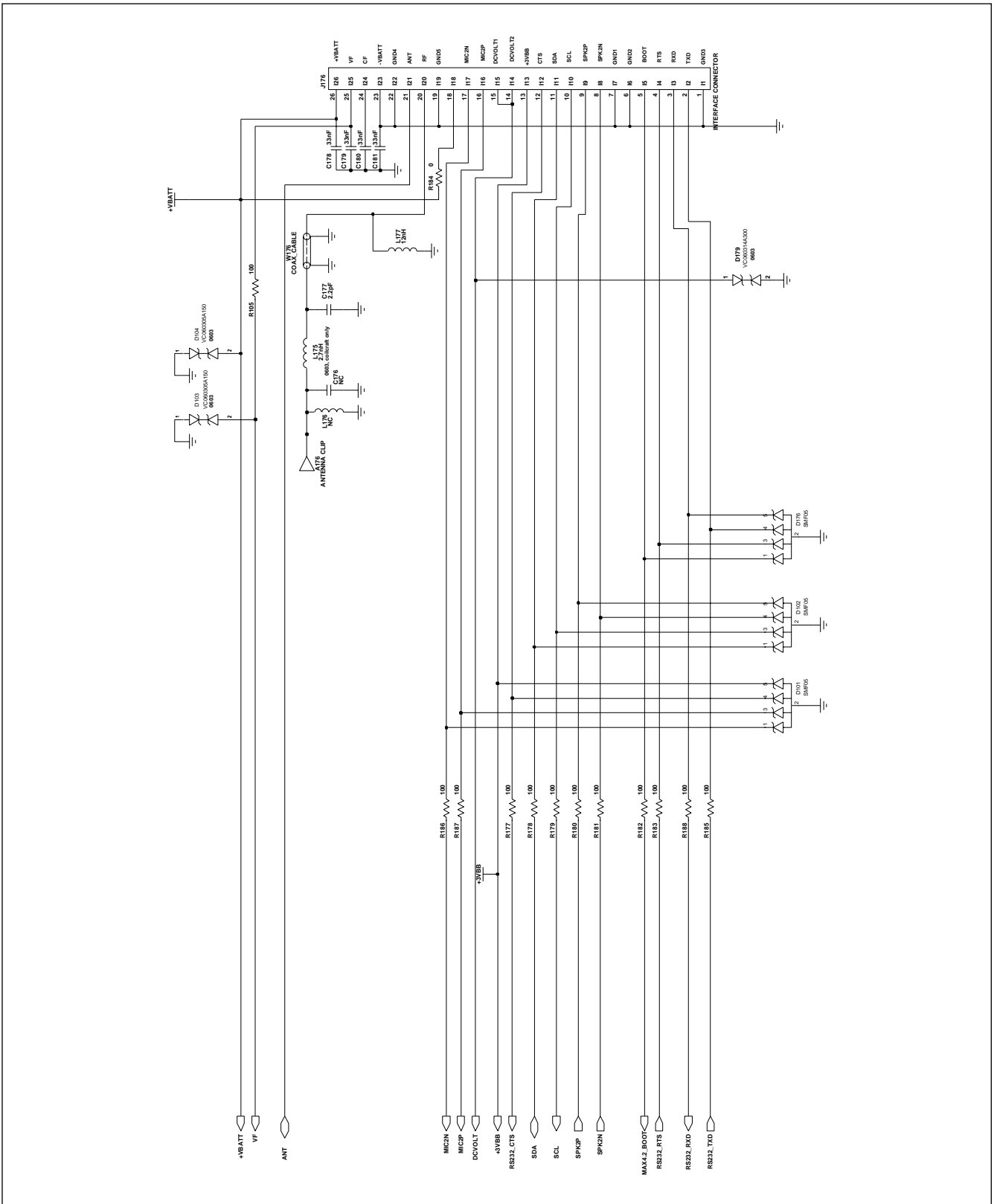

5-11 MMI Interface

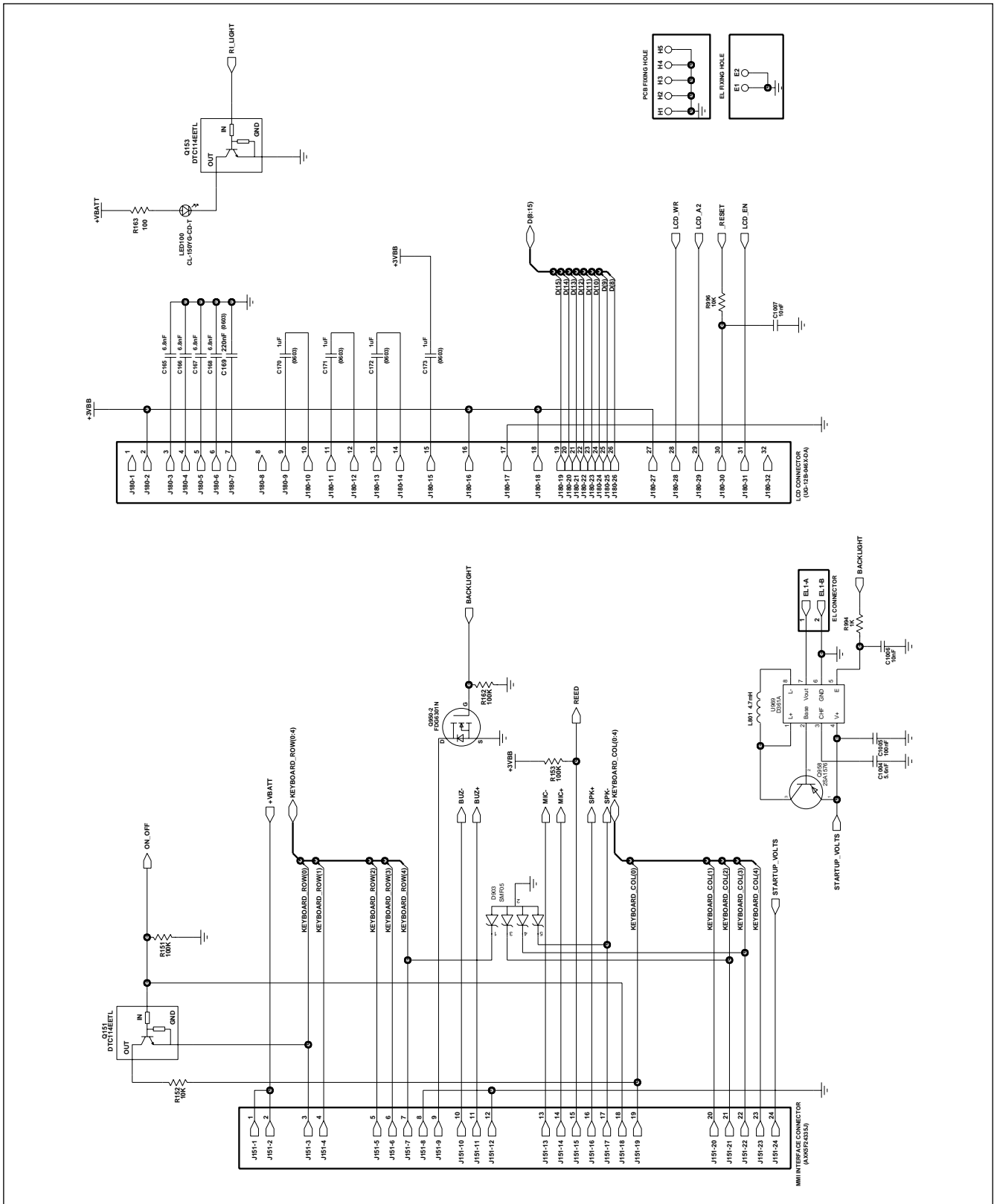

5-12 Kernel

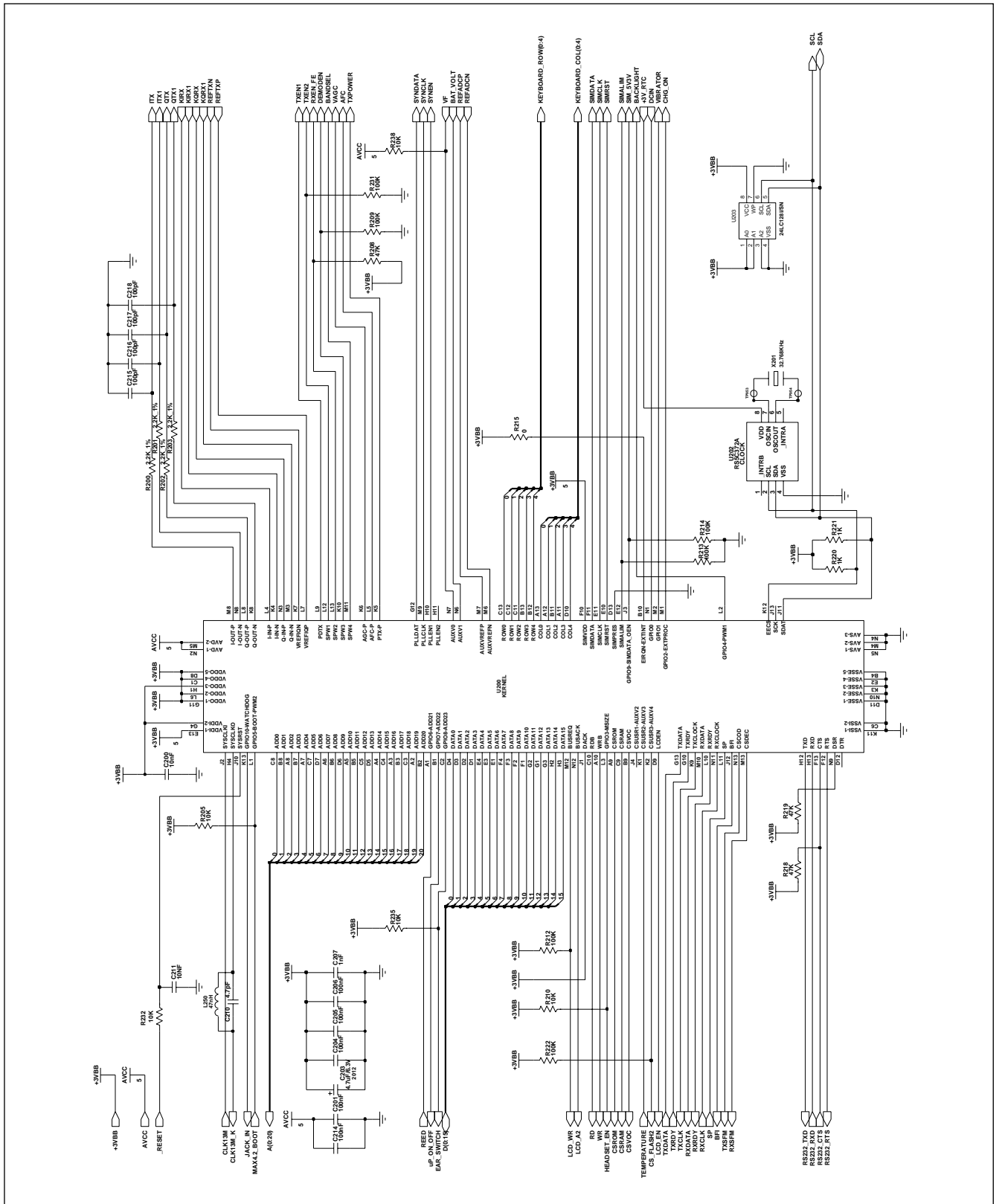

5-13 Baseband Filters

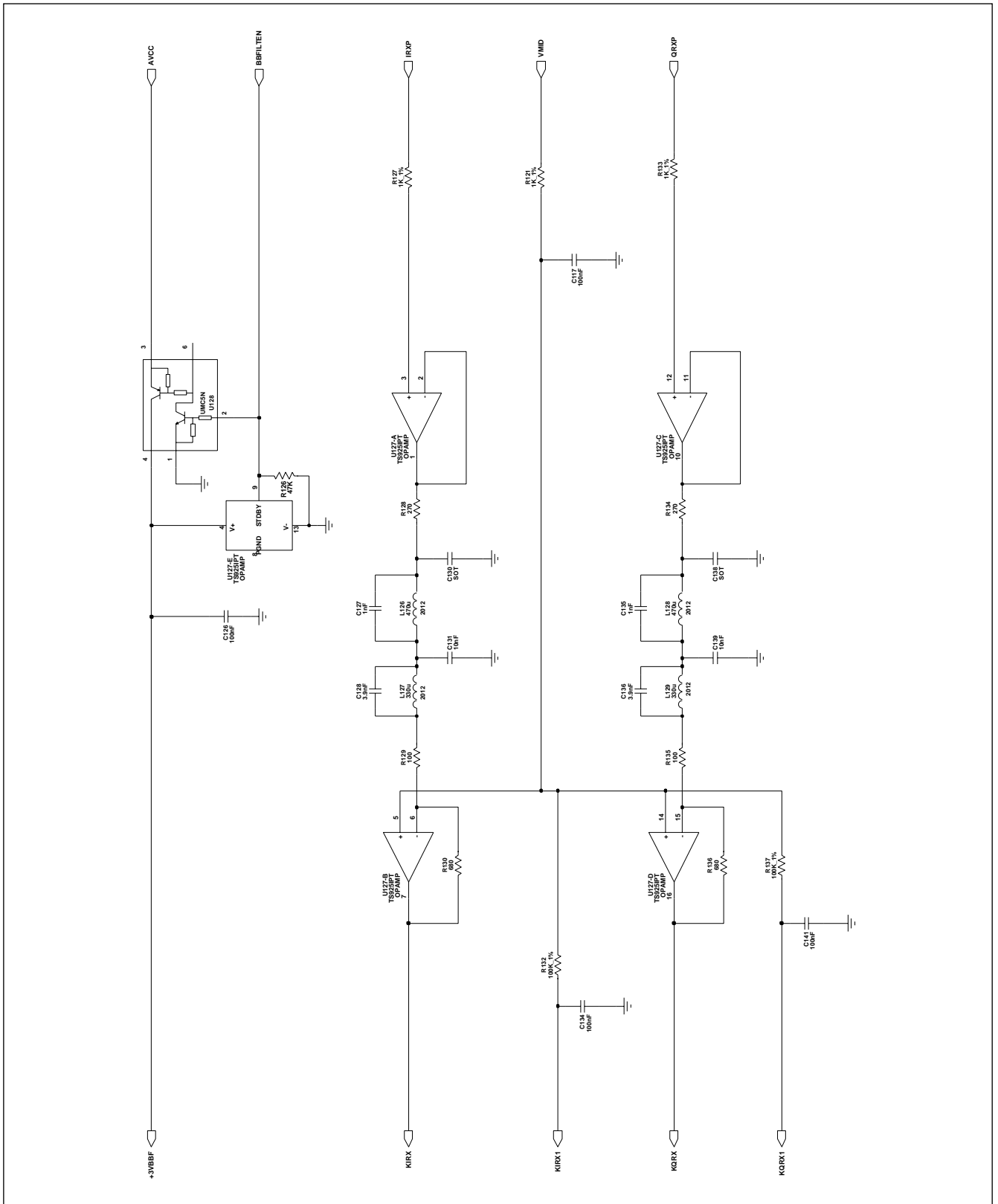

5-14 Control Logics

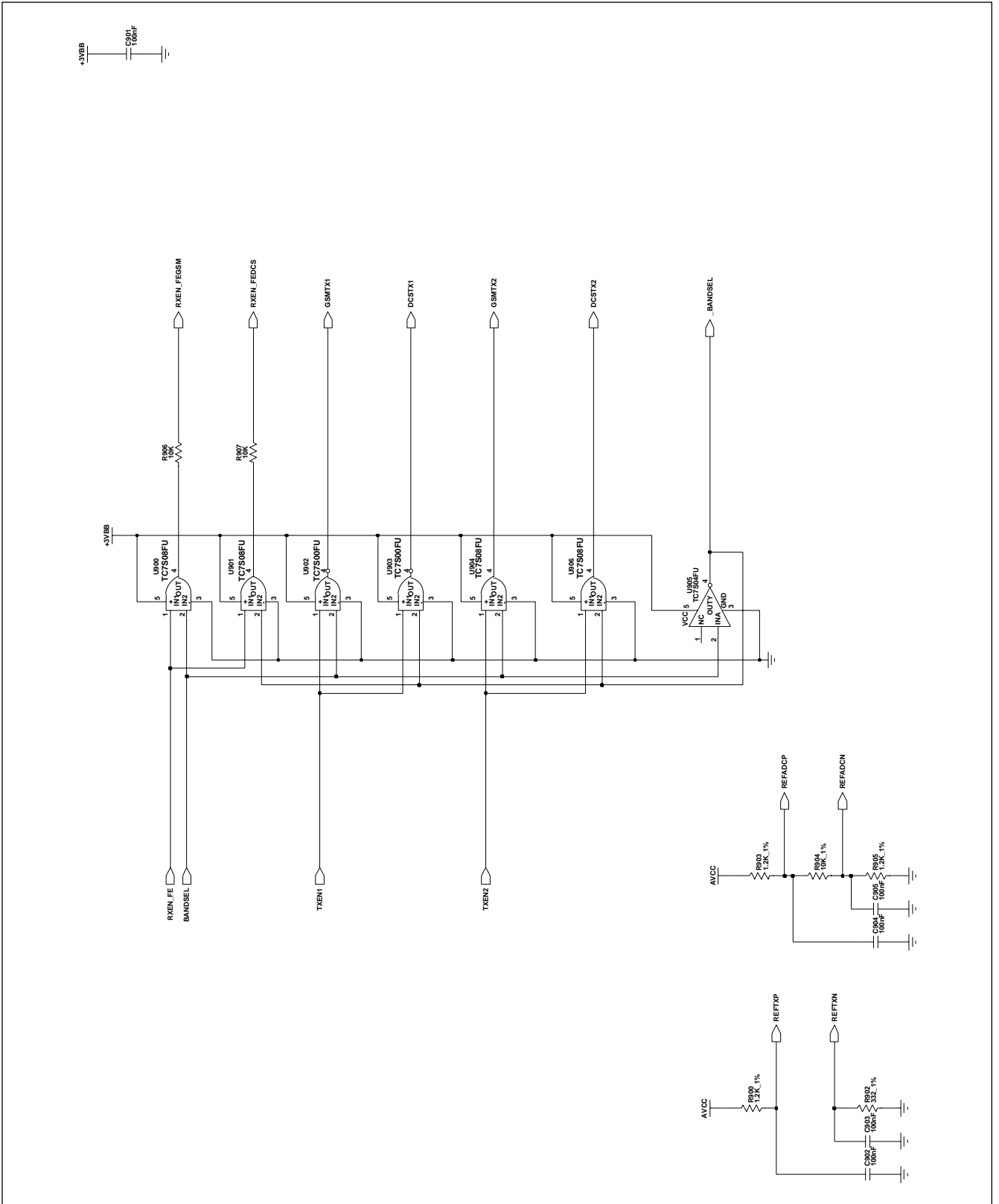

5-15 Power Management

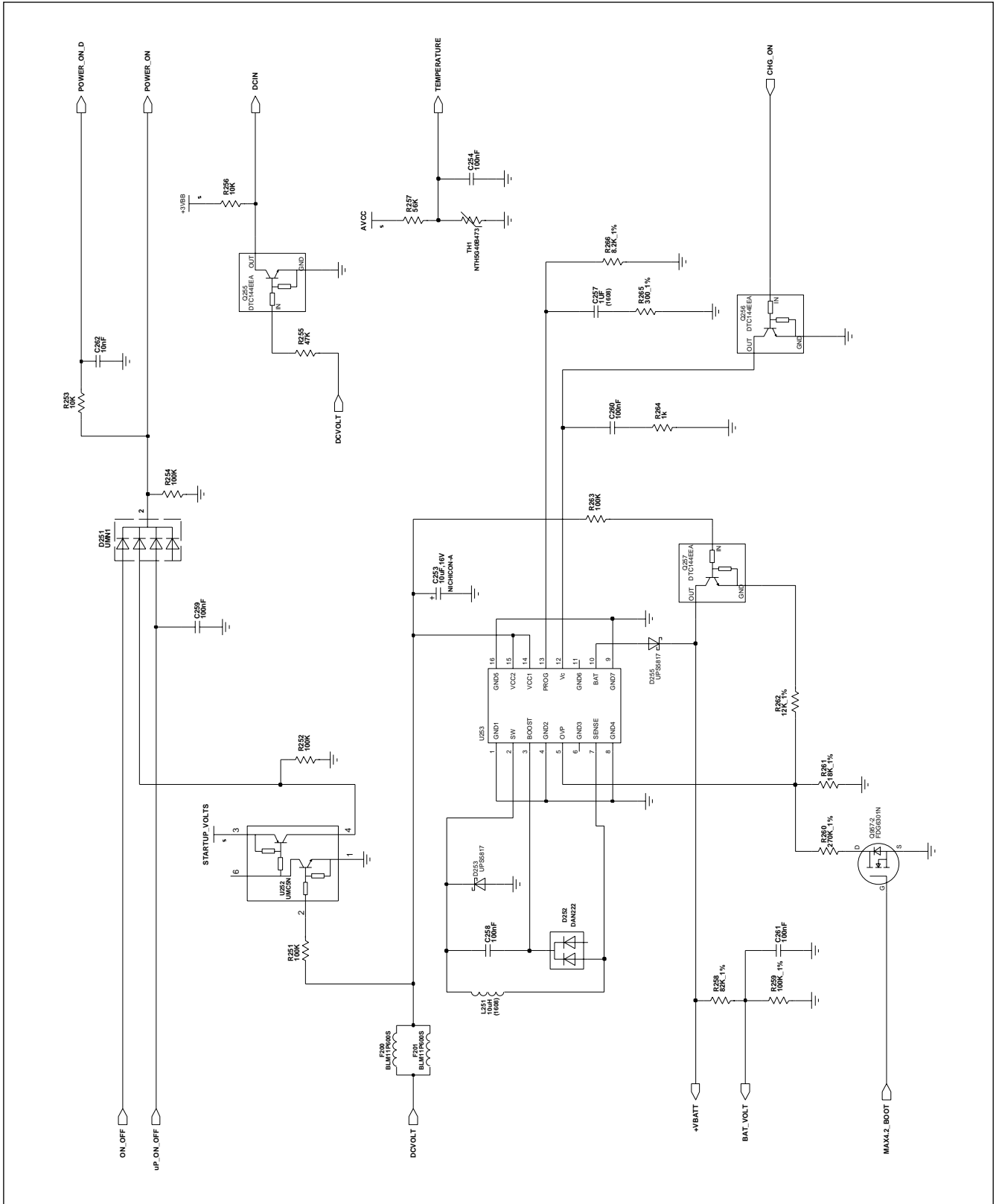

5-16 Power Supply Units

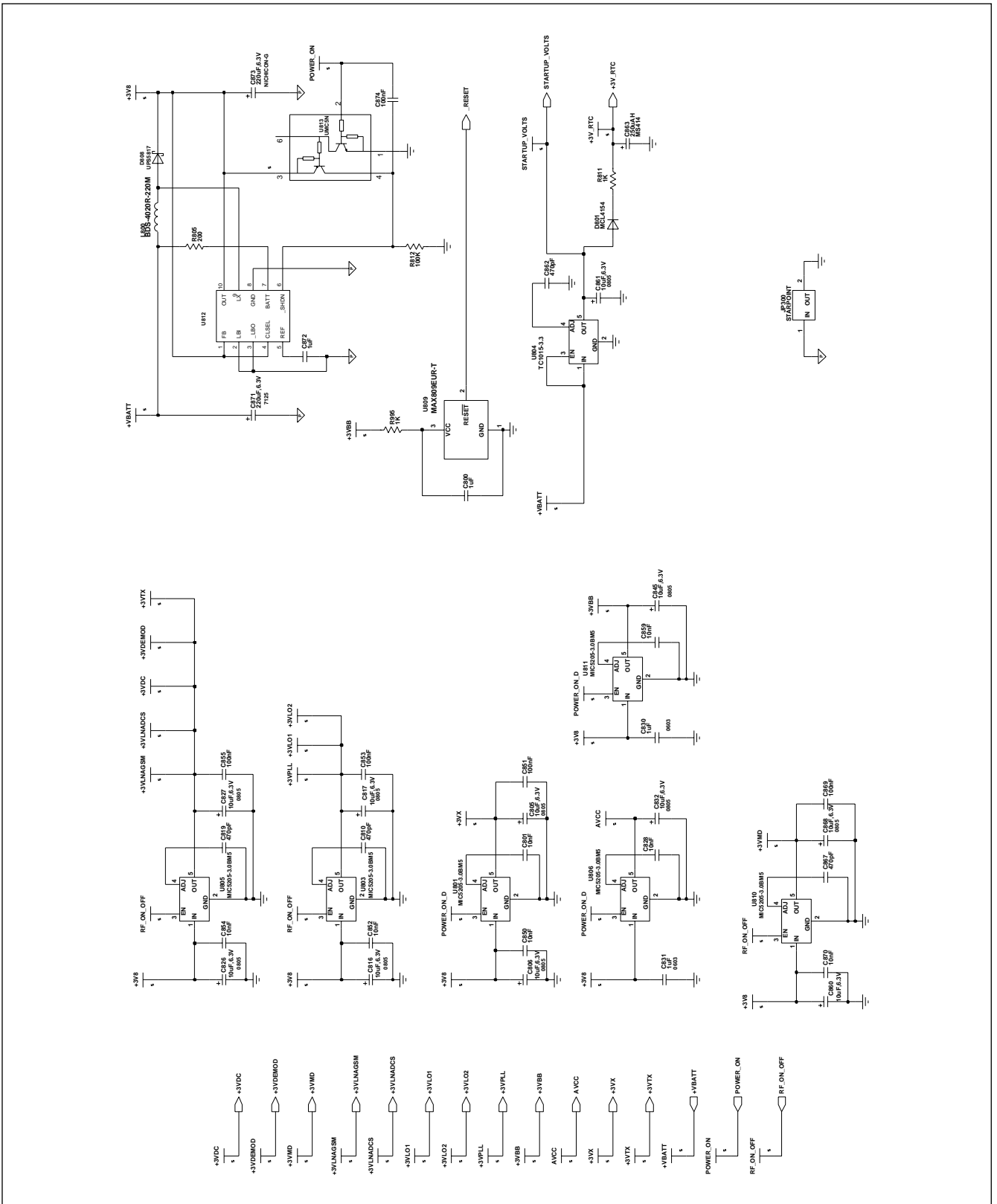



ELECTRONICS