

# SCHEM, IRB, M88

1. ALL RESISTANCE VALUES ARE IN OHMS, 0.1 WATT +/- 5%.
2. ALL CAPACITANCE VALUES ARE IN MICROFARADS.
3. ALL CRYSTALS & OSCILLATOR VALUES ARE IN HERTZ.

REV	ZONE	ECN	DESCRIPTION OF CHANGE	CK APPD	ENG APPD
			DATE	DATE	DATE
A		554173	PRODUCTION RELEASED	12/18/07	?

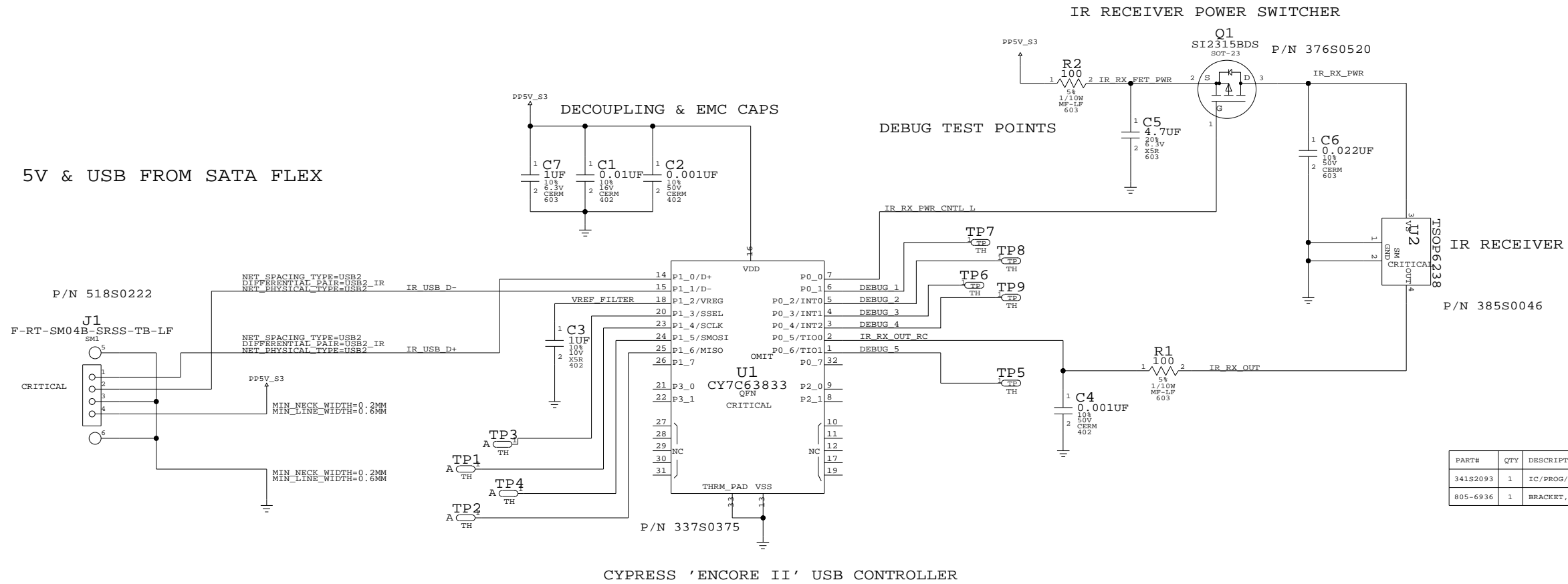

PART#	QTY	DESCRIPTION	REFERENCE DESIGNATOR(S)	CRITICAL	BOM OPTION
341S2093	1	IC/PROG/I/R F/W,CY7C6383	U1	CRITICAL	
805-6936	1	BRACKET, MOUNTING PHASER, M9	BR1	CRITICAL	

A		
DATE	DESIGNER	PRODUCTION RELEASED
08/22/07	NMARTIN	BRANCHED FROM M76

PART#	QTY	DESCRIPTION	REFERENCE DESIGNATOR(S)	CRITICAL	BOM OPTION
051-7500	1	SCHEM, IRB, M88	SCH	CRITICAL	
820-2309	1	PCBF, IRB, M88	PCB	CRITICAL	
630-9181	1	PCBA, IRB, M88	BOM		OMIT
000-0041	1	PLACEHOLDER FOR EEE/CCC INFO	[EEE:XPR]	CRITICAL	

DIMENSIONS ARE IN MILLIMETERS		METRIC		APPLE INC.	
XX :	_____			NOTICE OF PROPRIETARY PROPERTY THE INFORMATION CONTAINED HEREIN IS THE PROPRIETARY PROPERTY OF APPLE COMPUTER, INC. THE POSSESSOR AGREES TO THE FOLLOWING: I TO MAINTAIN THE DOCUMENT IN CONFIDENCE II NOT TO REPRODUCE OR COPY IT III NOT TO REVEAL OR PUBLISH IN WHOLE OR PART	
X.XX :	_____	DRAPTR	DESIGN CK		
X.XXX :	_____	ENG APPD	MFG APPD		
ANGLES :	_____	QA APPD	DESIGNER		
DO NOT SCALE DRAWING		RELEASE	SCALE	TITLE	
THIRD ANGLE PROJECTION 		MATERIAL/FINISH NOTED AS APPLICABLE		SIZE D	M88 IR BOARD DRAWING NUMBER 051-7500 REV. A
SHT 1 OF 1					