

1. ALL RESISTANCE VALUES ARE IN OHMS, 0.1 WATT +/- 5%.  
 2. ALL CAPACITANCE VALUES ARE IN MICROFARADS.  
 3. ALL CRYSTALS & OSCILLATOR VALUES ARE IN HERTZ.

REV	ZONE	ECN	DESCRIPTION OF CHANGE	CK APPD	ENG APPD
				DATE	DATE
A		554180	PRODUCTION RELEASED	12/18/07?	

# SCHEM, Left IO Board, M88, MBP17

## PVT: 12/14/07

PDF PAGE	CSA PAGE	CONTENTS	SYNC MASTER	DATE
1	1	Table of Contents	(MASTER)	(MASTER)
2	2	Block Diagram	(MASTER)	(MASTER)
3	4	BOM CONFIGURATION	(MASTER)	(MASTER)
4	5	Version History	(MASTER)	(MASTER)
5	8	Aliases	(MASTER)	(MASTER)
6	34	PCI-E MiniCard Connector	M75_LIO	04/10/2007
7	35	ExpressCard Connector	M75_LIO	04/10/2007
8	36	MLB I/O Board Connector	(MASTER)	(MASTER)
9	46	Left USB Ports	(MASTER)	(MASTER)
10	58	Left ALS	(MASTER)	(MASTER)
11	62	AUDIO: CODEC	M88_AUDIO	11/01/2007
12	63	AUDIO: LINE IN	M88_AUDIO	11/01/2007
13	65	AUDIO: HEADPHONE AMP	M88_AUDIO	11/01/2007
14	66	AUDIO: SPEAKER AMP	M88_AUDIO	11/01/2007
15	67	AUDIO: JACKS	M88_AUDIO	11/01/2007
16	68	AUDIO: JACK TRANSLATORS	M88_AUDIO	11/01/2007
17	69	DC-In & PBUS Connectors	(MASTER)	(MASTER)
18	76	5V/3.3V SUPPLY	M57_LIO	11/30/2006
19	77	Cross Reference Page		
20	78	Cross Reference Page		
21	101		M88_AUDIO	11/01/2007
22	102	Cross Reference Page		
23	103	Cross Reference Page		

PART#	QTY	DESCRIPTION	REFERENCE DESIGNATOR(S)	CRITICAL	BOM OPTION
051-7448	1	SCHEM, LEFT IO Board, M88, MBP17	SCH	CRITICAL	
820-2274	1	PCBF, LEFT IO Board, M88, MBP17	PCB	CRITICAL	

DIMENSIONS ARE IN MILLIMETERS		<b>METRIC</b>		<b>APPLE INC.</b>	
XX : _____	_____	DRAPTER	DESIGN CK	NOTICE OF PROPRIETARY PROPERTY THE INFORMATION CONTAINED HEREIN IS THE PROPRIETARY PROPERTY OF APPLE COMPUTER, INC. THE POSSESSOR AGREES TO THE FOLLOWING: I TO MAINTAIN THE DOCUMENT IN CONFIDENCE II NOT TO REPRODUCE OR COPY IT III NOT TO REVEAL OR PUBLISH IN WHOLE OR PART	
X.XX : _____	_____	ENG APPD	MFG APPD		
X.XXX : _____	_____	QA APPD	DESIGNER		
ANGLES : _____	_____	RELEASE	SCALE		
DO NOT SCALE DRAWING		SCALE NONE		TITLE	
 THIRD ANGLE PROJECTION		MATERIAL/FINISH NOTED AS APPLICABLE		SIZE D	DRAWING NUMBER <b>051-7448</b>
				REV. <b>A</b>	SHT 1 OF 78

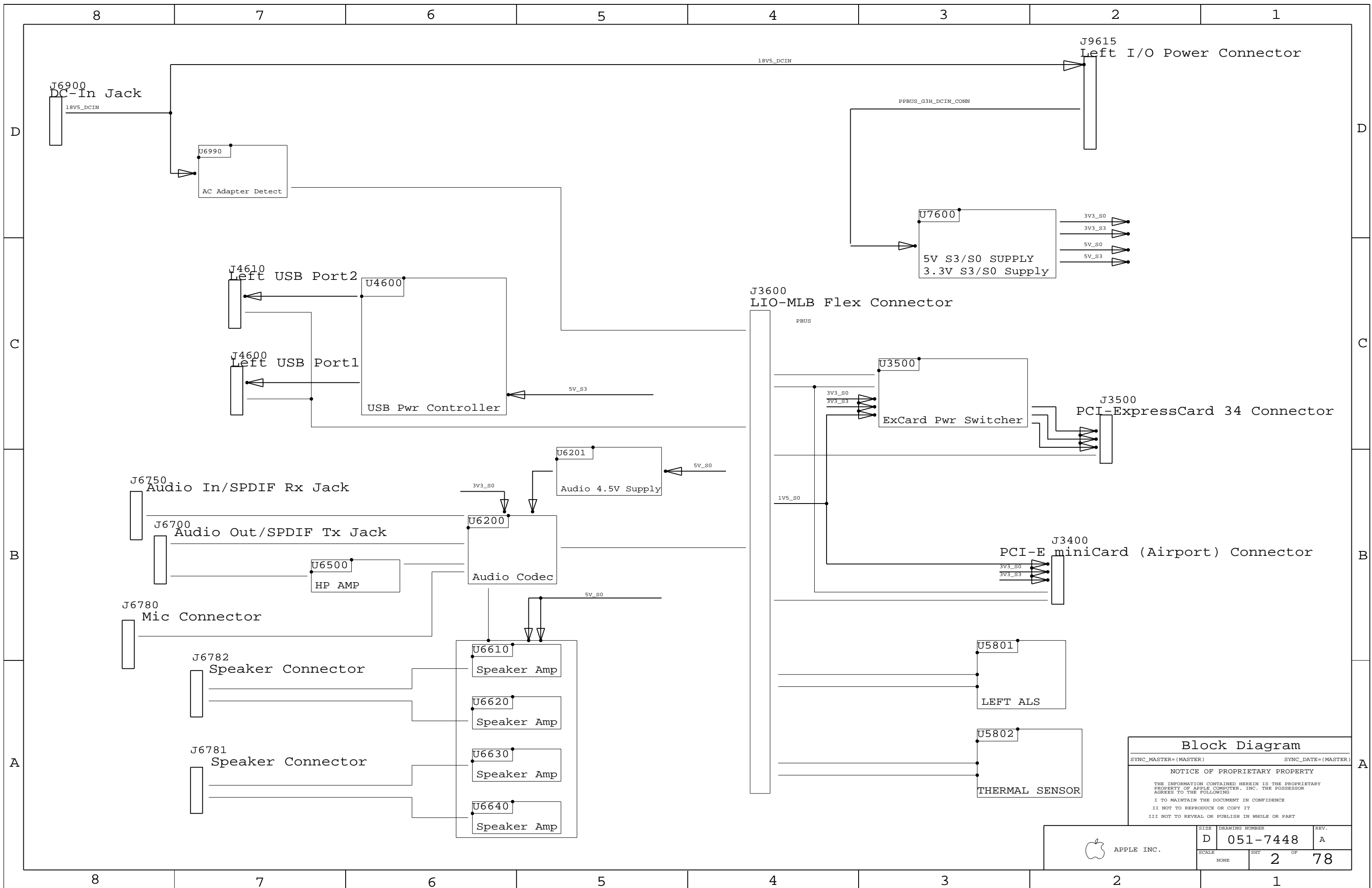

**Block Diagram**

SYNC\_MASTER=(MASTER)      SYNC\_DATE=(MASTER)

NOTICE OF PROPRIETARY PROPERTY

THE INFORMATION CONTAINED HEREIN IS THE PROPRIETARY PROPERTY OF APPLE COMPUTER, INC. THE POSSESSOR AGREES TO THE FOLLOWING

I TO MAINTAIN THE DOCUMENT IN CONFIDENCE

II NOT TO REPRODUCE OR COPY IT

III NOT TO REVEAL OR PUBLISH IN WHOLE OR PART

APPLE INC.	SIZE <b>D</b>	DRAWING NUMBER <b>051-7448</b>	REV. <b>A</b>
	SCALE NONE	SHEET <b>2</b>	OF <b>78</b>

8

7

6

5

4

3

2

1

BOM NUMBER	BOM NAME	BOM OPTIONS
630-9095	PCBA, KILKENNY, M88	COMMON, ALTERNATE, ALS_NTC, COMBOJACK

PART NUMBER	ALTERNATE FOR PART NUMBER	BOM OPTION	REF DES	COMMENTS:
353S1297	353S1717		U6990	TI Alt Src
152S0683	152S0276		L7600, L7650	MAGLAYER Alt Src

BAR CODE LABEL / EEE#'S

PART NUMBER	QTY	DESCRIPTION	REFERENCE DES	CRITICAL	BOM OPTION
000-0041	1	LBL, P/N LABEL, PCB	[EEE:Z3N]	CRITICAL	

PART#	QTY	DESCRIPTION	REFERENCE DESIGNATOR(S)	CRITICAL	BOM OPTION
815-8851	1	ALS SPACER, M9	SP6401	CRITICAL	

D

D

C

C

B

B

A

A

BOM CONFIGURATION	
SYNC_MASTER=(MASTER)	SYNC_DATE=(MASTER)
NOTICE OF PROPRIETARY PROPERTY	
THE INFORMATION CONTAINED HEREIN IS THE PROPRIETARY PROPERTY OF APPLE COMPUTER, INC. THE POSSESSOR AGREES TO THE FOLLOWING	
I TO MAINTAIN THE DOCUMENT IN CONFIDENCE	
II NOT TO REPRODUCE OR COPY IT	
III NOT TO REVEAL OR PUBLISH IN WHOLE OR PART	

 APPLE INC.	SIZE	DRAWING NUMBER	REV.
	D	051-7448	A
SCALE	SHT	OF	
NONE	4	78	

8

7

6

5

4

3

2

1

8

7

6

5

4

3

2

1

### Version History

Proto

07/17/07 -- Left ALS: Changed TMP106 to TMP102 (TALP sensor)  
 07/17/07 -- Left ALS: Added R5808 as NTC thermistor (with ALS\_NTC BOMOPTION)  
 07/17/07 -- DC-In: Moved J9615 to DC-In/PBUS page (deleted page 96)

D

D

C

C

B

B

A

A

Version History	
SYNC_MASTER=(MASTER)	SYNC_DATE=(MASTER)
NOTICE OF PROPRIETARY PROPERTY	
THE INFORMATION CONTAINED HEREIN IS THE PROPRIETARY PROPERTY OF APPLE COMPUTER, INC. THE POSSESSOR AGREES TO THE FOLLOWING	
I TO MAINTAIN THE DOCUMENT IN CONFIDENCE	
II NOT TO REPRODUCE OR COPY IT	
III NOT TO REVEAL OR PUBLISH IN WHOLE OR PART	

 APPLE INC.	SIZE	DRAWING NUMBER	REV.
	D	051-7448	A
SCALE	SHT	OF	
NONE	5	78	

8

7

6

5

4

3

2

1

POWER & GROUNDS



AUDIO POWER & GROUNDS

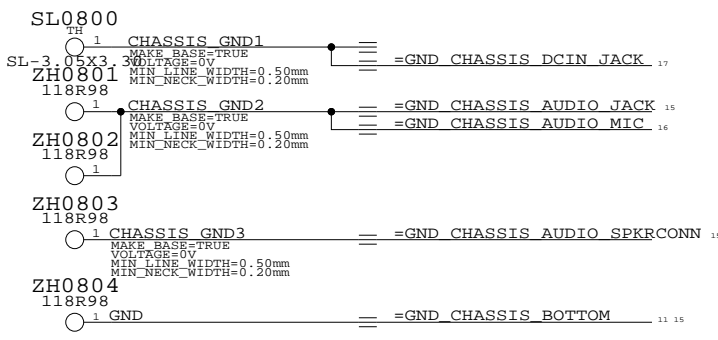
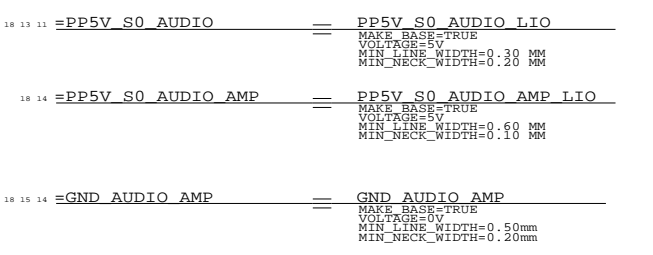

PCI-E EXPRESS CARD 34

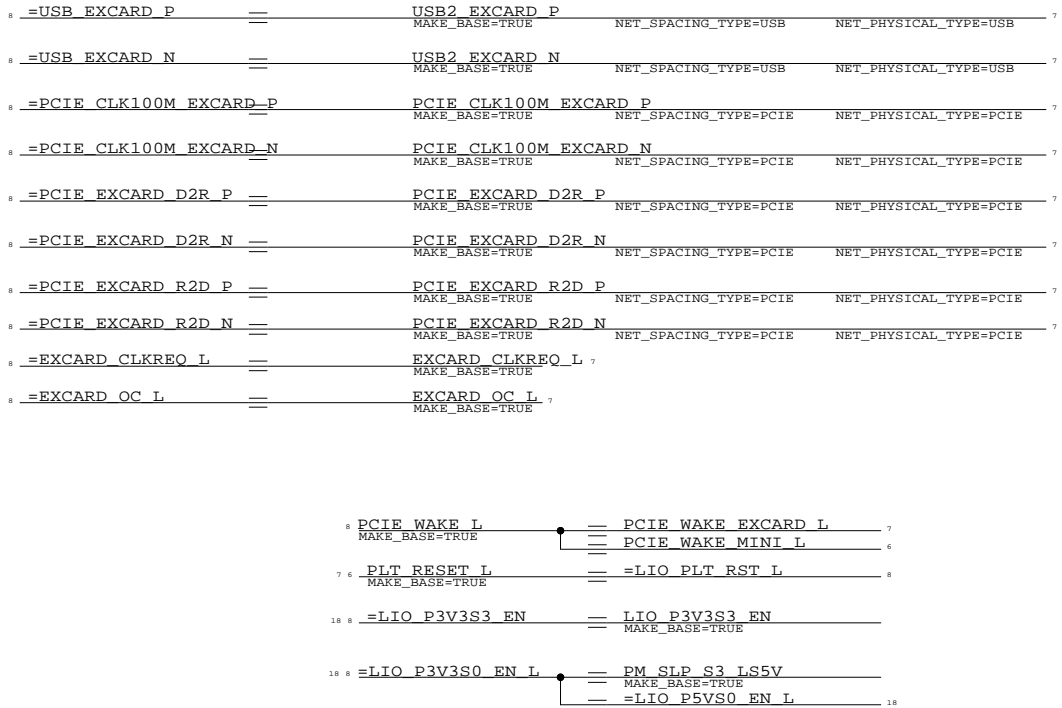

PCI-E MINICARD

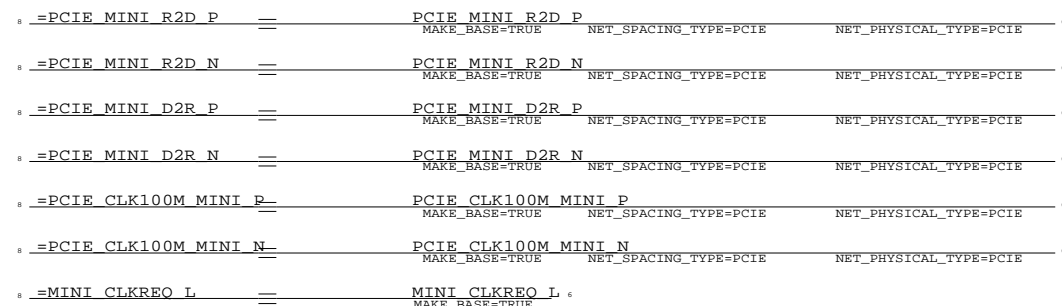

USB

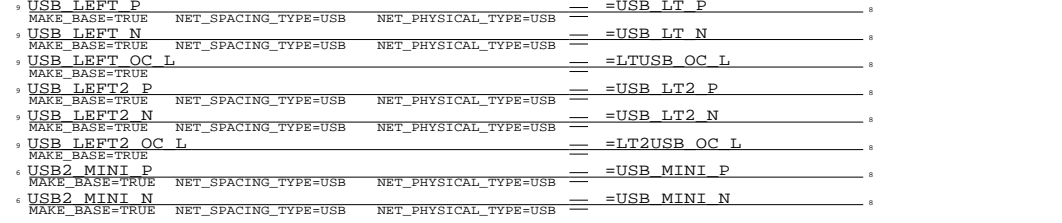

SMBUS

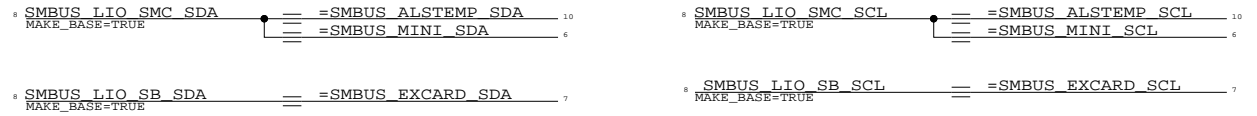

**Aliases**

SYNC\_MASTER=(MASTER) SYNC\_DATE=(MASTER)

**NOTICE OF PROPRIETARY PROPERTY**

THE INFORMATION CONTAINED HEREIN IS THE PROPRIETARY PROPERTY OF APPLE COMPUTER, INC. THE POSSESSOR AGREES TO THE FOLLOWING

I TO MAINTAIN THE DOCUMENT IN CONFIDENCE

II NOT TO REPRODUCE OR COPY IT

III NOT TO REVEAL OR PUBLISH IN WHOLE OR PART

APPLE INC.

SIZE	DRAWING NUMBER	REV.
D	051-7448	A
SCALE	SHT	OF
NONE	8	78

# PCI-EXPRESS MINI CARD CONNECTOR

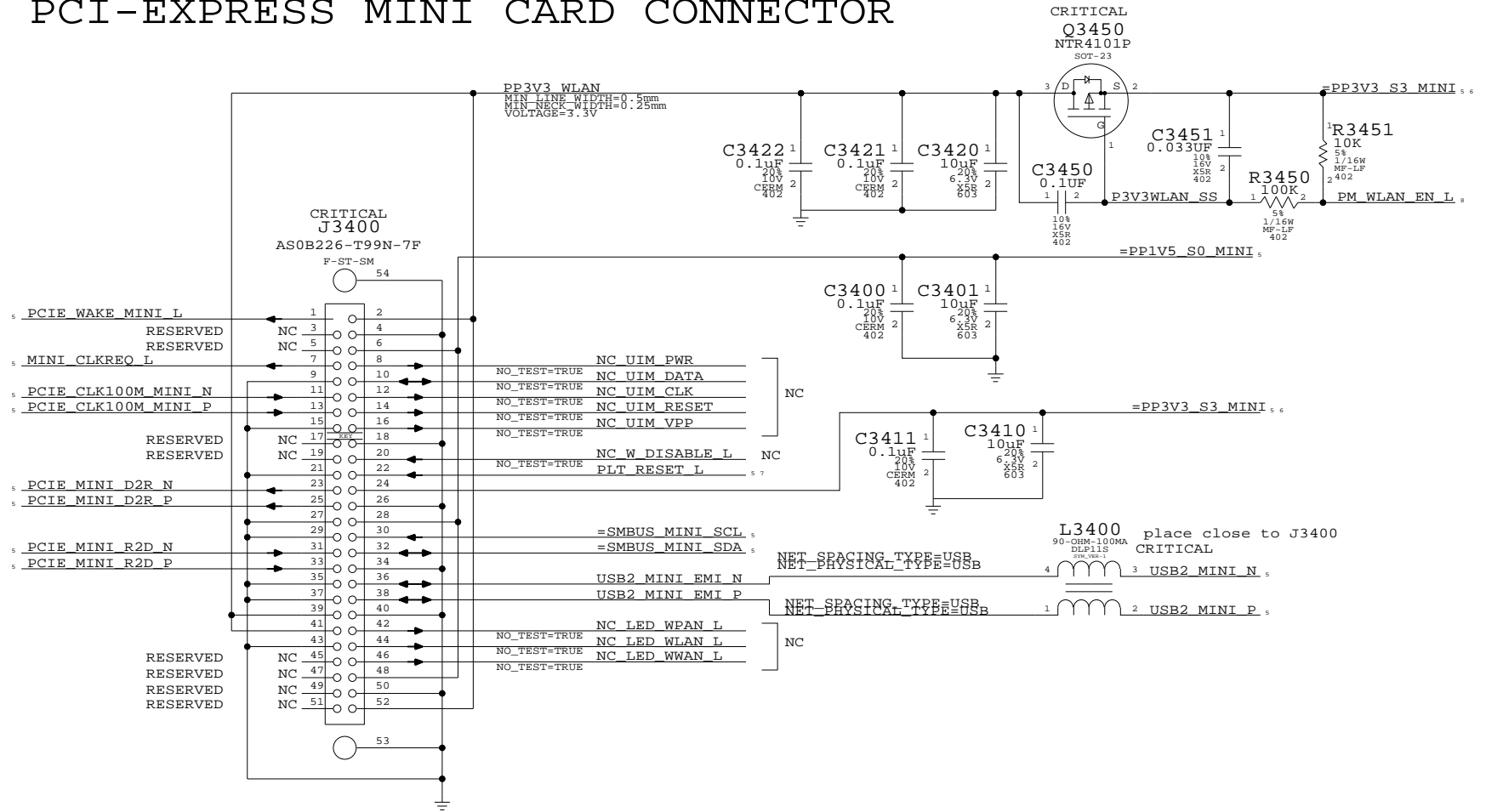

## PCI-E MiniCard Connector

SYNC\_MASTER=M75\_L10 SYNC\_DATE=04/10/2007

### NOTICE OF PROPRIETARY PROPERTY

THE INFORMATION CONTAINED HEREIN IS THE PROPRIETARY PROPERTY OF APPLE COMPUTER, INC. THE POSSESSOR AGREES TO THE FOLLOWING

- I TO MAINTAIN THE DOCUMENT IN CONFIDENCE
- II NOT TO REPRODUCE OR COPY IT
- III NOT TO REVEAL OR PUBLISH IN WHOLE OR PART

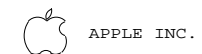

APPLE INC.

SIZE	DRAWING NUMBER	REV.
D	051-7448	A
SCALE	SHT	OF
NONE	34	78

# EXPRESSCARD/34 TOP MOUNT CONNECTOR

CARD CAGE CONNECTOR  
CRITICAL  
J3500  
237-5300703903-2  
P-RF-SM

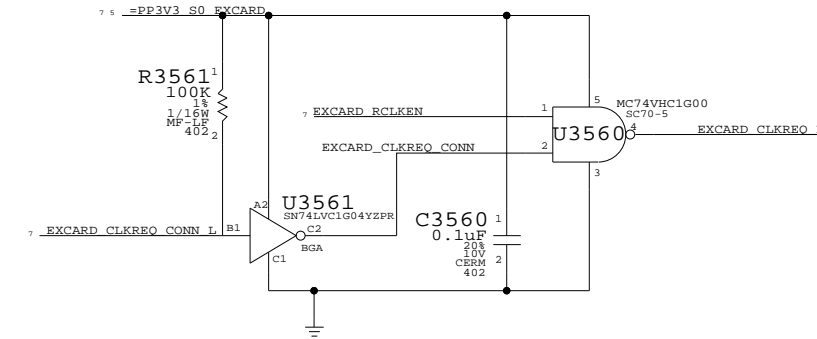
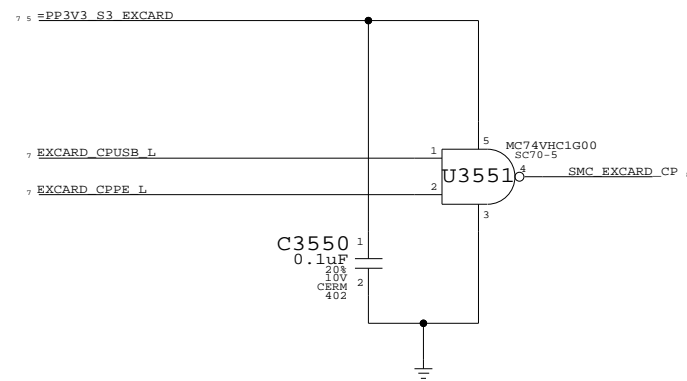
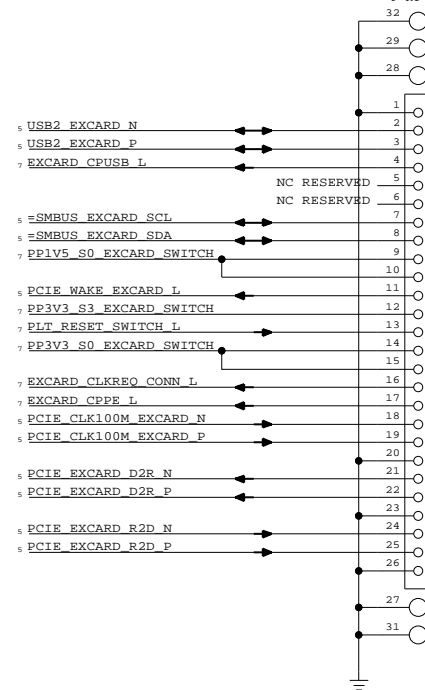
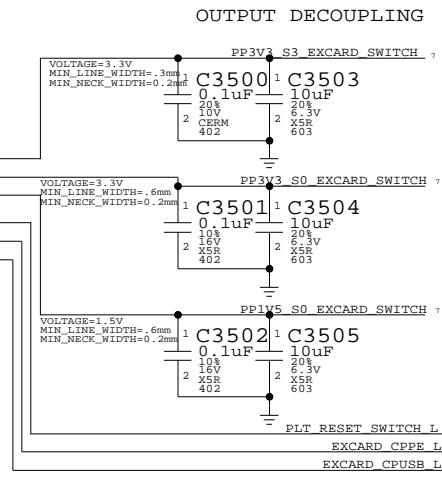
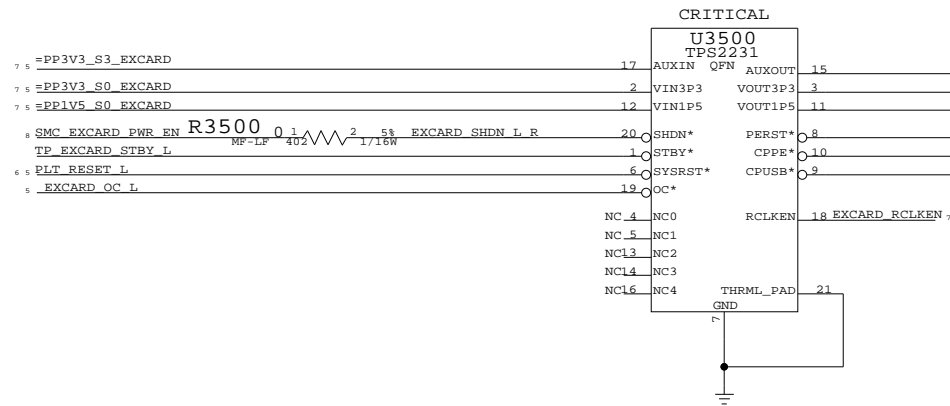
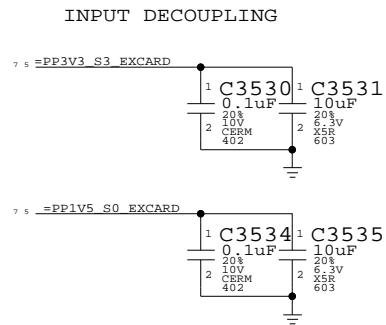

**ExpressCard Connector**  
 SYNC\_MASTER=M75\_LIO SYNC\_DATE=04/10/2007  
**NOTICE OF PROPRIETARY PROPERTY**  
 THE INFORMATION CONTAINED HEREIN IS THE PROPRIETARY PROPERTY OF APPLE COMPUTER, INC. THE POSSESSOR AGREES TO THE FOLLOWING:  
 I TO MAINTAIN THE DOCUMENT IN CONFIDENCE  
 II NOT TO REPRODUCE OR COPY IT  
 III NOT TO REVEAL OR PUBLISH IN WHOLE OR PART

APPLE INC.	SIZE	DRAWING NUMBER	REV.
	D	051-7448	A
SCALE	SHT		OF
NONE	35		78

# Left I/O Board Connector

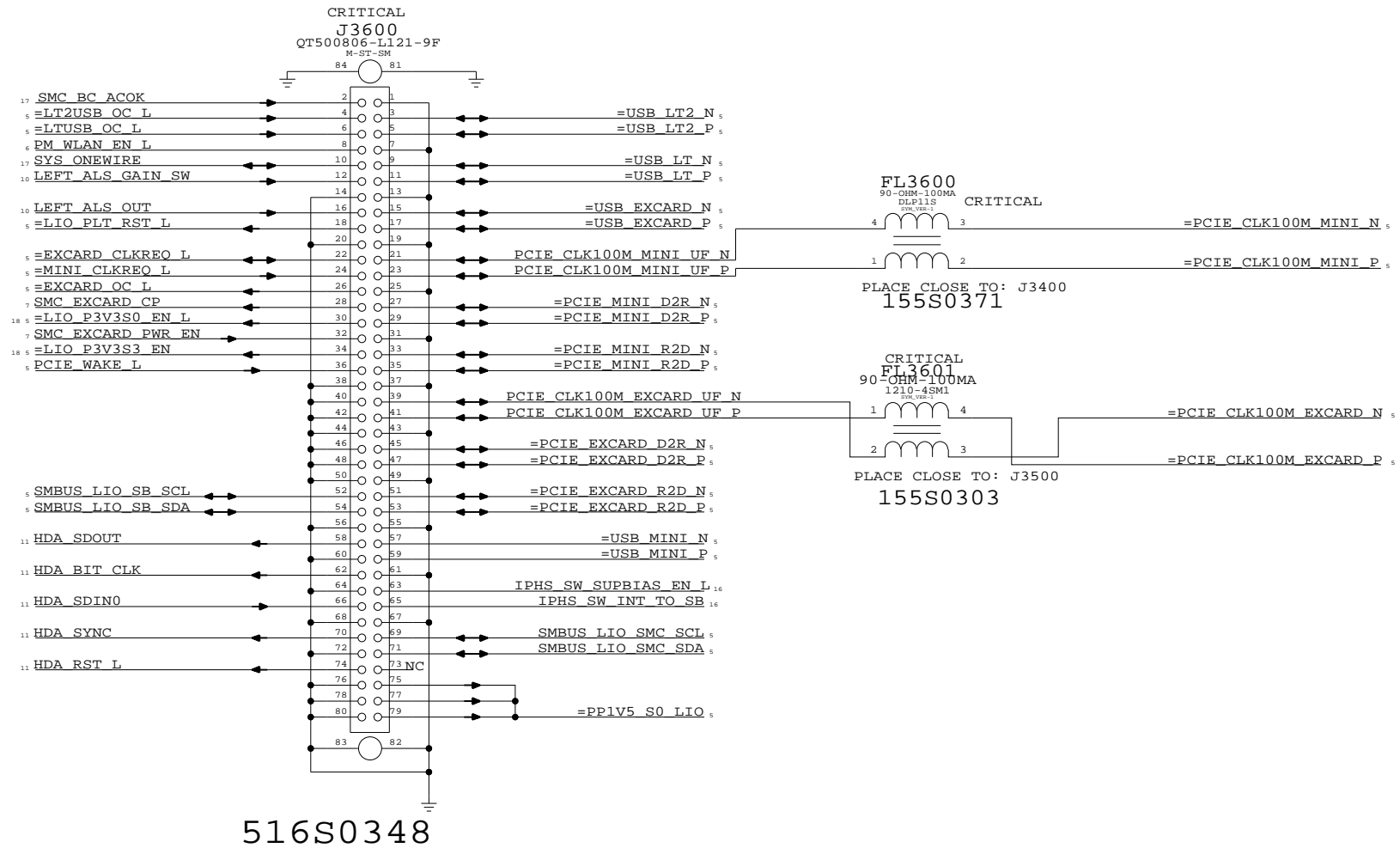

## MLB I/O Board Connector

SYNC\_MASTER=(MASTER) SYNC\_DATE=(MASTER)

### NOTICE OF PROPRIETARY PROPERTY

THE INFORMATION CONTAINED HEREIN IS THE PROPRIETARY PROPERTY OF APPLE COMPUTER, INC. THE POSSESSOR AGREES TO THE FOLLOWING  
 I TO MAINTAIN THE DOCUMENT IN CONFIDENCE  
 II NOT TO REPRODUCE OR COPY IT  
 III NOT TO REVEAL OR PUBLISH IN WHOLE OR PART

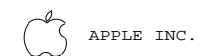

SIZE	DRAWING NUMBER	REV.
D	051-7448	A
SCALE	SHT 36 OF 78	
NONE		



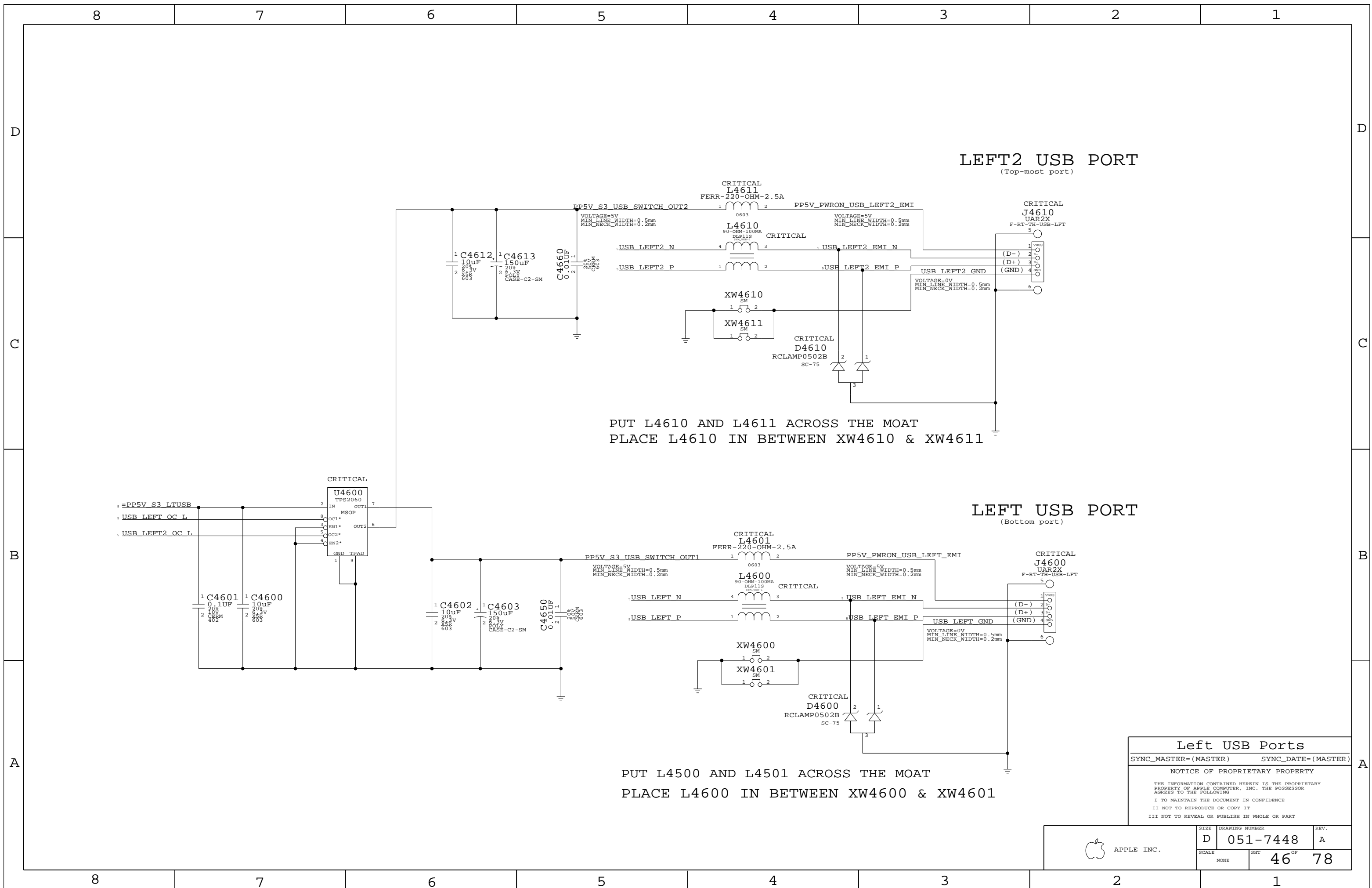

**Left USB Ports**

SYNC\_MASTER=(MASTER)      SYNC\_DATE=(MASTER)

NOTICE OF PROPRIETARY PROPERTY

THE INFORMATION CONTAINED HEREIN IS THE PROPRIETARY PROPERTY OF APPLE COMPUTER, INC. THE POSSESSOR AGREES TO THE FOLLOWING

I TO MAINTAIN THE DOCUMENT IN CONFIDENCE

II NOT TO REPRODUCE OR COPY IT

III NOT TO REVEAL OR PUBLISH IN WHOLE OR PART

 APPLE INC.	SIZE	DRAWING NUMBER	REV.
	D	051-7448	A
SCALE	SHT 46 OF 78		
NONE			

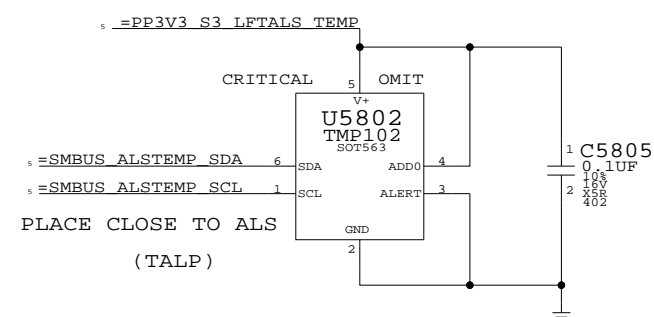
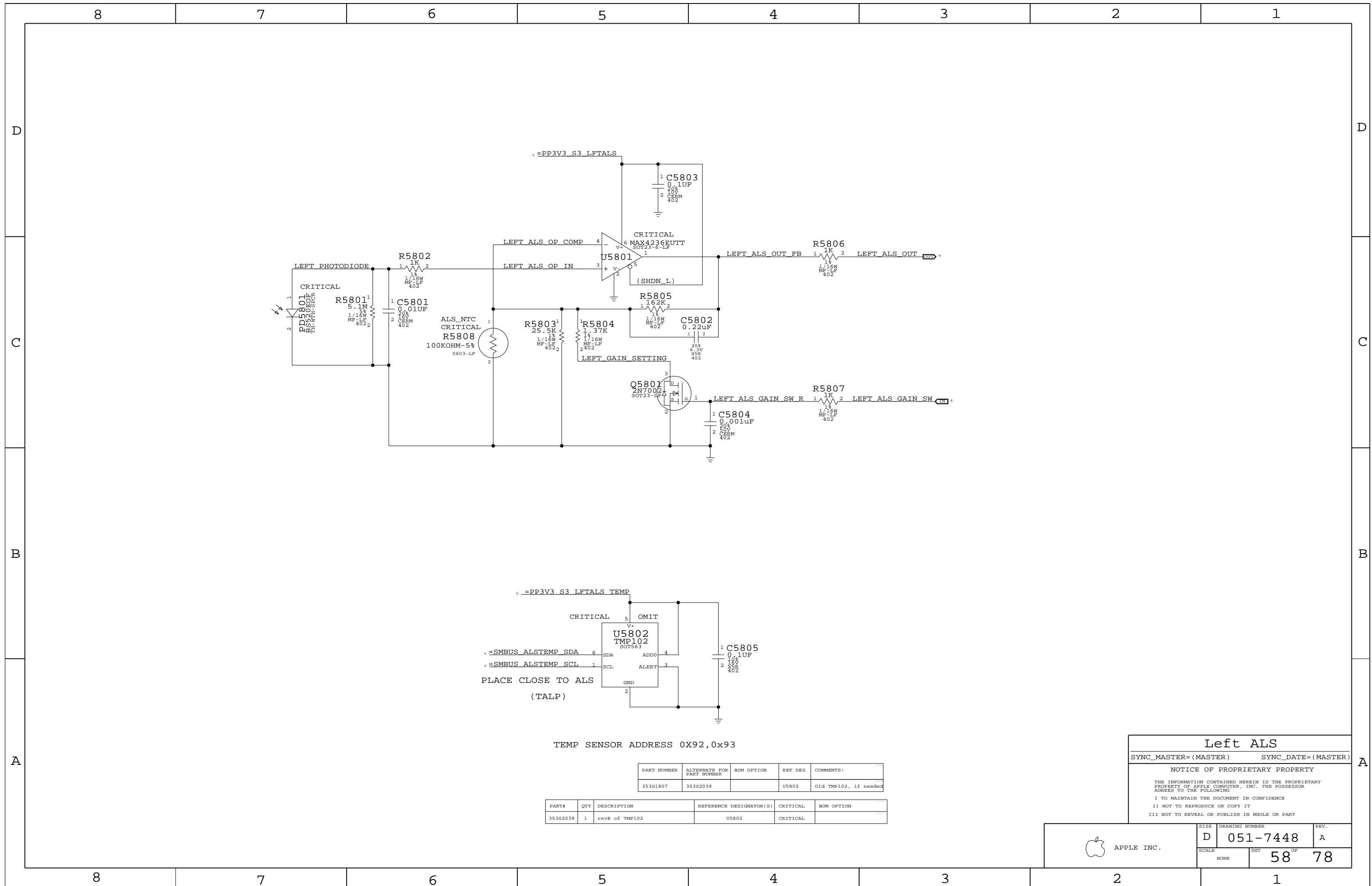

TEMP SENSOR ADDRESS 0x92,0x93

PART NUMBER	ALTERNATE FOR PART NUMBER	BOM OPTION	REF DES	COMMENTS:
353S1807	353S2039		U5802	Old TMP102, if needed

PART#	QTY	DESCRIPTION	REFERENCE DESIGNATOR(S)	CRITICAL	BOM OPTION
353S2039	1	revE of TMP102	U5802	CRITICAL	

**Left ALS**

SYNC\_MASTER=(MASTER)      SYNC\_DATE=(MASTER)

**NOTICE OF PROPRIETARY PROPERTY**

THE INFORMATION CONTAINED HEREIN IS THE PROPRIETARY PROPERTY OF APPLE COMPUTER, INC. THE POSSESSOR AGREES TO THE FOLLOWING

I TO MAINTAIN THE DOCUMENT IN CONFIDENCE  
 II NOT TO REPRODUCE OR COPY IT  
 III NOT TO REVEAL OR PUBLISH IN WHOLE OR PART

APPLE INC.	SIZE	DRAWING NUMBER	REV.
	D	051-7448	A
SCALE	SHT		OF
NONE	58		78

AUDIO CODEC  
APPLE P/N 353S1527

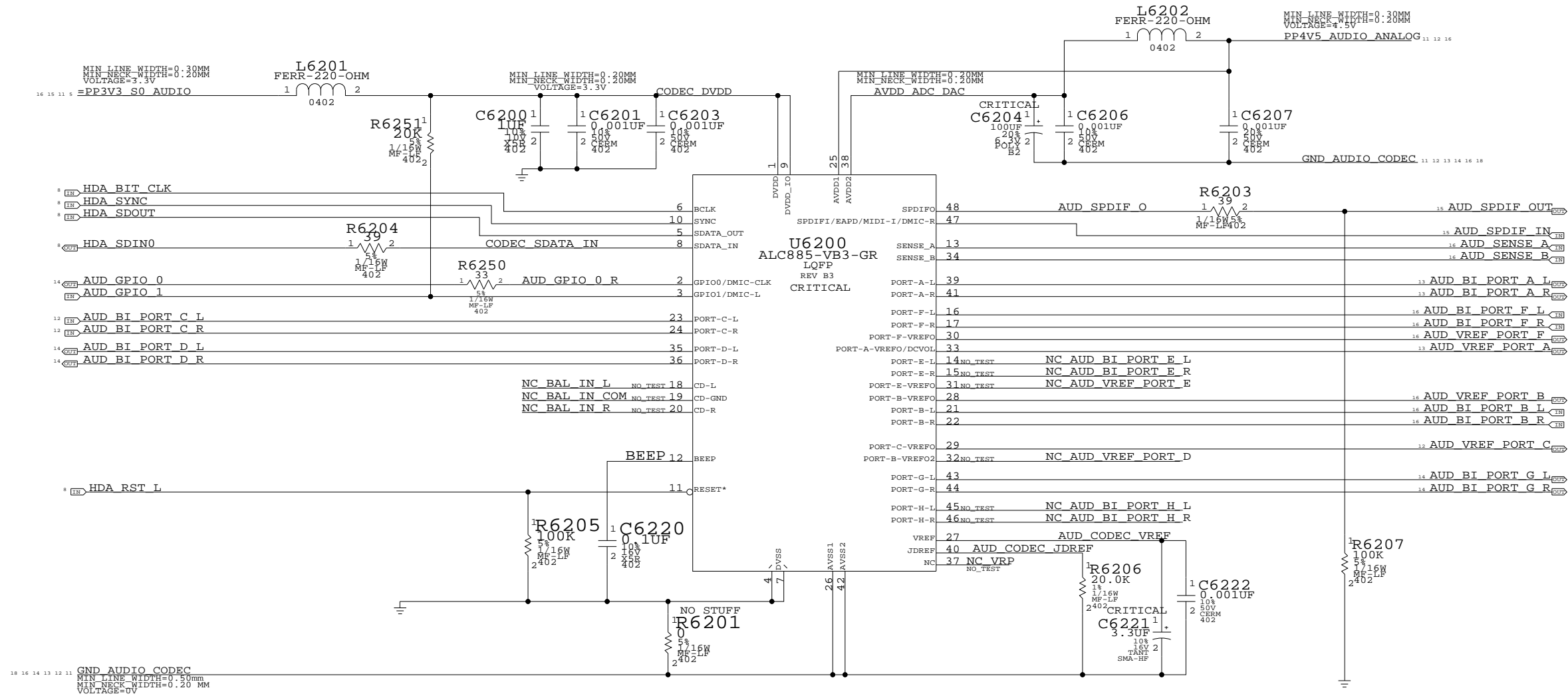

AUDIO 4.5V REGULATOR  
APPLE P/N 353S1576

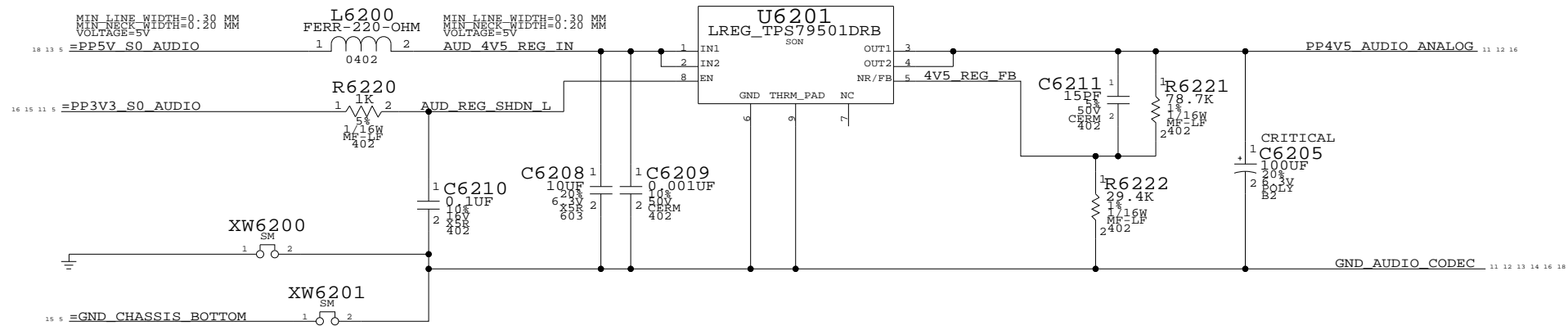

**AUDIO:CODEC**  
 SYNC\_MASTER=M88\_AUDIO SYNC\_DATE=11/01/2007  
 NOTICE OF PROPRIETARY PROPERTY  
 THE INFORMATION CONTAINED HEREIN IS THE PROPRIETARY PROPERTY OF APPLE COMPUTER, INC. THE POSSESSOR AGREES TO THE FOLLOWING:  
 I TO MAINTAIN THE DOCUMENT IN CONFIDENCE  
 II NOT TO REPRODUCE OR COPY IT  
 III NOT TO REVEAL OR PUBLISH IN WHOLE OR PART

APPLE INC.	SIZE	DRAWING NUMBER	REV.
	D	051-7448	A
SCALE	SHT		OF
NONE	62		78

Pseudo-Diff Line-In Filter  
 GAIN = -5.4DB AV = 0.52  
 FC = 6.24 HZ

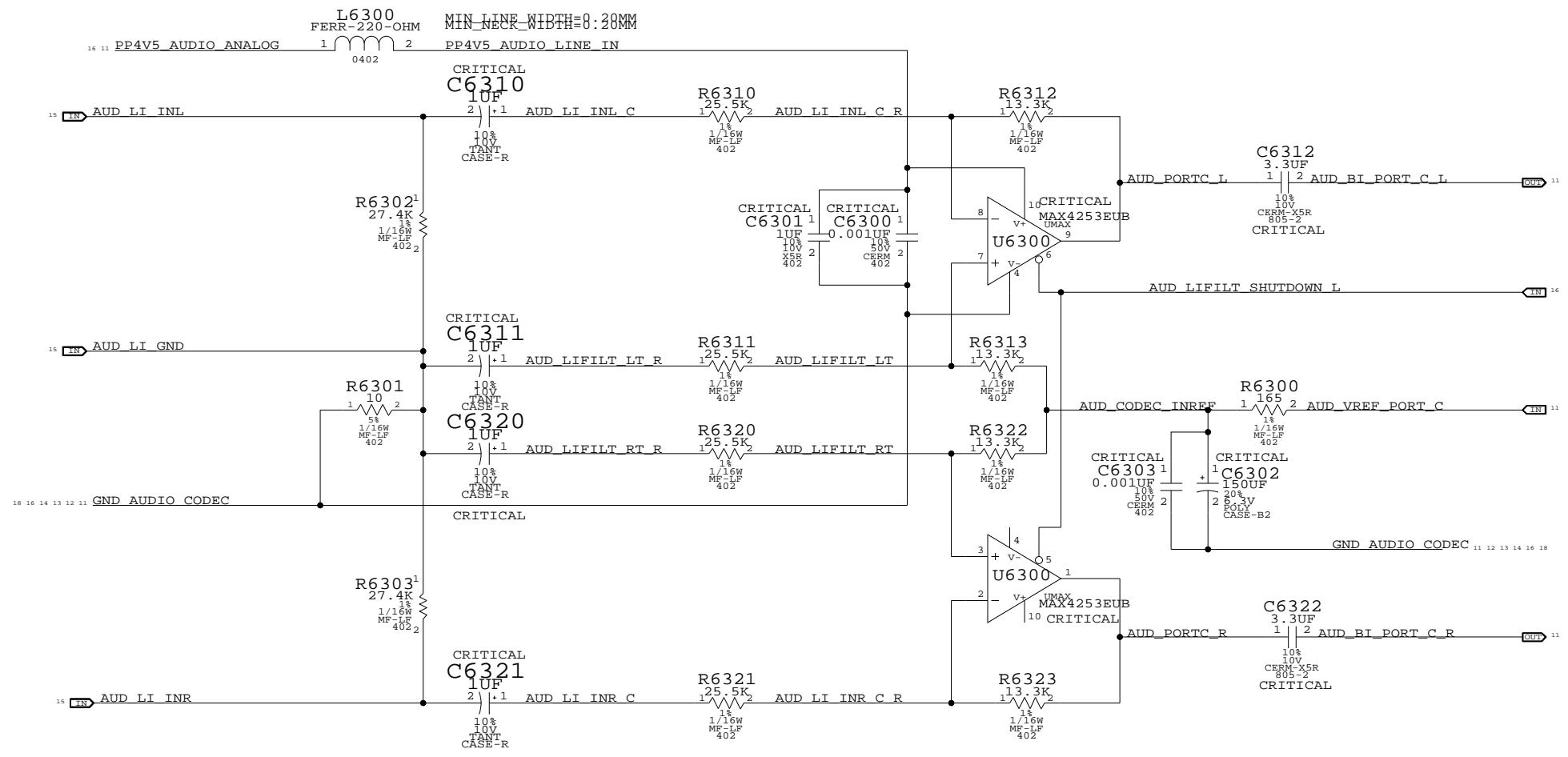

**AUDIO: LINE IN**  
 SYNC\_MASTER=M88\_AUDIO SYNC\_DATE=11/01/2007

NOTICE OF PROPRIETARY PROPERTY  
 THE INFORMATION CONTAINED HEREIN IS THE PROPRIETARY PROPERTY OF APPLE COMPUTER, INC. THE POSSESSOR AGREES TO THE FOLLOWING  
 I TO MAINTAIN THE DOCUMENT IN CONFIDENCE  
 II NOT TO REPRODUCE OR COPY IT  
 III NOT TO REVEAL OR PUBLISH IN WHOLE OR PART

APPLE INC.	SIZE	DRAWING NUMBER	REV.
	D	051-7448	A
SCALE	SHT		OF
NONE	63		78

# Headphone Amplifier (MAX9724A)

APN: 353S1637  
VOLTAGE GAIN: 1.53

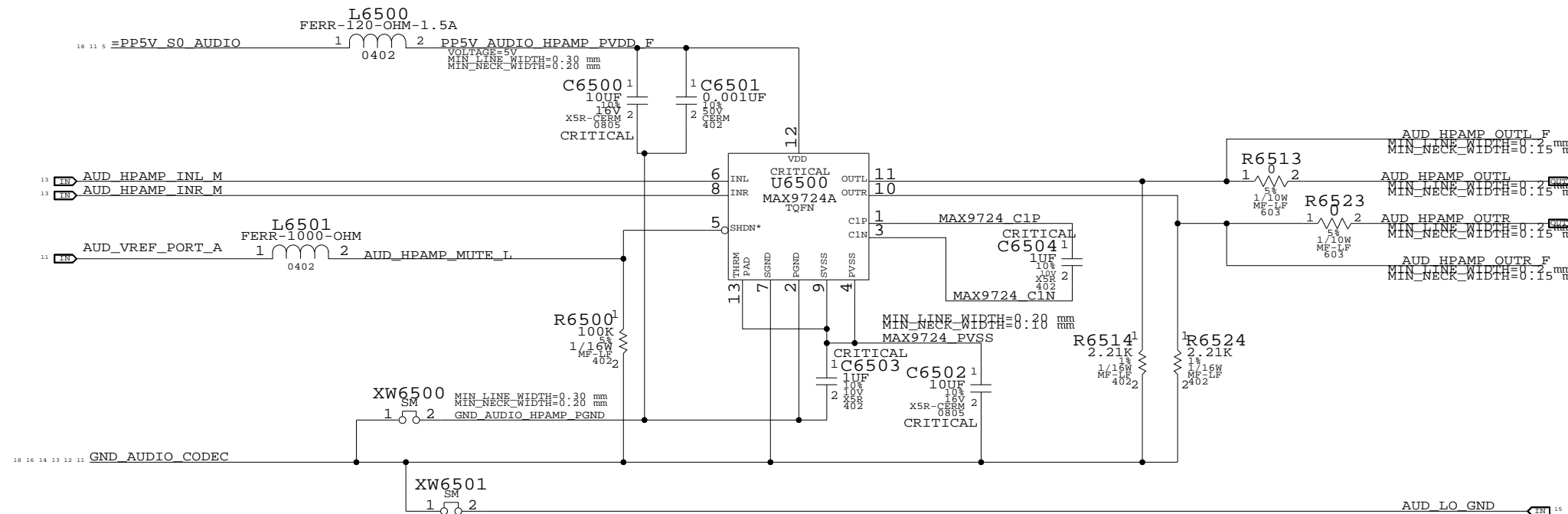

## 2nd Order DAC Filter

HP: 3.52 HZ    LP: 39 KHZ

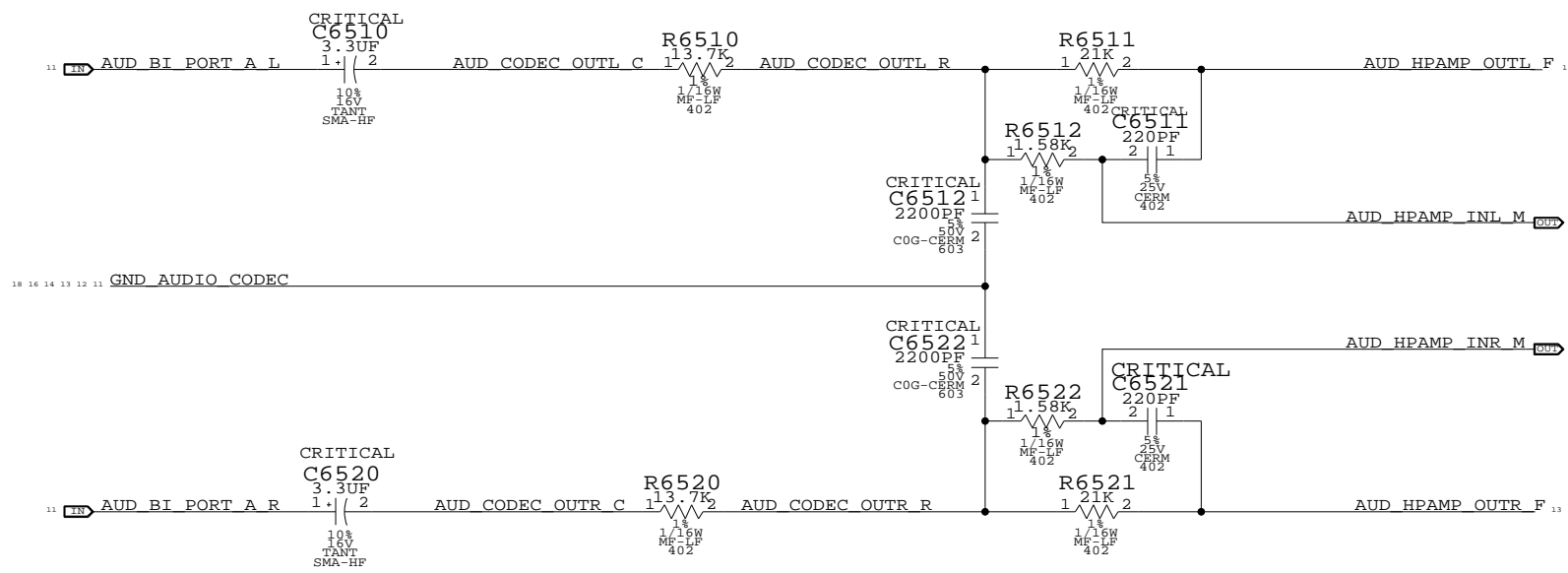

### AUDIO: HEADPHONE AMP

SYNC\_MASTER=M88\_AUDIO    SYNC\_DATE=11/01/2007

#### NOTICE OF PROPRIETARY PROPERTY

THE INFORMATION CONTAINED HEREIN IS THE PROPRIETARY PROPERTY OF APPLE COMPUTER, INC. THE POSSESSOR AGREES TO THE FOLLOWING:  
I TO MAINTAIN THE DOCUMENT IN CONFIDENCE  
II NOT TO REPRODUCE OR COPY IT  
III NOT TO REVEAL OR PUBLISH IN WHOLE OR PART

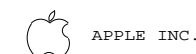

APPLE INC.

SIZE	DRAWING NUMBER	REV.
D	051-7448	A
SCALE	SHT	OF
NONE	65	78

2X MONO SPEAKER AMPLIFIERS (MAX9705B)  
 APN: 353S1595

GAIN = 12DB 79HZ < FC < 132HZ  
 TURN ON TIME: 30MS, TURN ON DELAY: 60MS

VOLTAGE=5V  
 MIN\_LINE\_WIDTH=0.60 MM  
 MIN\_NECK\_WIDTH=0.10 MM

PLACE C6611/C6612 CLOSE TO PVDD PIN

FANCY SPEAKER TESTPOINTS

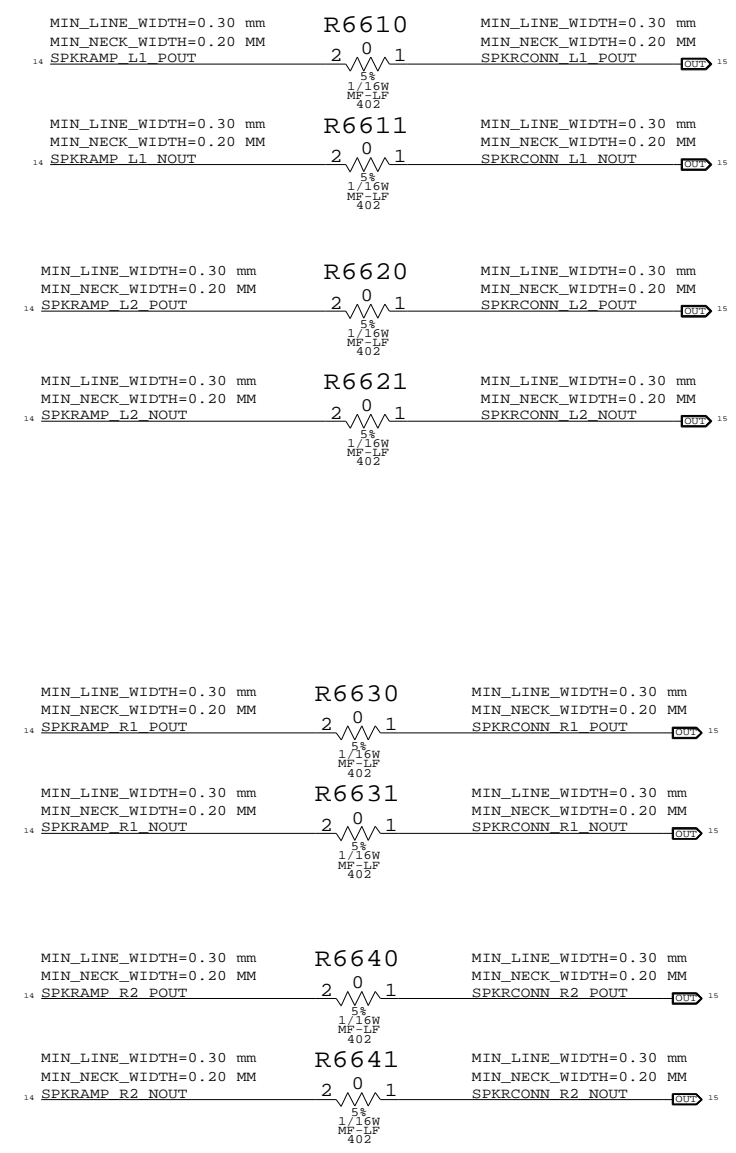
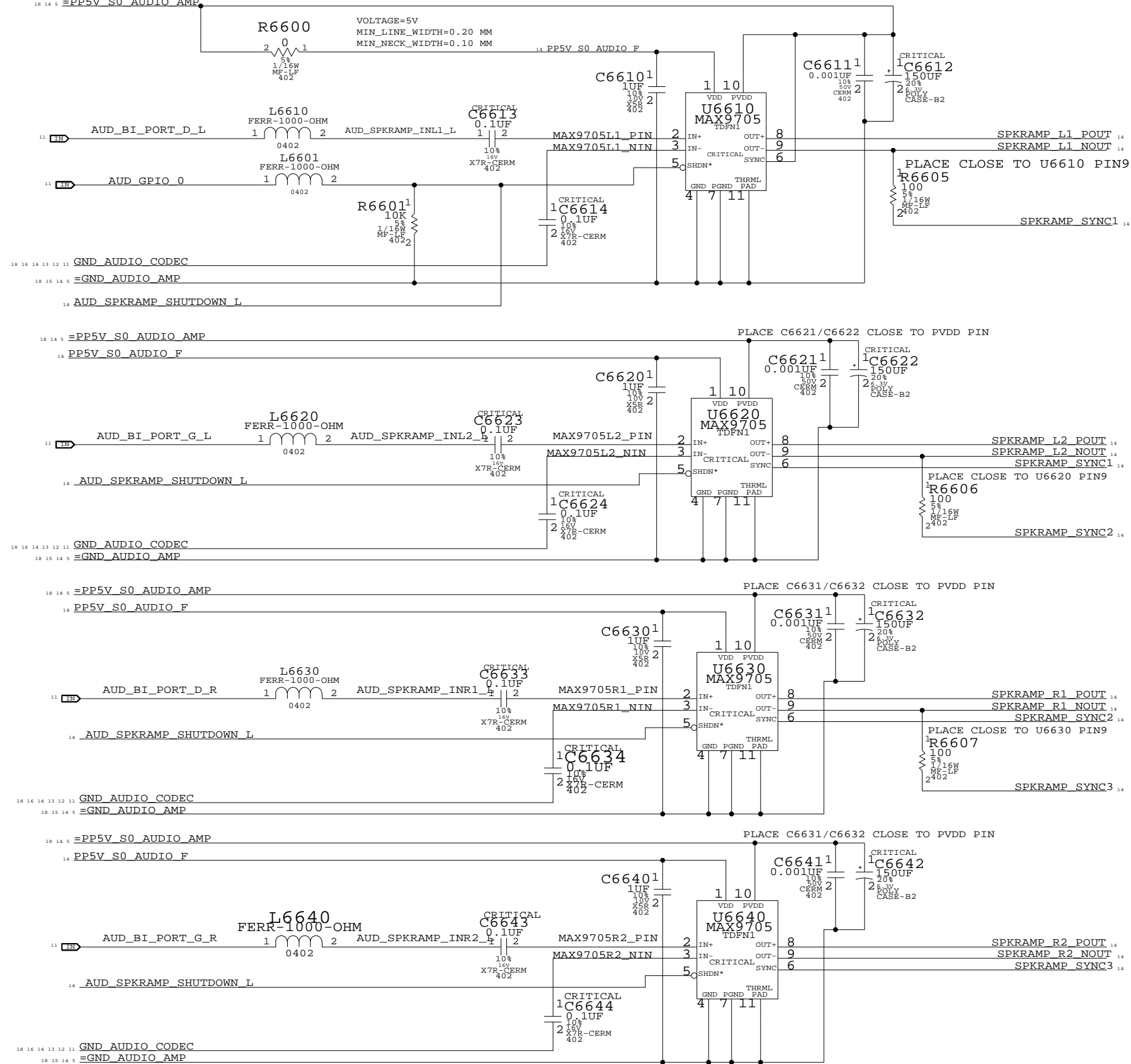

**AUDIO: SPEAKER AMP**  
 SYNC\_MASTER=M88\_AUDIO SYNC\_DATE=11/01/2007  
 NOTICE OF PROPRIETARY PROPERTY  
 THE INFORMATION CONTAINED HEREIN IS THE PROPRIETARY PROPERTY OF APPLE COMPUTER, INC. THE POSSESSOR AGREES TO THE FOLLOWING  
 I TO MAINTAIN THE DOCUMENT IN CONFIDENCE  
 II NOT TO REPRODUCE OR COPY IT  
 III NOT TO REVEAL OR PUBLISH IN WHOLE OR PART

APPLE INC.	SIZE	DRAWING NUMBER	REV.
	D	051-7448	A
SCALE	SHT	66	OF 78
NONE			

PART#	QTY	DESCRIPTION	REFERENCE DESIGNATOR(S)	CRITICAL	BOM OPTION
514-0406	1	CONN, RCPT, OPTICAL-COPPER	J6700	CRITICAL	COMBOJACK

### AUDIO JACK 1 LO/HP CONNECTOR, SPDIF TX

### BUILT-IN MIC CONNECTOR APN: 518-0230

APN: 514-0493

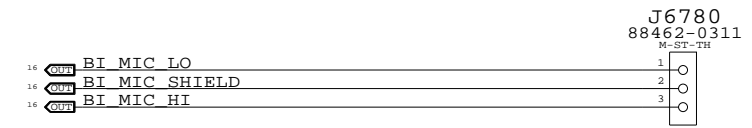
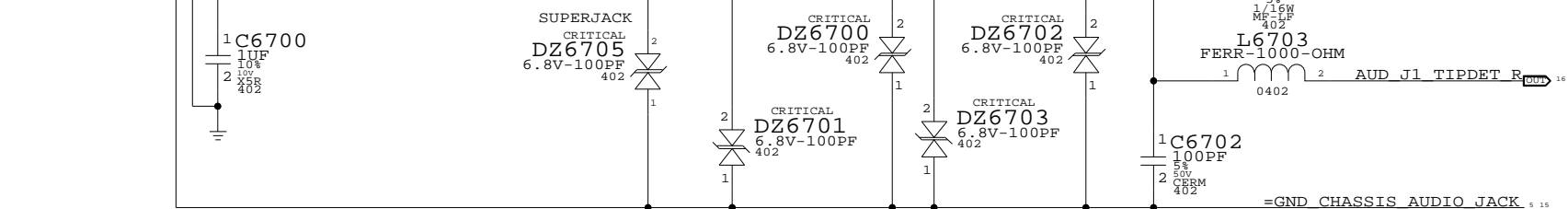
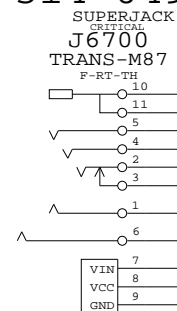

### SPEAKER CONNECTORS APN: 518-0229

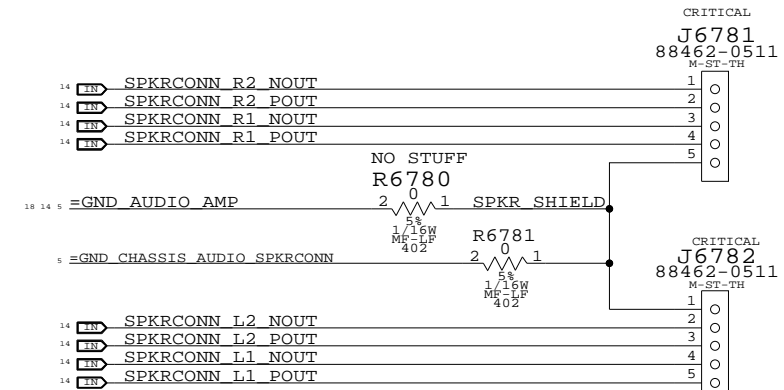

### AUDIO JACK 2 LINE IN CONNECTOR, SPDIF RX

### AUDIO SHIELD ( FILLED SHAPE )

APN: 514-0407

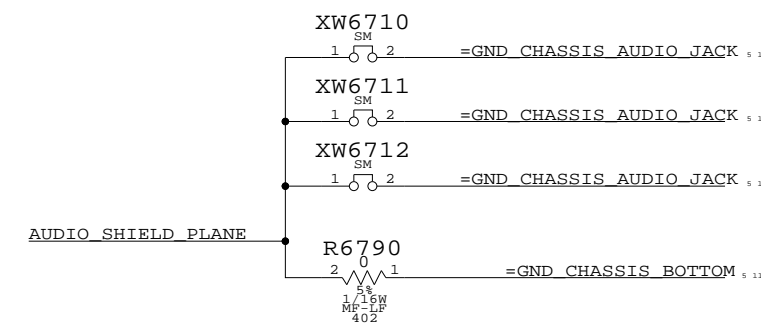
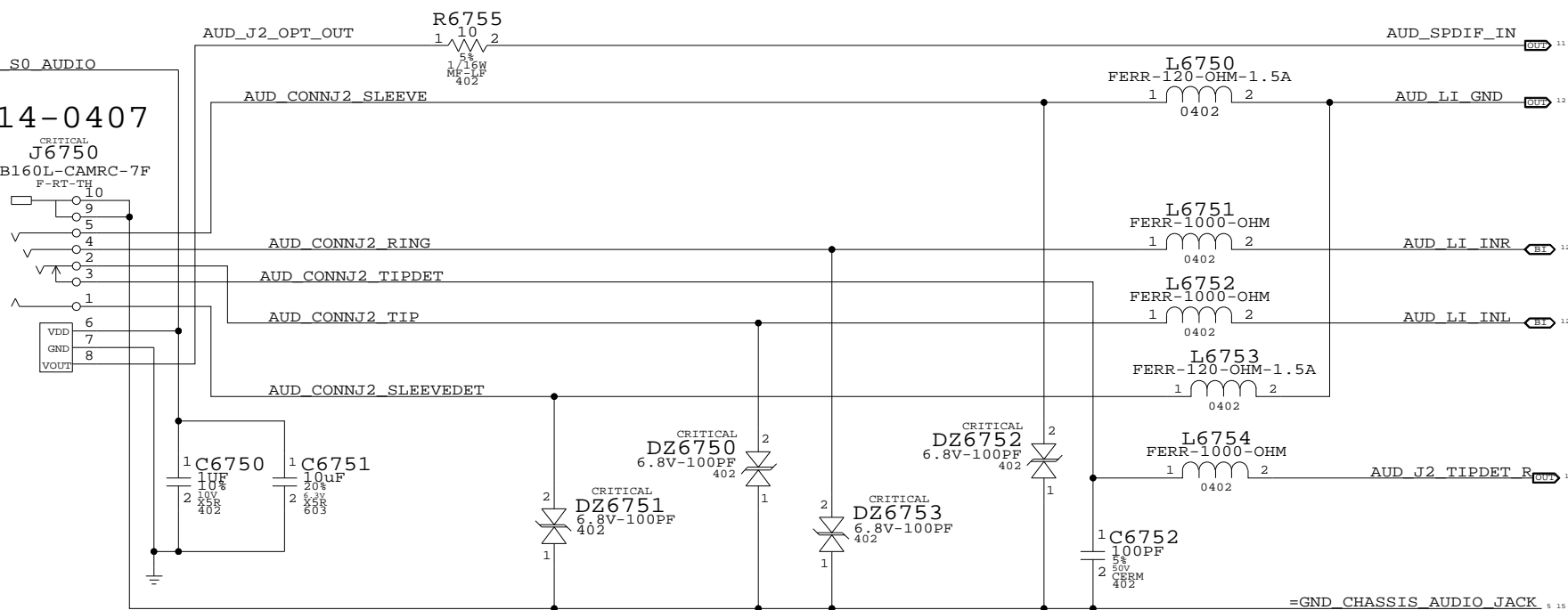
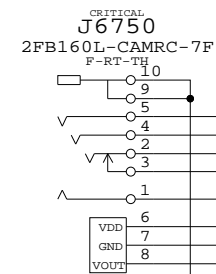

**AUDIO: JACKS**  
 SYNC\_MASTER=M88\_AUDIO SYNC\_DATE=11/01/2007  
 NOTICE OF PROPRIETARY PROPERTY  
 THE INFORMATION CONTAINED HEREIN IS THE PROPRIETARY PROPERTY OF APPLE COMPUTER, INC. THE POSSESSOR AGREES TO THE FOLLOWING  
 I TO MAINTAIN THE DOCUMENT IN CONFIDENCE  
 II NOT TO REPRODUCE OR COPY IT  
 III NOT TO REVEAL OR PUBLISH IN WHOLE OR PART

APPLE INC.	SIZE	DRAWING NUMBER	REV.
	D	051-7448	A
SCALE	NONE	SHT	67 OF 78

CODEC OUTPUT SIGNAL PATHS

FUNCTION	VOLUME	CONVERTER	PIN COMPLEX	MUTE CONTROL	DET ASSIGNMENT
HP/LINE OUT	0X0F (15)	0X05 (05)	0X15 (21,A)	VREF A (21)	0X15 (21,A)
SPEAKER 1	0X26 (38)	0X25 (37)	0X14 (20,D)	GPIO_0	N/A
SPEAKER 2	0X04 (14)	0X04 (04)	0X16 (22,G)	GPIO_0	N/A
SPDIF OUT	N/A	0X06 (06)	0X1E (30,SPDIFTX)	N/A	0X1B (27,E)

CODEC INPUT SIGNAL PATHS

FUNCTION	MIXER (INPUT)	CONVERTER	PIN COMPLEX	VREF	DET ASSIGNMENT
LINE IN	0X23 (35)	0X08 (08)	0X1A (26,C)	N/A	0X1A (26,C)
SPDIF IN	N/A	0X0A (10)	0X1F (31,SPDIFRX)	N/A	N/A
MIC (BUILT IN)	0X24 (36)	0X07 (07)	0X18 (24,B)	B (80%)	N/A
MIC (HEADSET)	0X24 (36)	0X07 (07)	0X19 (25,F)	F (80%)	SouthBridge

PORT B (BUILT-IN MIC)

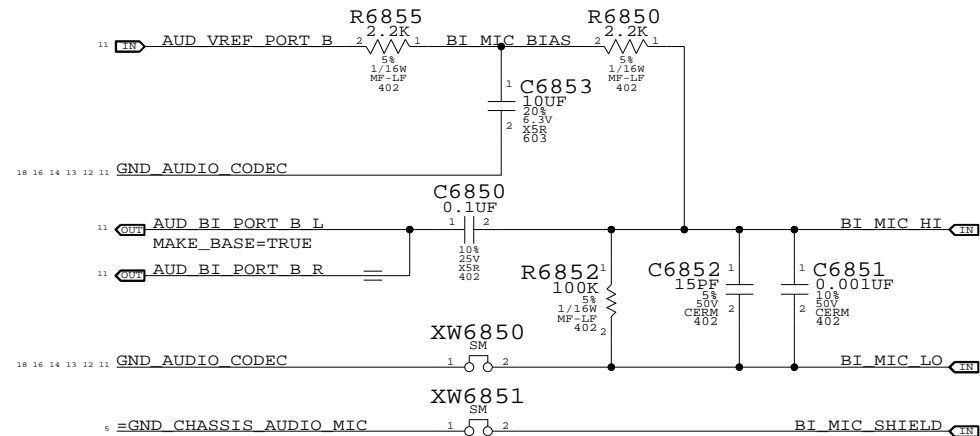

PORT A DETECT (SPDIF) PORT E DETECT (DELEGATE)

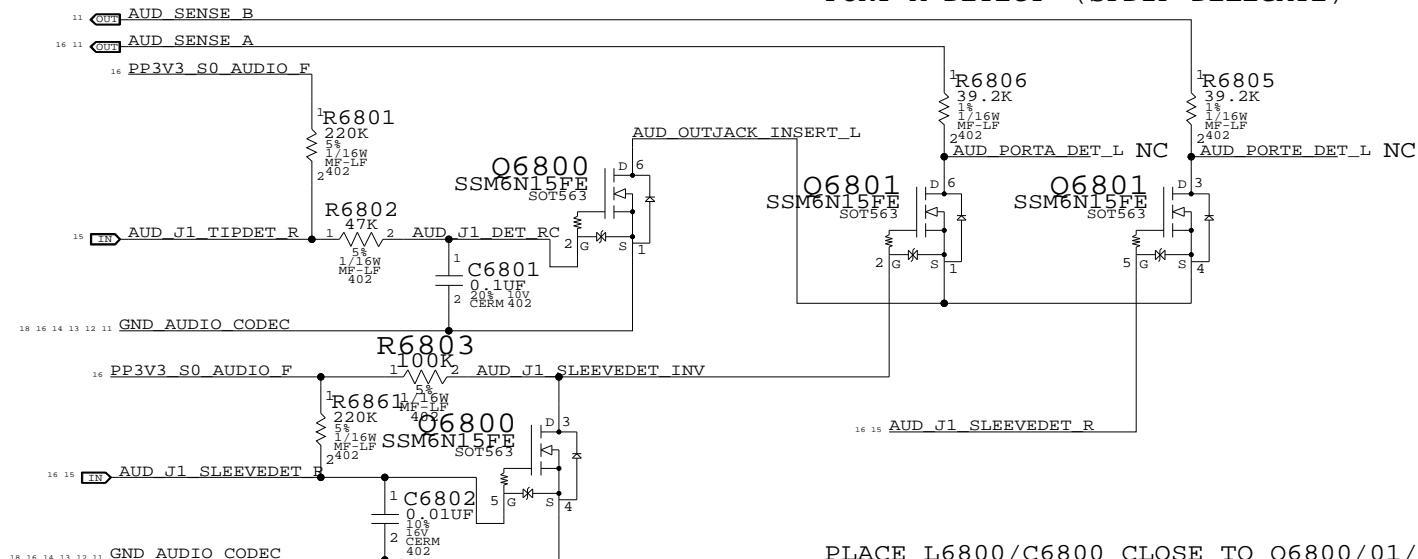

PLACE L6800/C6800 CLOSE TO Q6800/01/02/03

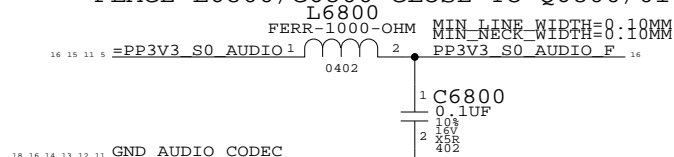

PORT F (HEADSET MIC)

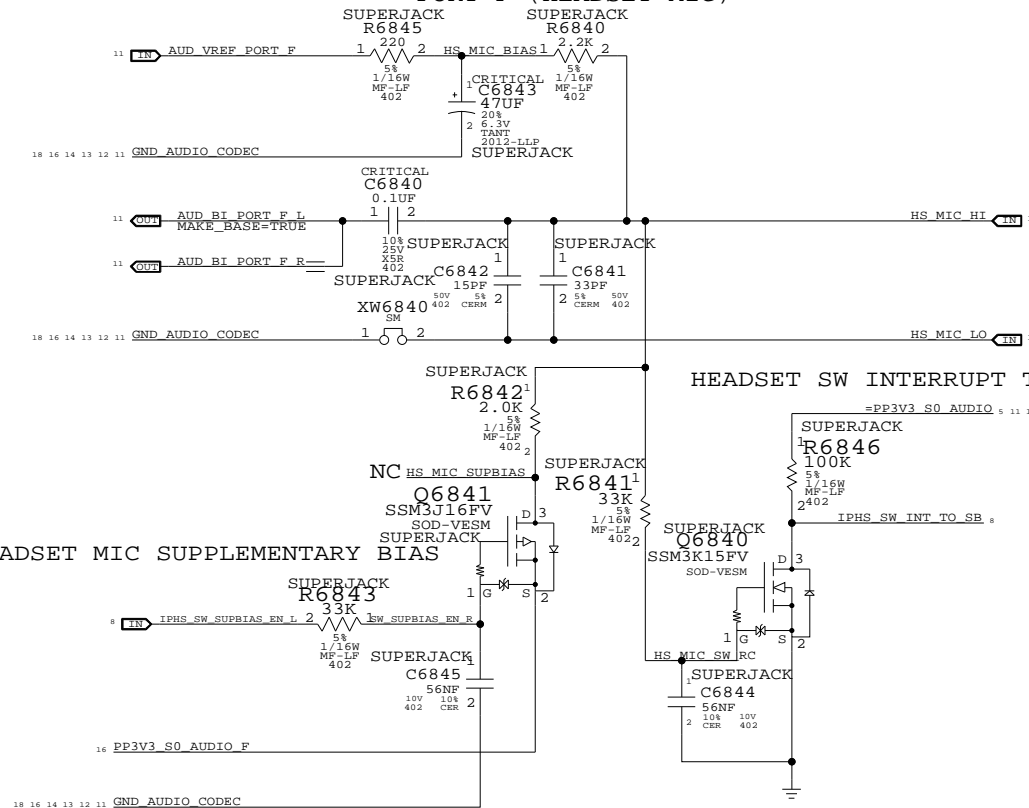

LINE\_IN AMP SHUTDOWN CONTROL

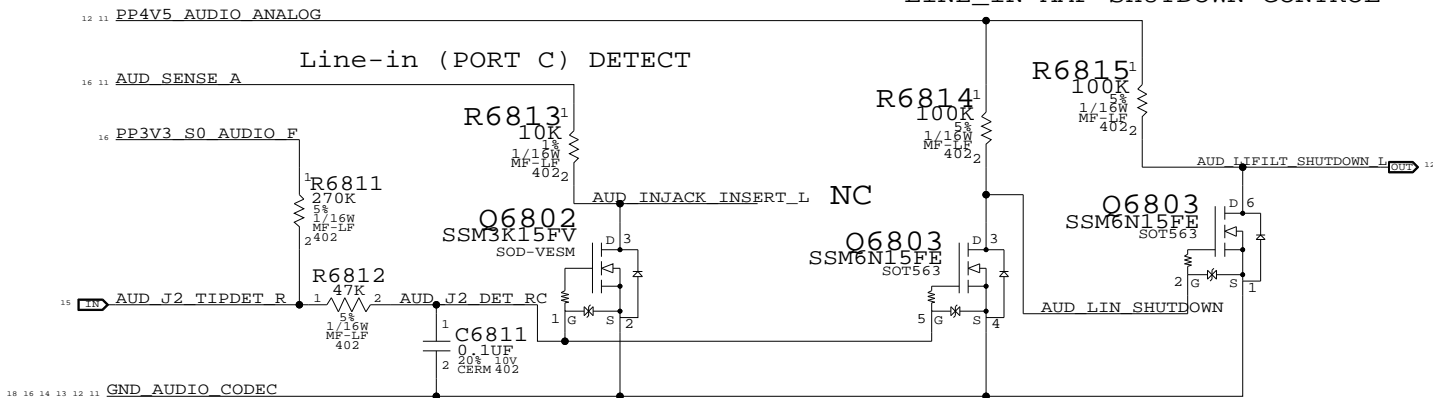

PART#	QTY	DESCRIPTION	REFERENCE DESIGNATOR(S)	CRITICAL	BOM OPTION
138S0578	1	1UF,10%,10V,XSR	C6842	CRITICAL	COMBOJACK
138S0578	1	1UF,10%,10V,XSR	C6840	CRITICAL	COMBOJACK

AUDIO: JACK TRANSLATORS

SYNC\_MASTER=M88\_AUDIO SYNC\_DATE=11/01/2007

NOTICE OF PROPRIETARY PROPERTY

THE INFORMATION CONTAINED HEREIN IS THE PROPRIETARY PROPERTY OF APPLE COMPUTER, INC. THE POSSESSOR AGREES TO THE FOLLOWING  
 I TO MAINTAIN THE DOCUMENT IN CONFIDENCE  
 II NOT TO REPRODUCE OR COPY IT  
 III NOT TO REVEAL OR PUBLISH IN WHOLE OR PART

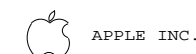

APPLE INC.

SIZE	DRAWING NUMBER	REV.
D	051-7448	A
SCALE	SHT	OF
NONE	68	78



# DC Power Jack

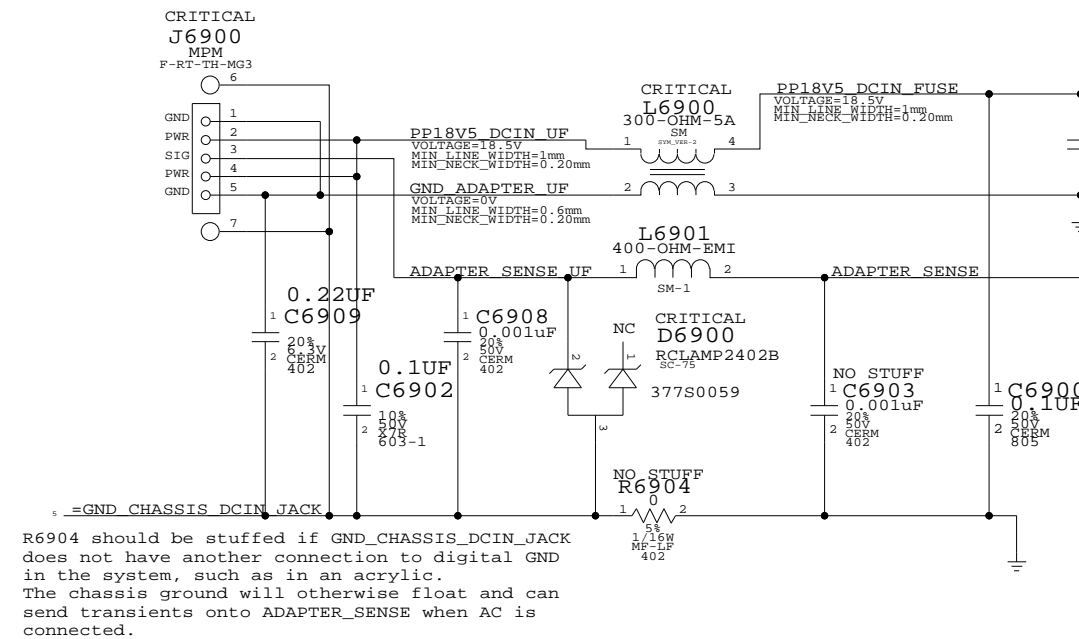

# 1-Wire OverVoltage Protection Q6909

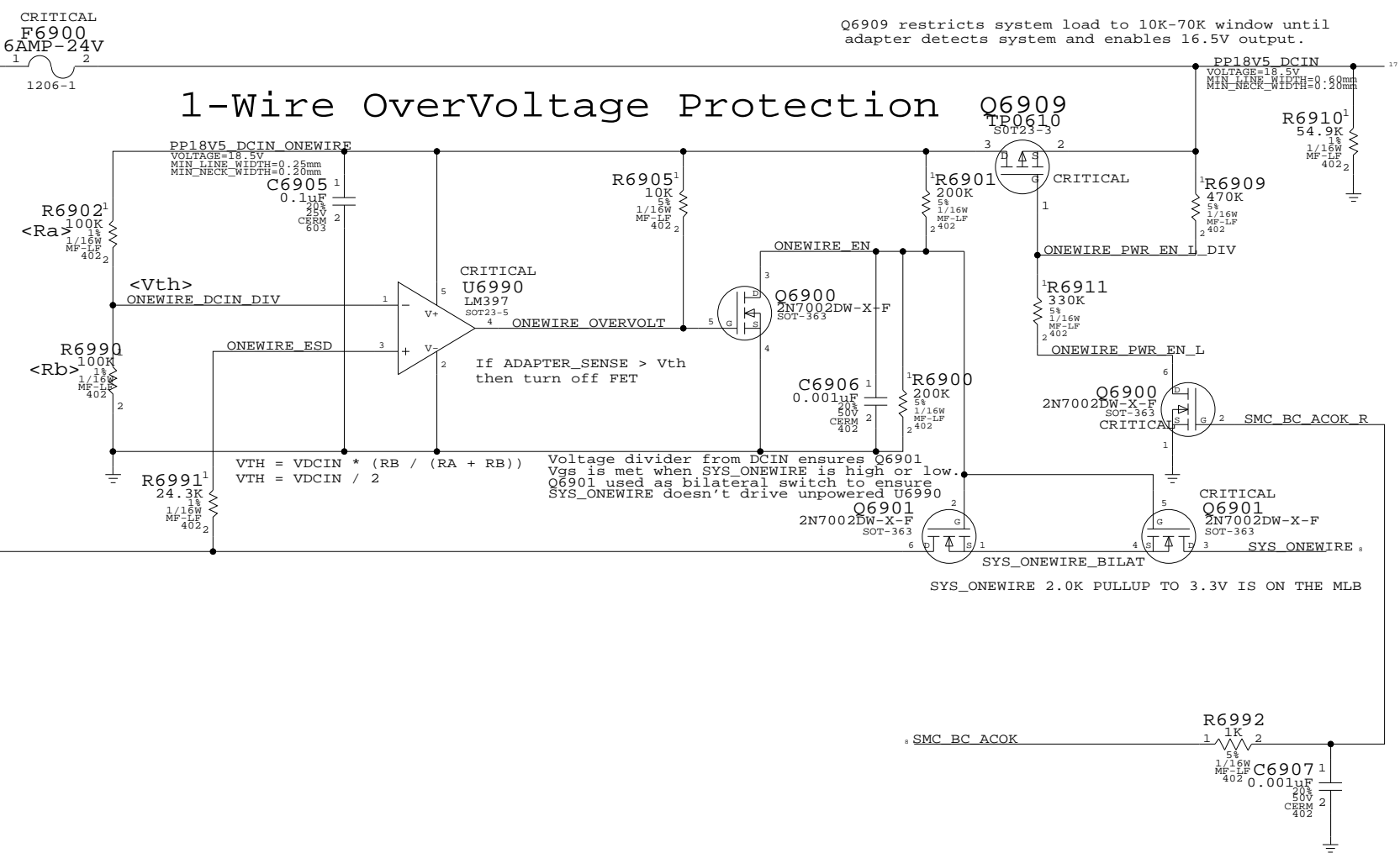

# Left I/O Power Connector

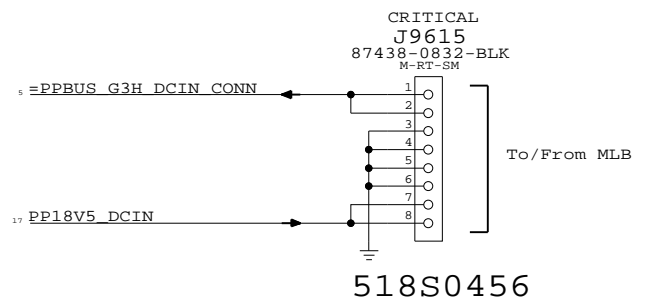

## DC-In & PBUS Connectors

SYNC\_MASTER=(MASTER) SYNC\_DATE=(MASTER)

**NOTICE OF PROPRIETARY PROPERTY**

THE INFORMATION CONTAINED HEREIN IS THE PROPRIETARY PROPERTY OF APPLE COMPUTER, INC. THE POSSESSOR AGREES TO THE FOLLOWING

I TO MAINTAIN THE DOCUMENT IN CONFIDENCE

II NOT TO REPRODUCE OR COPY IT

III NOT TO REVEAL OR PUBLISH IN WHOLE OR PART

APPLE INC.	SIZE	DRAWING NUMBER	REV.
	D	051-7448	A
SCALE	SHT 69 OF 78		
NONE			

# 5V/3.3V POWER SUPPLY

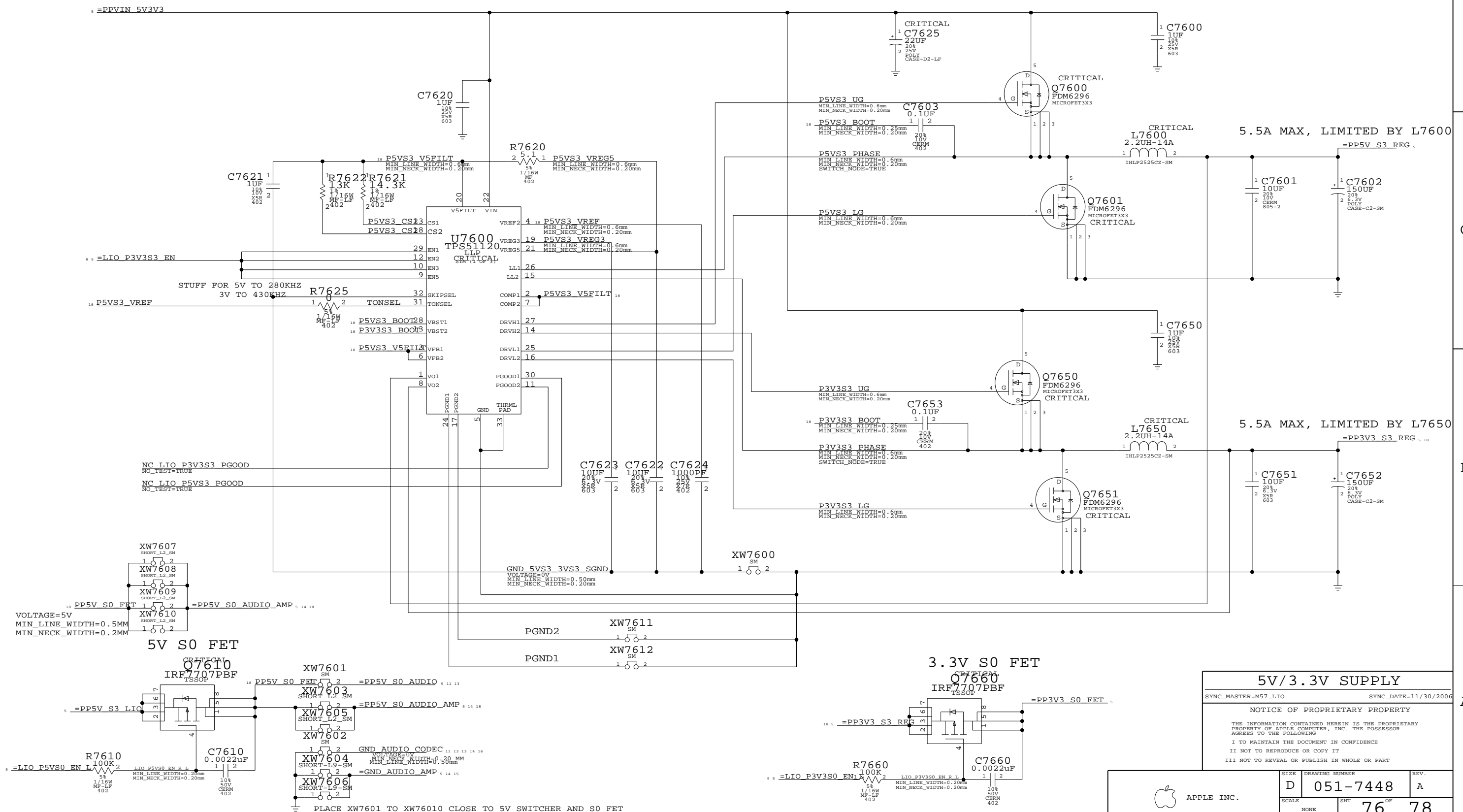

**5V/3.3V SUPPLY**

SYNC\_MASTER=M57\_LIO      SYNC\_DATE=11/30/2006

**NOTICE OF PROPRIETARY PROPERTY**

THE INFORMATION CONTAINED HEREIN IS THE PROPRIETARY PROPERTY OF APPLE COMPUTER, INC. THE POSSESSOR AGREES TO THE FOLLOWING:

I TO MAINTAIN THE DOCUMENT IN CONFIDENCE

II NOT TO REPRODUCE OR COPY IT

III NOT TO REVEAL OR PUBLISH IN WHOLE OR PART

 APPLE INC.	SIZE	DRAWING NUMBER	REV.
	D	051-7448	A
SCALE	SHT	76	78
NONE			

PLACE XW7601 TO XW76010 CLOSE TO 5V SWITCHER AND S0 FET



	8	7	6	5	4	3	2	1
D	Title: Cref Part Report Design: lio Date: Nov 12 10:48:15 2007		C7603 CAP_402 lio[18C3] C7610 CAP_402 lio[18A7] C7620 CAP_603 lio[18C6] C7621 CAP_402 lio[18C7] C7622 CAP_603 lio[18B5] C7623 CAP_603 lio[18B5] C7624 CAP_402 lio[18B5] C7625 CAP_P_CASE-D2-LF lio[18D4] C7650 CAP_603 lio[18B2] C7651 CAP_603 lio[18B2] C7652 CAP_P_CASE-C2-SM lio[18B1] C7653 CAP_402 lio[18B3] C7660 CAP_402 lio[18A3] D4600 DIODE_SCHOT_3P_A_SC- lio[9A3] 75 D4610 DIODE_SCHOT_3P_A_SC- lio[9C4] 75	R5805 RES_402 lio[10C5] R5806 RES_402 lio[10C4] R5807 RES_402 lio[10C4] R5808 THERMISTOR_0603-LF lio[10C6] R6201 RES_402 lio[11B6] R6203 RES_402 lio[11C3] R6204 RES_402 lio[11C7] R6205 RES_402 lio[11B6] R6206 RES_402 lio[11B4] R6207 RES_402 lio[11B3] R6220 RES_402 lio[11A6] R6221 RES_402 lio[11A4] R6222 RES_402 lio[11A4] R6250 RES_402 lio[11C6] R6251 RES_402 lio[11D6] R6300 RES_402 lio[12B3] R6301 RES_402 lio[12B6] R6302 RES_402 lio[12C5] R6303 RES_402 lio[12B5] R6310 RES_402 lio[12C4] R6311 RES_402 lio[12C4] R6312 RES_402 lio[12C4] R6313 RES_402 lio[12C4] R6320 RES_402 lio[12B4] R6321 RES_402 lio[12B4] R6322 RES_402 lio[12B4] R6323 RES_402 lio[12B4] R6500 RES_402 lio[13C5] R6510 RES_402 lio[13B5] R6511 RES_402 lio[13B4] R6512 RES_402 lio[13B4] R6513 RES_603 lio[13C3] R6514 RES_402 lio[13C3] R6520 RES_402 lio[13A5] R6521 RES_402 lio[13A4] R6522 RES_402 lio[13A4] R6523 RES_603 lio[13C3] R6524 RES_402 lio[13C3] R6600 RES_402 lio[14D7] R6601 RES_402 lio[14C6] R6605 RES_402 lio[14C4] R6606 RES_402 lio[14B4] R6607 RES_402 lio[14B4] R6610 RES_402 lio[14D2] R6611 RES_402 lio[14D2] R6620 RES_402 lio[14C2] R6621 RES_402 lio[14C2] R6630 RES_402 lio[14B2] R6631 RES_402 lio[14B2] R6640 RES_402 lio[14B2] R6641 RES_402 lio[14B2] R6710 RES_402 lio[15C4] R6755 RES_402 lio[15B6] R6780 RES_402 lio[15C2] R6781 RES_402 lio[15C1] R6790 RES_402 lio[15A2] R6801 RES_402 lio[16C7] R6802 RES_402 lio[16C7] R6803 RES_402 lio[16C7] R6805 RES_402 lio[16C5] R6806 RES_402 lio[16C6] R6811 RES_402 lio[16A7] R6812 RES_402 lio[16A7] R6813 RES_402 lio[16A7] R6814 RES_402 lio[16A6] R6815 RES_402 lio[16A5] R6840 RES_402 lio[16C3] R6841 RES_402 lio[16B2] R6842 RES_402 lio[16B3] R6843 RES_402 lio[16B3] R6845 RES_402 lio[16C3] R6846 RES_402 lio[16B2] R6850 RES_402 lio[16D2] R6852 RES_402 lio[16C2] R6855 RES_402 lio[16D3] R6861 RES_402 lio[16B7] R6900 RES_402 lio[17C2] R6901 RES_402 lio[17D2] R6902 RES_402 lio[17D5] R6904 RES_402 lio[17C7] R6905 RES_402 lio[17D3] R6909 RES_402 lio[17D1] R6910 RES_402 lio[17D1] R6911 RES_402 lio[17C2] R6990 RES_402 lio[17C5] R6991 RES_402 lio[17C4] R6992 RES_402 lio[17B1] R7610 RES_402 lio[18A8] R7620 RES_402 lio[18C5] R7621 RES_402 lio[18C6] R7622 RES_402 lio[18C7] R7625 RES_402 lio[18C6] R7660 RES_402 lio[18A4] SLO800 SLOT_TH lio[5B8] U3500 FWR_CNTRL_TPS2231_QF lio[7C5] N	XW6712 SHORT_SM lio[15B2] XW6840 SHORT_SM lio[16B3] XW6850 SHORT_SM lio[16C3] XW6851 SHORT_SM lio[16C3] XW7601 SHORT_SM lio[18A4] XW7601 SHORT_SM lio[18A7] XW7602 SHORT_SM lio[18A7] XW7603 SHORT_LAYER_2_SHORT- lio[18A7] L2_SM XW7604 SHORT_LAYER_9_SHORT- lio[18A7] L9-SM XW7605 SHORT_LAYER_2_SHORT- lio[18A7] L2_SM XW7606 SHORT_LAYER_9_SHORT- lio[18A7] L9-SM XW7607 SHORT_LAYER_2_SHORT- lio[18A7] L2_SM XW7608 SHORT_LAYER_2_SHORT- lio[18A7] L2_SM XW7609 SHORT_LAYER_2_SHORT- lio[18A7] L2_SM XW7610 SHORT_LAYER_2_SHORT- lio[18A7] L2_SM XW7611 SHORT_SM lio[18A5] XW7612 SHORT_SM lio[18A5] ZH0801 MTHOLE lio[5A8] ZH0802 MTHOLE lio[5A8] ZH0803 MTHOLE lio[5A8] ZH0804 MTHOLE lio[5A8]	D		
	C	C5802 CAP_402 lio[10C4] C5803 CAP_402 lio[10D5] C5804 CAP_402 lio[10C4] C5805 CAP_402 lio[10A4] C6200 CAP_402 lio[11D6] C6201 CAP_402 lio[11D6] C6203 CAP_402 lio[11D6] C6204 CAP_P_B2 lio[11D4] C6205 CAP_P_B2 lio[11A4] C6206 CAP_402 lio[11D4] C6207 CAP_402 lio[11D3] C6208 CAP_603 lio[11A6] C6209 CAP_402 lio[11A5] C6210 CAP_402 lio[11A6] C6211 CAP_402 lio[11A4] C6220 CAP_402 lio[11B6] C6221 CAP_P_SMA-HF lio[11B4] C6222 CAP_402 lio[11B4] C6300 CAP_402 lio[12C4] C6301 CAP_402 lio[12C4] C6302 CAP_P_CASE-B2 lio[12B3] C6303 CAP_402 lio[12B3] C6310 CAP_P_CASE-R lio[12C5] C6311 CAP_P_CASE-R lio[12C5] C6312 CAP_805-2 lio[12C3] C6320 CAP_P_CASE-R lio[12B5] C6321 CAP_P_CASE-R lio[12B5] C6322 CAP_805-2 lio[12B3] C6500 CAP_0805 lio[13D5] C6501 CAP_402 lio[13D5] C6502 CAP_0805 lio[13C4] C6503 CAP_402 lio[13C5] C6504 CAP_402 lio[13C4] C6510 CAP_P_SMA-HF lio[13B6] C6511 CAP_402 lio[13B4] C6512 CAP_603 lio[13B5] C6520 CAP_P_SMA-HF lio[13A6] C6521 CAP_402 lio[13A4] C6522 CAP_603 lio[13A5] C6600 CAP_P_CASE-B2 lio[14A3] C6601 CAP_P_CASE-B2 lio[14A2] C6610 CAP_402 lio[14B5] C6611 CAP_402 lio[14D4] C6612 CAP_P_CASE-B2 lio[14D4] C6613 CAP_402 lio[14D6] C6614 CAP_402 lio[14C6] C6620 CAP_402 lio[14C5] C6621 CAP_402 lio[14C5] C6622 CAP_P_CASE-B2 lio[14C4] C6623 CAP_402 lio[14C6] C6624 CAP_402 lio[14B6] C6630 CAP_402 lio[14B5] C6631 CAP_402 lio[14B5] C6632 CAP_P_CASE-B2 lio[14B4] C6633 CAP_402 lio[14B6] C6634 CAP_402 lio[14B6] C6640 CAP_402 lio[14A5] C6641 CAP_402 lio[14A5] C6642 CAP_P_CASE-B2 lio[14A4] C6643 CAP_402 lio[14A6] C6644 CAP_402 lio[14A6] C6700 CAP_402 lio[15C7] C6702 CAP_402 lio[15B4] C6750 CAP_402 lio[15A7] C6751 CAP_603 lio[15A7] C6752 CAP_402 lio[15A5] C6800 CAP_402 lio[16B5] C6801 CAP_402 lio[16C7] C6802 CAP_402 lio[16B7] C6811 CAP_402 lio[16A7] C6840 CAP_402 lio[16B3] C6841 CAP_402 lio[16B3] C6842 CAP_402 lio[16B3] C6843 CAP_P_2012-LLP lio[16C3] C6844 CAP_402 lio[16A2] C6845 CAP_402 lio[16A3] C6850 CAP_402 lio[16D3] C6851 CAP_402 lio[16C2] C6852 CAP_402 lio[16C2] C6853 CAP_603 lio[16D2] C6900 CAP_805 lio[17C6] C6903 CAP_402 lio[17C6] C6904 CAP_603 lio[17D6] C6905 CAP_603 lio[17D4] C6906 CAP_402 lio[17C2] C6907 CAP_402 lio[17B1] C7600 CAP_603 lio[18D2] C7601 CAP_805-2 lio[18C2] C7602 CAP_P_CASE-C2-SM lio[18C1]	J4600 CON_F4RT_USB_S2MT_TH lio[9B2] _F-RT-TH-USB-LFT J4610 CON_F4RT_USB_S2MT_TH lio[9C2] _F-RT-TH-USB-LFT J6700 CON_F9RT_SPDIFTRAN_T lio[15C7] H_F-RT-TH J6750 CON_F8RT_SPDIFRCVR_T lio[15B8] H2_F-RT-TH J6780 CON_M3ST_S_TH_M-ST-T lio[15D1] H J6781 CON_M5ST_S_TH_M-ST-T lio[15C1] H J6782 CON_M5ST_S_TH_M-ST-T lio[15C1] H J6900 CON_F5RT_S2MT_TH3_F- lio[17D8] RT-TH-MG3 J9615 CON_MBRT_S_SM-M-RT-S lio[17B5] M L3400 FILTER_4P2_DLP11S lio[6B2] L4600 FILTER_4P2_DLP11S lio[9B4] L4601 IND_0603 lio[9B4] L4610 FILTER_4P2_DLP11S lio[9C4] L4611 IND_0603 lio[9D4] L6200 IND_0402 lio[11A6] L6201 IND_0402 lio[11D7] L6202 IND_0402 lio[11D4] L6300 IND_0402 lio[12C6] L6500 IND_0402 lio[13D6] L6501 IND_0402 lio[13C6] L6601 IND_0402 lio[14C7] L6610 IND_0402 lio[14D7] L6620 IND_0402 lio[14C7] L6630 IND_0402 lio[14B7] L6640 IND_0402 lio[14A7] L6700 IND_0603 lio[15C4] L6701 IND_0402 lio[15C4] L6702 IND_0402 lio[15C4] L6703 IND_0402 lio[15C4] L6704 IND_0402 lio[15D4] L6705 IND_0402 lio[15D4] L6750 IND_0402 lio[15B4] L6751 IND_0402 lio[15A4] L6752 IND_0402 lio[15A4] L6753 IND_0402 lio[15A4] L6754 IND_0402 lio[15A4] L6800 IND_0402 lio[16B5] L6900 FILTER_4P_SM lio[17D7] L6901 IND_SM-1 lio[17D7] L7600 IND_IHLP2525CZ-SM lio[18C2] L7650 IND_IHLP2525CZ-SM lio[18B2] PD5801 PHOTODIODE_2P_TH-WTH lio[10C7] -SPCR Q3450 TRA_SINGLE_MOSFET_PC lio[6D2] HN_SOT-23 Q5801 TRA_2N7002_SOT23-LF lio[10C5] Q6800 TRA_DUAL_SSM6N15FE_S lio[16B7 16C7] OT563 Q6801 TRA_DUAL_SSM6N15FE_S lio[16C5 16C6] OT563 Q6802 TRA_SSM3K15FV_SOD-VE lio[16A7] SM Q6803 TRA_DUAL_SSM6N15FE_S lio[16A5 16A6] OT563 Q6840 TRA_SSM3K15FV_SOD-VE lio[16B2] SM Q6841 TRA_SSM3J16FV_SOD-VE lio[16B3] SM Q6900 TRA_2N7002DW_SOT-363 lio[17C1 17C3] Q6901 TRA_2N7002DW_SOT-363 lio[17C1 17C2] Q6909 TRA_TP0610_SOT23-3 lio[17D2] Q7600 TRA_FDM6296_MICROFET lio[18C3] 3X3 Q7601 TRA_FDM6296_MICROFET lio[18C3] 3X3 Q7610 TRA_IRF7707_TSSOP lio[18A7] Q7650 TRA_FDM6296_MICROFET lio[18B3] 3X3 Q7651 TRA_FDM6296_MICROFET lio[18B3] 3X3 Q7660 TRA_IRF7707_TSSOP lio[18A3] R3450 RES_402 lio[6C2] R3451 RES_402 lio[6C2] R3500 RES_402 lio[7C6] R3561 RES_402 lio[7B3] R5801 RES_402 lio[10C6] R5802 RES_402 lio[10C6] R5803 RES_402 lio[10C5] R5804 RES_402 lio[10C5]	U3551 MC74VHC1G00_SCT0-5 lio[7A6] U3560 MC74VHC1G00_SCT0-5 lio[7B2] U3561 SN74LVCG04_BGA lio[7A3] U4600 SWI_TPS2060_MSOP lio[9B7] U5801 OPAMP_MAX4236EUTT_SO lio[10C5] T23-6-LF U5802 TMP102_SOT563 lio[10B5] U6200 ADR10_ALC885B2_LQFP lio[11C5] U6201 L8951_TPS79501DBW_BOM lio[11A5] U6300 OPAMP_MAX4253_UMAX lio[12B4 12C4] U6500 MAX9724A_TQFN lio[13C5] U6610 MAX9705_TDFN1 lio[14D5] U6620 MAX9705_TDFN1 lio[14C5] U6630 MAX9705_TDFN1 lio[14B5] U6640 MAX9705_TDFN1 lio[14A5] U6990 COMPARATOR_LM397_SOT lio[17C4] 23-5 U7600 TP5S1120_LLP lio[18C6] XW4500 SHORT_SM lio[9A4] XW4601 SHORT_SM lio[9A4] XW4610 SHORT_SM lio[9C4] XW4611 SHORT_SM lio[9C4] XW6200 SHORT_SM lio[11A7] XW6201 SHORT_SM lio[11A6] XW6500 SHORT_SM lio[13C6] XW6501 SHORT_SM lio[13B6] XW6710 SHORT_SM lio[15B2] XW6711 SHORT_SM lio[15B2]	C			
B	B							
A	Title: Cref Part Report Design: lio Date: Nov 12 10:48:15 2007		C7603 CAP_402 lio[18C3] C7610 CAP_402 lio[18A7] C7620 CAP_603 lio[18C6] C7621 CAP_402 lio[18C7] C7622 CAP_603 lio[18B5] C7623 CAP_603 lio[18B5] C7624 CAP_402 lio[18B5] C7625 CAP_P_CASE-D2-LF lio[18D4] C7650 CAP_603 lio[18B2] C7651 CAP_603 lio[18B2] C7652 CAP_P_CASE-C2-SM lio[18B1] C7653 CAP_402 lio[18B3] C7660 CAP_402 lio[18A3] D4600 DIODE_SCHOT_3P_A_SC- lio[9A3] 75 D4610 DIODE_SCHOT_3P_A_SC- lio[9C4] 75	R5805 RES_402 lio[10C5] R5806 RES_402 lio[10C4] R5807 RES_402 lio[10C4] R5808 THERMISTOR_0603-LF lio[10C6] R6201 RES_402 lio[11B6] R6203 RES_402 lio[11C3] R6204 RES_402 lio[11C7] R6205 RES_402 lio[11B6] R6206 RES_402 lio[11B4] R6207 RES_402 lio[11B3] R6220 RES_402 lio[11A6] R6221 RES_402 lio[11A4] R6222 RES_402 lio[11A4] R6250 RES_402 lio[11C6] R6251 RES_402 lio[11D6] R6300 RES_402 lio[12B3] R6301 RES_402 lio[12B6] R6302 RES_402 lio[12C5] R6303 RES_402 lio[12B5] R6310 RES_402 lio[12C4] R6311 RES_402 lio[12C4] R6312 RES_402 lio[12C4] R6313 RES_402 lio[12C4] R6320 RES_402 lio[12B4] R6321 RES_402 lio[12B4] R6322 RES_402 lio[12B4] R6323 RES_402 lio[12B4] R6500 RES_402 lio[13C5] R6510 RES_402 lio[13B5] R6511 RES_402 lio[13B4] R6512 RES_402 lio[13B4] R6513 RES_603 lio[13C3] R6514 RES_402 lio[13C3] R6520 RES_402 lio[13A5] R6521 RES_402 lio[13A4] R6522 RES_402 lio[13A4] R6523 RES_603 lio[13C3] R6524 RES_402 lio[13C3] R6600 RES_402 lio[14D7] R6601 RES_402 lio[14C6] R6605 RES_402 lio[14C4] R6606 RES_402 lio[14B4] R6607 RES_402 lio[14B4] R6610 RES_402 lio[14D2] R6611 RES_402 lio[14D2] R6620 RES_402 lio[14C2] R6621 RES_402 lio[14C2] R6630 RES_402 lio[14B2] R6631 RES_402 lio[14B2] R6640 RES_402 lio[14B2] R6641 RES_402 lio[14B2] R6710 RES_402 lio[15C4] R6755 RES_402 lio[15B6] R6780 RES_402 lio[15C2] R6781 RES_402 lio[15C1] R6790 RES_402 lio[15A2] R6801 RES_402 lio[16C7] R6802 RES_402 lio[16C7] R6803 RES_402 lio[16C7] R6805 RES_402 lio[16C5] R6806 RES_402 lio[16C6] R6811 RES_402 lio[16A7] R6812 RES_402 lio[16A7] R6813 RES_402 lio[16A7] R6814 RES_402 lio[16A6] R6815 RES_402 lio[16A5] R6840 RES_402 lio[16C3] R6841 RES_402 lio[16B2] R6842 RES_402 lio[16B3] R6843 RES_402 lio[16B3] R6845 RES_402 lio[16C3] R6846 RES_402 lio[16B2] R6850 RES_402 lio[16D2] R6852 RES_402 lio[16C2] R6855 RES_402 lio[16D3] R6861 RES_402 lio[16B7] R6900 RES_402 lio[17C2] R6901 RES_402 lio[17D2] R6902 RES_402 lio[17D5] R6904 RES_402 lio[17C7] R6905 RES_402 lio[17D3] R6909 RES_402 lio[17D1] R6910 RES_402 lio[17D1] R6911 RES_402 lio[17C2] R6990 RES_402 lio[17C5] R6991 RES_402 lio[17C4] R6992 RES_402 lio[17B1] R7610 RES_402 lio[18A8] R7620 RES_402 lio[18C5] R7621 RES_402 lio[18C6] R7622 RES_402 lio[18C7] R7625 RES_402 lio[18C6] R7660 RES_402 lio[18A4] SLO800 SLOT_TH lio[5B8] U3500 FWR_CNTRL_TPS2231_QF lio[7C5] N	XW6712 SHORT_SM lio[15B2] XW6840 SHORT_SM lio[16B3] XW6850 SHORT_SM lio[16C3] XW6851 SHORT_SM lio[16C3] XW7601 SHORT_SM lio[18A4] XW7601 SHORT_SM lio[18A7] XW7602 SHORT_SM lio[18A7] XW7603 SHORT_LAYER_2_SHORT- lio[18A7] L2_SM XW7604 SHORT_LAYER_9_SHORT- lio[18A7] L9-SM XW7605 SHORT_LAYER_2_SHORT- lio[18A7] L2_SM XW7606 SHORT_LAYER_9_SHORT- lio[18A7] L9-SM XW7607 SHORT_LAYER_2_SHORT- lio[18A7] L2_SM XW7608 SHORT_LAYER_2_SHORT- lio[18A7] L2_SM XW7609 SHORT_LAYER_2_SHORT- lio[18A7] L2_SM XW7610 SHORT_LAYER_2_SHORT- lio[18A7] L2_SM XW7611 SHORT_SM lio[18A5] XW7612 SHORT_SM lio[18A5] ZH0801 MTHOLE lio[5A8] ZH0802 MTHOLE lio[5A8] ZH0803 MTHOLE lio[5A8] ZH0804 MTHOLE lio[5A8]	A		
	A	A						