

8

7

6

5

4

3

2

1

- 1. ALL RESISTANCE VALUES ARE IN OHMS, 0.1 WATT +/- 5%.
- 2. ALL CAPACITANCE VALUES ARE IN MICROFARADS.
- 3. ALL CRYSTALS & OSCILLATOR VALUES ARE IN HERTZ.

DOH-RUN

Getting the LED out of Oroya
11/01/2006

REV	ZONE	ECN	DESCRIPTION OF CHANGE	CK APPD	ENG APPD
?		?	?		
				DATE	DATE

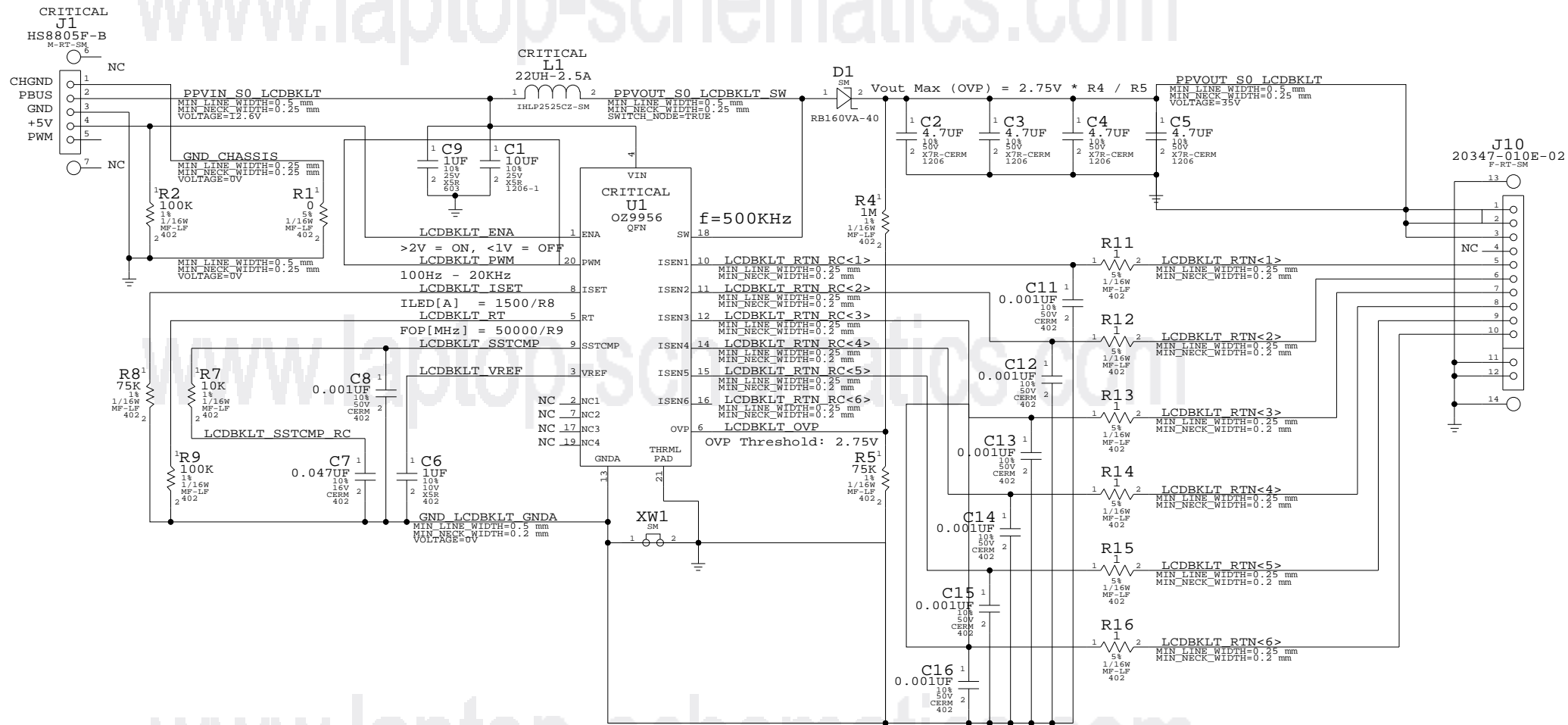

PART NUMBER	QTY	DESCRIPTION	REFERENCE DES	CRITICAL	BOM OPTION
051-7271	1	SCHEM, DOH-RUN, M75	SCH1	CRITICAL	
820-2142	1	PCBF, DOH-RUN, M75	PCB1	CRITICAL	

DIMENSIONS ARE IN MILLIMETERS		METRIC		Apple Computer Inc.	
XX :	_____	DRAPTR	DESIGN CK	NOTICE OF PROPRIETARY PROPERTY THE INFORMATION CONTAINED HEREIN IS THE PROPRIETARY PROPERTY OF APPLE COMPUTER, INC. THE POSSESSOR AGREES TO THE FOLLOWING: I TO MAINTAIN THE DOCUMENT IN CONFIDENCE II NOT TO REPRODUCE OR COPY IT III NOT TO REVEAL OR PUBLISH IN WHOLE OR PART	
X.XX :	_____	ENG APPD	MFG APPD		
X.XXX :	_____	QA APPD	DESIGNER		
ANGLES :	_____	RELEASE	SCALE		
DO NOT SCALE DRAWING		MATERIAL/FINISH NOTED AS APPLICABLE		TITLE	
 THIRD ANGLE PROJECTION		SIZE D		DRAWING NUMBER 051-7271 REV. 0.1.0	
				SHT 1 OF 1	

D

C

B

A

D

C

B

A

www.laptop-schematics.com

www.laptop-schematics.com