

Compal Confidential

NCWGO/H0 Schematics Document

AMD S1g1 / RS780MN/ SB710

2009 / 06 / 24

LA-5481

Rev:1.0

Security Classification	Compal Secret Data			Compal Electronics, Inc.		
Issued Date	2005/03/08	Deciphered Date	2010/03/12	Title	SCHEMATIC, MB A5481	
THIS SHEET OF ENGINEERING DRAWING IS THE PROPRIETARY PROPERTY OF COMPAL ELECTRONICS, INC. AND CONTAINS CONFIDENTIAL AND TRADE SECRET INFORMATION. THIS SHEET MAY NOT BE TRANSFERRED FROM THE CUSTODY OF THE COMPETENT DIVISION OF R&D DEPARTMENT EXCEPT AS AUTHORIZED BY COMPAL ELECTRONICS, INC. NEITHER THIS SHEET NOR THE INFORMATION IT CONTAINS MAY BE USED BY OR DISCLOSED TO ANY THIRD PARTY WITHOUT PRIOR WRITTEN CONSENT OF COMPAL ELECTRONICS, INC.				Size	Document Number	Rev
				Custom	401743	C
				Date	Wednesday, June 24, 2009	Sheet 1 of 47

Compal confidential

Project Code: NCWG0/H0

File Name : LA-5481P

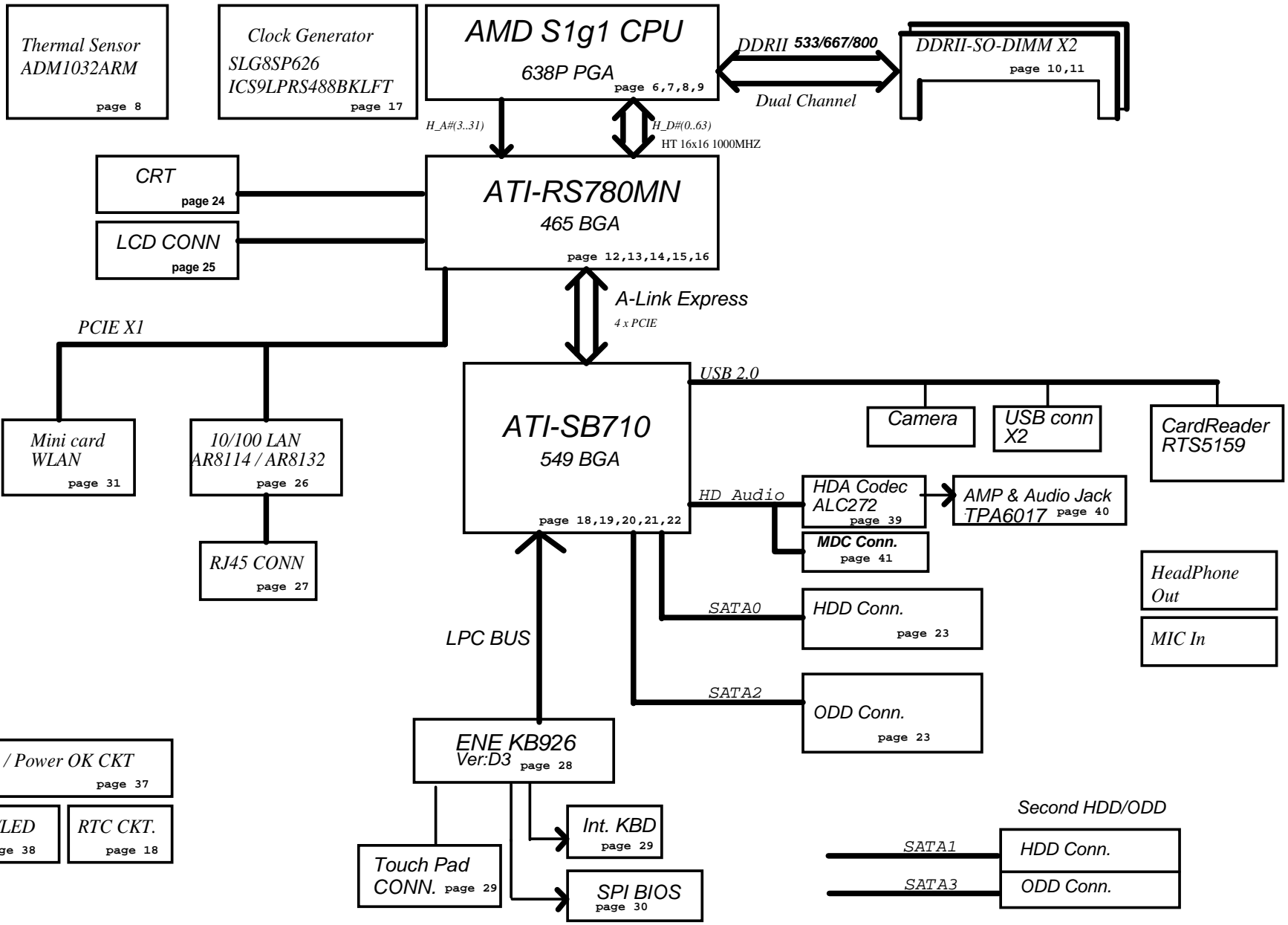

Power On/Off CKT / LID switch / Power OK CKT page 37

DC/DC Interface CKT. page 41

CIR/LED page 38

RTC CKT. page 18

Power Circuit DC/DC page 42-48

Security Classification		Compal Secret Data		Compal Electronics, Inc.	
Issued Date	2009/03/08	Deciphered Date	2010/03/12	Title	
THIS SHEET OF ENGINEERING DRAWING IS THE PROPRIETARY PROPERTY OF COMPAL ELECTRONICS, INC. AND CONTAINS CONFIDENTIAL AND TRADE SECRET INFORMATION. THIS SHEET MAY NOT BE TRANSFERRED FROM THE CUSTODY OF THE COMPETENT DIVISION OF R&D DEPARTMENT EXCEPT AS AUTHORIZED BY COMPAL ELECTRONICS, INC. NEITHER THIS SHEET NOR THE INFORMATION IT CONTAINS MAY BE USED BY OR DISCLOSED TO ANY THIRD PARTY WITHOUT PRIOR WRITTEN CONSENT OF COMPAL ELECTRONICS, INC.				Size	Document Number
				Customer	401743
				Date:	Wednesday, June 24, 2009
				Sheet	2 of 47
				Rev	C

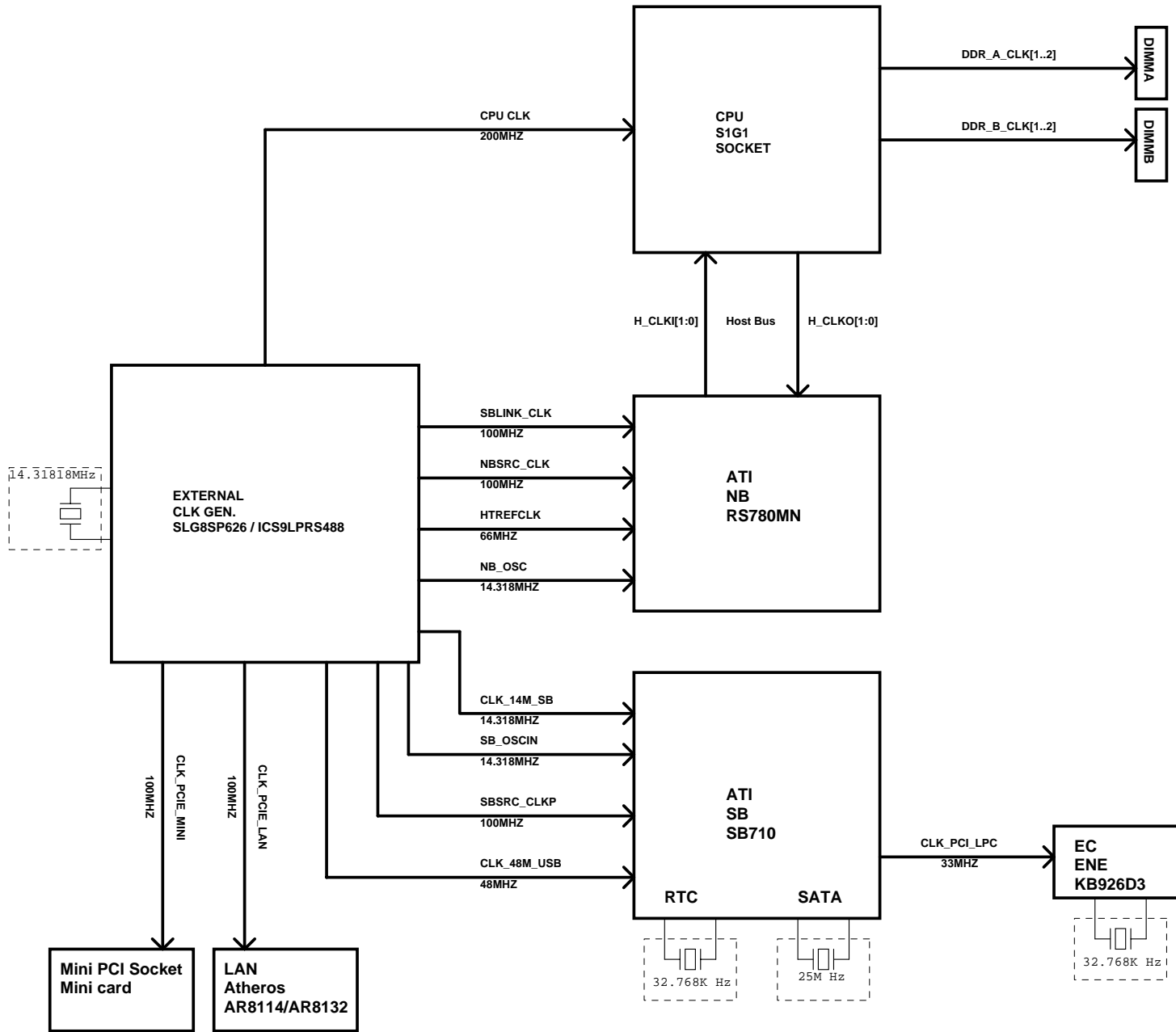

Security Classification		Compal Secret Data		Compal Electronics, Inc.	
Issued Date	2005/10/10	Deciphered Date	2010/03/12	Title	
THIS SHEET OF ENGINEERING DRAWING IS THE PROPRIETARY PROPERTY OF COMPAL ELECTRONICS, INC. AND CONTAINS CONFIDENTIAL AND TRADE SECRET INFORMATION. THIS SHEET MAY NOT BE TRANSFERRED FROM THE CUSTODY OF THE COMPETENT DIVISION OF R&D DEPARTMENT EXCEPT AS AUTHORIZED BY COMPAL ELECTRONICS, INC. NEITHER THIS SHEET NOR THE INFORMATION IT CONTAINS MAY BE USED BY OR DISCLOSED TO ANY THIRD PARTY WITHOUT PRIOR WRITTEN CONSENT OF COMPAL ELECTRONICS, INC.				Size	Document Number
				Customer	401743
				Date:	Wednesday, June 24, 2009
				Sheet	4 of 47
				Rev	C

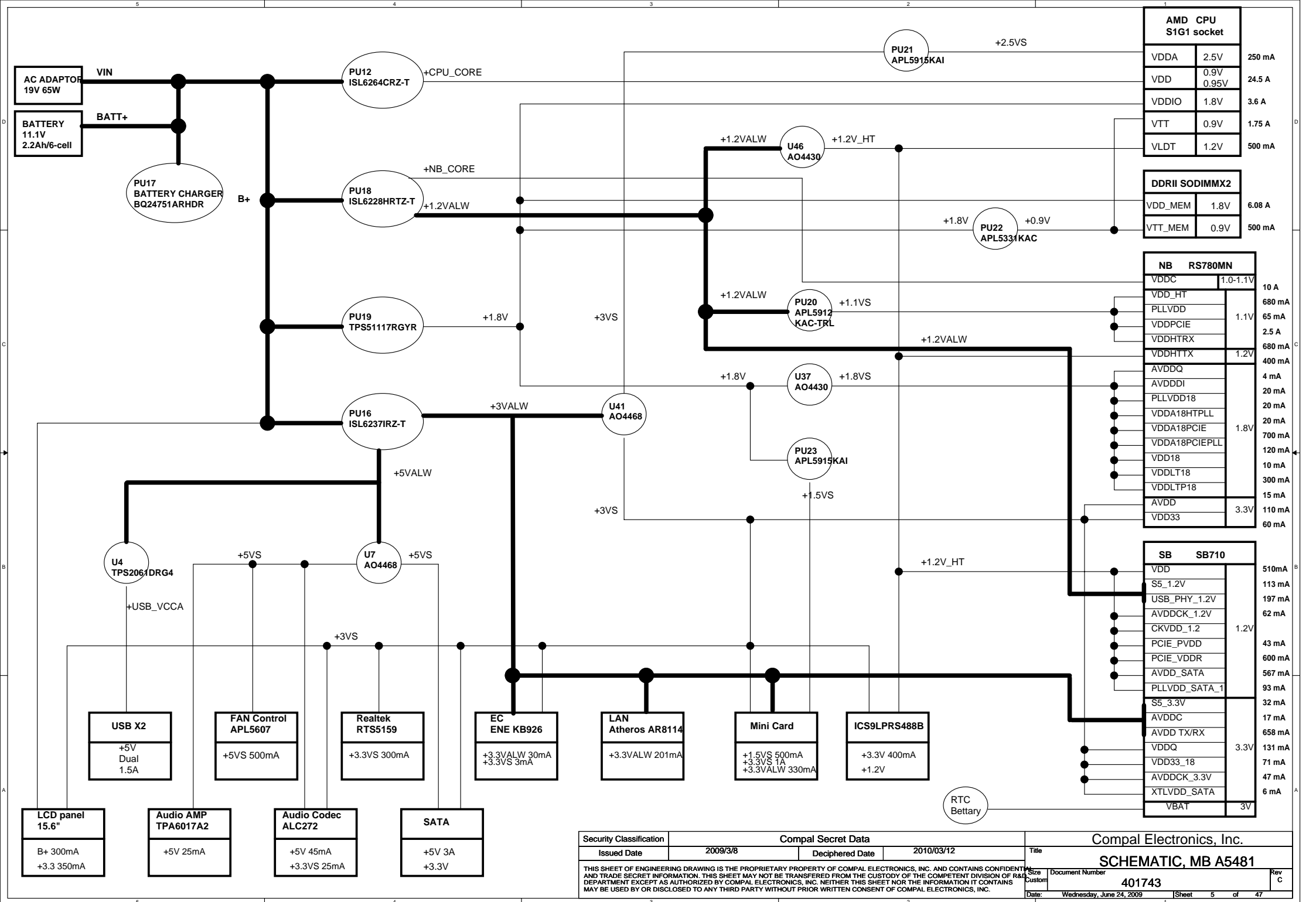

AMD CPU S1G1 socket		
VDDA	2.5V	250 mA
VDD	0.9V / 0.95V	24.5 A
VDDIO	1.8V	3.6 A
VTT	0.9V	1.75 A
VLDT	1.2V	500 mA

DDRII SODIMM2		
VDD_MEM	1.8V	6.08 A
VTT_MEM	0.9V	500 mA

NB RS780MN		
VDDC	1.0-1.1V	10 A
VDD_HT		680 mA
PLLVDD	1.1V	2.5 A
VDDPCIE		65 mA
VDDHTRX		680 mA
VDDHTX	1.2V	400 mA
AVDDQ		4 mA
AVDDDI		20 mA
PLLVDD18	1.8V	20 mA
VDDA18HTPLL		20 mA
VDDA18PCIE		700 mA
VDDA18PCIEPLL		120 mA
VDD18		10 mA
VDDLTP18		300 mA
AVDD		15 mA
VDD33	3.3V	110 mA

SB SB710		
VDD		510 mA
S5_1.2V		113 mA
USB_PHY_1.2V		197 mA
AVDDCK_1.2V	1.2V	62 mA
CKVDD_1.2		43 mA
PCIE_PVDD		600 mA
PCIE_VDDR		567 mA
AVDD_SATA		93 mA
PLLVDD_SATA_1		32 mA
S5_3.3V		17 mA
AVDDC		658 mA
AVDD TX/RX		131 mA
VDDQ	3.3V	71 mA
VDD33_18		47 mA
AVDDCK_3.3V		6 mA
XTLVDD_SATA		
VBAT	3V	

Security Classification	Compal Secret Data		Title	Compal Electronics, Inc.	
Issued Date	2009/3/8	Deciphered Date	2010/03/12	Size	Document Number
THIS SHEET OF ENGINEERING DRAWING IS THE PROPRIETARY PROPERTY OF COMPAL ELECTRONICS, INC. AND CONTAINS CONFIDENTIAL AND TRADE SECRET INFORMATION. THIS SHEET MAY NOT BE TRANSFERRED FROM THE CUSTODY OF THE COMPETENT DIVISION OF R&D DEPARTMENT EXCEPT AS AUTHORIZED BY COMPAL ELECTRONICS, INC. NEITHER THIS SHEET NOR THE INFORMATION IT CONTAINS MAY BE USED BY OR DISCLOSED TO ANY THIRD PARTY WITHOUT PRIOR WRITTEN CONSENT OF COMPAL ELECTRONICS, INC.			Date:	Wednesday, June 24, 2009	Sheet 5 of 47
				401743	Rev C

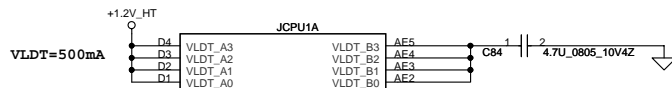

H_CADIP15 N5	L0_CADIN_H15	L0_CADOUT_H15	T4 H_CADOP15
H_CADIP15 P6	L0_CADIN_L15	L0_CADOUT_L15	T3 H_CADON15
H_CADIP14 M3	L0_CADIN_H14	L0_CADOUT_H14	V6 H_CADOP14
H_CADIP14 M4	L0_CADIN_L14	L0_CADOUT_L14	V5 H_CADON14
H_CADIP13 L5	L0_CADIN_H13	L0_CADOUT_H13	V4 H_CADOP13
H_CADIP13 M5	L0_CADIN_L13	L0_CADOUT_L13	V3 H_CADON13
H_CADIP12 K3	L0_CADIN_H12	L0_CADOUT_H12	V6 H_CADOP12
H_CADIP12 K4	L0_CADIN_L12	L0_CADOUT_L12	V5 H_CADON12
H_CADIP11 H3	L0_CADIN_H11	L0_CADOUT_H11	AB5 H_CADOP11
H_CADIP11 H4	L0_CADIN_L11	L0_CADOUT_L11	AB4 H_CADON11
H_CADIP10 G5	L0_CADIN_H10	L0_CADOUT_H10	AB3 H_CADOP10
H_CADIP10 G6	L0_CADIN_L10	L0_CADOUT_L10	AB2 H_CADON10
H_CADIP9 E3	L0_CADIN_H9	L0_CADOUT_H9	AD5 H_CADOP9
H_CADIP9 E4	L0_CADIN_L9	L0_CADOUT_L9	AD4 H_CADON9
H_CADIP8 E5	L0_CADIN_H8	L0_CADOUT_H8	AD3 H_CADOP8
H_CADIP8 E6	L0_CADIN_L8	L0_CADOUT_L8	AD2 H_CADON8
H_CADIP7 N3	L0_CADIN_H7	L0_CADOUT_H7	T1 H_CADOP7
H_CADIP7 N4	L0_CADIN_L7	L0_CADOUT_L7	T0 H_CADON7
H_CADIP6 L1	L0_CADIN_H6	L0_CADOUT_H6	U2 H_CADOP6
H_CADIP6 M1	L0_CADIN_L6	L0_CADOUT_L6	U1 H_CADON6
H_CADIP5 L2	L0_CADIN_H5	L0_CADOUT_H5	W3 H_CADOP5
H_CADIP5 L3	L0_CADIN_L5	L0_CADOUT_L5	W2 H_CADON5
H_CADIP4 J1	L0_CADIN_H4	L0_CADOUT_H4	W3 H_CADOP4
H_CADIP4 K1	L0_CADIN_L4	L0_CADOUT_L4	W2 H_CADON4
H_CADIP3 G1	L0_CADIN_H3	L0_CADOUT_H3	AA2 H_CADOP3
H_CADIP3 H1	L0_CADIN_L3	L0_CADOUT_L3	AA1 H_CADON3
H_CADIP2 G2	L0_CADIN_H2	L0_CADOUT_H2	AB1 H_CADOP2
H_CADIP2 G3	L0_CADIN_L2	L0_CADOUT_L2	AA1 H_CADON2
H_CADIP1 E1	L0_CADIN_H1	L0_CADOUT_H1	AC2 H_CADOP1
H_CADIP0 E3	L0_CADIN_H0	L0_CADOUT_H0	AC3 H_CADON1
H_CADIN0 E2	L0_CADIN_L0	L0_CADOUT_L0	AD1 H_CADOP0
			AC1 H_CADON0

HIT Interface

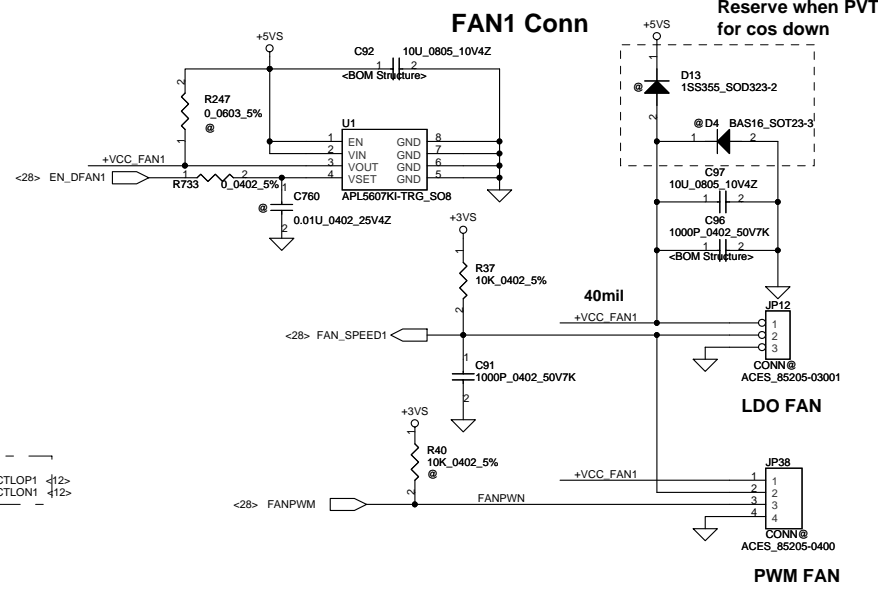
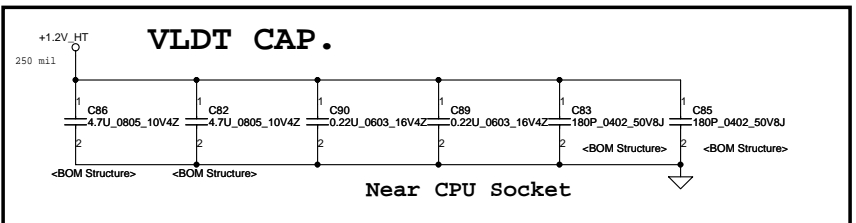
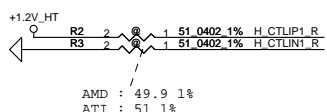
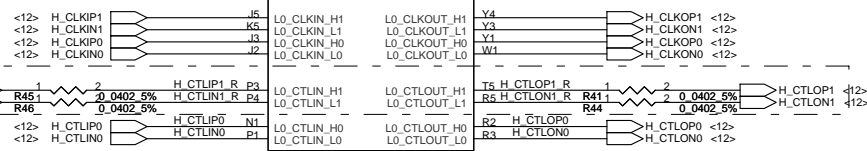

Security Classification	Compal Secret Data			Title	Compal Electronics, Inc.	
Issued Date	2007/5/18	Deciphered Date	2010/03/12	Document Number	SCHEMATIC, MB A5481	
THIS SHEET OF ENGINEERING DRAWING IS THE PROPRIETARY PROPERTY OF COMPAL ELECTRONICS, INC. AND CONTAINS CONFIDENTIAL AND TRADE SECRET INFORMATION. THIS SHEET MAY NOT BE TRANSFERRED FROM THE CUSTODY OF THE COMPETENT DIVISION OF R&D DEPARTMENT EXCEPT AS AUTHORIZED BY COMPAL ELECTRONICS, INC. NEITHER THIS SHEET NOR THE INFORMATION IT CONTAINS MAY BE USED BY OR DISCLOSED TO ANY THIRD PARTY WITHOUT PRIOR WRITTEN CONSENT OF COMPAL ELECTRONICS, INC.				Date	Wednesday, June 24, 2009	Rev C
				Sheet	6	of 46

Processor DDR2 Memory Interface

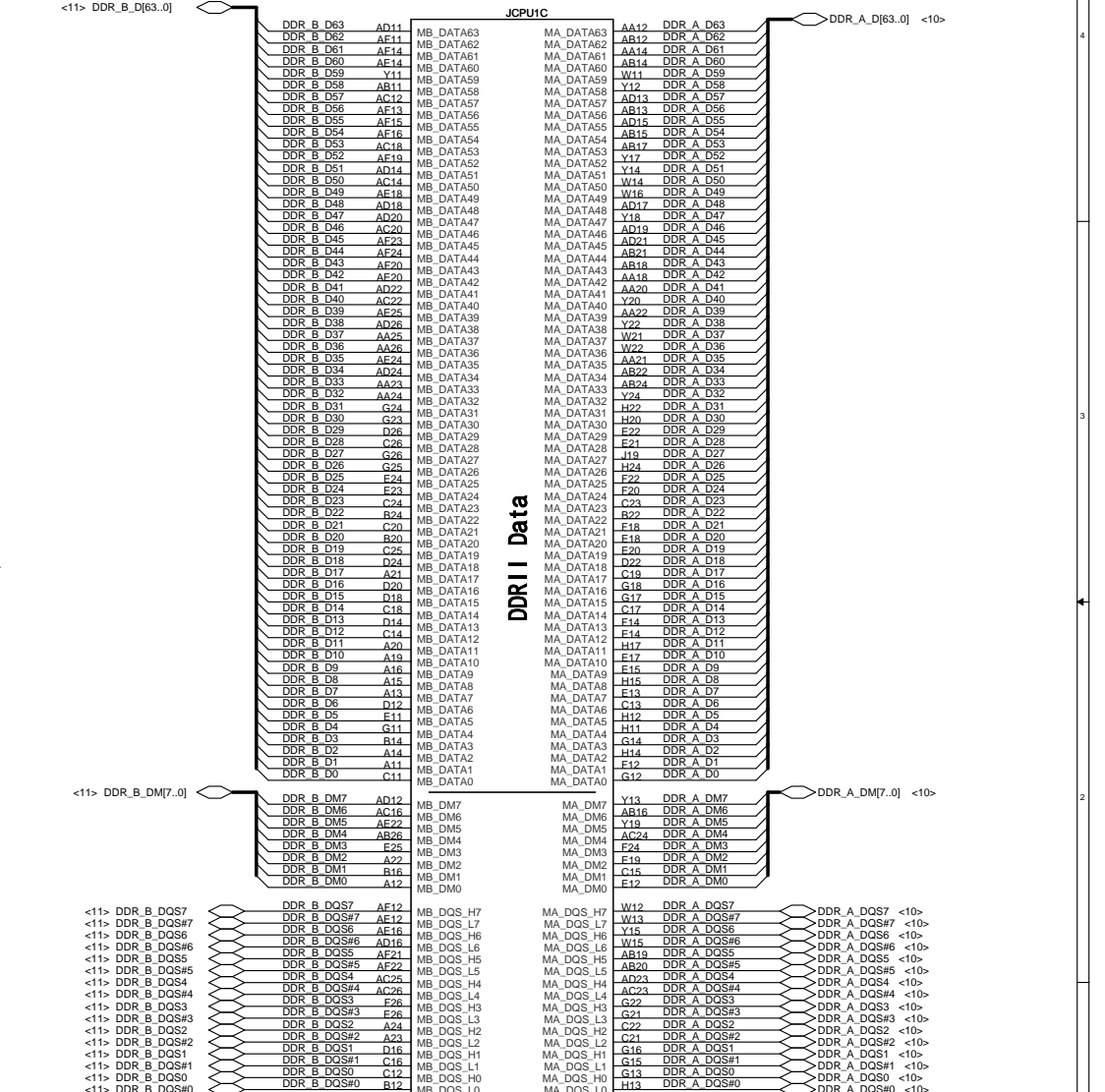
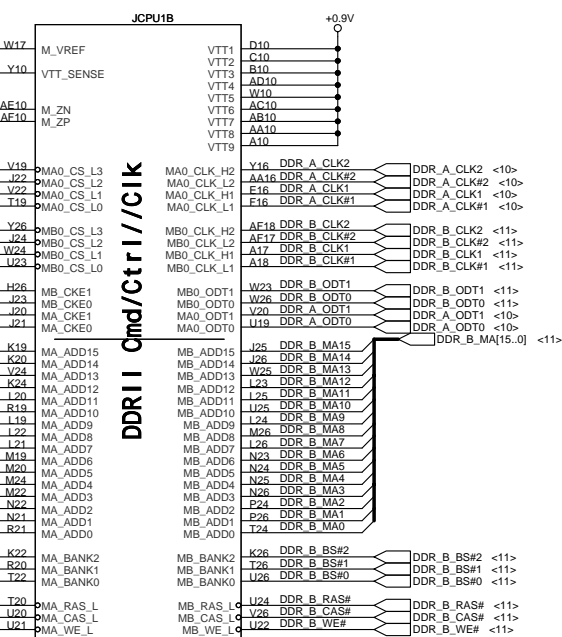
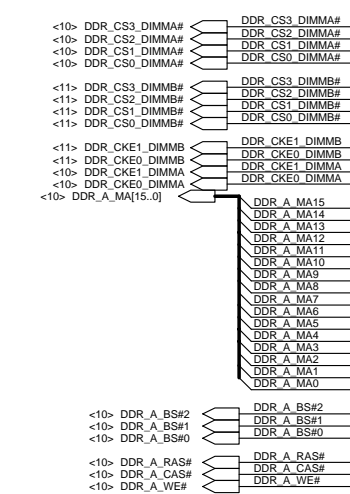
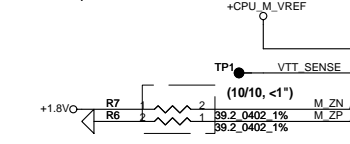
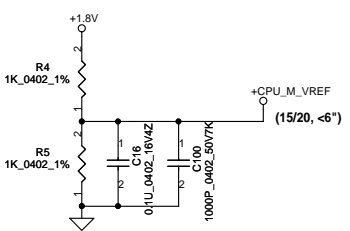

PLACE CLOSE TO PROCESSOR
WITHIN 1.5 INCH

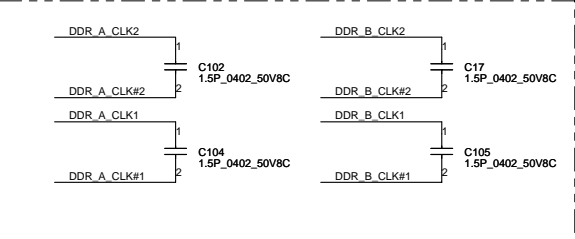

CONN@ FOX_P263823-284S-41F
Athlon 64 S1
Processor Socket

Security Classification	Compal Secret Data			Compal Electronics, Inc.	
Issued Date	2007/5/18	Deciphered Date	2010/03/12	Title	SCHEMATIC, MB A5481
THIS SHEET OF ENGINEERING DRAWING IS THE PROPRIETARY PROPERTY OF COMPAL ELECTRONICS, INC. AND CONTAINS CONFIDENTIAL AND TRADE SECRET INFORMATION. THIS SHEET MAY NOT BE TRANSFERRED FROM THE CUSTODY OF THE COMPETENT DIVISION OR DEPARTMENT EXCEPT AS AUTHORIZED BY COMPAL ELECTRONICS, INC. NEITHER THIS SHEET NOR THE INFORMATION IT CONTAINS MAY BE USED BY OR DISCLOSED TO ANY THIRD PARTY WITHOUT PRIOR WRITTEN CONSENT OF COMPAL ELECTRONICS, INC.					
Customer	401743	Rev	0.1	Date:	Wednesday, June 24, 2009
Sheet	7	of	46		

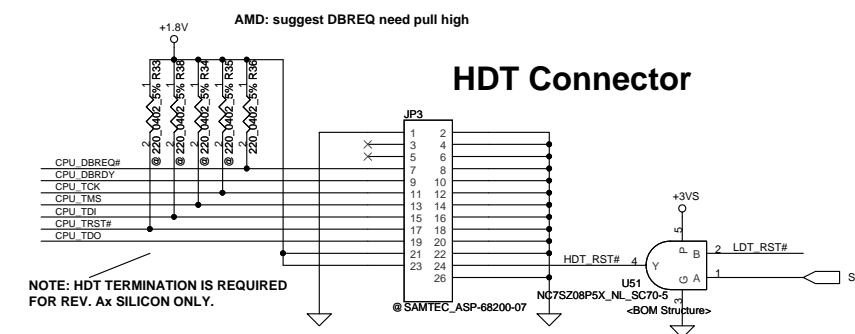
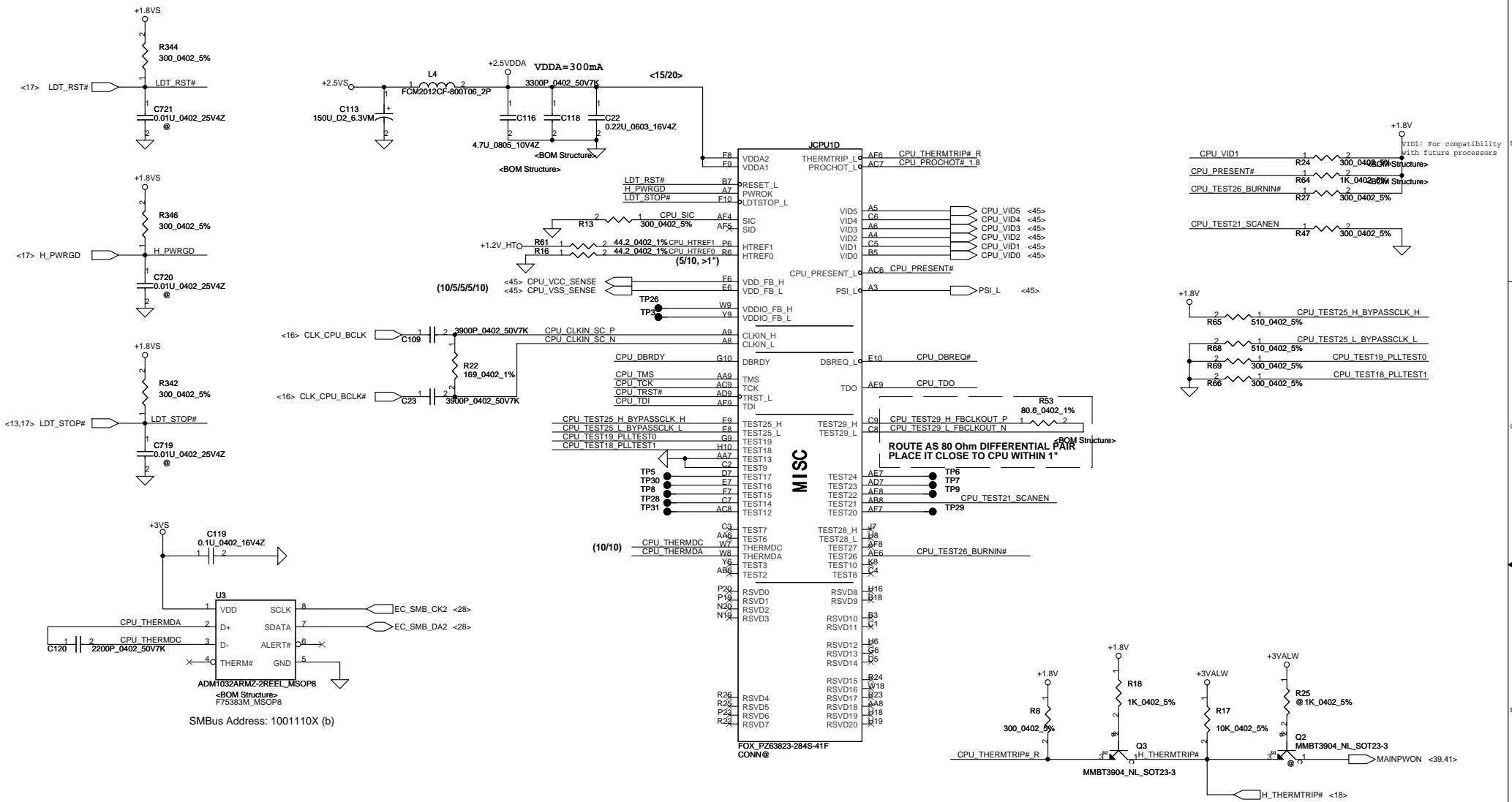

Security Classification	Compal Secret Data			Title
Issued Date	2007/5/18	Deciphered Date	2010/03/12	Compal Electronics, Inc.
THIS SHEET OF ENGINEERING DRAWING IS THE PROPRIETARY PROPERTY OF COMPAL ELECTRONICS, INC. AND CONTAINS CONFIDENTIAL AND TRADE SECRET INFORMATION. THIS SHEET MAY NOT BE TRANSFERRED FROM THE CUSTODY OF THE COMPETENT DIVISION OF R&D DEPARTMENT EXCEPT AS AUTHORIZED BY COMPAL ELECTRONICS, INC. NEITHER THIS SHEET NOR THE INFORMATION IT CONTAINS MAY BE USED BY OR DISCLOSED TO ANY THIRD PARTY WITHOUT PRIOR WRITTEN CONSENT OF COMPAL ELECTRONICS, INC.				Document Number
				401743
				Rev C
				Date: Wednesday, June 24, 2009
				Sheet 8 of 46

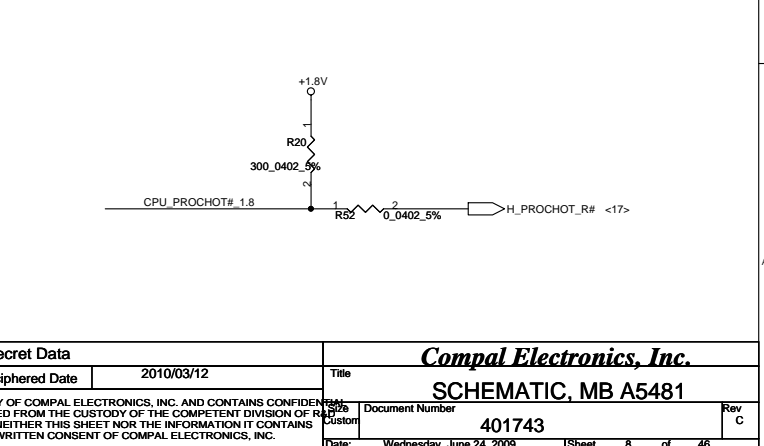
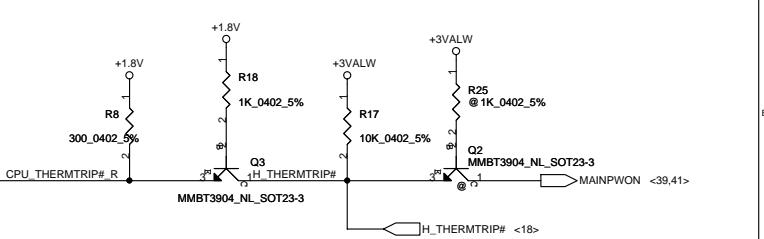
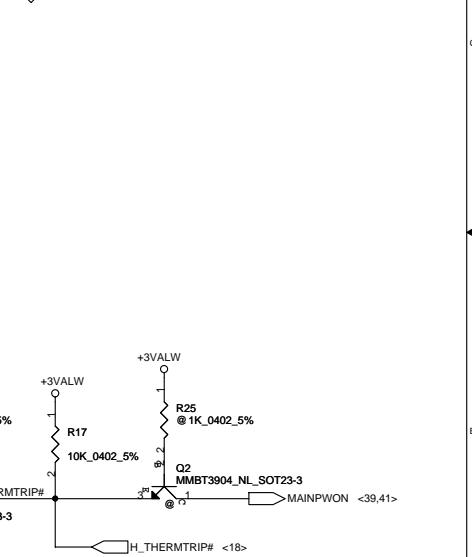
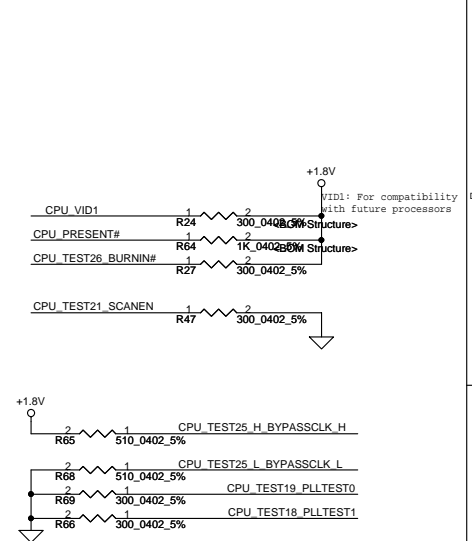

VDD(+CPU_CORE) decoupling.

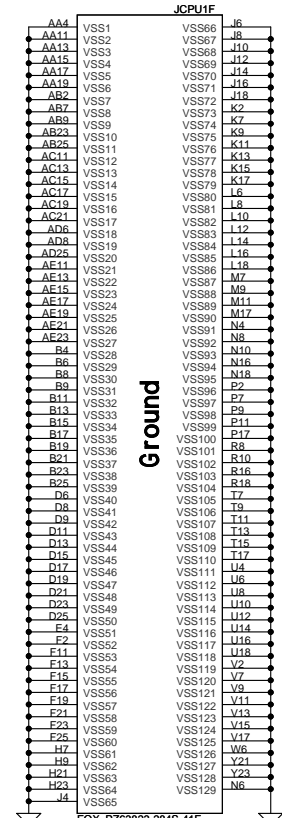
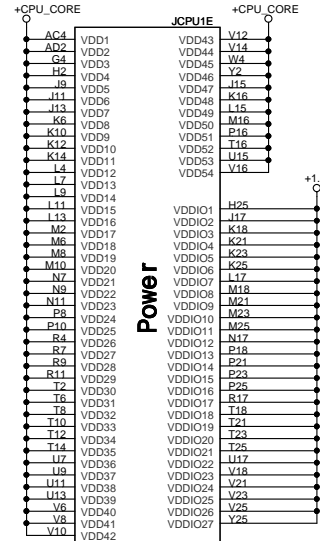
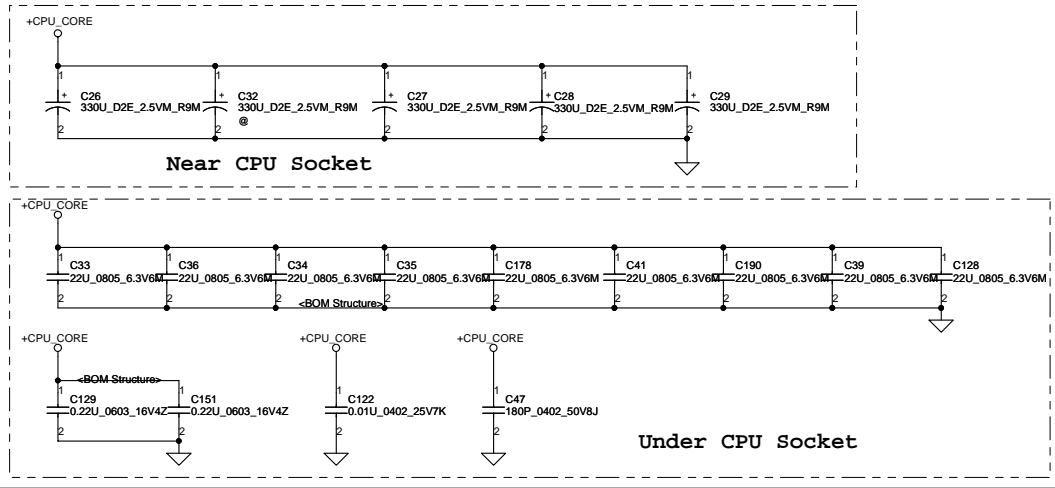

Power

Ground

FOX_PZ63823-284S-41F
CONN@
A1thon 64 S1
Processor Socket

FOX_PZ63823-284S-41F
CONN@
A1thon 64 S1
Processor Socket

VDDIO decoupling.

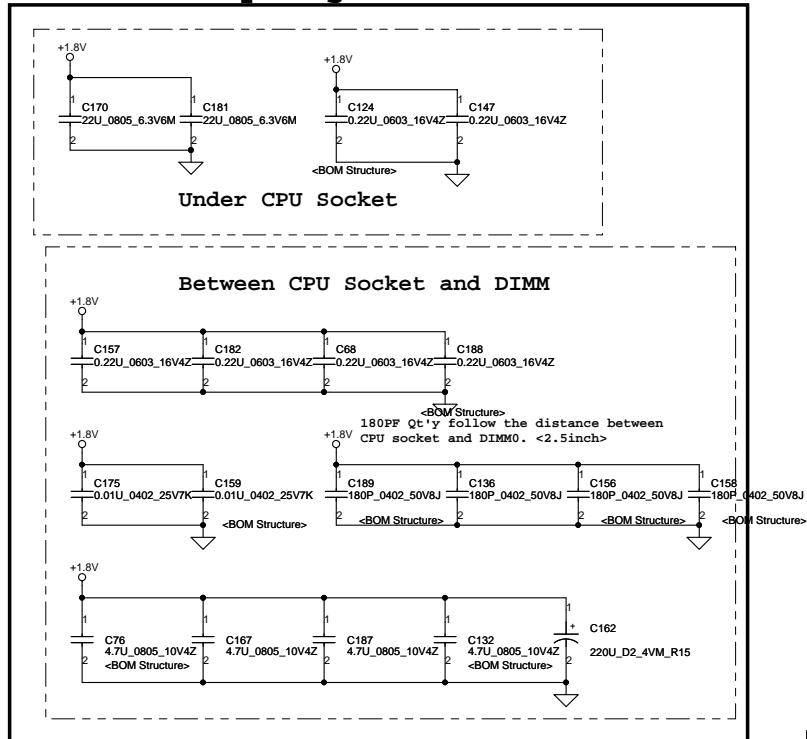

VTT decoupling.

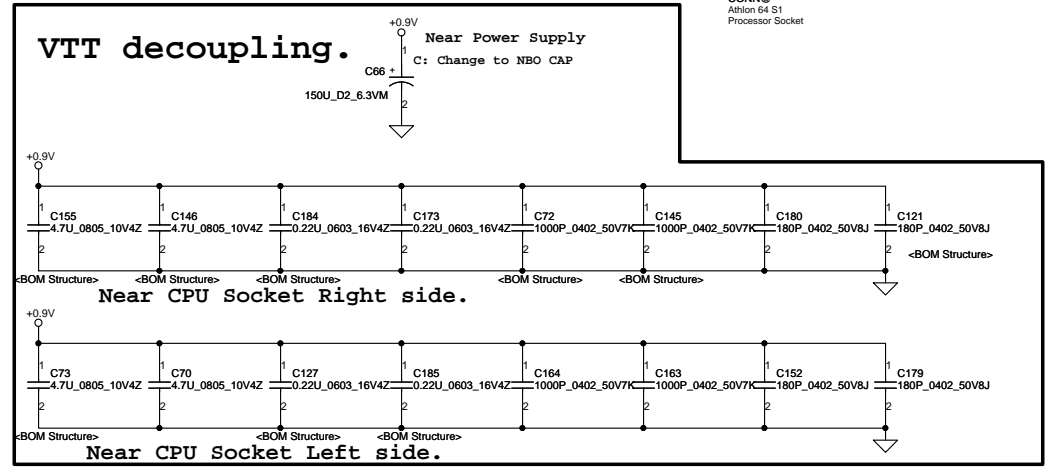

Security Classification	Compal Secret Data			Title	Compal Electronics, Inc.	
Issued Date	2007/5/18	Deciphered Date	2010/03/12	Document Number	SCHEMATIC, MB A5481	
THIS SHEET OF ENGINEERING DRAWING IS THE PROPRIETARY PROPERTY OF COMPAL ELECTRONICS, INC. AND CONTAINS CONFIDENTIAL AND TRADE SECRET INFORMATION. THIS SHEET MAY NOT BE REPRODUCED OR TRANSMITTED IN ANY FORM OR BY ANY MEANS, ELECTRONIC OR MECHANICAL, WITHOUT PERMISSION IN WRITING FROM THE COMPETENT DIVISION OF R&D DEPARTMENT EXCEPT AS AUTHORIZED BY COMPAL ELECTRONICS, INC. NEITHER THIS SHEET NOR THE INFORMATION IT CONTAINS MAY BE USED BY OR DISCLOSED TO ANY THIRD PARTY WITHOUT PRIOR WRITTEN CONSENT OF COMPAL ELECTRONICS, INC.				Date	Wednesday, June 24, 2009	Rev C
				401743	Sheet 9 of 46	

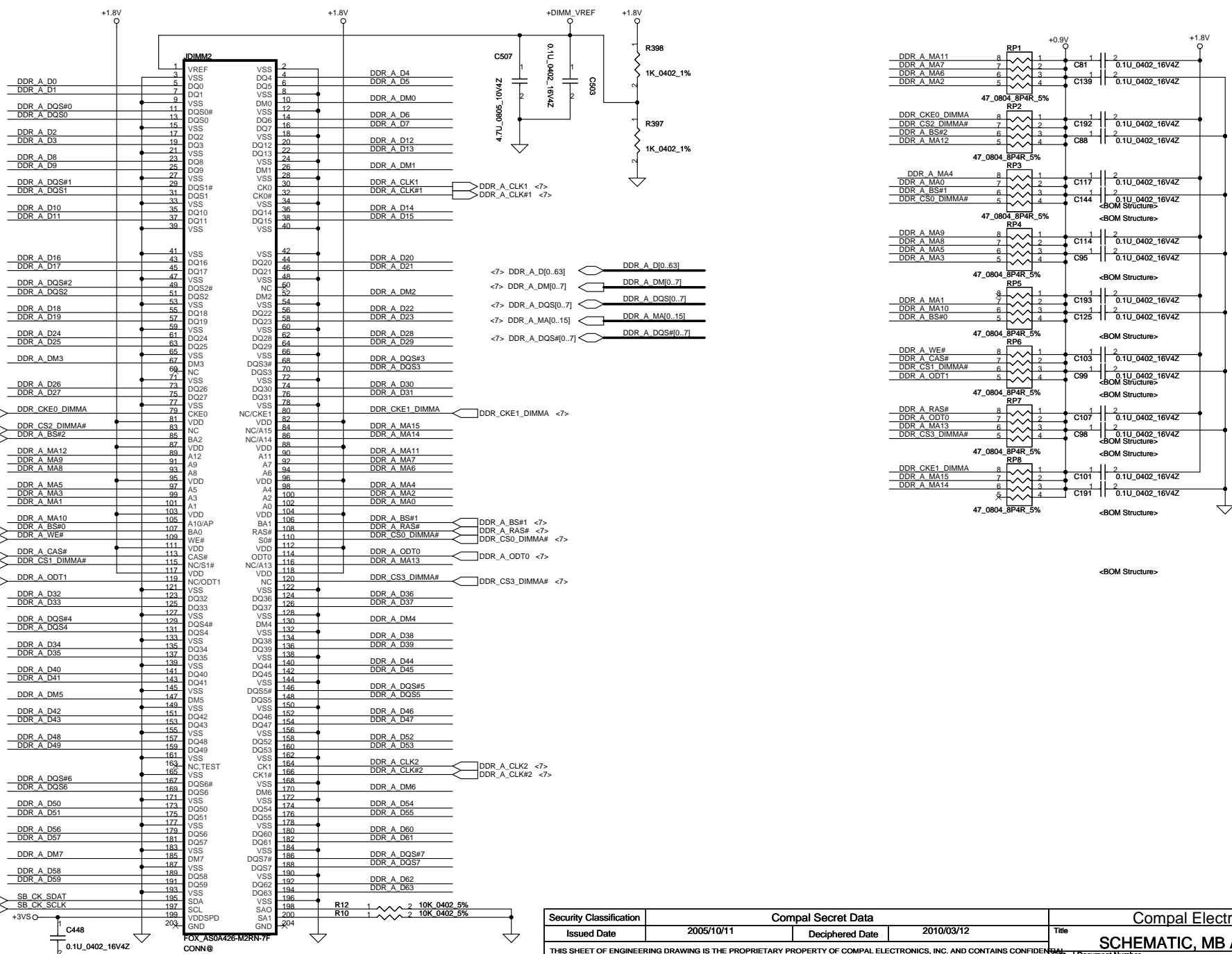

DIMM2 REV H:5.2mm (BOT)

Security Classification		Compal Secret Data		Compal Electronics, Inc.	
Issued Date	2005/10/11	Deciphered Date	2010/03/12	Title	
				SCHEMATIC, MB A5481	
<small>THIS SHEET OF ENGINEERING DRAWING IS THE PROPRIETARY PROPERTY OF COMPAL ELECTRONICS, INC. AND CONTAINS CONFIDENTIAL AND TRADE SECRET INFORMATION. THIS SHEET MAY NOT BE TRANSFERRED FROM THE CUSTODY OF THE COMPETENT DIVISION OF RAI DEPARTMENT EXCEPT AS AUTHORIZED BY COMPAL ELECTRONICS, INC. NEITHER THIS SHEET NOR THE INFORMATION IT CONTAINS MAY BE USED BY OR DISCLOSED TO ANY THIRD PARTY WITHOUT PRIOR WRITTEN CONSENT OF COMPAL ELECTRONICS, INC.</small>					
				Document Number	Rev
				401743	C
				Date: Wednesday, June 24, 2009	Sheet 10 of 46

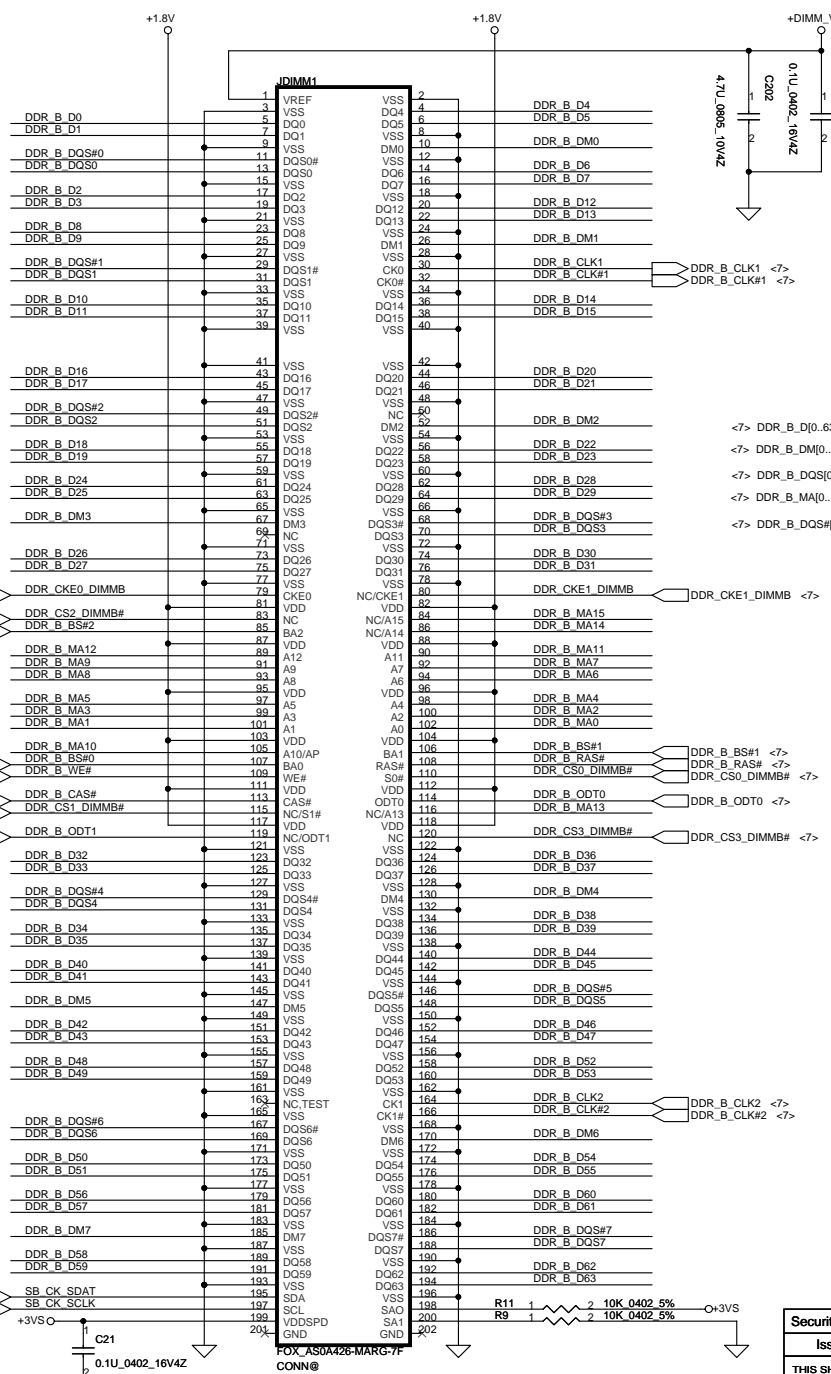

- <?> DDR_B_D[0..63] DDR_B D[0..63]
- <?> DDR_B_DM[0..7] DDR_B DM[0..7]
- <?> DDR_B_DQS[0..7] DDR_B DQS[0..7]
- <?> DDR_B_MA[0..15] DDR_B MA[0..15]
- <?> DDR_B_DQS#[0..7] DDR_B DQS#[0..7]

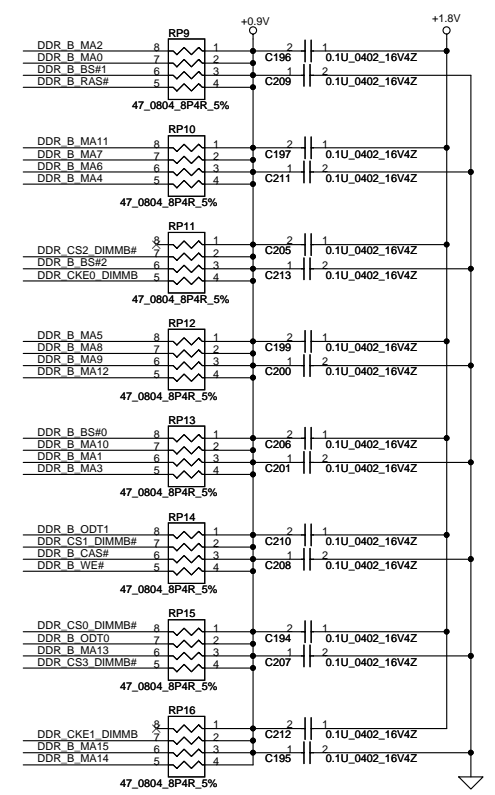

DIMM1 REV H:9.2mm (BOT)

Security Classification		Compal Secret Data	
Issued Date	2005/10/11	Deciphered Date	2010/03/12
THIS SHEET OF ENGINEERING DRAWING IS THE PROPRIETARY PROPERTY OF COMPAL ELECTRONICS, INC. AND CONTAINS CONFIDENTIAL AND TRADE SECRET INFORMATION. THIS SHEET MAY NOT BE TRANSFERRED FROM THE CUSTODY OF THE COMPETENT DIVISION OF R&D DEPARTMENT EXCEPT AS AUTHORIZED BY COMPAL ELECTRONICS, INC. NEITHER THIS SHEET NOR THE INFORMATION IT CONTAINS MAY BE USED BY OR DISCLOSED TO ANY THIRD PARTY WITHOUT PRIOR WRITTEN CONSENT OF COMPAL ELECTRONICS, INC.			

Compal Electronics, Inc.		
SCHEMATIC, MB A5481		
Rev	Document Number	Rev
	401743	
Date:	Wednesday, June 24, 2009	Sheet 11 of 46

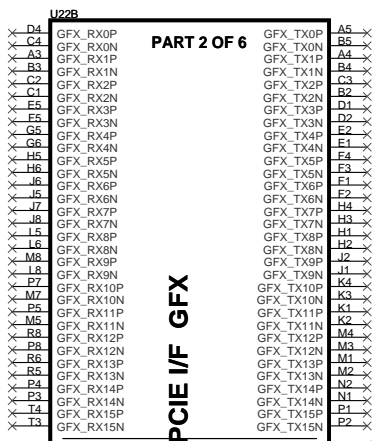

Check SW Routing
AN_RS780MN1. Only suggest pair0-3 can use for power save.

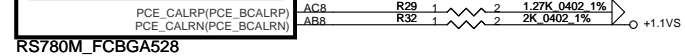
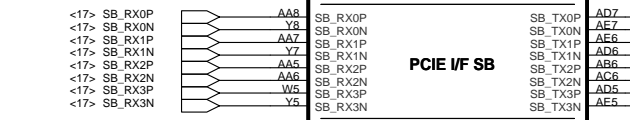
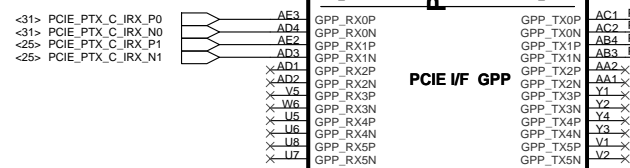

RS780M Display Port Support (muxed on GFX)

DP0	GFX_TX0, TX1, TX2 and TX3 AUX0 and HPD0
DP1	GFX_TX4, TX5, TX6 and TX7 AUX1 and HPD1

HT Link
 When tune trace length, must keep 1:4 on self-trace

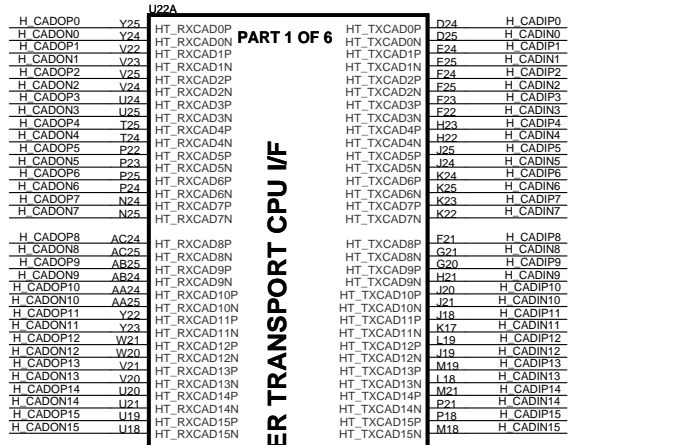
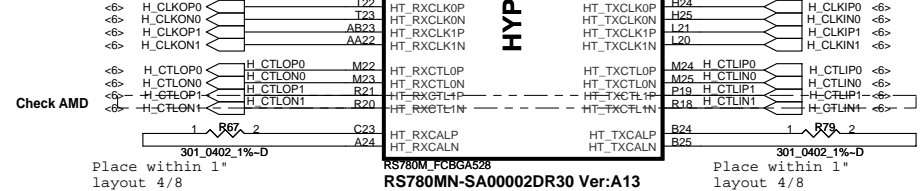

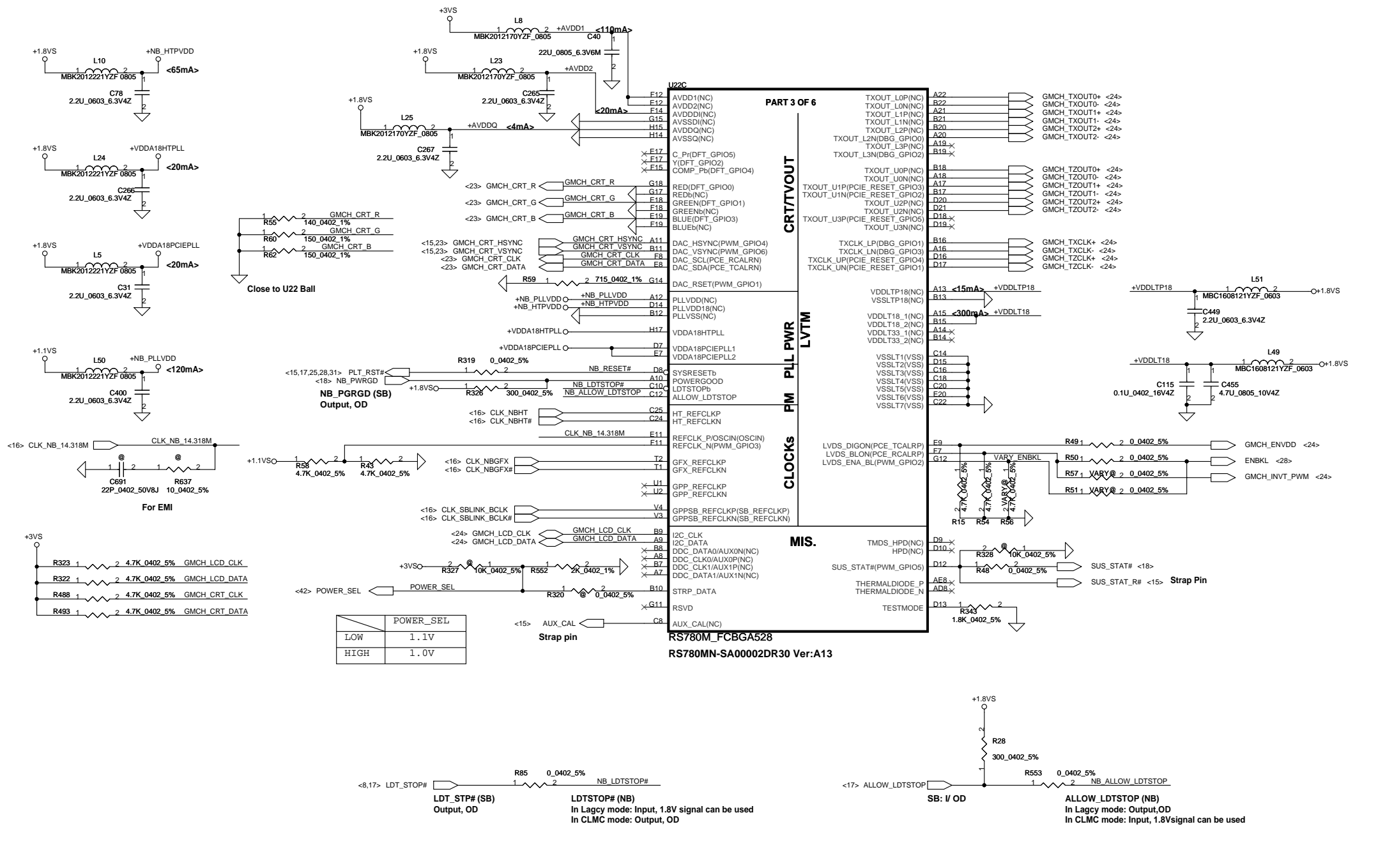

POWER_SEL	
LOW	1.1V
HIGH	1.0V

LDT_STP# (SB)
Output, OD

LDTSTOP# (NB)
In Legacy mode: Input, 1.8V signal can be used
In CLMC mode: Output, OD

SB: I/ OD

ALLOW_LDTSTOP (NB)
In Legacy mode: Output, OD
In CLMC mode: Input, 1.8V signal can be used

Security Classification		Compal Secret Data		Compal Electronics, Inc.	
Issued Date	2005/03/08	Deciphered Date	2010/03/12	Title	SCHMATIC, MB A5481
THIS SHEET OF ENGINEERING DRAWING IS THE PROPRIETARY PROPERTY OF COMPAL ELECTRONICS, INC. AND CONTAINS CONFIDENTIAL AND TRADE SECRET INFORMATION. THIS SHEET MAY NOT BE TRANSFERRED FROM THE CUSTODY OF THE COMPETENT DIVISION OF R&D DEPARTMENT EXCEPT AS AUTHORIZED BY COMPAL ELECTRONICS, INC. NEITHER THIS SHEET NOR THE INFORMATION IT CONTAINS MAY BE USED BY OR DISCLOSED TO ANY THIRD PARTY WITHOUT PRIOR WRITTEN CONSENT OF COMPAL ELECTRONICS, INC.					
Size	Document Number	Rev			
Custom	401743	C			
Date:	Wednesday, June 24, 2009	Sheet	13	of	47

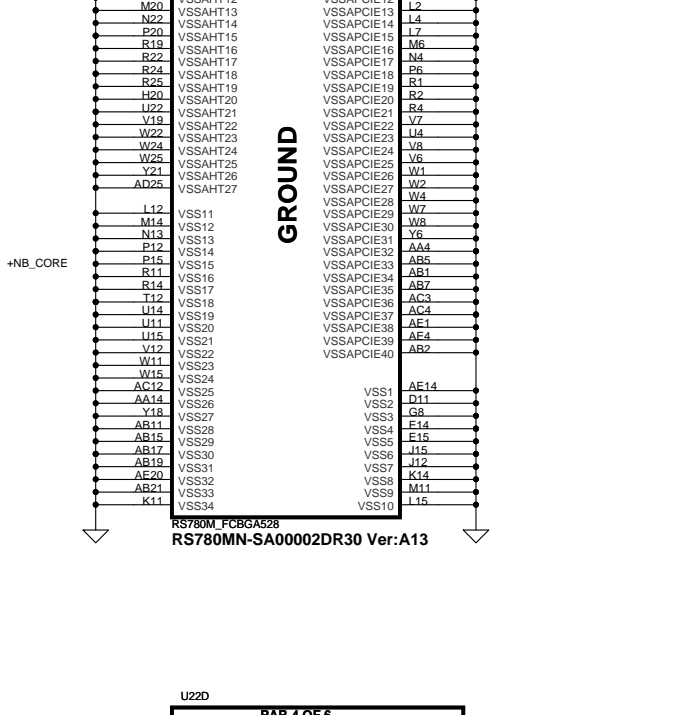
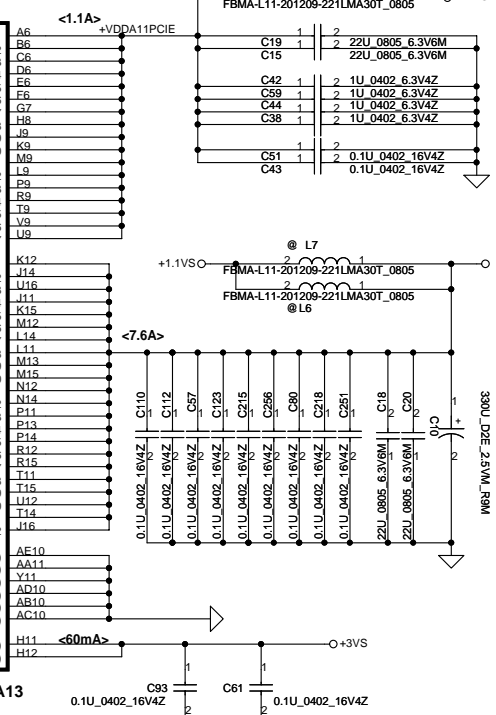
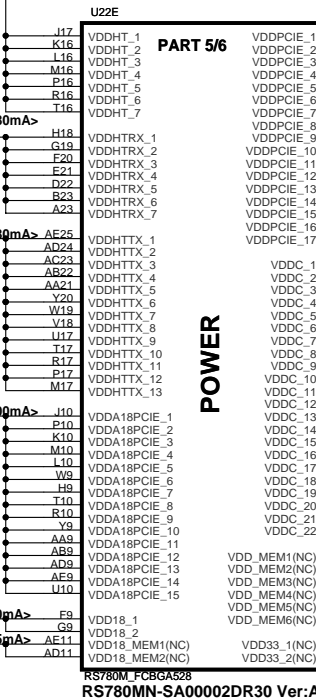
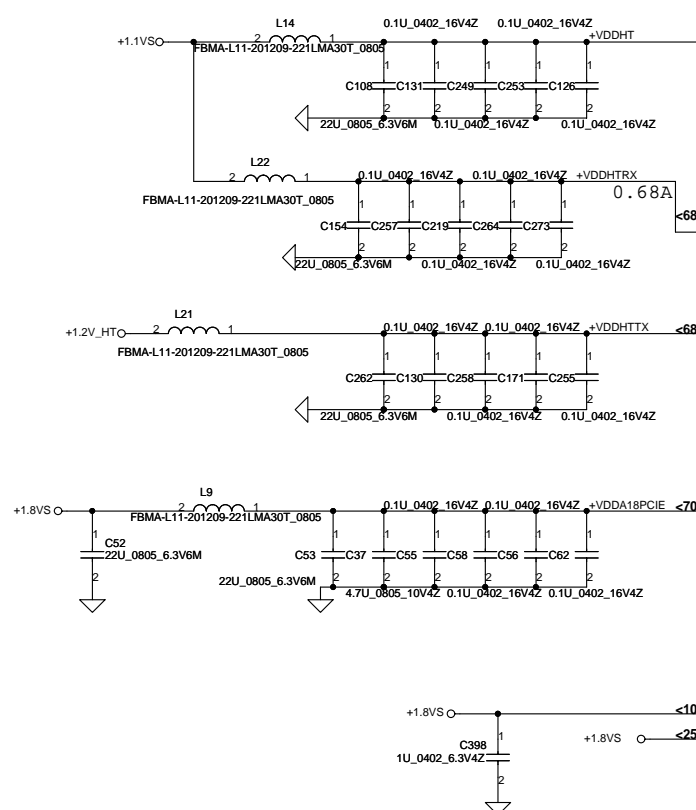

RS780M_FCBA528
RS780MN-SA00002DR30 Ver:A13

RS780M_FCBA528
RS780MN-SA00002DR30 Ver:A13

RS780M_FCBA528
RS780MN-SA00002DR30 Ver:A13

Security Classification		Compal Secret Data		Compal Electronics, Inc.	
Issued Date	2005/03/08	Deciphered Date	2010/03/12	Title	
THIS SHEET OF ENGINEERING DRAWING IS THE PROPRIETARY PROPERTY OF COMPAL ELECTRONICS, INC. AND CONTAINS CONFIDENTIAL AND TRADE SECRET INFORMATION. THIS SHEET MAY NOT BE TRANSFERRED FROM THE CUSTODY OF THE COMPETENT DIVISION OF R&D DEPARTMENT EXCEPT AS AUTHORIZED BY COMPAL ELECTRONICS, INC. NEITHER THIS SHEET NOR THE INFORMATION IT CONTAINS MAY BE USED BY OR DISCLOSED TO ANY THIRD PARTY WITHOUT PRIOR WRITTEN CONSENT OF COMPAL ELECTRONICS, INC.				Size	Document Number
				401743	Rev C
				Date: Wednesday, June 24, 2009	Sheet 14 of 47

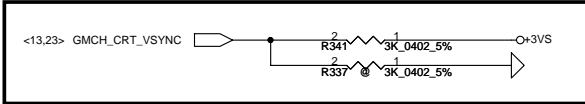

DFT_GPIO5:STRAP_DEBUG_BUS_GPIO_ENABLEb

Enables the Test Debug Bus using GPIO. (VSYNC)
 1 : Disable (RS780)
 0 : Enable (Rs780)

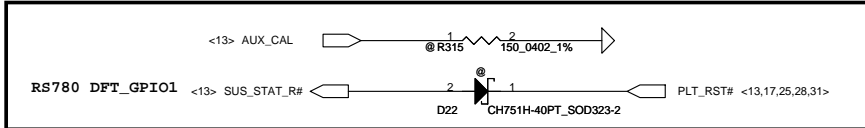

DFT_GPIO1: LOAD_EEPROM_STRAPS

Selects Loading of STRAPS from EPROM
 1 : Bypass the loading of EEPROM straps and use Hardware Default Values
 0 : I2C Master can load strap values from EEPROM if connected, or use default values if not connected
 RS740/RX780: DFT_GPIO1 RS780:SUS_STAT

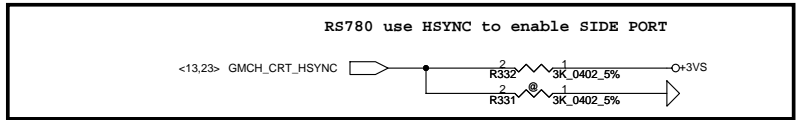

RS780 use HSYNC to enable SIDE PORT

RS740/RS780: Enables Side port memory (RS780 use HSYNC#)
 0. Enable (RS780)
 1 : Disable(RS780)

Security Classification		Compal Secret Data		Compal Electronics, Inc.	
Issued Date	2005/10/10	Deciphered Date	2010/03/12	Title	
THIS SHEET OF ENGINEERING DRAWING IS THE PROPRIETARY PROPERTY OF COMPAL ELECTRONICS, INC. AND CONTAINS CONFIDENTIAL AND TRADE SECRET INFORMATION. THIS SHEET MAY NOT BE TRANSFERRED FROM THE CUSTODY OF THE COMPETENT DIVISION OF R&D DEPARTMENT EXCEPT AS AUTHORIZED BY COMPAL ELECTRONICS, INC. NEITHER THIS SHEET NOR THE INFORMATION IT CONTAINS MAY BE USED BY OR DISCLOSED TO ANY THIRD PARTY WITHOUT PRIOR WRITTEN CONSENT OF COMPAL ELECTRONICS, INC.				Document Number	401743
				Date:	Wednesday, June 24, 2009

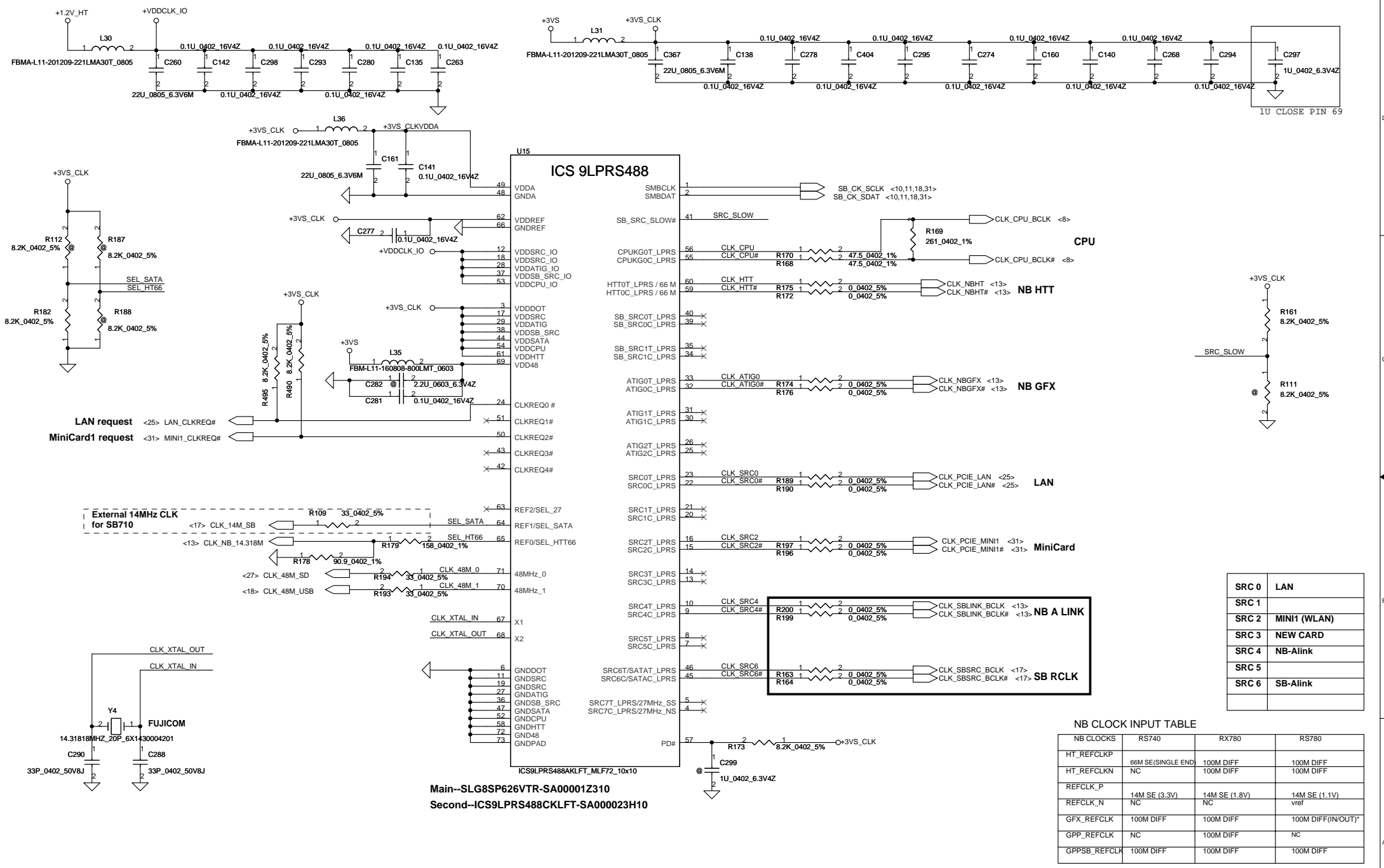

Main-SLG8SP626VTR-SA00001Z310
 Second-ICS9LPRS488CLKLFT-SA000023H10

SRC 0	LAN
SRC 1	
SRC 2	MINI1 (WLAN)
SRC 3	NEW CARD
SRC 4	NB-Alink
SRC 5	
SRC 6	SB-Alink

NB CLOCK INPUT TABLE

NB CLOCKS	RS740	RX780	RS780
HT_REFCLKP	66M SE(SINGLE END)	100M DIFF	100M DIFF
HT_REFCLKN	NC	100M DIFF	100M DIFF
REFCLK_P	NC	NC	vref
REFCLK_N	14M SE (3.3V)	14M SE (1.8V)	14M SE (1.1V)
GFX_REFCLK	100M DIFF	100M DIFF	100M DIFF(IN/OUT)*
GPP_REFCLK	NC	100M DIFF	NC
GPPSB_REFCLK	100M DIFF	100M DIFF	100M DIFF

SEL_HTT66	1	configure as single-ended 66MHz output
	0*	configure as differential 100MHz output
SEL_SATA	1*	SS 100M SATA SRC6 output
	0	SS 100M SATA SRC6 output

SEL_27M	1	configure as 27M and 27M_SS output
No used	0	configure as SRC_7 output

Security Classification	Compal Secret Data		Title	Compal Electronics, Inc.	
Issued Date	2005/03/08	Deciphered Date	2010/03/12	Size	Document Number
THIS SHEET OF ENGINEERING DRAWING IS THE PROPRIETARY PROPERTY OF COMPAL ELECTRONICS, INC. AND CONTAINS CONFIDENTIAL AND TRADE SECRET INFORMATION. THIS SHEET MAY NOT BE TRANSFERRED FROM THE CUSTODY OF THE COMPETENT DIVISION OF R&D DEPARTMENT EXCEPT AS AUTHORIZED BY COMPAL ELECTRONICS, INC. NEITHER THIS SHEET NOR THE INFORMATION IT CONTAINS MAY BE USED BY OR DISCLOSED TO ANY THIRD PARTY WITHOUT PRIOR WRITTEN CONSENT OF COMPAL ELECTRONICS, INC.					
				401743	Rev C
				Date: Wednesday, June 24, 2009	Sheet 16 of 47

SCHEMATIC, MB A5481

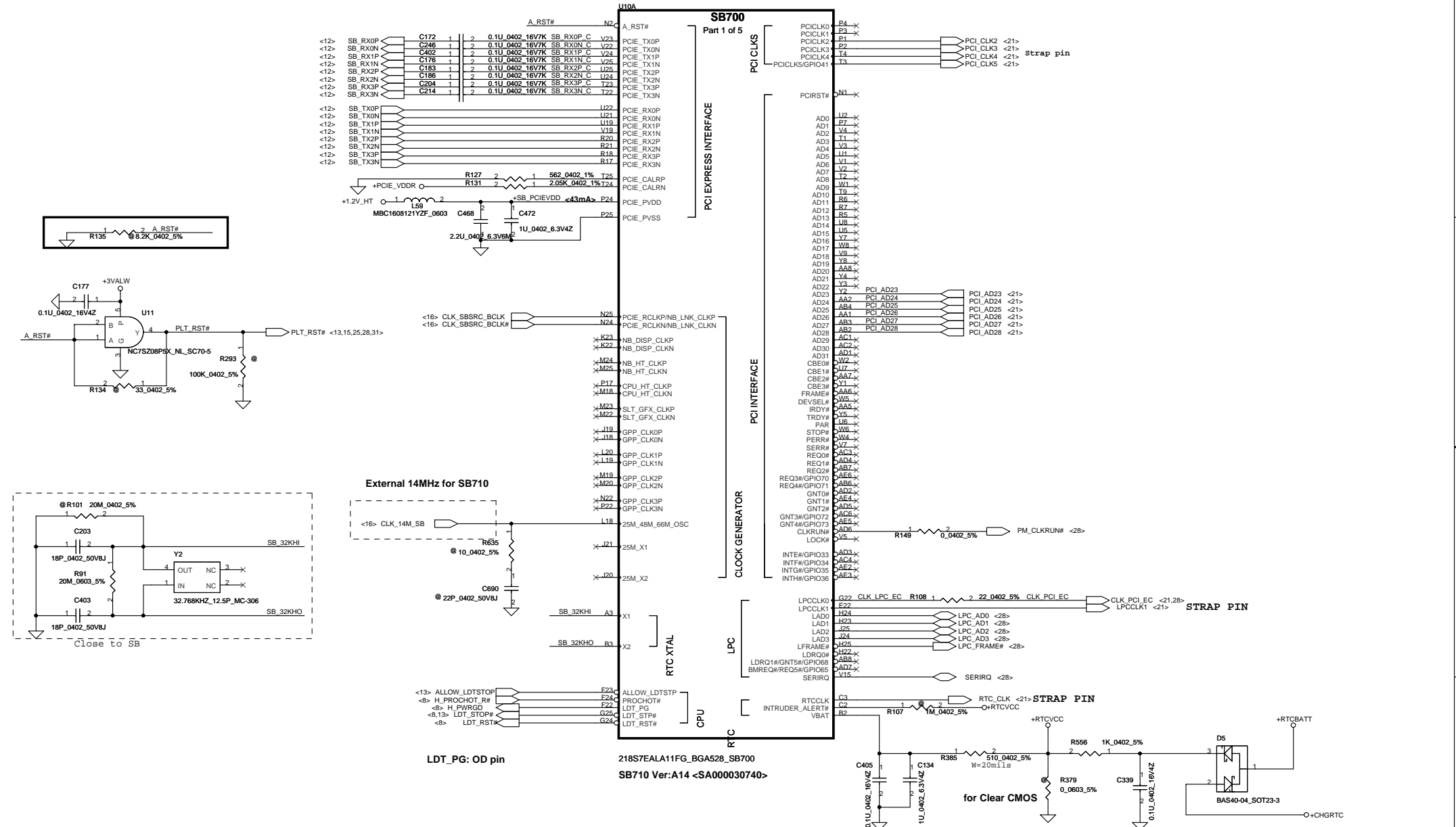

Security Classification	Compal Secret Data		Title	
Issued Date	2005/03/08	Deciphered Date	2010/03/12	Compal Electronics, Inc.
THIS SHEET OF ENGINEERING DRAWING IS THE PROPRIETARY PROPERTY OF COMPAL ELECTRONICS, INC. AND CONTAINS CONFIDENTIAL AND TRADE SECRET INFORMATION. THIS SHEET MAY NOT BE TRANSFERRED FROM THE CUSTODY OF THE COMPETENT DIVISION OF R&D DEPARTMENT EXCEPT AS AUTHORIZED BY COMPAL ELECTRONICS, INC. NEITHER THIS SHEET NOR THE INFORMATION IT CONTAINS MAY BE USED BY OR DISCLOSED TO ANY THIRD PARTY WITHOUT PRIOR WRITTEN CONSENT OF COMPAL ELECTRONICS, INC.				Document Number 401743 Date: Wednesday, June 24, 2009 Sheet 17 of 47

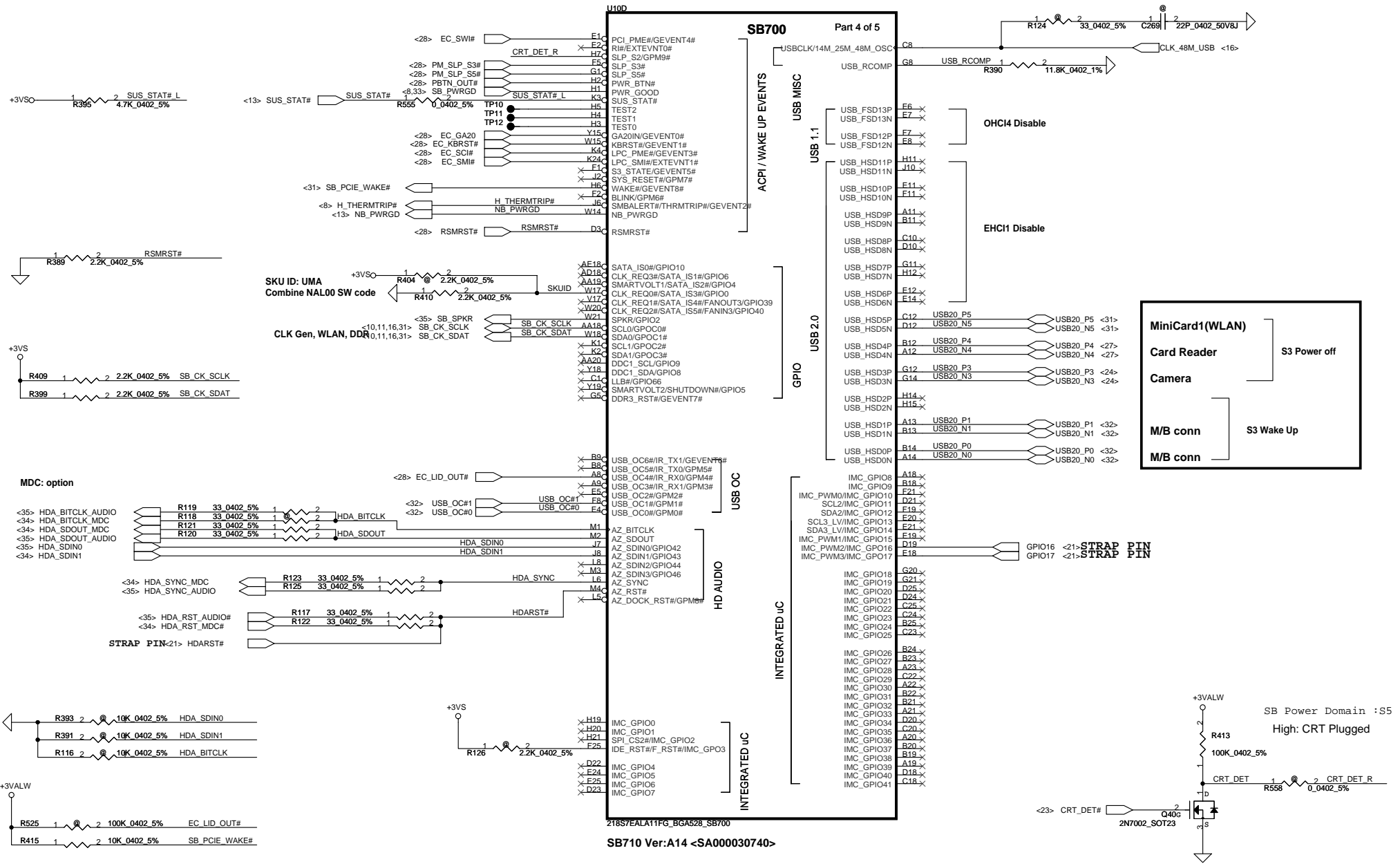

SB710 Ver:A14 <SA000030740>

Security Classification		Compal Secret Data		Compal Electronics, Inc.	
Issued Date	2005/03/08	Deciphered Date	2010/03/12	Title	
THIS SHEET OF ENGINEERING DRAWING IS THE PROPRIETARY PROPERTY OF COMPAL ELECTRONICS, INC. AND CONTAINS CONFIDENTIAL AND TRADE SECRET INFORMATION. THIS SHEET MAY NOT BE TRANSFERRED FROM THE CUSTODY OF THE COMPETENT DIVISION OF R&D DEPARTMENT EXCEPT AS AUTHORIZED BY COMPAL ELECTRONICS, INC. NEITHER THIS SHEET NOR THE INFORMATION IT CONTAINS MAY BE USED BY OR DISCLOSED TO ANY THIRD PARTY WITHOUT PRIOR WRITTEN CONSENT OF COMPAL ELECTRONICS, INC.				Size	Document Number
				Customer	401743
Date:	Wednesday, June 24, 2009	Sheet	18	of	47

Main HDD
2nd HDD
Main ODD
2nd ODD

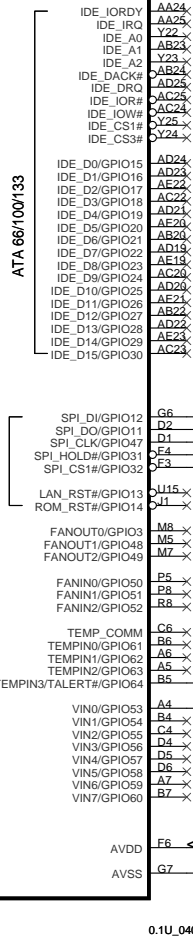
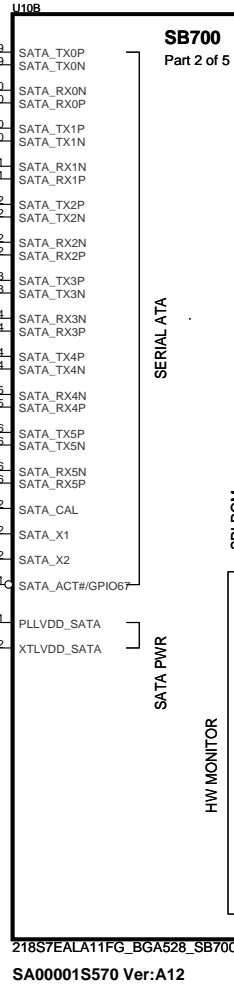
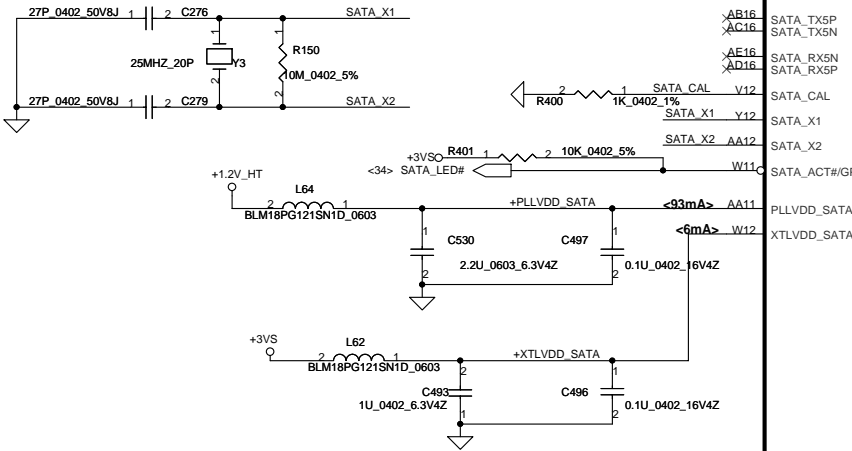
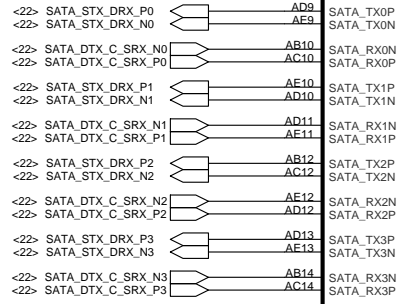

Port Number	Pri/SEC,Mas/Slave assignment	SATA drive controlled by
Port 0	Primary master	SATA controller
Port 1	Secondary master	SATA controller
Port 2	Primary slave	SATA controller
Port 3	Secondary slave	SATA controller
Port 4	Primary (Secondary) master	PATA controller
Port 5	Primary (Secondary) slave	PATA controller

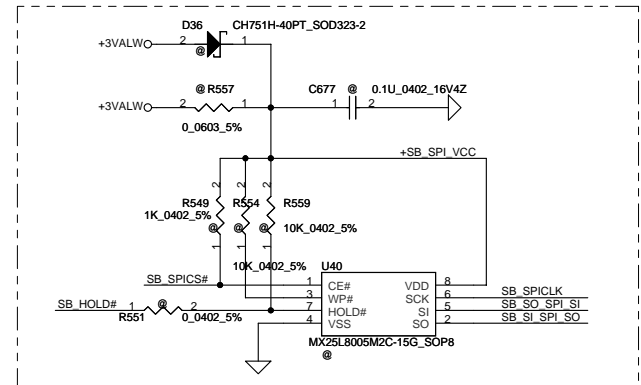

Reserve For Debug

for ACIN level issue

Security Classification	Compal Secret Data		Compal Electronics, Inc.	
Issued Date	2005/03/08	Deciphered Date	2010/03/12	Title
THIS SHEET OF ENGINEERING DRAWING IS THE PROPRIETARY PROPERTY OF COMPAL ELECTRONICS, INC. AND CONTAINS CONFIDENTIAL AND TRADE SECRET INFORMATION. THIS SHEET MAY NOT BE TRANSFERRED FROM THE CUSTODY OF THE COMPETENT DIVISION OF R&D DEPARTMENT EXCEPT AS AUTHORIZED BY COMPAL ELECTRONICS, INC. NEITHER THIS SHEET NOR THE INFORMATION IT CONTAINS MAY BE USED BY OR DISCLOSED TO ANY THIRD PARTY WITHOUT PRIOR WRITTEN CONSENT OF COMPAL ELECTRONICS, INC.				Size
				Document Number
				401743
				Rev
				C
				Date: Wednesday, June 24, 2009
				Sheet 19 of 47

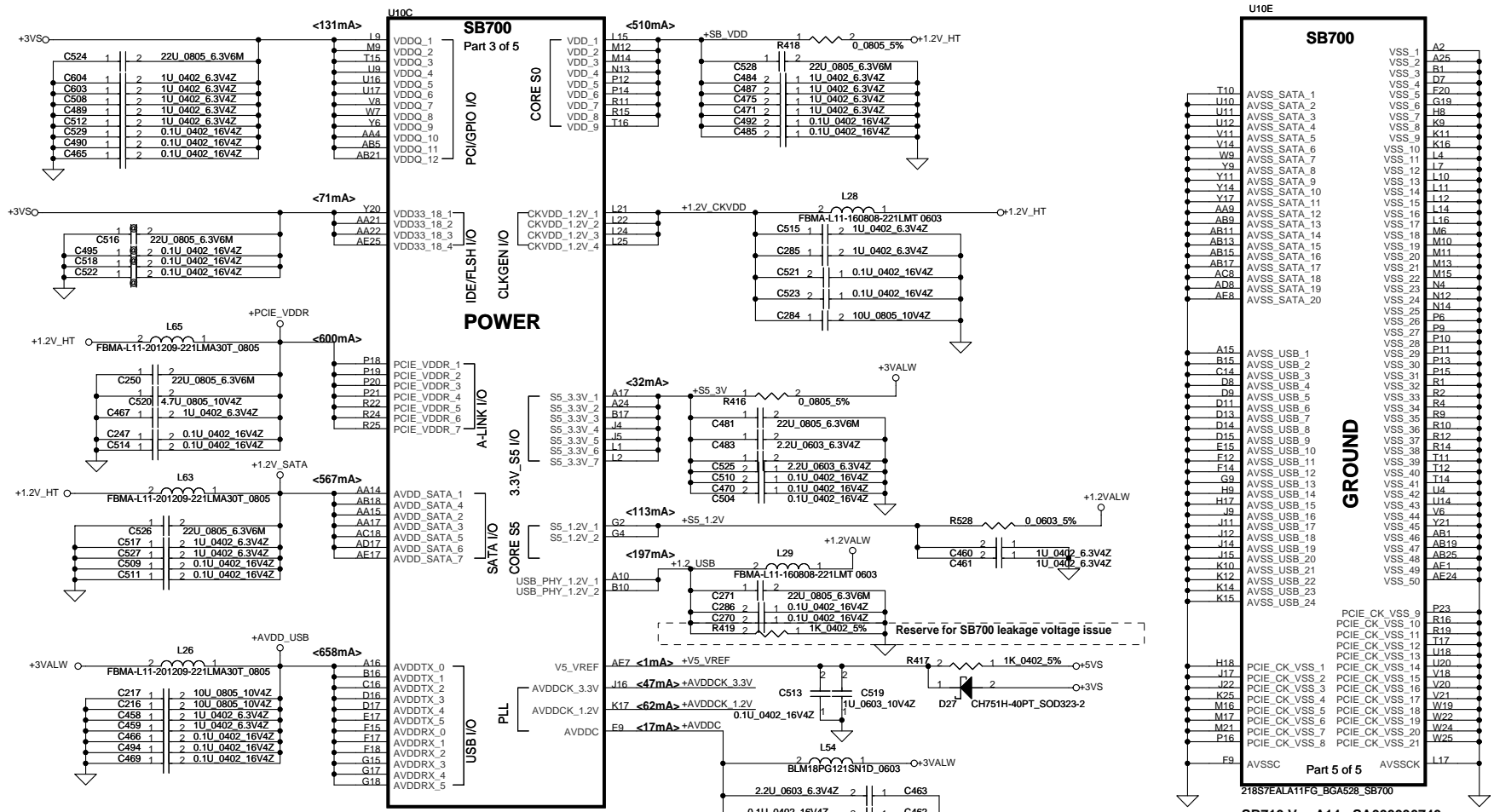

218S7EAL11FG_BGA528_SB700
 SB710 Ver:A14 <SA000030740>

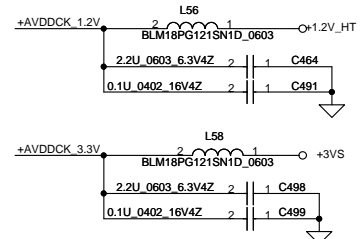

Security Classification		Compal Secret Data		Title	
Issued Date	2005/03/08	Deciphered Date	2010/03/12	SCHEMATIC, MB A5481	
THIS SHEET OF ENGINEERING DRAWING IS THE PROPRIETARY PROPERTY OF COMPAL ELECTRONICS, INC. AND CONTAINS CONFIDENTIAL AND TRADE SECRET INFORMATION. THIS SHEET MAY NOT BE TRANSFERRED FROM THE CUSTODY OF THE COMPETENT DIVISION OF R&D DEPARTMENT EXCEPT AS AUTHORIZED BY COMPAL ELECTRONICS, INC. NEITHER THIS SHEET NOR THE INFORMATION IT CONTAINS MAY BE USED BY OR DISCLOSED TO ANY THIRD PARTY WITHOUT PRIOR WRITTEN CONSENT OF COMPAL ELECTRONICS, INC.				Size	Rev
				Customer	C
				Date:	Wednesday, June 24, 2009
				Sheet	20 of 47

REQUIRED STRAPS

NOTE: SB700 HAS INTERNAL 15K PULL UP RESISTOR FOR RTC_CLK

	PCI_CLK2	PCI_CLK3	PCI_CLK4	PCI_CLK5	LPC_CLK0 CLK_PCI_EC	LPC_CLK1	RTC_CLK	AZ_RST_CD#	GP17	GP16
PULL HIGH	BOOTFAIL TIMER ENABLED	USE DEBUG STRAPS	RESERVED	RESERVED	ENABLE PCI MEM BOOT	CLKGEN ENABLED	INTERNAL RTC DEFAULT	EC ENABLED	Internal pull up H,H = Reserved H,L = SPI ROM	
PULL LOW	BOOTFAIL TIMER DISABLED DEFAULT	IGNORE DEBUG STRAPS DEFAULT			DISABLE PCI MEM BOOT DEFAULT	CLKGEN DISABLED DEFAULT	EXT. RTC (PD on X1, apply 32KHz to RTC_CLK)	EC DISABLED DEFAULT	L,H = LPC ROM (Default L,NC) L,L = FWH ROM	

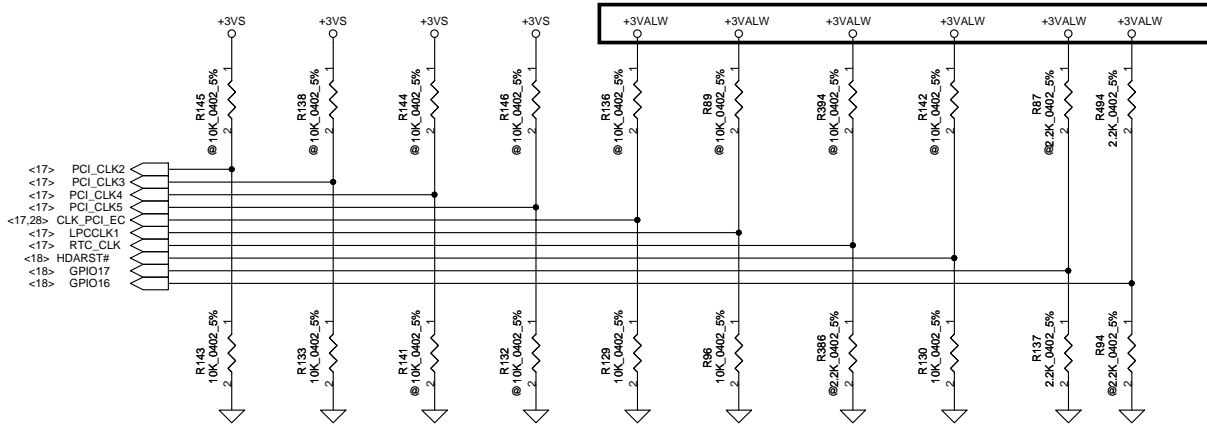

DEBUG STRAPS

DEBUG STRAPS

SB700 HAS 15K INTERNAL PU FOR PCI_AD[28:23]

	PCI_AD28	PCI_AD27	PCI_AD26	PCI_AD25	PCI_AD24	PCI_AD23
PULL HIGH	USE LONG RESET DEFAULT	USE PCI PLL DEFAULT	USE ACPI BCLK DEFAULT	USE IDE PLL DEFAULT	USE DEFAULT PCIE STRAPS DEFAULT	RESERVED
PULL LOW	USE SHORT RESET	BYPASS PCI PLL	BYPASS ACPI BCLK	BYPASS IDE PLL	USE EEPROM PCIE STRAPS	

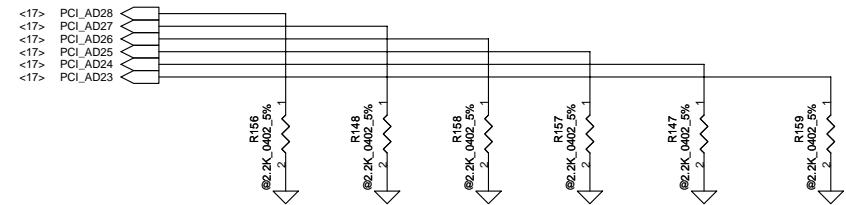

Security Classification		Compal Secret Data		Compal Electronics, Inc.	
Issued Date	2005/03/08	Deciphered Date	2010/03/12	Title	
THIS SHEET OF ENGINEERING DRAWING IS THE PROPRIETARY PROPERTY OF COMPAL ELECTRONICS, INC. AND CONTAINS CONFIDENTIAL AND TRADE SECRET INFORMATION. THIS SHEET MAY NOT BE TRANSFERRED FROM THE CUSTODY OF THE COMPETENT DIVISION OF R&D DEPARTMENT EXCEPT AS AUTHORIZED BY COMPAL ELECTRONICS, INC. NEITHER THIS SHEET NOR THE INFORMATION IT CONTAINS MAY BE USED BY OR DISCLOSED TO ANY THIRD PARTY WITHOUT PRIOR WRITTEN CONSENT OF COMPAL ELECTRONICS, INC.				Size Custom	Document Number 401743
				Date:	Wednesday, June 24, 2009
				Sheet	21 of 47
				Rev	C

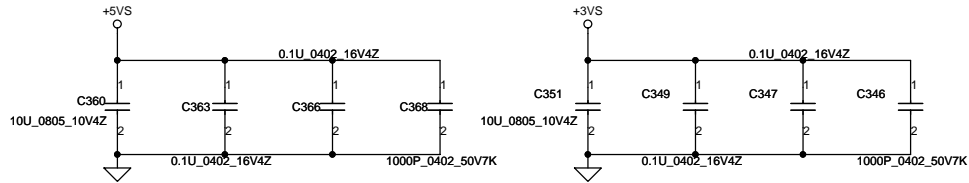

SATA HDD CONN

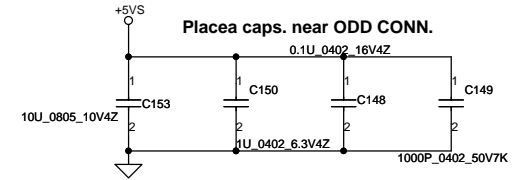

SATA ODD CONN

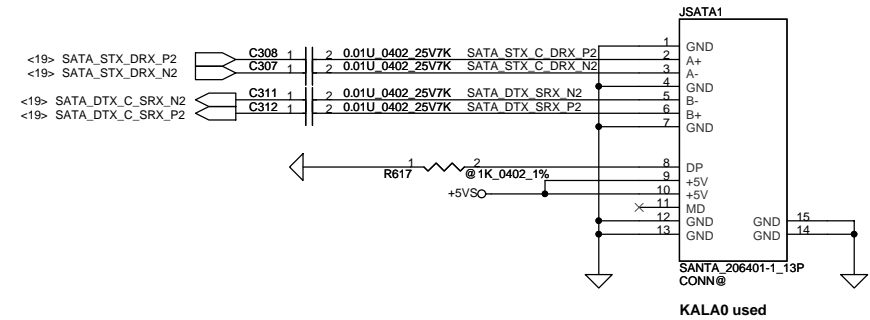
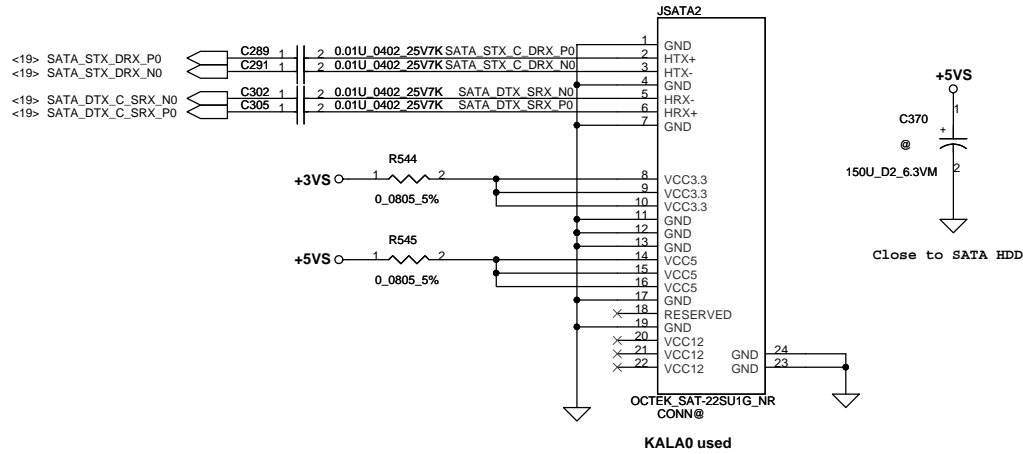

Second HDD

Second ODD

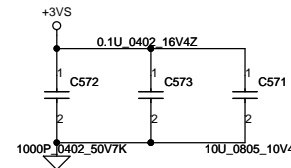
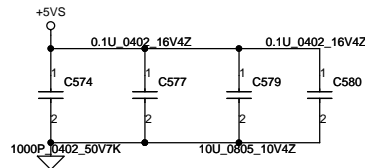
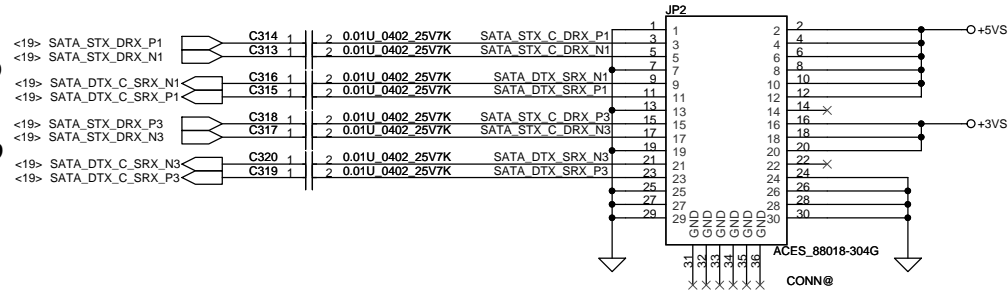

Security Classification		Compal Secret Data		Compal Electronics, Inc.	
Issued Date	2005/03/08	Deciphered Date	2010/03/12	Title	SCHEMATIC, MB A5481
THIS SHEET OF ENGINEERING DRAWING IS THE PROPRIETARY PROPERTY OF COMPAL ELECTRONICS, INC. AND CONTAINS CONFIDENTIAL AND TRADE SECRET INFORMATION. THIS SHEET MAY NOT BE TRANSFERRED FROM THE CUSTODY OF THE COMPETENT DIVISION OF R&D DEPARTMENT EXCEPT AS AUTHORIZED BY COMPAL ELECTRONICS, INC. NEITHER THIS SHEET NOR THE INFORMATION IT CONTAINS MAY BE USED BY OR DISCLOSED TO ANY THIRD PARTY WITHOUT PRIOR WRITTEN CONSENT OF COMPAL ELECTRONICS, INC.				Size	Document Number
				401743	Rev C
				Date:	Wednesday, June 24, 2009
				Sheet	22 of 47

CRT Connector

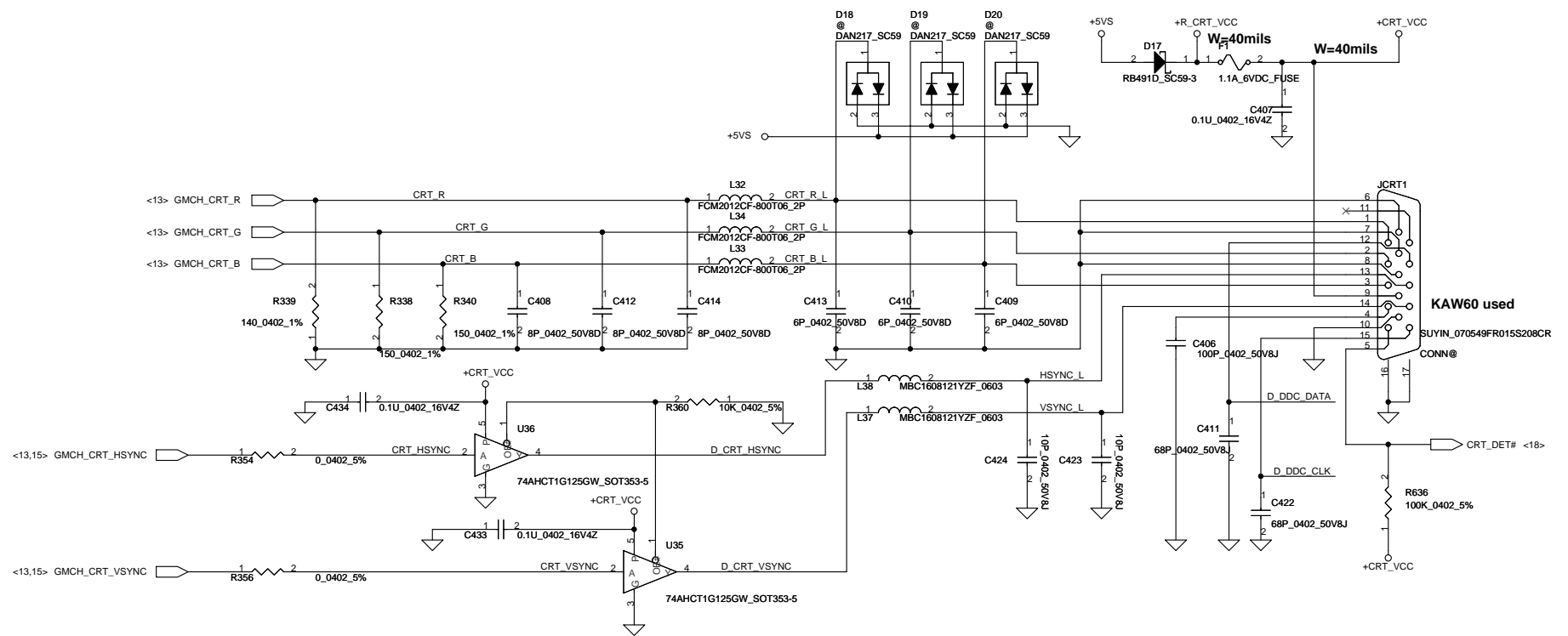

Close to Conn side

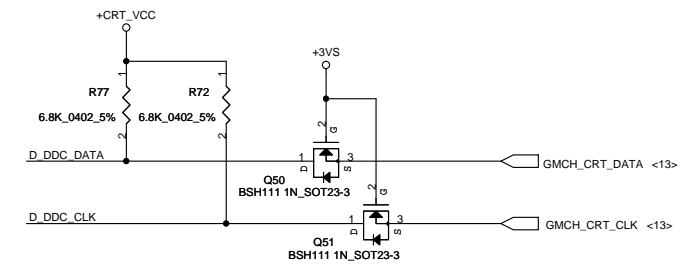

Security Classification	Compal Secret Data		Title	
Issued Date	2005/03/08	Deciphered Date	2010/03/12	Compal Electronics, Inc.
THIS SHEET OF ENGINEERING DRAWING IS THE PROPRIETARY PROPERTY OF COMPAL ELECTRONICS, INC. AND CONTAINS CONFIDENTIAL AND TRADE SECRET INFORMATION. THIS SHEET MAY NOT BE TRANSFERRED FROM THE CUSTODY OF THE COMPETENT DIVISION OF R&D DEPARTMENT EXCEPT AS AUTHORIZED BY COMPAL ELECTRONICS, INC. NEITHER THIS SHEET NOR THE INFORMATION IT CONTAINS MAY BE USED BY OR DISCLOSED TO ANY THIRD PARTY WITHOUT PRIOR WRITTEN CONSENT OF COMPAL ELECTRONICS, INC.				SCHEMATIC, MB A5481 Document Number 401743 Date: Wednesday, June 24, 2009
				Rev C Sheet 23 of 47

LCD POWER CIRCUIT

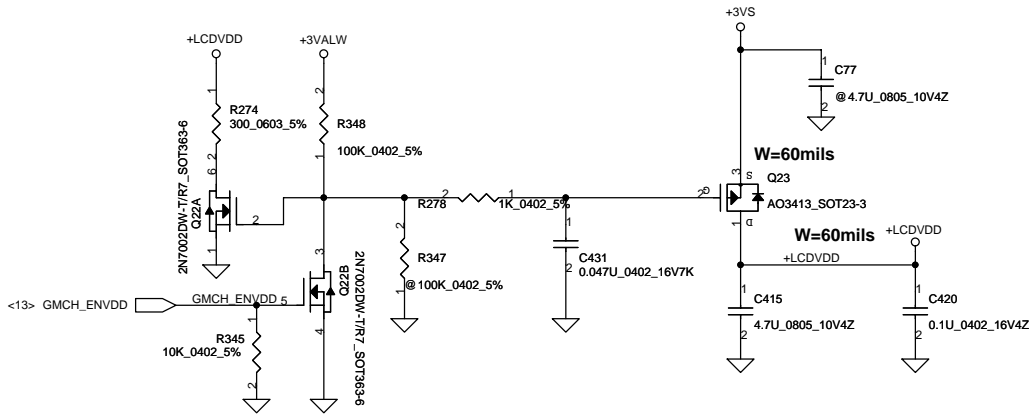

LCD/PANEL CONN.

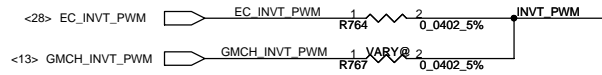
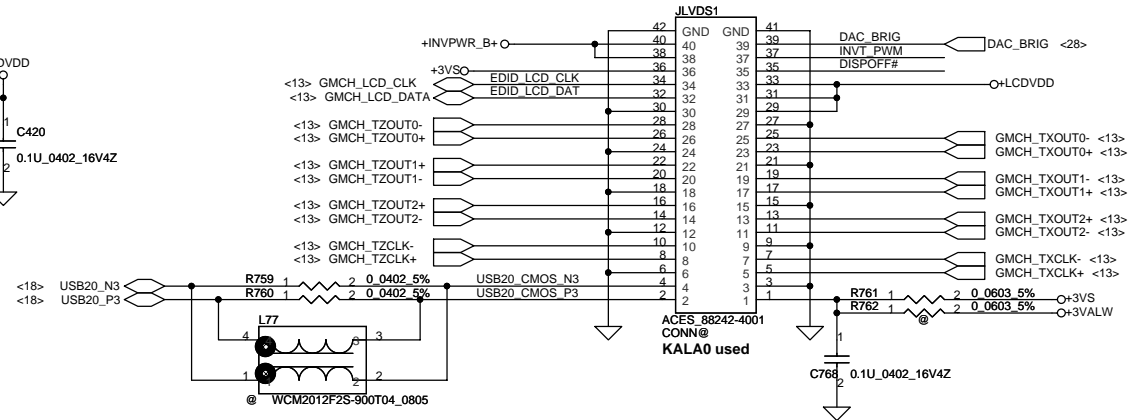

VARYBRIGHT FUNCTION

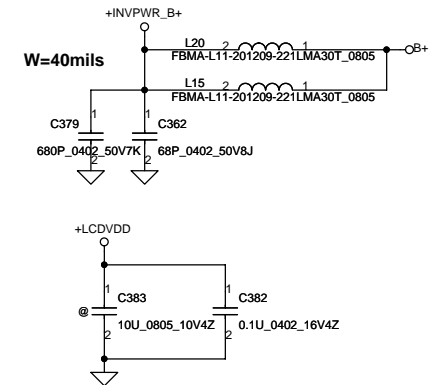
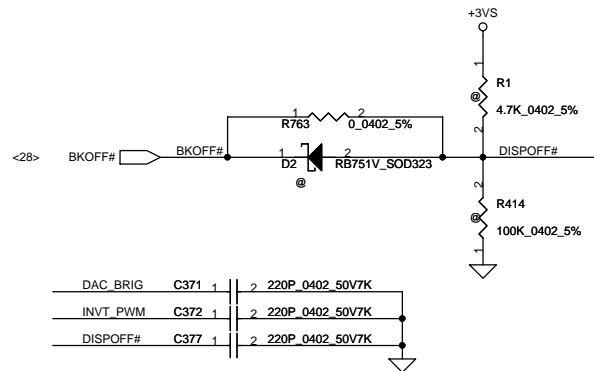
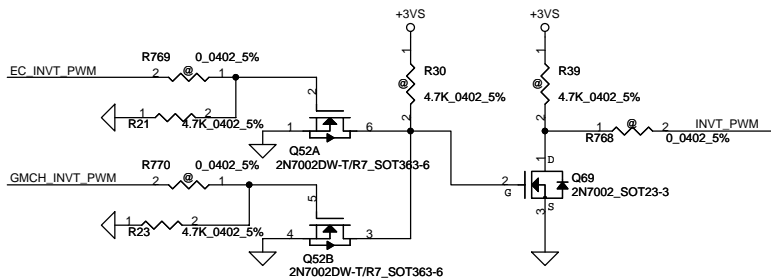

Security Classification		Compal Secret Data		Title	
Issued Date	2005/03/08	Deciphered Date	2010/03/12	Compal Electronics, Inc.	
THIS SHEET OF ENGINEERING DRAWING IS THE PROPRIETARY PROPERTY OF COMPAL ELECTRONICS, INC. AND CONTAINS CONFIDENTIAL AND TRADE SECRET INFORMATION. THIS SHEET MAY NOT BE TRANSFERRED FROM THE CUSTODY OF THE COMPETENT DIVISION OF R&D DEPARTMENT EXCEPT AS AUTHORIZED BY COMPAL ELECTRONICS, INC. NEITHER THIS SHEET NOR THE INFORMATION IT CONTAINS MAY BE USED BY OR DISCLOSED TO ANY THIRD PARTY WITHOUT PRIOR WRITTEN CONSENT OF COMPAL ELECTRONICS, INC.				Size	Rev
				Document Number	C
				401743	
				Date: Wednesday, June 24, 2009	Sheet 24 of 47

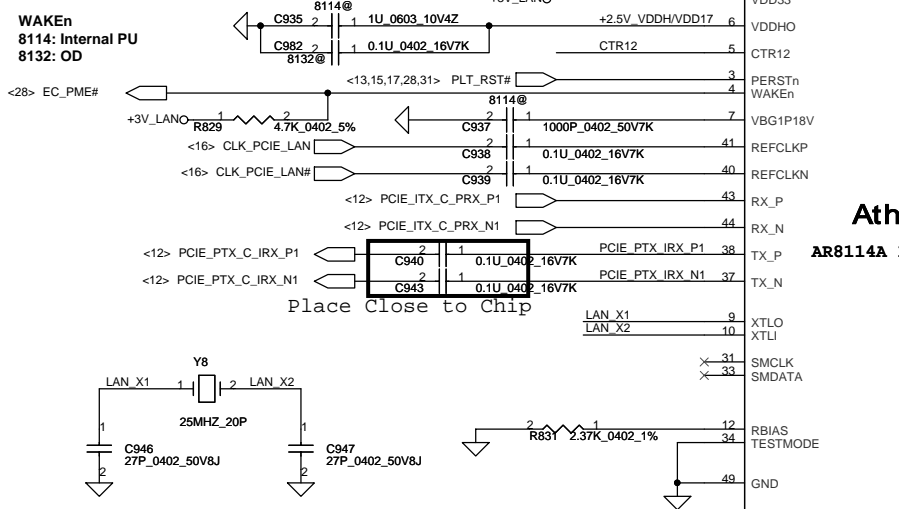
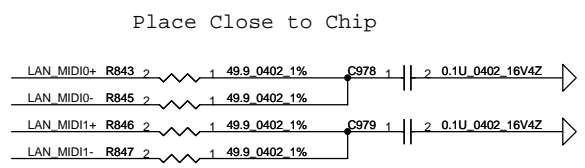
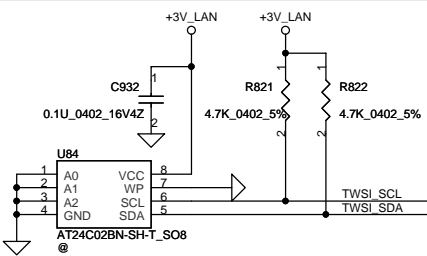
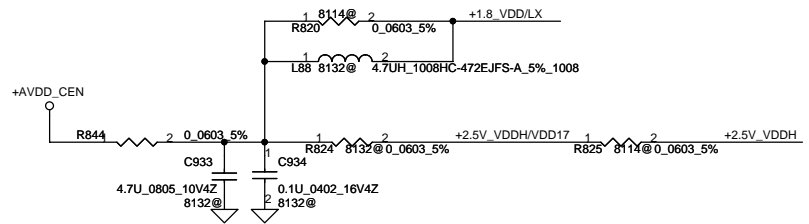

Atheros
AR8114A 10/100 LAN

change to AR8132L-AL1E

Place Close to Chip

Layout Notice : Close to chip

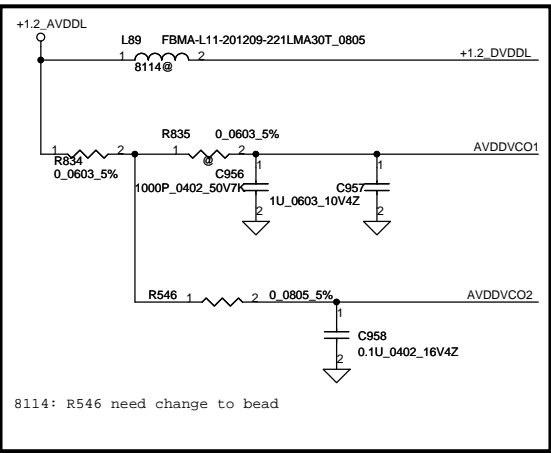
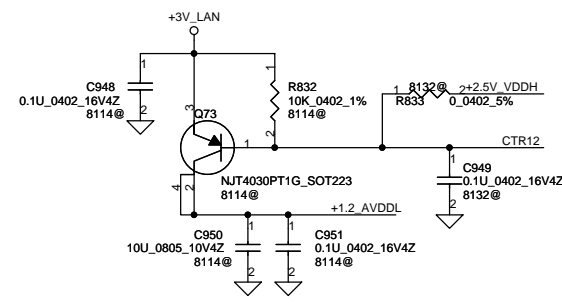
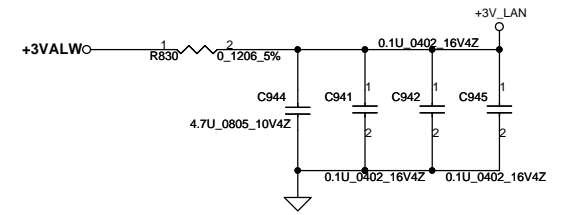

8114: R546 need change to bead

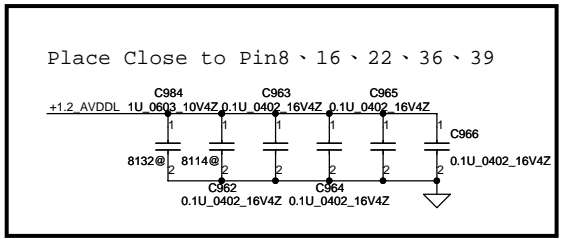
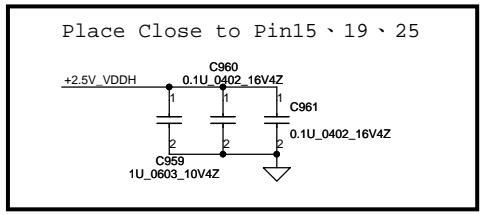
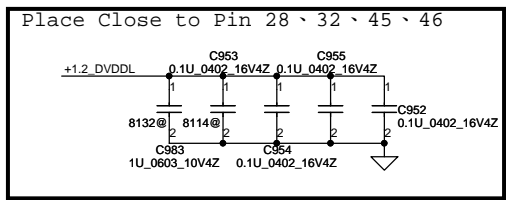

Security Classification		Compal Secret Data		Compal Electronics, Inc.	
Issued Date	2005/07/29	Deciphered Date	2010/03/12	Title	SCHMATIC, MB A5481
THIS SHEET OF ENGINEERING DRAWING IS THE PROPRIETARY PROPERTY OF COMPAL ELECTRONICS, INC. AND CONTAINS CONFIDENTIAL AND TRADE SECRET INFORMATION. THIS SHEET MAY NOT BE TRANSFERRED FROM THE CUSTODY OF THE COMPETENT DIVISION OF R&D DEPARTMENT EXCEPT AS AUTHORIZED BY COMPAL ELECTRONICS, INC. NEITHER THIS SHEET NOR THE INFORMATION IT CONTAINS MAY BE USED BY OR AS AUTHORIZED TO ANY THIRD PARTY WITHOUT PRIOR WRITTEN CONSENT OF COMPAL ELECTRONICS, INC.					
Size	B	Document Number	401743	Rev	C
Date:	Wednesday, June 24, 2009	Sheet	25	of	47

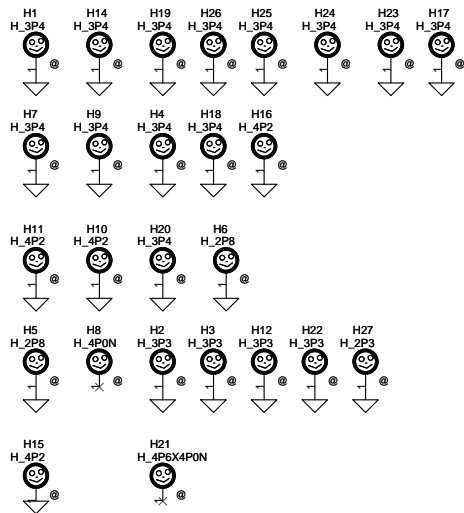
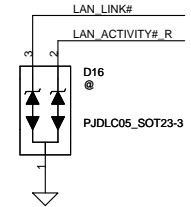
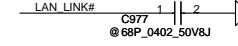
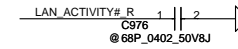
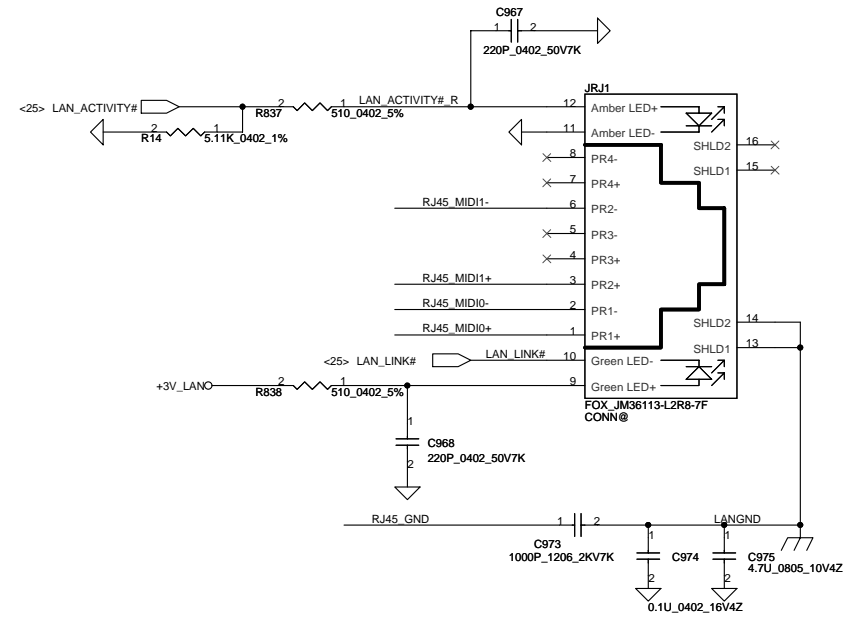
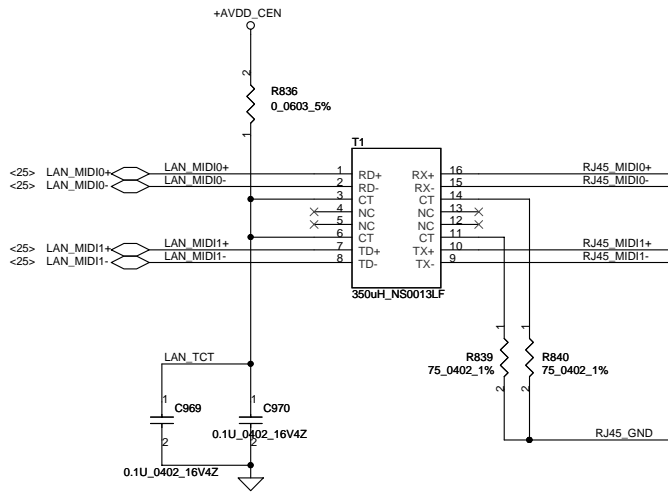

Security Classification		Compal Secret Data		Compal Electronics, Inc.	
Issued Date	2005/03/08	Deciphered Date	2010/03/12	Title	SCHEMATIC, MB A5481
THIS SHEET OF ENGINEERING DRAWING IS THE PROPRIETARY PROPERTY OF COMPAL ELECTRONICS, INC. AND CONTAINS CONFIDENTIAL AND TRADE SECRET INFORMATION. THIS SHEET MAY NOT BE TRANSFERRED FROM THE CUSTODY OF THE COMPETENT DIVISION OF R&D DEPARTMENT EXCEPT AS AUTHORIZED BY COMPAL ELECTRONICS, INC. NEITHER THIS SHEET NOR THE INFORMATION IT CONTAINS MAY BE USED BY OR DISCLOSED TO ANY THIRD PARTY WITHOUT PRIOR WRITTEN CONSENT OF COMPAL ELECTRONICS, INC.				Size	Document Number
				Custom	401743
				Date:	Wednesday, June 24, 2009
				Sheet	26 of 47
				Rev	C

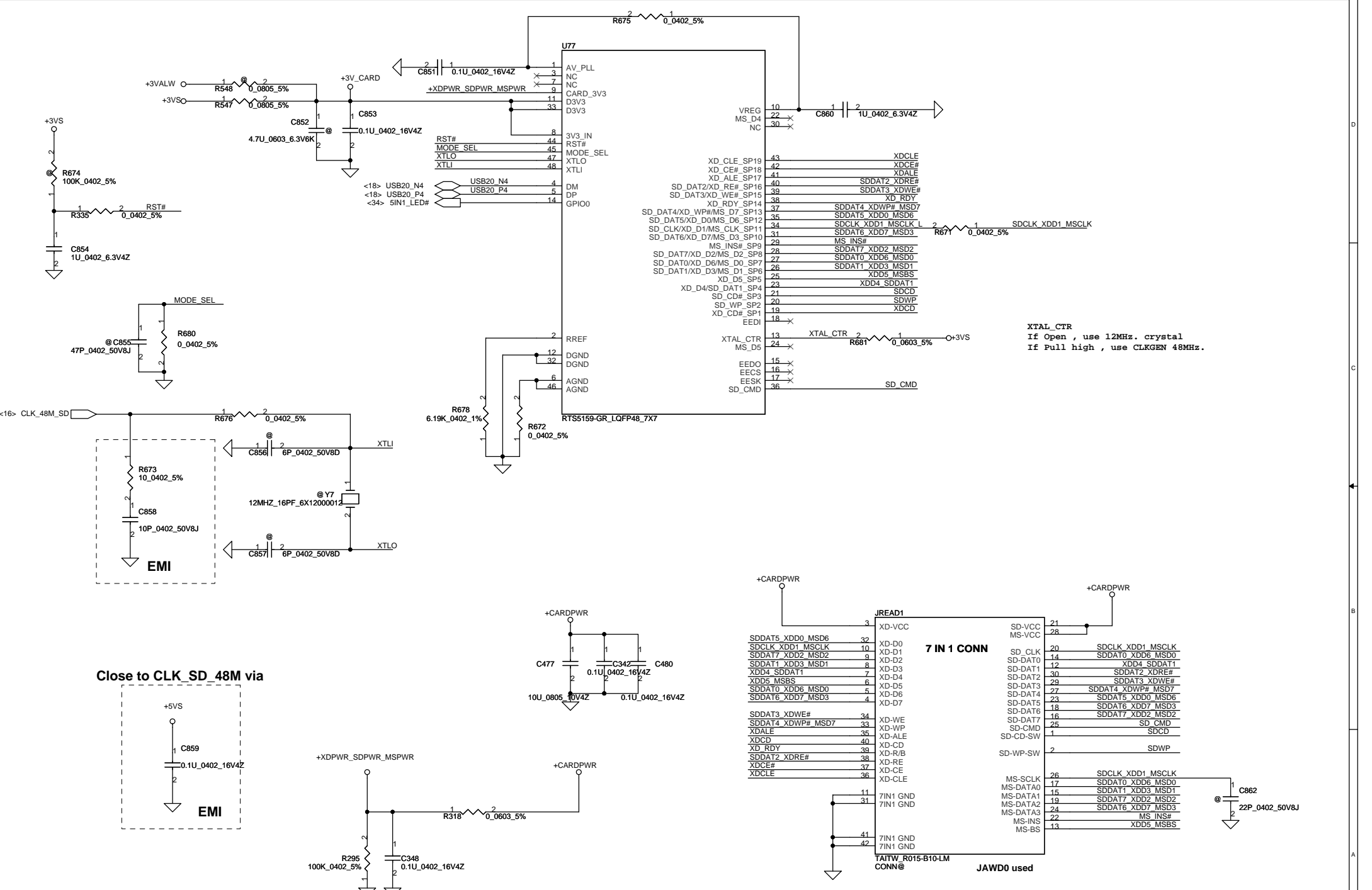

XTAL_CTR
 If Open , use 12MHz. crystal
 If Pull high , use CLKNG 48MHz.

Close to CLK_SD 48M via

Security Classification		Compal Secret Data		Title	
Issued Date		Deciphered Date		SCHEMATIC, MB A5481	
2005/07/29		2010/03/12		401743	
THIS SHEET OF ENGINEERING DRAWING IS THE PROPRIETARY PROPERTY OF COMPAL ELECTRONICS, INC. AND CONTAINS CONFIDENTIAL AND TRADE SECRET INFORMATION. THIS SHEET MAY NOT BE TRANSFERRED FROM THE CUSTODY OF THE COMPETENT DIVISION OF R&D DEPARTMENT EXCEPT AS AUTHORIZED BY COMPAL ELECTRONICS, INC. NEITHER THIS SHEET NOR THE INFORMATION IT CONTAINS MAY BE USED BY OR DISCLOSED TO ANY THIRD PARTY WITHOUT PRIOR WRITTEN CONSENT OF COMPAL ELECTRONICS, INC.					
Date: Wednesday, June 24, 2009				Sheet 27 of 47	

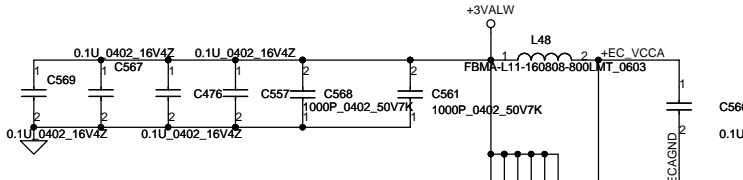
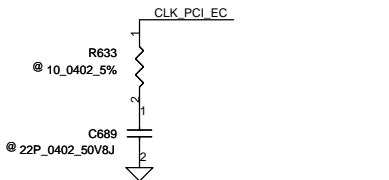

Please close to EC pin

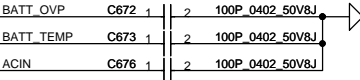

For EC Tools

Place on MiniCard

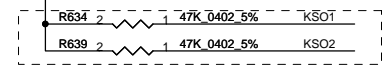
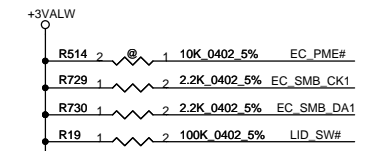
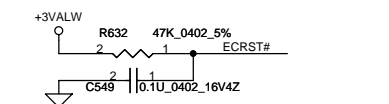
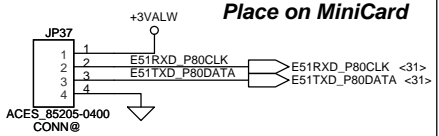

EC test-mode issue

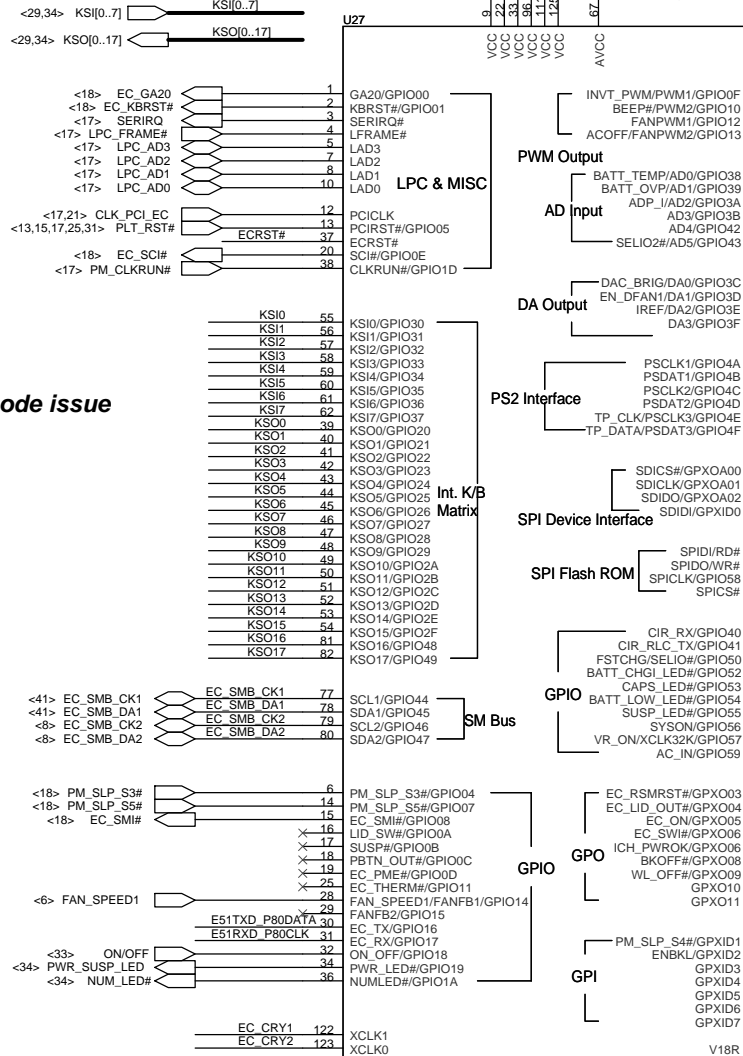
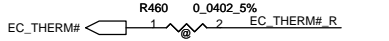
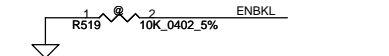
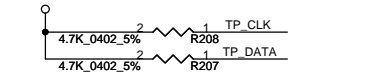
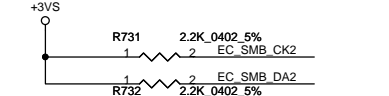

Chagne to D3 version

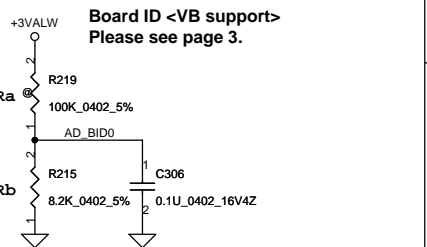
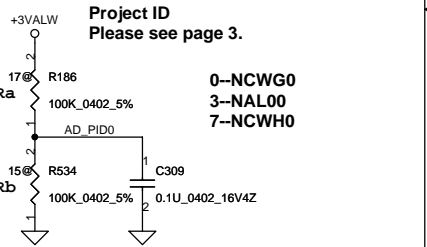
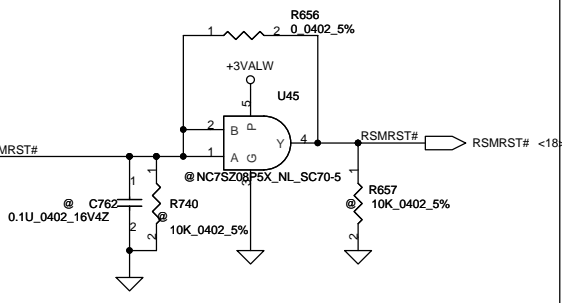
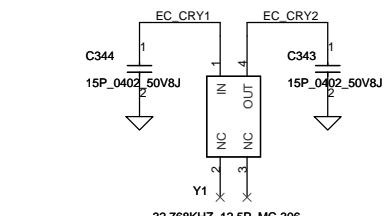

Security Classification		Compal Secret Data		Compal Electronics, Inc.	
Issued Date	2007/5/18	Deciphered Date	2010/03/12	Title	
THIS SHEET OF ENGINEERING DRAWING IS THE PROPRIETARY PROPERTY OF COMPAL ELECTRONICS, INC. AND CONTAINS CONFIDENTIAL AND TRADE SECRET INFORMATION. THIS SHEET MAY NOT BE TRANSFERRED FROM THE CUSTODY OF THE COMPETENT DIVISION OF R&D DEPARTMENT EXCEPT AS AUTHORIZED BY COMPAL ELECTRONICS, INC. NEITHER THIS SHEET NOR THE INFORMATION IT CONTAINS MAY BE USED BY OR DISCLOSED TO ANY THIRD PARTY WITHOUT PRIOR WRITTEN CONSENT OF COMPAL ELECTRONICS, INC.				Document Number	Rev
				401743	C
Date: Wednesday, June 24, 2009				Sheet 28	of 47

For 17"

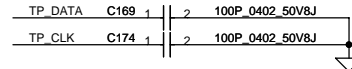
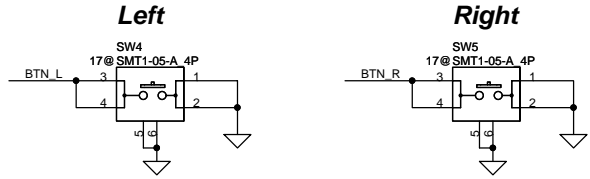

To TP/B Conn.

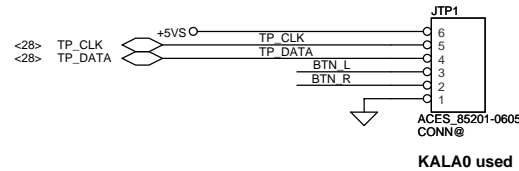

KALA0 used

For 15"

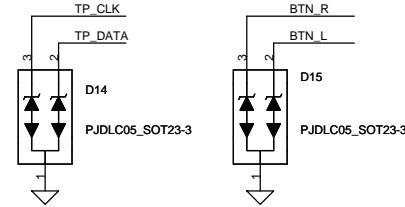
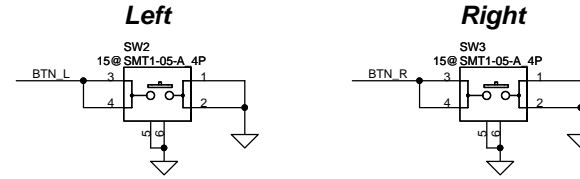

Change to SCA00000200

INT_KBD Conn.



KB1 for 15"
KB2 for 17"

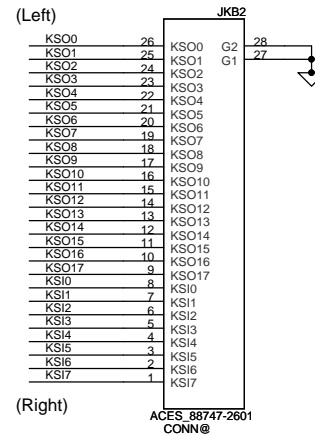
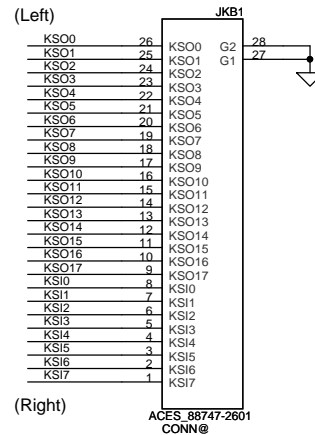
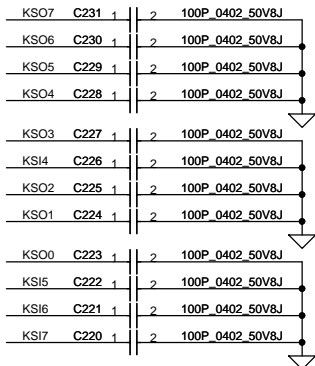
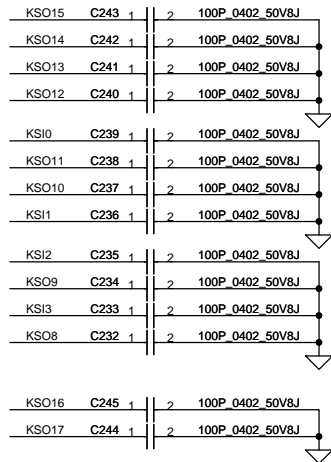

Security Classification	Compal Secret Data		Title	
Issued Date	2005/03/08	Deciphered Date	2010/03/12	Compal Electronics, Inc.
THIS SHEET OF ENGINEERING DRAWING IS THE PROPRIETARY PROPERTY OF COMPAL ELECTRONICS, INC. AND CONTAINS CONFIDENTIAL AND TRADE SECRET INFORMATION. THIS SHEET MAY NOT BE TRANSFERRED FROM THE CUSTODY OF THE COMPETENT DIVISION OF R&D DEPARTMENT EXCEPT AS AUTHORIZED BY COMPAL ELECTRONICS, INC. NEITHER THIS SHEET NOR THE INFORMATION IT CONTAINS MAY BE USED BY OR DISCLOSED TO ANY THIRD PARTY WITHOUT PRIOR WRITTEN CONSENT OF COMPAL ELECTRONICS, INC.				SCHEMATIC, MB A5481
Size	Custom	Document Number	401743	Rev C
Date:	Wednesday, June 24, 2009	Sheet	29 of 47	

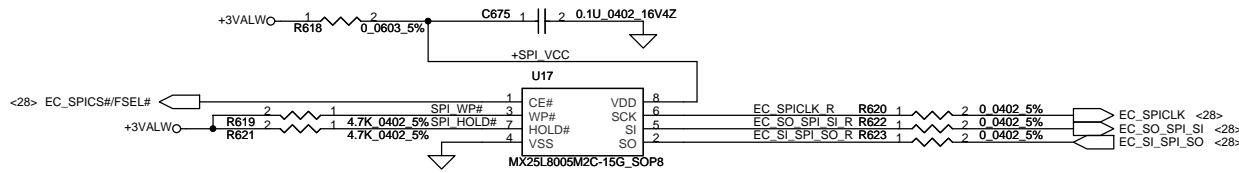

SA00000XT00 : S IC FL 8M MX25L8005M2C-15G SOP 8P
 ENE suggestion SPI Frequency over 66MHz
 SST: 50MHz
 MXIC: 70MHz
 ST: 40MHz

ONLY MXIC used in this project (66MHz)

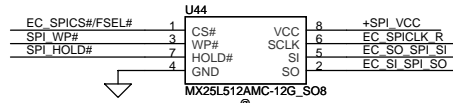
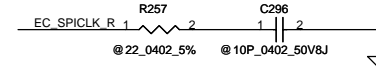

**Reserved for BIOS simulator.
 Footprint S08
 SPI ROM Footprint 150mil**

Security Classification	Compal Secret Data		Compal Electronics, Inc.	
Issued Date	2005/03/08	Deciphered Date	2010/03/12	Title
THIS SHEET OF ENGINEERING DRAWING IS THE PROPRIETARY PROPERTY OF COMPAL ELECTRONICS, INC. AND CONTAINS CONFIDENTIAL AND TRADE SECRET INFORMATION. THIS SHEET MAY NOT BE TRANSFERRED FROM THE CUSTODY OF THE COMPETENT DIVISION OF R&D DEPARTMENT EXCEPT AS AUTHORIZED BY COMPAL ELECTRONICS, INC. NEITHER THIS SHEET NOR THE INFORMATION IT CONTAINS MAY BE USED BY OR DISCLOSED TO ANY THIRD PARTY WITHOUT PRIOR WRITTEN CONSENT OF COMPAL ELECTRONICS, INC.				Document Number
				401743
				Rev C
Date: Wednesday, June 24, 2009		Sheet 30 of 47		

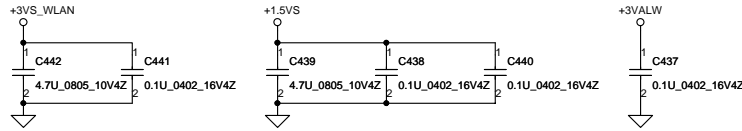

For Wireless LAN

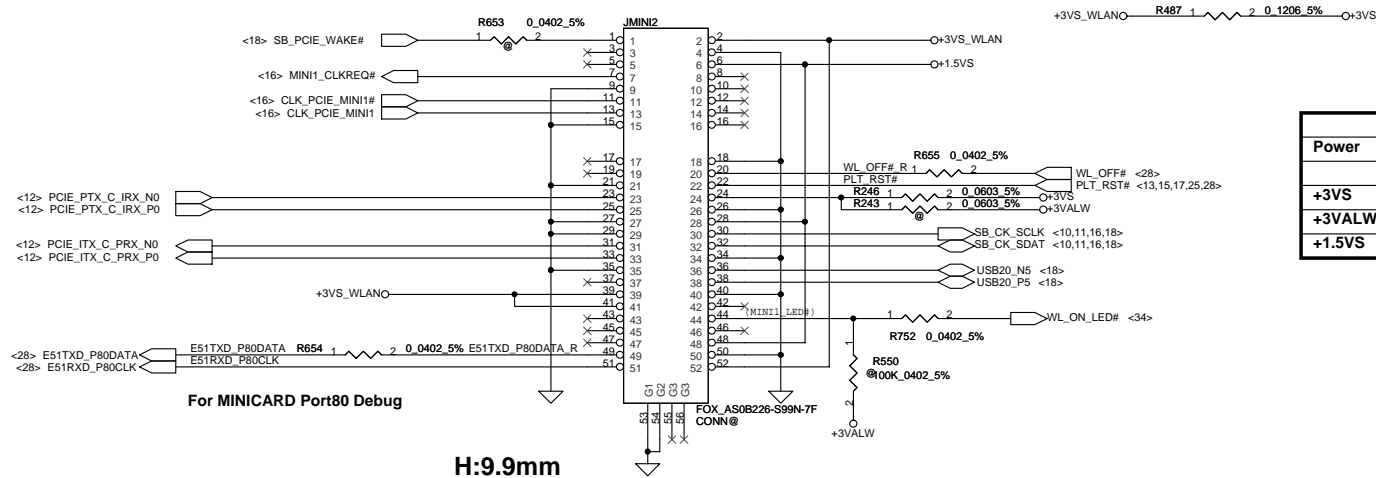

Mini Card Power Rating			
Power	Primary Power (mA)		Auxiliary Power (mA)
	Peak	Normal	Normal
+3VS	1000	750	
+3VALW	330	250	250 (wake enable)
+1.5VS	500	375	5 (Not wake enable)

USB CONN. 1 & 2

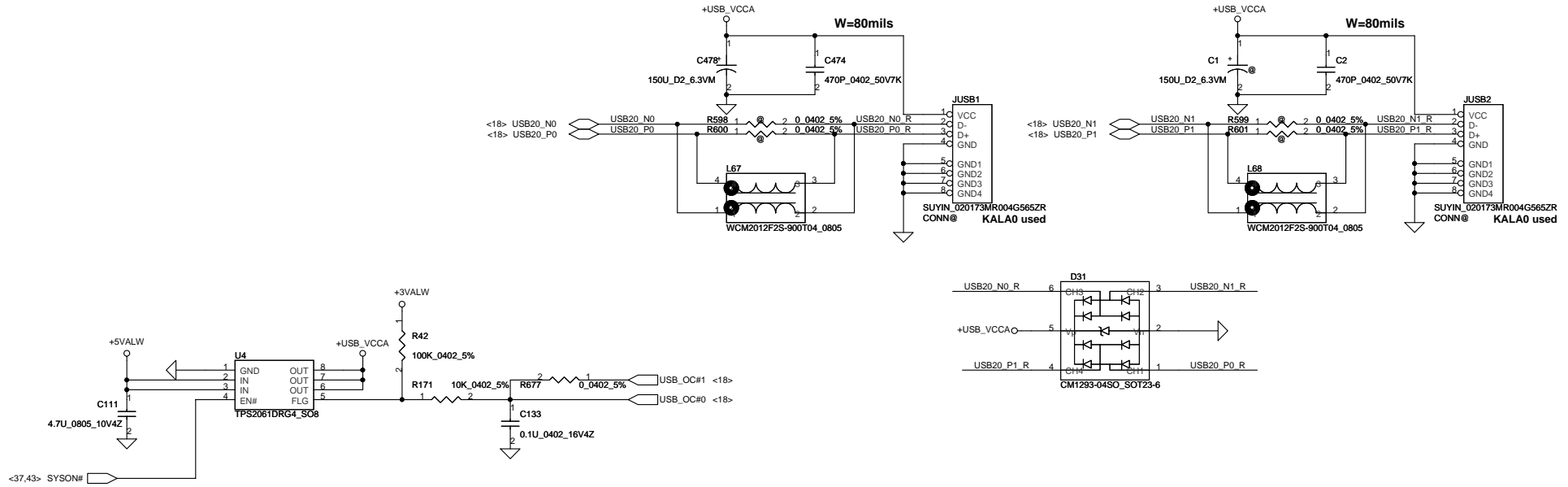

Security Classification	Compal Secret Data			Compal Electronics, Inc.		
Issued Date	2005/06/20	Deciphered Date	2010/03/12	Title	SCHEMATIC, MB A5481	
THIS SHEET OF ENGINEERING DRAWING IS THE PROPRIETARY PROPERTY OF COMPAL ELECTRONICS, INC. AND CONTAINS CONFIDENTIAL AND TRADE SECRET INFORMATION. THIS SHEET MAY NOT BE TRANSFERRED FROM THE CUSTODY OF THE COMPETENT DIVISION OF R&D DEPARTMENT EXCEPT AS AUTHORIZED BY COMPAL ELECTRONICS, INC. NEITHER THIS SHEET NOR THE INFORMATION IT CONTAINS MAY BE USED BY OR DISCLOSED TO ANY THIRD PARTY WITHOUT PRIOR WRITTEN CONSENT OF COMPAL ELECTRONICS, INC.				Document Number	401743	Rev C
				Date:	Wednesday, June 24, 2009	Sheet 32 of 47

Power ON Circuit

For South Bridge

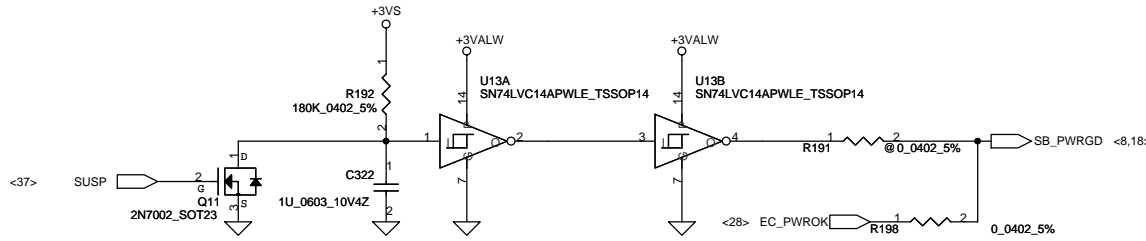

note: T1 minimum 15ms, T2 minimum 33ms/maximum 500ms, SUSP# goes to low after SB_PWRGD goes to low for power down.

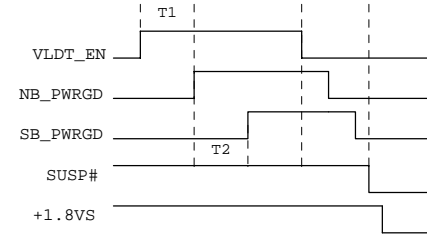

For +1.2HT

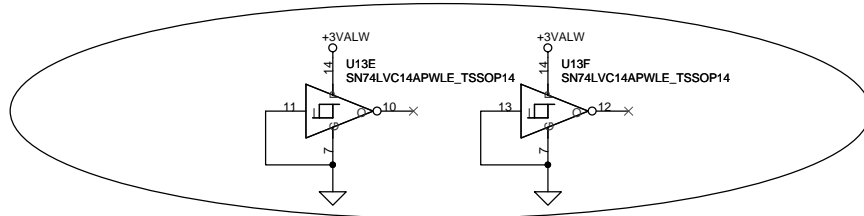
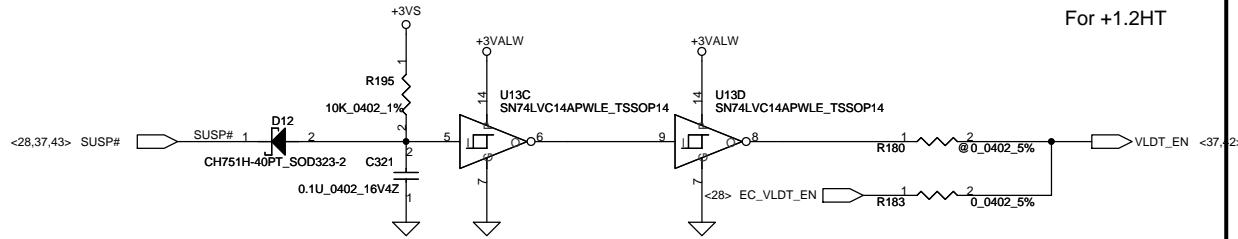

Power Button

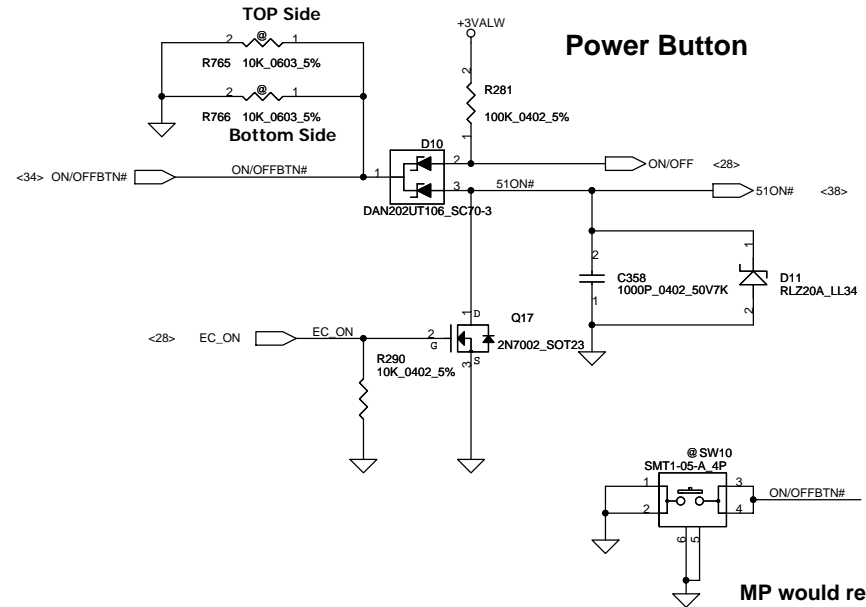

MP would remove

Security Classification		Compal Secret Data		Compal Electronics, Inc.	
Issued Date	2005/03/08	Deciphered Date	2010/03/12	Title	SCHMATIC, MB A5481
THIS SHEET OF ENGINEERING DRAWING IS THE PROPRIETARY PROPERTY OF COMPAL ELECTRONICS, INC. AND CONTAINS CONFIDENTIAL AND TRADE SECRET INFORMATION. THIS SHEET MAY NOT BE TRANSFERRED FROM THE CUSTODY OF THE COMPETENT DIVISION OF R&D DEPARTMENT EXCEPT AS AUTHORIZED BY COMPAL ELECTRONICS, INC. NEITHER THIS SHEET NOR THE INFORMATION IT CONTAINS MAY BE USED BY OR DISCLOSED TO ANY THIRD PARTY WITHOUT PRIOR WRITTEN CONSENT OF COMPAL ELECTRONICS, INC.				Size	Document Number
				B	401743
				Date:	Wednesday, June 24, 2009
				Sheet	33 of 47
				Rev	C

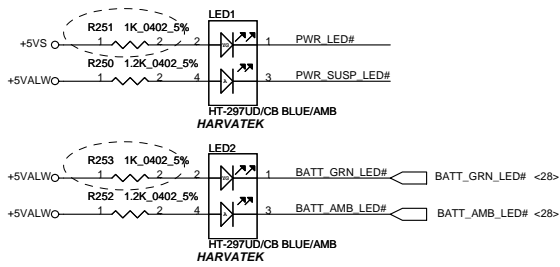
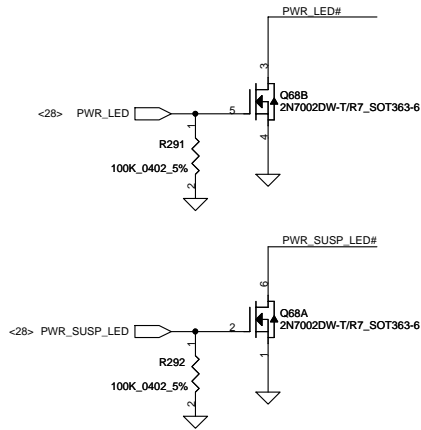

BLUE/AMB LED

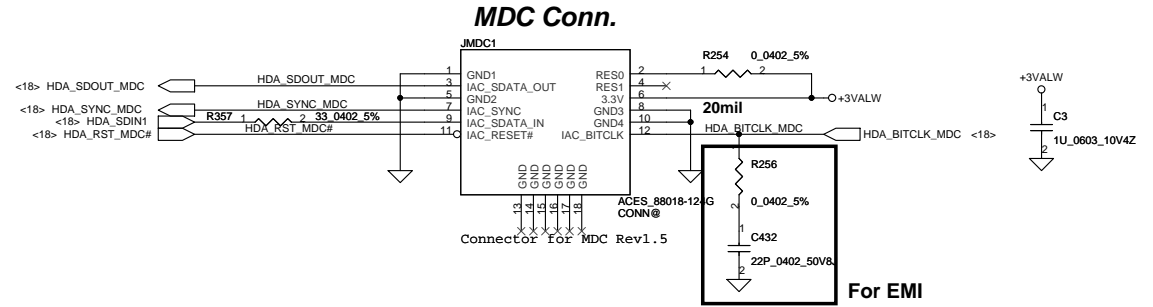

To PWR LED/B

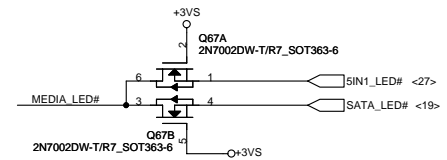
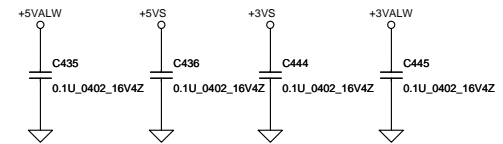
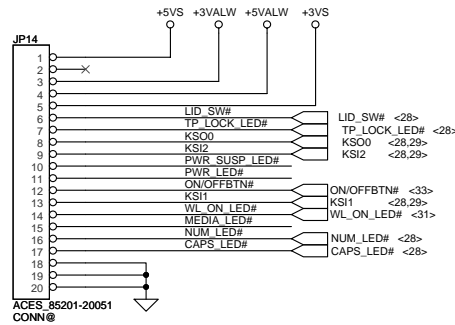

	KSO0
KSI1	WL_BTN#
KSI2	TP_LOCK_BTN#
KSI3	
KSI4	
KSI5	
KSI6	

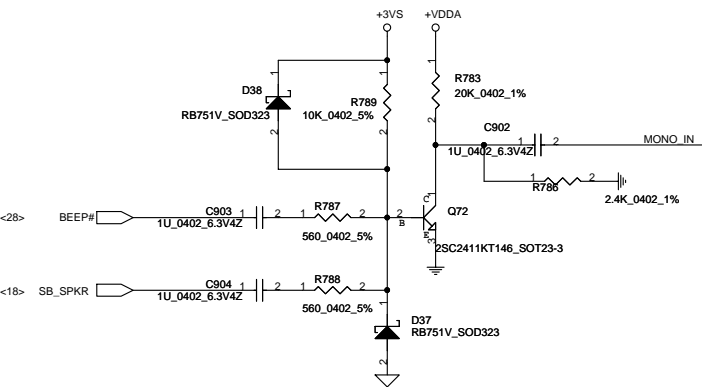

HD Audio Codec

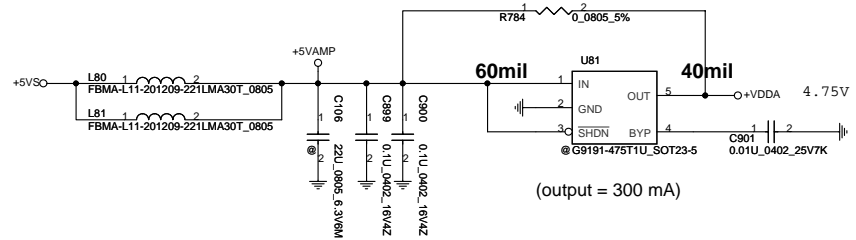

(output = 300 mA)

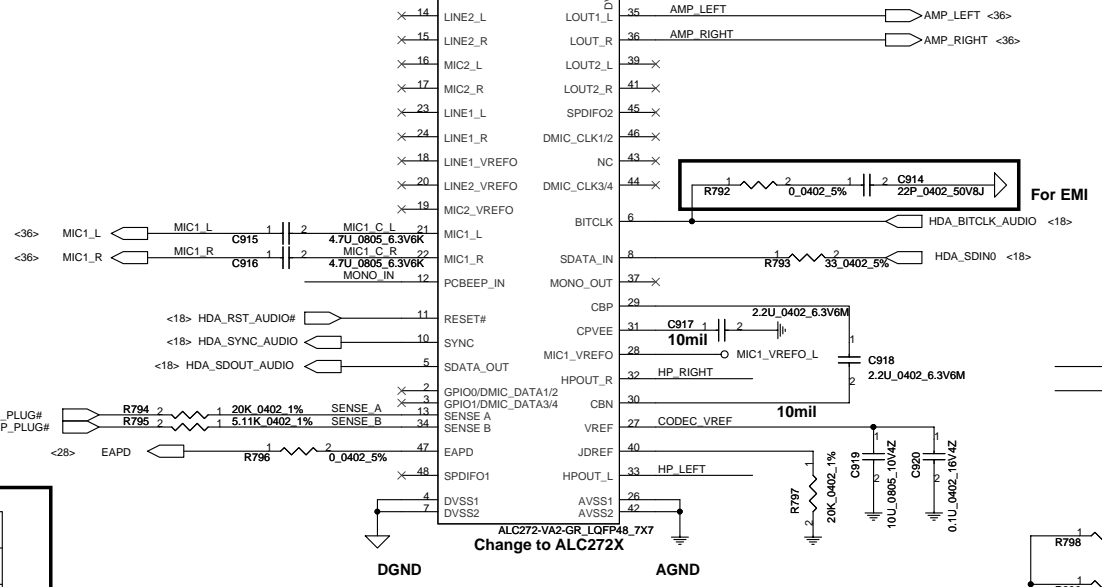
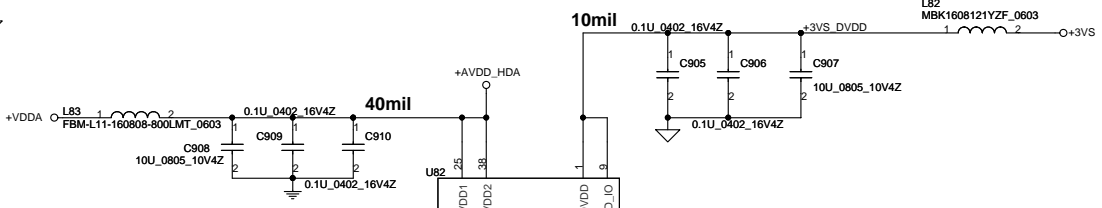

For EMI

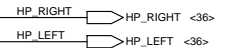

update this table

Sense Pin	Impedance	Codec Signals
SENSE A	39.2K	PORT-A (PIN 39, 41)
	20K	PORT-B (PIN 21, 22)
	10K	PORT-C (PIN 23, 24)
	5.1K	PORT-D (PIN 35, 36)
SENSE B	39.2K	PORT-E (PIN 14, 15)
	20K	PORT-F (PIN 16, 17)
	10K	PORT-G (PIN 43, 44)
	5.1K	PORT-H (PIN 45, 46)

Change to ALC272X

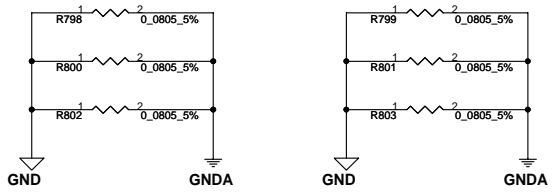

Security Classification	Compal Secret Data			Title	
Issued Date	2007/09/20	Deciphered Date	2010/03/12	SCHEMATIC, MB A5481	
THIS SHEET OF ENGINEERING DRAWING IS THE PROPRIETARY PROPERTY OF COMPAL ELECTRONICS, INC. AND CONTAINS CONFIDENTIAL AND TRADE SECRET INFORMATION. THIS SHEET MAY NOT BE TRANSFERRED FROM THE CUSTODY OF THE COMPETENT DIVISION OF R&D DEPARTMENT EXCEPT AS AUTHORIZED BY COMPAL ELECTRONICS, INC. NEITHER THIS SHEET NOR THE INFORMATION IT CONTAINS MAY BE USED BY OR DISCLOSED TO ANY THIRD PARTY WITHOUT PRIOR WRITTEN CONSENT OF COMPAL ELECTRONICS, INC.				Rev	C
Date: Wednesday, June 24, 2009				Sheet	35 of 47

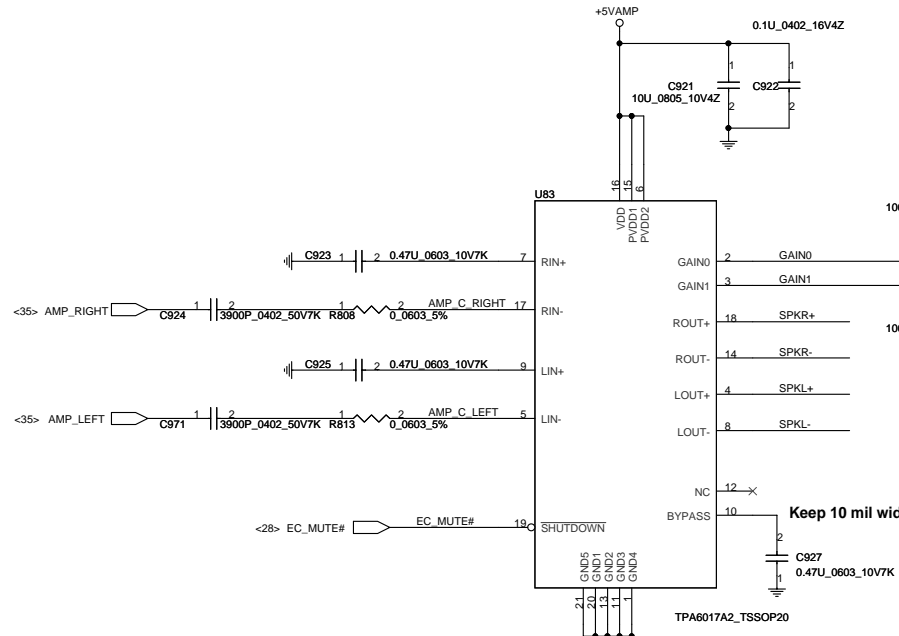

Int. Speaker Conn.

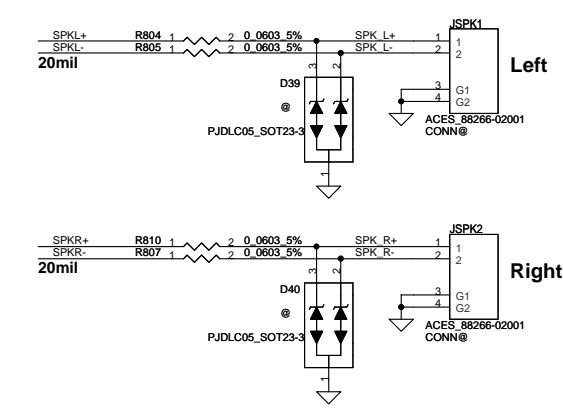

LINE Out/Headphone Out

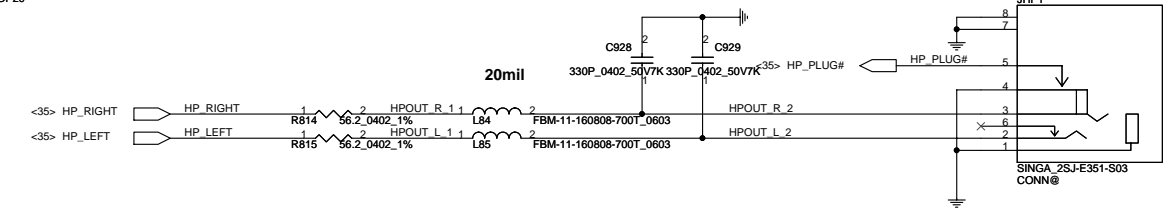

MIC JACK

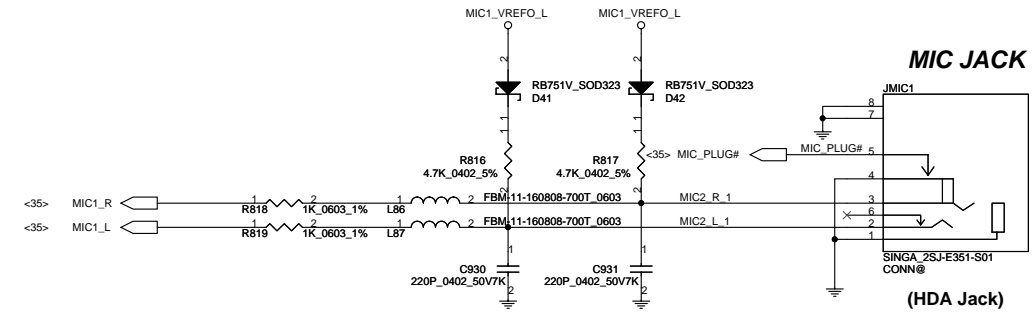

Security Classification		Compal Secret Data		Title	
Issued Date	2007/09/20	Deciphered Date	2010/03/12	Compal Electronics, Inc.	
THIS SHEET OF ENGINEERING DRAWING IS THE PROPRIETARY PROPERTY OF COMPAL ELECTRONICS, INC. AND CONTAINS CONFIDENTIAL AND TRADE SECRET INFORMATION. THIS SHEET MAY NOT BE TRANSFERRED FROM THE CUSTODY OF THE COMPETENT DIVISION OF R&D DEPARTMENT EXCEPT AS AUTHORIZED BY COMPAL ELECTRONICS, INC. NEITHER THIS SHEET NOR THE INFORMATION IT CONTAINS MAY BE USED BY OR DISCLOSED TO ANY THIRD PARTY WITHOUT PRIOR WRITTEN CONSENT OF COMPAL ELECTRONICS, INC.				Document Number	Rev
				401743	C
Date: Wednesday, June 24, 2009				Sheet	36 of 47

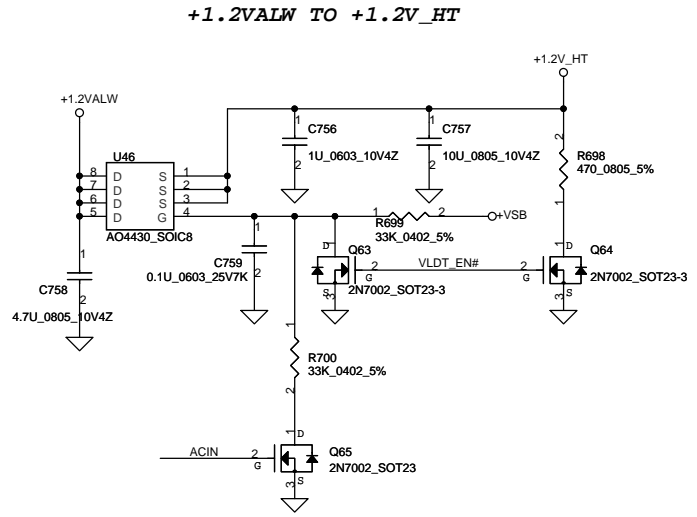
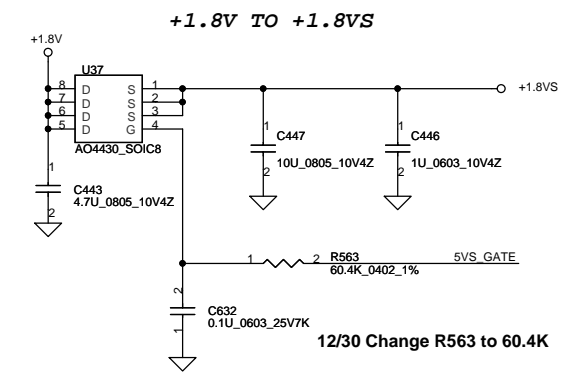
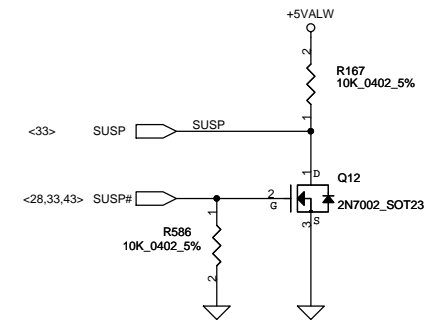
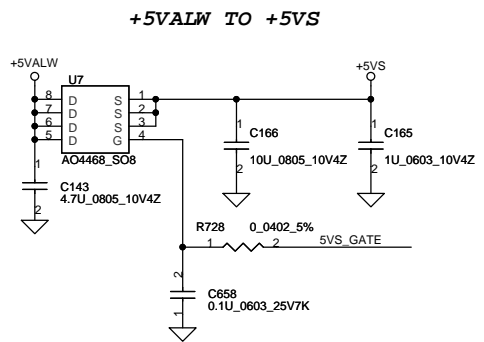
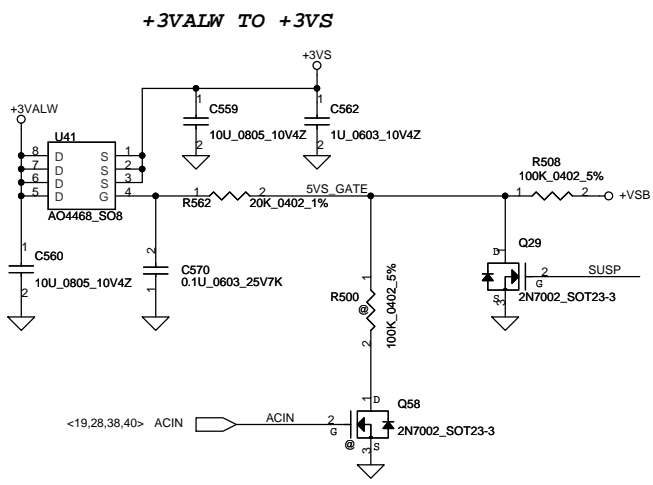

For PWR request

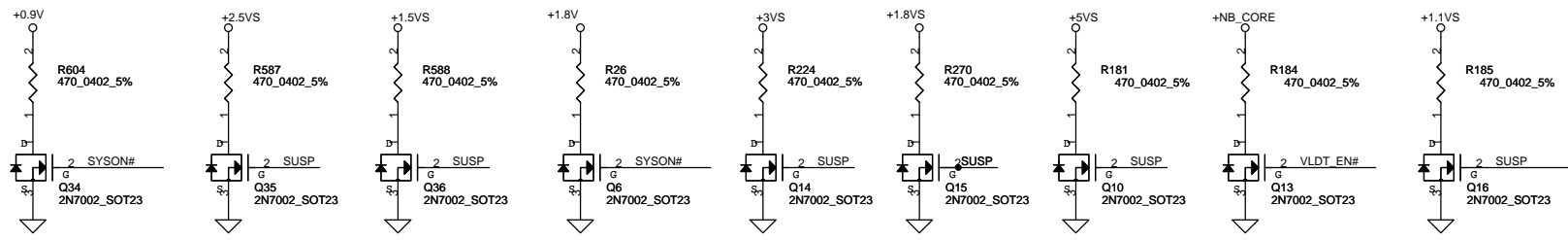
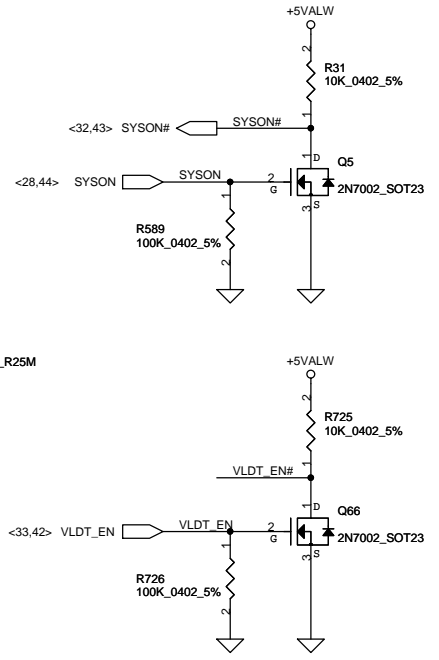

Security Classification		Compal Secret Data		Compal Electronics, Inc.	
Issued Date	2005/03/08	Deciphered Date	2010/03/12	Title	
THIS SHEET OF ENGINEERING DRAWING IS THE PROPRIETARY PROPERTY OF COMPAL ELECTRONICS, INC. AND CONTAINS CONFIDENTIAL AND TRADE SECRET INFORMATION. THIS SHEET MAY NOT BE TRANSFERRED FROM THE CUSTODY OF THE COMPETENT DIVISION OF R&D DEPARTMENT EXCEPT AS AUTHORIZED BY COMPAL ELECTRONICS, INC. NEITHER THIS SHEET NOR THE INFORMATION IT CONTAINS MAY BE USED BY OR DISCLOSED TO ANY THIRD PARTY WITHOUT PRIOR WRITTEN CONSENT OF COMPAL ELECTRONICS, INC.				Document Number	Rev
				401743	C
Date: Wednesday, June 24, 2009				Sheet	37 of 47

DC231000500

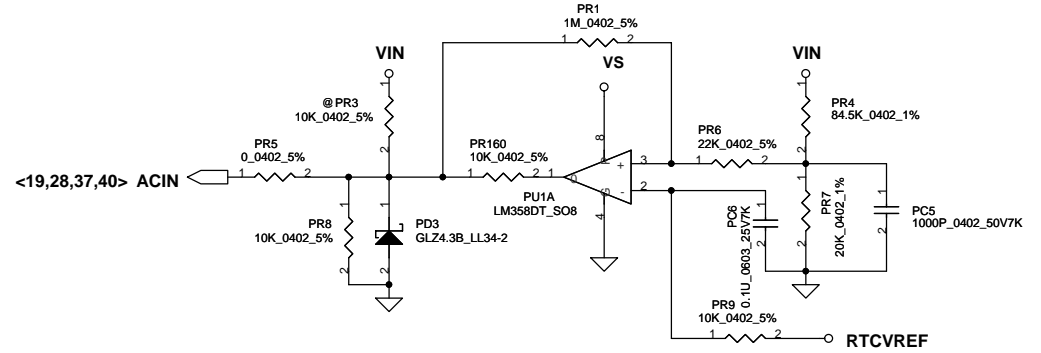
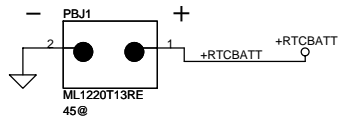
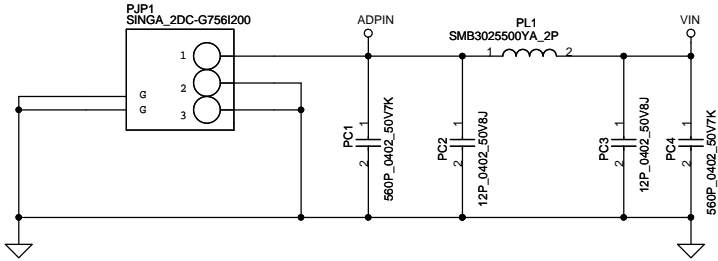

Vin Detector			
	Min.	Typ	Max.
H-->L	16.976V	17.525V	17.728V
L-->H	17.430V	17.901V	18.384V

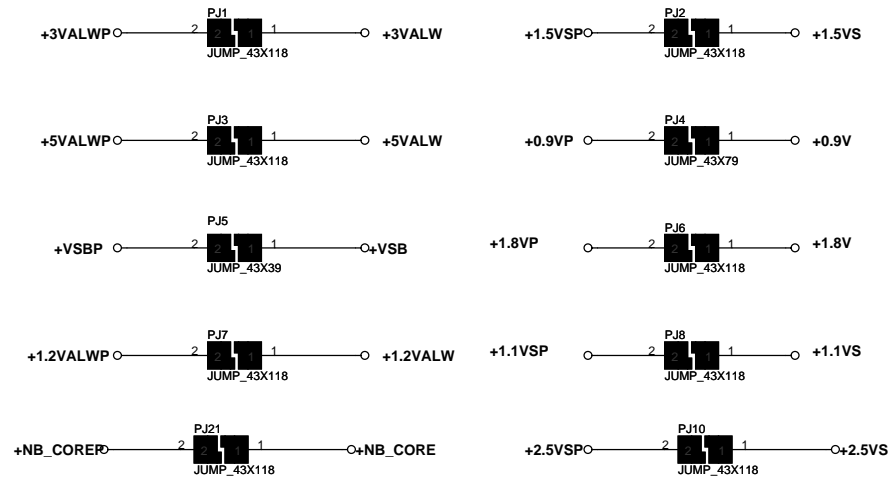
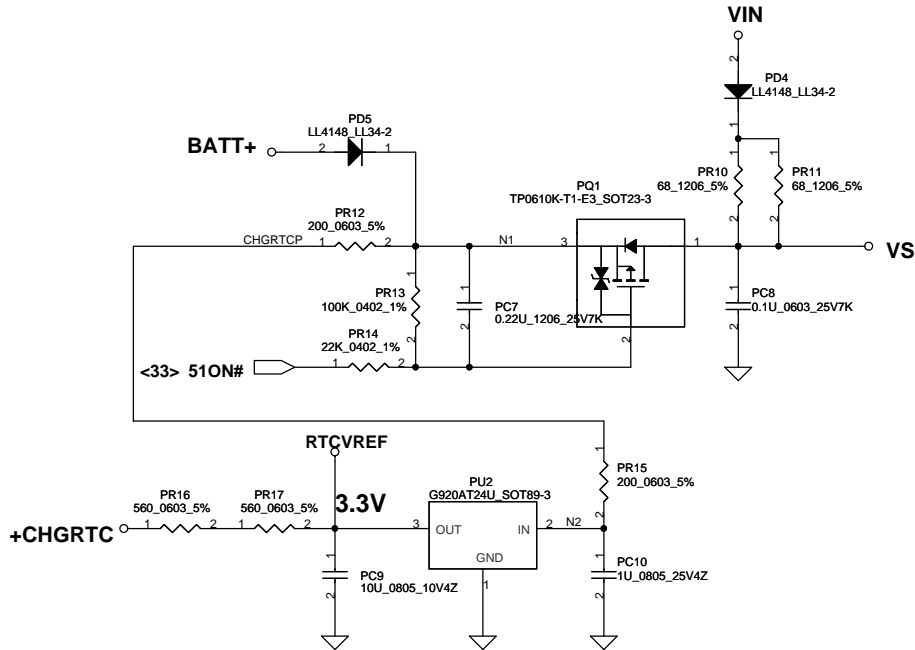

Security Classification		Compal Secret Data		Compal Electronics, Inc.	
Issued Date	2008/06/11	Deciphered Date	2010/03/12	Title	SCHMATIC, MB A5481
THIS SHEET OF ENGINEERING DRAWING IS THE PROPRIETARY PROPERTY OF COMPAL ELECTRONICS, INC. AND CONTAINS CONFIDENTIAL AND TRADE SECRET INFORMATION. THIS SHEET MAY NOT BE TRANSFERRED FROM THE CUSTODY OF THE COMPETENT DIVISION OF R&D DEPARTMENT EXCEPT AS AUTHORIZED BY COMPAL ELECTRONICS, INC. NEITHER THIS SHEET NOR THE INFORMATION IT CONTAINS MAY BE USED BY OR DISCLOSED TO ANY THIRD PARTY WITHOUT PRIOR WRITTEN CONSENT OF COMPAL ELECTRONICS, INC.					
Size B	Document Number	Rev C	Date: Wednesday, June 24, 2009 Sheet 38 of 47		
	401743				

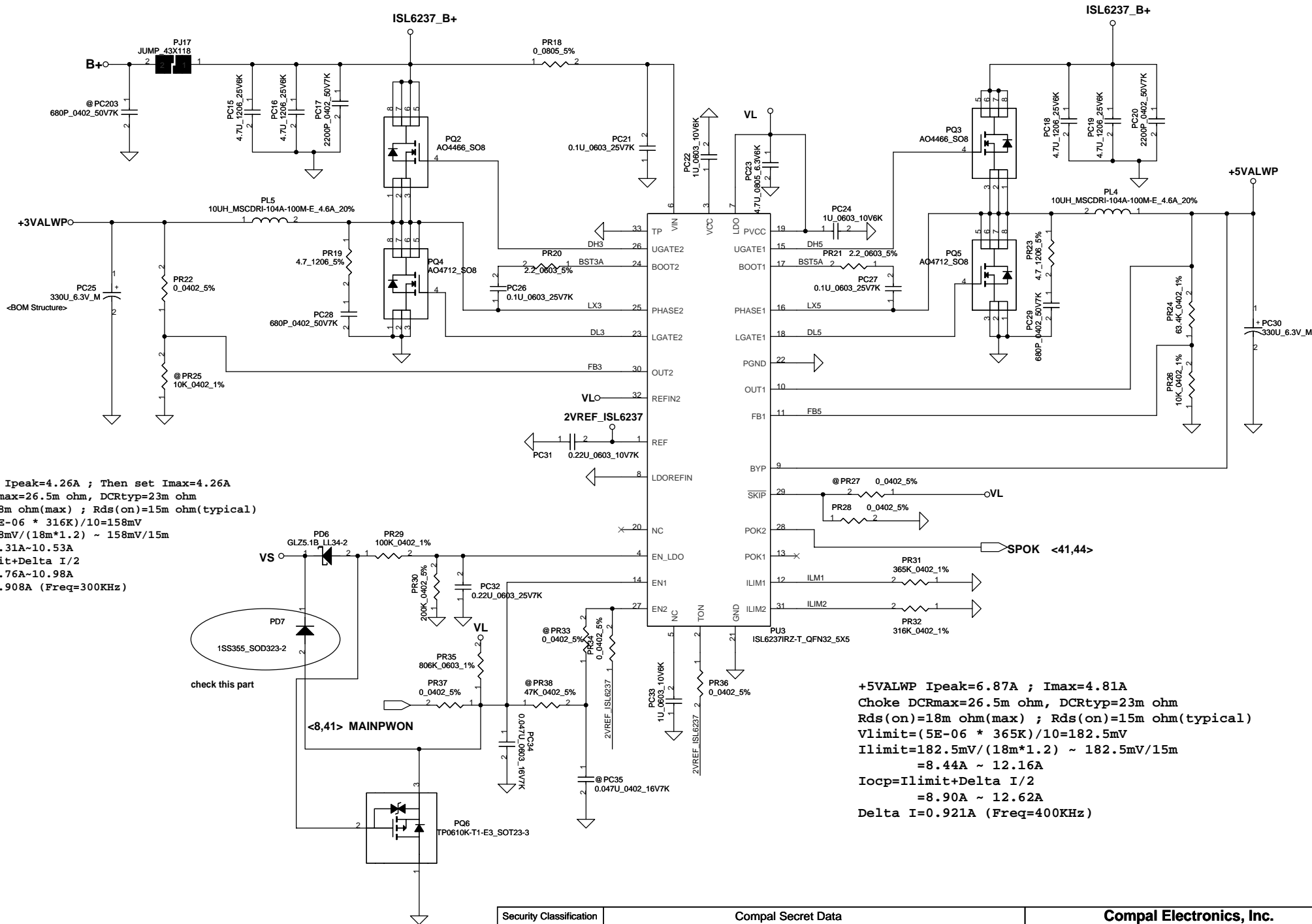

+3.3VALWP Ipeak=4.26A ; Then set I_{max}=4.26A
 Choke DCR_{max}=26.5m ohm, DCR_{typ}=23m ohm
 R_{ds(on)}=18m ohm(max) ; R_{ds(on)}=15m ohm(typical)
 V_{limit}=(5E-06 * 316K)/10=158mV
 I_{limit}=158mV/(18m*1.2) ~ 158mV/15m
 =7.31A~10.53A
 I_{ocp}=I_{limit}+Delta I/2
 =7.76A~10.98A
 Delta I=0.908A (Freq=300KHz)

+5VALWP Ipeak=6.87A ; I_{max}=4.81A
 Choke DCR_{max}=26.5m ohm, DCR_{typ}=23m ohm
 R_{ds(on)}=18m ohm(max) ; R_{ds(on)}=15m ohm(typical)
 V_{limit}=(5E-06 * 365K)/10=182.5mV
 I_{limit}=182.5mV/(18m*1.2) ~ 182.5mV/15m
 =8.44A ~ 12.16A
 I_{ocp}=I_{limit}+Delta I/2
 =8.90A ~ 12.62A
 Delta I=0.921A (Freq=400KHz)

check this part
 PD7
 1SS355_SOD323-2

Security Classification		Compal Secret Data		Compal Electronics, Inc.	
Issued Date	2008/06/11	Deciphered Date	2010/03/12	Title	SCHMATIC, MB A5481
THIS SHEET OF ENGINEERING DRAWING IS THE PROPRIETARY PROPERTY OF COMPAL ELECTRONICS, INC. AND CONTAINS CONFIDENTIAL AND TRADE SECRET INFORMATION. THIS SHEET MAY NOT BE TRANSFERRED FROM THE CUSTODY OF THE COMPETENT DIVISION OF R&D DEPARTMENT EXCEPT AS AUTHORIZED BY COMPAL ELECTRONICS, INC. NEITHER THIS SHEET NOR THE INFORMATION IT CONTAINS MAY BE USED BY OR DISCLOSED TO ANY THIRD PARTY WITHOUT PRIOR WRITTEN CONSENT OF COMPAL ELECTRONICS, INC.					
Size	Document Number	Rev			
Custom	401743	C			
Date:	Wednesday, June 24, 2009	Sheet	39	of	47

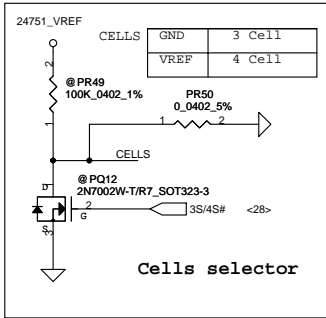
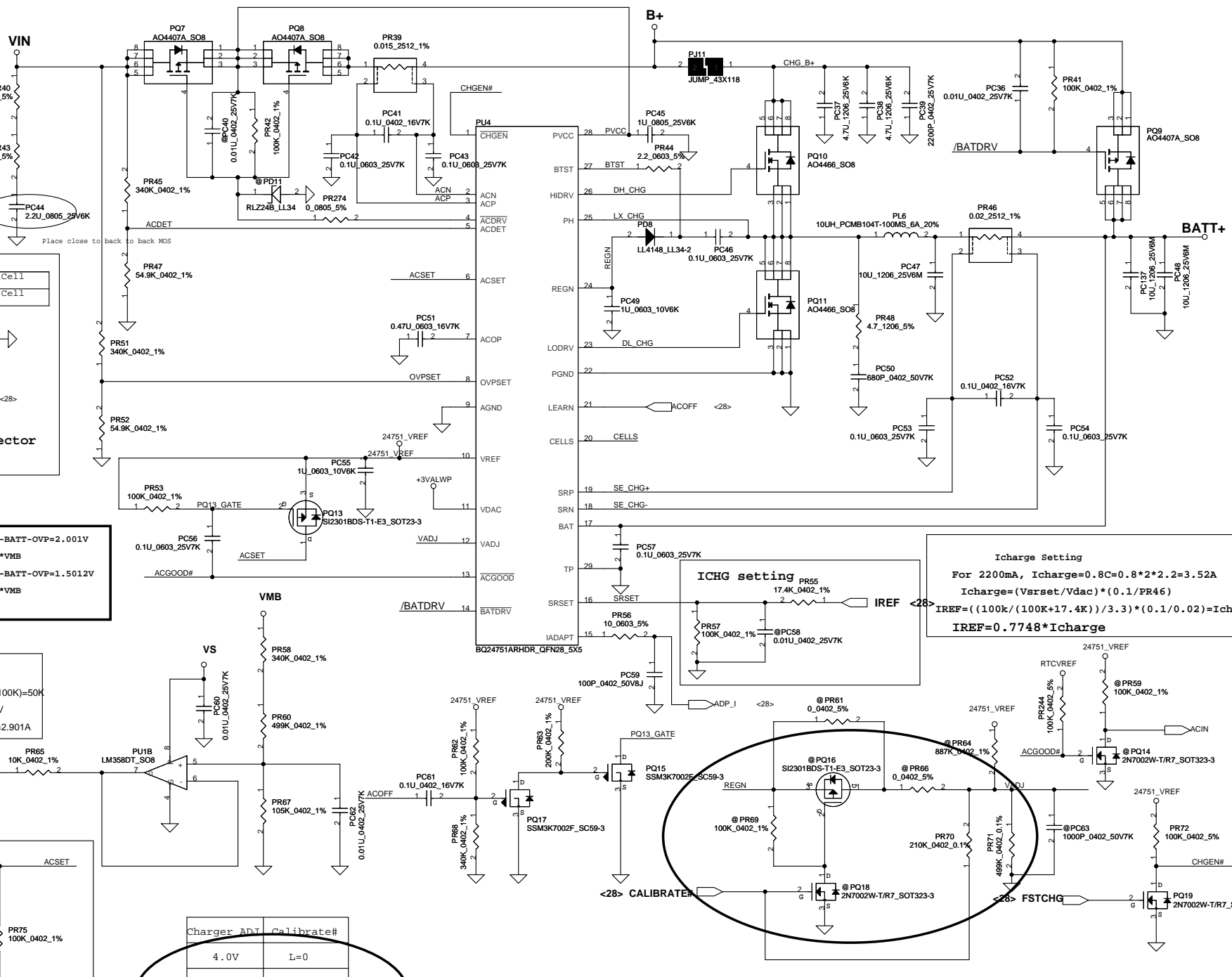

Input OVP : 22.3V
 Input UVP : 17.26V
 Fsw : 300KHz

LI-4S : 18.0V----BATT-OVP=2.001V
 BATT-OVP=0.1112*VMB
 LI-3S : 13.5V----BATT-OVP=1.5012V
 BATT-OVP=0.1112*VMB
 per cell=3.5V

CP Point Setting
 CP point=ladapter*85%
 65W adapter R=(100K*100K)/(100K+100K)=50K
 Vacset=3.3*(50K/(50K+64.9K))=1.436V
 CP POINT=(1.436V/3.3V)*(0.1/0.015)=2.901A

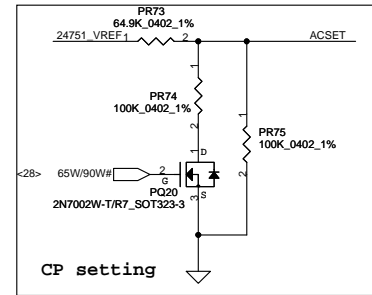

Charger ADI	Calibrate#
4.0V	L=0
4.2V	1.8755V
4.3V	2.8132V
4.35V	H=3.3V

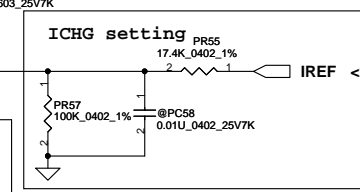

Icharge Setting
 For 2200mA, Icharge=0.8C=0.8*2*2.2=3.52A
 Icharge=(Vsrset/Vdac)*(0.1/PR46)
 IREF=((100k/(100K+17.4K))/3.3)*(0.1/0.02)=Icharge
 IREF=0.7748*Icharge

PH1 under CPU botten side :
CPU thermal protection at 92 degree C

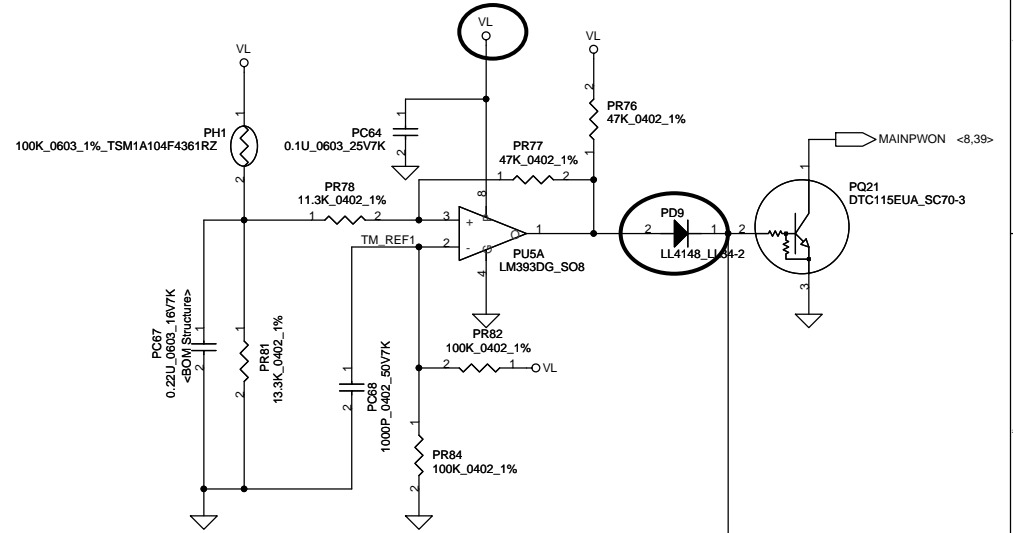

PH2 near main Battery CONN :
BAT. thermal protection at 75 degree C

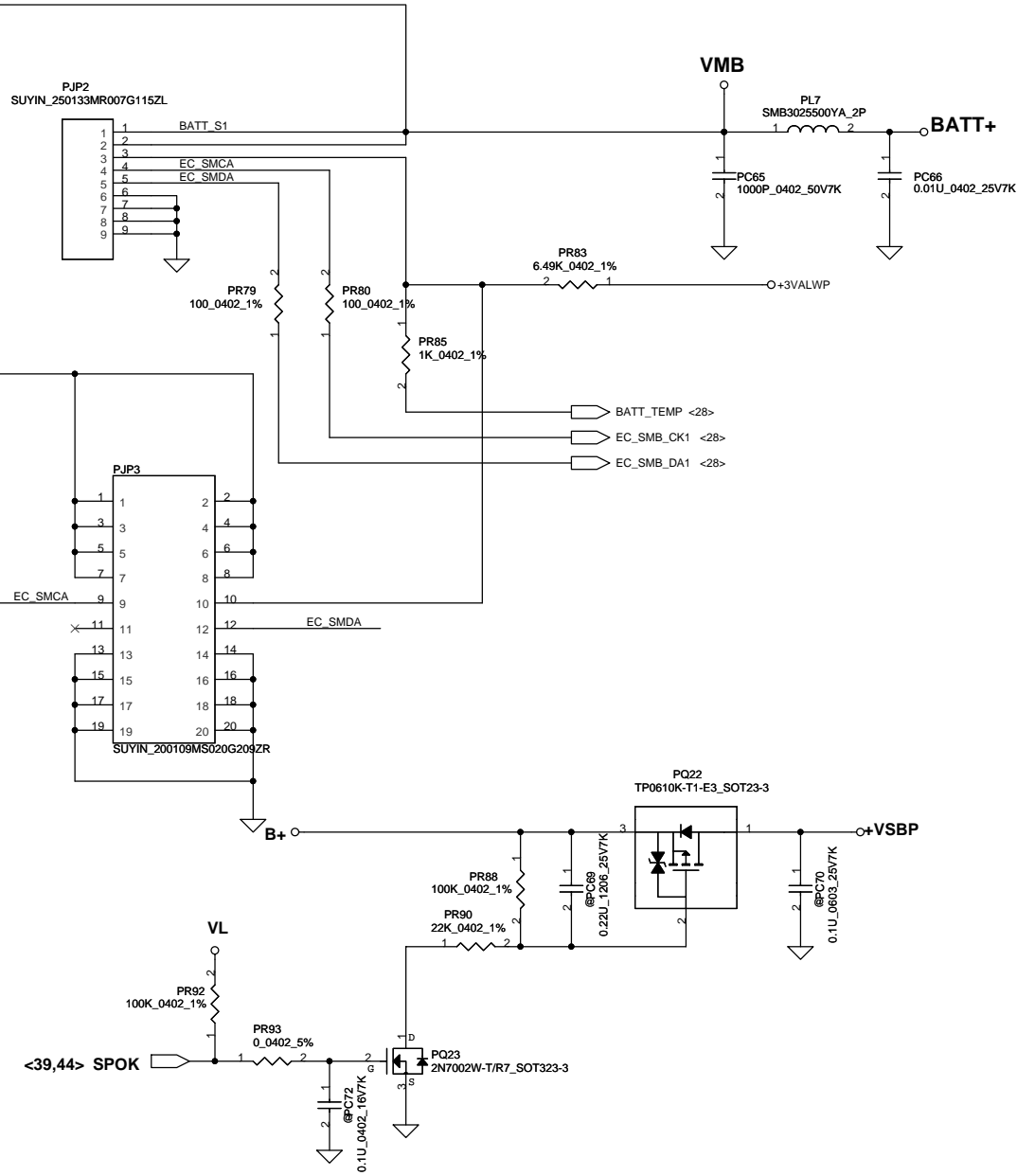
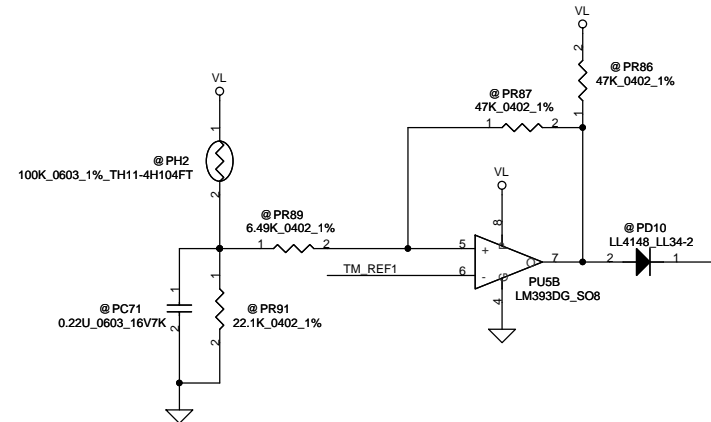

Security Classification		Compal Secret Data		Compal Electronics, Inc.	
Issued Date	2008/06/11	Deciphered Date	2010/03/12	Title	SCHEMATIC, MB A5481
THIS SHEET OF ENGINEERING DRAWING IS THE PROPRIETARY PROPERTY OF COMPAL ELECTRONICS, INC. AND CONTAINS CONFIDENTIAL AND TRADE SECRET INFORMATION. THIS SHEET MAY NOT BE TRANSFERRED FROM THE CUSTODY OF THE COMPETENT DIVISION OF R&D DEPARTMENT EXCEPT AS AUTHORIZED BY COMPAL ELECTRONICS, INC. NEITHER THIS SHEET NOR THE INFORMATION IT CONTAINS MAY BE USED BY OR DISCLOSED TO ANY THIRD PARTY WITHOUT PRIOR WRITTEN CONSENT OF COMPAL ELECTRONICS, INC.					
Size	Document Number	Rev			
B	401743	C			
Date:	Wednesday, June 24, 2009	Sheet	41	of	47

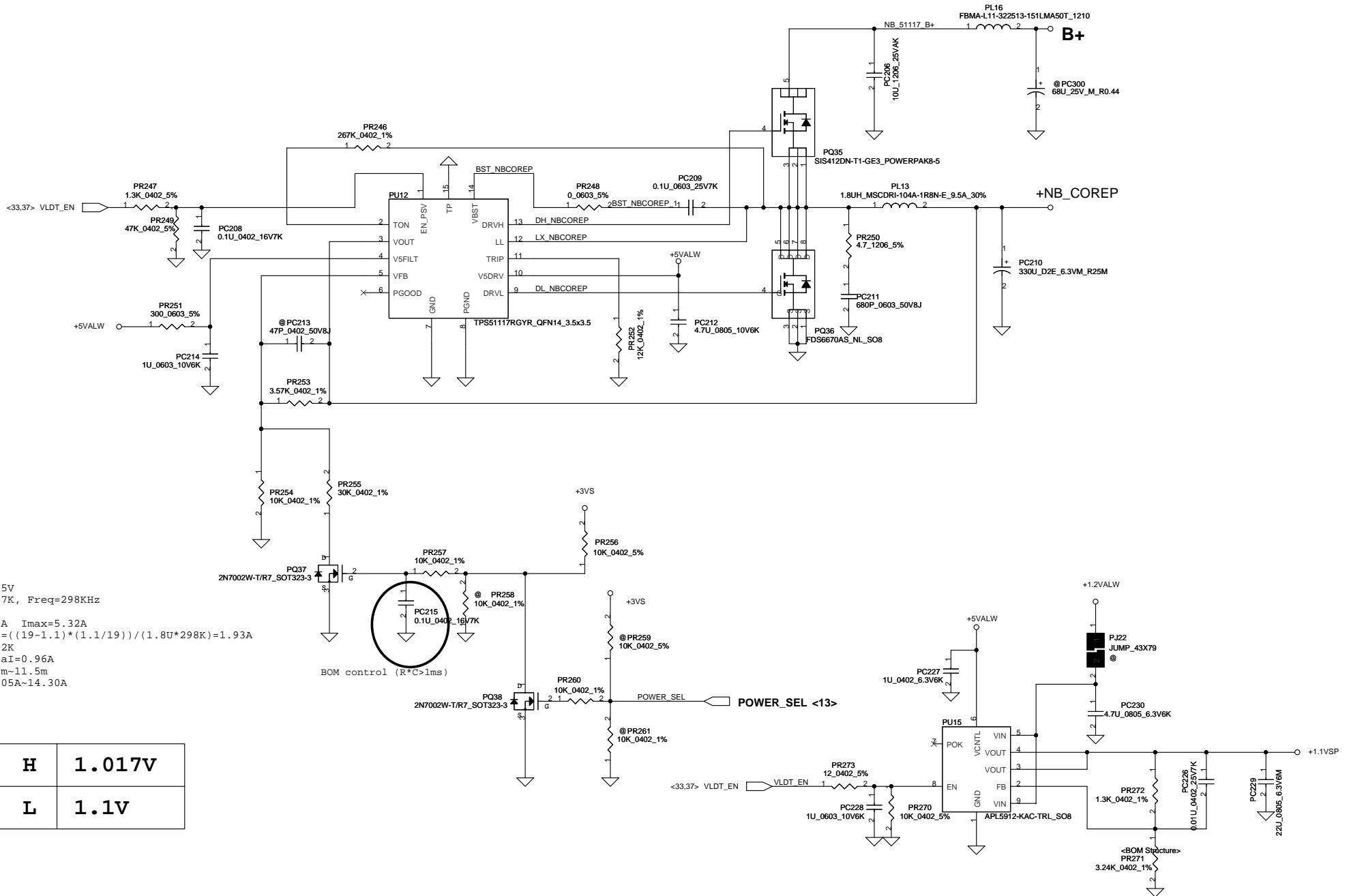

VFB=0.75V
 Rton=267K, Freq=298KHz
 Ipeak=7A Imax=5.32A
 $\Delta I = ((19-1.1) * (1.1/19)) / (1.8U * 298K) = 1.93A$
 Rtrip=12K
 $1/2 \Delta I = 0.96A$
 Rdson=9m~11.5m
 Iocp=9.05A~14.30A

BOM control (R*C>1ms)

H	1.017V
L	1.1V

Security Classification	Compal Secret Data		Title	
Issued Date	2008/11/03	Deciphered Date	2010/03/12	Compal Electronics, Inc.
THIS SHEET OF ENGINEERING DRAWING IS THE PROPRIETARY PROPERTY OF COMPAL ELECTRONICS, INC. AND CONTAINS CONFIDENTIAL AND TRADE SECRET INFORMATION. THIS SHEET MAY NOT BE TRANSFERRED FROM THE CUSTODY OF THE COMPETENT DIVISION OF R&D DEPARTMENT EXCEPT AS AUTHORIZED BY COMPAL ELECTRONICS, INC. NEITHER THIS SHEET NOR THE INFORMATION IT CONTAINS MAY BE USED BY OR DISCLOSED TO ANY THIRD PARTY WITHOUT PRIOR WRITTEN CONSENT OF COMPAL ELECTRONICS, INC.				SCHEMATIC, MB A5481 Document Number 401743 Date: Wednesday, June 24, 2009 Sheet 42 of 47

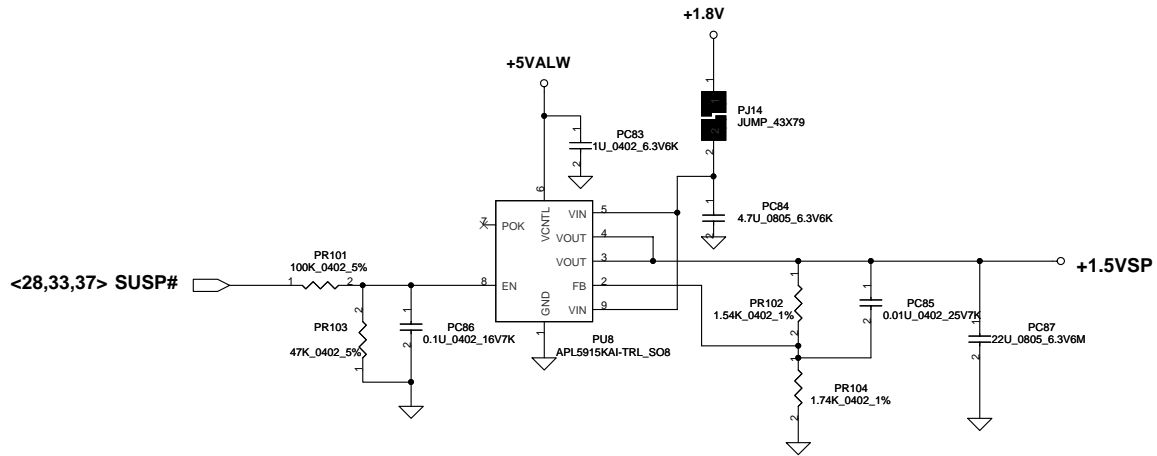
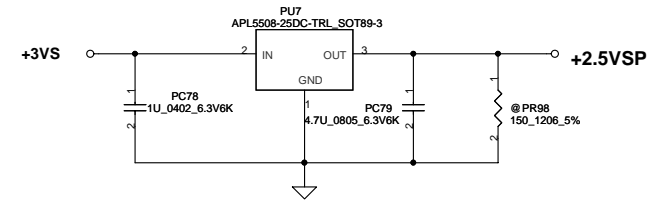
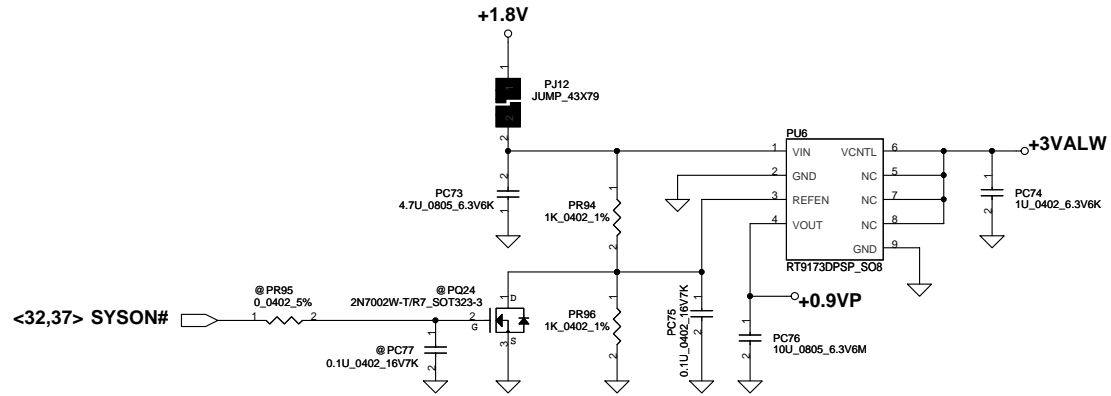

Security Classification	Compal Secret Data			Compal Electronics, Inc.	
Issued Date	2008/06/11	Deciphered Date	2010/03/12	Title	SCHEMATIC, MB A5481
THIS SHEET OF ENGINEERING DRAWING IS THE PROPRIETARY PROPERTY OF COMPAL ELECTRONICS, INC. AND CONTAINS CONFIDENTIAL AND TRADE SECRET INFORMATION. THIS SHEET MAY NOT BE TRANSFERRED FROM THE CUSTODY OF THE COMPETENT DIVISION OF R&D DEPARTMENT EXCEPT AS AUTHORIZED BY COMPAL ELECTRONICS, INC. NEITHER THIS SHEET NOR THE INFORMATION IT CONTAINS MAY BE USED BY OR DISCLOSED TO ANY THIRD PARTY WITHOUT PRIOR WRITTEN CONSENT OF COMPAL ELECTRONICS, INC.					
Revision	401743	Document Number	401743	Rev	C
Date	Wednesday, June 24, 2009	Sheet	43	of	47

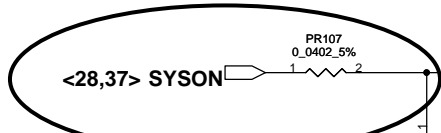

VFB=0.75V
 $V_o = VFB * (1 + PR111 / PR112) = 0.75 * (1 + 14K / 10K) = 1.8V$
 $R_{ton} = 267K \Rightarrow F_{aw} = 297KHz$

Cout ESR=15m ohm
 $I_{peak} = 11.96A, I_{max} = 8.372A$
 $\Delta I = ((19 - 1.8) * (1.8 / 19)) / (L * F_{sw})$
 $((19 - 1.8) * (1.8 / 19)) / (1.8u * 297000) = 3.048A$
 $\Rightarrow 1/2 \Delta I = 1.524A$

Rtrip=16.2K
 $I_{ocp} = 12.39A - 20.69A$

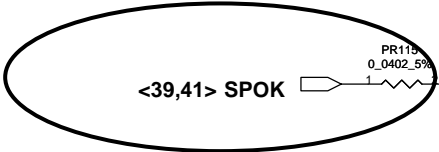
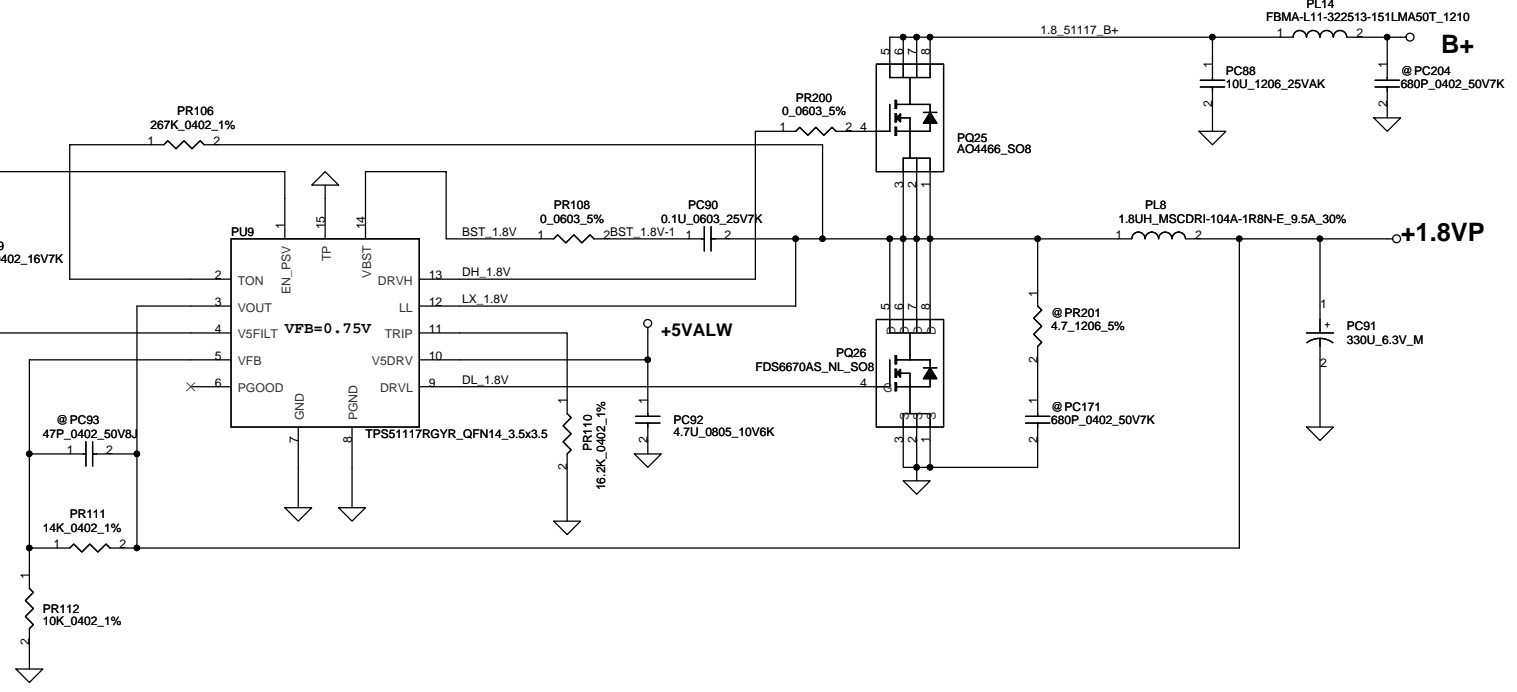

VFB=0.75V
 $V_o = VFB * (1 + PR119 / PR120) = 0.75 * (1 + 6.04K / 10K) = 1.203V$
 $R_{ton} = 267K \Rightarrow F_{sw} = 298KHz$

1.2VP Ipeak=7.4A ; Imax=5.180A
 $\Delta I = ((19 - 1.2) * (1.2 / 19)) / (L * F_{sw})$
 $((19 - 1.2) * (1.2 / 19)) / (1.8u * 298000) = 2.10A$
 $\Rightarrow 1/2 \Delta I = 1.05A$
 $R_{dson} = 11.5m / 9m \text{ ohm}$
 set Rtrip=12K
 $I_{ocp_min} = 9.11A$
 $I_{ocp_max} = 14.38A$

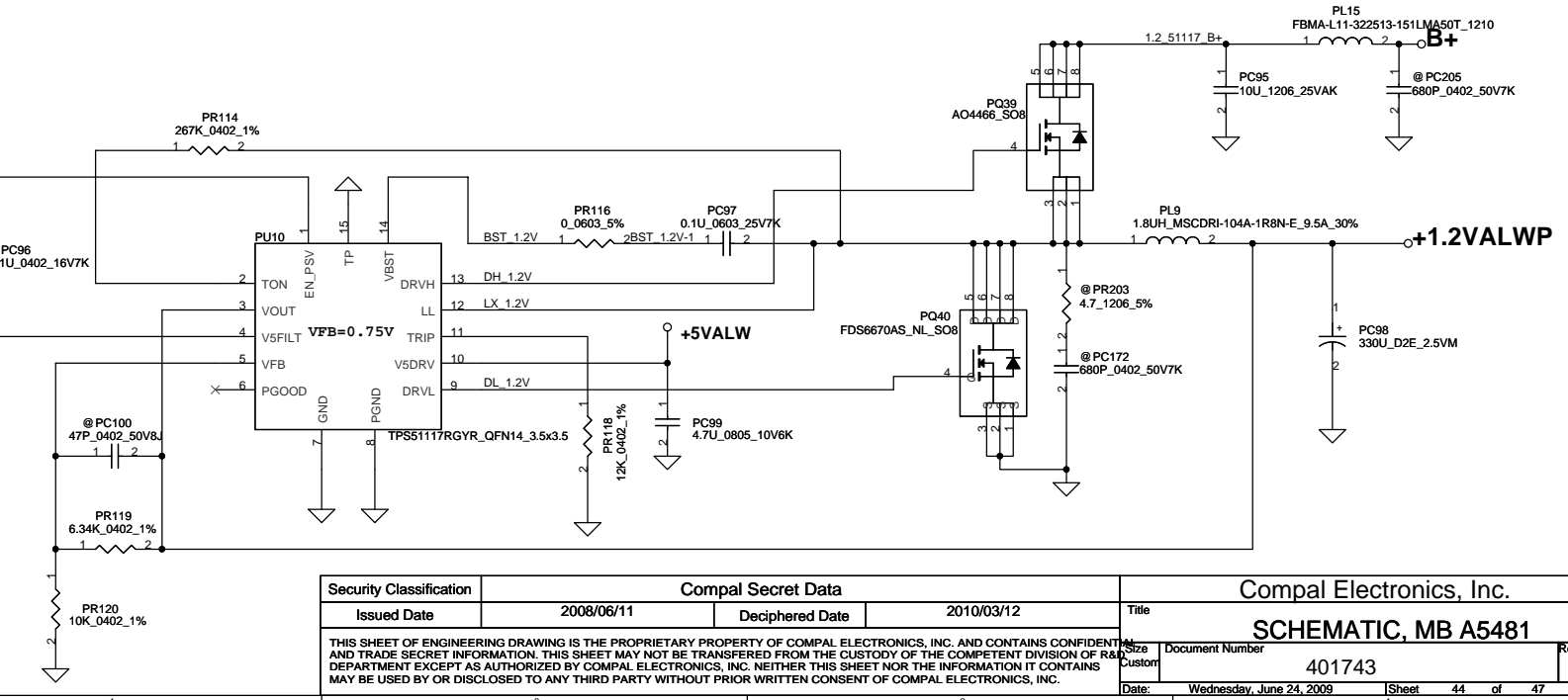

Security Classification		Compal Secret Data		Compal Electronics, Inc.	
Issued Date	2008/06/11	Deciphered Date	2010/03/12	Title	SCHMATIC, MB A5481
THIS SHEET OF ENGINEERING DRAWING IS THE PROPRIETARY PROPERTY OF COMPAL ELECTRONICS, INC. AND CONTAINS CONFIDENTIAL AND TRADE SECRET INFORMATION. THIS SHEET MAY NOT BE TRANSFERRED FROM THE CUSTODY OF THE COMPETENT DIVISION OF R&D DEPARTMENT EXCEPT AS AUTHORIZED BY COMPAL ELECTRONICS, INC. NEITHER THIS SHEET NOR THE INFORMATION IT CONTAINS MAY BE USED BY OR DISCLOSED TO ANY THIRD PARTY WITHOUT PRIOR WRITTEN CONSENT OF COMPAL ELECTRONICS, INC.					
Size	Custom	Document Number	401743	Rev	C
Date:	Wednesday, June 24, 2009	Sheet	44	of	47

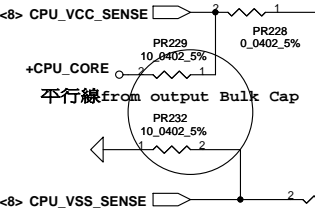
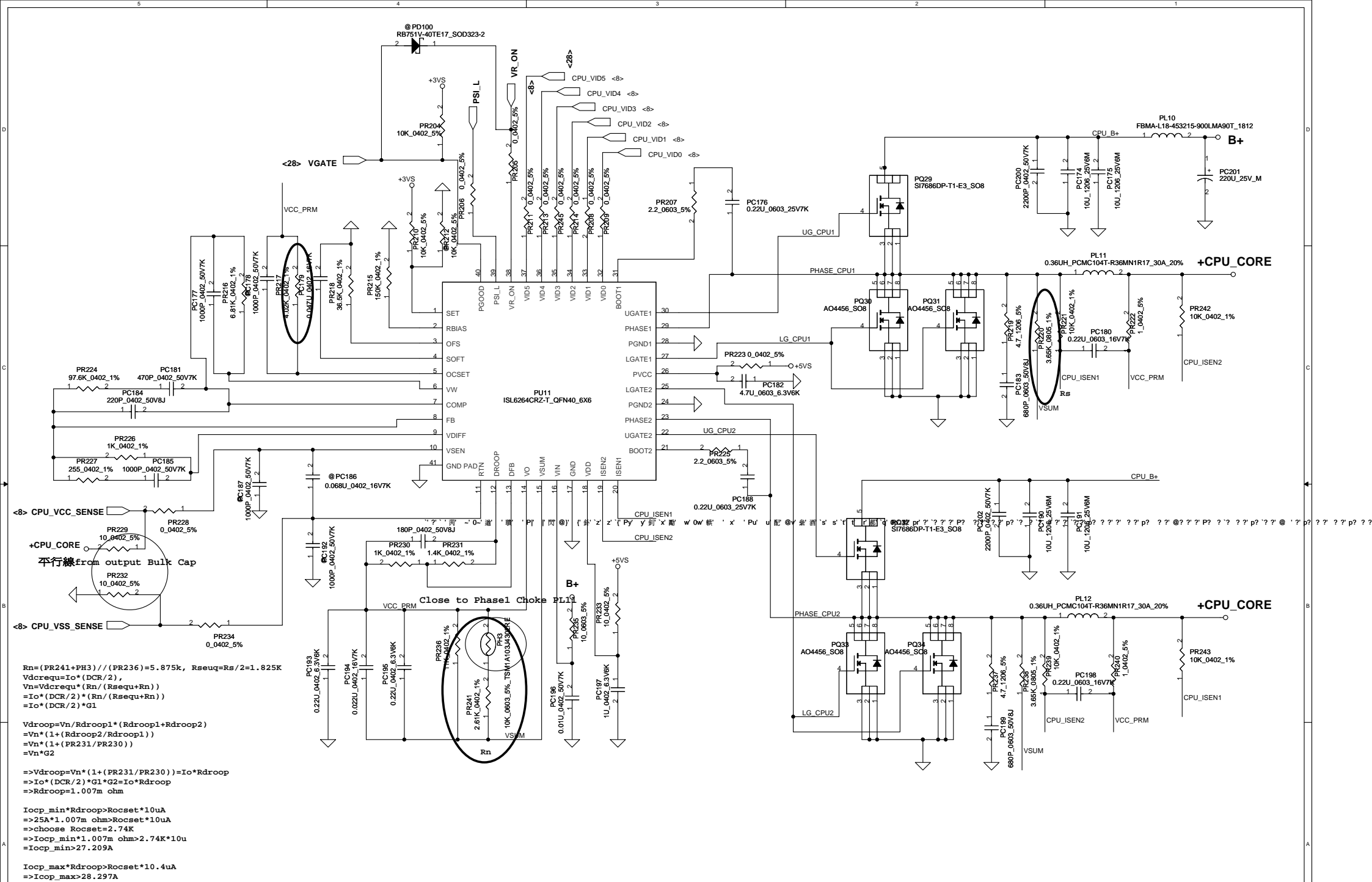

$R_n = (PR241 + PH3) / (PR236) = 5.875k$, $R_{seque} = R_s / 2 = 1.825k$
 $V_{dcreq} = I_o * (DCR / 2)$
 $V_n = V_{dcreq} * (R_n / (R_{seque} + R_n))$
 $I_o = I * (DCR / 2) * (R_n / (R_{seque} + R_n))$
 $= I_o * (DCR / 2) * G1$
 $V_{droop} = V_n / R_{droop1} * (R_{droop1} + R_{droop2})$
 $= V_n * (1 + (R_{droop2} / R_{droop1}))$
 $= V_n * (1 + (PR231 / PR230))$
 $= V_n * G2$
 $=> V_{droop} = V_n * (1 + (PR231 / PR230)) = I_o * R_{droop}$
 $=> I_o = (DCR / 2) * G1 * G2 = I_o * R_{droop}$
 $=> R_{droop} = 1.007m \text{ ohm}$
 $I_{ocp_min} * R_{droop} > R_{ocset} * 10\mu A$
 $=> 25A * 1.007m \text{ ohm} > R_{ocset} * 10\mu A$
 $=> \text{choose } R_{ocset} = 2.74k$
 $=> I_{ocp_min} * 1.007m \text{ ohm} > 2.74k * 10\mu A$
 $=> I_{ocp_min} > 27.209A$
 $I_{ocp_max} * R_{droop} > R_{ocset} * 10.4\mu A$
 $=> I_{ocp_max} > 28.297A$
 $I_{ocp} = -27.209A - 28.297A$

Security Classification	Compal Secret Data		Title	
Issued Date	2008/06/11	Deciphered Date	2010/03/12	Compal Electronics, Inc.
THIS SHEET OF ENGINEERING DRAWING IS THE PROPRIETARY PROPERTY OF COMPAL ELECTRONICS, INC. AND CONTAINS CONFIDENTIAL AND TRADE SECRET INFORMATION. THIS SHEET MAY NOT BE TRANSFERRED FROM THE CUSTODY OF THE COMPETENT DIVISION OF R&D DEPARTMENT EXCEPT AS AUTHORIZED BY COMPAL ELECTRONICS, INC. NEITHER THIS SHEET NOR THE INFORMATION IT CONTAINS MAY BE USED BY OR DISCLOSED TO ANY THIRD PARTY WITHOUT PRIOR WRITTEN CONSENT OF COMPAL ELECTRONICS, INC.				SCHMATIC, MB A5481 Document Number 401743 Rev C
Date:	Wednesday, June 24, 2009	Sheet	45	of 47

Item	Fixed Issue	Reason for change	Rev.	PG#	Modify List	Date	Phase
1	HW required to adjust from 1.14V to 1.12V	HW required to adjust from 1.14V to 1.12V	0.1	42	Change PR271 from SD034300180 (S RES 1/16W 3K +-1% 0402) to SD034324180 (S RES 1/16W 3.24K 0402 1%)	09, 05/07	to PVT
2	Power sequense adjust.	HW required to adjust power sequense.	0.1	42	Add PC208 SE076104K80 (S CER CAP .1U 16V K X7R 0402)	09, 05/07	to PVT
3	Power sequense adjust.	HW required to adjust power sequense.	0.1	42	Change PR247 from SD028000080 (S RES 1/16W 0 +-5% 0402) to SD028130180 (S RES 1/16W 1.3K 0402 5%)	09, 05/07	to PVT
4	NB_COREP working frequency has issue.	Because NB_COREP working frequency will be gitter while system at heavy loading. Change to larger ESR Cap will be solve.	0.1	42	Change PC210 from SGA19331D00 (S POLY C 330U 2.5V M D2 TPE LESR15M H1.8) to SGA00002B00 (S POLY C 330U 6.3V M D2E ESR25M TPE H1.8)	09, 05/07	to PVT
5	BOM error	BOM error	0.1	42	Add PR270 SD28100280(S RES 1/16W 10K 0402 5%)	09, 05/07	to PVT
6	BOM error	BOM error	0.1	42	Change PR103 from SD028470280(S RES 1/16W 47K 0402 5%) to SD028100280(S RES 1/16W 10K 0402 5%)	09, 05/07	to PVT
7							
8							
9							
10							
11							
12							
13							
14							
15							
16							
17							
18							

Security Classification		Compal Secret Data		Compal Electronics, Inc.	
Issued Date	2008/06/11	Deciphered Date	2010/03/12	Title	SCHMATIC, MB A5481
THIS SHEET OF ENGINEERING DRAWING IS THE PROPRIETARY PROPERTY OF COMPAL ELECTRONICS, INC. AND CONTAINS CONFIDENTIAL AND TRADE SECRET INFORMATION. THIS SHEET MAY NOT BE TRANSFERRED FROM THE CUSTODY OF THE COMPETENT DIVISION OF R&D DEPARTMENT EXCEPT AS AUTHORIZED BY COMPAL ELECTRONICS, INC. NEITHER THIS SHEET NOR THE INFORMATION IT CONTAINS MAY BE USED BY OR DISCLOSED TO ANY THIRD PARTY WITHOUT PRIOR WRITTEN CONSENT OF COMPAL ELECTRONICS, INC.				Document Number	401743
				Date:	Wednesday, June 24, 2009
				Sheet	46 of 46

Version change list (P.I.R. List) for HW

Item	Reason for change	Modify List	PG#	Date	Item	Reason for change	Modify List	Rev.	PG#
1	PWR update circuit			4/9	26				
2	BOM change	R118 reserve	P.18	4/9	27				
3	BOM change	Change R178, R179 to 90.9/158 ohm	P.16	4/9	28				
4	BOM change	R30, R39 reserve	P.24	4/9	29				
5	BOM change	Add C30	P.38	4/9	30				
6	BOM change	Add R634, R639	P.28	4/9	31				
7	BOM change	C383 Reserve	P.24	4/9	32				
8		Pop R419	P.20	4/10	33				
9	PWR update circuit			5/15					
10	For Panel flash issue	R1.D2 Reserve, pop R763	P.24	5/18					
11	For Panel flash issue	Add R414 and non-pop	P.24	5/18					
12	Lid_SW intial issue	Add R19	P.28	5/18					
13	HPET timer issue	Change C288,C290 to 33P	P.16	5/18					
14	BOM change	change C276,C279 10P to 27P	P.19	5/19					
15									
16									
17									
18									
19									
20									
21									
22									
23									
24									
25									

Security Classification		Compal Secret Data		Compal Electronics, Inc.	
Issued Date	2005/03/08	Deciphered Date	2010/03/12	Title	
THIS SHEET OF ENGINEERING DRAWING IS THE PROPRIETARY PROPERTY OF COMPAL ELECTRONICS, INC. AND CONTAINS CONFIDENTIAL AND TRADE SECRET INFORMATION. THIS SHEET MAY NOT BE TRANSFERRED FROM THE CUSTODY OF THE COMPETENT DIVISION OF R&D DEPARTMENT EXCEPT AS AUTHORIZED BY COMPAL ELECTRONICS, INC. NEITHER THIS SHEET NOR THE INFORMATION IT CONTAINS MAY BE USED BY OR DISCLOSED TO ANY THIRD PARTY WITHOUT PRIOR WRITTEN CONSENT OF COMPAL ELECTRONICS, INC.				Document Number	Rev
				401743	C
Date: Wednesday, June 24, 2009				Sheet	47 of 47